

34147/B

LOUDON

Encyclopaedia of agriculture, 1839




Nº 2362

22

4157





Digitized by the Internet Archive
in 2018 with funding from
Wellcome Library

<https://archive.org/details/b29304489>

CHAP. IX.

Plantations and Woodlands.

3906. *Without trees*, a landed estate may be very profitable, on account of its mines, waters, and farm lands; but it will be without the noblest characteristic of territorial surface. It may possess the beauty of utility in a high degree, and especially to the owner; but it will not be much admired by the public, nor contribute greatly to the ornament of the country — for what is a landscape without wood? It is not meant, however, that plantations of trees should be made on estates for the sake of ornament; on the contrary, none need ever be made which shall not be at the same time useful, either from the products of the trees individually, or their collective influence on surrounding objects.

3907. *Trees have been planted and cherished in all countries, and from the earliest ages*; but the formation of artificial plantations chiefly with a view to profit appears to have been first practised in Britain, about the end of the sixteenth century, when the insufficiency of the natural forests, which had hitherto supplied civilised society in England with timber and fuel, rendered planting a matter of necessity and profit. In the century succeeding, the improved practice of agriculture created a demand for hedges, and strips for shelter; and the fashion of removing from castles in towns and villages to isolated dwellings surrounded by verdant scenery, led to the extensive employment of trees both as objects of distinction and value. For these combined purposes, planting is now universally practised on most descriptions of territorial surface, for objects principally relating to utility; and, in all parks and grounds surrounding country residences, for the joint purposes of utility and beauty. It has often been suggested, that an agreement might be made between landlord and tenant, under which it would be the tenant's interest to plant trees upon suitable parts of his farm, of little value for other purposes, and to protect them when planted. This would not only promote the interests of both, but add much to the ornament of the country. We cannot but regret that some such plan is not devised and generally adopted.

3908. *Woodlands* are lands covered with wood by nature, and exist more or less on most extensive estates. Sometimes it is found desirable partially or wholly to remove them, and employ the soil in the growth of grass or corn; at other times, their character is changed by art, from coppice or fuel woods, consisting of growths cut down periodically, to trees left to attain maturity for timber.

3909. *In our view of the subject of trees*, we shall include some remarks on improving and managing woodlands, which might have been referred to the two following books; but, for the sake of unity, we prefer treating of every part of the subject together. The ornamental part of planting we consider as wholly belonging to gardening, and indeed the subject of timber trees may be considered as equally one of gardening and of agriculture, being the link by which they are inseparably connected. For a more extended view of the subject, therefore, we refer to our *Encyclopædia of Gardening*, and *Encyclopædia of Plants*: in the former will be found all that relates to the culture of trees collectively; in the latter, all that relates to their botanical character, history, uses, height, native country, and other subjects, with their individual propagation, soil, and culture. We shall here confine ourselves to the soils and situations proper for planting, the trees suitable for particular soils and situations, the operations of forming and managing artificial plantations, and the management of natural woods.

SECT. I. *Soils and Situations which may be most profitably employed in Timber Plantation.*

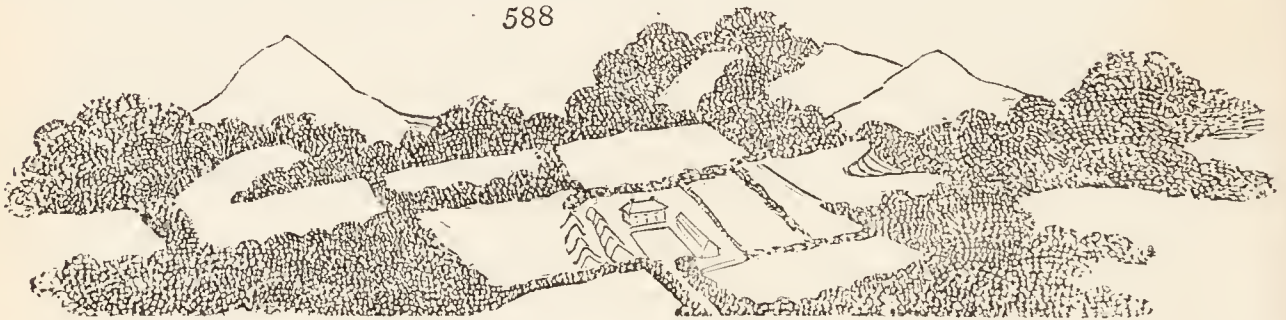
3910. *As a general principle of guidance in planting*, it may be laid down, that lands fit for the purposes of aration should not be covered with wood. Where particular purposes are to be obtained, as shelter, fencing, concealment, or some other object, portions of such lands may require to be wooded; but, in regard to profit, these portions will generally be less productive than if they were kept under grass or corn. The profits of planting do not depend on the absolute quantity of timber produced, but on that quantity relatively to the value of the soil for agricultural purposes. Suppose a piece of ground to let at 20s. per acre, for pasture or aration, to be planted at an expense of only 10l. per acre; then, in order to return the rent, and 5l. per cent. for the money expended, it ought to yield 30s. a year; but as the returns are not yearly, but say at the end of every fifteen years, when the whole may be cut down as a copse, then, the amount of 30s. per annum, at 5l. per cent. compound interest, being 32l. 8s., every fall of copse made at the interval of fifteen years ought to produce that sum per acre clear of all expenses. Hence, with a view to profit from the fall of timber, or copse wood, no situation capable of much agricultural improvement should be planted.

3911. *The fittest situations for planting extensively* are hilly, mountainous, and rocky surfaces; where both climate and surface preclude the hope of ever introducing the plough; and where the shelter afforded by a breadth of wood will improve the adjoining farm lands, and the appearance of the country. Extensive moors and gravelly or sandy soils may often also be more profitably occupied by timber trees than by any other crop, especially near a seaport, collieries, mines, or any other source of local demand.

3912. *On all hilly and irregular surfaces* various situations will be indicated by the lines of fences, roads, the situations of buildings, ponds, streams, &c., where a few trees, or a strip, or mass, or row, may be put in with advantage. We would not, however, advise the uniform mode of planting recommended by Pitt in his *Survey of Staffordshire*, and in *The Code of Agriculture*; that of always having a round clump in the point of intersection of the fences of fields. This we conceive to be one of the most certain modes ever suggested of deforming the surface of a country by planting; the natural character of the surface would be counteracted by it, and neither variety nor grandeur substituted; but a monotony of appearance almost as dull and appalling as a total want of wood.

3913. *Near all buildings* a few trees may in general be introduced; carefully however avoiding gardens and rick-yards, or shading low buildings. In general fewest trees should be planted on the south-east side of cottages; and most on their north-west side; farms and farm buildings in very exposed situations (*fig. 588.*), and also lines of cottages, may be surrounded or planted on the exposed side by considerable masses.

588



3914. *Wherever shelter or shade is required*, plantations are of the first consequence, whether as masses, strips, rows, groups, or scattered trees; all these modes may occasionally be resorted to with advantage even in farm lands.

3915. *Wherever a soil cannot by any ordinary process be rendered fit for corn or grass, and will bear trees*, it may be planted, as the only, or perhaps the best, mode of turning it to profit. There are some tracts of thin stony or gravelly surfaces covered with moss, or very scantily with heath, and a few coarse grasses, which will pay for no improvement whatever, except sowing with the seeds of trees and bushes. These growing up will, after a series of years, form a vegetable soil on the surface. The larch, Scotch pine, birch, and a species of rough moorland willow (*Sàlix*) are the only woody plants fit for such soils. Those who have subjected to the plough old woodland, Sir Henry Steuart remarks, well know how “inconceivably even the poorest soils are meliorated by the droppings of trees, and particularly of the larch, for any considerable length of time, and the rich coat of vegetable mould which is thereby accumulated on the original surface.” It would appear indeed, that on certain surfaces the growth and decay of forests are the means adopted by nature for preparing the soil for the culture of corn; as on certain other soils, a stock of nutritive matter is created by peat moss, or marsh, as on the barest rocks, the rudiments of a soil are formed by the growth and decay of lichens.

3916. *Wherever trees will pay better than any other crop*, they will of course be planted. This does not occur often, but occasionally in the case of willows for baskets and hoops, which are often the most profitable crop on moist deep rich lands; and ash for hoops and crate ware, on drier, but at the same time deep and good, soils.

SECT. II. *Trees suitable for different Soils, Situations, and Climates.*

3917. *Every species of tree will grow in any soil*, provided it be rendered sufficiently dry; but every tree, to bring its timber to the highest degree of perfection, requires to be planted in a particular description of soil, situation, and climate. The effects of soils on trees are very different, according to the kind of tree and the situation. A rich soil and low situation will cause some trees, as the larch and common pine, to grow so fast that their timber will be fit for little else than fuel; and the oak, elm, &c., planted in a very elevated situation, whatever be the nature of the soil, will never attain a timber size. In general, as to soils, it may be observed that such as promote rapid growth, render the timber produced less durable, and the contrary; that such soils as are of the same quality for a considerable depth are best adapted, other circumstances being alike, for ramose-rooted trees, as the oak, chestnut, elm, ash, and most hard-wooded trees; and that such soils as are thin, are only fit for spreading or horizontal-rooted trees, as the pine and fir tribe.

3918. *A natural succession in the kind of tree* has been found to take place where natural forests have been destroyed. Evelyn noticed that, at Wooton, where goodly oaks grew and were cut down by his grandfather 100 years before, beech succeeded, and that, when his brother had extirpated the beech, birch rose up. (*Gard. Mag.* vol. iii. p. 351.) In Dwight's *Travels in New England*, a number of instances are given, in some of which the pine and fir tribe were succeeded by deciduous trees, and in others the reverse. Soulange-Bodin also, and some other French and German writers, have observed the same thing to take place on the continent of Europe, and use the fact as an argument for the introduction of exotic trees to succeed the natives.

3919. *A table of soils and the trees suitable to them*, which may be of some use, is given in *The Agricultural Survey of Kent*. It indicates the trees which grow naturally on a variety of soils and subsoils; and, next, the sorts which yield most profit on such soils.

<i>Surface Soil.</i>	<i>Subsoil.</i>	<i>Common Growth.</i>	<i>Planted Growth.</i>	<i>Uses of.</i>
Heavy and gravelly loams.	Heavy loam with chalk.	Birch, hornbeam, oak, ash, hazel, beech, &c.	Oak, ash, chestnut, willow, lime, walnut.	Timber, hop-poles, cordwood, hurdles, bavins for bakers, and lime-works.
Sandy loams.	Heavy loam.	Ditto.	Elm, beech, Weymouth pine, common spruce.	Ditto.
Flinty strong loam.	Heavy loam.	Ditto.	Willow and chestnut.	Timber, fencing-poles, and as above.
Gravelly and sandy loams.	Gravelly loam.	Ash, beech, oak, hazel, &c.	Chestnut, ash.	Hop-poles, fencing-poles, and all as above.
Gravelly, sandy, and flinty loams.	Heavy, gravelly, flinty loam.	Ash, beech, hornbeam, and oak.	Ash, beech, larch, &c.	Timber, fencing, hop-poles, cordwood for charcoal, bavins, &c.
Flinty, dry, poor gravelly loams.	Chalk at two feet depth with gravelly loam.	Beech, oak, &c.	Beech, larch, &c.	Cordwood, bavins, and hop-poles.
Flinty and gravelly loams.	Chalk 4 feet with deep gravelly loam.	Ash, oak, hazel, &c.	Ash, larch, &c.	Cordwood, hop-poles, bavins, stakes, ethers, &c.
Ditto.	With a few flints, but nearly as above.	Oak, hazel, beech, and ash.	Chestnut, ash, and willow.	Hop-poles, fencing poles, stakes, cordwood, &c.
Lightish black loam.	Dry sandy gravel.	Birch, elm, ash.	Ash, elm, &c.	Various uses in husbandry.
Flinty gravelly loams.	Strong loam with flints.	Oak, ash, beech, &c.	Ash, &c.	Poles, bavins, cordwood, &c.
Chalky, flinty, gravelly loam.	Chalk, with some gravelly loam.	Ditto.	Ditto.	Ditto.
Gravelly loam.	Heavy flinty and poor loam.	Oak, ash, hazel, and beech.	Ash, oak, &c.	Common produce a few poles, cordwood, bavins, &c. plantation many poles, and the above.
Gravelly and chalky loams.	Gravelly loam with chalk.	Oak, ash, &c.	Ash and chestnut.	Poles, cordwood, &c.
Gravelly loam.	Ditto.	Ash, oak, & beech.	Oak, larch.	Ditto.
Ditto.	Gravelly loam and heavy loam.	Ditto.	Scotch pine.	The same.
Sandy gravel.	Gravelly and sandy loam.	Ditto, Scotch pine.	Larch, chestnut, &c.	Poles, stakes, ethers, &c. &c.
Stone, shatter, and gravelly loam.	Strong loam with ragstone.	Oak, hazel, birch, &c.	Birch, oak, &c.	Oaken tillers, small timber poles, &c.
Stone, shatter, and gravelly loam.	Gravelly loam with some stone.	Oak, birch, aspen, hazel, and ash.	Ash, chestnut, and willow.	Fencing-poles, hop-poles, cordwood, &c.
Gravelly loam.	Gravelly loam with some stones.	Oak.	Chestnut.	Hop-poles, fence poles, &c.
Sandy loam.	Gravelly loam.	Birch, oak, hornbeam, &c.	Chestnut, &c.	Fence poles, hop-poles, &c.
Sandy loam and stone shatter.	Gravelly loam with ragstone.	Oak, beech, birch, hazel, ash.	Ditto.	Ditto.
Gravelly loam and stone shatter.	Deep loam, heavy clay and gravel.	Ditto.	Ditto.	Ditto.
Ditto.	Gravelly loam.	Ditto.	Ditto.	Ditto.
Gravelly and sandy loam.	Strong clay and loam.	Oak, and ditto.	Ash, larch, &c.	Poles, fire-wood, &c. as above.
Gravelly loam flinty.	Gravel with clay and some flint.	Scrubby oak, hazel, &c.	Oak, ash.	Timber and ditto.
Wet spongy land.	Moist and boggy earth.	Alder, willow.	Alder, osier, willow, &c.	Hurdles, hop-poles, &c.
Drier ditto.	Ditto more dry.	Poplar.	White poplar, willow.	Hop-poles, &c.
Light sandy loam.	Dry gravelly earth.	Mountain ash, ash.	Scotch pine, silver fir.	Hop-poles.
Light gravelly loam.	With dry gravel.	Ash.	Sycamore.	Timber-turnery, &c.

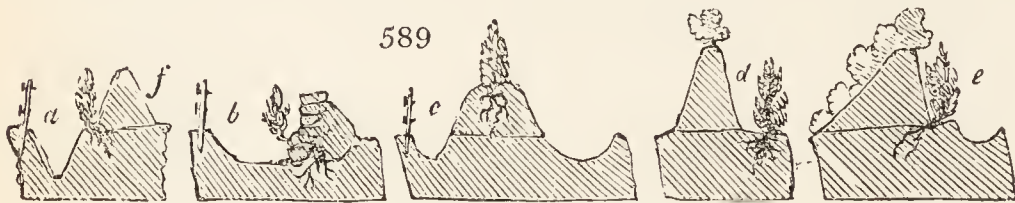
3920. *With respect to climate*, the trees which grow nearest the regions of perpetual snow are the birch, common pine, white beam, larch, mountain ash, and elder. A warmer zone is required for the sycamore and hornbeam; and still more for the beech, ash, elm, and maple. The exotic pines and firs prefer dry sheltered dingles and ravines, not far up the sides of hills; and the oak, chestnut, lime, poplars, tree willows, and a variety of American trees, will not thrive at any great elevation above the sea. The hardiest shore trees are the sycamore, beech, and elder; but on sheltered shores, or such as are little subject to the sea-breeze, pines, firs, and most sorts of trees will thrive.

3921. *The sort of product desired from planting*, as whether shelter, effect, or timber, copse, bark, fuel, &c. and what kinds of each, must be, in most cases, more attended to than the soil, and in many cases even than the situation. The thriving of trees and plants of every kind, indeed, depends much more on the quantity of available soil, and its state in respect to water and climate, than on its constituent principles. Moderately sheltered and on a dry subsoil, it signifies little, as far as growth is concerned, whether the surface strata be a clayey, sandy, or calcareous loam: all the principal trees will thrive nearly equally well in any of these, so circumstanced; but no tree whatever in these or in any soil saturated with water, and in a bleak exposed site. The durability of the timber of different trees, produced under such circumstances, will also be very different. For durability, as already observed, it seems essential that every species of tree should be planted in its natural soil, situation, and climate. For hedge-row timber, those kinds which grow with lofty stems, which draw their nourishment from the subsoil, and do least injury by their shade, are to be preferred. These, according to Blaikie, are oaks, narrow-leaved elm, and black Italian poplar; beech, ash, pines, and firs, he says, are ruinous to fences, and otherwise injurious to farmers. (*On Hedges and Hedgerow Timber*, p. 10.)

SECT. III. *Forming Plantations.*

3922. *The formation of plantations* includes the enclosing, the preparation of the soil, and the mode of planting or sowing.

3923. *The enclosing of plantations* is too essential a part of their formation to require enlarging on. In all those of small extent, as hedges and strips, it is the principal part of the expense; but to plant in these forms, or in any other, without enclosing, would be merely a waste of labour and property. The sole object of fencing being to exclude the domestic quadrupeds, it is obvious, that whatever in the given situation is calculated to effect this at the least expense, the first cost and future repairs or management being taken into consideration, must be the best. Where stones abound on the spot, a wall is the best and cheapest of all fences as such; but, in the great majority of cases, recourse is obliged to be had to a verdant fence of some sort, and generally to one of hawthorn. This being itself a plantation, requires to be defended by some temporary barrier, till it arrives at maturity; and here the remark just made will again apply, that whatever temporary barrier is found cheapest in the given situation will be the best. Hedge fences are in general accompanied by an open drain, which, besides acting in its proper capacity, furnishes at its formation a quantity of soil to increase the nutriment of the hedge plants;



an excavation (*fig. 589. a*), and an elevation (*f*), to aid in the formation of a temporary fence.

A hedge enclosing a plantation requires only to be guarded on the exterior side; and of the various ways in which this is done, the following may be reckoned among the best and most generally applicable: — an open drain and paling, or line of posts and rails; the plants inserted in a facing of stone, backed by the earth of the drain (*b*), an excellent mode, as the plants generally thrive, and almost never require cleaning from weeds; an open drain and paling, and the hedge on the top of the elevation (*c*); no open drain, but, the soil being a loam, the surface-turves formed into a narrow ridge, to serve as a paling, a temporary hedge of furze sown on its summit, and the permanent hedge of thorn or holly within (*d*); and an open drain, but on the inside, the exterior being protected by a steep bank sown with furze (*e*). The first of these modes is the most general, the second the best, and the fourth the cheapest, where timber is not abundant. Separation fences are commonly formed in the first, second, or third manner, but with a paling on both sides. (*See Fences*, Part II. Book IV.)

3924. *In the preparation of the soil for planting*, draining is the first operation. Whatever may be the nature of the soil, if the plants are intended to thrive, the subsoil ought to be rendered dry. Large open drains may be used, where the ground is not to undergo much preparation; but where it is to be fallowed or trenched, under-drains become requisite. It is true they will in time be choaked up by the roots of the trees; but by that period, as no more culture will be required, they may be opened and left open. Many situations, as steep sides of hills and rocky irregular surfaces, do not admit of preparing the soil by comminution previously to planting; but wherever that can be done, either by trenching, digging, or a year's subjection to the plough, it will be found amply to repay

the trouble. This is more especially requisite for strips for shelter, or hedge-rows, as the quick growth of the plants in these cases is a matter of the utmost consequence. The general mode of planting hedges by the side of an open drain renders preparation for them, in many cases, less necessary; but for strips of trees, wherever it is practicable, and there is at the same time no danger of the soil being washed away by rains or thaws, as in some chalky hilly districts, or blown about by the wind, as in some parts of Norfolk and other sandy tracts, preparation by a year's fallow, or by trenching two spits deep, cannot be omitted without real loss, by retarding the attainment of the object desired. Mr. Withers of Norfolk not only prepares poor light land by paring, and burning, and trenching, but even spreads on it marl and farmyard dung, as for a common agricultural crop; and at the same time keeps the surface perfectly free from weeds by hoeing till the young trees have completely covered the ground. The progress that they make under this treatment is so extremely rapid, as apparently to justify, *in an economical point of view*, the extraordinary expenses that attend it. In three years, even oaks and other usually slow-growing forest trees have covered the land, making shoots of three feet in a season, and throwing out roots well qualified, by their number and length, to derive from the subsoil abundant nourishment, in proportion as the surface becomes exhausted. (*Trans. Soc. for Encour. Arts*, vol. xlv.) Cobbett (*The Woodlands*, 8vo. 1825.) recommends trenching the ground two feet deep at the least, keeping the old soil still at the top, unless there is plenty of manure, when, he says, the top soil may be laid in the bottom of the trench. There are instances stated, of promising oak plantations, from acorns dibbed into soil altogether unimproved, and of plantations of Scotch pine raised by merely scattering the seeds, without covering, on a heath or common, and excluding cattle (*General Report of Scotland*, ii. 269.); but these are rare cases, and the time required, and the instances of failure, are not mentioned. The practice is obviously too rude to be recommended as one of art. The best situations for planting, without any other culture but inserting the seeds or plants, are surfaces partially covered with low woody growths, as broom, furze, &c. "The ground which is covered, or rather half covered, with juniper and heath," says Buffon, "is already a wood half made." Gordon, Emmerich, Hayes, Speechly, Marshall, Cruikshank, and others, have shown that the most effectual method of raising oak plantations is by sowing patches of 3 or 4 acorns on dug spots, as far distant from one another as is to be the distance of the trees when half grown. The intermediate spaces, if not covered with furze, broom, or native copse, are to be planted with birch, larch, spruce, or Scotch pine. (See § 3923.)

3925. *A controversy on the subject of the preparation of the soil previously to planting*, has lately arisen between Sir Henry Stuart, Sir Walter Scott, Mr. Withers, Mr. Billington, and others, which it might be deemed improper to pass over here without notice. Scott contends, that preparing the soil accelerates the growth of the tree for a few years only, and, in as far as it has that effect, renders the timber of a less durable quality. Stuart admits the rapidity of the growth of timber on soils which have been prepared, but seems to allow, with Scott, that the timber will be less durable. Withers and Billington assert, that the preparation of the soil accelerates the growth of timber without impairing its durability; and the former has cited some experiments to show that oak, which has grown on good soils and rapidly, has proved stronger than oak which had grown on worse soils slowly. The result of general experience, or what may be called the common sense of gardeners and foresters on this subject, seems to be this:—Preparation of the soil greatly increases the rapidity of the growth of trees, and it has not been found to lessen the strength of the timber produced; on the contrary, oak, ash, willow, and poplar, when freely, or rapidly rather than slowly grown, seem to produce stronger timber, than when slowly and stintedly grown on poor soils. But strength and durability are properties that depend on different qualities of organisation, and it is generally considered that slowly-grown timber is the most durable. We have, ourselves, no doubt of the fact, and more especially in the case of the resinous timbers. We have seen both larch and Scotch pine of a timber size, which had been rapidly grown in rich soil, and which, when cut down, had begun to decay in the heart. We would not, however, on that account cease to prepare the soil for resinous trees, as much as for the other kinds, where practicable; but we would take care to plant resinous trees only on poor soils. We have reason to believe that these opinions on the preparation of the soil for trees, and the durability and strength of timber, are those of the practical men of the present day of greatest science and experience; such, for example, as Sang, Gorrie, Main, Billington, and Cruikshank; and therefore we consider them as more especially entitled to attention in a work like the present.

3926. *Whether extensive plantations should be sown or planted* is a question about which planters are at variance. Miller says, transplanted oaks will never arrive at the size of those raised where they are to remain from the acorn. (*Dict. Quercus*.) Marshal prefers sowing where the ground can be cultivated with the plough. (*Plant. and Rur. Orn.* i. 123.) Evelyn, Emmerich, and Speechly, are of the same opinion; Pontey and Nicof

practise planting, but offer no arguments against sowing where circumstances are suitable. Sang says, "It is an opinion very generally entertained, that planted timber can never, in any case, be equal in durability and value to that which is sown. We certainly feel ourselves inclined to support this opinion, although we readily admit that the matter has not been so fully established, from experiment, as to amount to positive proof. But although we have not met with decided evidence, to enable us to determine on the comparative excellence of timber raised from seeds, without being replanted, over such as has been raised from replanted trees, we are left in no doubt as to the preference, in respect of growth, of those trees which are sown, over such as are planted." (*Plant. Kal.* 43.) He particularly prefers this mode for raising extensive tracts of the Scotch pine and larch (p. 430.), and is decidedly of opinion, "that every kind of forest tree will succeed better by being reared from seeds in the place where it is to grow to maturity, than by being raised in any nursery whatever, and thence transplanted into the forest." (p. 344.) Dr. Yule (*Caled. Hort. Mem.* ii.), in a long paper on trees, strongly recommends sowing where the trees are finally to remain. "It is," says he, "a well ascertained fact, that seedlings allowed to remain in their original station, will, in a few seasons, far overtop the common nursed plants several years older."

3927. *The opinion of Dr. Yule* seems to be founded on the idea that the tap-root is of great importance to grown up trees, and that when this is once cut off by transplanting, the plant has not a power of renewing it. That the tap-root is of the utmost consequence for the first three or four years, perhaps for a longer period, is obvious, from the economy of nature at that age of the plant; but that it can be of no great consequence to full-grown trees, appears highly probable from the fact, that when such trees are cut down, the tap-root is seldom to be distinguished from the others. The opinion that young plants have not the power of renewing their tap-root, will, we believe, be found inconsistent with fact; and we may appeal to nurserymen, who raise the oak and horse-chestnut from seed. It is customary when these are sown in drills, to cut off their tap-roots without removing the plants at the end of the second year's growth, and when, at the end of the third or fourth year, they are taken up, they will be found to have acquired other tap-roots, not indeed so strong as the first would have been had they remained, but sufficient to establish the fact of the power of renewal. We may also refer to the experiment recorded by Forsyth, which at once proves that trees have a power of renewing their tap-roots, and the great advantages from cutting down trees after two or three years' planting. Forsyth "transplanted a bed of oak-plants, cutting the tap-roots near to some of the side-roots or fibres springing from them. In the second year after, he headed one half of the plants down, and left the other half to nature. In the first season, those headed down made shoots six feet long and upwards, and completely covered the head of the old stem, leaving only a faint cicatrix, and produced new tap-roots upwards of two feet and a half long. That half of the plants that were not headed, were not one fourth the size of the others. One of the former is now eighteen feet high, and fifteen inches in circumference, at six inches from the ground: one of the largest of the latter measures only five feet and a half in height, and three inches and three quarters in circumference, at six inches from the ground." (*Tr. on Fruit Trees*, 4to. edit. 144.) The pine and fir tribes receive most check by transplanting; and when removed at the age of four or five years, they seldom arrive at trees afterwards; those we should, on most occasions, prefer to sow, especially upon mountainous tracts. But for all trees which stole, and in tolerable soils and situations, planting strong plants, and cutting them down two or three years afterwards, will, we think, all circumstances considered, be found preferable to sowing. If we made an exception, it would be for the oak in poor soils, which we would raise from the acorn in Cruikshank's manner. Sir Henry Steuart (*Planter's Guide*, 2d edit. p. 423.) concurs in this opinion, with respect to deciduous trees, and considers that as the pine and fir tribes receive "the greatest check from transplanting; and as, when planted at four and five years old, they do not readily grow to timber, it is clear that they should always be sowed, or at least planted, very young, in high and cold regions."

3928. *On the subject of disposing the plants in plantations, there are different opinions*; some advising rows, others quincunx, but the greater number planting irregularly. According to Marshal, "the preference to be given to the row, or the random culture, rests in some measure upon the nature and situation of the land to be stocked with plants. Against steep hangs, where the plough cannot be conveniently used in cleaning and cultivating the interspaces, during the infancy of the wood, either method may be adopted; and if plants are to be put in, the quincunx manner will be found preferable to any. But in more level situations, we cannot allow any liberty of choice: the drill or row manner is undoubtedly the most eligible." (*Plant. and Rur. Orn.* p. 123.) Pontey considers it of much less consequence than most people imagine, whether trees are planted regularly or irregularly, as in either case the whole of the soil will be occupied by the roots and the surface by the shoots. Sang and Nicol only plant in rows where culture with the horse-hoe is to be adopted. In sowing for woods and copses, the former places the patches six feet asunder and in the quincunx order. "It has been demonstrated (*Farmer's Mag.* vol. vii. p. 409.), that the closest order in which it is possible to place a number of points upon a plain surface, not nearer than a given distance from each other, is in the angles of hexagons with a plant in the centre of each hexagon." Hence it is argued, that this order of trees is the most economical; as the same quantity of ground will contain a greater quantity of trees, by 15 per cent. when planted in this form than in any other. (*Gen. Rep.* ii. 287.) It is almost needless to observe, that hedge plants should be placed at regular distances in the lines, and also the trees, when those are introduced in hedges. Osier plantations, and all such as like them require the soil to be dug every year, or every two years, during their existence, should also be planted in regular rows.

3929. *The distances at which the plants are placed* must depend on different circumstances, but chiefly on the situation and soil.

3930. *Planting thick, according to Nicol*, is the safer side to err on, because a number of plants will fail, and the superfluous ones can be easily removed by thinning. For bleak situations, he observes, from thirty to forty inches is a good medium, varying the distance according to circumstances. For less exposed situations, and where the soil is above six inches in depth, he recommends a distance of from four to five feet. For belts, clumps, and strips of a diameter of about one hundred feet; the margin to be planted about the distance of two feet, and the interior at three feet. In sheltered situations of a deep good soil, he recommends a distance of six feet and no more. (*Pract. Plant.*)

3931. *According to Sang*, "the distances at which hard-timber trees ought to be planted are from six to ten feet, according to the quality of the soil, and the exposed or sheltered situation. When the first four oaks are planted, supposing them at right angles, and at nine feet apart, the interstices will fall to be filled up with five nurses, the whole standing at four feet and a half asunder. When sixteen oaks are planted, there will necessarily be thirty-three nurses planted; and when thirty-six oaks are planted, eighty-five nurses; but when a hundred principal trees are planted in this manner, in a square of ten on the side, there will be two hundred and sixty-one nurse-plants required. The English acre would require five hundred and thirty-six oaks, and one thousand six hundred and ten nurses." (*Plant. Kal.* 163.) Pontey says, "in general cases, a distance of four feet is certainly close enough; as at that space the trees may all remain till they become saleable as rails, spars," &c.

3932. *The number of plants which may be planted on a statute acre = 160 rods, or poles, = 4840 yards = 43560 feet, is as follows: —*

Feet apart.	No. of Plants.	Feet apart.	No. of Plants.	Feet apart.	No. of Plants.
1	43,560	6	1,210	15	193
1½	19,360	7	889	16	170
2	10,890	8	680	17	150
2½	6,969	9	537	18	134
3	4,840	10	435	19	120
3½	3,556	11	360	20	108
4	2,722	12	302	25	69
4½	2,151	13	257	30	48
5	1,742	14	222		

3933. *The size of the plants* depends jointly on the site and the kind of tree; it is universally allowed that none of the resinous tribe succeed well when removed at more than two years' growth; but if the soil is of tolerable quality, prepared by digging or summer pitting, and the site not bleak, plants of such hard woods as stole may be used whose stems are an inch or more in diameter.

3934. *Nicol* is of opinion, "That, generally, trees three, or at most four, years old from the seed, and which are from twelve to twenty-four inches high, will, in any situation or soil, outgrow those of any size under eight or ten feet, within the seventh year." (*Pract. Plant.* 130.)

3935. *Sang* observes, "the size of plants for exclusive plantations must, in some measure, depend on their kinds; but it may be said, generally, that the plants being transplanted, they should be from a foot to eighteen inches in height, stiff in the stem and well rooted. Plants for this purpose should seldom be more than three years from the seed; indeed never, if they have been raised in good soil. Many of them may be sufficiently large at two years from the seed; and, if so, are to be preferred to those of a greater age, as they will consequently be more vigorous and healthy. The larch, if properly treated, will be very fit for planting out at two years of age. A healthy seedling being removed from the seed-bed at the end of the first year, into good ground, will, by the end of the second, be a fitter plant for the forest, than one nursed a second year. The next best plant for the purpose is that which has stood two years in the seed-bed, and has been transplanted for one season. This is supposing it to have risen a weakly plant; for, if the larch rise strong from the seed the first season, it should never stand a second in the seed-bed. The ash, the elm, and the sycamore, one year from the seed, nursed in good soil for a second season, will often prove sufficiently strong plants. If they be weakly, they may stand two years in the seed-bed; and then, being nursed one season in good soil, will be very fit for planting out in the forest. The oak, the beech, and the chestnut, if raised in rich soil, and well furnished with roots at the end of the first year, and having been nursed in rows for two years, will be very fit to be planted out: but if they be allowed to stand two years in the seed-bed, and be planted one year in good ground, they will be still better, and the roots will be found well feathered with fine small fibres. The silver fir and common spruce should stand two years in the seed-bed. If transplanted into very good soil, they may be fit for being planted out at the end of the first year; but, more generally, they require two years in the lines. The Scots pine should also stand for two years in the seed-bed, and should be nursed in good ground for one year; at the end of which they will be much fitter for being planted, than if they were allowed to stand a second year in the lines. They are very generally taken at once from the seed-bed; and, in land bare of heath or herbage, they succeed pretty well; nevertheless, we would prefer them one year nursed. The above are the hardy and most useful forest trees; and from the observations made, whatever respects the age or size of other kinds may easily be inferred." (*Plant. Kal.* 158.)

3936. *According to Pontey*, "the best general rule is, to proportion the size of the plants to the goodness of the soil; the best of the latter requiring the largest of the former. Still, on bleak exposures, this rule will not hold good, as there the plants should never be large, for otherwise the greater part would fail from the circumstance of wind-waving, and, of those that succeeded, few, if any, would make much progress for several years; pines and firs of a foot, and deciduous trees of eighteen inches, are large enough for such places. As in extensive planting, soils which are good and well sheltered but seldom occur, the most useful sizes of plants, for general purposes, will be pines and firs of a foot, and deciduous trees of eighteen inches, both transplanted. None but good-rooted plants will succeed on a bad soil, while on a good one, sheltered, none but very bad-rooted plants will fail. A large plant never has so good a root, in proportion to its size, as a small one; and hence we see the propriety of using such on good soils only. Small plants lose but few of their roots in removal; therefore, though planted in very moderate-sized holes of pulverised earth, they soon find the means of making roots, in proportion to their heads. It should never be forgotten, that, in being removed, a plant of two feet loses a greater proportion of its roots than a tree of one, and one of three feet a greater proportion than one of two, and so on, in proportion to its former strength and height; and thus, the larger the plants, so much greater is the degree of languor or weakness into which they are thrown by the operation of transplanting." (*Prof. Plant.* 161.)

3937. *The seasons for planting* are autumn and spring: the former, when the soil and situation are moderately good, and the plants large; and the latter, for bleak situations. Necessity, however, is more frequently the guide here than choice, and in extensive designs the operation is generally performed in all moderately dry open weather from October to April inclusive. "In an extensive plantation," *Sang* observes, "it will hardly happen but there will be a variety of soil, some parts moist and heavy, and others dry and light. The lightest parts may be planted in December or January; and the

more moist, or damp parts, in February or March. It must be observed, however, that if the ground be not in a proper case for planting, the operation had better be delayed. The plants will be injured, either by being committed to the ground when it is in a sour and wet, or in a dry parched, state. At a time when the soil is neither wet nor dry, the operation of planting is most successfully performed. The mould does not then adhere to the spade, nor does it run in; it divides well, and is made to intermingle with the fibres of the plants with little trouble; and in treading and setting the plant upright, the soil is not worked into mortar, which it necessarily must be, if in a wet state, evidently to the great detriment of the plants. It is therefore improper to plant on a retentive soil in the time of rain, or even perhaps for some days afterwards, or after a fall of snow, until it has for some days disappeared. Whereas, in a dry absorbent soil, it may be proper to plant in the time of gentle showers, immediately after heavy rains, or as soon as the snow is dissolved." (*Plant. Kal.* 157.)

3938. *Pontey* is a decided advocate for autumn preparation of the soil, and spring planting. "Autumn planting," he says, "is advisable only in few cases, while spring planting may properly apply to all."

3939. *According to Sang*, the proper time for planting the pine and fir tribes, and all evergreens, is April, or even the first fortnight in May. "Attention should be paid, that no greater number of plants be lifted from the nursery than can be conveniently planted on the same day. Damp weather is the best. When very dry, and the plants rise destitute of earth at their roots, their roots should be dipped in mud (puddle) so as to be coated over by it. In all cases, care should be taken not to shake off any adhering earth from plants at the time of planting." (*Plant. Kal.* 341.)

3940. *A puddle for trees* is made by mixing water with any soil rather tenacious, so intimately as to form a complete puddle, so thick that when the plants are dipped into it, enough may remain upon the roots to cover them. The process of puddling is certainly simple, and its expense too trifling to deserve notice: its effects, however, in retaining, if not attracting, moisture are such that, by means of it, late planting is rendered abundantly more safe than it otherwise would be. It is an old invention, and hence it is truly astonishing that it is not more frequently practised. If people were to adopt it generally in spring planting, *Pontey* believes the prejudice in favour of autumn practice would soon be done away. (*Prof. Plant.* 167.)

3941. *Cobbett* prefers spring planting. "It is a great error," he says, "to suppose that you gain time by autumnal or winter planting. You do, indeed, see the buds come out a little more early in the spring; but it is the effect at the end, and not at the beginning, of the summer, at which you ought to look. If you plant in the autumn or winter, the plants get *blown about* for several months, and, in very wet weather, their stems work a sort of *hole* round themselves; and thus the root itself is shaken; and if left thus, they will, by March, be generally leaning on one side, with the hole open on the other side; and when the harsh winds of March come upon the long-time battered ground, it will present a surface nearly as hard as a road. In such a case, the ground ought to be dug or spaded up between the trees in March or in April; for nothing can thrive well in ground thus baked, however good the ground may be in its nature." (*The Woodlands*, 44.)

3942. *Pruning previously to planting*. If the plants have been brought from a distance, and the fibrous roots are dried up, they should all be cut off, because, like the leaves of a tree which has been taken up in the growing state and become withered, they have lost their vitality. The larger fibres, which are only dead at the points, should be shortened. The tap-root, also, should be shortened, perhaps in most cases two thirds of its length. *Cobbett* observes, and with truth, as far as our experience goes, that if the longest tap-roots "were put into the ground at full length with an iron bar, they would be sure to die all the way nearly up to the top." (*Woodlands*, 68.) Many trees, however, have no tap-roots, and these only require attention to the fibres. When the plants are newly taken up from the seed-bed, or nursery lines, they may be planted without cutting off the fibres; because these will retain their vitality uninjured.

3943. *The operation of inserting the plants* in the soil is performed in various ways; the most general mode, and that recommended by *Marshal* and *Nicol*, is pitting; in which two persons are employed, one to operate on the soil with the spade, and the other to insert the plant and hold it till the earth is put round it, and then press down the soil with the foot. Where the plants are three feet high or upwards, this is the best mode; but for smaller plants modes have been adopted in which one person performs the whole operation. This method of planting by pitting is what *Withers* calls the Scotch system, but which *Sir Henry Steuart* has shown (*Planter's Guide*, 2d edit. p. 468.) is not peculiar to Scotland, but is common in every country where trees are cultivated.

3944. *Sang* describes five kinds of manual operation employed by him in planting, and in part in sowing trees: by pitting; by slitting simply, or by cross or T slitting; by the diamond dibber; by the planting-mattock; and by the planter or ground adze. In filling an area with plants, he first plants those intended as the final trees, and afterwards the nurses; or one set of operators plant the former, while another follow with the latter, unless the time for removing the nurses, as in the case of evergreen pines and firs, should be later than that for planting the principals. "The plants, if brought from a distance, should be *shoughed*, i. e. *earthed in*; or they may be supplied daily from the nursery, as circumstances direct. All the people employed ought to be provided with thick aprons, in which to lap up the plants, the spadesmen, as well as the boys or girls; the latter being supplied by the former as occasion may require. All of them should regularly fill their aprons at one time, to prevent any of the plants being too long retained in any of the planters' aprons. One man cannot possibly set a plant so well with the spade, unless in the case of *laying*, as two people can; nor, supposing him to do it as well, can he plant half as many in the same space of time as two can. A boy ten years of age is equal, as a holder, to the best man on the field, and can be generally had for less than half the money. Hence this method is not only the best, but the least expensive." (*Plant. Kal.* 167.)

3945. *By pitting.* "The pit having been dug for several months, the surface will therefore be encrusted by the rains, or probably covered with weeds. The man first strikes the spade downwards to the bottom, two or three times, in order to loosen the soil; then poaches it as if mixing mortar for the builder; he next lifts out a spadeful of the earth, or, if necessary, two spadefuls, so as to make room for all the fibres, without their being anywise crowded together; he then chops the rotten turf remaining in the bottom, and levels the whole. The boy now places the plant perfectly upright, an inch deeper than when it stood in the nursery, and holds it firm in that position. The man *trindles* in the mould gently; the boy gently moves the plant, not from side to side, but upwards and downwards, until the fibres be covered. The man then fills in all the remaining mould; and immediately proceeds to chop and poach the next pit, leaving the boy to set the plant upright, and to tread the mould about it. This in stiff wet soil he does lightly; but in sandy or gravelly soil he continues to tread until the soil no longer retains the impression of his foot. The man has by this time got the pit ready for the next plant, the boy is also ready with it in his hand, and in this manner the operation goes on. On very steep *hangs* which have been pitted, the following rule ought to be observed in planting: — To place the plant in the angle formed by the acclivity and surface of the pit; and in finishing, to raise the outer margin of the pit highest, whereby the plant will be made to stand as if on level ground, and the moisture be retained in the hollow of the angle, evidently to its advantage." (*Plant. Kal.* 167.)

3946. *Sir Henry Stewart* states that the pitting system, as already practised by most nations, though by some ignorantly and erroneously designated the Scotch method, if duly regulated by science, must be the best method for the planting of waste lands, or, in general, for large designs of wood, where the quality of timber is the main object; although particular spots, in all extensive woodlands, might be advantageously trenched and manured under peculiar circumstances. (*Planter's Guide*, 2d edit. p. 479.)

3947. *The slit method*, either simply or by the T method, is not recommended by Sang; but necessity may justify its adoption occasionally. "We would not recommend planting by the slit, unless where there is no more soil than is absolutely occupied by the fibres of the herbage which grows on the place. Except on turf, it cannot be performed; nor should it be practised, if the turf be found three or four inches thick. By pitting in summer, turf is capable of being converted into a proper mould in the space of a few months; and the expense of pitting, especially in small plantations, can never counterbalance the risk of success in the eyes of an ardent planter. The most proper time to perform the operation of slitting in the plants is when the surface is in a moist state. On all steep the plant should be placed towards the declivity, that the moisture may fall to its roots; that is to say, in planting, the spadesman should stand highest, and the boy lowest on the bank, by which arrangement the plant will be inserted at the lower angle of the slit." (*Plant. Kal.* 170.)

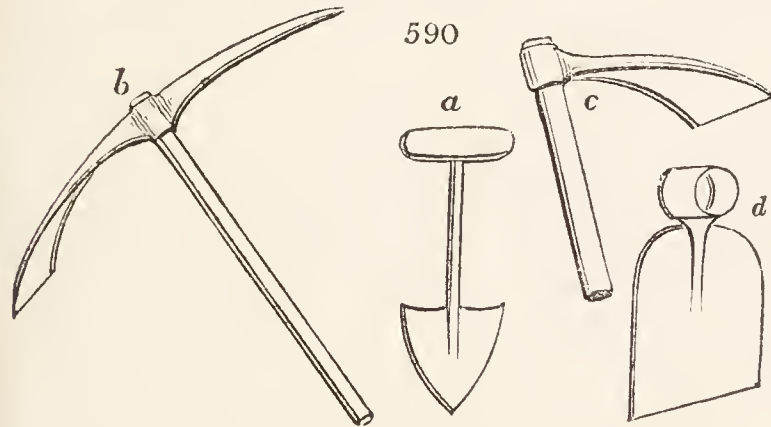
3948. *Planting with the diamond dibber*, he says, "is the cheapest and most expeditious planting of any we yet know, in cases where the soil is a sand or gravel, and the surface bare of herbage. The plate of the dibber (*fig. 590. a*) is made of good steel, and is four inches and a half broad where the iron handle is welded to it; each of the other two sides of the triangle is five inches long; the thickness of the plate is one fifth part of an inch, made thinner from the middle to the sides, till the edges become sharp. The length of the iron handle is seven inches, and so strong as not to bend in working, which will require six eighths of an inch square. The iron handle is furnished with a turned hilt, like the handle of a large gimlet, both in its form and manner of being fixed on. The planter is furnished with a planting-bag, tied round his waist, in which he carries the plants. A stroke is given with the dibber, a little aslant, the point lying inwards; the handle of the dibber is then drawn towards the person, while its plate remains within the ground: by this means a vacuity is formed between the back of the dibber and the ground, into which the planter, with his other hand, introduces the roots of the seedling plants, being careful to put them fully to the bottom of the opening: he then pulls out the dibber, so as not to displace them, and gives the eased turf a smart stroke with the heel; and thus is the plant completely firned. The greatest error the planter with this instrument can run into, is the imperfect introduction of the roots. Green or unpractised hands are apt to double the roots, or sometimes to lay them across the opening, instead of putting them straight down, as above directed. A careful man, however, will become, if not a speedy, at least a good planter in one day; and it is of more importance that he be sure than quick. A careless or slovenly person should never be allowed to handle a dibber of this kind."

3949. *Planting with the planting-mattock* (*fig. 590. b*) is resorted to in rocky or other spots where pitting is impracticable. "The helve or handle is three feet six inches long; the mouth is five inches broad, and is made sharp; the length from it to the eye, or helve, is sixteen inches; and it is used to pare off the sward, heath, or other brush that may happen to be in the way, previously to easing the soil with the other end. The small end tapers from the eye, and terminates in a point, and is seventeen inches long." By this instrument the surface is skimmed off "for six or eight inches in diameter, and with the pick-end dug down six or eight inches deep, bringing up any loose stones to the surface; by which means a place will be prepared for the reception of the plant, little inferior to a pit. This instrument

may be used in many cases, when the plants to be planted are of small size, such as one-year larch seedlings, one year nursed; or two-year Scots pines, one year nursed; and the expense is much less than by the spade." (*Plant. Kal.* 385.)

3950. *Planting with the forest-planter or ground adze* (*fig. 590. c*). "The helve is sixteen inches long, the mouth is four inches and a half broad, and the length of the head is fourteen inches. The instrument is used in planting hilly ground, previously prepared by the hand-mattock. The person who performs the work carries the plants in a close apron; digs out the earth sufficiently to hold the roots of the plant; and sets and firms it without help from another: it is only useful when small plants are used, and in hilly or rocky situations." (*Plant. Kal.* pref. xxiv.)

3951. *Pontey* prefers planting by pitting, in general cases, the holes being made during the preceding summer or winter, sufficiently large, but not so deep into a retentive subsoil as to render them a receptacle for water. When the plants have been brought from a distance, he strongly recommends puddling them previously to planting; if they seem very much dried, it would be still better to lay them in the ground for eight or ten days, giving them a good soaking of water every second or third day, in order to restore their vegetable powers; for it well deserves notice, that a degree of moisture in soil sufficient to support a plant recently or immediately taken from the nursery, would, in the case of dry ones, prove so far insufficient, that most of them would die in it. The

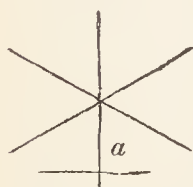


puddling here recommended may also be of great service in all cases of late planting where small plants are used: Pontey's method is (after puddling) to tie them in bundles of two or three hundreds each; and thus send them, by a cart-load at once, to their destination; where, being set upright close to each other, and a little straw carefully applied to their outsides, such bundles may remain without damage in a sheltered situation for any reasonable time necessary to plant them. Where loose soil happens to be convenient, that should be substituted in the place of straw.

3952. *Pontey's methods of planting* are in general the same as those of Sang: he uses a mattock and planter of similar shape; and also a two or three pronged instrument, which we have elsewhere denominated the *planter's hack*. (*Encyc. of Gard.* § 1305.) "This instrument," he says, "has been introduced of late years as an improvement on the mattock and planter, being better adapted to soils full of roots, stones, &c.; it is likewise easier to work, as it penetrates to an equal depth with a stroke less violent than the former: it is also less subject to be clogged up by a wet or tenacious soil. The length of the prongs should be about eight inches, and the distances between them, when with three prongs, one and a half, and with two prongs, about two inches: the two-pronged hack should be made somewhat stronger than the other, it being chiefly intended for very stony lands, or where the soil wants breaking, in order to separate it from the herbage, &c. These tools are chiefly applicable to plants of any size up to about two feet, or such as are generally used for great designs, and they are used as substitutes for the spade, in the following manner:—The planter being provided with a basket holding the plants required (the holes being supposed prepared, and the earth left in them), he takes a tree in one hand, and the tool in the other, which he strikes into the hole, and then pulls the earth towards him, so as to make a hole large enough to hold all its roots; he then puts in the plant with the other, and pushes the earth to its roots with the back of the planter; after which, he fixes the plant, and levels the soil at the same instant with his foot, so that the operation is performed by one person, with a degree of neatness and expedition which no one can attain to who uses the spade. It is known to all planters, that but few labourers ever learn to plant well and expeditiously in the common method, without an assistant; this method, however, requires neither help nor dexterity, as any labourer of common sagacity, or boy of fifteen, or even a woman, may learn to perform it well in less than half an hour. The facility with which these tools will break clods, clear the holes of stones, or separate the soil from herbage, the roots of heath, &c. (the former being previously mellowed by the frost), may be easily imagined." (*Prof. Plant.* 173.) The adoption of a small mattock for inserting plants, we recollect to have seen recommended in a tract on planting in the Highlands, by M'Laurin, a nurseryman, published at Edinburgh upwards of twenty years ago.

3953. *An expeditious mode of slit-planting* is described in the *General Report of Scotland*, as having been practised for many years on the duke of Montrose's estate. It is as follows: "The operator, with his spade, makes three cuts, twelve or fifteen inches long, crossing each other in the centre, at an angle of sixty degrees, the whole

591



having the form of a star. (*fig.* 591.) He inserts his spade across one of the rays (*a*), a few inches from the centre, and on the side next himself; then bending the handle towards himself, and almost to the ground, the earth opening in fissures from the centre in the direction of the cuts which had been made, he, at the same instant, inserts his plant at the point where the spade intersected the ray (*a*), pushing it forward to the centre, and assisting the roots in rambling through the fissures. He then lets down the earth by removing his spade, having pressed it into a compact state with his heel; the operation is finished by adding a little earth, with the grass side down, completely covering the fissures, for the purpose of retaining the moisture at the root and likewise as a top-dressing, which greatly encourages the plant to push fresh roots between the swards." (*Vol.* ii. p. 283.)

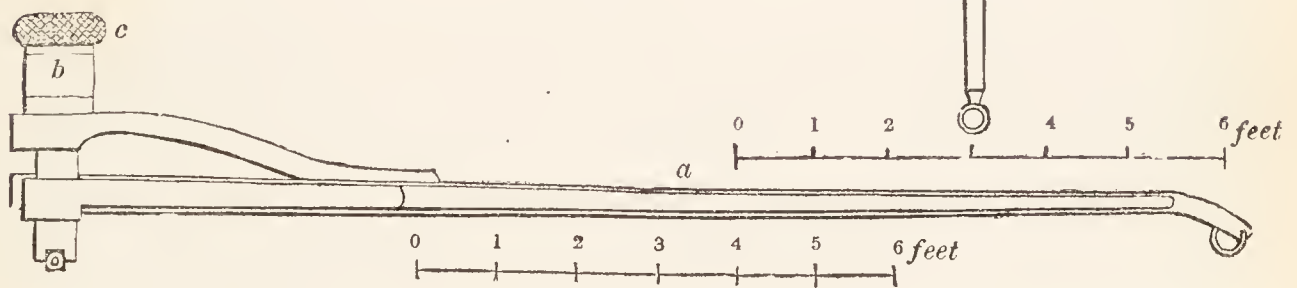
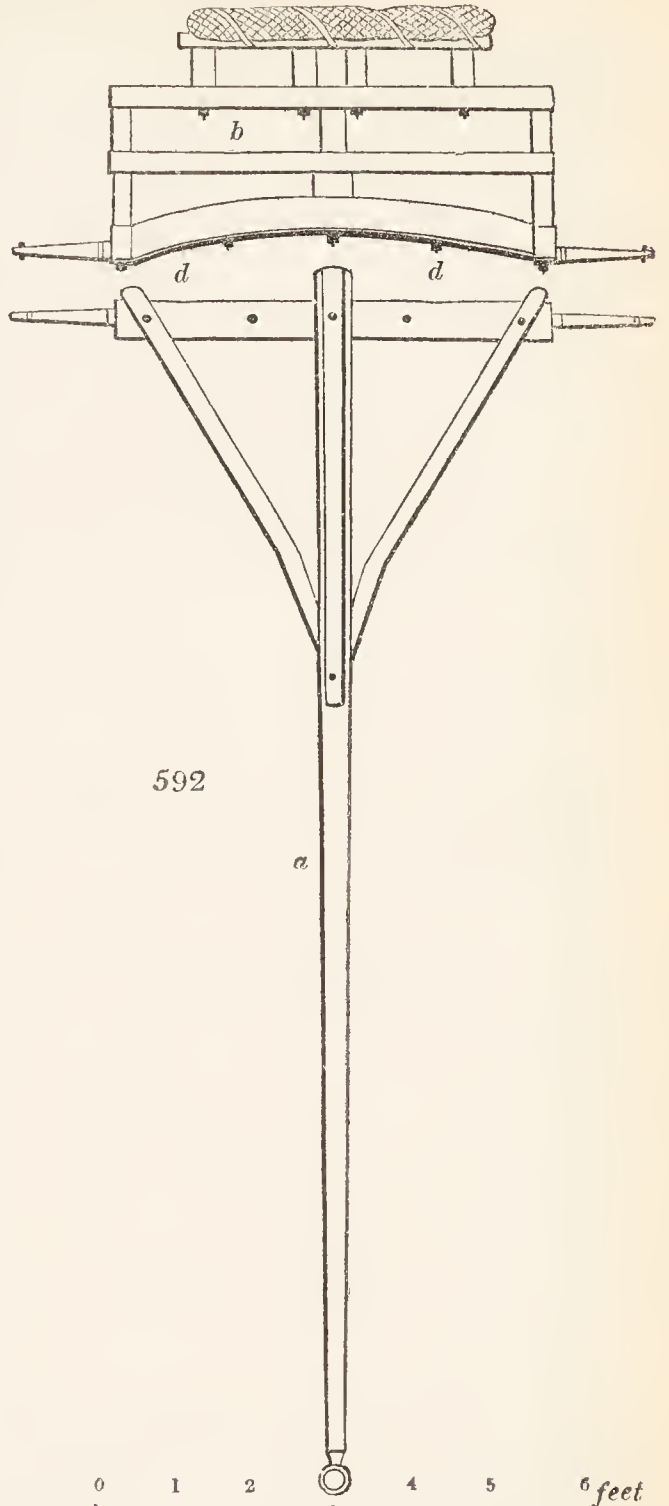
3954. *The transplantation of large trees* is a subject more properly belonging to landscape-gardening than to agriculture; but it may not be improper shortly to notice the principles of the practice in this place. As the stability of a large tree depends in a great measure on its ramose roots extending themselves on every side, as a base to the superstructure, so, in preparing the tree for removal, these roots should be cut at as great a distance from the stem as can conveniently be accomplished. As the nourishment drawn up by a tree depends on the number of its fibrous roots, it is desirable, a year or two before removal, to concentrate these fibres, by limiting their production to such ramose roots as can be removed with the tree. Cut a circular trench, therefore, round the tree to be removed, at a greater or less distance, according to the size of the tree, and the exposure in which it is to be planted. Remove the earth from this trench, and also a good part of that which covers the roots which remain between the trench and the trunk. Substitute well pulverised rich soil; or mix the better part of what was taken out of the trench and off the surface with rich soil; replace it, and press the

whole firmly down. Let the tree remain two years, or three if very large, and then remove it, and carefully plant it where it is finally to remain.

3955. *Sir Henry Stuart*, who has had much experience in removing large trees, and who thinks that he has discovered a new theory or principle for doing so, recommends that no branches should be pruned from the head; and that to prevent the tree from being blown over by the wind, its position relatively to the prevailing wind of the locality should be reversed. The principle of not reducing the head in the same proportion as the roots may be reduced, was hinted at by Miller, but has been first systematically defended by Sir Henry Stuart. Experienced planters agree, that nothing ought to be cut from the head of a beech tree when it is removed; but they do not seem willing to concede to Sir Henry's theory, so far as it respects most other ramose trees. We are inclined to think that he may be right with respect to resinous trees, the beech, and perhaps one or two others; but that, as a general principle, whether in young trees or old, the top must be lightened more or less in proportion to the roots. When the tree has made a stock of fresh roots, and become firmly established in the soil, if an extraordinary exertion in its growth be then wanted, it may either be cut in or pruned severely, or cut down to the ground; and in either case, if it be a tree that stools, it will throw out vigorous shoots.

3956. *The principle of reversing the position of the tree relatively to the wind*, appears to be good; since, the broader the base of the head of the tree relatively to its height, the more obliquely will it receive the impulse of the wind. Those trees are fittest for being transplanted, which have grown in free open situations; because in them the bark is thick and coarse to resist the cold; the stems stout and short, and the head extensive with the lower branches spreading, to resist the wind.

3957. *The machine for transplanting large trees* adopted by Sir Henry Stuart, is an improvement of one which has been very long in general use. It consists of a pole (*fig. 592. a a*) 15 feet long, attached to an axle and a pair of wheels, on which is placed a block (*b*), which may be of any convenient height, with a pillow (*c*), and two rings for attaching the draught chains (*d*). It is easy to conceive the application of this pole, axle, and wheels, to a large tree, and its removal by men or horses to its intended destination (*fig. 593*). (*Planter's Guide*, sect. viii. 2d edit.)



593



SECT. IV. *Mixture of Trees in Plantations.*

3958. *The object of mixing trees in plantations* is threefold: that of sheltering the weaker but ultimately more valuable kinds by the stronger and bardier; that of drawing as much profit from the soil as possible; and that of producing variety of appearance.

3959. *With respect to shelter*, many situations are so exposed, that it is extremely difficult to rear trees without some mode of protecting them from the cold winds of spring during their early growth. This is sometimes done by walls, the extent of whose influence, however, is but very limited; by thick planting; or by planting the more hardy and rapid-growing species, to nurse up and protect such as are more tender, but ultimately more valuable. The proportion of nurses to principals is increased according to the bleakness of the site: Pontey says, "Both authors and planters are in the habit of erring egregiously, in regard to the proportion of principals and nurses, as they generally use as many or more of the former than the latter, though it is very easy to show, that they ought to use three times as many of the latter as the former. For instance, when trees are planted at four feet apart, each occupies a surface of sixteen feet; of course, four of them will occupy sixty-four, or a square of eight feet; and, therefore, if we plant three nurses to one principal tree, all the former might be displaced gradually, and the latter would still stand only eight feet apart."

3960. *Nurse plants* should, in every possible case, be such as are most valued at an early period of growth. The larch and spruce fir should be used liberally, in every case where they will grow freely; still it is not intended they should exclude all others, more particularly the birch, which has most of the properties of a good nurse, such as numerous branches and quick growth, on any tolerable soil or situation. It is not, however, like the others, a wood of general application. (*Profitable Planter*, p. 113.) Sang also adopts the proportion of three nurses to one principal, and employs chiefly the resinous tribe, and looks to them for reimbursement till the hard timber has attained to a foot in diameter, under which size hard timber is seldom of much value. His principals are planted at from six to ten feet apart, according to the soil and situation. (*Plant. Kal.* p. 166.)

3961. *In procuring shelter*, much depends on the mode of commencing and continuing plantations on bleak sites. Sang, who has had extensive experience in this part of planting, observes, that "every plain, and most fields and situations for planting in this country, have what may be called a windward side, which is more exposed to the destructive blast than any other. It is of great importance to be apprised of this circumstance, and to be able to fix upon the most exposed side of the proposed forest plantation. Fix, then, upon the windward side of the space which is to be converted into a forest, mark off a horizontal stripe or belt, at least a hundred yards in breadth. Let this portion of ground be planted thick, say at the distance of thirty inches, or at the most three feet, with a mixture of larch, sycamore, and elder, in equal quantities or nearly so, if the soil be adapted for rearing these; but if it be better adapted for Scots pines, then let it be planted with them at the distances prescribed for the above mixture. We have no other kinds that will thrive better, or rise more quickly in bleak situations, than those just mentioned. When the trees in this belt or zone have risen to the height of two feet, such hard-wood trees as are intended ultimately to fill the ground should be introduced, at the distance of eight or ten feet from each other, as circumstances may admit. At this period or perhaps a year or two afterwards, according to the bleak or exposed situation of the grounds, let another parallel belt or zone, of nearly equal breadth, be added to the one already so far grown up, and so on, till the whole grounds be covered. It is not easy here to determine on the exact breadth of the subsequent belt or zones; this matter must be regulated by the degree of exposure of the grounds, by the shelter afforded by the zone previously planted, and by such like circumstances." (*Plant. Kal.* p. 29.)

3962. *In situations exposed to the sea breeze a similar plan* may be successfully followed, and aided in effect by beginning with a wall; the first zone having reached the height of the wall, plant a second, a third, and fourth, and so on till you cover the whole tract to be wooded. In this way the plantations on the east coast of Mid Lothian, round Gosford House, were reared; in Sang's manner, the mountains of Blair and Dunkeld were clothed; and examples, we are informed, might be drawn from the Orkney and Shetland Islands.

3963. *The practice of mixing trees*, with a view to drawing as much nourishment from the soil as possible, and giving, as it used to be said, more chances of success, was till very lately generally approved of. Marshal advises mixing the ash with the oak; because the latter draws its nourishment chiefly from the subsoil, and the former from the surface. Nicol is an advocate for indiscriminate mixture (*Practical Planter*, p. 77.), and Pontey says, "Both reason and experience will fully warrant the conclusion, that the greatest possible quantity of timber is to be obtained by planting mixtures." (*Prof. Planter*, p. 119.) "We are clearly of opinion," says Sang, "that the best method is to plant each sort in distinct masses or groups, provided the situation and quality of the soil be properly kept in view. There has hitherto been too much random work carried on with respect to the mixture of different kinds. A longer practice, and more experience, will discover better methods in any science. That of planting is now widely extended, and improvements in all its branches are introduced. We, therefore, having a better knowledge of soils, perhaps, than our forefathers had, can with greater certainty assign to each tree its proper station. We can, perhaps, at sight, decide that here the oak will grow to perfection, there the ash, and here again the beech; and the same with respect to the others. If, however, there happen to be a piece of land of such a quality, that it may be said to be equally adapted for the oak, the walnut, or the Spanish chestnut, it will be proper to place such in it, in a mixed way, as the principals; because each sort will extract its own proper nourishment, and will have an enlarged range of pasturage for its roots, and consequently may make better timber trees."

3964. *Cobbett*, who, though by no means a scientific cultivator, has in general very sound practical views, is decidedly in favour of planting in masses; and would have all the trees not only of one and the same sort, but of the same size and height. (*Woodlands*, § 85.)

3965. *By indiscriminately mixing* different kinds of hard wood plants in a plantation, there is hardly a doubt that the ground will be fully cropped with one kind or other; yet it very often happens, in cases when the soil is evidently well adapted to the most valuable sorts, as the oak perhaps, that there is hardly one oak in the ground for a hundred that ought to have been planted. We have known this imperfection in several instances severely felt. It not unfrequently happens, too, that even what oaks or other hard-wood trees are to be met with, are overtopped by less valuable kinds, or perhaps such, all things considered, as hardly deserve a place. Such evils may be prevented by planting with attention to the soil, and in distinct masses. In these masses are insured a full crop, by being properly nursed for a time with kinds more hardy, or which afford more shelter than such hard-wood plants. There is no rule by which to fix the size or extent of any of these masses. Indeed, the more various they are made in size, the better will they, when grown up, please the eye of a person of taste. They may be extended from one acre to fifty or a hundred acres, according to the circumstances of soil and situation: their shapes will accordingly be as various as their dimensions. In the same manner ought all the resinous kinds to be planted, which are intended for timber trees; nor should these be intermixed with any other sort, but be in distinct masses by themselves. The massing of larch, the pine, and the fir of all sorts, is the least laborious and surest means of growing good, straight, and clean timber. It is by planting or rather by sowing them in masses, by placing them thick, by a timely pruning and gradual thinning, that we can with certainty attain this object. (*Plant. Kal.* 162 and 166.) Our opinion is in perfect consonance with that of *Sang*, and for the same reasons; and we may add, as an additional one, that in the most vigorous natural forests one species of tree will generally be found occupying almost exclusively one soil and situation, while, in forests less vigorous, on inferior and watery soils, mixtures of sorts are more prevalent. This may be observed by comparing New Forest with the natural woods round Lochlomond, and it is very strikingly exemplified in the great forests of Poland and Russia.

3966. *With respect to the appearance of variety*, supposed to be produced by mixing a number of species of trees together in the same plantation, we deny that variety is produced. Wherever there is variety, there must be some marked feature in one place, to distinguish it from another; but in a mixed plantation the appearance is every where the same; and ten square yards at any one part of it will give nearly the same number and kinds of trees as ten square yards at any other part. "There is more variety," *Repton* observes, "in passing from a grove of oaks to a grove of firs, than in passing through a wood composed of a hundred different species, as they are usually mixed together. By this indiscriminate mixture of every kind of tree in planting, all variety is destroyed by the excess of variety, whether it is adopted in belts, clumps, or more extensive masses. For example, if ten clumps be composed of ten different sorts of trees in each, they become so many things exactly similar; but if each clump consists of the same sort of tree, they become ten different things, of which one may hereafter furnish a group of oaks, another of elms, another of chestnuts or of thorns, &c. In like manner, in the modern belt, the recurrence and monotony of the same mixture of trees of all the different kinds, through a long drive, make it the more tedious, in proportion as it is long. In part of the drive at *Woburn*, evergreens alone prevail, which is a circumstance of grandeur, of variety, of novelty, and, I may add, of winter comfort, that I never saw adopted in any other place, on so magnificent a scale. The contrast of passing from a wood of deciduous trees to a wood of evergreens must be felt by the most heedless observer; and the same sort of pleasure, though in a weaker degree, would be felt, in the course of a drive, if the trees of different kinds were collected in small groups or masses by themselves, instead of being blended indiscriminately." (*Enquiry into Changes of Taste*, &c. p. 23.)

3967. *Sir William Chambers and Price* agree in recommending the imitation of natural forests in the arrangement of the species. In these, Nature disseminates her plants by scattering their seeds, and the offspring rise round the parent in masses or breadths, depending on a variety of circumstances, but chiefly on the facility which these seeds afford for being carried to a distance by the wind, the rain, and by birds or other animals. At last that species which had enjoyed a maximum of natural advantages is found to prevail as far as this maximum extended, stretching along in masses and irregular portions of surface, till, circumstances changing in favour of some other species, that takes the precedence in its turn. In this way it will be generally found, that the number of species, and the extent and style of the masses in which they prevail, bear a strict analogy to the changes of soil and surface; and this holds good, not only with respect to trees and shrubs, but to plants, grasses, and even mosses.

SECT. V. *Culture of Plantations.*

3968. *A tree, when once planted, most men consider to be done with*; though, as every one knows, the progress and products of trees, like those of other plants, may be greatly increased or modified by cultivating the soil, by pruning, and by thinning. Before proceeding to these subjects, we shall submit some remarks on the influence of culture on the progress of the growth of trees, and on the strength and durability of timber.

SUBSECT. 1. *General Influence of Culture on Trees.*

3969. *The effect of culture on herbaceous vegetables* is so great, as always to change their appearance, and often, in a considerable degree, to alter their nature. The common culinary vegetables, and cultivated grasses, assume so different an appearance in our fields and gardens, from what they do in a state of wild nature, that even a botanist might easily be deceived in regard to the species. The same general laws operate upon the whole kingdom of vegetables; and thence it is plain, that the effects of culture on trees, though different in degree, must be analogous in their nature. (*Treatise on Country*

Resid. vol. ii.) In the same manner, the absence of culture, or the removing of the vegetable to a colder climate and a worse soil, tends to contract or consolidate the parts of the plant. (*Planter's Guide.*)

3970. *The effect of culture on woody plants* is similar to that on culinary vegetables and cultivated grasses; but the law operates of course less rapidly, owing to the less rapid growth of trees, from the lowest bush to the oak of the forest. In all of these, the culture of the soil tends to accelerate vegetation, and, by consequence, to expand the fibre of the wood. It necessarily renders it softer, less solid, and more liable to suffer by the action of the elements.

3971. *The effect of culture on the ligneous plants in common use in planting and gardening* is readily exemplified. Every forester is aware how much easier it is to cut over thorns or furze trained in hedges, than such as grow naturally wild, and are exempt from culture. Gardeners experience the same thing in pruning or cutting over fruit trees, or shrubs; and the difference in the texture of the raspberry, in its wild and in its cultivated state, is as remarkable; for, although the stem, in the latter case, is nearly double the thickness to which it attains in the former, it is much more easily cut. On comparing the common crab, the father of our orchards, with the cultivated apple, the greater softness of the wood of the latter will be found not less striking to every arboriculturist. The common oak in Italy and Spain, where it grows faster than in Britain, is ascertained to be of shorter duration in those countries. In the same way, the oak in the highland mountains of Scotland or Wales is of a much harder and closer grain, and therefore more durable, than what is found in England; though on such mountains it seldom rises to the fifth part or less of the English tree. Every carpenter in Scotland knows the extraordinary difference between the durability of Highland oak, and oak usually imported from England, for the spokes of wheels. Every extensive timber dealer is aware of the superior hardness of oak raised in Cumberland and Yorkshire, over that of Monmouthshire and Herefordshire; and such a dealer, in selecting trees in the same woods in any district, will always give the preference to oak of slow growth, and found on cold and clayey soils, and to ash on rocky cliffs, which he knows to be the soils and climates natural to both. If he take a cubic foot of park-oak, and another of forest-oak, and weigh the one against the other, (or if he do the like with ash and elm of the same descriptions,) the latter will uniformly turn out the heavier of the two. The Scotch pine does not stand longer than forty or fifty years on the rich and fertile land in both England and Scotland, where it is often planted, and where it rushes up with extraordinary rapidity. In the northern districts of Scotland, on the other hand, the difference between park pine and Highland pine is universally known and admitted, and the superiority of the latter is proved by its existence in buildings of great antiquity, where it is still found in a sound state; a difference which can be ascribed to no other cause than the mountainous situations (that is, the natural state) in which the former timber is produced, and where, the trees being of slower growth, the wood is consequently of a harder texture. A friend of Sir Henry Steuart's felled some larch trees, which had grown nearly fifty years in a deep rich loam, close to some cottages and cabbage gardens. The wood was soft and porous, and of no duration; it was even found to burn as tolerable firewood, which larch of superior quality is never known to do. (*Tr. on Coun. Res., and Planter's Guide.*)

3972. *The general effect of pruning* is to increase the quantity of timber produce. The particular manner in which it does this is by directing the greater part of the sap, which generally spreads itself in side-branches, into the principal stem. This must consequently enlarge that stem in a more than ordinary degree, by increasing the annual circles of the wood. Now, if the tree be in a worse soil and climate than those which are natural to it, this will be of some advantage, as the extra increase of timber will still be of a quality *not inferior* to what would take place in its natural state; or, in other words, it will correspond with that degree of quality and quantity of timber, which the nature and species of the tree admit of being produced. If the tree be in its natural state, the annual increase of timber, occasioned by pruning, must necessarily injure its quality, in a degree corresponding with the increased quantity. If the tree be in a better climate and soil than that which is natural to it, and, at the same time, the annual increase of wood be promoted by pruning, it is evident that such wood must be of a very different quality from that produced in its natural state (that is, very inferior). Whatever, therefore, tends to increase the wood in a greater degree than what is natural to the species, when in its natural state, must injure the quality of the timber. Pruning tends to increase this in a considerable degree, and, therefore, it must be a pernicious practice, in as far as it is used in these cases. Pruning is not here considered in regard to eradicating diseases, preventing injuries, or increasing the natural character and tendency of trees: for those purposes it is of great advantage. Mr. Knight has shown, in a very striking manner, that timber is produced, or rather, that the alburnum or sapwood is rendered ligneous, by the motion of the tree, during the descent of the true (or proper) sap. It

is also sufficiently known to all who have attended to the physiology of vegetables, and is greatly confirmed by some experiments laid before the Royal Society (*Phil. Trans.* 1803, 1804), that the solid texture of the wood greatly depends upon the quantity of sap which must necessarily descend, and also on the slowness of its descent. Now, both these requisites are materially increased by side branches, which retain a large quantity of sap, and by their junction with the stem occasion a contraction, and twisted direction of the vessels, which obstructs the progress of the (proper) juice. That this is true, in fact, is well known to those accustomed to make wine from maple and birch trees; for in this business it is found, that those trees which have fewest side branches bleed more freely than the others, but during a much shorter space of time. These hints, therefore, afford additional evidence against pruning, and particularly against pruning fir-trees; which, as Mr. Knight justly observes, have larger vessels than the others, and, therefore, when in an improved soil and climate, side branches, for the purposes above mentioned, are essentially necessary to them, if solid, resinous, and durable timber be the object in view. (*Sir Henry Steuart's Planter's Guide*, p. 444.)

3973. *Sir Henry Steuart*, concurring in these facts and observations, deduces the following practical conclusions respecting the influence of culture:—

3974. *First*; that all timber trees thrive best, and produce wood of the best quality, when growing in soils and climates most natural to the species. It should, therefore, be the anxious study of the planter, to ascertain and become well acquainted with these, and to raise trees, as much as possible, in such soils and climates.

3975. *Secondly*; that trees may be said to be in their natural state, when they have sprung up fortuitously, and propagated themselves without aid from man, whether it be in aboriginal forests, ancient woodlands, commons, or the like. That in such trees, whatever tends to increase the wood, in a greater degree than accords with the species when in its natural state, must injure the quality of the timber.

3976. *Thirdly*; that whatever tends to increase the growth of trees, tends to expand their vegetable fibre. That when that takes place, or when the annual circles of the wood are soft, and longer than the general annual increase of the tree should warrant, then the timber must be less hard and dense, and more liable to suffer from the action of the elements.

3977. *Fourthly*; that a certain slowness of growth is essentially necessary to the closeness of texture and durability of all timber, but especially of the oak; and that, whenever the growth of that wood is unduly accelerated by culture of the soil (such as by trenching and manuring), or by undue superiority of climate, it will be injured in quality in the precise ratio in which those agents have been employed.

3978. *Fifthly*; that, as it is extremely important for the success of trees, to possess a certain degree of vigour in the outset, or to be what is technically called, "well set off," the aid of culture is not in every case to be precluded, by a consideration of the general rule. That if trees be in a soil and climate worse than those that are natural to them, then culture will be of some advantage; as the extra increase of wood will be of a quality not inferior to what, in its natural state, it would obtain; or, in other words, it will correspond with that degree of quality and quantity of timber, which the nature of the species admits of being obtained: but culture in this case must be applied with cautious discrimination, and a sound judgment. That, on the other hand, if trees be in a better soil and climate than are natural to them, and, at the same time, that the annual increase of wood be promoted by culture (as already said), it will be a decided disadvantage, and deteriorate the wood. In the same way, if trees be in their natural state, the annual increase of timber, obtained by culture, will injure its quality, in a degree corresponding with the increased quantity.

3979. *Sixthly*; that such appears to be a correct, though a condensed view of the operation of those general laws respecting growth, which govern the whole vegetable kingdom, and especially of their effects on woody plants, and of the salutary restraints, which science dictates to be laid on artificial culture, of which pruning, as well as manuring, forms a constituent part, as has been explained above, at so much length. That it is by a diligent study of the peculiar habits of trees, and the characters of soils, illustrated and regulated by facts drawn from general experience, that rash or ignorant systems of arboriculture are to be best corrected, and science brought most beneficially to bear on general practice." (*Planter's Guide*, 2d edit. p. 478.)

SUBJECT. 2. *Culture of the Soil among Trees.*

3980. *With respect to the culture of the soil*, it is evident, that young plantations should be kept clear of such weeds as have a tendency to smother the plants; and though this is not likely to take place on heaths and barren sites, yet even these should be looked over once or twice during summer, and at least those weeds removed which are conspicuously injurious. In grounds which have been prepared previously to planting, weeding, hoeing by hand or by the horse hoe, and digging or ploughing (the two latter rarely), become necessary according to circumstances. The hoeings are performed in summer to destroy weeds, and render the soil pervious to the weather; the ploughing and diggings in winter are for the same purpose, and sometimes to prepare the soil for spring crops. These, both *Pontey* and *Sang* allow, may be occasionally introduced among newly planted trees; though it must not be forgotten that, relatively to the trees, the plants composing such crops are weeds, and some of them, as the potato, weeds of the most exhausting kind. *Sang* uses a hoe of larger size than usual. (*fig.* 590. *d.*) In preparing lands for sowing woods, *Sang* ploughs in manure, sows in rows six feet apart, by which he is enabled to crop the ground between with low-growing early potatoes, turnips, and lettuce; but not with young trees as a sort of nursery, as they prove more scourging crops than esculent vegetables; nor with grain, as not admitting of culture, and being too exhausting for the soil. *Marshal*, and some other authors, however, approve of sowing the tree seeds with a crop of grain, and hoeing up the stubble and weeds when the crop is removed.

3981. *Pontey* observes, "that wherever preparing the soil for planting is thought necessary, that of cultivating it for some years afterwards will generally be thought the

same, slight crops of potatoes with short tops, or turnips, may be admitted into such plantations with advantage for two or three years, as they create a necessity for annually digging or stirring the surface, and tend very materially to accelerate the growth of the plants. It may be objected, that such crops must impoverish the soil, and no doubt such is the fact, so far as common vegetables are concerned: but as to the production of wood, its support depends, in a great measure, on a different species of nutriment; and hence, I could never observe, that such cropping damaged it materially." (*Profit. Plant.* p. 153.)

3982. *Osier plantations*, for baskets, willows, and hoops, require digging and cleaning during the whole course of their existence; and so do hedgerows to a certain extent, and some ornamental plantations.

SUBSECT. 3. *Filling up of Blanks or Failures in Plantations.*

3983. *The filling up of blanks* is one of the first operations that occurs on the culture of plantations, next to the general culture of the soil, and the care of the external fences. According to Sang, "a forest plantation, either in the mass form or ordinary mixture, should remain several years after planting, before filling up the vacancies, by the death of the hard-wood plants, takes place. Hard-wood plants, in the first year, and even sometimes in the second year, after planting, die down quite to the surface of the ground, and are apparently dead, while their roots, and the wood immediately above them, are quite fresh, and capable of producing very vigorous shoots, which they frequently do produce, if allowed to stand in their places. If a tree, such as that above alluded to, be taken out the first or second year after planting, and the place filled up with a fresh plant of the same kind, what happened to the former may probably happen to the latter; and so the period of raising a plant on the spot may be protracted to a great length of time; or it is possible this object may never be gained.

3984. *The filling up of the hard-wood kinds* in a plantation which has been planted after trenching or summer fallow, and which has been kept clean by the hoe, may be done with safety at an earlier period than under the foregoing circumstances; because the trees, in the present case, have greater encouragement to grow vigorously after planting, and may be more easily ascertained to be entirely dead, than where the natural herbage is allowed to grow among them.

3985. *But the filling up of larches and pines* may take place the first spring after the plantation has been made; because such of these trees as have died are more easily distinguished. In many cases where a larch or pine loses its top, either by dying down, or the biting of hares or rabbits, the most vigorous lateral branch is elected by nature to supply the deficiency, which by degrees assumes the character of an original top. Pines, and larches, therefore, which have fresh lateral branches, are not to be displaced, although they have lost their tops. Indeed, no tree in the forest, or other plantation, ought to be removed until there be no hope of its recovery.

3986. *If the filling up of plantations be left undone till the trees have risen to fifteen or twenty feet in height*, their roots are spread far abroad, and their tops occupy a considerable space. The introduction of two or three plants, from a foot to three feet in height, at a particular deficient place, can never, in the above circumstances, be attended with any advantage. Such plants may, indeed, become bushes, and may answer well enough in the character of underwood, but they will for ever remain unfit for any other purpose. It is highly improper then, to commence filling up hard-wood plantations before the third year after planting; or to protract it beyond the fifth or the sixth. March is the proper season for this operation. (*Plant. Kal.* 295.)

SUBSECT. 4. *Pruning and Heading down Trees in Plantations.*

3987. *Pruning is the most important operation of tree culture*, since on it, in almost every case, depends the ultimate value, and in most cases the actual bulk, of timber produced. For pruning, as for most other practical purposes, the division of trees into resinous or frondose-branched trees, and into non-resinous or branchy-headed sorts, is of use. The main object in pruning frondose-branched trees is to produce a trunk with clean bark and sound timber; that in pruning branchy-stemmed trees is principally to direct the ligneous matter of the tree into the main stem or trunk, and also to produce a clean stem and sound timber, as in the other case. The branches of frondose trees, unless in extraordinary cases, never acquire a timber size, but rot off from the bottom upwards, as the tree advances in height and age; and, therefore, whether pruned or not, the quantity of timber in the form of trunk is the same. The branches of the other division of trees, however, when left to spread out on every side, often acquire a timber-like size; and as the ligneous matter they contain is in general far from being so valuable as when produced in the form of a straight stem, the loss by not pruning off their side branches or preventing them from acquiring a timber-like size is evident. On the other hand, when they are broken off by accident, or rot off by being crowded together, the

timber of the trunk, though in these cases increased in quantity, is rendered knotty and rotten in quality.

3988. *Pruning frondose or resinous trees* is one of the greatest errors in the modern system of forest management. The branches of the different species of pines, and of the cedar of Lebanon, never attain a timber size, if growing in a moderately thick plantation; those of the fir tribe never under any circumstances. Provided pines and cedars, therefore, are planted moderately thick, no loss in point of timber can ever be sustained by omitting altogether to prune them; and in this respect the fir tribe, whether thick or thin on the ground, may be left to themselves. The important question is, how does the rotting off of the branches affect the timber in the trunk of the tree? Certainly no pine or fir timber can be sounder or better than that which is brought from the native forests of the north of Europe, and from America, where no pruning is ever given. The rotting off of the frondose branches, therefore, cannot be injurious in these countries. The next question is, can it be proved to be injurious in this country? We are not aware that it has, and do not believe that it can. The rotting off of the branch of a resinous tree is a very different process from the rotting off of a branch of a ramose-headed tree. This fact may be verified by observing what takes place in pine or fir woods, and by inspecting the interior of foreign pine or fir, cut up into planks. In the rotting off of side branches of deciduous trees, we find, that the principal part where decay operates, at least in all the soft woods, and even in the oak when it is young, is the heart; but in the rotting off of the side branches of resinous trees, we shall find them decaying chiefly on the outside, and wearing down the stump of the fallen branch in the form of a cone. On examining the sections of sound foreign deal, we shall find that the knots of the side branches always terminate in cones when the section is made vertically. This is a fact well known to every carpenter; and it is also known to a great many, that British pine and fir timber that has been pruned, has invariably a rotten space at every knot. The same thing is observable to a certain extent in the natural decay of the side branches of all trees. When the decay is natural, it commences at the circumference, and wears down the stump, till it ends in a small hard cone, which is buried in the increasing circumference of the tree, and is never found injurious to the timber: when the decay is artificial, or in consequence of excessive pruning, that is, suddenly exposing a large section to the action of the atmosphere, the bark protects the circumference, and the decay goes on in the centre, so as to end in forming an inverted cone of rotten matter, which serves as a funnel to conduct moisture to the trunk, and thereby render it rotten also. The conclusion which we draw from these facts is, that the pine and fir tribe should scarcely be pruned at all, and that no branches of ramose trees should be cut off close to the stem of a larger size than what may be healed over in one or at most two seasons. We agree with Cruickshank, therefore, when he says, "It would appear that the pruning of firs [the pine and fir tribe], supposing it harmless, can yet be productive of no positive good."

3989. *Cruickshank, Pontey, and Sang*, agree that the great object of pruning is to protect the leader or main stem or shoot from the rivalry of the side branches, in order that as much of the nourishment drawn from the soil may be employed in the formation of straight timber, and as little in the formation of branches and spray, as is consistent with the economy of vegetation. Without the agency of the leaves, the moisture absorbed from the soil could no more nourish a plant than the food taken into the stomach would nourish an animal without the process of digestion. The branches bearing the leaves are therefore just as necessary to the welfare of the tree as the roots. By taking away too many of the branches, only a small part of the fluid imbibed will be elaborated; by leaving the branches too thick and crowded, the leaves may be less perfect, and less fit for performing their office, than they otherwise would be. Exposure of a part of the branches to the light and air may therefore be a sufficient reason for thinning them, independently of increasing the trunk. "How," asks Cruickshank, "are we to know the exact number of branches that may be removed with safety in any given circumstances? Never, it is answered, displace any which have not already got, or seem in immediate danger of getting, the upper hand of the leader. These will be known by their equalling or approaching the leader in size; or, to speak less ambiguously, by their being of the same, or nearly of the same, girth at the place where they spring from the stem, as the *stem itself* is at *their length* from *its top*." In proceeding according to this plan, the pruner is not to regard, in the smallest degree, the part of the stem on which a shoot is situated. If it is too large, it must be displaced, should it be in the highest part of the tree: if it is not too large, it must remain, though it be close to the ground.

"But how will this method, the reader may be ready to ask, ever produce a clean stem? By repeating the pruning, it is answered, as often as the growth of the branches may make the operation necessary. Suppose, the first time a tree undergoes the process, that the branches removed are a considerable distance from the ground, and that there are several smaller ones left growing farther down the stem: these last will gradually increase in size, till they, too, must be lopped off, and thus the stem will be in the end as effectually cleared, though more gradually, and consistently with the health of the tree, as by the absurd method represented above.

"If any branches that were left at a former pruning low on the stem, appear at the next repetition of the process not to have increased in size, we may safely conclude that they have had no influence on the tree either good or bad; and as it would be in vain to leave them with the hope that they will any longer assist in the elaboration of the sap, they should be removed, as unsightly objects which it is no longer useful to preserve." (*Practical Planter*, p. 168.)

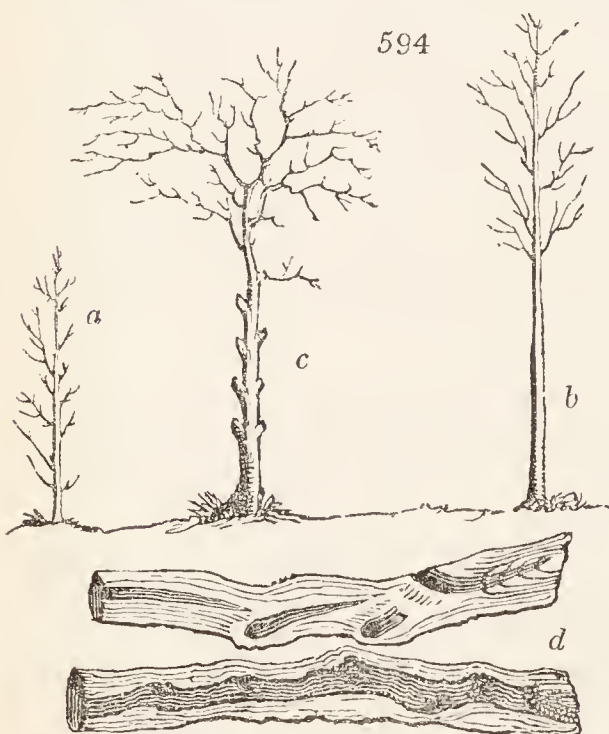
3990. *Billington* considers the leaves and branches of trees as of the greatest importance: he thinks every timber tree ought to have the trunk clothed with branches throughout; but these branches he would shorten in such a way that they should never engross any material part of the timber of the tree. To accomplish this, it is necessary to commence pruning when the trees are young, by which means the great bulk of the timber produced will be deposited in the main stem or trunk. This is what he calls *preventive pruning*. (*Gard. Mag.* vol. vi.) A similar system had been recommended by Mr. Blaikie of

Holkham, under the name of *foreshortening*, and is advocated by Sir Henry Steuart, under that of *terminal pruning*.

3991. *Most erroneous opinions on the subject of pruning resinous trees* have been propagated by Salmon, the experienced manager of the late Duke of Bedford, Pontey, forest-pruner to the same duke, and others of less note. Sang, on the other hand, argues against excessive pruning of the resinous tribe of trees as injurious to the health of the tree and the soundness of its timber. Elles, also, a gardener of scientific acquirements, and extensive experience in England, his native country, and in Scotland and Ireland, would never prune the pine and fir tribe at all, unless when very young, and when the side shoots could be pinched off with the finger and the thumb. At a more advanced age, if compelled by circumstances to prune, he would only shorten the extremities of the fronds. Of two trees, pines, firs, cedars, or larches, the one pruned and the other unpruned, there will be found, he says, most timber in the trunk of the unpruned one, while the branches are so much in addition to the value of the tree. He excepts, of course, those cases in which frondose branches take a ramose character, in consequence of the tree standing alone, as is frequently the case with the cedar of Lebanon, and sometimes with the Scotch pine.

3992. *Our own opinion* with respect to pruning the resinous trees is in accord with that of Elles and Cruickshank; and as to hard and soft wooded leaf trees, we think Cruickshank's practice and rule unexceptionable. We would prune the last description of trees much less than is generally done, and leave the pine and fir tribe in a great measure to nature, taking care, however, to thin betimes and occasionally from infancy till the maturity of the trees. We have no doubt of this, that when the larch and Scotch pine trees planted in the end of the last century, and severely pruned for the first twenty or twenty-five years of the present, shall come to be cut down and sawn up, their timber will be found full of faults, and of very little value, compared with timber of the same sorts from natural and unpruned woods, foreign and domestic.

3993. *With respect to the manner of pruning*, Sang observes, "Where straight timber is the object, both classes in their infancy should be feathered from the bottom upwards,



keeping the tops light and spiral, something resembling a young larch (*fig. 594. a*). The proportion of their tops should be gradually diminished, year by year, till about their twentieth year, when they should occupy about a third part of the height of the plant; that is, if the tree be thirty feet high, the top should be ten feet (*b*). In all cases in pruning off the branches, the utmost care must be taken not to leave any stumps sticking out, but cut them into the quick. It is only by this means that clean timber can be procured for the joiner; or slightly stemmed trees to please the eye. It is a very general practice to leave snags or stumps (*c*): before the bole can be enlarged sufficiently to cover these, many years must elapse; the stumps in the mean time become rotten; and the consequence is, timber which, when sawn up (*d*), is only fit for fuel."

3994. *The general seasons of pruning* are winter and spring, and for the gean or wild cherry midsummer, as it is found to gum very much at any other season. Pontey says, "As to the proper seasons of pruning, there is only one difficulty; and that is, discovering the wrong one, or the particular time that trees will bleed. Only two trees have been found which bleed uniformly at certain seasons, namely, the sycamore and fir, which bleed as soon as the sap begins to move." There is, however, one season for pruning unquestionably preferable to all others, as far as the welfare of the tree, and the soundness of its future timber, is concerned. It is well known to physiologists and observing gardeners, that when the sap is returning, wounds heal with the greatest rapidity. Hence, in all plants which are difficult to strike from cuttings, the gardener makes choice of the point of a shoot in that particular stage of maturation when the sap is returning; that is, when the base of the shoot is beginning to assume a ligneous character. This, in hardy trees, is uniformly a week or a fortnight after midsummer, and it will be found that the wounds made by cutting off branches at that season, or any time within three weeks after midsummer, will, in the course of four or five weeks, be partly covered with a callosity proceeding from the lips of the wound. Wounds made by cutting branches off the same trees, five weeks after midsummer, will remain without the slightest indi-

cation of healing at the edges till the following spring ; and if the tree is delicate, or the winter severe, they will then be in a worse condition than if they had not been pruned at all ; the lips of the wounds will have begun to decay. The only seeming contradiction to this general law in trees is where what are called second growths are produced, as in the oak and some other trees, and in such cases there is of course a second returning sap, for the same reason that there was at first. (*Gard. Mag.* vol. vi. p. 94.)

3995. *In spring pruning*, desist when bleeding takes place. As a general rule, Pontey thinks "summer preferable to winter pruning ; because, in proportion as wounds are made early they heal so much more in the same season." (*Forest Pruner*, 236.) Sang suspends pruning from the end of February to the middle of July, but carries it on during every other month of the year ; pruning the wild cherry, or any other tree very apt to gum, only in July and August. (*Plant. Kal.* 268.)

3996. *With respect to the implements to be used*, Sang observes, "In every case where the knife is capable of lopping off the branch in question, namely, in the pruning of infant plants, it is the only instrument necessary. All other branches should be taken off by the saw. A hatchet, or a chisel, should never be used. Every wound on the stem or bole should be quite into the quick, that is, to the level and depth of the bark ; nor should the least protuberance be left. The branch to be lopped off by the saw should, in all cases, be notched or slightly cut on the under side, in order to prevent the bark from being torn in the fall ; and when the branch has been removed, the edges of the wound, if anywise ragged, should be pared smooth with the knife. If the tree be vigorous, nature will soon cover the wound with the bark, without the addition of any plaster to exclude the air. In the shortening of a strong branch, the position of which is pretty upright, it should be observed to draw the saw obliquely across it, in such a manner as that the face of the wound shall be incapable of retaining moisture ; and afterwards to smooth the edges of the bark with a knife." (*Plant. Kal.* 181.) In every case where the branches are too large for the knife, Pontey prefers the saw, as the best and most expeditious instrument ; and one, the use of which is more easily acquired by a labourer than that of either the bill or axe. In "large work" he uses the common carpenter's saw ; for smaller branches, one with somewhat finer teeth, with the plate of steel, about twenty inches long.

3997. *The pruning of all deciduous trees should be begun at the top*, or at least those branches which are to be removed thence should never be lost sight of. "Having fixed upon what may be deemed the best shoot for a leader, or that by which the stem is most evidently to be elongated and enlarged, every other branch on the plant should be rendered subservient to it, either by removing them instantly, or by shortening them. Where a plant has branched into two or more rival stems, and there are no other very strong branches upon it, nothing more is required than simply to lop off the weakest clean by the bole, leaving only the strongest and most promising shoot. If three or four shoots or branches be contending for the ascendancy, they should, in like manner, be lopped off, leaving only the most promising. If any of the branches which have been left farther down on the bole of the plant at former prunings have become very strong, or have extended their extremities far, they should either be taken clean off by the bole, or be shortened at a proper distance from it, observing always to shorten at a lateral twig of considerable length. It is of importance that the tree be equally poised ; and, therefore, if it have stronger branches on the one side than on the other, they should either be removed or be shortened. Thus, a properly trained tree, under twenty feet in height, should appear light and spiral, from within a yard or two of the ground to the upper extremity, its stem being furnished with a moderate number of twigs and small branches, in order to detain the sap, and circulate it more equally through the plant.

3998. *The subsequent prunings of trees of this size*, standing in a close plantation, will require much less attention ; all that is wanted will consist in keeping their leading shoots single. From the want of air, their lateral branches will not be allowed to extend, but will remain as twigs upon the stem. These, however, frequently become dead branches ; and if such were allowed to remain at all on the trees, they would infallibly produce blemishes calculated greatly to diminish the value of the timber : hence the impropriety of allowing any branch to die on the bole of a tree ; indeed, all branches should be removed when they are alive ; such a method, to our knowledge, being the only sure one to make good timber. From these circumstances, an annual pruning, or at least an annual examination, of all forests is necessary. (*Plant. Kal.*)

3999. *Heading down* such non-resinous trees as stole, we have already stated to be an important operation. After the trees have been three or four years planted, Sang directs, that "such as have not begun to grow freely should be headed down to within three or four inches of the ground. The cut must be made with the pruning-knife in a sloping direction, with one effort. Great care should be taken not to bend over the tree in the act of cutting. By so bending, the root may be split, a thing which too often happens. The operation should be performed in March, and not at an earlier period of the season, because the wounded part might receive much injury from the severe weather in January and February, and the expected shoot be thereby prevented from rising so strong and vigorous." (*Plant. Kal.* 297.) Buffon, in a *Memorial on the Culture of Woods*, presented to the French government in 1742, says he has repeated this experiment so often, that he considers it as the most useful practice he knows in the culture of woods.

4000. *For the purpose of producing bends for ship-timber*, various modes of pruning have been proposed, as such bends always fetch the highest price. According to Pontey, "little is hazarded by saying, that if plenty of long, clean, straight, free-grown trees could be got, steaming and a screw apparatus would form bends."

4001. *Monteith*, a timber valuator of great experience, and in extensive practice, says, the value of the oak, the broad-leaved elm, and Spanish chestnut, depends a good deal on their being crooked, as they are all used in ship building. He says he has seen trees successfully trained into crooked shapes of great value, in the following manner :—"If you have an oak, elm, or chestnut, that has two stems, as it were, striving for the superiority, lop or prune off the straightest stem ; and if a tree that is not likely to be of such value be standing on that side to which the stem left seems to incline to a horizontal position, take away the tree, and thus give the other every chance of growing horizontally. At this time it will be necessary to take away a few of the perpendicular shoots off the horizontal branch ; and, indeed, if these branches, which is sometimes the case in such trees, seem to contend, take away most of them ; but if they do not, it is better at this time not to prune over much, except the crooked shoots on the horizontal branch, till they arrive at the height of fifteen or even twenty feet. By this time it will be easily seen

what kind of tree it is likely to form ; and, if it inclines to grow crooked, lighten a little the top of the tree, by taking off a few of the crooked branches on the straighter side, allowing all the branches to remain on the side to which the tree inclines to crook, to give it more weight, and to draw most of the juice or sap that way, and it will naturally incline more to the crook ; at the same time clearing away any other tree on the crooked side, that may be apt, with the wind, to whip the side of the tree to which it inclines to crook. Also taking away such trees of less value as may prevent it from spreading out to the one side more than to the other." He adds, " I have myself tried the experiment with several oak trees at about twelve feet high, that were a little inclined to crook, and that had also a main branch inclined to a horizontal position. In the course of less than twenty years, I had the pleasure of seeing some of these very trees grow so very crooked that the branch would work in with the main stem or body of the tree, to a complete knee or square, which is the most valuable of all trees ; and, as ten trees of crooked oak are required for one straight one, it is of the most essential consequence to have crooked oak trees ; and, besides, an oak tree, properly crooked, that will answer for a large knee (say the main branch, to be fit to work in with the body or trunk of the tree without much waste of wood), is nearly double in value to the same number of feet of a straight tree ; and, indeed, knees of oak are extremely scarce, and difficult to be got."

4002. *Pontey* "knows of no way by which bends of tolerable scantlings (knees excepted) can be produced with certainty and little trouble, but from a side branch kept in a bent position by the branches of another tree or trees overhanging its stem." (*Forest Pruner*, 174.)

4003. *Coppice woods*, in so far as grown from poles or bark, require pruning on the same principle as timber trees, in order to modify the ligneous matter into stem, and produce clean bark. In as far as they are grown for fence wood, fuel, or besom spray, no pruning is required.

4004. *Osier holts* require the laterals to be pinched off the shoots intended for hoops ; those of the basket-maker seldom produce any. The stools, also, require to be kept free from dead wood, and stunted knotted protuberances.

4005. *Hedges* require side pruning, or switching, from their first planting, so as gradually to mould them into "the wedge shape, tapering from bottom to top on both sides equally, till they meet in a point at the top. Two feet at bottom is a sufficient breadth for a five feet hedge ; a greater or less height should have the bottom wider or narrower, accordingly. In dressing young hedges, either of the deciduous or evergreen kinds, the sides only should be cut till the hedge arrives at the proposed height, unless it be necessary, for the sake of shelter, to cut their tops over, in order to make the hedges thicker of branches. Such cutting of the upright shoots, however, is not of any great use in this respect ; because every hawthorn hedge sends out a number of side shoots, which, if encouraged, by keeping the top wedge-shaped as above, will make it abundantly thick." (*Sang*, 447.) In pruning hedges, some use shears ; but the hedge-bill is the most proper instrument, producing a smooth unfractured section, not so apt to throw out a number of small useless shoots which generally follow the crushing cut of the sheers.

4006. *Hedge-row trees* require to be pruned to a tall, clean, erect stem, as at once producing more timber, and doing least injury to the ground under their drip and shade.

4007. *Trees in strips for shelter, or screens for concealment*, ought to be furnished with branches, from the bottom upwards ; unless undergrowth supply this deficiency. Where this is not the case, care should be had that the trees be pruned into conical shapes, so as that the lower branches may be as little as possible excluded from the influence of the weather by the upper ones.

4008. *Trees for shade*, where shelter from winds is not wanting, should be pruned to ample spreading heads with naked stems ; the stem should be of such a height that the sun's rays, at midday, in midsummer, may not fall within some yards of the base of the trunk ; thus leaving under the trees, as well as on their shady side, a space for the repose of men or cattle.

SUBJECT. 5. *Thinning young Plantations.*

4009. *The properly thinning out of plantations*, *Sang* observes, "is a matter of the first importance in their culture. However much attention be paid to the article of pruning, if the plantation be left too thick, it will be inevitably ruined. A circulation of air, neither too great nor too small, is essential to the welfare of the whole. This should not be wanting at any period of the growth of the plantation ; but in cases where it has been prevented by neglect, it should not be admitted all at once, or suddenly. Opening a plantation too much at once, is a sure way to destroy its health and vigour. In thinning, the consideration which should, in all cases predominate, is to cut for the good of the timber left, disregarding the value of the thinnings. For, if we have it in our choice to leave a good, and take away a bad plant or kind, and if it be necessary that one of the two should fall, the only question should be, by leaving which of them shall we do most justice to the laudable intention of raising excellent and full-sized timber for the benefit of ourselves and of posterity ? The worst tree should never be left, but with the view of filling up an accidental vacancy."

4010. *Salmon*, from observations on the most orderly and thriving plantations at Woburn, deduces the following rule for thinning : — "Keep the distance of the trees from each other equal to one-fifth of their height. In the application of this rule for thinning, it is evident that each individual tree can never be made to comply ; for the original distance (even if planted in the most regular order) will allow only of

certain modifications, by taking out every other tree, and so on; but even if the obtaining of such equal distance were practicable, experience would show that another way should be preferred, of which the eye must be the judge, by taking out such trees as are least thriving, stand nearest another good tree, &c. &c.; at the same time keeping in view the rule prescribed. By measuring a chain square, or any quantity of land, and counting the trees thereon; then trying the height of two or three trees in that quarter, and taking one fifth of such for the distance, it would be readily seen how many trees should be contained in the piece measured: or the practice may more simply be regulated by taking the distance of eight or ten trees added together, the average of which should be equal to a fifth of the height of the trees." (*Smith's Mechanics*, vol. ii. p. 358.)

4011. *In thinning mixed plantations*, the removing of the nurses is the first object which generally claims attention. This, however, should be cautiously performed; otherwise the intention of nursing might, after all, be thwarted. If the situation be much exposed, it will be prudent to retain more nurses, although the plantation itself be rather crowded, than where the situation is sheltered. In no cases, however, should the nurses be suffered to overtop or whip the plants intended for a timber crop; and for this reason, in bleak situations, and when perhaps particular nurse plants can hardly be spared, it may be sometimes necessary to prune off the branches from one side entirely. At subsequent thinnings, such pruned or disfigured plants are first to be removed; and then those which, from their situation, may best be dispensed with.

4012. *At what period of the age of the plantation the nurses are to be removed*, cannot easily be determined; and, indeed, if the nurses chiefly consist of larches, it may with propriety be said, that they should never be totally removed, while any of the other kinds remain. For, besides that this plant is admirably calculated to compose part of a beautiful mixture, it is excelled by few kinds, perhaps by none, as a timber tree. But when the nurses consist of inferior kinds, such as the mountain ash or Scots pine, they should generally be all moved by the time the plantation arrives at the height of fifteen or twenty feet, in order that the timber trees may not, by their means, be drawn up too weak and slender.

4013. *Before this time it may probably be necessary to thin out a part of the other kinds*. The least valuable, and the least thriving plants, should first be condemned, provided their removal occasion no blank or chasm; but where this would happen, they should be allowed to stand till the next or other subsequent revision.

4014. *At what distance of time this revision should take place* cannot easily be determined; as the matter must very much depend on the circumstances of soil, shelter, and the state of health the plants may be in. In general the third season after will be soon enough; and if the plantation be from thirty to forty years old, and in a thriving state, it will require to be revised again, in most cases within seven years. But one invariable rule ought to prevail in all cases, and in all situations, to allow no plant to overtop or whip another. Respect should be had to the distance of the tops, not to the distance of the roots, of the trees: for some kinds require more head room than others; and all trees do not rise perpendicular to their roots, even on the most level or sheltered ground.

4015. *With respect to the final distance to which trees, standing in a mixed plantation, should be thinned*, it is hardly possible to prescribe fixed rules; circumstances of health, vigour, the spreading nature of the tree, and the like, must determine. Whether the trees are to be suffered to stand till full grown, which of the kinds the soil seems best fitted for; whether the ground be flat or elevated; and whether the situation is exposed or sheltered, are all circumstances which must influence the determination of the ultimate distance at which the trees are to stand. It may, however, be said, in general, that if trees be allowed a certain distance, of from twenty-five to thirty feet, according to their kinds and manner of growth, they will have room to become larger timber.

4016. *Pontey* shows, that forty feet distances are necessary (or only about twenty-seven to the acre) to the unassisted growth of large oak trees, owing to the flat, spreading, and close form of their heads; but that the properly trained, open, high, and conical heads of such trees will admit of their standing at twenty-five feet distances, or about seventy trees on the acre, and of the most profitable kind. What an inducement to pruning and management! (*Farey's Derbyshire*, vol. i. p. 289.)

4017. *Plantations of Scots pine*, if the plants have been put in at three, or three and a half, feet apart, will require little care until the trees be ten or twelve feet high. It is necessary to keep such plantations thick in the early part of their growth, in order that the trees may tower the faster, and push fewer and weaker side branches. Indeed, a pine and a soft wood plantation should be kept thicker at any period of its growth, than plantations consisting of hard wood and nurses already mentioned; and it may sometimes be proper to prune up certain nurse plants, as hinted at above (4011.), for nurses in a mixed plantation. Those pruned-up trees are of course to be reckoned temporary plants, and are afterwards to be the first thinned out; next to these, all plants which have lost their leaders by accident, should be condemned; because such will never regain them so far as afterwards to become stately timber; provided that the removal of these mutilated trees cause no material blank in the plantation. Care should be taken to prevent whipping; nor should the plantation be thinned too much at one time, lest havock be made by prevailing winds; an evil which many, through inadvertency, have thus incurred. This precaution seems the more necessary, inasmuch as Scots pines, intended for useful large timber, are presumed never to be planted except in exposed situations and thin soils. At forty years of age, a good medium distance for the trees may be about fifteen feet every way. It may be worthy of remark, that after a certain period, perhaps by the time that the plantation arrives at the age of fifty or sixty years, it will be proper to thin more freely, in order to harden the timber; and that then this may be done with less risk of danger, from the strength the trees will have acquired, than at an earlier period; but still it should be done gradually.

4018. *Plantations of spruce and silver firs*, intended for large useful timber, should be kept much in the manner above stated, both in their infancy and middle age. As already remarked, planting and keeping them as thick as is consistent with their health are the best means of producing tall, straight, clean stems, and valuable timber. When planted for screens or for ornament, they require a different treatment. "To larch

plantations, the above observations will also apply, and indeed they are applicable to plantations of all kinds of resinous trees.

4019. *The exposed margin of all young plantations* should be kept thicker than the interior. The extent to which this rule should be carried must be regulated according to the degree of exposure of the situation, the age of the plants, the tenderness of the kinds, and other circumstances."

4020. *The proper season for thinning* is autumn, or very early in the spring, where the trees are to be taken up by the root and replanted elsewhere; winter for thinning for timber and fuel: but such trees as are valuable for their barks should be left untouched till the sap rises in April or May.

4021. *Copse-woods* require thinning when young, like other plantations, and when once established the stools require to be gone over the second year after cutting, and all superfluous suckers and shoots removed. This operation should be repeated annually, or every two or three years, in connection with pruning, till within three or four years of the general fall of the crop.

SECT. VI. *Improvement of Neglected Plantations.*

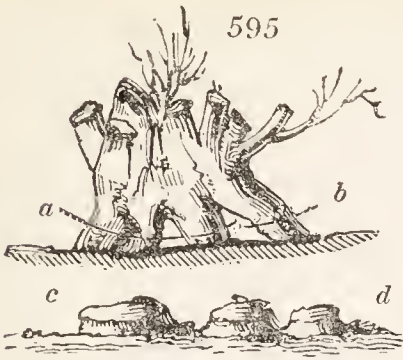
4022. *Neglected and mismanaged plantations* will include the greater number in Britain. The artificial strips and masses have generally never been thinned or pruned; and the natural woods, or copse-woods, have for the most part been improperly thinned or cut over. It is often a difficult matter to know what to make of such cases, and always a work of considerable time. "Trees," Sang observes, "however hardy their natures may be, which have been reared in a thick plantation, and consequently have been very much sheltered, have their natures so far changed, that, if they be suddenly exposed to a circulation of air, which, under different circumstances, would have been salubrious and useful to them, they will become sickly and die. Hence the necessity of admitting the air to circulate freely among trees in a thick plantation, only gradually, and with great caution." This precaution is particularly necessary in thinning plantations of Scotch pine. Trees which have been screened by each other for forty or fifty years, cannot bear the loss of their near neighbours.

4023. *A plantation which has become close and crowded*, having been neglected from the time of planting till perhaps its twentieth year, should only have some of the smallest and most unsightly plants removed; one, perhaps in every six or eight, in the first season; in the following season, a like number may be removed; and in two or three years afterwards, it should be gone over again; and so on till it be sufficiently thinned. It will be proper to commence the thinning at the interior of the plantations, leaving the skirts thicker till the last; indeed, the thinning of the skirts of such a plantation should be protracted to a great length of time. With thinning, pruning to a certain extent should also be carried on. "If the plantation," Sang observes, "consists of pines and firs, all the rotten stumps, decayed branches, and the like, must be cut off close by the bole. It will be needful, however, to be cautious not to inflict too many wounds upon the tree in one season; the removing of these, therefore, should be the work of two or three years, rather than endanger the health of the plantation. After the removal of these from the boles of the firs and larches, proceed every two or three years, but with a sparing hand, to displace one or perhaps two tiers of the lowermost live branches, as circumstances may direct, being careful to cut close by the trunk, as above noticed. In a plantation of hard wood, under the above circumstances, the trees left for the ultimate crop are not to be pruned so much at first as might otherwise be required; only one or two of their competing branches are to be taken away, and even these with caution. If it be judged too much for the first operation to remove them entirely, they may be shortened, to prevent the progress of the competition; and the remaining parts may be removed in the following season; at which time, as before observed, they must be cut close by the bole. (*Plant. Kal.* 467.) We cannot agree to that part of these directions which respects the removal of "perhaps two tiers of the lowermost live branches;" but, paying great deference to the opinion of Mr. Sang, we have judged it right, in a work of this nature, to lay it before our readers, and allow them to judge for themselves.

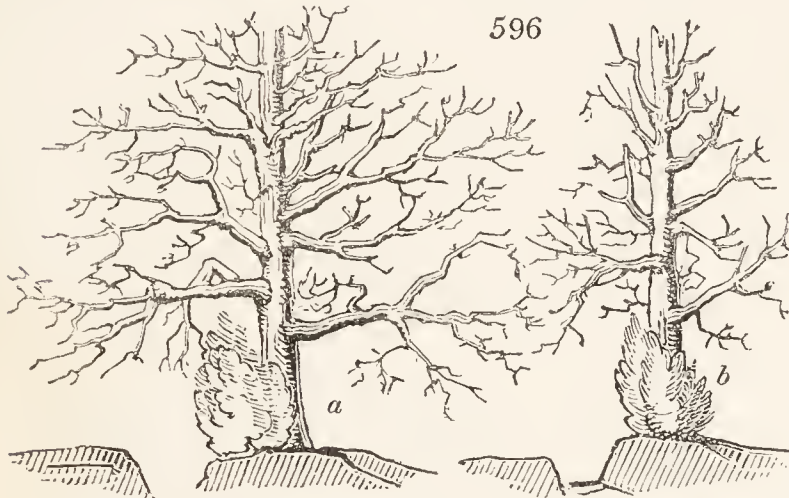
4024. *The operation of thinning and pruning, thickening or filling up*, or renewing portions that cannot be profitably recovered, should thus go on, year after year, as appearances may direct, on the general principles of tree culture; and for this purpose, the attentive observation and reflection of a judicious manager will be worth more than directions which must be given with so much latitude.

4025. *Pontcy has noticed various errors in Kennedy's Treatise on Planting*, and even in Sang's *Kalendar*, on the simple subject of distances, which have originated in their giving directions for anticipated cases which had never come within their experience. "Most people," he says, "take it for granted, that if trees stand three feet apart, they have only to take out the half to make the distances six feet, though, to do that, they must take down three times as many as they leave. By the same rule, most people would suppose that twelve feet distance was only the double of six; but the square of the latter is only thirty-six, while that of the former is one hundred and forty-four, or four times the latter; so that, to bring six feet distances to twelve, three trees must be removed for every one left." (*Profitable Planter*, 256; and *Forest Pruner*, 21.)

4026. *Copse-woods are sometimes improved by turning them into woods, which requires nothing more than a judicious selection and reservation of the strongest of those shoots which proceed from the stools, and which spring more immediately from the collar. But a greater improvement of copse-woods consists in cutting over the overgrown and protuberant stools by the surface of the soil (fig. 595. a, b, c, d), which has been found by Monteith completely to regenerate them. The operation is performed with a saw, in a slanting direction, and the young shoots, being properly thinned and pruned, soon establish themselves securely on the circumference of large and perhaps rotten-hearted roots. (Forester's Guide, 60.)*



4027. *Neglected hedge-row timber may be improved by pruning according to its age. Blaikie recommends what he calls foreshortening, or cutting-in, as the best method*



both for young and old hedge-row timber. "This operation is performed by shortening the overluxuriant side-branches (fig. 596. a), but not to cut them to a stump, as in snag-pruning; on the contrary, the extremity only of the branch should be cut off, and the amputation effected immediately above where an auxiliary side-shoot springs from the branch on which the operation is to be performed (b); this may be at the distance of two, four, or any other number of feet from the stem of

the tree; and suppose the auxiliary branch which is left (when the top of the branch is cut off) is also over-luxuriant, or looks unsightly, it should also be shortened at its sub-auxiliary branch, in the same manner as before described. The branches of trees, pruned in this manner, are always kept within due bounds; they do not extend over the adjoining land, to the injury of the occupier, at least not until the stem of the tree rises to a height (out of the reach of pruning), when the top branches can do comparatively little injury to the land. By adopting this system of pruning, the bad effects of close pruning on old trees, and snag-pruning on young ones, will be avoided, the country will be ornamented, and the community at large, as well as individuals, benefited."

SECT. VII. *Treatment of Injured and Diseased Trees.*

4028. *With respect to wounds, bruises, casualties, and defects of trees, such small wounds as are required to be made by judicious pruning, easily heal up of themselves; large wounds, by amputation of branches above six inches in diameter, should, if possible, never be made. Even wounds of six inches diameter or under will heal more quickly by the application of any material that excludes the air and preserves the wood from corruption; and we agree with Sang in recommending coal-tar, or the liquor produced from coals in manufacturing gas. It is, however, less favourable to the progress of the bark over the wound than a coating of clay or cow-dung covered with moss to keep it moist. Pontey recommends putty and two coats of paint over it. In case the wood, at a bruised or amputated place, has by neglect become already corrupted, the rotten or dead wood is to be pared out quite into the quick, and the wound is then to be dressed with tar or clay, covered with a piece of mat, sacking, or moss. A wound, hollowed out as above, may at first appear an unsightly blemish; but, in subsequent years, nature will lay the coats of wood under the new-formed bark thicker at that place; and probably may, in time, fill it up to be even with the general surface of the tree.*

4029. *All fractures, by whatever means produced, are to be managed as the circumstances of the case require. If a large branch be broken over at the middle of its length, it should be sawn clear off close by the lateral which is nearest to the bole of the tree: but if there is no lateral, or branch capable to carry forward the growth, cut the main or fractured branch in quite to the bole. In both cases, treat the wound as above recommended.*

4030. *Interior rotting, arising from the dampness of the soil, cannot, by the art of man, be cured; though it might have been prevented by timely draining. The hearts of trees frequently rot, where there is no excess of moisture, and especially of such as have been produced from old roots left in the ground by a previous felling. Such roots, when in good ground, send up very great shoots, with few leaves in proportion to their size; from*

the absence of a profusion of these, properly to concoct the juices so abundantly supplied by the roots, the fibre of the wood is loose and imperfect; the next season will produce more leaves in proportion to the supply of juices, yet not a sufficient number for making timber; several years may pass before this event will arrive: this crude and ill-digested timber, disposed to premature decay, is the foundation over which subsequent coatings of wood are laid: yet, however perfect these may be, they do not prevent the progress of decomposition going on in the interior. Nature thus teaches how necessary numerous leaves are to the preparation of the solid wood: the cotyledons and subsequent leaves of a one-year old tree are a thousand times greater, compared with its solid contents, than are the leaves to the solid contents of the first year's shoots from roots like the above. *Sang.*

4031. *Shakes* often arise from the weight and multiplicity of top branches, and might have been prevented by timely pruning. Shakes or rents in the boles of trees, however, often happen where there is no excess of tops. Sometimes the rain, running down from the branches, wets one part of the bole, while the rest is comparatively dry. If this circumstance is succeeded by an intense frost, before the wetted side becomes dry, the bole may be rent for a length, and perhaps to the depth of the core. Shakes or rents, like the above, are difficult to cure. The best method of helping them is to trace out their upper extremity, caulk it up with oakum, and pitch it over, to prevent the rain descending that way in future. (*Sang.*)

4032. *In cases of hollowness*, Pontey recommends probing to the bottom, letting out the water, if any, with an auger, drying the cavity with a cloth, filling it with dry sand, plugging it with wood and oakum, and then painting it over.

4033. *Stems or branches decorticated* by lightning or otherwise, if the soft wood is not much injured, will heal over and become covered with bark; and this the more certainly and rapidly if the air be excluded by a coating of adhesive matter, as cow-dung and quicklime, or by tying on moss or bandages of mat or cloth. Pontey gives an instance in which such treatment was successful in the case of an apple tree. (*Pruner*, 230.) We have witnessed it on an extensive scale on the trunk of a pear tree; and we are informed, on the best authority, of other cases now under progress, in the government garden of the Luxembourg, at Paris.

4034. *Withered or decayed tops* may arise from age and incipient decay; but also, as Pontey states, from improper pruning, or the want of it. We often see it from the improper pruning of elms, which, after having been close pruned to their summits for many years, are left entirely to nature; in that case they branch out luxuriantly below, and the top withers. By neglecting to thin out the branches on the stems of non-resinous trees the same effect may be produced.

4035. *Stunted bushy tops*, on very tall naked stems, show a deficiency of nourishment, from these circumstances; and those on short stems from defects of the soil. Obliquely placed misshapen heads, in detached trees, commonly proceed from the same causes and from want of shelter. Stunted growth, both in tops and stems, is also produced by ivy, and by lichens, mosses, mistletoe, and other parasites. Ivy compresses the bark, and precludes its expansion, as well as excludes air and moisture, by which the outer bark becomes rigid and corky.—Happily, both men and trees will live a long time under the influence both of deformity and disease.

4036. *Excessive exudations of gum and resins* are peculiar to resinous and some other trees when over-pruned, or pruned at improper times. Mildew, honeydew, and blight, three popular names applied to the effects of certain insects of the Aphis kind, attack the oak, beech, poplar, and many trees: all that can be said is, if proper regimen has been regularly attended to, trees will overcome these and all other enemies.

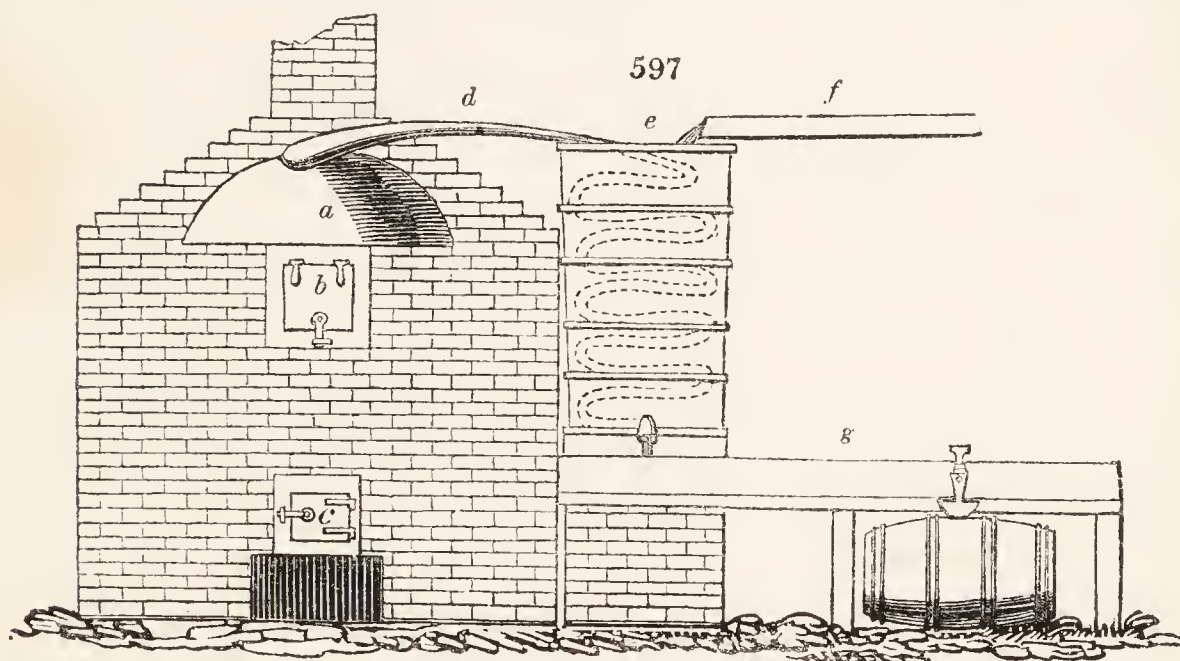
4037. *Insects and vermin*. Almost every tree has its particular insect of the Hemipterous and Dipterous families, and many of the Coleoptera are common to all. The foliage of the small-leaved elm of hedges is often almost entirely destroyed in the early part of the season by *Tenthredinidæ*; and those of the larch and Scotch pine have suffered materially in some seasons from aphides. The Aphis laricea L. (*Eriosoma* of Leach) increased to an alarming extent, from 1800 to 1802, on the larch, on account of three dry seasons following each other; but, though it retarded their growth, it ultimately destroyed very few trees. Sang says, he has known it since 1785; that it dirties more than injures the tree, and is now (1819) thought little of. Indeed, almost every species of tree has been known to have suffered in some one season or more, and in particular districts, from insects; for which, on so large a scale, there seems to be no applicable remedy, but patiently waiting till their excess, or the increase of other vermin their natural enemies, or a change of seasons, causes them to disappear. Trees properly cultivated and managed generally overcome such enemies. The hare is well known to be injurious to young trees, and especially to laburnums, by gnawing off their bark. Coating their stems with dung and urine, fresh from the cow-house, is said to be an effectual remedy. It may be put on with a brush to the height of two feet; a barrow-load will suffice for a hundred

trees, with stems of three or four inches in diameter; and its virtue, after being laid on, endures at least two years. (*Bull. in Cald. Hort. Mem. iv. 190.*)

SECT. VIII. *Products of Trees, and their Preparation for Use or Sale.*

4038. *The ordinary products of trees* made use of in the arts are leaves, prunings or spray, thinnings, seeds, flexible shoots, bark, branches, roots, and trunks. Trees also afford sap for wine and sugar, and extract for dyeing; but these products are of too accidental or refined a nature for our present purpose.

4039. *The brush-wood or spray of trees* may be turned into charcoal, substituted for thatch in roofing cottages, used as common fuel, formed into fences, or distilled for pyrolignous acid. Some sorts, also, as the spray of the oak, the willow, the birch, the mountain ash, and others, may be used in tanning. In a green state with the leaves on, the spray of the elm, the poplar, the lime, and others, may be used in feeding cattle; or the spray may be dried like hay, and stacked for that purpose, as in Sweden; or it may be rotted for manure. The spray of all trees not resinous may be used in the distillation of pyrolignous acid. This acid is much used in calico-printing works; and, according to Monteith, sold in 1819, in the neighbourhood of Glasgow, at from 1*l.* 2*s.* to 1*l.* 10*s.* per ton. The distillation is carried on in a cast or malleable iron boiler (*fig. 597.*), which should be from five to seven feet long, three feet wide, and



say four feet deep from the top of the arch, built with fire-brick. The wood is split or round, not more than three inches square in thickness, and of any length, so as to go into the boiler at the door. When full, the boiler door (*b*) is properly secured, to keep in the steam; then the fire is put to it in the furnace below, and the liquid comes off in the pipe above (*d*), which is condensed in a worm, in a stand (*e*) filled with cold water, by a spout (*f*), and empties itself, first into a gutter below (*g*), and from that it is let into barrels, or any other vessel; and thus the liquid is prepared. One English ton weight of any wood, or refuse of oak, will make upwards of eighty gallons of the liquid. There is also a quantity of tar extracted, which may be useful in ship-building. (*Gard. Mag. vol. ii.*)

4040. *The thinnings*, when not beyond a suitable age, and taken up properly, and at a proper season, may be planted in other situations, or as single trees and groups; or they may be used as hoops, hop-poles, poles for garden training, for fencing, for props in collieries; and for a great variety of purposes; those of which the bark is useful for tanning should not be cut down or rooted up till May, but the others at any time during winter. It is common to sort them into lots, according to their kind or size; and to faggot up the spray for fuel, besom stuff, or for distilling for bleachers' liquid.

4041. *The seeds of trees* in general cannot be considered of much use beyond that of continuing the species. The seeds of the oak, beech, and sweet chestnut, however, are valuable for feeding swine, and where they abound may either be swept together after they drop, and carried away and preserved dry in lofts or cellars for that purpose; or, if other circumstances are favourable, swine may be driven under the trees to collect them. These and other seeds, as the haw and holly, are eaten by deer. The seeds of the trees mentioned, and of all the resinous tribe, are in general demand by the nurserymen, for the purposes of propagation; and the seeds of almost all other trees and shrubs are in limited or occasional demand: they may also be collected for private sowing. Tree seeds generally ripen late in the season, and are to be collected in the end of autumn or

beginning of winter, with the exception of a few, such as the elm, poplar, willow, and one or two others, which ripen their seeds in May and June.

4042. *In osier grounds*, willows produce flexible shoots, and, whether intended for the basket-maker or cooper, should not be cut till the second season after planting, in order to strengthen the stools: but by the third autumn the crop will be fit for the basket-maker; and in the fourth, plantations intended for the cooper (hoops requiring the growth of two years) will be ready. The seasons for cutting are November and March; after the former period the wounds are apt to be injured by frost, and after the latter the sap is too far advanced; some is lost by bleeding, and the buds are developed too suddenly to admit of proper strength in the shoots. The cut should be made within three buds of the point whence the shoot issued, in a sloping direction, and the section on the underside. In cutting hoop-willows, the swell at the bottom of the shoot only should be left, that being furnished with abundance of buds for future growth. After being cut, the hoops are trimmed from any side-shoots, and tied up in bundles of a hundred, of six scores each, which, in 1820, sold for from four shillings to five shillings a bundle. The willows are sorted into three sizes and tied in bundles two feet in circumference, within a foot of the lower ends. When to be peeled, they are immediately after cutting set on their thick ends in standing water, a few inches deep, and there they remain till the sap ascends freely, which is commonly by the end of the succeeding May. "The apparatus for peeling is simply two round rods of iron, nearly half an inch thick, sixteen inches long, and tapering a little upwards, welded together at the one end which is sharpened, so as that it may be easily thrust down into the ground. When thus placed in a piece of firm ground, the peeler sits down opposite to it, and takes the willow in the right hand by the small end, and puts a foot or more of the great end into the instrument, the prongs of which he presses together with the left hand, and with the right draws the willow towards him; by which operation the bark will at once be separated from the wood: the small end is then treated in the same manner, and the peeling is completed. Good willows, peeled in the above manner, have been sold, for some seasons past, at from six shillings and sixpence to seven shillings the bundle of four feet in circumference. After being peeled, they will keep in good condition for a long time, till a proper market be found."

4043. *Copse-woods* are generally cut over when the shoots of the stools have attained from three to five inches' diameter at their bases; some grown chiefly for hop-poles, and ware or stuff for crates, hampers, or wattled hurdles, are cut over earlier; and others, where small timber for fencing and other country purposes is wanted, are left later. In some parts of Herefordshire, where the oak grows with great rapidity, copse-woods are cut over every twelve years; in the highlands of Scotland, where it grows much more slowly, the time varies from twenty to twenty-five or thirty years. "The bark is there considered as having arrived at its utmost perfection and at its highest value, at the age of between twenty and thirty years: under that age, its virtues are weak; above it, the bark becomes coarse, and loses its sap. Another important reason for cutting down oak coppice-wood about the above period is suggested in the *Stirlingshire Report*, p. 218.; namely, 'that it is a fact established by experience, that it will not renew itself, if it remains uncut beyond the space of about forty years.' " (*Gen. Rep. of Scotland*, 218.) Where there is a considerable tract of copse-wood, it is common to divide it into portions, in number according to the period of cutting. These are to be cut in rotation, so that, when the last portion is cut over, the first is again ready for cutting.

4044. *The seasons for cutting* the kinds of trees whose barks are not made use of, are winter and early in spring; but the oak and other trees which are peeled, are left till the middle of April or May. Birch and larch woods will peel nearly a month earlier than the oak. Should there be no frost, birch and larch may be peeled about the beginning of April; but the birch is commonly allowed to stand till July, and the peeling of it is commenced after that of the oak has been completed. The reason is, there is an outer skin upon birch-bark which requires to be taken off, as it is of no use to the tanner, and renders that part which is of use more difficult to be ground; the month of July is the only time at which the two barks can be separated with ease, as at this time the juice or sap has made its circulation through the tree and bark, and this circumstance renders the separation more easy. From the beginning of May to the middle of July is the usual time for barking the oak. The earlier in the spring this operation is performed on the oak, both for the growth of a natural wood, and for the bark, the better. When the sap has begun to rise, the bark will easily be detached from the wood, and it ought then to be taken off without loss of time; and, if the whole could be taken off before the leaf is completely developed, the bark would be better. After the sap has arisen to the leaf and new growth, the bark becomes more dry, and requires more beating to separate it from the wood: and when what is called the black sap is descending the tree, the bark taken off is black, and loses its original colour; at this time also the bark begins to throw off a scurf, more especially young bark without much cork on it; this outer skin having less of the proper sap or juice, and being much drier when taken off, will weigh less, and consequently will not be so valuable. If possible, oaks should be barked by the middle of June, as every ton of bark taken off after the first of July will be deficient two cwt. per ton, compared with the same quantity taken off in May or early in June.

4045. *The termination of cutting* is generally fixed for the fifteenth day of July, and after this date there should not be a single stool of oak wood cut that is intended for the growth; and as soon as possible after the fifteenth, the whole of the wood and bark should be carried away, that the young growths may not be disturbed or injured, as at this time they will have made considerable progress; at any rate, there should neither be wood nor bark remaining within the new cut hag after the first of August,

nor should either horse or cart be permitted to enter it after that period; for, after the beginning of August, oaks make what is termed a Lammas growth, and the future prosperity and health of the coppice in a great measure depend on the first year's growth, as far as regards form and vigour of the shoots. (*Forester's Guide*, 69.)

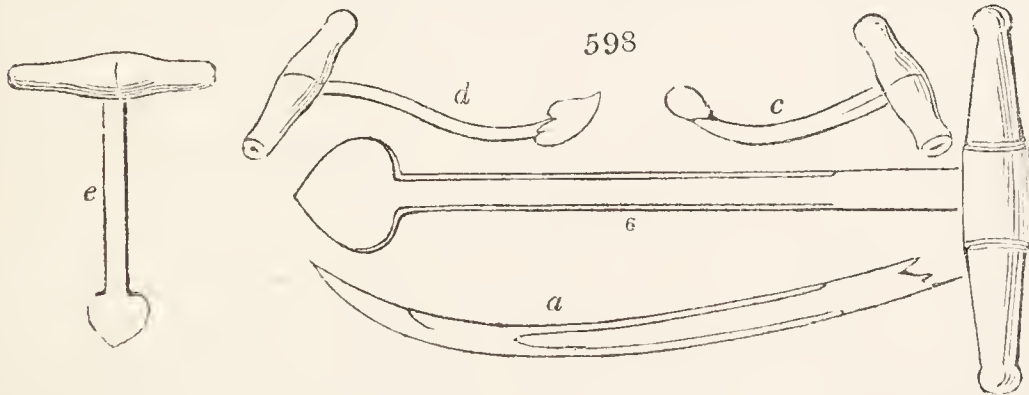
4046. *The best mode of cutting* is evidently that of using a saw, and cutting the shoots over in a slanting direction close by the surface. When the stool, after having been cut several times, has acquired considerable diameter, it is customary in the midland counties, Marshal states, to hollow it out in the centre, from a notion that, by rotting away the central roots, the circumferential stems will grow more vigorously, and become as it were separate plants. This is in fact the case in very old copses. For several cuttings, however, it must evidently be the safer policy to keep the stool highest in the middle to throw off the rain, and preserve it sound.

4047. *Monteith* says, "It will be found, upon experiment, perfectly evident, that stools dressed down to the surface of the ground (taking care always not to loosen the bark from the root, or allow it to be peeled off in the smallest degree below the earth, but rounded down level to it) will send forth the most vigorous shoots, and stand the weather, and be the stoutest and best throughout the age of the coppice." (*Forester's Guide*, 61.) From the late season at which the trees to be barked are generally cut, they often receive considerable injury, both from that circumstance, and the manner in which the operation is performed. Monteith appears to us to have furnished the best directions for executing the work in a safe manner. He first sends a person furnished with an instrument with a sharp cutting edge (*fig. 598. a*) through the copse, whose business is, "to trample down the long grass or foggage all round the root, and then to make a circular incision into the bark so deep as to reach the wood, at about an inch above the surface of the earth: thus the bark when taken off, will injure no part of that which is below the circular incision."

4048. *The root of the tree being thus prepared*, the cutters ought to proceed to their part of the work, not with an axe, however, as is most generally recommended, but with a saw; because, in cutting with the axe, unless the root of the tree be so small in diameter as to be severed in one or two strokes at most, the axe loosens the root to such a degree, that it not only loses the present year's growth, but often fails altogether to grow. Therefore, if the diameter of the root be six inches, or upwards, it should always be cut with a cross-cut saw, entering the saw about half an inch above where the circular incision has been made into the bark, if a small tree; but if the tree be ten or twelve, or more inches in diameter, the saw ought to be entered two inches above it.

4049. *There are two advantages to be derived from cutting with the saw*: it has no tendency to loosen the root of the tree, but leaves it in such a condition as to be more easily and properly dressed; it also saves a portion of the wood that would otherwise be destroyed by the axe. On no pretence should oaks of six inches' diameter be cut with an axe, but always with a saw. Having cut through the tree with a saw, take a sharp adze, and round the edges of the stool or root, going close down to the surface of the earth, taking with the adze both bark and wood, sloping it up towards the centre of the stool, taking particular care always that the bark and wood both slope alike, as if they formed one solid body, being sure always that the bark be not detached from the root. An objection has been made to this mode of cutting with the saw, as taking up too much time; but I have found that two men with a cross-cut saw, kept in good order, will cut as much as two men will with an axe. (*Forester's Guide*, 58.)

4050. *In the operation of barking trees*, "the barkers are each furnished with light short-handed mallets, made of hard wood, about eight or nine inches long, three inches square at the face, and the other end sharpened like a wedge, in order the more easily to make an incision in the bark, which is done all along the side of the tree which happens to be uppermost, in a straight line: and as two barkers are generally employed at one tree, it is proper, that whilst the one is employed in making an incision with the mallet, as above, the other being furnished with the barking-bill (*fig. 598. a*), cuts the bark



across the tree, in lengths of from two feet six inches to three feet. Having thus made the incision in the bark, both ways, the barkers being also each furnished with peeling irons of different sorts (*b, c, d, e*); if the tree or piece of timber to be barked is such as the two barkers can easily lift one end of it,

this is placed on two pieces of wood three feet long, and called horses; these are about the thickness of a paling-stake, and have a forked end on each about six inches long, the other end being sharpened to go into the ground; two of these horses are placed in a triangular form against one another, one end of the piece to be peeled being raised on the horses, the two barkers standing opposite to each other, and entering the peeling-irons into the incision made by the mallet, and pressing the iron downwards between the bark and the timber. In this way it will be found very easy to take the bark off in one whole piece round the tree; and, if possible, let these pieces be as long as the incisions made in the bark. In some cases, where there is not much sap, the bark may require a little beating with the square end of the mallet, to cause it to separate easily from the wood; but the less beating with the mallet the better, as it has a tendency to blacken the bark in the inside or fleshy part of it, so that, when the tanner sees it, he supposes it to be damaged, and undervalues it. The branches of the tree being previously all lopped off with the axe, the persons, in number according to the extent of the work, with the bill smooth all the branches, cutting them in lengths of from two feet six inches to three feet, down as small as one inch in circumference. The barkers, principally women, are each provided with a smooth hard stone of about six or eight pounds' weight, beside which they sit down, and having collected a quantity of saplings, branches, or twigs, they hold the piece on the stone with one hand, and with the mallet in the other, they beat it till the bark be split from the wood, from the one end to the other, and taking it off all the length of the piece, if possible, then lay it regularly aside, till a bundle of considerable size is formed."

4051. *Drying the bark*. The point most particularly to be observed in this art is, putting the bark up to dry; which is done by setting it upon what are called the lofts or ranges. These are erected by taking forked pieces of the loppings, called horses, the one three feet long, the other two feet six inches, and driving them about four inches into the ground, opposite one another, about two feet asunder in the breadth, and as much betwixt them lengthways as will admit long small pieces of wood to be put upon them, and as many of these must be put together as will hold the bark of every day's peeling. These ought to be erected in as dry and elevated a spot as can be found in the margin of the wood, or better on its outside. The bark being carried and laid on this loft, with the thick ends of it all laid to the high side of the range, and the small bark laid on to the thickness of about six inches; and the bark taken off the largest of the wood laid regularly on the top, which serves for a covering, and the lofts or ranges having a declivity of about six inches, the rain will run off them readily, and if properly put up in this manner, they will keep out a great deal of rain. After it has lain in this state for three days, if the weather is good

and dry, it ought to be all turned over, and the small bark spread out, so as not to allow it to sit together, which, if much pressed, it is apt to do; and if it does so with the natural sap in it, it has a chance of moulding, which is extremely hurtful to the bark, and both lessens it in weight and in value. After the bark has stood on the ranges about eight or ten days, if the weather be good, it may either be put into a house or a shed, or if intended to be put up into a stack it may now be done. A stack of bark ought never to exceed eight feet in width, and twelve or fifteen feet in height, raised in the middle like a haystack. If it is to stand any length of time in the stack, it ought to be thatched, and in that state may remain all winter. The greatest care ought to be taken to preserve the colour of the inner parts of the bark, because the colour of it is generally looked to as a principal criterion of its value. Before being put into the stack, the natural sap ought to be dried out of it, in order to prevent its fermenting; because, if a fermentation takes place in one part of the stack, it generally goes through and spoils the whole. The same mode of treatment will do for all kinds of bark as well as the oak: but the birch has an outer or shreddy skin upon it, that is rejected by the tanner, and, as already observed, must be peeled off.

4052. *Chopping the bark.* "When the bark is ready for the tanner, it has to undergo the work of chopping, which is done by driving in two or more stakes into the ground, with a fork on the upper end of each, leaving them about two feet six inches from the ground, and laying a long small piece of wood across between the two, where a number of people stand, and the bark is carried and laid down behind them, which they take up in their hands and lay on the cross tree, and then, with a sharp whittle or bill in the other hand, they cut it into small pieces, about three inches in length: when this is done, it is trampled into bags, which hold about two hundred weight each, and in these bags it is weighed when sold by the ton, in tons, hundred weights, quarters, and pounds, and in the above manner delivered to the merchant or tanner." (*Forester's Guide*, 199.)

4053. *The disbarked timber* is prepared for sale by being sorted into straight poles of the largest size, stakes and other pieces fit for palings, faggots, fuel, &c. The unbarked wood is similarly sorted, and affords, where there is much hazel or ash, cord wood or bundles of clean shoots for making packing crates, hampers, &c., poles for hops, larger poles for fences, rails, paling-stakes, stakes and shoots for hurdles, besom stuff, spray for distillation, and a variety of other objects, according to the local demand, or the opportunity of supplying a distant market by land-carriage. The brush or spray of non-resinous trees is called in some places ton-wood, and is used for distilling the pyrolignous acid used in bleachfields and calico print-works. "When wood of this description is sent to Glasgow, where there are extensive works for the purpose of distilling it, it sells readily at from 1*l.* 2*s.* to 1*l.* 10*s.* per ton; but when there are large cuttings, particularly of young woods, it is worth while to erect boilers near the wood to distil it, as these boilers can be erected at no great expense, and in this case the liquid is easily carried in casks to where it is consumed, at less expense than the rough timber could be; of course it will pay much better. Small wood of this description is also used for charcoal: but in distilling it, there is part of it made into charcoal, which will supply the demand of that article, so that it is by far the most profitable way, when there is any great quantity to dispose of, to erect boilers and distil it; unless where the local situation of the wood will admit of its being shipped at a small expense, and carried to where the works mentioned are carried on. All kinds of non-resinous woods will give the extract in question; but oak, ash, Spanish chestnut, and birch, are the best." (*Forester's Guide*, 155.) Where the oak grows slowly, as in the Highlands, the but-ends of the poles are used for spokes for chaise wheels. "Long spokes are from thirty to thirty-two inches long by three inches and a half broad, and one inch and a half thick, and the short ones for the same purpose, from twenty-two to twenty-four inches long, and the same sizes otherwise. Cart-wheel spokes, from twenty-six to twenty-eight inches long, four inches broad by two inches thick. These are the sizes they require to stand when rough blocked from the axe. Small wood, when sold for this purpose, brought, in 1820, 2*s.* a cubic foot, measured down to three inches square." (*Monteith*.)

4054. *In some cases copse-woods are sown with grass-seeds, and pastured* by sheep, horses, and cattle. Some admit the animals the fifth year after the last cutting; others, not till the eighth: but Monteith thinks this should never be done till the fifteenth year. If the ground is properly covered with trees, it can seldom be advantageous to admit any species of stock, unless during a month or two in winter.

4055. *Pollard-trees*, which may be considered in most cases as injurious deformities, are lopped at stated periods like copse-woods; and the lop, whether to be barked or otherwise, is to be treated in all respects like that of copse.

4056. *The period at which trees are felled*, for the sake of their timber, is determined by various causes. By maturity of growth, or where the annual increase is so trifling as to render their standing no longer worth while in point of profit; when wanted for private use or sale; or when defects in the tree, or new arrangements in its situation, point out the necessity of its removal. "A timbered estate," Marshal observes, "should frequently be gone over by some person of judgment; who, let the price and demand for timber be what they may, ought to mark every tree which wears the appearance of decay. If the demand be brisk, and the price high, he ought to go two steps farther, and mark not only such as are full-grown, but such also as are near perfection." In trees, as in the human species, there are three stages, youth, manhood, and old age. In the period of youth, the growth is rapid; in manhood, that growth is matured; and in old age, it begins to decay.

4057. *The most profitable season for felling timber* is at what may thus be termed the beginning of manhood. After that time, though the tree may appear sound and healthy, its annual increase is so little, that it would be more profitable to cut it down and replant. The number of years that a tree may stand, before it arrives at this period, must vary in different soils and situations; but the period itself may easily be ascertained by the annual shoots, the state of the bark, and by taking the circumference of the tree at the same place for two or three successive seasons, and comparing the difference. In the view of profiting from timber produce, it is of great consequence to cut down plantations at maturity. Many trees will stand half, others a whole century, after they are full-grown, appear quite healthy, and at the same time make little or no increase of timber. But there are particular cases, arising from the nature and state of the markets, where it may even be more profitable to cut timber before it is arrived at a full growth. (*Treat. on Countr. Res.* ii. 577.)

4058. *Preparations for felling.* It has been strongly recommended to disbark trees a year or more before they are taken down, in consequence of the result of certain experiments commenced by Buffon in 1737. In May of that year, he disbarked three oak trees, forty feet in height, where they stood. In the course of three years they died, and, on cutting them down, the outer wood was found hard and dry, and the internal wood moist and softer. After trying its strength, &c., he concludes that "timber which has been disbarked and dried while standing, will weigh heavier, and prove stronger, than timber cut in its bark." Bosc and other French authors (in *Cours Compl. d'Agr. &c.* art. *Aubier, Bois, Quercus, &c.*) strongly recommend this practice, which is followed in some places on the Continent, and in this country

with the oak and larch; but not, as far as we have learned, with any other tree. Monteith finds it by far the most efficient way of seasoning larch timber. He barked some trees in spring, and did not cut them down till autumn, and others stood in the peeled state for two years. After various and extensive trials, he is "decidedly of opinion, that the larch treated in this way at thirty years of age will be found equally durable with a tree cut down at the age of fifty years, and treated in the ordinary way." (*Forester's Guide*, 152.)

4059. *As the dry rot* (*Merùlius lachrymans Schum.*) is found to arise in a great measure from want of seasoning, or at least to proceed with the greatest rapidity in timber not well seasoned, this practice seems to deserve adoption in that point of view. (*Encyc. Brit. Suppl. art. Dry Rot.*) In some parts of the north of Europe, the trees are divested of their bark for a foot or two feet in height from the ground a year or more previous to that on which they are to be felled. We saw this done in Poland and Lithuania; but, though we made diligent enquiry there and in Sweden, we could not learn distinctly the extent to which it was practised in the latter country and Norway. It is occasionally practised in Poland, for the ostensible purpose of hardening the soft wood: but also accompanied by a deep incision made for the purpose of extracting tar; a practice evidently injurious to the timber, and therefore generally, in these countries, kept out of view. When trees stand close together, a very obvious preparation for felling is lightening the tops of such branches as would, in falling, do injury to the trees that are to be left, or to other adjoining objects.

4060. *The season of felling* is commonly winter, for timber not to be disbarked; but some, for the reasonous tribe, recommend summer, as being the season in which it is generally felled in the north of Europe and in the Alps. But the summer season is there adopted from necessity, as in winter the woods are so filled up with snow that felling is hardly practicable. As the timber of these countries is generally squared for the market, the soft wood is chiefly removed; so that the season of felling does not seem to them to be of much consequence. Besides, the timber is never so full of sap in summer as it is in spring and autumn, and therefore, next to midwinter, midsummer may be the best time for felling all kinds of timber trees. Where the trees are disbarked at the base a year or more before felling, the soft wood will be partially hardened; but this practice is by no means general in the North.

4061. *Knowles*, in a recent work on preserving the British navy, and on dry rot, &c., after collecting the opinions of all the ancient and modern authors who have written on felling timber, concludes that the common notion that trees felled in winter contain less of sap or of the vegetable juices, than those cut down at any other season of the year, is not true; and that the method of barking standing trees in spring, and not felling them till the succeeding winter, has not in any way realised the expectations formed of the plan. After describing all the modes that have been adopted for seasoning timber, he concludes that the best is to "keep it in air, neither very dry nor very moist; and to protect it from the sun and rain by a roof raised sufficiently high over it, so as to prevent, by this and other means, a rapid rush of air." (*Inquiry into the Means of preserving the British Navy from Dry Rot, &c. by Knowles, Sec. to the Com. of Surveyors.* chap. iii.)

4062. *The operation of felling* is performed either by digging an excavation round the stem, and cutting the roots at two or three feet in distance from it, or by cutting over the stem at the surface. By the former mode the root is obtained for use, and the ground more effectually cleared and prepared for the roots of adjoining trees, or whatever crop is to follow. Where the tree is intended to stole, which can very seldom be advisable in the case of cutting full-grown timber, or where there is some nicety requisite in taking it down, so as not to injure other trees or adjoining objects, it is cut or sawn over, and the root, if to be removed, dug out afterwards. "In cutting large trees, in order to make the tree fall the way required, enter the cross-cut saw on that side of the tree it is intended to fall, and cut it about a third part through; then enter the saw at the other side, and when it is cut so far as to admit a wedge, place the wedge exactly opposite the way you want the tree to fall, and keep driving it slowly till the tree is nearly cut through." (*Monteith.*) The tree, being felled, is next divested of its branches, which are sorted into fence wood, fuel, ton-wood, &c., according to the kind of tree; and the trunk is generally preserved as entire as possible for the purchaser. Sometimes it is cut in two, and the root-cut, or but-end, being the most valuable, sold for one class of purposes at a higher price, and the top-cuts for others somewhat lower.

4063. *The seasoning of timber* consists in evaporating the fluid matter or sap by the natural warmth of the atmosphere, with the precaution of screening the timber both from the direct action of the sun and wind, otherwise it cracks, and receives much injury. As this process proceeds slowly and irregularly when conducted in the ordinary way, Mr. Langton has discovered a new method of seasoning timber, consisting in the removal of the greater part of the atmospheric pressure, and the application of artificial heat, by which the time necessary to season green timber, and render it fit for use, is only about twice as many weeks as the ordinary process requires years. In this process the power of an air-pump is added to draw the sap out of the interior of the wood; and the tendency of the fluid to the outside being thus increased, a higher temperature than that of the atmosphere can be applied, with less risk of causing the timber to split; consequently the process may be completed in less time, and a few trials will show the best relation between the time and heat for the different kinds of wood. The late Mr. Tredgold's opinion being asked, he gave it as decidedly in favour of Mr. Langton's process; and timber is now completely seasoned by Mr. Langton in eight or ten weeks after the tree is cut down. (*Newton's Journal*, vol. i. 2d series, p. 144.)

4064. *Seasoning timber by steeping.* "Some remarkable facts respecting the durability that may be given to timber by artificial means have been observed at Closeburn. The proprietor of that estate has, for thirty years, been in the constant practice of soaking all fir and larch timber, after it is sawed into planks, in a pond or cistern of water strongly impregnated with lime. In consequence of this soaking, the saccharine matter in the wood, on which the worm is believed to live, is either altogether changed, or completely destroyed. Scotch fir-wood, employed in roofing houses, and other indoor work, treated in this manner, has stood in such situations for thirty years, sound, and without the vestige of a worm. In a very few years fir-timber so employed, without such preparation, would be eaten through by that insect." (*Monteith of Closeburn, in Edin. New Phil. Journ.* June, 1828.)

4065. *The roots of trees* are the last product we shall mention. These should, in almost every case, be effectually eradicated; to aid in which, in the case of very large roots, splitting by wedges, rifting by gunpowder, tearing up by the hydrostatic press, or by a common lever, may be resorted to. Some compact ash or oak roots are occasionally in demand by smiths, leather-cutters, and others; but, in general, roots should be reduced to pieces not exceeding three feet long, and six inches in diameter, and put up in stacks not less than three feet every way, but commonly containing two cubic yards. These, when dry, are sold for fuel, or reduced to charcoal on the spot. In eradicating and stacking up coppice-woods, it is common to allow a certain sum per stack, and something for every acre of ground cleared; if there are no trees to bark, allowances are also made for the poles, faggots, &c., so that no part of the operation is performed by day work.

4066. *The usual method of charring wood* is as follows:—The wood being collected near the place intended for the operation, and cut into billets, generally about three feet

in length, the pits or stacks are usually formed in this manner:—A spot adapted to the purpose, of from about fifteen or twenty feet in diameter, of a conical form, is selected, and after being properly levelled, a large billet of wood, split across at one end, and pointed at the other, is fixed in the centre of the area, with its pointed extremity in the earth, and two pieces of wood, inserted through the clefts of the other end, forming four right angles; against these cross-pieces, four other billets of wood are placed, one end on the ground, and the other leaning against the angles. A number of large and straight billets are afterwards laid on the ground, to form a floor, each being, as it were, the radius of the circular area; on this floor, a proper quantity of brush or small wood is strewed, to fill up the interstices, when the floor will be complete: and in order to keep the billets in the same position in which they were first arranged, pegs or stumps are driven into the ground, in the circumference of the circle, about a foot distant from one another; upon this floor a stage is built, with billets set upon one end, somewhat inclining towards the central billet, and on the tops of these another floor is laid, in a horizontal direction, but of shorter billets, as the whole is intended, when finished, to form a cone. The pile is then coated over with turf, and the surface generally plastered with a mixture of earth and charcoal dust.

4067. *Previously to the operation of setting fire to the pile*, the central billet in the upper stage is drawn out, and pieces of dry combustible wood substituted in its place, to which the fire is applied. Great attention is necessary during the process, in the proper management of the fire, and in immediately covering up the apertures through which the flame obtrudes itself, until the operation be concluded, which is generally effected in the space of two or three days, according to circumstances. When the charcoal is thought to be sufficiently burnt, which is easily known from the appearance of the smoke, and the flames no longer issuing with impetuosity through the vents, all the apertures are to be closed up very carefully, with a mixture of earth and charcoal dust, which, by excluding all access of the external air, prevents the coal from being any further consumed, and the fire goes out of itself. In this condition it is suffered to remain, till the whole is sufficiently cooled; when the cover is removed, and the charcoal is taken away. If the whole process is skilfully managed, the coals will exactly retain the figure of the pieces of wood: some are said to have been so dexterous as to char an arrow without altering even the figure of the feather. (*Encyc. Brit.* vol. v. art. *Charcoal.*)

4068. *The method of charring wood, for the making of gunpowder*, according to an improved system, adopted not many years ago, is however a much more costly operation, though the expense attending it is amply compensated by the superior excellence of the article when manufactured. It is done in iron cylinders, and in so complete a manner, that every particle of the wood is charred. The oily or tarry matter is also preserved, and may, so far as the quantity goes, be made use of instead of foreign tar or pitch. This mode of charring wood for making gunpowder is carried to the greatest perfection near Petworth in Sussex, and there is a manufacture of a similar nature near Chester. (*Gen. Rep. for Scotland*, vol. ii. p. 342.)

SECT. IX. *Estimating the Value of Plantations and their Products, and exposing them to Sale.*

4069. *The valuation of timber forms a distinct profession*, and can only be acquired by continued observation and experience: like other valuations of property, it depends on a great variety of considerations, some of a general, but the greater part of a local nature. We have already offered some remarks on valuing young plantations, as a part of what may be called the inherent value of landed estates (3330.), and shall here confine ourselves to the valuation of saleable trees.

4070. *In valuing saleable trees of any kind*, their number per acre or their total number by enumeration being ascertained, and the kinds and sizes classed, then each class is to be estimated according to its worth as timber, fence-wood, fuel, bark, &c.

4071. *In a coppice wood which cannot readily be measured*, “the readiest method of counting the stools is, to cause two men to take a line, say about a hundred feet long or more, and pass it round as many of the stools as it will enclose, the one man standing while the other moves round a new number of stools: then count always the stools betwixt the two lines, causing the one man to move while the other stands still, and so on alternately. The valuator at the same time taking care to average every twenty stools as they go on, before losing sight of the counted stools. This way, too, is a very speedy and sure method of counting the number of trees in any plantation.”

4072. *Or the stools of a coppice wood may be counted and averaged* “by two men going parallel to each other, and the person valuing going betwixt them; the two men putting up marks with moss, or pieces of white paper, on a branch of the stools; the one man always going back by the last laid marks, and the valuator always counting and averaging the stools betwixt the newly laid and the late made marks; counting and averaging the stools always as the men go on, taking only twenty, or even ten stools at a time. To those who have been in the practice of doing this frequently, it will be found very easy, and will be done very speedily, and with a very considerable degree of accuracy. The proper method of learning to do this correctly is, when a person cuts an oak wood for the first time (or, even were the work repeated several times); he should then, in order to make himself perfectly acquainted with ascertaining the quantity of bark that a stool, or even the stump of a stool, will produce, go before the peelers, and select a stool or stem; after having examined it narrowly, he supposes it to produce a certain quantity of bark, and marks this down in his memorandum book. He then causes a person to peel it by itself, dry it, and carefully tie it up and weigh it, and compare it with the weight he supposed it would produce, and he will at once see how far his calculation approaches the truth. A stem of oak, from a natural stool, suppose it to measure in girth two inches, by seven feet long, will contain two solid inches, and one third of an inch, according to the measurement of Hoppus. This stem or shoot will produce two pounds two ounces of bark. Again, a stem or shoot of natural oak, measuring four inches in

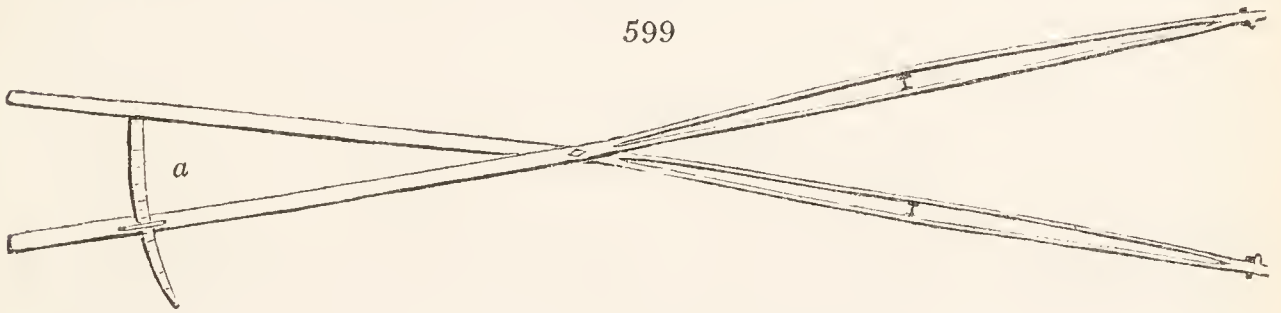
girth, by nine feet in length, will be found to contain one solid foot of wood, and will produce thirteen pounds and a half of bark." (*Forester's Guide*, 170.)

4073. *When growing trees are valued*, an allowance is made from their cubic contents for the bark. The rule given by Monteith is, "When the girth or circumference is any thing from twelve inches up to twenty-four inches, then deduct two inches; from twenty-four to thirty-six, three inches; from thirty-six to forty-eight, four inches; from forty-eight to seventy-two, five inches; and above seventy-two, six inches. These deductions," he says, "will be found to answer in almost all trees; unless in such as are very old, and have rough and corky barks, or barks covered with moss, when an extra allowance is to be made." (*Forester's Guide*, 180.)

4074. *In valuing measurable oak-trees*, many persons proceed on the data that every cubic foot of timber will produce a stone (sixteen pounds) of bark. "This," Monteith says, "is not always correct;" and he states the following facts from his own experience, with a view to assist beginners in ascertaining the quantity of bark from different trees. "An oak-tree, about forty years old, measured down to four inches and a half as the side of the square, and weighing only the bark peeled off the timber that is measured, without including the bark of the spray, &c., every foot of measured timber will produce from nine to eleven pounds of bark. An oak-tree of eighty years old, weighing only the bark peeled off the measurable timber, as above, every foot will produce from ten to thirteen pounds of bark. Every foot of large birch timber, peeled as above, will produce fourteen pounds of bark. Every foot of mountain-ash, as above, will produce eleven pounds and a half of bark. Every foot of the willow, unless a very old one, will produce from nine to eleven pounds of bark. Every foot of larch fir, not exceeding thirty years old, will produce from seven to nine pounds of bark. The bark of trees, particularly the oak, is peeled off, every branch and shoot, down as small as an inch in circumference." (*Forester's Guide*, 189.)

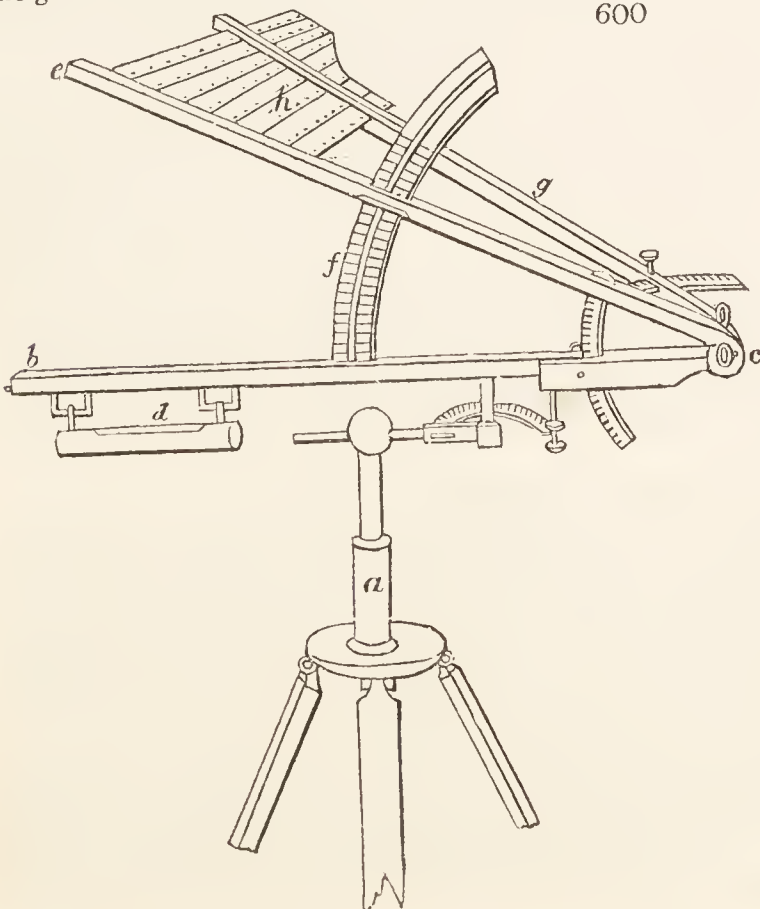
4075. *To facilitate the measuring of standing timber*, various ingenious instruments and machines have been invented, by Monteith, Gorrie, Rogers, and others. Perhaps the most generally useful is Broad's callipers (*fig. 599*). This instrument is composed of two thin pieces of deal about thirteen feet long, with

599



a brass limb or index (*a*), on which are engraven figures denoting the quarter girth in feet and inches. Raising the instrument, the index end (*a*) is taken hold of, and the other applied to that part of the trunk where the girth is to be taken, opening it so wide as just to touch at the same time both sides of it, keeping the graduated index uppermost, on which the quarter girth will be shown, allowing one inch in thirteen for the bark. For taking the height of

600



a tree, rods of deal or bamboo, seven feet long, made so as to fit into ferules at the end of each other, tapering as in a fishing-rod, may be used. Five of them with feet marked on them would enable a man quickly to measure the height of a trunk of more than forty feet as he would reach above seven feet. Monteith's machine being described in the *Encyclopædia of Gardening* (2d edit. § 6970), and Gorrie's in the *Gard. Mag.* (vol. ii. p. 9.), we shall here confine ourselves to the invention of Mr. Rogers.

4076. *Rogers's dendrometer* (*fig. 600*) consists of a tripod stand, and a machine for taking angles horizontally as well as vertically. An upright stem arises from the top plate, at the end of which is a ball, with a hole perforated through it, to receive the horizontal stem of the instrument; *b c* may be called the base limb of the instrument, which is to be placed in a truly horizontal position, and adjusted by the suspended level (*d*). The limb (*e*) rises on a joint at *c*, and slides upon a vertical arch (*f*) which is graduated. At the joint (*c*) there is an eye-piece, through which the surveyor looks along the side of the bar (*b*) to a small point, or rising edge, at the end of the bar; the part of the tree cut by this line of observation will, if the instrument is properly adjusted, be perfectly horizontal with the cyc-piece. An eye-piece is also placed at *c*, on the upper

side of the rising limb, for the purpose of looking along this limb to a point or rising edge (*e*) in its extremity. The surveyor elevates this limb, until that part of the tree intended to be noticed is exactly cut by the line of observation, and the angle subtended between that and the horizontal is shown upon the vertical arch (*f*). It is here to be remarked, that the graduations upon the arch (*f*) are not angles of altitude, but marks or graduations answering to feet and inches of a tangent line, extending from the horizontal point upwards, taken at a given distance from the tree; consequently, there are two or more rows of divisions, answering to the several distances at which the instrument may be planted. Twenty-four feet and forty-eight feet are proposed distances, and the graduations upon the arch (*f*) are made accordingly. For lofty trees, the longer distance is to be used; but for shorter trees, the distance of twenty-four feet will be sufficient. The horizontal angles which are to determine the diameter of the trunk, at the several points of observation, are ascertained by the limb (*g*), which slides laterally upon an arch or graduated plate (*h*) divided upon the same principles as the arch (*f*). The limbs (*b*) or (*e*) being fixed, so as to coincide with one side of the trunk, the limb (*g*) is then moved until it coincides with the other side of the trunk, and the angle subtended between the two shows, by the graduated plate (*h*), the diameter in feet and inches of the trunk at the points of observation. The length of the trunk, and its diameter in the several parts, being thus ascertained by the improved instrument, recourse must then be had to tables, calculations, or the ordinary sliding rule, for the purpose of obtaining from these admeasurements, the solid content of timber in each portion of the tree. There are adjusting screws, and circular racks and pinions for moving the limbs of the instrument, and altering their position, as circumstances may require; and when crooked arms, or bent parts of the trunk present themselves, the instrument may be turned upon its pin, in the ball at the top of the stem (*a*), and used in an inclined position. (*Newton's Jour.* vol. ix. p. 360.)

4077. *The price of timber*, like that of every other article in general use, varies with the supply and demand, and is easily ascertained from the timber-merchants at the different sea-ports; as is that of bark, charcoal, and fire-wood, from the tanners and coal-merchants.

4078. *The usual modes of disposing of timber trees* are, selling the trees standing, by auction, by receiving written proposals, or by bargain and sale; 2d, cutting down the trees, and selling them in the rough, by either of these methods; 3d, converting the fallen trees; that is, cutting them up into the planks or pieces to which they are best adapted, or which are most eligible in the given situation. The first method seems the best, especially on a large scale, and also for the disposal of copse-wood or osier crops.

CHAP. X.

Formation and Management of Orchards.

4079. *The formation of orchards* is to be considered among the permanent improvements of an estate; and should be kept in view in its first arrangement or laying out. No temporary occupier could afford to plant an orchard without extraordinary encouragement from his landlord. Orchards in this respect may be ranked with timber plantations, and both subjects together agree in belonging equally to agriculture and gardening. Orchards have doubtless existed in Britain for many ages as appendages to wealthy religious establishments; but, as objects of farming or field culture, they do not appear to have been adopted till about the beginning of the seventeenth century. (*Lawson.*) They were then introduced by Lord Scudamore in Herefordshire, in which county, and in such parts of those adjoining as exhibit a red marly soil, are the best farm orchards in England. The chief produce of these orchards is cider and perry; but as these liquors are not in very general demand in this country, and are confessedly less wholesome and nourishing than malt liquors, their formation cannot be carried to any great extent. It seems desirable, however, that orchards of moderate size should be as generally introduced as possible; as the use of the fruit in pies, tarts, and sauces would add considerably to the comforts of the lower classes. Besides, there are some situations, as steep sheltered banks of good soil, which cannot be so profitably employed in any other branch of husbandry. The subject of orchards may be considered in regard to soil and situation, sorts of trees, planting, culture, and the manufacture or disposal of the produce.

SECT. I. *Soils and Situations most suitable for Orchards.*

4080. *The sites of all the best apple orchards*, and all the chief cider districts, have been discovered by W. Smith to be on the same stratum of red marl which stretches across the island from Dorsetshire to Yorkshire. Fruit of no kind, indeed, can be raised with much success on a soil that does not contain in its composition a portion of calcareous matter: though apple trees will thrive well on any description of clay which has a dry bottom, and pears and plums on any dry-bottomed soil whatever.

4081. *The most desirable aspect* is unquestionably a somewhat elevated and naturally sheltered declivity, open to the south and south-east; but, as the author of *The Herefordshire Survey* remarks, orchards are now found "in every aspect, and on soil of every quality, and under every culture." The most approved site, he says, is that which is open to the south-east, and sheltered in other points, but particularly in that opposite.

Much however depends on the character of the winds of a country; for in some parts of the island, the west, and in others the east or north wind, is the most injurious to vegetation.

4082. *The soil* which in Herefordshire is considered best adapted to most kinds of apples is a deep and rich loam when under the culture of the plough; on this, the trees grow with the greatest luxuriance, and produce the richest fruit. Some trees however, the stire and the golden pippins in particular, form exceptions to this general rule, and flourish most in hot shallow soils on a lime or sandstone. The best sorts of pear-trees also prefer the rich loam, but inferior kinds will even flourish where the soil will scarcely produce herbage. An orchard is generally raised with most success and at least expense in a hop-yard, the ground under this culture being always well tilled and manured, as well as fenced against every kind of enemy.

4083. *The soils and situations devoted to farm orchards in Scotland* are steep clayey banks sheltered from the more violent and injurious winds; and in whatever part of that country such situations occur, they can scarcely be more profitably employed. Fruit trees of the apple, pear, and cherry kind, especially of the hardier and tall vigorous-growing varieties, might be introduced in the hedge-rows of dry and moderately sheltered grass-lands in most parts of the British Isles. By thus rendering these fruits universal, there would be a considerable accession of enjoyment to the lower classes, and less temptation to break into gardens and orchards.

4084. *The commercial situation* most desirable for an orchard is, of course, near a market town, or near a ready conveyance to one; because though the making of cider affords a profit, yet the fruit sold for culinary or table use yields a much more considerable one. In *The Gloucestershire Report* it is stated that the fruit, which would fetch 8l. 16s. unground, would only bring in cider 3l. 15s.

SECT. II. *Sorts of Trees, and Manner of Planting.*

4085. *The most generally useful fruit* that can be grown in farm orchards is the apple; next the pear; then the plum for tarts or wine; and to these may be added the cherry, filbert, walnut, chestnut, and elder. In the cider countries, where the climate is more certain than in some others, it is customary to plant but a few good sorts; and not to mix above one or two sorts together in making cider: in the northern districts, on the contrary, it is a maxim to plant a considerable number of different sorts, both of those which blossom early and late; because, should the blossom of one variety be destroyed by a frosty wind, that of another may escape. In cold districts, it is advisable to plant orchards in sheltered hollows, exposed to the sun, and to plant thick: but in the warmer southern counties, many descriptions of cider and perry fruits may be grown to perfection in the hedge-rows, or as cultured trees in permanent pastures. The fittest trees for such purposes are those which grow tall, with upright shoots, and which bear fruit of a small size; such as the Siberian pippin apple, and squash teinton pear: such trees shade the hedges or pastures less than the spreading kinds, and their fruit, being small, is less likely to be blown down by high winds.

4086. *The most approved sorts of cider apples* we have enumerated and partially described in the accompanying table (4089). It will be particularly observed that some of the sorts form much more handsome trees than others, and should therefore be preferred for hedge-rows, and indeed in all cases where the quality of the fruit is not objectionable. Some also have smaller-sized fruit than others, and these are to be preferred for situations exposed to much wind.

4087. *The colours of good cider fruit* are red and yellow; the colour to be avoided is green, as affording a liquor of the harshest and generally of the poorest quality. The pulp should be yellow, and the taste rich and somewhat astringent. Apples of a small size are always, if equal in quality, to be preferred to those of a larger, in order that the rind and kernel, which contain the aromatic part, may be the more easily crushed with the pulp.

4088. *The sorts of baking apples most suitable for orchards* are the calvilles, of which there are several varieties, including the Hawthornden for early use; the reinettes, pearmains, and Northern greening for autumn use, and the russets and Padley's pippin for winter and spring. Many other sorts might be named, but an inspection of the fruit markets will prove that these are the best; and further details belong to books on gardening. Whoever intends to plant an orchard will do well to describe the soil, situation, climate, and object in view, to the nearest resident gardener or nurseryman of science and great experience; because the nomenclature of fruits is at present too uncertain to justify any one in trusting entirely to a selection of names taken from books. Ronalds of Brentford, Gibbs of Amptill and Old Brompton, and Pearson of Chilwell, near Nottingham, are very extensive growers of apple trees for sale, and have paid great attention to the merits of the different sorts.

4089. TABLE OF CIDER APPLES OF ESTABLISHED REPUTATION.

No.	Name.	Synonym.	Origin, where, and where originated, procured, or abounding.	Where figured.	Described.	Size.	Figure.	Colour.	Ripe in	Last till	Consistence & flavour.	Bearer.	Character of the tree, and general reputation of the fruit.
1.	Siberian pippin	-	A seedling from Siberian crab and Loam's pearmain, by Knight	-	Kn. Tr. 176.	Small	Fla. orbic.	Yellow	Chms.	March	Firm and juicy	Great	Upright sm.-leaved, hardy tree. Specific grav. of juice, 1079, exceeds almost every apple formerly in culture as a cider fruit
2.	Grange pippin	-	A seedling by Knight, say	-	Hort. Tr. i. 229.	Small	Roundish	Yellow and red	Oct.	Feb.	Firm, juicy, acid	Great	Upright, hardy tree
3.	Foxley	-	A seedling by Knight, say of	-	Kn. Tr. 177.	Very s.	Roundish	Orange and red	Chms.	March	Firm and juicy	Great	Upright, hardy tree
4.	Siberian Harvey	-	A new variety by Knight,	-	Hort. Tr. i. t. 229.	Small	Round	Bright red and green	Chms.	March	Firm and austere	Great	Elegant, upright, sm.-leaved tree
5.	Alban	-	A seedling by the Rev. T. Alban, of Herefordshire, in	-	Kn. Tr. 173.	Small	Round	Red and green	Chms.	Feb.	Firm and very harsh	Indiff.	Delicate tree; spec. grav. ju. 1073
6.	Hogshead	-	A Herefordshire seedling	-	Forsyth, 77.	Small	Roundish	Deep red	Jan.	March	Firm and austere	Great	Upright, handsome tree
7.	Stead's kernel	-	A Herefordshire seedling	-	Kn. Tr. 174.	Med.	Round	Yellow & russet spots	Jan.	March	Firm and austere	Good	Small-leaved tree; specific gravity of juice, 1074
8.	Large sire	-	A Herefordshire apple	-	Forsyth, 96.	Small	Ovate	Yellow and red	Nov.	Feb.	Firm and sharp	Good	An upright-twigged tree
9.	Breinton seedling	-	A Herefordshire seedling	-	Kn. Tr. 172.	Small	Ovate	Yellow and red	Jan.	March	Firm and juicy	Med.	A free-growing tree in good soil; specific gravity of juice, 1067
10.	Brierly's seedling	-	A Herefordshire seedling	-	Kn. Tr. 173.	Small	Round	Yellow	Jan.	March	Firm and austere	Good	A free-growing tree; specific gravity of juice, 1050
11.	Hagloe	-	An esteemed Herefordshire fruit	-	Forsyth, 68.	bel. me.	Conical	Yellow	Jan.	May	Firm and tart	Great	Upright, small-leaved tree
12.	Woodcock	-	A Herefordshire variety yet in a vigorous state	Pom. Her. t. 5.	Forsyth, 194.	ab. me.	Conical	Dark red and yellow	Jan.	March	Firm and austere	Great	Narrow-leaved, upright tree
13.	Yellow Siberian	-	From the Siberian crab and Loam's pearmain, by Knight	-	Kn. Tr. 175.	Very s.	Round	Very yellow	Jan.	March	Firm, austere	Great	Upright, hands. tree, one of the very best cider apples; specific gravity of juice, 1085
14.	*Maiden's blush	-	-	-	Forsyth, 108.	Small	Roundish	Dark mahogany	Oct.	March	Firm and acid	Good	Hardy, upright-growing tree
15.	*New red must	-	-	-	Forsyth, 119.	Large	Round	Pale red and green	Dec.	Feb.	Firm and acid	Great	Hardy, spreading tree; much esteemed in the cider countries
16.	*Old red must	-	-	-	Forsyth, 151.	Large	Ovate	Pale red and green	Jan.	June	Firm and acid	Great	Fine showy tree
17.	*Fawsan	-	-	-	Forsyth, 156.	bel. me.	Conical	Greenish yellow	Dec.	May	Firm and sharp	Great	Vigorous tree, broad leaves
18.	*Redstreak	-	-	-	Forsyth, 152.	Med.	Oblong	Green, strk. with red	Jan.	April	Firm and sharp	Good	Vigorous, upright tree
19.	*Court pendu	-	A Herefordshire fruit	Pom. Her. t. 1.	Forsyth, 49.	Large	Ovate	Deep green and red	Chms.	Chms.	Firm, sharp	Great	Hands. upr. tree; most valuable fruit
20.	French crab	-	-	-	Hort. Tr. ii. 104.	Small	Round	Gold and green	Nov.	March	Firm, aromatic	Good	Delicate, slender-twigged tree; fruit fit both for table and cider
21.	*Warwickshire	-	Resembles the golden pip.	-	Forsyth, 72.	Large	Ovate	Green russet	Chms.	May	Firm and sweet	Great	Upright tree
22.	*Harvey's	-	-	-	Forsyth, 186.	Med.	Conical	Dark russet	Chms.	May	Firm and aromatic	Good	Upright slen. tree; esteemed fr.
23.	Wine	-	-	-	Forsyth, 24.	bel. me.	Flat, rou.	Russet, and some gr.	Jan.	June	Firm and juicy	Good	Upright-growing tree; valu. fr.
24.	Cornish	-	-	-	Forsyth, 185.	Med.	Long	Yellowish	Jan.	March	Firm and sugary	Good	Spreading tree; fruit hangs down
25.	*White court pendu	-	-	-	Hort. Tr. i. 145.	Small	Round	Yellow	Oct.	March	Firm and sweet	Small	Ditto juicy, ranks next golden pippin for dessert and cider
26.	*Downton	-	Seedling by Knight	Pom. Her. t. 9.	Hort. Tr. i. 69.	Small	Round	Reddish green	Oct.	March	Firm and sweet	Good	Hardy tree
27.	*Bringwood	-	Seedling by Knight	-	Forsyth, 188.	Large	Round	Strk. white, red & yel.	Sept.	March	Rich and sweet	Good	Luxuriant tree
28.	Whitmore	-	-	-	Hort. Tr. i. 227.	Med.	Round	Yellow	Nov.	May	Firm, sweet	Good	Large handsome tree
29.	Yellow Ingestrie	-	Resembles gold. p.	-	Hort. Tr. i. 227.	Med.	Round	Red	Oct.	Feb.	Firm, juicy	Good	Large handsome tree
30.	Red Ingestrie	-	Resembles gold. p.	-	Hort. Tr. i. 229.	Med.	Conical	Yellow and red	Oct.	Feb.	Firm, juicy	Good	Vigorous tree
31.	Wormsley	-	-	-	Hort. Tr. i. 229.	Large	Conical	Yellow and red	Oct.	Feb.	Firm and vinous	Good	Free-growing tree
32.	Elton's yel. kernel	-	-	-	Forsyth, 40.	Med.	Round	Yellow	Jan.	March	Firm and juicy	Great	Large-spreading tree; showy fr.
33.	Sykehouse	-	A Yorkshire apple	Hook. Pom. t. 40.	Forsyth, 168.	Small	Round	Orange, red, and yel.	Jan.	April	Firm and juicy	Great	Very hardy tree
34.	Trevoider	-	-	-	Forsyth, 182.	Med.	Round	Yellow and red	Chms.	May	Firm	Good	Free grower; esteemed fruit
35.	Bovey redstreak	-	-	-	Forsyth, 12.	Med.	Flat small eye	Deep red and white	Jan.	April	Firm, sub-acid	Good	Free grower; esteemed fruit
36.	Cockagee	-	-	-	Forsyth, 22.	-	-	Red and yellow	Oct.	Dec.	Soft and sharp	Great	Vigorous tree; fruit good for table, baking, or cider
37.	Minshul crab	-	A Lancashire seedling, say	-	Forsyth, 114.	Med.	Roundish	Yel. with brown spots	Sept.	April	Firm, sharp	Great	Upr. vig. tr.; fr. usef. for every pur.
38.	Redstreak	-	Seedling of Wiltshire, say	-	Forsyth, 153.	Med.	Round	Yel. streaked with red	Sept.	Oct.	Soft and acid	Good	Free-growing spreading tree.

4090. *The dessert apples fit for orchards* are the rathripes or Margarets for earliest use ; the Juneating, pomeroiy, summer pearmain, and Kentish codling for summer use ; the golden, Downton, and other pippins, especially the ribston pippin, with the nonpareil and other small russets, for autumn, winter, and spring use. The following list is given by Nicol as including a fit collection both of kitchen and dessert apples for a private orchard ; those marked thus * being preferable : —

Ribston pippin, * oslin ditto, * gogar ditto, * Kentish ditto, * royal codling, * Kentish ditto, * Carlisle ditto, * royal russet, Wheeler's ditto, * royal pearmain, * Loan's ditto (good), * golden reinette, * Kentish ditto (good), * grey Leadington, scarlet

ditto, summer greening, winter ditto, * Yorkshire greening, * margil (very good), Margaret apple (good), * white Hawthornden, * Norfolk beaufin (good), strawberry, * purse-mouth (very good).

4091. *The most approved sorts of cider pears* are the following : —

Barland, Pom. Her. t. 27., Forsyth, p. 143., fruit very austere, hardy upright tree. Holmore, Pom. Her. t. 20., Forsyth, p. 144., upright tree. Huffcap, Pom. Her. t. 24., Forsyth, p. 144., fruit austere, large, hardy trees. Oldfield, Pom. Her.

t. 11., Forsyth, p. 144., large tree. Rough cap, Forsyth, p. 144., very austere, hardy free-growing tree. Squash teinton, Pom. Her. t. 13., Forsyth, p. 144., fruit very austere, upright tree, and great bearer.

4092. *In choosing pears for planting in orchards*, the description of the plant is a matter of very considerable importance, as pear trees attain a much greater age and size than apples. In our opinion the planting of pears in hedge-rows ought to be more encouraged than the planting of apples, as they are calculated, when dried, to be used in soups ; or, when stewed green, to afford a light and agreeable nourishment ; and perry is at least a more wholesome and exhilarating liquor to most constitutions than cider.

4093. *The baking and dessert pears fit for orchards*, according to Nicol, are the following : —

*Jargonelle, Crawford or lammas, * carnock or Drummond, * grey achan, swan's egg, * moorfowl's egg, * yair, * golden knap (good), Longueville, * summer bergamot, * autumn ditto,

* Scot's ditto, musk robin (good), saffron, * hanging leaf (very good), the pound pear, cadillac, warden (for baking).

4094. *Gorrie (Gard. Mag. vol. iv. p. 11.)* recommends the Benvie (*fig. 601. a*), Golden Knap (*b*),

601



Elcho (*c*), Busked Lady (*d*), and Pow Meg (*e*), as handsome trees. But where high-flavoured fruit is the object, and the climate is not unfavourable, the Beurrés, the Bergamots, and other new French and Flemish sorts, should be preferred. The following sorts will succeed as standards in the neighbourhood of London. Their time of ripening is indicated, and also their qualities : very good (v. g.) ; good (g.) ; and moderate (m.).

July. * Muscat Robert (m.), gros muscat. (g.)
 Aug. Epine verte d'été (g.), * jargonelle. (v. g.)
 Autumn. * Bergamote silvange (g.), * beurré rouge (g.), beurré vert. (g.)
 Sept. * Bergamote paysanne (v. g.), rousset de Rheims. (v. g.)
 Sept. and Oct. Fondante d'Havay (v. g.), * bon chrétien d'été. (g.)
 Oct. Fondante de Brest (v. g.), épine d'hiver. (g.)
 Oct. and Nov. * Beurré Spence (v. g.), * Marie Christine. (v. g.)
 Nov. Beurré Capiaumont (v. g.), beurré crapaud (v. g.), beurré d'Afflighem (v. g.), Marie Louise (v. g.), * Napoleon (v. g.), * Urbaniste. (v. g.)
 Dec. Beurré diel (v. g.), pastorale (g.), * présent de Mardes. (v. g.)

Winter. Josephine (v. g.), poire Canning. (v. g.)
 Dec. and Jan. * Gloux morceaux (v. g.), Roi de Rome. (g.)
 Jan. Bezi Vaat (v. g.), * Louise Bonne. (g.)
 Jan. and Feb. * Passe Colmar (v. g.), * Passe Colmar gris, dit Précel. (v. g.)
 Feb. and March. Orangé d'hiver (m.), l'incommunicable. (m.)
 March. Duchesse de Mars. (g.)
 March and April. Gros Romain (m.), * bergamote de Pâques (m.), * beurré rance. (v. g.)
 April. Fondante Batave (g.), la favorite. (g.)
 April and May. Muscat Allemand (m.), bezi de Caissoy. (g.)
 May and June. * Bergamote de Pentecôte (g.), Rame-lier. (m.)

4095. *The best sorts of baking plums* are the following : —

Danson, bullace, muscle, winesour, and magnum bonum. Of these the damson is by far the best, and next the winesour,

which thrives only on a calcareous soil, and grows wild in abundance in the West Riding of Yorkshire.

4096. *The following are excellent dessert plums* for an orchard : —

* Green gage, Orleans, * damask (black, good), white perdri-gon, * blue ditto, blue gage, * white magnum bonum, red

ditto, or imperial, * drap d'or (yellow, good). Of these the green gage, Orleans, and damask are much the best.

4097. *Gibbs of Brompton* gives the following select list of orchard fruits from his own experience : —

Summer Table Apples. Early Margaret, red Astrachan, oslin, Mason's early, Kerry, yellow Ingestrie, Carter's seedling, Thorle, red Quarenden, early Amptill pippin.
 Summer Kitchen Apples. Keswick codlin, Maulden codlin, Carte's monster, French codlin, yellow harvest, Hollandbury,
 Autumn Table Apples. Ribston, Margall, court pendu, Downton, Newtown Spitzenburg, English peach apple,

Fearne's pippin, Wyken, Gravenstein, Ross nonpareil, pomme de neige.

Autumn Kitchen Apples. Alexander, Howbury pippin, Hawthornden, Duchess of Oldenburgh, Nelson, dominic, Blenheim orange, Dutch and French codlins (good for autumn as well as summer use).

Winter and Spring Table Apples. Scarlet nonpareil, old

nonpareil, old golden pippin, Newton pippin, Wheeler's russet, nonpareil russet, Gibb's pippin, court of Wick, Lemon greening of very good quality, Cooper's russet, Sykehouse russet, American seek no further, golden Harvey.

Winter and Spring Kitchen Apples. French crab, Norfolk beaufin, Norfolk Paradise, paywell, winter queen, winter greening, Yorkshire greening, royal russet, beauty of Kent, white Leadington, Fullwood's apple, lemon pippin, skinless pippin, marinalade pippin, winter pearmain.

Cider Apples. Redstreak Somerset, redstreak Devon, redstreak late white Parson's, coccagee, Duffin, woodcock, Styre, Downton, Solebury cider apple, Kingston black, Somerset sweeting.

Summer Table Pears. Citron des carmes, jargonelle, summer bon chrétien, early bergamot, Julien archiduc d'été, green chisel, Lammas.

Summer baking and preserve Pears. Windsor, Edelcrantz, swan's throat, Crawford, lemon.

Autumn Table Pears. Gansel's bergamot, Cresanne, brown

4098. *Ronalds of Brentford*, who is perhaps better acquainted with English apples than any other individual, recommends the following sorts : —

Summer Table Apples. Hicks's fancy, Bell's fine scarlet, red Quarenden, peach apple, la fameuse, summer oslin, summer golden pippin, Duchess of Oldenburgh, Kerry pippin.

Summer baking Apples. Nonesuch, Spring-grove, Manks codlin, Hawthornden, fine striped General Arabin, Wormsley pippin, Carlisle codlin, early Julian, early spice apple.

Autumn Table Apples. Margil, Downton pippin, Keddlestone pippin, Franklin's golden pippin, Delaware, aromatic russet, summer nonpareil, grange apple.

Autumn baking Apples. Hollandbury, beauty of Kent, Salopian apple, golden burr, Russian apple, Emperor Alexander, Carlisle codlin, Gravenstein, yellow bow (American).

Winter Table Apples. Nonpareil, Morris's russet, Bringwood pippin, King George, Sykehouse, Court Wyke pippin, Christie's

beurré, Marie Louise, Napoleon, beurré Spence, sans pippin, poire Anana.

Autumn preserve and baking Pears. Chaumontelle, reine de poire, Scotch Cornuck, black achan, Elsinghaft, Aston-town.

Winter and Spring Table Pears. St. Germain, beurré d'hiver, poire Braddick d'hiver, poire d'Auch, bon chrétien d'hiver, bergamote d'hiver, Venus d'hiver, beurré rance, winter verte longue, bergamote de Pâque, Van Mons, présent de Malines, bon Malinoise, Dillen.

Winter and Spring baking and preserve Pears. Cadillac, black pear of Worcester, Uvedales St. Germain, orange d'hiver, rousselet gros, merveille.

Perry Pears. Aston-town, achan red, achan green, swan's egg, Windsor, grey beurré, orange bergamot.

Cherries. Couronne, black heart, black eagle, Elton, bigereau, white heart.

Plums. Orleans, green gage, winesour, Cooper's large red, bonum magnum, Coe's golden drop.

pippin, brandy apple, Robinson's pippin, new scarlet nonpareil, Fern's pippin, Pedley's pippin, Crofton pippin, nutmeg cockle pippin, Wykin pippin, russet pearmain, Parry's pearmain, new green nonpareil, new golden pippin, tulip apple, court pendu plat rubra, golden Worcester, Dredge's golden pippin.

Winter baking Apples. Large russet, transparent, golden russet, French crab, Minshall crab, Norfolk paradise, French pippin, London pippin, new scarlet pearmain, Kirk's fame, Duke of Wellington, Yorkshire greening, Rymer, Deeping pippin, pound apple (American).

Cider Apples. Bitter sweet, Siberian Hervey, Foxley apple, coccagee, Pyrus (unique, Tartarian crab), Siberian bitter sweet crab, transparent crab, Deeping pippin, Downton pippin, Brentford crab, Girdler's large striped.

4099. *Pearson of Chilwell* recommends the following apples as very select : —

For early Dessert, the Egglestone summering, Waterloo pippin, and Perfect's Juneating. *For middle Season*, the Burgin, Lord Lennox, Pike's pearmain, and Blenheim orange. *For late Keeping*, Wollaton pippin, Bess Pool, Keddlestone pippin, and Hartford's russet. *For Kitchen Use*, early, the

Manks codlin, American summering, and Hawthornden. *For middle Season*, Greenup's pippin, malster, and Barton free-bearer. *For long Keeping*, Caldwell, Normanton wonder, and northern greening. All the foregoing will do well as dwarfs on Paradise stocks. (*Gard. Mag.* vol. vi.)

4100. *The cultivation of the plum* appears to us deserving of more encouragement than it generally meets with. Not only does the fruit make excellent pies and tarts, but it may be kept in large quantities, so as to be ready for that purpose at any period of the year. They also make a sort of wine, and with other fruits and ingredients form one of the best substitutes for port. The damson, bullace, and some other varieties, will grow and bear very high-flavoured fruit in hedges where the soil is dry below and not too thin. The fruit of the sloe is, for wine-making, superior to that of the plum, and nearly as good for tarts.

4101. *The cherry* is of more limited culture than any of the foregoing fruits; because chiefly used for eating, and not being of a nature to keep. Near large towns they may be cultivated to a certain extent. In Kent and Hertfordshire are the cherry orchards which afford the chief supplies for the London market. The sorts are chiefly the caroon, small black or Kentish, the May-duke, and the morello; but Holman's duke, the black heart, and the large gean, will do well in orchards.

4102. *The walnut and Spanish chestnut* may be advantageously planted on the outskirts of orchards to shelter them, and a few of them in hedge-rows where the climate is likely to ripen their fruit. The chestnut can hardly be considered as ripening north of London, or the walnut north of Newcastle. Both trees, however, may be planted for their timber in moderately sheltered situations, in most parts of the British Isles.

4103. *The elder* is not beneath notice as an orchard tree. It need seldom be planted as a standard; but in unpruned hedges on a soft, deep, and rather rich soil, it yields great quantities of fruit, which is readily manufactured into a sort of wine esteemed by many persons when warmed, and forms a comfortable evening draught for the cottager. No tree requires less care: it propagates readily by cuttings or seeds, and requires little or no pruning; but, though it will grow in any soil whatever, it will produce no fruit worth mentioning on any but one tolerably deep and rich, and must be cut down when it begins to show indications of age.

4104. *The filbert, currant, gooseberry, raspberry*, and some other fruits, are cultivated extensively near large towns; but the treatment they require renders them in our opinion unfit for farm orchards.

4105. *In choosing trees for orchards*, standards, sufficiently tall to admit of horses and cattle grazing under them, should always be preferred. Maiden plants, or such as are only two years from the bud or graft, are the most certain of success; the apples being worked on crab, the pears on wilding, and the cherries on gean stocks. The common baking plums need not be grafted at all, but the better sorts should either be grafted or budded on damson stems. Where budded or grafted chestnuts and walnuts can be got, they should always be preferred as coming much sooner into bearing. The former may be had from the Devonshire nurseries, and some public gardeners about London are now attempting to inarch and bud the walnut.

4106. *With respect to the distance at which orchard trees may be planted*, every thing will depend on the use which is intended to be made of the ground. Where the soil is

to be pastured or dug, they may be planted in quincunx and close: but where it is to be ploughed, they should either be planted in rows with sufficient space between for one broad ridge, or two ordinary ones; or they should be planted in squares to admit of ploughing both east and west, and north and south.

4107. *The Herefordshire orchardists* recommend that the rows should extend from north to south, as in that direction each part of every tree will receive the most equal portions of light and heat. The distance between each row, as well as the space between each tree, should depend on the situation and soil. Where the former is high and exposed, the trees should be closely planted to afford each other protection; and where the latter is poor and shallow, their growth will of course be less luxuriant, and they will consequently require less room. But in low and sheltered situations, and in deep and rich soils, wider intervals should be allowed. In the former instances, twelve yards between each row, and six between each tree, are sufficient; in the latter, twenty-four yards between each row, and eight between each tree, will not be too much.

4108. *As a general guide with regard to distance*, Nicol states the extreme limits at which apple and pear trees should stand, in a properly planted and close orchard, as from thirty to forty feet, less or more, according to the quality of the soil, taking, as the medium, thirty-six feet. In a poor soil and a bleak exposure, where the trees may not be expected to grow very freely, thirty feet are sufficient; whereas in good soil, and a sheltered situation, forty may not be too much. Cherries and plums may be planted at from twenty-four to thirty-six feet, according to soil and situation, as above, taking as a medium, thirty feet for the ultimate distance at which they are to stand clear of one another. But it would be advisable, in the first instance, to plant four trees for one that is intended ultimately to remain, planting the proper kinds at the above distances first, and then temporary plants between them each way. These temporary plants should be of the free-growing sorts that begin to bear early; such as the nonesuch and Hawthornden apples, the May-duke cherry, and the Crawford and yair pears; or any others known to produce fruit sooner after planting. These should be considered and be treated as temporary plants from the beginning, and must give place to the principal trees as they advance in growth, by being pruned away bit by bit, and at last stubbed up entirely. In bleak situations, if forest and other hardy trees be planted among the fruit trees, it may not be necessary to plant so many (if any) temporary fruit trees; or these may chiefly consist of the hardier sorts, such as the Hawthornden apple, the May-duke and morello cherries, and the Scotch geans, which produce fruit the soonest.

4109. *In the operation of planting*, great care ought to be taken not to insert the plants deeper in the soil than they were before removal. This is a very common error in every description of tree planting; and in retentive soils is ruinous to the tree. Sir C. M. Burrel recommends, as a useful practice, in wet soils, or where the substratum is not suited to the apple or the pear, to plant the trees on hillocks of easy ascent, as for instance one foot higher in the centre than the level of the field, and sloping gradually to that level for three or four feet every way from the centre. By this practice, the roots will naturally follow the good surface earth; whereas, if they are planted in holes, the roots are apt to shoot into the prejudicial subsoil, to the eventual injury of the plants by canker and other diseases. When trees are thus planted on small hillocks, the under-drains may pass between the rows with greater utility.

SECT. III. *Cultivation of Farm Orchards.*

4110. *The trees being carefully planted, watered, and tied to tall strong stakes*, require little more than common attention for several years. Every autumn or spring they should be looked over, and all cross irregular shoots made during the preceding summer cut out, suckers (if any) removed from their roots, and side growths cleared from their stems.

4111. *The object in pruning young trees*, Nicol observes, is to form a proper head. Generally speaking, the shoots may be pruned in proportion to their lengths, cutting clean away such as cross one another, and fanning the tree out towards the extremities on all sides; thereby keeping it equally poised, and fit to resist the effects of high winds. When it is wished to throw a young tree into a bearing state, which should not be thought of, however, sooner than the third or fourth year after planting, the leading branches should be very little shortened, and the lower or side branches not at all; nor should the knife be used, unless to cut out such shoots as cross one another.

4112. *After an orchard-tree is come into bearing*, Abercrombie says, continue at the time of winter pruning either every year, or every two, three, or four years, as an occasion is perceived, to cut out unproductive wood, crowded spray, and decayed parts. Also reduce long and outrunning ramblers and low stragglers, cutting them to some good lateral that grows within its limits. Where fruit-spurs are too numerous, then cut the strongest and most unsightly. Also keep the tree pretty open in the middle. If it be necessary to take off large branches from aged trees, use a chisel or saw, and afterwards smooth the wound with a sharp knife. In case old wood is to be cut down to young shoots springing below, to make the separation in summer will be of more advantage to those young shoots, though it is not a common practice, on account of the liability of many stone-fruit bearers to exude gum, when a large branch is lopped in the growing season. Observe to keep the stem clear from all lateral shoots, and eradicate all suckers from the root.

4113. *On aged trees* that have run into a confusion of shoots and branches, and whose spurs have become clustered and crowded, the saw and the knife may be exercised with freedom, observing to cut clean away all useless spray, rotten stumps, and the like useless excrescences. Thin out the spurs moderately to let the air circulate freely among the

leaves and fruit in the summer season, and to admit the rays of the sun, so as to give the fruit colour and flavour.

4114. *In pruning the apple tree and all other standard trees*, Knight observes, the points of the external branches should be every where rendered thin and pervious to the light, so that the internal parts of the tree may not be wholly shaded by the external parts: the light should penetrate deeply into the tree on every side; but not any where through it. When the pruner has judiciously executed his work, every part of the tree, internal as well as external, will be productive of fruit; and the internal part, in unfavourable seasons, will rather receive protection than injury from the external. A tree thus pruned will not only produce much more fruit, but will also be able to support a much heavier load of it, without danger of being broken: for any given weight will depress the branch, not simply in proportion to its quantity, but in the compound proportion of its quantity and of its horizontal distance from the point of suspension, by a mode of action similar to that of the weight on the beam of the steel-yard; and hence a hundred and fifty pounds, suspended at one foot in distance from the trunk, will depress the branch which supports it no more than ten pounds, at fifteen feet in distance, would do. Every tree will, therefore, support a larger weight of fruit without danger of being broken, in proportion as the parts of such weight are made to approach nearer to its centre.

4115. *Where a tree is stunted, or the head ill-shaped*, from being originally badly pruned or barren, from having overborne itself, or from constitutional weakness, the most expeditious remedy is to head down the plant to within three, four, or five eyes (or inches, if an old tree), of the top of the stem, in order to furnish it with a new head. The recovery of a languishing tree, if not too old, will be further promoted by taking it up at the same time, and pruning the roots; for as, on the one hand, the depriving too luxuriant a tree of part even of its sound healthy roots will moderate its vigour; so, on the other, to relieve a stunted or sickly tree of cankered or decayed roots, to prune the extremities of sound roots, and especially to shorten the dangling tap-roots of a plant affected by a bad sub-soil, are, in connection with heading down, or very short pruning, the renovation of the soil, and draining, the most availing remedies that can be tried.

4116. *A tree often becomes stunted from an accumulation of moss*, which affects the functions of the bark, and renders the tree unfruitful. This evil is to be removed by scraping the stems and branches of an old tree; and on a young tree a hard brush will effect the purpose. Wherever the bark is decayed or cracked, Abercrombie and Forsyth direct its removal. Lyon, of Edinburgh, has lately carried this practice to so great a length as even to recommend the removal of part of the bark of young trees. Practical men, in general, however, confine the operation to cracked bark, which nature seems to attempt throwing off; and the effect in rendering the tree more fruitful and luxuriant is acknowledged by Neill in his *Account of Scottish Gardening and Orchards*, and by different writers in *The London and Caledonian Horticultural Transactions*.

4117. *The other diseases to which orchard trees are subject* are chiefly the canker, gum, mildew, and blight, which, as we have already observed, are rather to be prevented by such culture as will induce a healthy state, than to be remedied by topical applications. Too much lime, Sir H. Davy thinks, may bring on the canker, and if so, the replacing a part of such soil with alluvial or vegetable earth would be of service. The gum, it is said, may be *constitutional*, arising from offensive matter in the soil; or *local*, arising from external injury. In the former case, improve the soil; in the latter, apply the knife. The mildew, it is observed by T. A. Knight and Abercrombie, "may be easily subdued at its appearance, by scattering flour of sulphur upon the infected parts." As this disease is now generally considered the growth of parasitical fungi, the above remedy is likely to succeed. For *caterpillars* and other insects in spring, Forsyth recommends burning rotten wood, weeds, potato-hulm, wet straw, &c., on the windward side of the trees when they are in blossom. He also recommends washing the stems and branches of all orchard trees with a mixture of "fresh cow-dung with urine and soap-suds, as a whitewasher would wash the ceiling or walls of a room." The promised advantages are, destruction of insects and "fine bark;" more especially, he adds, "when you see it necessary to take all the outer bark off."

4118. *With the Herefordshire orchardists pruning is not in general use*; the most approved method is that of rendering thin and pervious to the light the points of the external branches, so that the internal branches of the tree may not be wholly shaded by the external parts. Large branches should rarely or never be amputated. The instrument generally used for the purpose of pruning is a strong flat chisel, fixed to a handle six feet or more in length, having a sharp edge on one of its sides and a hook on the other. (*Knight's Treatise on the Apple and Pear.*)

4119. *The culture of the soil among orchard trees* is always attended with advantage; though it can so seldom be properly conducted in farm orchards, that in most cases it is better to lay them down with grass seeds for pasture. To plough between the trees and take corn crops, even if manure is regularly given, cannot be any great advantage, unless

a radius of six or eight feet is left round each tree. If such a space is left, and yearly dug but not cropped, the trees will thrive well; and a ridge between each two rows may be sown with corn. The greater number of orchards in Herefordshire and Gloucestershire are under pasture; but the most productive are those trees grown in hop grounds. In Kent, in some instances, the interspaces of young orchards are occupied by hops, in others by filberts, and in grown orchards the latter are sometimes seen. Some old orchards are likewise in permanent sward, others under arable or garden crops, and some in saintfoin, while others are in lucern. In all cases where the subsoil is moist, or otherwise unfavourable, the ground of an orchard should neither be dug nor ploughed, in order not to prevent the roots from spreading themselves immediately under the surface. The effect of repeatedly stirring the surface to six or eight inches or more in depth is to cause the roots to descend. In all soils, this descent, by furnishing them more abundantly with moisture, tends to prolong the growth, and prevent the ripening of the wood and the formation of blossom buds; but, in the case of noxious subsoils, it brings on canker and other diseases. This is the reason why standard fruit-trees in kitchen gardens are generally less productive than in grass orchards: the productive trees in certain hop-grounds in Kent and other counties may seem an exception; but they are not so, the subsoil in these cases being good and dry.

SECT. IV. *Gathering and Keeping of Orchard Fruit.*

4120. *The gathering of orchard fruit*, and especially apples, should be performed in such a manner as not to damage the branches, or break off the fruit spurs or buds. Too frequently the fruit is allowed to drop, or it is beat and bruised by shaking the tree and using long poles, &c. Nicol directs that it should never be allowed to drop of itself, nor should it be shaken down, but should be pulled by the hand. This may be thought too troublesome a method; but every body knows that bruised fruit will not keep, nor will it bring a full price. The expense of gathering, therefore, may be more than defrayed, if carefully done, by saving the fruit from blemish.

4121. *With regard to the keeping of kernel fruits*, the old practice, which is recommended by Marshal and Forsyth, commences with sweating, though Nicol and other modern gardeners omit this process. It is evident from the general practice of both commercial and private gardeners, that sweating fruit is not essential to its keeping, though some persons continue to allege that, in consequence of that operation, it keeps better. Marshal, the author of *An Introduction to Gardening*, observes, that those fruits which continue long for use should be suffered to hang late, even to November, if the frost will permit; for they must be well ripened or they will shrink. Lay them in heaps till they have sweated a few days, when they must be wiped dry. Let them then lie singly, or at least thinly, for about a fortnight, and be again wiped, and immediately packed in boxes and hampers, lined with double or treble sheets of paper. Place them gently in, and cover them close, so as to keep air out as much as possible. Preserve them from frost through the winter: never use hay for the purpose. Kernel fruits and nuts keep nowhere better than when mixed and covered with sand in a dry cool cellar, in the manner of potatoes. Buried in pits well protected from moisture, russets have been found to keep perfectly fresh a year from the time of their being gathered. The keeping of cider fruits is not approved of, it being found best to crush them after they have been thinly spread for a few days on a dry boarded floor. Many of the Herefordshire growers carry them direct from the tree to the crushing-mill.

SECT. V. *Manufacture of Cider and Perry.*

4122. *Cider is commonly manufactured by the grower* of the fruit, though it would certainly be better for the public if it were made a distinct branch of business like brewing or distilling. "The true way to have excellent cider," Marshal observes, "is to dispose of the fruit to professional cider makers. The principal part of the prime cider sold in London and elsewhere is manufactured by professional men; by men who make a business of manufacturing and rectifying cider, even as distillers, rectifiers of spirit, and brewers follow their businesses or professions, and like them too conduct their operations, more or less, on scientific principles." (*Rev. of Agr. Rep.* vol. ii. p. 294.) It is allowed on all hands that the operation is performed in a most slovenly manner by the farmer, and that it is very difficult to procure this liquor in good quality. The operation of cider-making is as simple as that of wine-making or brewing, and will be perfectly understood from the following directions, chiefly drawn from the treatises of Crocker and Knight; so that any person possessing an orchard, or a few hedge-row fruit trees, may make a supply for his own use. The first business consists of gathering and preparing the fruit; the second, of grinding and pressing; and the last, of fermenting and bottling.

4123. *In gathering cider apples*, care should be taken that they are thoroughly ripe before they are taken from the tree; otherwise the cider will be of a rough, harsh taste, in spite of all the endeavours of the operator. It is observed by Crocker, in his tract

on *The Art of Making and Managing Cider*, that the most certain indications of the ripeness of apples are the fragrance of their smell, and their spontaneously dropping from the trees. When they are in this state of maturity, in a dry day, the limbs may, he says, be slightly shaken, and partly disburdened of their golden store; thus taking such apples only as are ripe, and leaving the unripe longer on the trees, that they may also acquire a due degree of maturity. It may not, he thinks, be amiss to make three gatherings of the crop, keeping each by itself. The latter gathering, as well as wind-falls, can, however, only be employed in making inferior cider: the prime cider must be drawn from the former gatherings.

4124. *On the proper mixture of fruits*, or rather on their proper separation, the merit of cider will always greatly depend. Those whose rinds and pulp are tinged with green, or red without any mixture of yellow, as that colour will disappear in the first stages of fermentation, should be carefully kept apart from such as are yellow, or yellow intermixed with red. The latter kinds, which should remain on the trees till ripe enough to fall without being much shaken, are alone capable of making fine cider. Each kind should be collected separately, as noticed above, and kept till it becomes perfectly mellow. For this purpose, in the common practice of the country, they are placed in heaps of ten inches or a foot thick, and exposed to the sun, air, and rain, not being ever covered, except in very severe frosts. The strength and flavour of the future liquor are increased by keeping the fruit under cover some time before it is ground; but unless a situation can be afforded it, in which it is exposed to a free current of air, and where it can be spread very thin, it is apt to contract an unpleasant smell, which will much affect the cider produced from it. Few farms are provided with proper buildings for this purpose on a large scale, and the improvement of the liquor will not nearly pay the expense of erecting them. It may reasonably be supposed, that much water is absorbed by the fruit in a rainy season; but the quantity of juice yielded by any given quantity of fruit will be found to diminish as it becomes more mellow, even in very wet weather, provided it be ground when thoroughly dry. The advantages therefore, of covering the fruit will probably be much less than may at first sight be expected. No criterion appears to be known, by which the most proper point of maturity in the fruit can be ascertained with accuracy; but it improves as long as it continues to acquire a deeper shade of yellow. Each heap should be examined prior to its being ground, and any decayed or green fruit carefully taken away. The expense of this will be very small, and will be amply repaid by the excellence of the liquor, and the ease with which too great a degree of fermentation may be prevented. (*Crocker.*) In Ireland a mixture of every sort of apple is considered as producing the best cider. A proportion of crabs is always admitted. "The taste, in consequence, is very sour, and less sweet than English cider: but this is matter of fancy; and, a relish for rough cider once acquired, the sweet kind loses much of its attractions. Owing to a considerable admixture of crabs, the Irish cider is always more sour than the English, and this is a quality, when not too predominant, for which it is valued by the natives." (*Lardner's Cyc. Dom. Econ.*)

4125. *In grinding*, the fruit should be so reduced that the rind and kernel should be scarcely discernible. In such a complete mixture it seems probable that new elective attractions will be exerted, and compounds formed which did not exist previously to the fruit being placed under the roller. The process of slow grinding, with free access of air, gives the cider good qualities it did not possess before, probably by the absorption of oxygen. To procure very fine cider, the fruit should be ground and pressed imperfectly, and the pulp spread as thin as possible, exposed to the air, and frequently turned during twenty-four hours, to obtain as large an absorption of air as possible. The pulp should be ground again, and the liquor formerly expressed added, by which the liquor will acquire an increase of strength and richness. (*Lardner's Cyclo. Dom. Econ.*)

4126. *Whether the pommage should, immediately after grinding, be conveyed to the press*, there to be formed into a kind of cake, or what is called the cheese; or whether it should remain some time in that state before pressing, ciderists have not agreed. Some say it should be pressed immediately after grinding; others conceive it best to suffer it to remain in the grinding trough, or in vats employed for the purpose, for twenty-four hours, or even two days, that it may acquire not only a redness of colour, but also that it may form an extract with the rind and kernels. Both extremes are, Crocker thinks, wrong. There is an analogy, he says, between the making of cider from apples, and wine from grapes; and the method which the wine-maker pursues ought to be followed by the cider-maker. When the pulp of the grapes has lain some time in the vats, the vintager thrusts his hand into the pulp, and takes some from the middle of the mass; and when he perceives, by the smell, that the luscious sweetness is gone off, and that his nose is affected with a slight piquancy, he immediately carries it to the press, and by a light pressure expresses his prime juice. In like manner should the ciderist determine

the time when his pulp should be carried to the press. If he carried it immediately from the mill to the press, he might lose some small advantage which may be expected from the rind and kernels, and his liquor might be of lower colour than he may wish. If he suffer it to remain too long unpressed, he will find to his cost that the acetous fermentation will come on before the vinous is perfected, especially in the early part of the cider-making season. He will generally find that his pulp is in a fit state for pressing in about twelve or sixteen hours. If he must of necessity keep it in that state longer, he will find a sensible heat therein, which will engender a premature fermentation; and he must not delay turning it over, thereby to expose the middle of the mass to the influence of the atmosphere. Knight's opinion is, however, that it should remain twenty-four hours before it is taken to the press; and in this opinion the author of the *Art of Cider Making*, in *Lardner's Cyclopædia, Domestic Economy*, vol. i. also concurs.

4127. *The pommage being carried to the press*, and a square cake or cheese made of it, by placing very clean sweet straw or reed between the various layers of pommage; or by putting the same into the hair-cloths, and placing them one on another. It is of importance that the straw or weed be sweet, and perfectly free from any fustiness, lest the cider be impregnated therewith. Particular care ought also to be taken to keep hair-cloths sweet, by frequently washing and drying, or the ill effects of their acidity will be communicated to the cider. To this cake or cheese, after standing awhile, a slight pressure is at first to be given, which must be gradually increased until all the must or juice is expressed; after which, this juice must be strained through a coarse hair sieve, to keep back its gross feculences, and be put into proper vessels. These vessels may be either open vats or close casks; but as, in the time of a plentiful crop of apples, a number of open vats may by the ciderist be considered an incumbrance in his cider-rooms, they should be generally carried immediately from the press to the cask. Thus far, says Crocker, cider-making is a mere manual operation, performed with very little skill in the operator; but here it is that the great art of making good cider commences; nature soon begins to work a wonderful change in this foul-looking, turbid, fulsome, and unwholesome fluid; and, by the process of fermentation alone, converts it into a wholesome, vinous, salubrious, heart-cheering beverage.

4128. *Fermentation* is an internal motion of the parts of a fermentable body. This motion, in the present case, is always accompanied with an evident ebullition, the bubbles rising to the surface, and there forming a scum, or soft and spongy crust, over the whole liquor. This crust is frequently raised and broken by the air as it disengages itself from the liquor, and forces its way through it. This effect continues whilst the fermentation is brisk, but at last gradually ceases. The liquor now appears tolerably clear to the eye, and has a piquant vinous sharpness upon the tongue. If in this state the least hissing noise be heard in the fermenting liquor, the room is too warm, and atmospheric air must be let in at the doors and at the windows. Now, continues Crocker, is the critical moment which the ciderist must not lose sight of; for, if he would have a strong, generous, and pleasant liquor, all further sensible fermentation must be stopped. This is best done by racking off the pure part into open vessels, which must be placed in a more cool situation for a day or two; after which it may again be barrelled, and placed in some moderately cool situation for the winter. The Herefordshire cider-farmers, after the cider has perfected its vinous fermentation, place their casks of cider in open sheds throughout the winter; and, when the spring advances, give the last racking, and then cellar it. In racking, it is advisable that the stream from the racking-cock be small, and that the receiving-tub be but a small depth below the cock, lest, by exciting a violent motion of the parts of the liquor, another fermentation be brought up. The feculence of the cider may be strained through a filtering-bag, and placed among the second-rate ciders; but by no means should it be returned to the prime cider. In this situation the cider will, in course of time, by a sort of insensible fermentation, not only drop the remainder of its gross lees, but will become transparent, highly vinous, and fragrant.

4129. *According to Knight*, after the fermentation has ceased, and the liquor is become clear and bright, it should instantly be drawn off, and not suffered on any account again to mingle with its lees; for these possess much the same properties as yeast, and would inevitably bring on a second fermentation. The best criterion to judge of the proper moment to rack off will be the brightness of the liquor; and this is always attended with external marks, which serve as guides to the cider-maker. The discharge of fixed air, which always attends the progress of fermentation, has entirely ceased; and a thick crust, formed of fragments of the reduced pulp, raised by the buoyant air it contains, is collected on the surface. The clear liquor being drawn off into another cask, the lees are put into small bags, similar to those used for jellies: through these whatever liquor the lees contain gradually filtrates, becoming perfectly bright; and it is then returned to that in the cask, in which it has the effect, in some measure, of preventing a second fermentation. It appears to have undergone a considerable change in the process of filtration.

Its colour is remarkably deep, its taste harsh and flat, and it has a strong tendency to become acetous; probably by having given out fixed and absorbed vital air. Should it become acetous, which it will frequently do in forty-eight hours, it must not on any account be put into the cask. If the cider, after being racked off, remains bright and quiet, nothing more is to be done to it till the succeeding spring; but if a scum collects on the surface, it must immediately be racked off into another cask, as this would produce bad effects if suffered to sink. If a disposition to ferment with violence again appears, it will be necessary to rack off from one cask to another, as often as a hissing noise is heard. The strength of cider is much reduced by being frequently racked off; but this arises only from a larger portion of sugar remaining unchanged, which adds to the sweetness at the expense of the other quality. The juice of those fruits which produce very strong ciders often remains muddy during the whole winter, and much attention must frequently be paid to prevent an excess of fermentation.

4130. *The casks, into which the liquor is put* whenever racked off, should always have been thoroughly scalded, and dried again; and each should want several gallons of being full, to expose a larger surface to the air.

4131. *The above precautions* neglected by the ciderist, the inevitable consequence will be this:—Another fermentation will quickly succeed, and convert the fine vinous liquor he was possessed of into a sort of vinegar; and all the art he is master of will never restore it to its former richness and purity. When the acetous fermentation has been suffered to come on, the following attempts may be made to prevent the ill effects of it from running to their full extent:—A bottle of French brandy, half a gallon of spirit extracted from the lees of cider, or a pailful of old cider, poured into the hogshead soon after the acetous fermentation is begun: but no wonder if all these should fail, if the cider be still continued in a close warm cellar. To give effect to either, it is necessary that the liquor be as much exposed to a cooler air as conveniently may be, and that for a considerable length of time. By such means it is possible fermentation may, in a great measure, be repressed: and if a cask of prime cider cannot thence be obtained, a cask of tolerable second-rate kind may. These remedies are innocent: but if the farmer or cider-merchant attempt to cover the accident, occasioned by negligence or inattention, by applying any preparation of lead, let him reflect, that he is about to commit an absolute and unqualified murder on those whose lot it may be to drink his poisonous draught.

4132. *Stumming*, which signifies the fuming of a cask with burning sulphur, may sometimes be advantageous. It is thus performed:—Take a stripe of canvas cloth, about twelve inches long and two broad; let it be dipped into melted brimstone: when this match is dry, let it be lighted, and suspended from the bung of a cask (in which there are a few gallons of cider) until it be burnt out. The cask must remain stopped for an hour or more, and be then rolled to and fro, to incorporate the fumes of the match with the cider; after which it may be filled. If the stumming be designed only to suppress some slight improper fermentation, the brimstone match is sufficient; but if it be required to give any additional flavour to the cider, some powdered ginger, cloves, cinnamon, &c. may be strewed on the match when it is made. The burning of these ingredients with the sulphur will convey somewhat of their fragrance to the whole cask of cider; but to do it to the best advantage, it must be performed as soon as the vinous fermentation is fully perfected.

4133. *Cider is generally in the best state to be put into the bottle* at two years old, where it will soon become brisk and sparkling; and if it possesses much richness, it will remain with scarcely any sensible change during twenty or thirty years, or as long as the cork duly performs its office.

4134. *In making cider for the common use of the farm-house*, few of the foregoing rules are attended to. The flavour of the liquor is here a secondary consideration with the farmer, whose first object must be to obtain a large quantity at a small expense. The apples are usually ground as soon as they become moderately ripe: and the juice is either racked off at once as soon as it becomes bright, or more frequently conveyed from the press immediately to the cellar. A violent fermentation soon commences, and continues until nearly the whole of the saccharine part is decomposed. The casks are filled up and stopped early in the succeeding spring, and no further attention is either paid or required. The liquor thus prepared may be kept from two to five or six years in the cask, according to its strength. It is generally harsh and rough, but rarely acetous; and in this state, it is usually supposed to be preferred by the farmers and peasantry. When it has become extremely thin and harsh by excess of fermentation, the addition of a small quantity of bruised wheat, or slices of toasted bread, or any other farinaceous substance, will much diminish its disposition to become sour.

4135. *Madeira Cider*. Take new cider from the press, mix it with honey till it bears an egg, boil it gently for a quarter of an hour, but not in an iron pot; take off the scum as it rises, let it cool, then barrel it, without filling the vessel quite full: bottle it off in March. In six weeks afterwards, it will be ripe for use, and as strong as Madeira. The longer it is afterwards kept, the better. (*Mech. Mag.*)

4136. *Perry* is manufactured on exactly the same principles as cider. The pears should not be quite ripe, and the admixture of some wildings will add much to the sprightliness of the taste. "It is thought by some to resemble champagne more than gooseberry wine does; and it is said, when of the best quality, to have been at times sold instead of champagne." (*Lardner's Cyc. Dom. Econ.*)

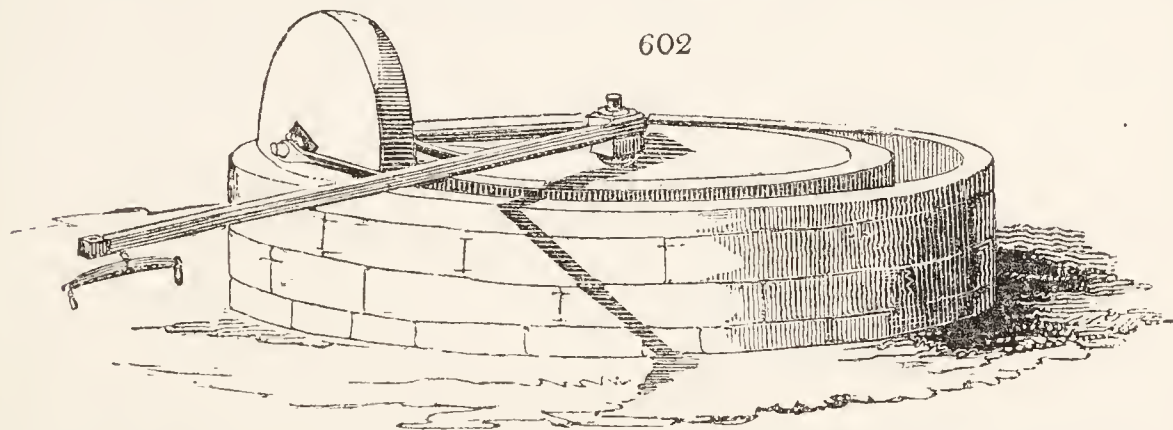
4137. *The produce of cider or perry by the acre* can only be guessed at, by first ascertaining the number of trees. From an orchard of trees in full bearing, half a hogshead of cider may, in seasons ordinarily favourable, be expected from the fruit of each tree. As the number of trees on the acre varies from ten to forty, the quantity of cider must vary in the same proportion, that is, from five to twenty hogsheads. Pear-trees, in equally good bearing, yield fully one third more liquor; therefore, although the liquor extracted from pears sells at a lower price than that produced from apples, yet the value by the acre, when the number of trees is the same, is nearly on a par.

SECT. VI. *Machinery and Utensils necessary for Cider-making.*

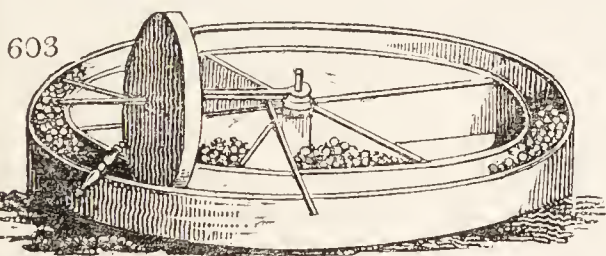
4138. *The machinery of the common ciderist* includes the mill-house, mill, press, cloth, vat, and cask, with their appurtenances.

4139. Marshal, in *The Rural Economy of Gloucestershire*, remarks, that a mill-house, on an orchard-farm, is as necessary as a barn. It is generally one end of an out-building, or perhaps an open shed, under which straw or small implements are occasionally laid up. The smallest dimensions, to render it any way convenient, are twenty-four feet by twenty; a floor thrown over it, at seven feet high; a door in the middle of the front, and a window opposite; with the mill on one side, the press on the other side, of the window, as much room being left in front, towards the door, for fruit and utensils, as the nature of the mill and the press will allow. The utensils belonging to a mill-house are few: the fruit is brought in carts or baskets, and the liquor carried out in pails.

4140. *Of the common cider-mill* there are several varieties, formed on the principles of the bark-mills of tanners. The circle enclosed by the trough is in Devonshire generally in one division (*fig. 602.*), and



is sometimes divided into compartments for containing different varieties of the same fruit. (*fig. 603.*) The size of the runner varies from two and a half to four



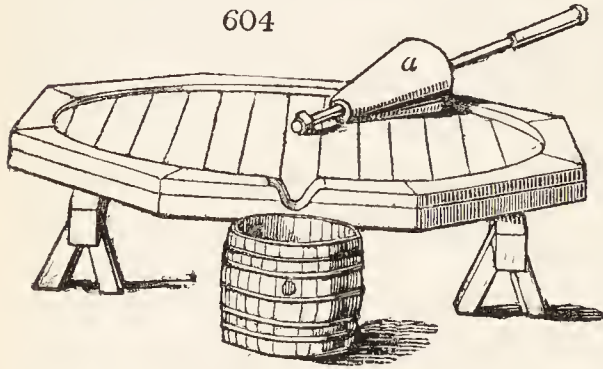
and a half feet in diameter, and from nine to twelve inches in thickness; which in general is equal, like that of a grindstone, not varying, like that of a millstone: the weight one or two tons. The bottom of the chace is somewhat wider than the runner, that this may run freely. The inner side rises perpendicularly, but the outer side spreads, so as to make the top of the trough some six or eight inches wider than the bottom, to give freedom to the runner, and room to scatter in the fruit, stir it up while grinding, and take out the ground matter. The depth is nine or ten inches. The outer rim of the trough is three or four inches wide; and the diameter of the inner circle, which the trough circumscribes, from four and a half to five feet, according to the size of the mill. This is sometimes raised by a table of thick plank fixed upon the stone, with a curb of wood, lessening to an angle, fixed upon the circumference of the trough, making the whole depth of the trough about equal to its width at the bottom. This lessens the quantity of the stone; and the plank upon the centre answers other purposes. The entire bed of a middle-sized mill is about nine feet; some are ten, and some few twelve, in diameter; the whole being composed of two, three, or four stones, cramped together as one; and worked, or at least finished, after they are cramped together. The best stones are raised in the Forest of Dean: they are mostly a dark-reddish gritstone (non-calcareous), working with sufficient freedom, yet sufficiently hard for this intention. The bed of the mill is formed, and the trough partly hollowed, at the quarry, leaving a few inches at the edge of each stone uncut out, as a bond to prevent its breaking in carriage. Much depends on the quality of the stone. It ought not to be calcareous, in whole or in part, as the acid of the liquor would corrode it. Some of the Herefordshire stones have calcareous pebbles in them, which being of course dissolved leave holes in the stone. Nor should it be such as will communicate a disagreeable tinge to the liquor. A clean-grained grindstone grit is the fittest for the purpose.

4141. *The runner*, as it has been seen (*fig. 602.*), is moved by means of an axle passing through the centre, with a long arm, reaching without the bed of the mill, for a horse to draw by; and with a short one passing to an upright swivel, turning upon a pivot, in the centre of the stone, and steadied at the top, by entering a bearing of the floor above. An iron bolt, with a large head, passes through an eye in the lower part of the swivel, into the end of the inner arm of the axis. Thus the requisite double motion is obtained, and the stone kept perfectly upright (which it ought to be) with great simplicity, and without stress to any part of the machine. This is the ordinary method of hanging the runner. There is a more complex way of doing it, but Marshal says he sees no advantage arising from it. There are some mills, it seems, with two runners, one opposite the other. On the inner arm of the axis, about a foot from the

runner, is fixed (or ought to be, though it is frequently wanting) a cogged wheel working in a circle of cogs, fixed upon the bed of the mill.

4142. *The diameter of the wheel* is determined by the height of the axis above the bed of the mill; the diameter of the ring of cogs, by the distance of the wheel from the centre of motion. The use of cog wheels is to prevent the runner from sliding, to which it is liable when the mill is full; the matter, when nearly ground, rising up in a body before the stone. Besides, by assisting the rotatory motion of the stone, it renders the work more easy to the horse. These wheels require to be made with great exactness; and in a country where carpenters are unaccustomed to them, a millwright should be employed in fixing them. The mill is placed so as to leave a horse-path, about three feet wide, between the bed and the walls; so that a moderately sized mill, with its horse-path, takes up a space of fourteen or fifteen feet every way.

4143. *A cider-mill in use in the south of France* (fig. 604.) is worked on a circular platform of boards, and instead of stone the wheel or conical roller (*a*) is of cast-iron. The fruit is spread thinly over the platform, and the roller moved round by one man or a woman. From the roller's covering more breadth than the narrow bark wheels in use in England, more fruit is crushed in a short time by this sort of mill than would at first sight be supposed.



4144. *An eligible description of mill*, where cider is only made for private use, consists of a pair of fluted rollers working into each other. These rollers are of cast-iron, hollow, about nine inches in diameter, with flutes or teeth, about an inch wide, and nearly as much deep. In general they are worked by hand, two men working against each other. Between these the fruit passes twice; the rollers being first set wide to break it into fragments, and afterwards closer to reduce

the fragments and the seeds, the bruising of the latter being of essential use in making high-flavoured cider.

4145. *The apple-mill* is an iron machine. Where iron-mills have been tried, this metal has been found to be soluble in the acid of apples, to which it communicates a brown colour and an unpleasant taste. No combination has been ascertained to take place between this acid and lead; but as the calx of this metal readily dissolves in, and communicates an extremely poisonous quality to, the acetous juice of the apple, it should never be suffered to come into contact with the fruit or liquor. (*Knight on the Apple and Pear.*) In Ireland the cider-mill is composed of two horizontal wooden cylinders, covered with studs of iron like an organ barrel. These work into each other and crush the apples, which are afterwards beat in a vessel with wooden pestles.

4146. *The cider-press* in Herefordshire is a modification of the common screw-press. In Ireland the press bears a considerable resemblance to the common wine-presses of France, that being effected by a long lever which in England is effected by a screw. It will save some subsequent trouble if, in pressing out the juice, the action of the press be applied gradually, and very slowly increased. In this way the juices, at first running muddy, will at length come off perfectly transparent. (*Lardner's Cyclo. Dom. Econ.*)

4147. *Cider cloths* are used for containing the pommage in order to its being pressed. They are usually made of common hair-cloth; but such as is rather close in its texture is the best. The size is generally about four feet square; and they hold about two or three bushels, or as much as the mill can grind at once: and these are heaped over each other till the press is full. The larger presses will hold from eight to fifteen bags, which yield from one to two hundred gallons of liquor, according to the largeness of what is termed the cheese. To perform the work neatly, it is necessary to have two sets of these bags: for they clog and fur in pressing, and consequently become unfit for use till they have been washed and dried; so that, while this is doing, either the press must stand still or another set be ready to employ it. But some, instead of hair bags, lay long straw under the pommage, the ends of which they turn up over it; then cover the pommage entirely with fresh clean straw, upon which they spread another layer of pommage, and so on alternately, till the press is full. Either of the methods will do; but those who are desirous of doing the work in the neatest and best manner generally use bags.

4148. *The cider-vat* is a vessel made for the purpose of receiving the pommage, or the cider before it is racked off into the cask. Vessels of this kind should be made of wood, as where lead is employed it is liable to be corroded by the malic acid.

4149. *Cider casks*, when new, though the wood be ever so well seasoned, are apt to give a disagreeable relish, unless due caution be used before-hand. Frequent scalding with hot water, into which some handfuls of salt have been first thrown, or with water in which some of the pommage has been boiled, and washing afterwards with cider, are the usual remedies against this evil, and seldom fail of removing it effectually. Of old casks, beer-vessels are the worst, as they always spoil cider; and, in return, cider-casks infallibly spoil beer. Wine and brandy casks do very well, provided the tartar adhering to their sides be carefully scraped off, and they are well scalded.

CHAP. XI.

Laying out of Farm and other Culturable Lands.

4150. *The farming lands of an estate* are in general the grand source of its annual rental. The demesne lands are chiefly for enjoyment; the roads afford no direct income; the villages, manufactories, commonly the mines and fisheries, and often also

the woods, yield no income of consequence; but there remain the lands to be let out to the professional farmer, market-gardener, nurseryman, and cottagers: from these the landlord generally derives his principal return for the capital laid out on the estate. Having therefore disposed of all the other parts of the territory, it remains only to arrange the farming or culturable lands in farms of different characters and sizes, in cottage lands, gardens, or orchard grounds: these may be considered in regard to their extent and arrangement.

SECT. I. *Extent or Size of Farm and Cottage Lands.*

4151. *The proper size of farms*, or of land to be let in any way, must necessarily be that which best suits the markets: not altogether the market of the moment, for there may be a run for large or for small farms; but the market on an average of years, times, and circumstances.

4152. *The enlargement or diminution of farms* can proceed only for a time, and to a limited extent. The interest of the landlord, which gave the first impulse, is ever vigilant to check its progress, when it is attempted to carry the measure beyond due bounds. It is in this that the security of the public consists, if it were ever possible that the public interest should be endangered by the enlargement of farms. Accordingly, in most of our counties, a few tenants, of superior knowledge and capital, have been seen to hold considerable tracts of land, which, after a few years, were divided into a number of separate farms. The practice of these men is a lesson to their neighbours; and their success never fails to bring forward, at the expiration of their leases, a number of competitors. Whenever skill and capital come to be generally diffused, there can be few instances of very large farms, if a fair competition be permitted. No individual, whatever may be his fortune and abilities, can then pay so high a rent for several farms, each of them of such a size as to give full room for the use of machinery, and other economical arrangements, as can be got from separate tenants. The impossibility of exercising that vigilant superintendence, which is so indispensable in agricultural concerns, cannot long be compensated by any advantages which a great farmer may possess. His operations cannot be brought together to one spot, like those of the manufacturer; the materials on which he works are seldom in the same state for a few days, and his instruments, animated and mechanical, are exposed to a great many accidents, which his judgment and experience must be called forth instantly to repair.

4153. *If we examine the various sizes of farms in those districts where the most perfect freedom exists*, and the best management prevails, we shall find them determined, with few exceptions, by the degree of superintendence which they require. Hence, pastoral farms are the largest; next, such as are composed both of grazing and tillage lands; then such rich soils as carry cultivated crops every year; and, finally, the farms near large towns, where the grower of corn gradually gives way to the market gardener, cultivating his little spot by manual labour. The hills of the south of Scotland are distributed into farms of the first class; the counties of Berwick and Roxburgh into those of the second; and the smaller farms of the Lothians and of the Carse of Gowrie, where there seems to be no want of capital for the management of large farms, are a sufficient proof of the general principle which determines the size of farms. (*Sup. Encyc. Brit. art. Agr.*)

SECT. II. *Laying out Farms and Farmeries.*

4154. *The arrangement of farms* naturally divides itself into whatever relates to the farmery or home-stall, and what relates to the arrangement of the fields, roads, fences, and water-courses. In a country like Britain, long under cultivation, it is but seldom that these can be brought completely under the control of the improver; but cases occur where this may be done without restraint, as in the enclosure of large commons; and in Ireland and the highlands of Scotland the opportunities are frequent.

SUBSECT. 1. *Situation and Arrangement of the Farmery.*

4155. *The general principles of designing farmeries and cottages* having been already treated of: we have in this place chiefly to apply them to particular cases. Though the majority of farms may be described as of mixed culture, yet there are a number which are almost exclusively devoted to pasture, as mountain farms; to meadow culture, as irrigated or overflowed lands, lands in particular situations, as in fenny districts, and those situated on the borders of some description of rivers: there are others in which peculiar crops are chiefly raised, as in the case of the hop and seed farms of Kent, Essex, and Surrey. All these require a somewhat different kind and extent of accommodation in the farm buildings.

4156. *The requisites for a farmery common to most characters of farms* are, a central situation, neither too high nor too low, shelter, water, exposure to the south or south-

east, in preference to other points ; a level or flat area of sufficient extent for the buildings, yards, and gardens ; grass-land sufficient for one small enclosure or more ; and suitable outlets to the different parts of the farm, and to public roads and markets.

4157. *Some of these requisites may be supplied by art*, as shelter, by plantations ; water, by wells and ponds ; a flat, by levelling ; and grass-lands, by culture : the direction of the roads depends entirely on the designer. But in some cases the situation of the farmery cannot be rendered central, as it frequently happens in the fenny districts of Cambridgeshire, where danger might be incurred from extraordinary floods ; and in the case of mountainous sheep farms, where a central situation might be so elevated as to be deprived of most of the other requisites. Still, even in these cases, the general requisites ought to be attained as far as practicable ; and there are degrees of attainment, as to a central situation, to be arrived at even among fens and mountains.

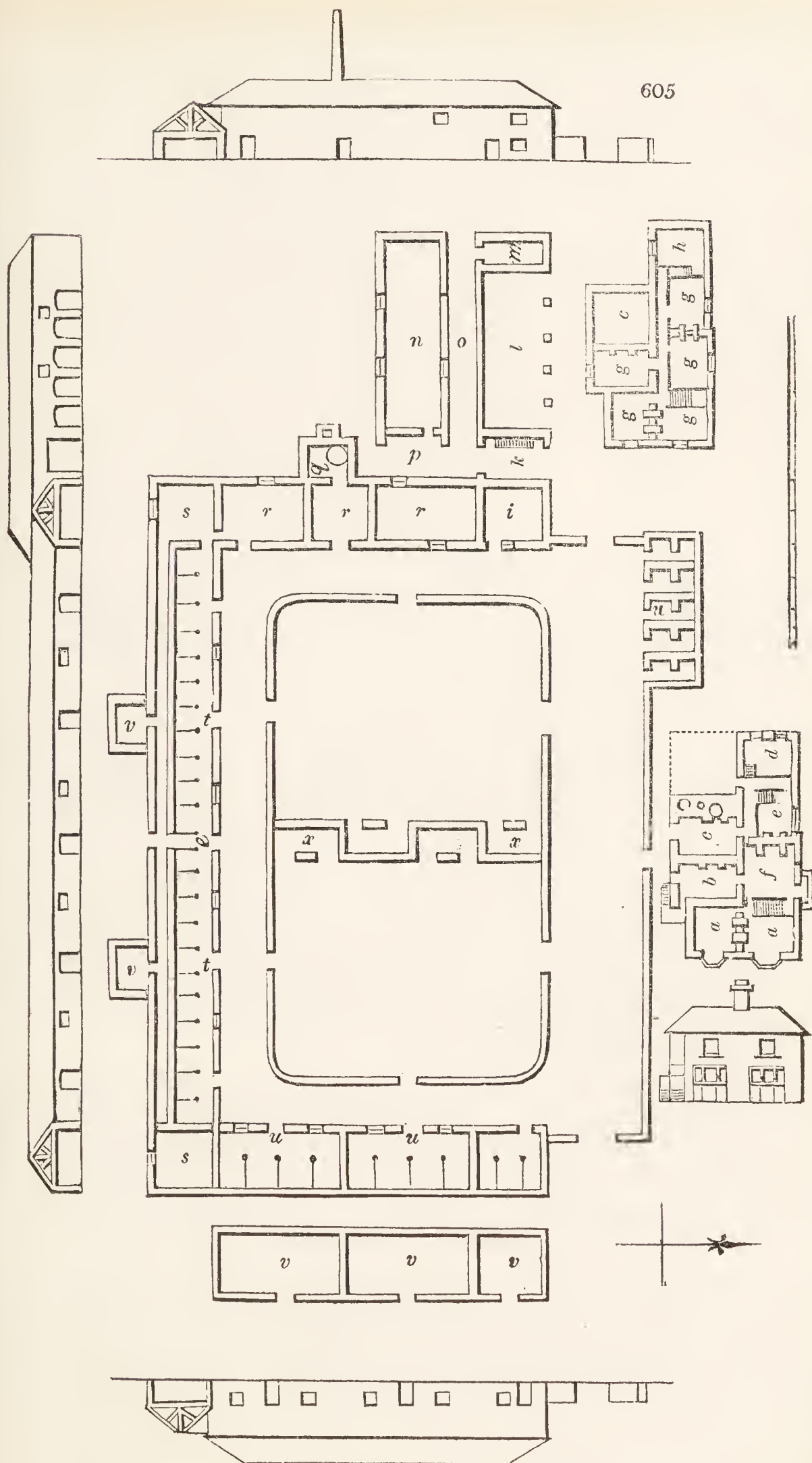
4158. *Excellent examples of different descriptions of farmeries* are to be found in Berwickshire, Northumberland, East Lothian, and on the Marquis of Stafford's estates in Shropshire, Staffordshire, and Sutherland. Besides a great number of cottages and farmeries of different descriptions, thirty-seven new farmeries have been erected by the Marquis of Stafford in Shropshire alone. Loch, Lord Stafford's agent, in describing these (*Account of Improvements on the M. of Stafford's Estates, &c.*), states, that "much attention and consideration have been given to the plans of these buildings, with the view of combining as many advantages as possible, and of arranging the different parts in such a way as to save the time of the tenant and his people, and in order that their extent might be reduced to the least size practicable, securing at the same time the accommodation required. The most approved plans in both ends of the island were consulted, and a gradual improvement has been made on them. The latter ones combine the advantages of the English and Scotch buildings, avoiding, it is hoped, their respective defects. To almost every one of these homesteads is attached a threshing machine, constructed on the best principles : wherever water could be obtained, that has been made use of as the impelling power ; and, of late, some of the more extensive farms have been provided with steam-engines for that purpose."

4159. *In selecting a few of these examples*, the first we shall mention is that of Sidera, or Cider Hall, in Sutherland, erected in 1818. The soil of this farm is of a light and excellent quality, particularly suited to the Norfolk rotation of husbandry, which is followed by Rule, the new tenant, a native of the county of Roxburgh. The house and homestead cost 2200*l.* It is built, in the most sufficient manner, of stone and lime, and covered with Easdale slate, from the west coast of Scotland. In the garden, which is an old one, there are some of the finest holly trees to be met with any where, with several apple, pear, and gean, or small black cherry, trees, of so considerable a size as to show that there is nothing in the climate to prevent the growth of even the more delicate kinds of timber, if not exposed to the sea breeze.

4160. *The accommodations of the house* are, on the ground floor, a parlour, lobby, and staircase, family room, pantry, and kitchen ; behind may be an open yard, and in front a flower-garden ; the chamber story, a bedroom and bedcloset, two bedrooms, maid servant's room, and bedroom. The *offices* contain a cart-house, stable, tool-house, threshing-mill, and straw-house, horse-course, cattle-sheds, dairy, calf-pen, cow-byre, feeding-byre, booth (i. e. booth or lodge) for ploughmen ; pigsties, and poultry above ; paved way, and cattle-yards.

4161. *As an example of a Northumberland farmery* for a farm of from 400 to 500 acres, we have recourse to *The General Report of Scotland*. The accommodations are as follows :— In the dwelling-house are the entrance, stairs to chambers and cellars, and lobby, dining-room, pantry, coal-closet, parlour, business-room, kitchen, back-kitchen, dairy, store-room, poultry, farm-servants' kitchen, boiling-house, root-house, riding-horse stable. In the economical buildings are a cart-shed, straw-barn, and granary over ; corn-barns, hinds, byre for three cows, byre for ten cows, with feeding passage in the centre ; calf-house, loose-horse place, stable, feeding sheds for cattle, with feeding passage along the centre ; pigs, dung-places, straw-yards, cart-shed, and open court. The aspect of the house is south, and the garden and orchard are in front of it.

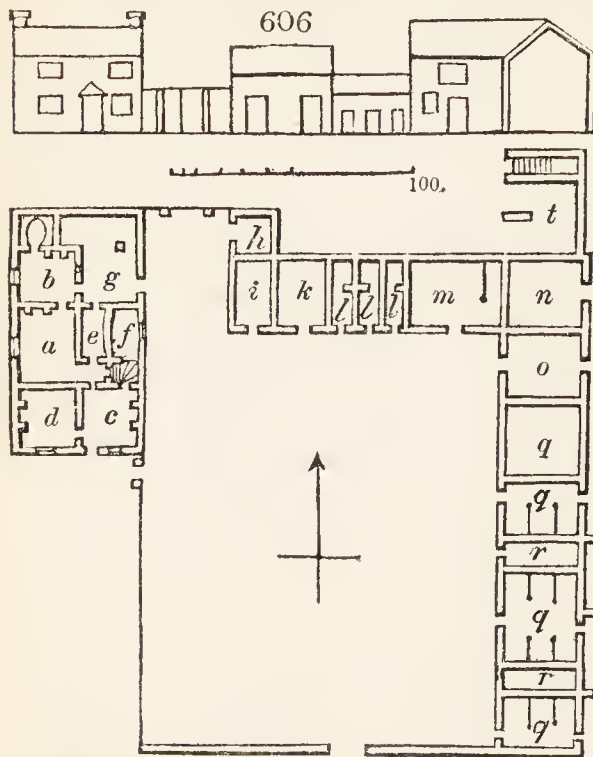
4162. *As an example of a very complete farmery for a turnip and barley soil*, we give that of Fearn (*fig.* 605.), erected by the Marquis of Stafford in the parish of Escall Magna, in Shropshire, in 1820. The farm contains 460 acres of turnip soil ; and the farmery the following accommodations, including a threshing machine driven by steam. In the house are two parlours (*a, a*), family-room (*b*), brew-house, two stories (*c*) ; pantry (*d*), milk-house (*e*), kitchen (*f*), bedrooms (*g*), menservants' bedroom (*h*). In the court offices a hackney-stable (*i*), stair under cover (*k*), waggon-shed and granary over (*l*), tool-house (*m*), cow-house (*n*), places for turnips and straw (*o, p*), steam-engine (*q*), barn (*r*), straw or other cattle-food (*s*), stall-fed cattle (*t*), stables (*u*), turnip-houses (*v*), piggeries, poultry, tools, and necessary (*w*), cattle-sheds to each yard (*x*).



4163. *As an example of a farmery to be managed by a bailiff*, we give that of Skelbo, also in Sutherland. The farm consists of 450 acres, the greater part taken from a heathery waste. It contains a suitable house for the grieve or bailiff, and attached to the office is a threshing machine, combining a corn or meal-mill. Its accommodations

are, a chaff-house, corn-rooms, threshing-mill, with water-wheel and straw-house; cattle-sheds, poultry-houses, and piggery; stables, byres, cart-shed, cattle-shed, dairy, meal-house, lodge for ploughmen, paved way, and cattle-yards.

4164. *As an example of a small farmery in the county of Stafford, we select that of*



Knollwall. (fig. 606.) The extent is 104 acres; the soil is strong and rather wet, and there are some water and other meadows. The house and yard-buildings are of brick and tile, and their accommodations are, a kitchen (a), a brew-house (b), parlour (c), sitting-room (d), pantry (e), milk-house (f), court-yard open (g), coals (h), hackney-stable (i), turkey-house (k), pigsties (l), waggon-horse stable (m), corn-bay (n), barn (o), straw-bay (p), cow-tyings (q), fodder-bins (r), calf-houses (s), and waggon-shed, granary over, connected with barn (t).

4165. *As an example of a middle-sized farmery on a clayey soil, we may refer to that of Newstead, in Staffordshire. This farm contains 314 acres, and the tenant, Ford, is said to be an example to the whole country. The accommodations of the farmery are, in the dwelling-house, an outer kitchen, and kitchen, master's room, brew-house, dairy, pantry, parlour, bedrooms, cheese-room, attics. In*

the court a shed for waggons, with granary over, hackney stable, waggon-horse stable, cattle-sheds, turnip-houses, fodder-house, straw-bays, threshing-mill with water-wheel, corn-bay, tool-house, workshop, bay for unthreshed corn, small granary, and pigsties.

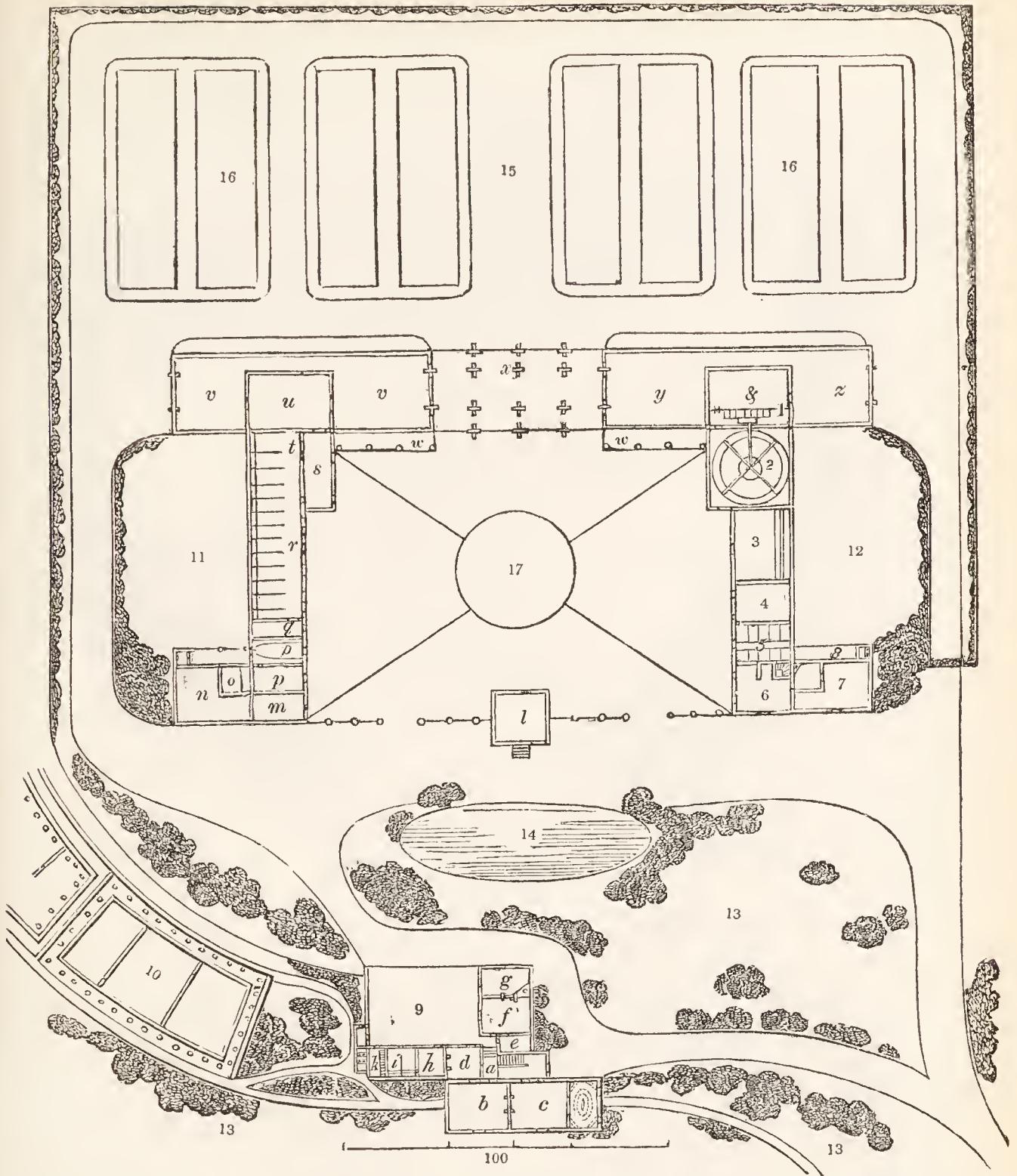
4166. *As an example of an economical farmery for a farm of 50 or 60 acres, we copy from The General Report of Scotland. The accommodations are:— in the house, a kitchen, parlour, store-room, pantry, with three bedrooms, and a light closet over; closet, milk-room, and scullery. In the economical buildings are, a stable with a loose stall, byre for ten cows, cattle-shed, barn, cart-shed, with granary over; pigsties and cattle-yard. This appears one of the most compact and eligible plans for the farmeries of arable farms under 100 acres.*

4167. *As an improved Berwickshire farmery, we submit another specimen from The General Report. Its accommodations are calculated for a farm of 600 acres, and consist, in the dwelling-house range, of a porch, lobby, dining-room, parlour, kitchen, scullery, coal-place, store-room, dairy, pantry, business-room, poultry, steaming-house, bailiff's room. The economical buildings contain a riding-horse stable, tool-house, cart-shed, with granary over; corn-barn, straw-barn, feeding-house for 36 head of cattle, root-house, byre for cows, calf-pens, stable for ten horses, pigs, with yard and troughs, cattle-sheds, dung-basin, and urinarium under; cattle-yards, cart-road paved, rick-yard, mill track, open court, lawn, garden, and orchard.*

4168. *A farmery for a turnip soil of from 600 to 900 acres, from the same work, deserves consideration as a very complete specimen of arrangement. Omitting the farm-house, the economical buildings contain a stable, cow-house, servants' cow, root-house, young horses' stable, straw-barn, corn-barn, stable, cart-shed, place for pickling wheat, killing sheep, or other odd jobs; feeding-house, carpenter's workshop, pigs, geese, common poultry, turkeys, pigs, cattle-sheds, dung and straw courts, with urinariums in the centre of each, paved cart-road round, open court between the yard and dwelling-house, rick-yard, paddocks of old pasture, ponds for drinking and washing the horses' legs.*

4169. *The accommodations for a farm-house, suitable to such a design and to the style of life which the person who can occupy such a farm is entitled to enjoy, are as follows:— In the parlour story there is a lobby, with staircase to chambers and cellars, drawing-room, bedroom, a family work-room, dining-room, business-room, kitchen, barrack-room or manservant's room, store-room, dairy, &c. On the first floor are two best bedrooms, two other bedrooms, bed-closets, another closet, and a water-closet; over are servants' rooms.*

4170. *As a farmery for an arable farm near London of 350 acres (fig. 607.), we shall give as an example one erected (with some variations) in the county of Middlesex, in 1810. It is to be observed, that in Middlesex farming a great object is hay, especially meadow hay, for the London market, which gives rise to the covered spaces for loaded carts (x); it being the custom to load the carts at night, place them under cover, and yoke and go on the road early the following morning. The accommodations of this farmery*

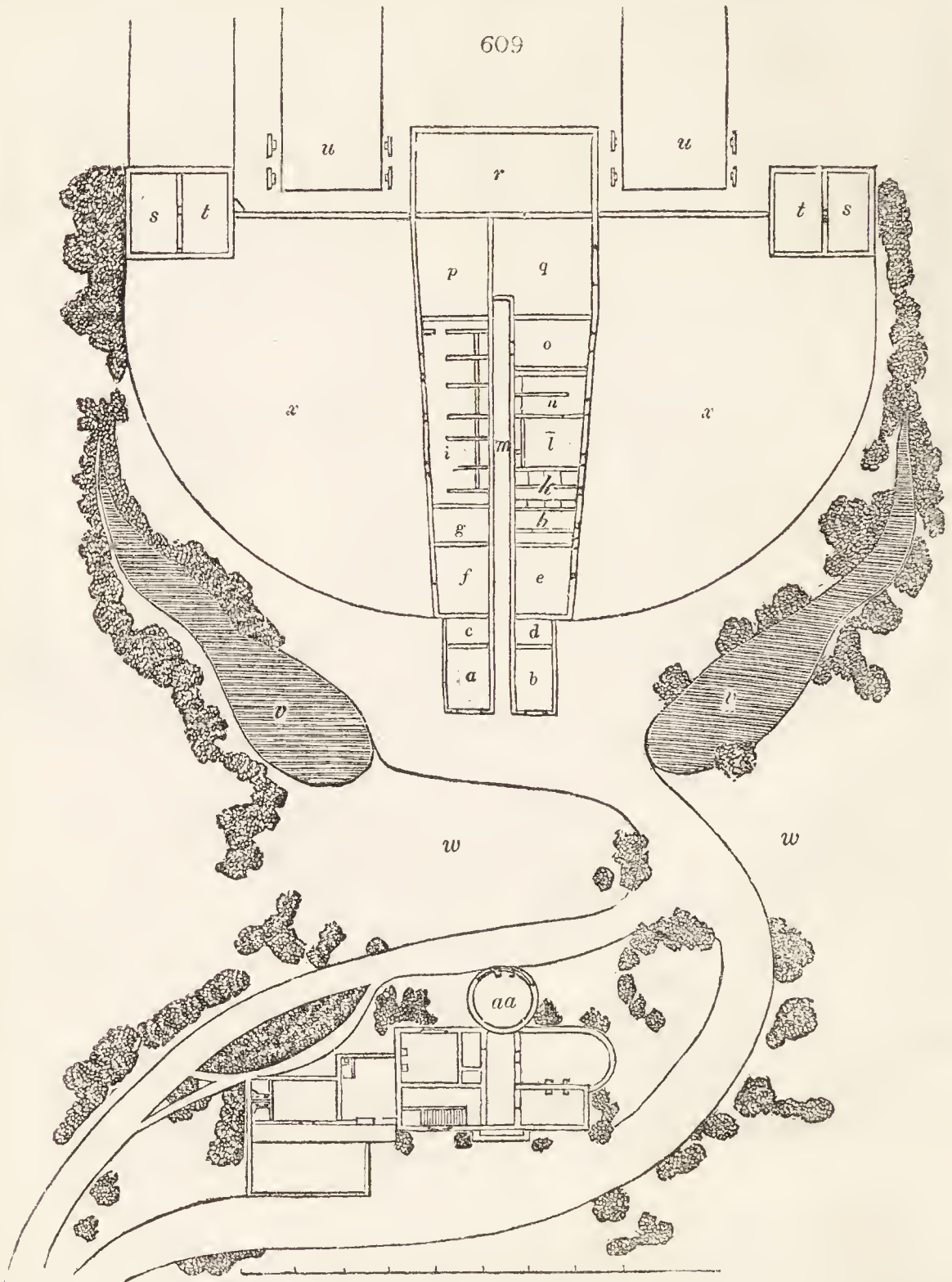


are, in the dwelling-house, a lobby and stair (*a*), dining-room (*b*), drawing-room and green-house (*c*), a housekeeper's room, nursery or butler's pantry (*d*), dairy (*e*), kitchen (*f*), back kitchen and brew-house (*g*), gig-house or coach-house (*h*), small stable (*i*), harness-room and stair to men's room and hay-loft (*k*). In the economical buildings are a granary (*l*), pigs (*m*), carts or odd articles (*n*), water-closet (*o*), poultry (*p*), litter for the stable (*q*), stable for twelve horses (*r*), chaff-room (*s*), litter (*t*), room for cutting hay into chaff (*u*), places for horse food, or straw, hay, &c. (*v*), cattle-sheds (*w*), open colonade for loaded hay-carts (*x*), straw end of barn (*y*), corn-floor (*z*), unthreshed corn and corn-floor (&), machine (1), mill course (2), cows (3), cow-food (4), calves (5), bailiff's house (6), implements (7), wood-house, coals, &c. (8), kitchen-court to master's house (9), garden (10), poultry-yard (11), bailiff's garden (12), lawn, shrubbery, and sheep-walk (13), pond (14), rickyard (15), stack-stands (16), urinarium (17).

4171. In the elevations of this farmery (fig. 608.), some attention has been paid to effect, by intermingling trees, chiefly oaks, with thorns and honeysuckles.



4172. *An anomalous design of a farmery for a hay-farm (fig. 609.), calculated for effect and for inspection from the sitting-room (a, a), contains the following economical buildings:— A poultry-house with granary over (a), a chaise-house with men's room*

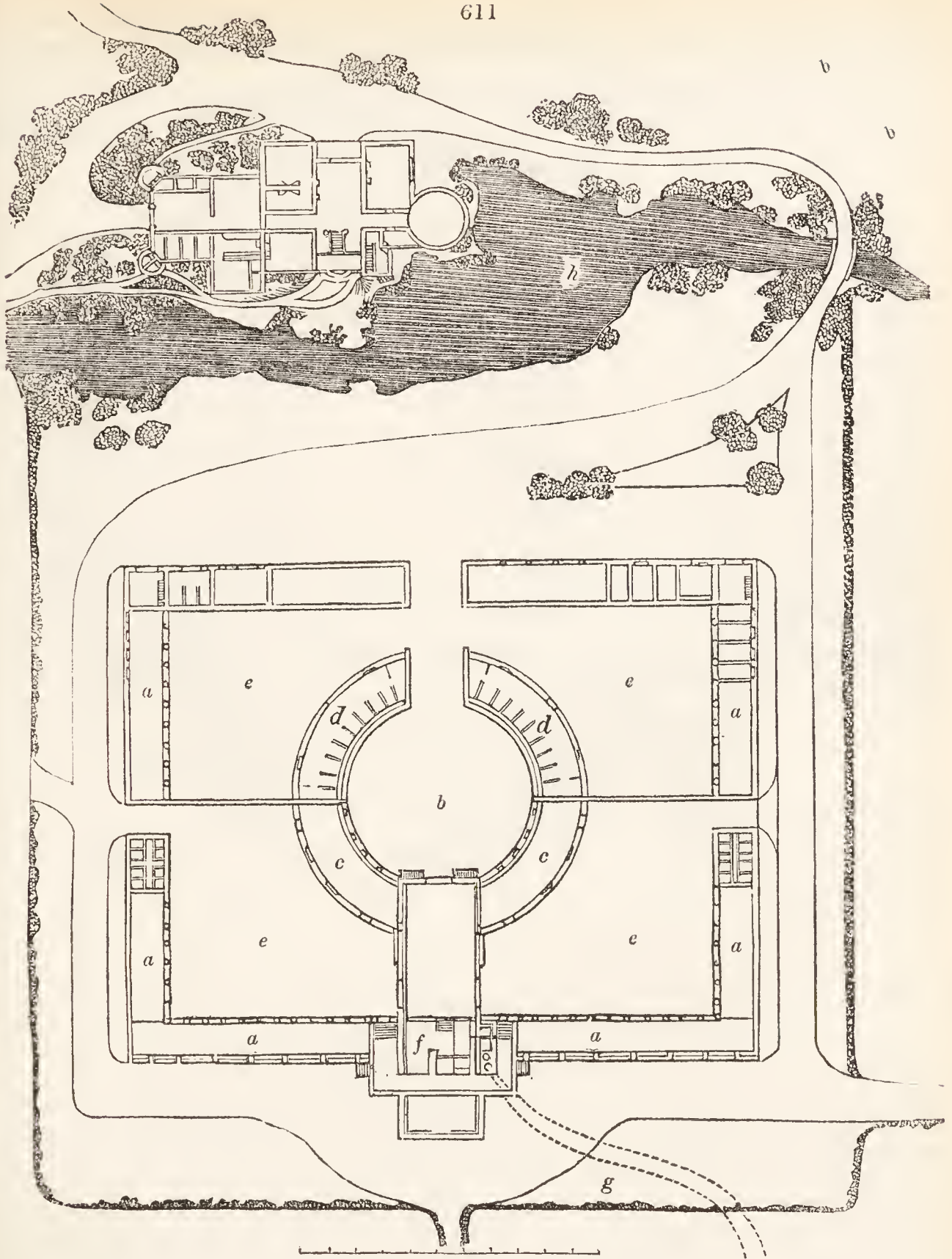


over (b), rabbits (c), tools (d), carts (e), open sheds for carts or other implements (f), sick horse or cow, &c. (g), pigs (h), stable (i), calves (k), cows (l), open passage lighted from above and pump (m), saddle-horse, &c. (n), straw (o), chaff-cutting room (p), hand-threshing-machine (q), unthreshed corn (r), loaded carts of hay (s, t), hay-ricks with roof movable on wheels to protect the hay while binding (u), ponds (v), lawn (w), yard (x). Sitting in the circular room (a, a), the master may look down the light passage which has a wire door, and along the oblique front of the buildings, and see every door that is opened. He may also, as appears by the elevation (fig. 610.) see the men binding hay under the movable covers.

610

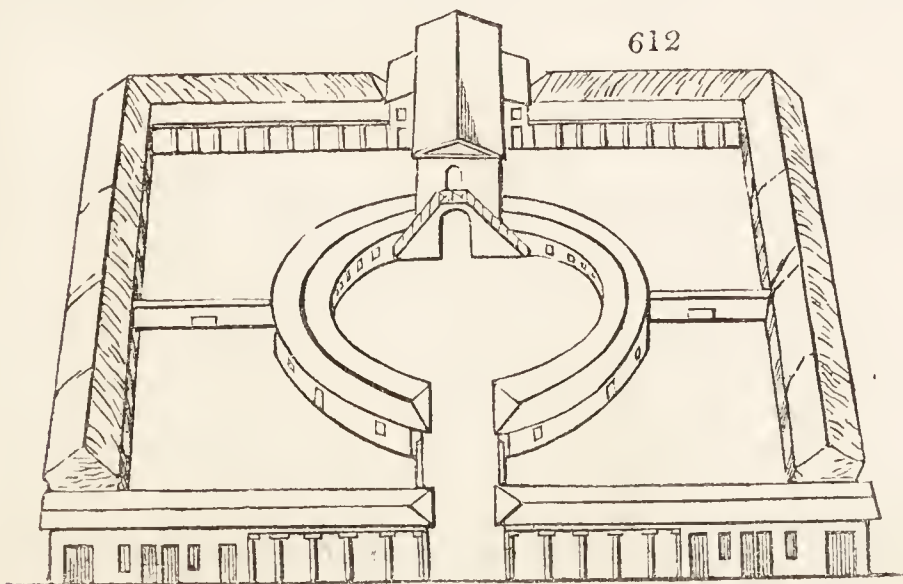


611



4173. An anomalous design for a corn and stall-feeding farm (fig. 611.), in which the stacks are built on the tops of the stables, cattle, and cart-sheds (a), may be noticed, as pleasing in effect, but not likely to be so useful as the more simple plans.

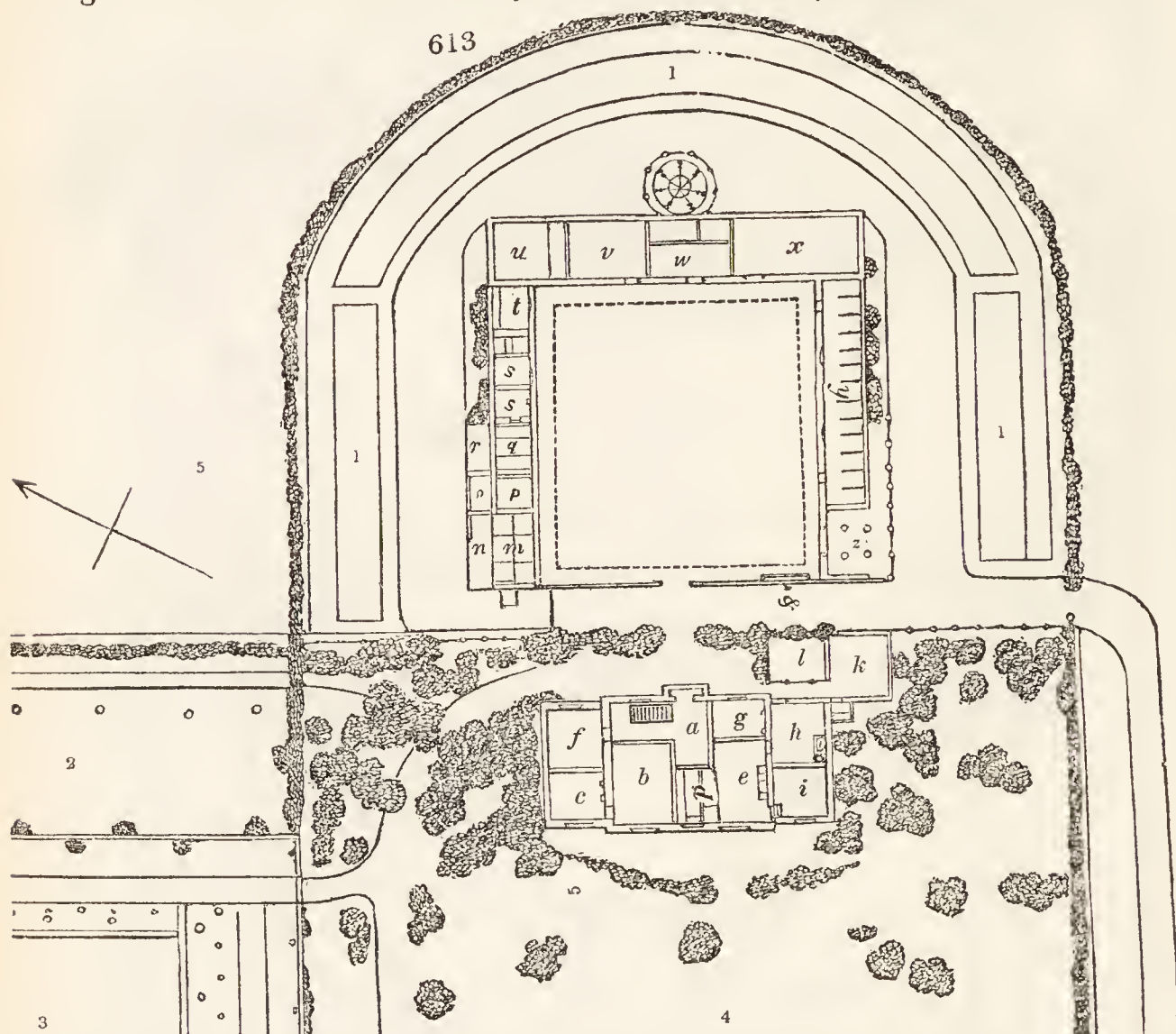
612



The hay, roots, and straw, are stacked in the central circle (b), and very readily supplied to the stable (c), cow-stalls (d), or feeding-yards (e). The threshing-machine (f) is driven by water, which is supplied by a circuitous route (g), from the pond near the house (h). The elevation (fig. 612.) has a good effect when

all the stacks are in their places, and untouched; but as they are removed to the barn the appearance of the flat-roofed sheds will not be so consonant to established notions of beauty and neatness.

4174. *A farmery for a meadow-farm of 250 acres near London (fig. 613.), may be arranged as follows:—*The house may contain a porch, lobby, and stair to chambers and



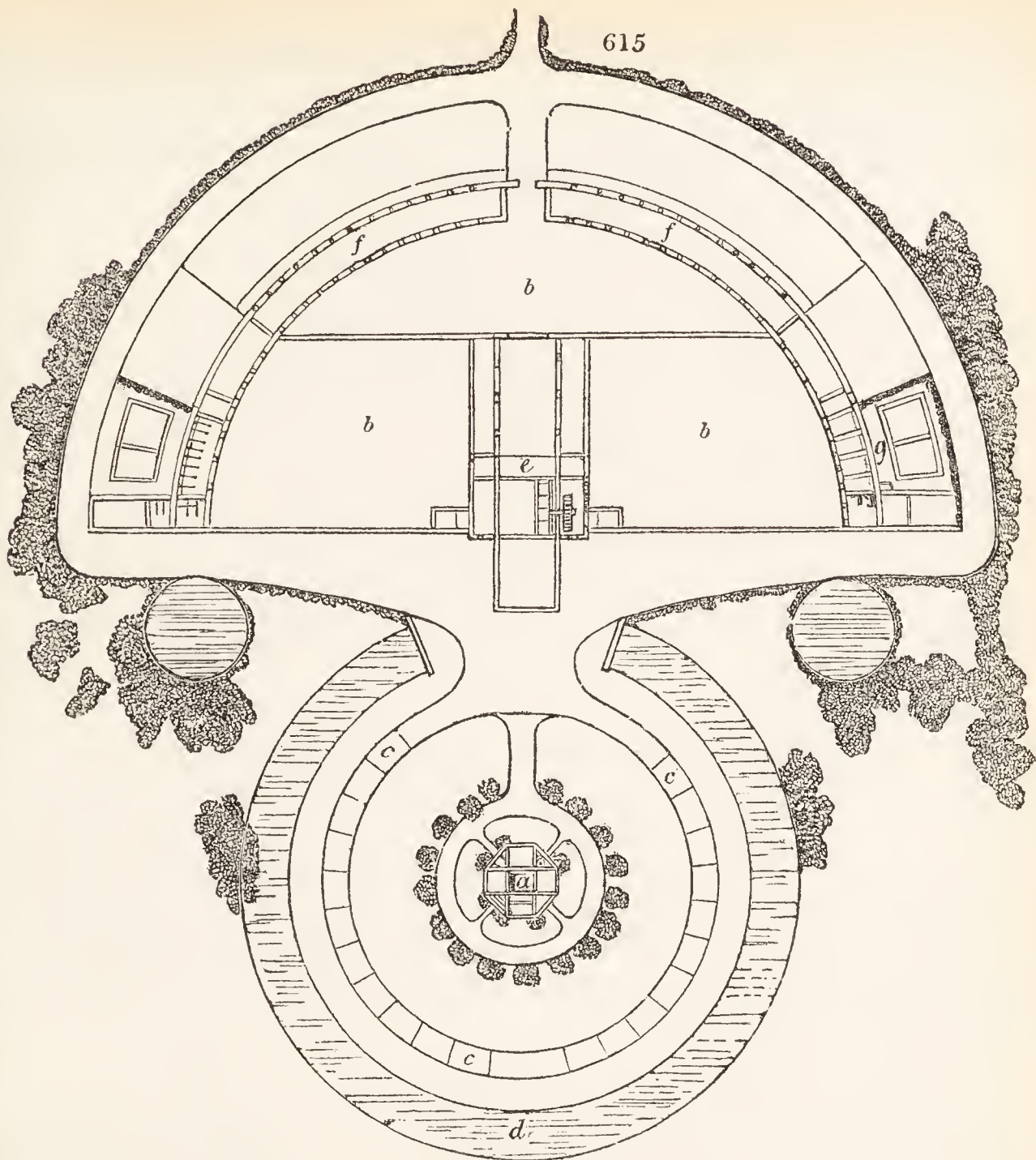
cellars (*a*), parlour (*b*), bedroom or study (*c*), pantry (*d*), kitchen (*e*), lumber-room (*f*), business-room (*g*), back kitchen (*h*), coal cellar and maid's room over (*i*), wood-house (*k*), yard and pump (*l*), pigs (*m*), chaise (*n*), poultry (*o*), tools and roots, &c. (*p*), two stalls, and a saddle and harness place (*q*), harrows and large implements, &c. (*r*), bailiff's house or men's lodge (*s*), cows (*t*), chaff-cutting room, and granary over (*u*), straw-barn (*v*), corn-floor (*w*), unthreshed corn (*x*), stable and stall for litter (*y*), loaded or empty carts and implements (*z*), watering-trough (*y*), rick-stands (1), bailiff's garden (2), master's garden (3), lawn (4), paddock of old grass (5).

4175. *An anomalous design for a turnip-farm of 500 acres (fig. 615.) contains a dwelling-house (a), on an eminence commanding not only the farmery (b), but great part of the farm. It is surrounded by the ricks for shelter (c), and by a pond (d), which drives the threshing-machine (e), and forms a foreground to the distant scenery. There are a large feeding-shed (f), a bailiff's house and garden (g), and the other usual accommodations. The elevation of the feeding-sheds and end of the barn looking towards the house is simple and not inelegant. (fig. 614.)* Farmeries of this sort are not sub-

614



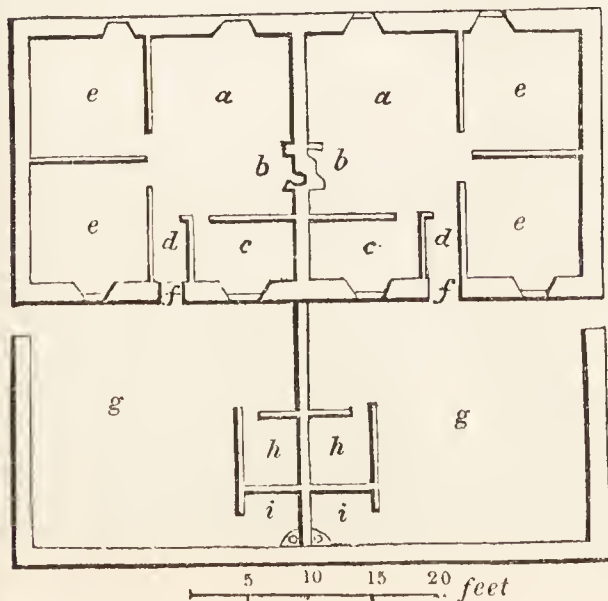
mitted as examples for general imitation, but merely as sources of ideas to such as have the designing of this species of rural buildings, for employers who have a taste for design and for originality, and who can afford to gratify that taste. It is a poor business, and one which never can procure much applause, when a proprietor of wealth and cultivated mind erects for his own use the same sort of farmery, or, indeed, of any other buildings, as the tenants who support him. In East Lothian, Berwickshire, Northumberland, and on the Marquis of Stafford's estates both in England and Scotland, are some noble examples of substantial, commodious, and even elegant farmeries. (See *Gen. Rep. of Scotland*, and *Loch's Imp. on the Marq. of Stafford's Estates*, &c. 8vo. 1819.)



SUBJECT. 2. *Laying out Cottages.*

4176. *Cottage buildings* include a variety of habitations, from the farm-house downwards. On a large estate there will be cottages for tradesmen and mechanics, with and without fields and gardens; others for market-gardeners and nurserymen, surrounded by gardens and orchards; for operative manufacturers; for day-labourers; and, on the farm lands near the farmeries, for ploughmen and herdsmen. The extent of ground which ought to accompany these cottages must be determined entirely by the demand: the regular labourer and ploughman require the least; and the gardener and tradesman, who keep a horse or horses and cow, the most.

616



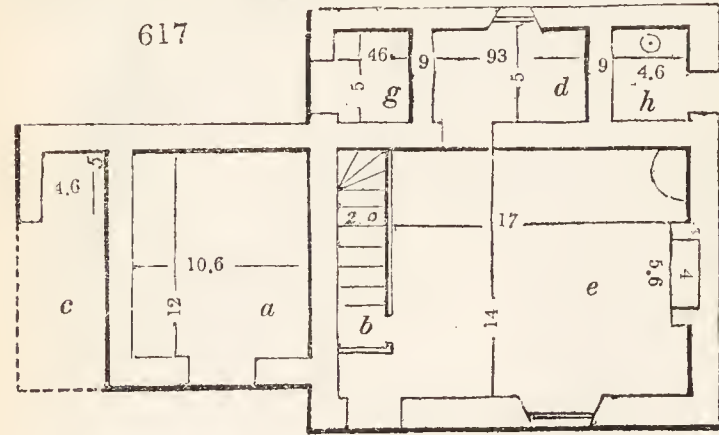
4177. *A cottage fit for a tradesman, mechanic, or bailiff*, given in *The General Report of Scotland*, contains the following accommodations: — A porch, lobby, living-room, two closets with beds, pantry and dairy, fuel and lumber-place, pig, and garden. The cow is kept at the farmery, if for a bailiff; the poultry over the fuel-place, and the bees on stands in the open garden.

4178. *A double cottage of only one floor* (fig. 616.) contains in each, the kitchen (a), with oven (b), pantry and dairy (c), lobby (d), two bedrooms (e, e), entrance door (f), front court-yard (g), pigs (h), necessaries (i). The gardens are at each end, and the cows supposed to be kept at the farmery.

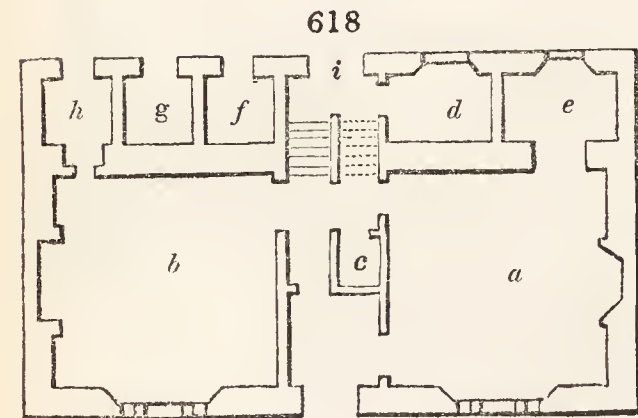
4179. *A cottage on a smaller scale* contains the entrance and stair, parlour and bedroom,

with two good bedrooms over. Behind the main body of the house is a lean-to, containing the kitchen with dairy and pantry, brewing, fuel, and lumber-place. The usual appendages are detached.

4180. A double cottage for two married ploughmen, given in *The General Report of Scotland*, contains a porch, and stair to bedrooms, living-room, pantry and dairy, back kitchen, cow or pig-house, gardens, and two good bedrooms to each.

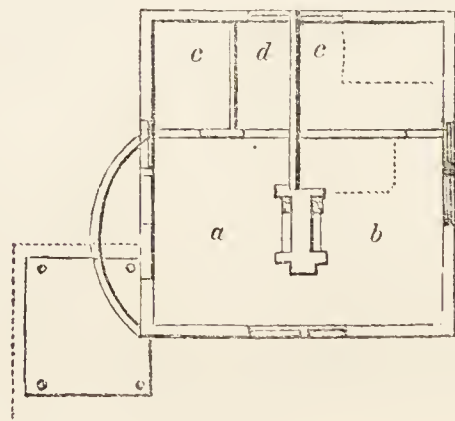
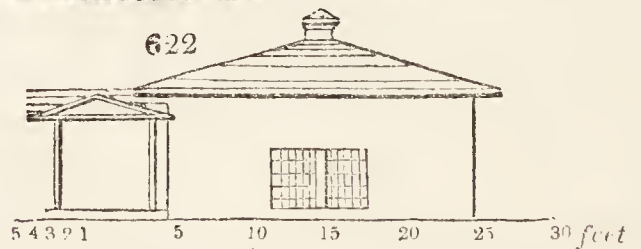
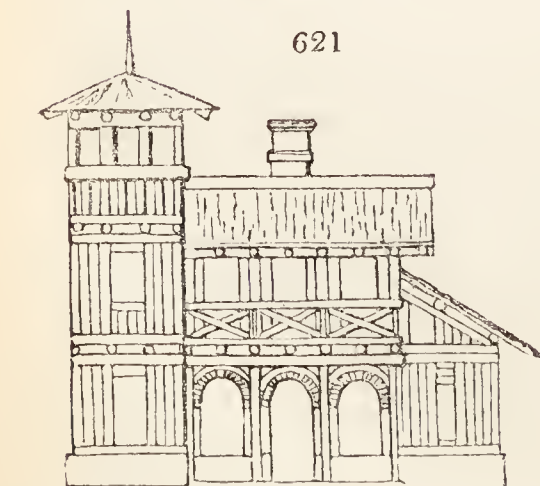
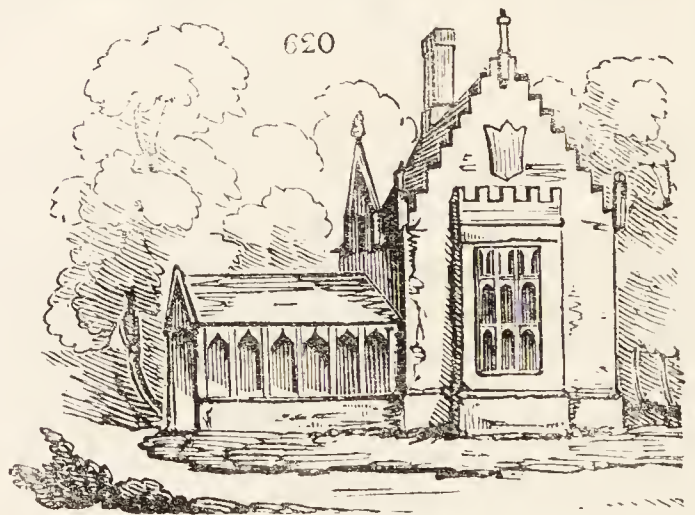
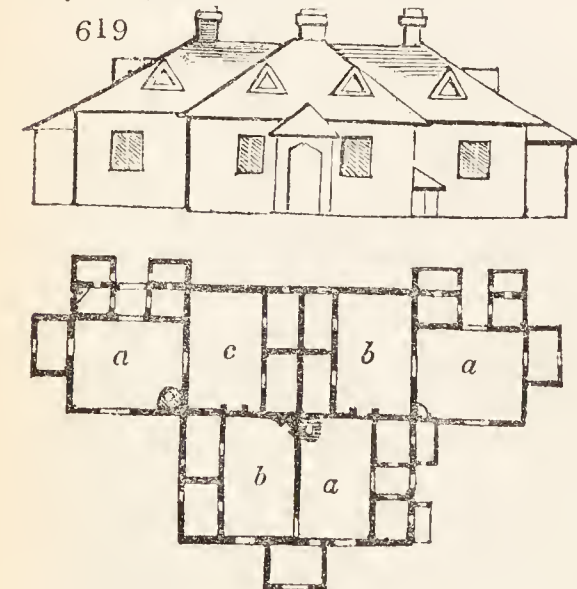


4181. A labourer's cottage with cow-house and piggery (fig. 617.), as commonly constructed in the south of Scotland, is thus arranged:—The cow-house (a) and piggery (c) are in a lean-to. The dwelling contains, on the ground floor, an entrance and stair to bed-garret (b), large kitchen and living-room (e), dairy and pantry (d), coal and wood (g), necessary (h).



4182. A good mechanic's cottage (fig. 618.) is thus arranged:—Parlour (a), kitchen (b), closet (c), dairy and pantry (d), closet to parlour (e), tool-house (f), poultry (g), back entrance to the kitchen and fuel-place (h), back entrance to house and stair (i); over are two good bedrooms, behind is a small court-yard, and the garden surrounds the whole.

4183. Where cottages are erected as picturesque objects, various external forms and styles of design may be adopted, and at the same time the requisite degree of comfort preserved within. Three may be grouped together (fig. 619.) and each have the usual accommodation of kitchen (a) and parlour (b), with the usual closets and garret bedrooms. For cottages of upper servants, on the demesne lands of proprietors, Gothic elevations (fig. 620.), Chinese, Swiss, and Italian (fig. 621.), and every other variety, may be adopted.



4184. For entrance lodges there are many elegant designs by Gandy, Robertson, Papworth, and others; some simple and modern, and others in imitation of the elder styles of building.

4185. A very simple entrance lodge of one story (fig. 621.) may contain a kitchen (a), parlour and bed-room opening into it (b), pantry (c), and closet (d). Towards the road there may either be a bow projection or porch. Detached, in the garden, and concealed by trees and shrubs, may be the usual appendages to comfortable cottages.

SUBSECT. 3. *Laying out the Farm Lands.*

4186. In arranging farm lands, the principal considerations are the size and shape of the fields, and the next the access to them and to the farmery by proper roads.

4187. The form and size of fields have too often been determined without much regard to the size of the farm, the exposure, and the equability of the soil. This is the more to be regretted in the case of live fences, which ought to endure for a long course of years, and which cannot be eradicated without considerable expense. In *The Code of Agriculture* it is observed, that when a whole farm is divided into fields of various sizes, it is difficult to form a plan so as to suit a regular rotation of crops, or to keep very accurate accounts. Whereas, by having the fields in general of a large size, the whole strength of a farm and the whole attention of the farmer are directed to one point; while an emulation is excited among the ploughmen, when they are thus placed in circumstances which admit their work to be compared. Some small fields are certainly convenient on any farm, for grazing and other purposes to be afterwards explained. On elevated situations, also, the shelter derived from small enclosures is of use.

4188. A number of small enclosures, irregularly shaped, surrounded with trees or high hedges, in corn farms, and more especially in corn lands situated in a flat country where shelter is unnecessary, is exceedingly injurious to the farmer. Besides the original expense of making the enclosures, the injury done to the crops of grain, produced by the want of a free circulation of air, and the harbour afforded to numbers of small birds; the very site of numerous hedges, with their attendant ditches, and the uncultivated slips of land on both sides of them, consume a much larger proportion of arable land than is commonly imagined. Hedges, especially if accompanied by rows of trees, greatly exhaust the ground of its fertility, nourish weeds, the seeds of which may be widely disseminated, and, by the exclusion of air, the harvesting of the crop is carried on more slowly. Even upon meadow land, small enclosures encircled by hedges are injurious, as they prevent the circulation of air for making or drying the hay. Small enclosures, with high hedges and trees, are also extremely injurious to the roads in their neighbourhood.

4189. With fields of a considerable size less ground is wasted, and fewer fences are to uphold. The crops of grain, being more exposed to wind, can be harvested earlier, and they suffer less from damp seasons. Small enclosures in pasture are more productive in winter, being better sheltered; but in summer the larger and more open the enclosures are the better; for in hot weather both cattle and sheep always resort to the most airy places. It is easier, also, when they are in pasture, to obtain a supply of water in large fields than in small ones: indeed, fields are sometimes so small, that it is very difficult to procure an adequate supply of water even in winter. But the conclusive argument in favour of large arable fields is this, that where fields are small, much time and labour are wasted by short turnings; and it is now ascertained, "that if fields are of a regular shape, and the ridges of a proper length, five ploughs may do as much work as six ploughs in fields of a small size and of an irregular shape; while every other branch of labour (such as dunging, sowing, harrowing, reaping, and carrying in the harvest,) can be executed, though not altogether, yet nearly, in the same proportion." (*Husb. of Scot.* vol. i. p. 41. and *Sup. Encyc. Brit.* art. Agr.)

4190. The circumstances on which the size of fields ought to depend are, the extent of the farm in which they are situated, the nature of the soil and subsoil, the rotations adopted, the inclination of the ground, its being in pasturage or otherwise, and the nature of the climate. (*Code.*)

4191. *Extent of the farm.* The size of fields ought certainly, in some measure, to depend upon the extent of the possession. In small farms near towns, from six to twelve acres may be sufficient; but where farms are of a considerable extent, fields from twenty to even fifty acres, and, in some particular cases, as high as sixty, may be used to advantage. In general, however, even on large farms, when permitted by local circumstances, fields of a medium size, as from fifteen to twenty-five English acres, are recommended by competent judges.

4192. *Soil and subsoil.* In dividing a farm into fields, the nature of the soil and subsoil ought to be kept in view. Where the soil is various, it would be proper to separate the light from the heavy. They are not only better calculated for different crops and different rotations, but are naturally adapted to be cultivated at different seasons. It is unfortunate, therefore, to have soils of a heterogeneous nature mingled in the same field. But where this partially takes place, for instance, where there is only an acre or two of light soil to ten or twenty of strong soil, let the following plan be adopted:—At any slack time, either in summer or winter, more especially when the field is under fallow, employ two carts and horses with four fillers, to cover the acre or two of light soil, with the strong soil contiguous, and the soil in the field will then become more uniform. In fields where light soils predominate, the plan might be reversed. This plan, though at first expensive, is attended with such advantages that, whenever it is necessary and practicable, it ought to be carried into effect.

4193. *The rotation adopted.* It may be considered as a good general rule, to divide a farm according to the course of crops pursued in it; that is to say, a farm with a rotation of six crops should have six fields, or twelve, according to circumstances. It is proper to have a whole field, if the soil be uniform, under one crop; and every farmer of experience knows the comfort of having the produce of the farm as equal every year as the soil and season will admit of.

4194. *Inclination of the ground.* It is, however, evident that the size of the fields must in some respects depend on the flatness or the hilly shape of the ground. Even on dry land, if there be a rise on the ground, from fifteen to twenty chains is sufficient length; for if the ridge be longer, the horses become much fatigued if compelled to plough a strong furrow up-hill beyond that length in one direction. This objection, however, to large fields, may in some measure be obviated, by giving the ridges and furrows in such fields as are on the sides of a hill, such an obliquity as may diminish the difficulties of the ascent.

4195. *Pasturage.* Where the systems of grazing and tillage alternately is followed (more especially where the fields are pastured for two or three years in succession), it is convenient to have the fields of from twenty to perhaps thirty English acres. The farmer is thus enabled to divide his stock, which he cannot well do with larger fields. The cattle or sheep remain more quiet than if a greater number were collected together, and less grass is destroyed by treading. When such a field has been pastured for some time, the stock should be removed to another, till the grass in the former has renewed, and is fit for being eaten. Such a size also, in general, suits graziers better than larger ones, and consequently fields of this extent, when in pasture, generally let for more rent.

4196. *Climate.* The last circumstance to be considered, in determining the proper size of fields, is the nature of the climate. In dry and cold climates, small enclosures are desirable on account of shelter; whereas, in wet countries, the fields under culture cannot be too open and airy, for the purpose of drying the ground, of bringing forward and ripening the grain, and of enabling the farmer more easily to secure it during an unfavourable harvest, by having a free circulation of air. But, though on large farms fields should in general be formed on an extensive scale, yet there is a convenience in having a few smaller fields near the farm-house for keeping the family cows; for turning out young horses, mares, and foals; for raising a great variety of vegetables; and for trying experiments on a small scale, which may afterwards be extended, if they shall be found to answer. When enclosures are too large for particular purposes, and where no small fields, as above recommended, have been prepared, large fields may be subdivided by sheep-hurdles, a sort of portable fence well known to every turnip-grower. In this way, great advantage may be derived from the constant use of land that would otherwise have been occupied by stationary fences; and the expense of subdivisions, which, on a large farm, would necessarily have been numerous, is thereby avoided. This fence is perfectly effectual against sheep, though it is not so well calculated for stronger animals.

4197. *The shape of fields* may be either square or oblong.

4198. *Square fields.* The advantage of having the fences in straight lines, and the fields, when large, of a square form, is unquestionable, as the ploughing of them under this arrangement can be carried on with much greater despatch. Some farmers, whose fields are of a waving or uneven shape, and who enclose with hedge and ditch, carry their fence through the hollows, or best soil, with a view of raising a good hedge; thus often sacrificing, for the sake of the fence, the form of their field. A straight line, however, is preferable, even though it should be necessary to take some particular pains to enrich the soil for the hedge, where it is thin and poor, on any elevation. By means of the square form, an opportunity is afforded of ploughing in every direction, when necessary; and less time is lost in carrying on all the operations of husbandry in a field of that form than of any other. When the waving form is necessary to secure proper water runs, plantations may be so disposed as to reduce the fields to squares or oblongs, and the fences to straight lines. Rectangular fields have another advantage, that in fields of that shape it may be known whether the ploughmen have performed their duty, the quantity of work done being easily calculated, from the length and breadth of a certain number of ridges.

4199. *Oblong fields.* When fields are small, an oblong shape should be preferred, that the ploughings may be dispatched with as few turnings as possible. This form has also other advantages: the fields are more easily subdivided, and water can in almost every case be got, by making proper ponds in the meeting or joining of three or four fields, whose gutters or ditches will convey water to the ponds. In turnip soils, where the shape is oblong, it is easier to divide the turnips with nets or hurdles, for the convenience of feeding them off with sheep. If the ridges are too long, and the field dry and level, the length may be reduced by making cross head-lands, or head-ridges, at any place that may be considered the fittest by the occupier. (*Code of Agr.* 152 to 157.)

4200. *Hedge-row trees* are very generally objected to by agriculturists. Notwithstanding the garden-like appearance which they give to the landscape, "it seems to be agreed by the most intelligent agriculturists that they are extremely hurtful to the fence, and for some distance to the crops on each side; and it is evident, that in many instances the highways, on the sides of which they often stand, suffer greatly from their shade. It has therefore been doubted whether such trees be profitable to the proprietor, or beneficial to the public; to the farmer they are almost in every case injurious, to a degree beyond what is commonly imagined." (*Supp. to Encyc. Brit.* art. *Agr.*)

4201. *The opinion of Loch*, a well informed and unprejudiced improver of landed property, is of an opposite description. He says: "There is no change in the rural economy of England more to be regretted, than the neglect which is now shown to the cultivation and growth of hedge-row timber. The injury which it does to the cultivation of the land is much exaggerated, especially if a proper selection of trees is made; but even the growth of the ash, so formidable to agriculturists, might be defended, on the ground that without it the best implements employed in the cultivation of the soil could not be made. It is well known that good hedge-row timber is by far the most valuable both for naval and domestic purposes; its superior toughness rendering it equally valuable to the ship-builder and to the ploughwright. The value which it is of in affording shelter is also material: besides, the raising of grain is not the only purpose of life, or the only matter to be attended to, nor the only object worthy of attention. The purposes of war and of national glory, the protection and the extension of our commerce, the construction and repair of buildings, and even the enjoyment arising from the rich and beautiful effect produced by such decoration and ornament, are all objects of material importance to the well-being and constitution of a highly cultivated state of society. Even upon the more narrow basis of individual utility, this practice might be defended and recommended; for it is not useless to consider how many families and estates have been preserved, when pressed by temporary difficulties (from which none are exempted), by a fall of hedge-row timber. One of the best legacies which a great proprietor can leave his country and his family, is an estate well stocked with such trees." Believing, as we do, that there can be no real and permanent beauty that is inconsistent with utility, we prefer, for arable lands, hedges wholly without timber trees. In pasture lands we would rather see the trees in scattered groups than in the hedges; because so placed they are only injurious to the pasture; whereas in the hedge they are injurious to that and the pasture also.

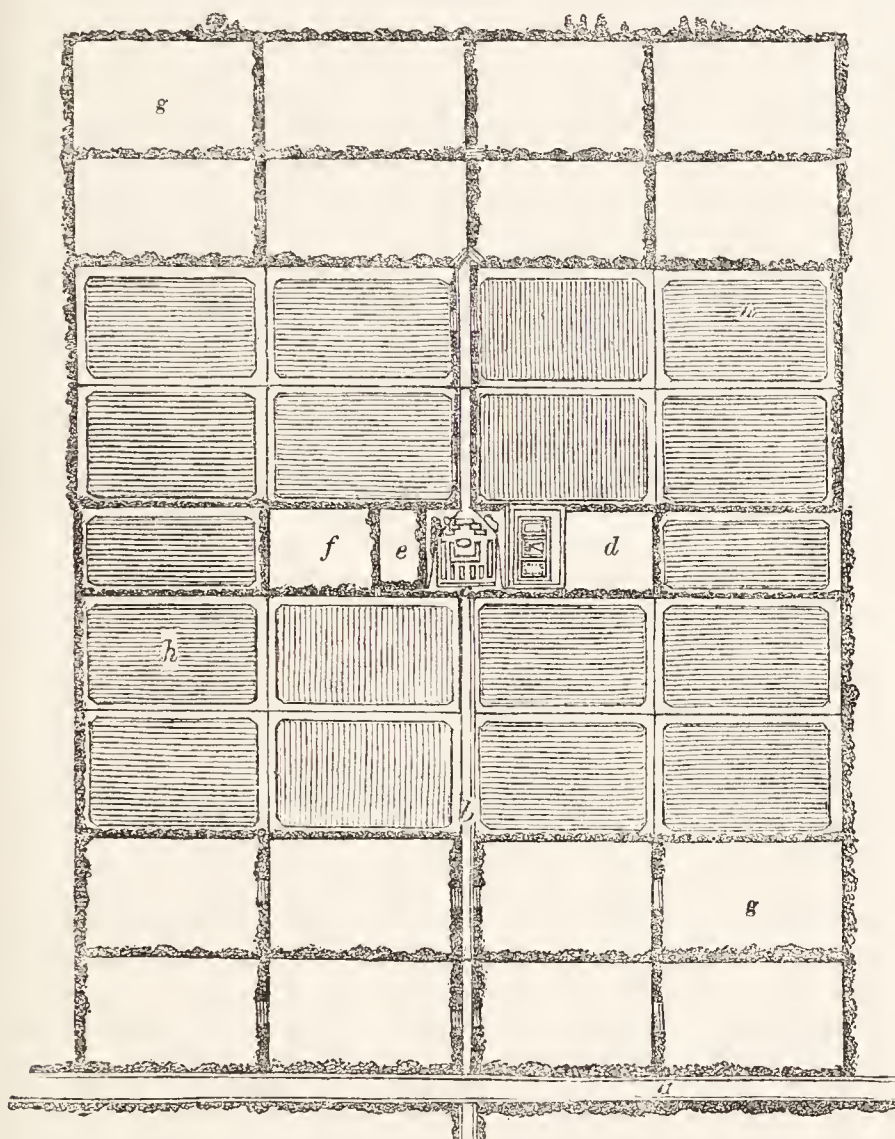
4202. *The gates of fields* should in most cases be placed in the middle of that side of the field which is nearest the road, because, in carting home produce, or in carting out manure, the labour of carting is less on a road than on the soft ground of the field, and because such carting always more or less injures this ground; a part of it along the headlands being necessarily subjected to repetition in the same track; and not in an angle, or at one corner, unless particular circumstances point out this as the preferable mode. Some contend that the gates of fields should be placed in or near the corner next to the road or homestead; but our objection to this arrangement is, that, in carting out manure, or carting home the crop, the headland is liable to be much more severely injured by cart ruts than when the gate is in the middle.

4203. *The drainage and water-courses, if any, on farm lands, require to be attended to in laying out the fences, so as if possible to make the ditches of the latter serve as open drains; also, when opportunity offers, for conveying streams to be used in irrigation, or for driving machinery. The fences and roads will, to a certain extent, be guided by the course of such stream or streams.*

4204. *As an example of laying out farm lands from a newly enclosed common, we submit the case of a flat surface, a strong retentive clay soil, a moist climate, a situation distant from markets, with no other object in view than that of making as much of the lands as possible.*

4205. *A public road (fig. 623. a) passes the farm, and the farmery is approached by a private road (b).*

623



The size of the farm deemed proper is 350 acres; the most profitable mode of occupation is, 180 in arable, and the remainder in pasture. The arable subjected to a rotation of 1st, beans drilled, or naked fallow dunged; 2d, wheat; 3d, clover and rye-grass, fed off or mown for soiling cattle; 4th, wheat or oats, if the clover was mown, dunged. The grass-lands are supposed to be wholly fed off, chiefly with cattle, but also with ten cows, for butter and breeding, and a few sheep.

4206. *The buildings (c) are placed in the centre of the farm, and contain stabling for four work-horses, and open sheds for eight oxen; 130 feet of sheds for thirty fattening cattle; a barn, with threshing-machine impelled by wind; houses for ten cows, and other conveniences in proportion. There is a kitchen-garden, orchard, rick-yard, and two paddocks (d, f), adjoining the farmery.*

4207. *The grass-fields (g), contain only ten acres each, to admit of the great advantage of shifting the stock from one to another. They are most distant from the farmery, because requiring least cartage; and, some of them being in the lowest part of the farm, they may be irrigated. Trees are avoided in the fences, as injurious in flat surfaces and adhesive soils. For the purposes of shading cattle, one or two might be planted in the angles of the field; but a temporary shed of the rudest and slightest materials, and easiest taken down, removed, and reconstructed, is preferable, as calculated to distribute the manure produced by the cattle when at rest.*

4208. *The arable lands (h) are preserved in the centre, to save carting to and from the farmery; and the enclosures are four times the size of the grass-fields, each shift forming one large enclosure, containing four fields, divided only by open ditches for carrying off the surface water. The two small central fields shown under aration, are supposed alternately in turnips, potatoes, cabbages, &c. for cows, &c. and wheat. The paddocks and closes are for calves or colts.*

4209. *The chief, and almost sole, products of this farm will be wheat and beef: the former best worth sending to a distant market; the latter easily transported to any distance; and both staple commodities.*

4210. *With respect to roads, sometimes a farm is situated on both sides of a highway; in which case all the fields may be made to open into it, either directly or through an intervening field. Hence no private road is wanting, excepting a few yards to reach the farmery. But when, as is most generally the case, the lands are situated at a distance from a great road, and approached by a lane or by-road, then from that by-road a private road is required to the farmery, and a lane or lanes from it so contrived as to touch at most of the fields of the farm. In wet and clayey soils, these lanes must be formed of durable materials; but in dry soils, provided attention be paid to fill in the cart ruts as they are formed (by the leading out of dung, or home of corn), with small stones, gravel or even earth, the lane may remain green; and, being depastured by sheep or cattle, will not be altogether lost. It is essentially necessary to make a piece of road at the gate of every enclosure, that being the spot which is most frequently in use. Without this precaution, it often becomes a mire where corn is thrown down and spoiled in harvest, or, if it is attempted to avoid the mire, the gate-posts and neighbouring fence are often damaged. (Communications to the Board of Agriculture, vol. ii. p. 251.)*

4211. *With good private roads* a farmer will perform his operations at much less expense; the labour of the horses will be much easier; a greater quantity or weight of grain and other articles may be more expeditiously carried over them; manure can be more easily conveyed to the fields; the harvest can be carried on more rapidly; and wear and tear of every description will be greatly reduced. (*Code of Agriculture*, p. 158.)

BOOK III.

OF IMPROVING THE CULTURABLE LANDS OF AN ESTATE.

4212. HAVING completed the general arrangement of an estate, the next thing is to *improve the condition of that part of it destined to be let out to tenants*, which, as already observed, constitutes the chief source of income. The farm lands being enclosed and subdivided, and the farmeries and cottages built in their proper situations, in many cases no other improvements are wanted on the soil than such as are given by the tenant in the ordinary course of culture. But there are also numerous cases, in which improvements are required which could not be expected from an occupier having only a temporary interest in his possession; and these form the present subject of discussion. Such improvements are designated by agriculturists *permanent*, as conferring an increased purchasable value on the property, in opposition to improvements by a temporary occupier, the benefits of which are intended to be reaped during his lease. The latter class of improvements includes fallows, liming, marling, manuring, improved rotations, and others of greater expense, according to the length of lease, rent, and encouragement given by the landlord: the former, which we are now about to discuss, includes draining, embanking, irrigating, bringing waste lands into cultivation, and improving the condition of lands already in a state of culture.

CHAP. I.

Draining Watery Lands.

4213. *Draining* is one of those means of improvement, respecting the utility of which agriculturists are unanimous in opinion. Though practised by the Romans (143.), and in all probability in some cases by the religious fraternities of the dark ages, it was not till after the middle of the last century that its importance began to be fully understood in Britain; and that some individuals, and chiefly Dr. Anderson and Elkington, began to practise it on new principles. About the same time, the study of geology became more general, and this circumstance led to the establishment of the art on scientific principles. The public attention was first excited by the practice of Elkington, a farmer and self-taught professor of the art of draining in Warwickshire and the adjoining counties. On the practice of this artist most of the future improvements have been founded; and they have been ably embodied in the account of his practice by Johnston, from whose work we shall draw the principal materials of this section, borrowing also from the writings of Dr. Anderson, Marshal, Smith, Farey, Stephens, and some others on the same subject, and from the sixth and seventh volumes of the *Highland Society's Transactions*. After submitting some general remarks on the natural causes of wetness in lands, we shall consider in succession the drainage of boggy lands, hilly lands, mixed soils, retentive soils, and mines and quarries; and then the kinds of drains, and draining materials.

SECT. I. *Natural Causes of Wetness in Lands, and the general Theory of Draining.*

4214. *The successful practice of draining* in a great measure depends on a proper knowledge of the structure of the earth's upper crust, that is, of the various strata of which it is composed, as well as of their relative degrees of porosity, or capability of admitting or rejecting the passage of water through them, and likewise of the modes in which water is formed, and conducted from the high or hilly situations to the low or level grounds. In whatever way the hills or elevations that present themselves on the surface of the globe were originally formed, it has been clearly shown, by sinking large pits, and digging into them, that they are mostly composed of materials lying in a stratified order, and in oblique or slanting directions downwards. Some of these strata, from their nature and properties, are capable of admitting water to percolate or pass through them; while others do not allow it any passage, but force it to run or filtrate along their surfaces without penetrating them in any degree, and in that way conduct it to the more level grounds below. There it becomes obstructed or dammed up by meeting with impervious materials of some kind or other, by which it is readily forced up into the superincumbent layers where they happen to be open and porous, soon rendering them too wet for the purposes

of agriculture ; but where they are of a more tenacious and impenetrable quality, they only become gradually softened by the stagnant water below them ; by which the surface of the ground is, however, rendered equally moist and swampy, though somewhat more slowly than in the former case. It may also be observed, that some of the strata which constitute such hilly or mountainous tracts are found to be continued with much greater regularity than others ; those which are placed nearest to the surface, at the inferior parts of such hills or elevations, being mostly broken or interrupted before they reach the tops or higher parts of them ; while those which lie deeper, or below them at the bottom, show themselves in these elevated situations. Thus, that stratum which may lie the third or fourth, or still deeper, at the commencement of the valley may form the uppermost layer on the summits of hills or mountainous elevations. This arrangement or distribution of the different strata may have been produced partly by the circumstances attending the original elevation of such mountainous regions, and partly from the materials of the original exterior strata being dissolved and carried down into the valleys by successive rains and other causes, and thus leaving such as were immediately below them in an exposed and superficial state in these elevated situations. (*Darwin's Phytologia*, p. 258.)

4215. *These elevated strata frequently prove the means of rendering the grounds below wet and swampy* ; for the general moisture of the atmosphere being condensed in much greater quantities in such elevated situations, the water thus formed, as well as that which falls in rain and sinks through the superficial porous materials, readily insinuates itself, and thus passes along between the first and second or still more inferior strata which compose the sides of such elevations, until its descent is retarded or totally obstructed by some impenetrable substance, such as clay : it there becomes dammed up, and ultimately forced to filtrate slowly over it, or to rise to some part of the surface, and constitute, according to the particular circumstances of the case, different watery appearances in the grounds below. These appearances are, oozing springs, bogs, swamps, or morasses, weeping rocks from the water slowly issuing in various places, or a large spring or rivulet from the union of small currents beneath the ground. This is obvious from the sudden disappearance of moisture on some parts of lands, while it stagnates, or remains till removed by the effects of evaporation, on others ; as well as from the force of springs being stronger in wet than in dry weather, breaking out frequently after the land has been impregnated with much moisture in higher situations, and as the season becomes drier ceasing to flow, except at the lowest outlets. The force of springs, or proportion of water which they send forth, depends likewise, in a great measure, on the extent of the high ground on which the moisture is received and detained, furnishing extensive reservoirs or collections of water, by which they become more amply and regularly supplied. On this account, what are termed bog-springs, or such as rise in valleys and low grounds, are considerably stronger and more regular in their discharge, than such as burst forth on the more elevated situations or the sides of eminences. (*Johnston's Account of Elkington's Mode of Draining Land*, p. 15.)

4216. *The waters condensed on elevated regions* are sometimes found to descend, for a very considerable distance, among the porous substances between the different conducting layers of clayey or other materials, before they break out or show themselves in the grounds below ; but they are more frequently found to proceed from the contiguous elevations into the low grounds that immediately surround them.

4217. *The nature of the stratum of materials on which the water descending from hills has to proceed* must considerably influence its course, as well as the effects which it may produce on such lands as lie below, and into which it must pass. Where the stratum is of the clayey, stiff marly, or impervious rocky kind, and not interrupted or broken by any other materials of a more porous quality, the water may pass on to a much greater distance, than where the stratum has been frequently broken and filled up with loose porous materials, in which it will be detained, and of course rise up to the surface.

4218. *These sorts of strata extend to very different depths in different situations and districts*, as it has been frequently noticed in the digging of pits, and the sinking of deep wells, and other subterraneous cavities. The clayey strata are, however, in general found to be more superficial than those of the compact, tenacious, marly kind, or even those of a firm, uninterrupted, rocky nature, and seldom of such a great thickness ; they have, nevertheless, been observed to vary greatly in this respect, being met with in some places of a considerable thickness, while in others they scarcely exceed a few inches.

4219. *The intervening porous substances, or strata, where clay prevails, are found, for the most part, to be of either a gravelly or loose rocky nature.* Stiff marly strata, which approach much to the quality of clay, though in some instances they may present themselves near the surface, in general lie concealed at considerable depths under the true clayey strata, and other layers of earthy or other materials ; they have been discovered of various thicknesses, from eight or ten feet to considerably more than a hundred. (*Darwin's Phytologia*, p. 259.) The intervening materials, where strata of this nature predominate, are most commonly of the more sandy kinds ; possessing various degrees

of induration, so as in some cases to become perfectly hard and rocky, but with frequent breaks or fissures passing through them. The loose, friable, marly strata are capable of absorbing water, and of admitting it to filtrate and pass through them.

4220. *Thus the valleys and more level grounds must constantly be liable to be overcharged with moisture, and to become, in consequence, spouty, boggy, or of the nature of a morass, accordingly as they may be circumstanced in respect to their situation, the nature of their soils, or the materials by which the water is obstructed and detained in or upon them.*

4221. *Where lands have a sufficient degree of elevation to admit of any over-proportion of moisture readily passing away, and where the soils of them are of such a uniform sandy or gravelly and uninterrupted texture, as to allow water to percolate and pass through them with facility, they can be little inconvenienced by water coming upon or into them, as it must of necessity be quickly conveyed away into the adjacent rivers or small runlets in their vicinity.*

4222. *But where grounds are in a great measure flat, and without such degrees of elevation as may be sufficient to permit those over-proportions of moisture that may have come upon them from the higher and more elevated grounds to pass readily away and be carried off, and where the soils of the lands are composed or constituted of such materials as are liable to admit and retain the excesses of moisture; they must be exposed to much injury and inconvenience from the retention and stagnation of such quantities of water. Such lands consequently require artificial means to drain and render them capable of affording good crops, whether of grain or grass.*

4223. *Lands of valleys and other low places, as well as, in some cases, the level tracts on the sides or borders of large rivers and of the sea, must also frequently be subject to great injury and inconvenience from their imbibing and retaining the water that may be thus forced to flow up into or upon them, either through the different conducting strata from the hills and mountainous elevations in the neighbourhood, or the porous materials of the soils. In these ways they may be rendered swampy, and have bogs or morasses produced in them in proportion to the predominancy of the materials by which the water is absorbed and dammed up, and the peculiarity of the situation of the lands in respect to the means of conveying it away.*

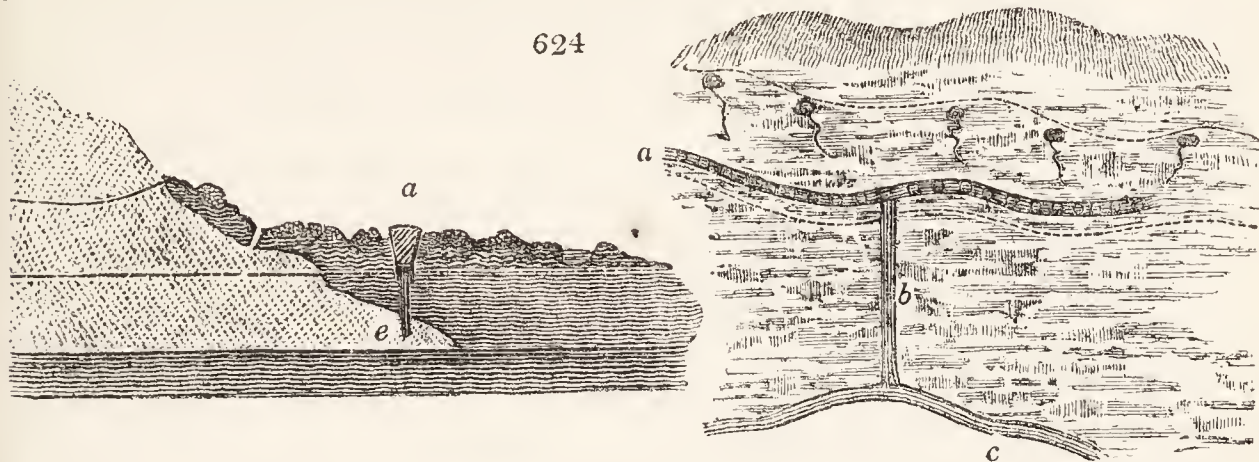
4224. *To perform properly the business of draining, attention should not only be paid to the discrimination of the differences in regard to the situation of the lands, or what is commonly denominated drainage level; but also to the nature, distribution, and depth of the materials that constitute the soils or more superficial parts of them, as upon each of these some variety, in respect to the effects arising from water retained in them, may depend.*

4225. *The general origin of that wetness of land which it is the object of under-draining to remove, "will be found to be the existence of water in substrata of sand, gravel, open rock, or other porous substances, which either lead to the surface, or, having no natural outlet, become filled or saturated, while the pressure of more water coming from a higher source, forces that which is in the lower part of the stratum upwards through the superior strata to the surface; thus occasioning either bursts and springs, or a general oozing through the soil. The object in under-draining, therefore, is not to catch the surface-water, but that which flows through their inferior strata; and, for this purpose, it is necessary to make a sufficient channel, either at the lower parts of the porous stratum, or in such part of it as may most conveniently carry off the water, so as the pressure referred to may be relieved, or the water intercepted before it reaches the surface. It must always be kept in mind, then, that under-draining and surface-draining are operations essentially distinct; and every care must be used in practice not to blend them in the execution. If surface-water be allowed to get into covered drains, the sand and mud which it will carry into these subterraneous channels will soon choke them up, and occasion bursts, creating, as may be conceived, new swamps; while the expense of taking up and relaying the under-drains will be very great, and the execution imperfect, the sides being found never to stand a second time so well as when first formed." (Highland Society's Trans. vol. vii. p. 218.)*

4226. *Wetness of land, so far as it respects agriculture, and is an object of draining, may generally depend on the two following causes: first, on the water which is formed and collected on or in the hills or higher grounds, filtrating and sliding down among some of the different beds of porous materials that lie immediately upon the impervious strata, forming springs below and flowing over the surface, or stagnating underneath it; and, secondly, on rain or other water becoming stagnant on the surface, from the retentive nature of the soil or surface materials, and the particular nature of the situation of the ground. The particular wetness which shows itself in different situations, in the forms of bogs, swamps, and morasses, for the most part proceeds from the first of these causes; but that superficial wetness which takes place in the stiff, tenacious, clayey soils, with little inclination of surface, generally originates from the latter.*

4227. *The most certain and expeditious method of draining, in such cases, is that of*

intercepting the descent of the water or spring, and thereby totally removing the cause of wetness. This may be done where the depth of the superficial strata, and consequently of the spring, is not great; by making horizontal drains (*fig. 624. a*) of consi-



derable length across the declivities of the hills, about where the low grounds of the valleys begin to form, and connecting these with others (*b*) made for the purpose of conveying the water thus collected into the brooks or runlets (*c*) that may be near. Where the spring has naturally formed itself an outlet, it may frequently only be necessary to bore into it (*e*), or render it larger, and of more depth; which, by affording the water a more free and open passage, may evacuate and bring it off more quickly, or sink it to a level so greatly below that of the surface of the soil, as to prevent it from flowing into or over it.

4228. Where the uppermost stratum is so extremely thick as not to be easily penetrated, or where the springs, formed by the water passing from the higher grounds, may be confined beneath the third or fourth strata of the materials that form the declivities of hills or elevated grounds, and by this means lie too deep to be penetrated to by the cutting of a ditch, or even by boring (*Darwin's Phytologia*, p. 263.); the common mode of cutting a great number of drains to the depth of five, six, or more feet, across the wet morassy grounds, and afterwards covering them in such a manner as that the water may suffer no interruption in passing away through them, may be practised with advantage, as much of the prejudicial excess of moisture may by this means be collected and carried away, though not so completely as by fully cutting off the spring.

4229. As water is sometimes found upon thin layers of clay, which have underneath them sand, stone, or other porous or fissured strata, to a considerable depth; by perforating these thin layers of clay in different places, the water which flows along them may frequently be let down into the open porous materials that lie below them, and the surface land be thus completely drained.

4230. Where morasses and other kinds of wetnesses are formed in such low places and hollows as are considerably below the beds of the neighbouring rivers, they may, probably, in many instances, be effectually drained by arresting the water as it passes down into them from the higher grounds, by means of deep drains cut into the sides of such hills and rising grounds, and, after collecting it into them, conveying it away by pipes, or other contrivances, at such high levels above the wet lands as may be necessary: or where the water that produces the mischief can, by means of drains, cut in the wet ground itself, be so collected as to be capable of being raised by means of machinery, it may in that way be removed from the land.

4231. The drainage of lands that lie below the level of the sea can only be effected by the public, and by means of locks erected for the purpose of preventing the entrance of the tides, and by windmills and other expensive kinds of machinery constructed for the purpose of raising the stagnant water.

4232. The superficial wetness of lands, which arises from the stiff retentive nature of the materials that constitute the soils and the particular circumstances of their situations, is to be removed in most cases by means of hollow surface drains, judiciously formed, either by the spade or plough, and filled up with suitable materials where the lands are under the grass system; and by these means and the proper construction of ridges and furrows where they are in a state of arable cultivation.

4233. Having thus explained the manner in which soils are rendered too wet for the purposes of agriculture, and shown the principles on which the over-proportions of moisture may, under different circumstances, be the most effectually removed, we shall proceed to the practical methods which are to be made use of in accomplishing the business in each case.

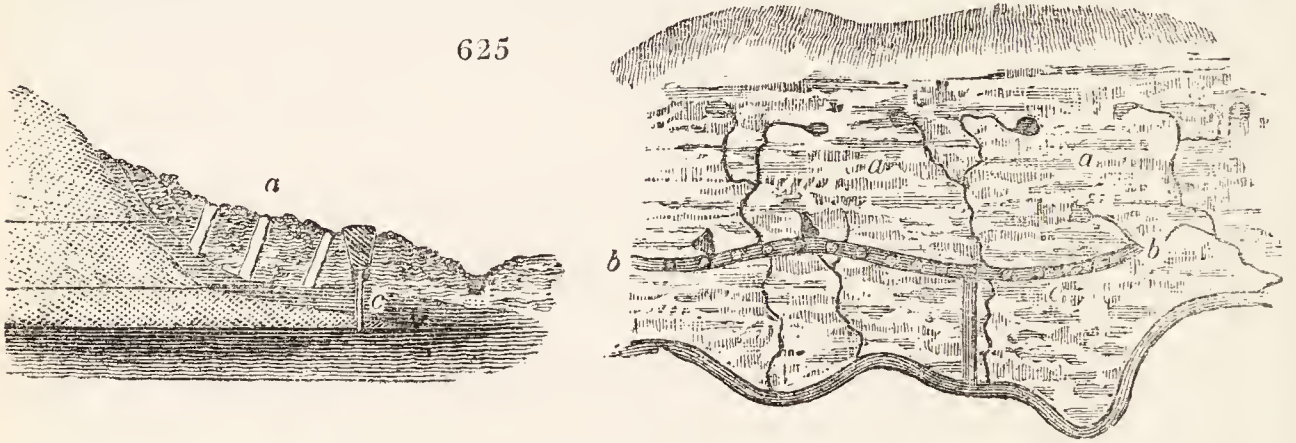
SECT. II. *The Methods of Draining Boggy Land.*

4234. In the drainage of wet or boggy grounds, arising from springs of water beneath them, a great variety of circumstances are necessary to be kept in view. Lands of this

description, or such as are of a marshy and boggy nature, from the detention of water beneath the spongy surface materials of which they are composed, and its being absorbed and forced up into them, are constantly kept in such states of wetness as are highly improper for the purpose of producing advantageous crops of any kind. They are, therefore, on this account, as well as from their occupying very extensive tracts in many districts, and being, when properly reclaimed, of considerable value, objects of great interest and importance to the attentive agricultor. Wet grounds of these kinds may be arranged under three distinct heads : first, such as may be readily known by the springs rising out of the adjacent more elevated ground, in an exact or regular line along the higher side of the wet surface ; secondly, those in which the numerous springs that show themselves are not kept to an exact or regular line of direction along the higher or more elevated parts of the land, but break forth promiscuously throughout the whole surface, and particularly towards the inferior parts (*fig. 625. a*), constituting shaking quags in every direction, that have an elastic feel under the feet, on which the lightest animals can scarcely tread without danger, and which, for the most part, show themselves by the luxuriance and verdure of the grass about them ; and, thirdly, that sort of wet land, from the oozing of springs, which is neither of such great extent, nor in the nature of the soil so *peaty* as the other two, and to which the term *bog* cannot be strictly applied, but which in respect to the modes of draining is the same. (*Johnston's Account of Elkington's Mode of Draining Land, p. 19.*)

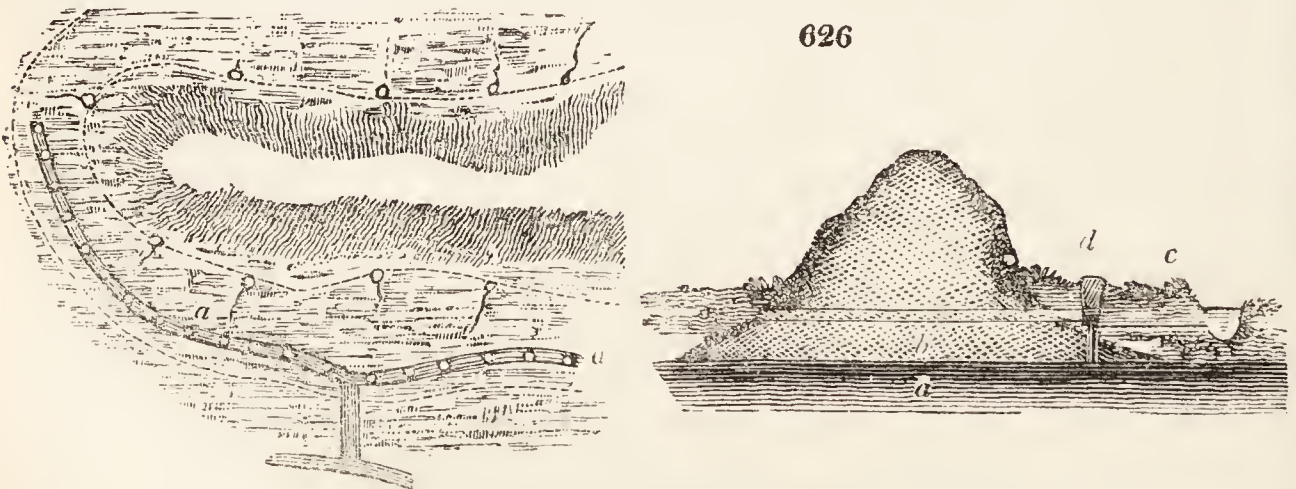
4235. In order to direct the proper mode of cutting the drains or trenches in draining lands of this sort, it will be necessary for the draining engineer to make himself perfectly acquainted with the nature and disposition of the strata composing the higher grounds, and the connection which they have with that which is to be rendered dry. This may in general be accomplished by means of levelling and carefully attending to what has been already observed respecting the formation of hills and elevated grounds, and by in-

625



specting the beds of rivers, the edges of banks that have been wrought through, and such pits and quarries as may have been dug near to the land. Rushes, alder-bushes, and other coarse aquatic plants, may also, in some instances, serve as guides in this business ; but they should not be too implicitly depended on, as they may be caused by the stagnation of rain-water upon the surface, without any spring being present. The line of springs being ascertained, and also some knowledge of the substrata being acquired, a line of drain (*fig. 625. b, b*) should be marked out above or below them, according to the nature of the strata, and excavated to such a depth as will intercept the water in the porous strata before it rises to the surface. The effect of such drains will often be greatly heightened by boring holes (*c*) in their bottom with the auger. Where the impervious stratum (*fig. 626. a*), that lies immediately beneath the porous (*b*), has a slanting direction

626



through a hill or rising bank, the surface of the low lands will, in general, be spongy, wet, and covered with rushes on every side (*c*). In this case, which is not unfrequent, a ditch or drain (*d*), properly cut on one side of the hill or rising ground, may remove

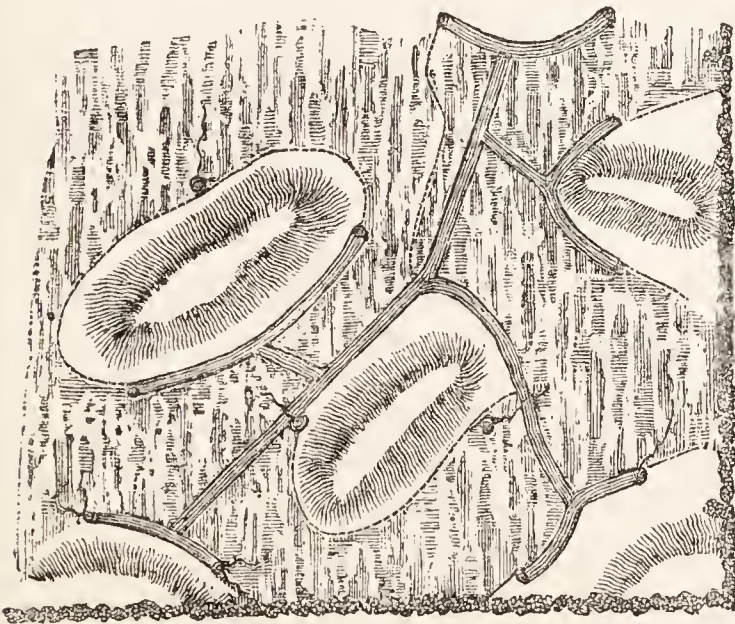
the wetness from both. But where the impervious stratum dips or declines more to one side of the hill or elevation than the other, the water will be directed to the more depressed side of that stratum; the effect of which will be, that one side of such rising ground will be wet and spongy, while the other is quite free from wetness.

4236. *Where water issues forth on the surface at more places than one*, it is necessary to determine which is the real or principal spring, and that from which the other outlets are fed; as by removing the source, the others must of course be rendered dry. When on the declivity or slanting surface of the elevated ground from which the springs break forth, they are observed to burst out at different levels according to the difference of the wetness of the season, and where those that are the lowest down continue to run, while the higher ones are dry, it is, in general, a certain indication that the whole are connected, and proceed from the same source; and consequently that the line of the drain should be made along the level of the lowermost one, which, if properly executed, must keep all the others dry. But if the drain were made along the line of the highest of the outlets, or places where the water breaks forth, without being sufficiently deep to reach the level of those below, the overflowings of the spring would merely be carried away, and the wetness proceeding from that cause be removed; while the main spring, still continuing to run, would render the land below the level of the bottom of the drain still prejudicially wet, from its discharging itself lower down over the surface of the ground. This, Johnston states, was the custom, until Elkington showed the absurdity of the practice of drainers beginning to cut their trenches wherever the highest springs showed themselves between the wet and the dry ground, which not being of a depth sufficient to arrest and take away the whole of the water, others of a similar kind were under the necessity of being formed at different distances, to the very bottom of the declivity: these being afterwards in a great measure filled with loose stones, merely conveyed away portions of surface water, without touching the spring, the great or principal cause of the wetness. The effects of drains formed in this manner he asserts to be that of rendering the surface of the land in some degree drier, so long as they continue to run with freedom; but as they are liable soon to be obstructed and filled up by sand or other materials, the water is often forced out in different places and directions, and thus renders the land as wet as before, if not wetter. In addition to this, it is a more difficult task to drain the ground a second time in a proper method, from the natural appearance of the ground being so much changed, and the bursts of the old drains, as well as the greater difficulty of ascertaining the real situation of the springs.

4237. *It may sometimes happen, however, that where the highest are the strongest outlets, they may be the main or leading springs*; those which show themselves lower down in the land being merely formed by the water of the main spring overflowing, and finding itself a passage into the earth through an opening in the surface, or through the porous materials of the soil near to the surface, and being obstructed somewhat further down in the ground by some impervious stratum. This circumstance must, therefore, it is observed, be fully ascertained before the lines for the ditches or drains are marked out.

4238. *In cases where the banks or rising grounds are formed in an irregular manner* (fig. 627.), and, from the nature of the situation, or the force of the water underneath,

627



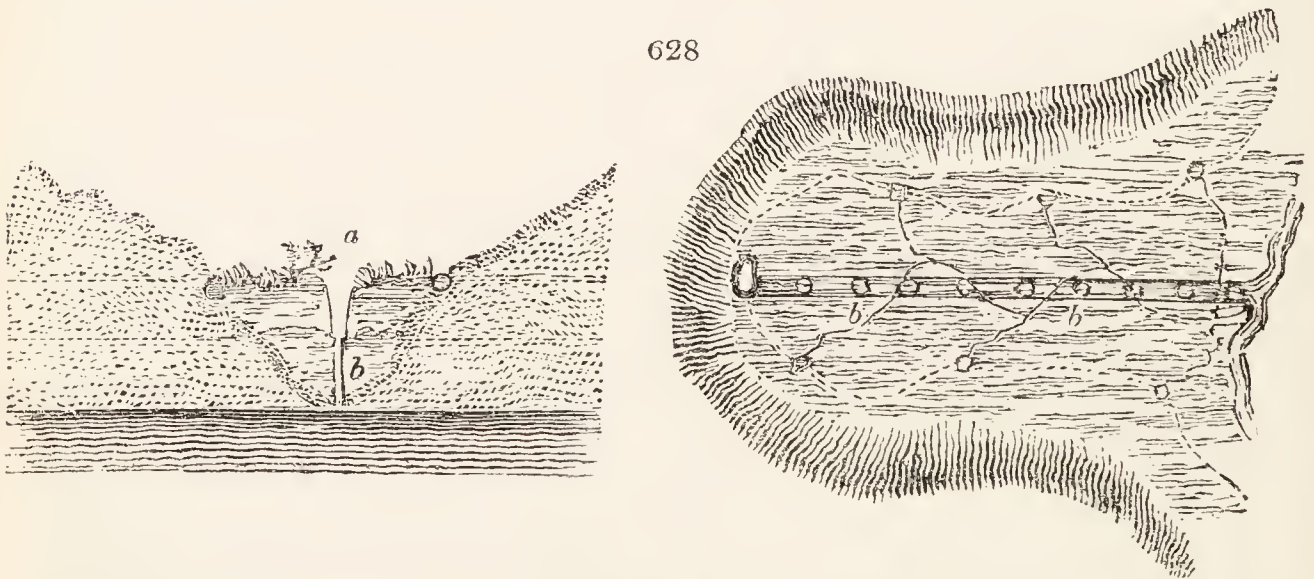
springs abound round the bases of the protuberances, the ditches made for the purpose of draining should always be carried up to a much higher level in the side of the elevated ground than that in which the water or wetness appears; as far even as to the firm unchanged land. By this means the water of the spring may be cut off, and the ground completely drained; which would not be the case if the trench or drain were formed on the line of the loose materials lower down, where the water oozes out, which is liable to mislead the operator in forming the conducting trench, or that which is to convey the water from the cross-drain on the level

of the spring to the outlet or opening by which it is discharged. But where the main or principal spring comes out of a perpendicular or very steep bank, at a great height above the level of the outlet into which it may discharge itself by means of a drain, it will neither be necessary nor of any utility to form a deep trench, or make a covered drain, all the way from such outlet up to it; as from the steepness of the descent the water

would be liable, when the drain was thus cut, from the thin strata of sand and other loose materials, always found in such cases, to insinuate itself under the bricks, stones, or other substances of which the drain was formed ; to undermine and force them up by the strength of the current, or probably, in some instances, block the drain up by the loose sand or other matters, which may be forced away and carried down by it. In situations of this kind, Johnston observes, it is always the best way to begin just so far down the bank or declivity as, by cutting in a level, the drain may be six or seven feet below the level of the spring ; or of such a depth as may be requisite to bring down the water to a level suitable to convey it away without its rising to the surface, and injuring the lands around it. The rest of the drain, whether it be made in a straight or oblique direction, need not be deep, and may, in many instances, be left quite open ; it should, however, be carefully secured from the treading of cattle, and, where the land is under an arable system of cultivation, also from the plough. Where it is covered, the depth of about two feet may be sufficient. There will not, in such drains, be any necessity for the use of the auger in any part of them.

4239. *Where there is a difficulty in ascertaining the line of the spring, and consequently that of the cross-drain, either from its not showing itself on the surface, or from there not being any apparent outlet, it may, generally, be met with in carrying up the conducting drain for conveying away the water. As soon as the operator discovers the spring, he need not proceed any further, but form the cross-drain on the level thus discovered to such a distance on each side of the tail, or terminating part, of the strata, of whatever sort, that contains the water, as the nature of the land, in regard to situation or other circumstances, may demand. Where, in forming a cross-drain, the line indicated by the spirit or other level is found to be in some places below that of the spring, and where, in boring in this direction, water is not found to follow, it will be necessary to make short drains or cuts of the same depth with the cross-drain, from it quite up to the source of the spring ; for, if the drain be cut below the line of the spring, the possibility of reaching it by means of an auger is lost, as where the under stratum is clay, and there is no under water, the use of the auger cannot be effectual ; and if it be made above the line of the spring, it will be requisite to cut and bore much deeper, in order to reach it, the ground being in general higher in that part : besides, the portion of porous stratum below the drain may contain a sufficient quantity of water to render the land wet, and that may readily get down underneath the trench, between the holes formed by boring, and break out lower down.*

4240. *In situations where the extent of bog in the valley between two banks or eminences is so narrow and limited as that the stratum of rock, sand, or other materials, that contains the water, may unite below the clay at such a depth as to be readily reached by the auger (fig. 628. a), it will seldom be necessary to have more than one trench up the middle,*



well perforated with holes (*b*) by means of the auger, cross or branching drains being unnecessary in such cases. For notwithstanding the springs, that render the land injuriously wet in these cases, burst out of the banks or eminences on every side, for the most part nearly on the same level, the reservoir from which they proceed may be discovered in the middle of the valley, by penetrating with the auger through the layer of clay that confines and forces the water to rise up and ooze out round the superior edge of it, where it forms a union with the high porous ground. From the drain being made in the hollowest part of the land, and the porous stratum containing the water being then bored into, it is obvious that, the ditch or drain thus formed being so much lower than the ordinary outlet of the springs, the pressure of water above that level, which is the bottom of the drain, must be such as to force that which is under the drain or trench through the holes made by the auger, and in many instances, until a considerable quantity of the

water is evacuated, make it rise to a greater height than the level of its natural outlet. The effect of which must be, that the water forming the spring, having found by these means a fresh and more easy passage, will quickly relinquish its former openings, and thus be prevented from running over and injuring the ground that previously lay lower down than it.

4241. *But in swamps or bogs that are extensive and very wet*, other drains or cuts than such as convey off the springs must be made; as, notwithstanding the higher springs which chiefly cause the wetness may be intercepted, there may be lower veins of sand, gravel, or other porous materials, from which the water must likewise be drawn off. In cases of this nature, where the land is to be divided into enclosures, the ditches may be formed in such directions as to pass through and carry off collections of water of this kind, as well as those that may be retained in the hollows and depressions on the surface of the land. There are in many places very extensive tracts of ground that are rendered wet, and become full of rushes and other coarse plants, from causes of such a nature as cannot be obviated by the making of either open or covered drains, however numerous they may be. Lands in this situation are frequently termed holms, and mostly lie on the sides of such rivers and brooks as, from the frequency of their changing and altering their courses between their opposite banks, leave depositions of sand, gravel, and other porous materials, by which land is formed, that readily admits the water to filtrate and pass through it to the level of the last-formed channels, and which preserves it constantly in such a state of moisture and wetness, as to render it productive of nothing but rushes and other aquatic plants; and if a pit or ditch be made in lands under these circumstances, it quickly fills with water to the same level as that in the watercourse. This effect is, however, more liable to be produced, as well as more complete, where the current of the water is slow, and its surface nearly equal with that of the land, than where its descent is rapid. Under such circumstances, while the river or brook remains at the ordinary height, no advantage can be gained, whatever number of drains be formed, or in whatever direction they may be made. The chief or only means of removing the wetness of land proceeding from this cause is, that of enlarging and sinking the bed of the stream, where it can be effected at a reasonable expense: where there is only one stream, and it is very winding or serpentine in its course, much may however be effected by cutting through the different points of land, and rendering the course more straight, and thereby less liable to obstruct the passage of the water. But in cases where there are more than one, that should always be made the channel of conveyance for draining the neighbouring land, which is the lowest in respect to situation, and the most open and straight in its course. It may likewise, in particular instances, be advantageous to stop up and divert the waters of the others into such main channels, as by such means alone they may often be rendered deeper, and more free from obstruction: the materials removed from them may serve to embank and raise up the sides to a greater height, as while the water can rise higher than the outlets of the drains, and flow backwards into them, it must render the land as wet as it was before they were formed, and the expense of cutting them to be thrown away.

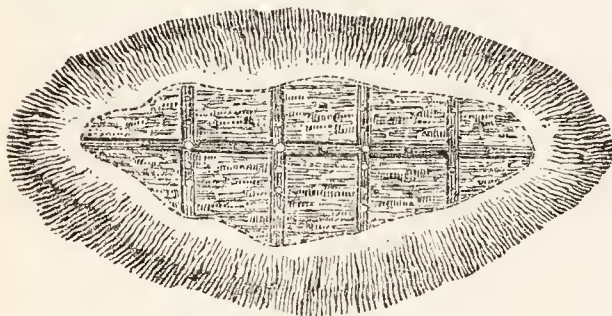
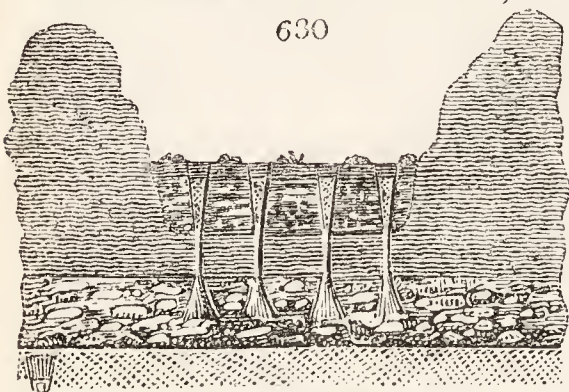
4242. *The collected rain-water, becoming stagnant* on a retentive body of clay, or some other impervious material, as it can have no outlet of the natural kind, causes such lands to become soft and spongy, thus forming bogs of a very confined kind. As such bogs are often situated very greatly below the ground that surrounds them, the opening of a main drain, or conductor, to convey off the water collected by smaller drains, would be attended, in many instances, with an expense greater than could be compensated by the land after it had been drained. The thickness of the impervious stratum that retains and keeps up the water in such cases is often so great, that though the stratum below be of a porous and open nature, such as sand, rock, or gravel, the water cannot of itself penetrate or find a passage from the one into the other; consequently, by its continued stagnation above, all the different coarse vegetable productions that have for a great length of time been produced on its surface, and probably the upper part of the soil itself, are formed into a mass or body of peat earth, equal in softness to that of any bog originating from water confined below, and less productive, and which is only capable of sustaining the weight of cattle in very dry seasons, when the wind and sun have exhaled and dried up a great part of its surface moisture; but even then it is incapable of admitting the plough upon it.

4243. *As these kinds of bogs differ materially in their origin* from those which have been already noticed, their drainage must of course be accomplished in a different way. The following method of proceeding is recommended as perhaps the least expensive:—In the middle, or most depending part of the ground, the first drain (*fig. 629. a*), may be cut, into which all the others should be made to lead; the number and direction of which must be regulated by the extent of the bog. They should be cut through the peat, or moist spongy upper soil, to the surface of the clay, or other retentive stratum of materials, which must then be perforated or bored through in order to let the water down into the pervious stratum below, by which it may be absorbed and taken up. The same effect might be produced by digging one large well, or pit, in the middle or lowest part of the bog, through into the porous stratum below, and connecting the other drains with it, as by such a method the trouble and expense of boring along the drains would

be saved. In these cases, when drains are made, they should always be cut as narrow as it is possible to make them, and, after the holes have been formed in them by boring, filled up with loose stones to within about a foot and a half of the surface, which space may be made up by a portion of the earth that had been taken out, putting in turf with the green side to the stones before the earth is thrown in. By this means the water and prejudicial moisture of the peat, or upper soil, may be taken away by the drains, and pass off through the holes that have been formed in their bottoms. But where pits are employed, these should only be filled with small stones to the level of the bottom of the drain, the filling being performed as soon as possible after they are formed. (*Anderson's Treatise on Draining*, p. 88.) Where there is a chalky stratum below, after taking it out, the flints contained in it may be made use of in this way with much advantage; and where the drains can be carried into quarries, where the stone is much fissured nothing more will be necessary. Where land of this sort is afterwards to be ploughed, great attention should be given to the forming of the ridges and giving them a regular descent towards the main

drain, which will contribute greatly to the assistance of the others in conveying off heavy falls of rain-water when they occur.

4244. *But a necessary precaution* previously to any attempt to drain lands of this kind in the way that has been described, is to ascertain whether the porous stratum under the clay be dry, and capable of receiving the water when let down into it; or already so loaded with moisture itself, as, instead of receiving



more from above, to force up a large quantity to the surface, and thus increase the evil it was intended to remove. This may be the case in many instances, and the substratum contain water which affords no appearances of wetness on the surface, at the place, on account of the compact body of clay that is placed over it, but which, from its being connected with some spring that is higher, may flow up when an opening or passage is given it, either by means of a pit or the auger. In this way a greater quantity of water might be brought to the surface, which, from its being confined by the surrounding banks, would render the ground much more wet than before, and in particular situations produce very great degrees of wetness. When the surrounding high ground declines lower than the bog, though it may be at a considerable distance, by the aid of the level, and the appearance of the surface, the nature of the stratum underneath may, in some degree, be ascertained; and, notwithstanding it may already contain water, a drain may be formed into it to carry off that water, and what may likewise be let down into it from the retentive stratum that lies above it. It must be confessed, however, that cases where surface water can be let down through a retentive stratum to a porous one that will actually carry it off, are very rare. When these occur, it is chiefly in limestone or coal districts, where the surface is hilly or rugged (*fig. 630.*), and more calculated for

the pursuits of the mineralogist than those of the agricultor.

SECT. III. *Draining Hilly Lands.*

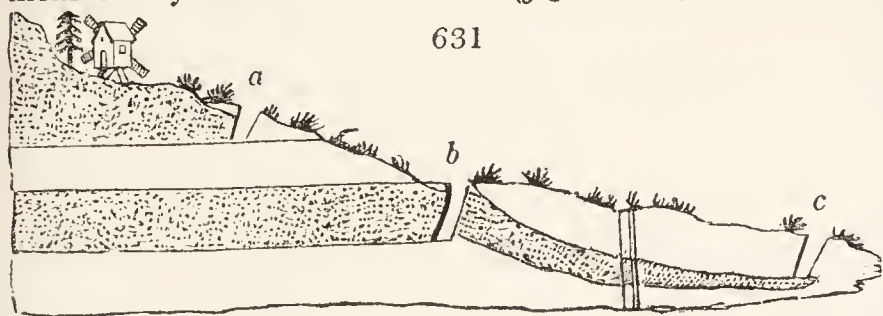
4245. *Draining hilly lands* is not in general attended with great expense, as the drains need seldom be covered or filled up, only in such places as may be sufficient for passages for the animals to cross by: and though, where the depth of the trench does not come to the water confined below, it may be necessary to perforate lower, there need not be any fear that the holes will fill up, even where the drain is left open; as the impetuosity of the water itself will remove any sand or mud that may fall into them, where much flood or surface water does not get in. Small openings may, however, be made along the upper side of the trench, in order the more effectually to secure them against any obstructions; and in these the perforations may be made, leaving the mouth of the holes about six inches higher than the bottom of the drain, which will be without the reach of the water that may be collected during the time of heavy rains.

4246. *One of the greatest improvements of the hilly sheep-pastures* of Holland has been effected by drainage, while the expense is comparatively small. The depth and width of the small ones are only those of the spade. They are usually carried across the face of the hills in a slightly inclined direction, so as to avoid the injury of too rapid a descent after heavy rains; and these small cuts open into a few larger, formed with due regard to the same principle; the whole at last, for an extent of several hundred acres, being led into one still larger, which discharges itself into the nearest rivulet. Improvements of this kind are, perhaps, of greater benefit to the individual proprietors of land who undertake them than any other.

4247. *The sides or declivities of many hills*, from the irregularity of the disposition of the strata that compose them, are often covered with alternate portions or patches of wet and dry ground. By the general appearance of the surface and the vegetable products that are grown upon it, the nature and direction of the internal strata may frequently be ascertained with so much certainty as to determine the line or direction of a drain without the necessity of examining below the surface of the land. As the ease or difficulty

of draining such grounds depends solely on the position of the different strata of which the hill or elevation may be formed, and upon the erect or slanting direction of the rock, or other retentive body in which the water is contained; where the rock has a slanting or horizontal inclination, the whole of the different springs or outlets, that show themselves on the surface, may originate from or be connected with the same collection or body of water, and may be all drained and dried up by cutting off, or letting out, the main body of water, by which they are supplied, at the inferior part of the reservoir, or that part where the water would of its own accord readily run off if it were not confined beneath an impervious covering of clay or some other material.

4248. *But in cases where the rock lies in an erect or perpendicular form, and contains only partial collections of water, in some of the more open cracks or fissures of the stone, which discharge themselves at various openings or outlets that have not the least connection with each other, it would be an idle and fruitless endeavour to attempt the cutting of them off by means of one drain (fig. 631. a), or by boring into any one of them in*



particular, without cutting a drain into each (a, b, c). In this case it is more advisable to make the main drain wholly in the clay, with small cuts made up to each outlet, than along the place where the springs burst out; as in that line of direction it would be

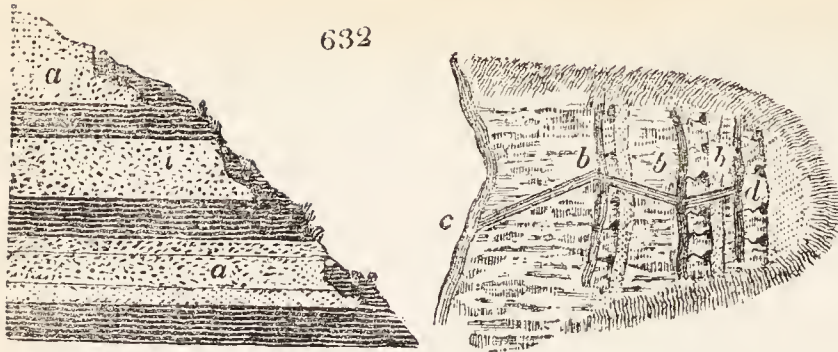
too much in the rock, and consequently be extremely difficult to cut, on account of the nature and disposition of the stone. When the water passing out on the line of the springs can be found by the auger in the main drain, at the point of junction, it will be the more completely cut off; but where this is not practicable, the depth of the small cuts may reduce it to such a level as will prevent its flowing over and injuring the surface of the land below it.

4249. *In such hills as are constituted of alternate strata of rock, sand, and clay, the surface of the last may frequently be wet and swamp, while that of the sand is dry, and capable of producing good crops of grass; in all such cases, in order to drain the land completely, as many cuts will be necessary as there may happen to be divisions of wet and dry soil. The summit, or most elevated part of such hills, being mostly formed of loose porous materials, the rain and other water descends through it till its passage becomes obstructed by some impervious bed or stratum, such as clay, when it is forced up to the surface, and runs or oozes over the obstructing stratum; after having overflowed the upper clay surface, it is immediately absorbed and taken up by the succeeding porous one, and, sinking into it in the same way as before, passes out again at the lower side, rendering the surface of the next clayey bed prejudicially wet, as it had done that of the first. In this way the same spring may affect all the other strata of the same kind, from the highest part down the whole of the declivity, and produce in the bason, or hollow at the bottom, a lake or bog, should there not happen to be a passage or opening to take away the water. In order effectually to drain hills of this kind, it will be most advisable to begin by forming a trench along the upper side of the uppermost rushy soil, by which means the highest spring may be cut off; but as the rain and other water that may come upon the next portion of porous soil may sink down through it to the lowest part, and produce another spring, a second cut must be made in that part, to prevent the water from affecting the surface of the succeeding clayey bed. Similar cuts must be formed so far down the declivity as the same springs continue in the same way to injure the land, and in some cases a sufficiency of water may probably be obtained to irrigate the land below, or for some other useful purpose.*

SECT. IV. *Methods of draining Mixed Soils.*

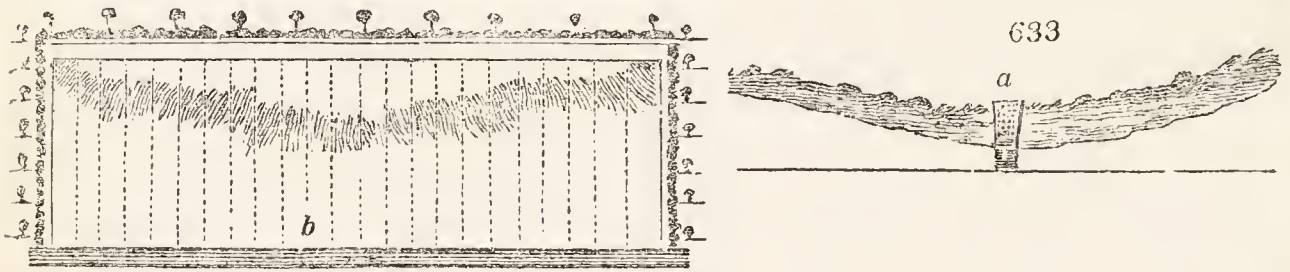
4250. *Where the soil is of a mixed and varied nature, but the most prevailing parts of the clayey kind, the business of draining is considerably more tedious and difficult than where the superficial and internal parts have greater regularity. In such lands, as the collections of water are completely separated by the intervening beds of clay, each becomes so much increased in the time of heavy rains, as to rise to the level of the surrounding surface; when the water, finding a free passage, as it would over the edges of a bowl, overflows and saturates the surface of that bed of clay, rendering it so wet and sour that its produce becomes annually more scanty, and the soil itself more sterile and unproductive.*

4251. *From the sand-beds (fig. 632. a, a, a) in such cases having no communication with each other, it must evidently require as many drains (b, b, b) as there are beds of this kind, in order fully to draw off the water from each of them. A drain or trench is therefore recommended to be cut from the nearest and lowest part of the field intended*



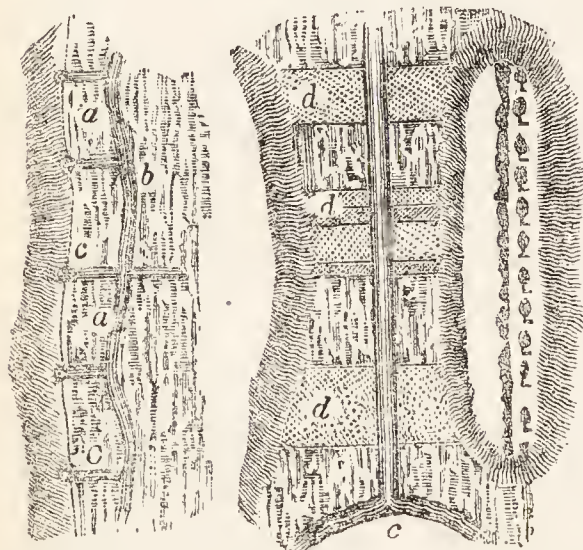
to be drained (c), up to the highest and most distant sand-bank (d), in such a line of direction as, if possible, to pass through some of the intermediate sand-beds, and prevent the labour and expense of making longer cuts on the sides, which would otherwise be requisite.

4252. Where the different beds of sand and clay are of less extent, and lie together with greater regularity, they can be drained in a more easy manner with less cutting, and of course at less expense. Below the layers or beds of sand and clay that lie, in this manner, alternately together, and nearly parallel to each other, is generally a body of impervious clay, which keeps up the water contained in the sand, which sand being constantly full, the adjacent clay is thereby rendered moist, and in wet seasons the water runs or trickles over it. As in these cases, the principal under-stratum of clay is rarely more than four or five feet below the surface, it is advisable to cut a drain (fig. 633. a)



to that depth through the middle of the field, if it have a descent from both sides; but if it decline all to one side, the drain must be made on that side (b), as the water will more readily discharge itself into it; and, unless the field be of great extent, and have more than one depression or hollow in it, one drain may be quite sufficient for the purpose, as by crossing the different beds that retain the water, it must take it off from each.

4253. A principal difficulty in draining ground of this nature, and which renders it impracticable by one drain, is when the direction of the alternate layers, or beds of clay and sand, lies across the declivity of the land (fig. 634. a, a), so that one drain can be of no other service than that of conveying away the water after it has passed over the different strata, and would naturally stagnate in the lowest part of the field, if there were no other passage for it.



Where the land lies in this way, which is frequently the case, it will therefore be necessary, besides the drain in the lowest part (b), to have others cut up from it in a slanting direction across the declivity (c, c), which, by crossing the different veins, or narrow strata of sand (d, d, d), may be capable of drawing the water from each of them.

4254. In forming the drains in these cases, it is recommended that, after laying the bottom in the manner of a sough, or in the way of a triangle, it be filled some way up with small stones, tough sods with the green side downwards being placed upon them before the mould is filled in. But where stones cannot be readily procured, faggots may be employed, the under part of the drain being laid, or coupled, with stones, so as to form a channel for the conveyance of the water that may sink through the faggots, and for the purpose of rendering them more durable; as, where the water cannot get freely off, which is generally the case where there is not an open passage made of some solid material, it must, by its stagnation, soon destroy the faggots, and choke up the drain.

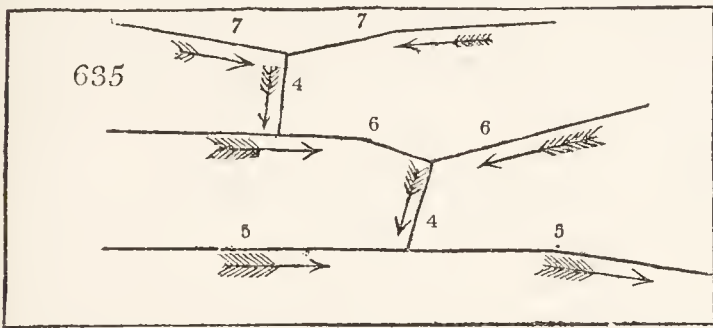
4255. The estate of Spottiswoode in Berwickshire affords an interesting example of successful drainage of mixed soil and strata. It was begun in 1815, under the direction of Mr. Stephens, an eminent draining engineer, and author of a useful work on the subject (*The Practical Irrigator, &c.*, Edin. 8vo. 1829); and eighteen miles and a half of drains, some parts of which were thirteen feet deep, but the medium depth of which was from five to seven feet, had, in 1820, rendered between five and six hundred acres of land most valuable, which had been before of little value.

4256. The grounds to be drained at Spottiswoode "consisted of a soil of various depth, under which commonly lay a stratum of clay from two to three feet deep, then a thin bed of sandy or gravelly substance, of a foot deep, or more, containing water; after that another bed of clay, of two or more feet deep; and lastly, a bed of sand, gravel, or slaty rock, containing the larger quantity of water. Upon reaching the

lower of these porous strata, the water disappeared in the upper one : and hence generally the expediency of not stopping at the first, but of working down till the main stratum was reached. Several instances occurred where the strata lay too deep to be reached by a drain ; in which cases it was deemed necessary to sink wells or pits at certain distances along the line of the drain, from ten to eighteen feet deep, or more, in order to reach the open strata, so that the water, rising through the wells to the bottom of the drains, might be conveyed away without reaching the surface. It was never thought sufficient to have reached the first seam containing water, unless it were at the depth of four feet or more, and evidently appeared to be that containing the main body of water which occasioned the wetness of the surface." (*Trans. Highl. Soc.*)

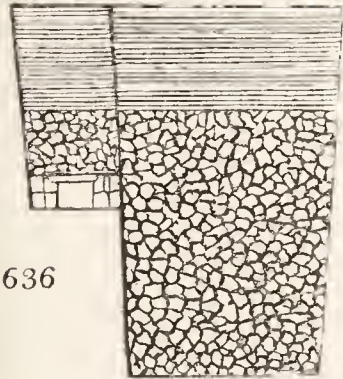
4257. *The first operation in the process of draining* " was to ascertain the depth and nature of the strata in which the water was contained, and the overflowing of which, where no outlet existed, produced, as was before remarked, either springs or bursts of water, or a general oozing. Along the line of these springs, or in the upper part of the wet ground, pits were sunk in various places. The place of each being marked out, a man was sent to dig each pit, breaking the ground nearly in the direction of the intended drain, six feet long and three feet wide, which is sufficient space to allow a man, or sometimes two, to work freely. The earth was then thrown to the lowest side, and well off from the pit, to prevent the sides from breaking in : these pits were made to the depth of five or six feet, or to a greater depth if necessary, according to the nature of the ground, or until the bed of sand, gravel, or rock, which contained the water, was reached. Sometimes it became necessary, after having gone as deep as a man could work, and when no water appeared, to bore down with boring-rods, in order to ascertain at what depth the stratum containing the water lay. In some instances, where the surface was wet from a general oozing, and no regular spring appeared, it became necessary to go down to the depth of thirteen feet, when, in breaking through a thin cake of freestone, not above an inch in thickness, the water burst up, and filled the pit to the brim in the following morning. This species of examination prevents the working at random in laying out the lines of drains, affords data for judging of the depth and dimensions to which they should be formed ; and, by giving a knowledge of the substances to be dug through, enables one to enter into contracts with the workmen with greater certainty." (*Trans. Highl. Soc.*)

4258. *A general idea being thus obtained of the ground to be drained*, and men employed to sink the pits, the next operation is to mark out these lines on the ground. In doing this, a hand sketch (*fig. 635.*) indicating the direction of the drains and their depth will be found useful. " On the ground, the lines may be marked in various ways. When the land is in grass, a plough may be made to follow the director, as he walks deliberately along his intended line, a man leading the horses by the head, if necessary, and walking between them. If it is inconvenient to use a plough, the lines may be marked by pins, or small pits, a spade's breadth square, made at convenient distances, by cutting out a turf clean by four cuts of a spade, and laying it upside down at the side of the



hole, in the line of the drain." The drains were next dug out, and formed; some of them three feet wide at the top, six feet deep, and two feet wide at bottom, and others of different widths and depths, but generally in the same proportion. The following are Mr. Stephens's directions for building :—

4259. *The side walls of the drain*, supposing it to be six feet deep, and two feet wide at bottom, " must be well built with dry stone, all laid on the proper bed (and not set up edgeways), nine inches thick by six inches high, forming an aperture of six inches square, the covers for which must be sufficiently strong to sustain the pressure of the incumbent weight of stone and earth ; and should project, at least, three inches over the inside of each side wall, — two feet of stone must be well packed above the cover of the aperture. The first foot of stone above the cover of the aperture may be put into the drains from three to four pounds weight, the upper part must be broken as small as common road-metal, and should be made quite smooth or level, so that every part of the drains may have an equal depth or thickness of stone. A thin covering of straw should be laid on the top of the broken stones, to prevent the loose earth from falling through the aperture of the drains. The drains may be then filled with earth, nine inches above the natural level of the surface of the ground. Wells must be sunk along the lowest side of the lines of drains, in every place where the above mentioned depth of six feet does not reach the porous bed that contains water. These wells may be made from five to six feet square, or sufficiently wide to allow a person to work with freedom ; and must be sunk through the impervious strata into the pervious stratum of sand, gravel, or rock, where the water flows freely. The wells may then be filled with small clean stones, thrown in promiscuously, till the stones in the wells come in contact with the stones in the drains. The upper part of the wells above the level of the stones in the drains may be filled with earth." (*fig. 636.*) (*Trans. Highl. Soc. vol. vii. p. 222.*)



4260. *The stones of which the drains at the bottom of the conduit are to be built*, and with which the drain is afterwards to be filled to the depth of two feet or more, as is shown above, should be laid down on the upper side of the line, as near to it as possible, that they may be the more easily handed in. They are laid on the upper side, for the convenience of throwing out the earth on the lower side. It is very desirable that the stones should be, if possible, laid down before the drain is begun to be dug, as it is often necessary to build and fill it as fast as it is dug, to prevent the sides from falling in, which, when it occurs, occasions a very great deal of extra work, and the drains themselves are never so well constructed. This most frequently happens in ground under tillage, the sides being more tender than when in grass, where the turf is the means of preserving the sides from the pressure of the earth thrown out, and of the stones laid down. When the sides are evidently likely to fall in before the drain can be built, they may be kept up for a time by a board laid flat to each side of the drain near the top, and cross sticks put in to keep the boards asunder. Circumstances frequently occur, which prevent the stones from being laid down beforehand, and they are then brought forward as the work of cutting the drain is going on. Under the eye of an intelligent and attentive director, this may be done without danger ; but, even then, unforeseen occurrences sometimes prevent the possibility of getting the materials forward for several days ; and if any rainy weather intervene, and the drains are in a clayey soil, there is a certainty of slips and falls, occasioning much extra labour, and requiring, in consequence of the additional breadth of the drain, a much larger quantity of stones to fill the opening. Where a piece of drain seems likely to fall in, it should always, if possible, be built and filled before night, or the sides kept asunder by means of boards, as before mentioned." (*Trans. Highl. Soc. vol. vii.*)

4261. *Drains may be dug*, and, when built, the earth may be filled in by contract work ; but in general day work is to be preferred. " The conduit is built in the bottom of the drain by a confidential person, either a mason, or any other workman

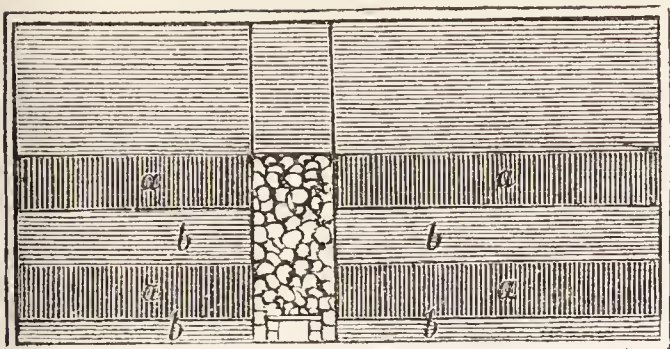
who, by practice, is equally competent; this person always working at daily wages, to prevent him from having any interest in hurrying over this most important part of the operation."

4262. *The drains may be cut* only "two feet wide, with the sides perfectly perpendicular, provided that, from the tenacity or hardness of the substances dug through, the sides will stand till the stones are put in. It is usual, however, to break the ground somewhat wider at the top, and so to give it a slight slope to the bottom. The work of cutting is always done by contract at so much per rood or yard, and several labourers generally join in making one drain, and arrange the work among themselves. The casting or cutting, it is scarcely necessary to observe, is always commenced by the workmen at the lower end, and worked upwards to the higher ground, and never downwards. They usually begin by working about two feet deep in the first instance, several roods in length, then going over the ground again, deepening it to four or five feet, and afterwards going over it the last time, and finishing the bottom, by making it perfectly level and ready for the mason to build the conduit in the bottom. The bottom must, for this purpose, be completely two feet wide, though, when free-stone is employed, the width may be less." (*Trans. Highl. Soc.*)

4263. *In building the drain*, "the mason has an assistant, generally a female, at the top, who hands him the stones he requires. He begins with small flat stones to build the wall on each side of the bottom of the drain, nine inches broad, and six inches high, so as to leave six inches for the conduit in the middle. This he does roughly, but in such a manner that the stones shall be laid solidly on one another. When the ground at the bottom is solid, either dry gravel, or clay, or rock, the mason's foot, with his ordinary clog or shoe, standing in the centre, is the measure of the width of the conduit. When the land is inclined to be wet and soft, a plank six inches broad is used for him to stand upon. When the bottom is a wet spongy clay, or sand of the nature of a quicksand, or very soft, it is often necessary to flag the bottom of the conduit with very thin stones or slates." (*Trans. Highl. Soc. vol. vii.*)

4264. *When a perfect quagmire has been met with*, "which has happened chiefly in red clay, the faster the wet clay has been thrown out, the faster it has boiled up from below. In these cases, it has been found necessary to lay planks on the bottom of the drain, and build upon them. But this will very seldom be necessary where proper precautions are used. On first meeting with quagmires of this kind, attempts were made to dig them out; for which purpose a strong wooden frame was made, large enough for four men to work in with freedom, composed of different pieces, so that the workmen might add to the sides of the frame as they worked downwards. Notwithstanding the frame's being made very strong, the pressure became so great, that the sides came together, and stopped the operation. The consequence was, that, after great labour and active exertion in taking out large quantities of wet clay, which thus continued to boil up (but the very taking out of which undermined the banks from beneath), the sides of the drain fell in masses, and made great gaps, which increased the longer the work was carried on. In these circumstances, it became necessary to use planks to build the conduit, and to fill in the stones as fast as possible, by employing a great number of persons at once. The weight of these superincumbent stones then kept the planks and conduit at their proper place, so much so that the worst of these parts never exhibited any symptom of imperfection, though made ten years ago. On all occasions afterwards, however, when any of these quagmires were found, the process of taking out the bottom of the drain was followed, yard by yard, by flagging the bottom, building the conduit, covering it, and filling the stones over it; and in this way the quagmire was prevented, by the immediate pressure from above, from boiling up. It never failed to be seen that the longer these operations were delayed, the softer and more intractable the interior of the drain became. After building the side walls for a yard or two in length, the mason, according to circumstances, cleans out the conduit with a narrow hoe, and then covers it with such large broad stones as he can procure, from fifteen inches in length to two feet, being the utmost width of the drain itself. These are handed down carefully to him by his attendant; and, after he has laid three or four of them, he takes smaller flat stones, as the larger are always uneven at the edges, and covers every interstice; and afterwards, with similar stones, packs carefully the ends of the covers, before finishing any particular portion of the work so as to prevent them from shifting; and still further to cover every hole through which any thing might be carried into the conduit, he has a rolled up wisp of straw which he puts in the mouth of the conduit, which allows the water to pass out, but prevents mud and sand from getting in. His attendant then throws the remainder of the stones in promiscuously to the depth of two feet, or sometimes more, if the materials are plentiful, and particularly where there are two seams con-

637



taining water; for in this case it is generally desirable to raise the stones above the level of the bottom of the upper seam, so as to convey away any water which may remain in it, to the conduit beneath (*fig. 637. a*, sand or gravel; *b*, clay); and it was a circumstance very generally observed in the course of operations, that where the upper stratum containing water was only a few feet in depth or thickness, another open stratum was generally found a few feet deeper.

4265. *Stones.* When the stones to be used are only brought forward at the time of cutting the drain, the carts are often run back to the edge of it, and the stones, after the conduit is built, tumbled straight out of the cart into the drain; but, in this case, it is necessary to take care that the sides of the drain be not injured by the cart-wheels or otherwise, lest the earth should fall into the drains, and so through the intervals of the stones. A part of the stones for filling were recommended by Mr. Stephens to be broken like large road metal. This, however, is very expensive, and was found by experience not to be necessary, though usually large stones should be broken. When the stones are small, that is, ten or twelve ounces, it is as well; but no inconvenience has been found from the constant use of stones of a much larger and very unequal size. When a sufficient quantity of stones has been thrown in, the mason levels them at the top, filling up the intervals of larger stones with smaller ones, so as to make the top of them level. If the sod which has been cut off the surface of the drain is sufficiently solid, it should be laid carefully by itself on the upper edge of the drain at the side of the stones. It should again be laid with its grassy side undermost, on the top of the stones, as a covering, to prevent the earth from getting down amongst them. If the sods are not sufficiently coherent or plentiful to cover the whole completely, old coarse hay, or straw, or heath, may be used as a substitute. When all this is completely done, the earth is shovelled in upon the top, until the drain is full. It is then heaped up, somewhat after the manner of a grave, to allow for the earth's subsiding to the level of the surface. It is a circumstance deserving of notice, that, in digging the trial-pits, the earth taken out is in most cases insufficient to fill them again, if allowed to lie open for any time; so that, in fact, contrary to what would be naturally inferred, the earth must become more compact by being removed.

4266. *Repairs.* When the drain is thus completed, it is still necessary, and particularly when the land is under tillage, carefully to inspect it from time to time, and to see that no surface-water finds its way into it. If any hole is found, it ought to be immediately stopped up, as a channel of this kind will sometimes very speedily carry enough of mud into a conduit to choke it entirely, and spoil the drain. Under-draining, it will be kept in mind, will not supersede the necessity of surface-drains, where these are necessary to carry off water stagnant upon the ground. Besides the danger to drains by the flowing in of surface-water, there are other sources of injury which must be guarded against by a vigilant care. Animals, by burrowing in the earth, or finding their way from any course in the conduit, are sometimes apt to injure it, and cause the earth to crumble in; but a more frequent source of injury is from vegetable substances, as roots of trees, and particularly of the ash. As an instance of this, there happened, on this property, to be an ash tree growing near a drain, the fibres of which took possession of the conduit, and so obstructed the passage of the water, as to produce a new swamp, in consequence of which it became necessary to lift the materials of the drain, and form it anew. It is often very difficult to eradicate certain plants, whose long and creeping roots get intervened in the interstices of the conduit. The advance of those larger animals which enter the conduits for safety, or in pursuit of prey, may be prevented by an iron grating at the outlet. (*Trans. Highl. Soc. vol. vii.*)

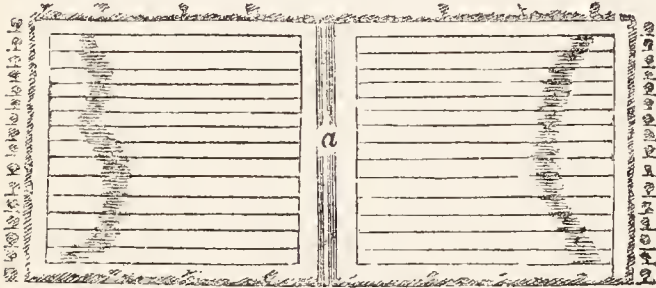
SECT. V. *Methods of draining Retentive Soils.*

4267. *The mode of draining retentive soils* is materially different from that which has been described above. Many tracts of level land are injured by the stagnation of a superabundant quantity of water in the upper parts of the surface materials, which does not rise up into them from any reservoirs or springs below. The removal of the wetness in these cases may, for the most part, be effected without any very heavy expense. From the upper or surface soil, in such cases, being constituted of a loose porous stratum of materials, to the depth of from two to four or five feet, and having a stiff retentive body of clay underneath it, any water that may come upon the surface, from heavy rains, or other causes, readily filtrates and sinks down through it, until it reaches the obstruct-

ing body of clay; the consequence of which is, that the porous open soil above is so filled and saturated with water, as to be of little utility for producing crops of either grain or grass. Land thus situated is frequently said by farmers to be wet-bottomed. In order to remove this kind of wetness, it seldom requires more than a few drains, made according to the situation and extent of the field, of such a depth as to pass a few inches into the clay, between which and the under surface of the porous earth above there will obviously be the greatest stagnation, and consequently the largest collection of water, especially where it does not become much visible on the surface. In these cases there is no necessity for having recourse to the boring instrument, as there is no water to be discharged from below.

4268. When the field to be drained has only a slight declination, or slope, from the sides towards the middle, one drain cut through the porous superficial materials into the clay, in the lowest part of the ground (fig. 638. a), may be sufficient to bring off the whole of the water detained in the porous soil. This effect may likewise be greatly promoted, by laying out and forming the ridges so as to accord with the direction of the land, and by the use of the plough or spade in removing obstructions, and deepening the furrows. In such

638

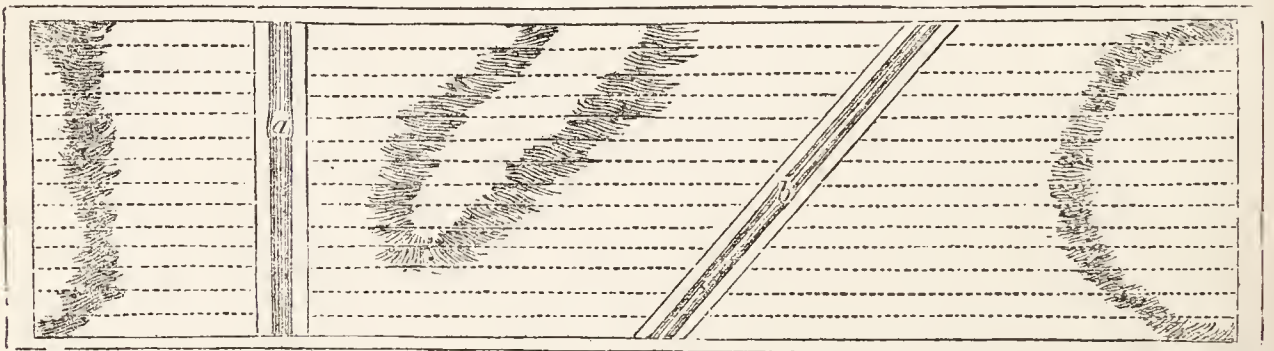


situations, where the drain has been formed in this manner, the water will flow into it through the porous surface materials, as well as if a number of small trenches were cut from it to each side, as is the practice in Essex and some other parts of the country; but which is often an unnecessary labour and expense. The drain made in the hollow may frequently serve as a division of the field (a), in which case it may be open;

but in other circumstances it may be more proper to have it covered.

4269. Where a field of this description has more than one hollow in its surface (fig. 639. a, b), it will obviously be requisite to have more than one main drain; but when it is nearly level, or only inclines slightly to one side, a trench or drain along the lowest part, and

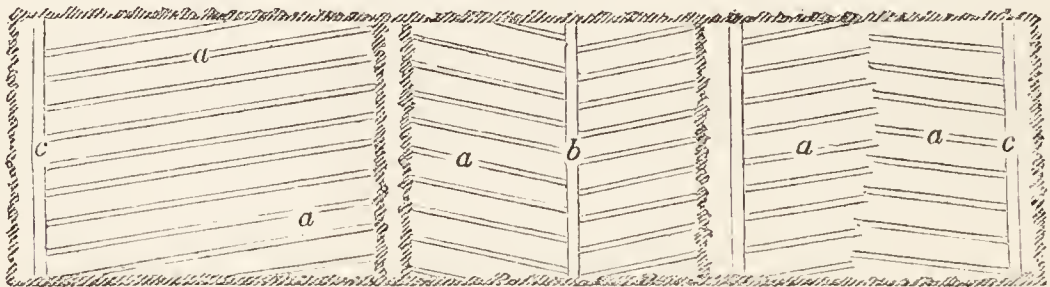
639



the ridges and furrows formed accordingly, may be sufficient for effecting its drainage. There may, however, be cases, as where a field is large and very flat, in which some side-cuts from the principal drain may be necessary, which must be made a little into the clay, and as narrow as they can be wrought, and then filled up with stones or other suitable materials.

4270. What is called the Essex method of draining in ploughed springy lands, where the surface soil is tenacious, is described by Kent, and consists in substituting small under-drains (fig. 640. a) for open furrows; or in some cases having a small under-drain beneath

640



(b) every other or every third furrow. These drains lead to side or fence ditches (c), where they discharge themselves.

4271. Where the clay constitutes the surface, and the porous body is underneath, the injurious stagnant water cannot possibly get off, without the assistance of drains formed for the purpose. Soils of this nature are drained with difficulty, and require a much greater number of trenches or cuts than those of any other kind, as they must be marked out and disposed in such a way as to collect and convey the water every where from the surface; because it can only force itself off into them from above, being prevented from

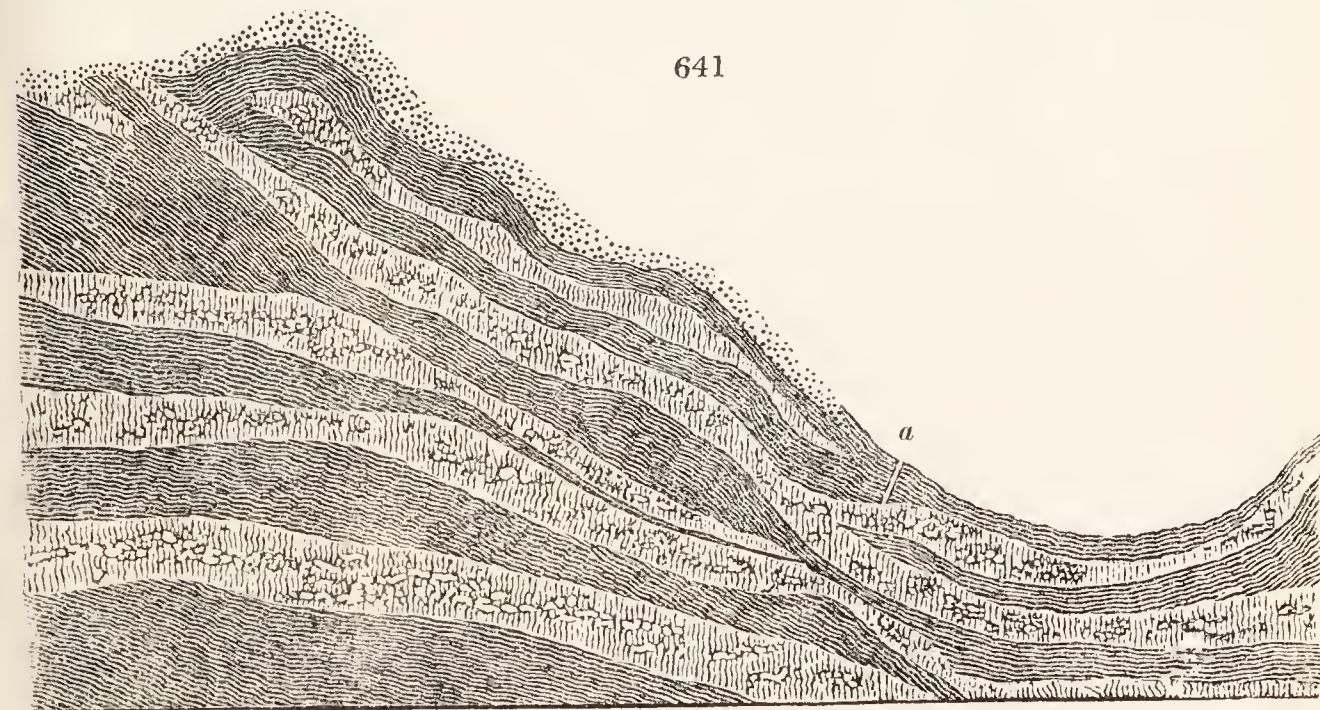
sinking in through the clay, as in soils of a contrary kind. Where there happen to be hollows or irregularities in the surface of the land, water may often be observed to continue standing in them, at a distance of but a few feet from the drain. In draining such lands, it will always be necessary, in the first place, to make a large or conducting drain at the lowest part, or the end of the field, for the purpose of receiving and conveying away the water collected by the smaller collateral cuts which it may be necessary to make on each side of it. Where it suits for the purpose of dividing the land, this principal drain may be better open than covered, as by that means the mouths or outlets of the different small drains that come into it may be conveniently examined, and cleared out when necessary.

4272. *The construction of the ridges in such soils, so that they may accord with the declivity, is a matter which must be carefully kept in view.* They should in all such cases have a degree of elevation or roundness in the middle, sufficient to afford the water a ready fall into the furrows, which likewise should have such a depth and fall as may take it quickly into the drains. The ridges, besides being well laid up, should have small open drains formed in a slanting direction across them, in such a manner as to form communications with one another, and with the furrows; by which means they are made to perform the office of drains; the water coming upon the ridges being thus readily conveyed into the furrows, along which it proceeds till impeded in its course by the rising of the ground or other cause; it then passes through the open cross-drains into others where the descent is greater, and is ultimately conveyed off into the ditch, or other passage, at the bottom of the enclosure. The elevation of the ridges should probably, too, be made greater for the winter than the summer crops, as there must be much more injurious moisture at the former than the latter season. This may be easily accomplished at the time of ploughing the land. Some useful observations on this description of drainage will be found in Marshal's work on *Landed Property*, and in Dr. Anderson's *Treatise on Draining*.

SECT. VI. *Methods of draining Mines, Quarries, Pits, Ponds, and Lakes.*

4273. *Where pits, mines, or quarries, happen to be formed at the bottom of declivities, and are inconvenienced or wholly obstructed, either in the digging or working, by the water contained in them, it may be possible, in many cases, to prevent its coming into such mines or pits, by cutting or boring into the lower parts of the porous strata (fig. 641. a).* In order to accomplish this object, it will be necessary to ascertain if any

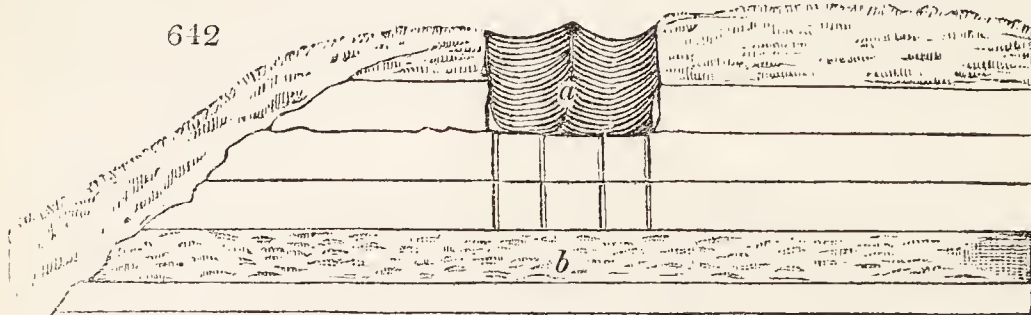
641



porous stratum presents itself higher up the elevation than the place where the mine or pit is formed, that may conduct the water it contains to the porous body below it; as by cutting into such stratum, where discovered, much of the water may be drawn off and prevented from passing down. But notwithstanding the water from above may be cut off in this way, a quantity sufficient to inconvenience the working of the mine or pit may still filtrate from the sides of the porous bed, even though it may incline in the direction of the lower ground. When this is the case, it may, however, be readily taken away at some place in the bed. To accomplish this, and thereby obviate the effects of the water, the termination of the porous stratum (fig. 641. a) below the pit must be ascertained; and where there is any mark of a natural outlet at the place, a large drain should be formed, in order to permit the water to flow off with more expedition. Where, however, there is a thick bed of some impervious substance, such as clay, placed upon

the termination of the porous material, the drain need only be cut a little way into that, as by boring through the rest a sufficient passage may be given to discharge the water. In this way, the draining of such grounds as lie above or near to mines or pits may be of great advantage.

4274. *Where a quarry or other pit to be dried (fig. 642. a) is situated above a porous stratum, whether*



of rock or gravel, it may sometimes be drained by boring into the latter (b). In this way different chalk pits and lime quarries have been

drained in Kent and Hertfordshire. (*See the Reports of these Counties.*) In marl-pits also, which, from the nature of their situation, mostly require much cutting through some part of their sides, in order to remove the water that prevents their being wrought, the mode of letting the water down by means of pits dug through the upholding stratum below the bed of marl into the porous materials underneath, might be economically practised. In such cases, the number of the pits must be proportioned to the space occupied by the marl; and when they are required to be of such depths as to be liable to give way, they should be built up, or nearly filled with loose stones, so as to admit the water to pass off, such lateral drains as are necessary communicating with them. In some situations of the pits, as where the bank slopes lower on the contrary side than the level of the water, an easier mode may be practised; such as by forming a drain in it, and then perforating with a horizontal boring-instrument into the terminating part of the stratum that holds the water; thereby removing and keeping it below the level of the marl. In addition to these, in some cases, as where the water of such pits proceeds from springs in the high grounds above them, it may be useful to intercept and convey it away before it reaches the marl-pits.

4275. *The drainage or drying up of lakes or ponds comes occasionally within the practice of the drainer, especially in countries with an irregular surface. There are, perhaps, few natural lakes indeed, the surface of the water of which might not be very considerably lowered, by deepening their natural outlets, the consequence of which would be, in many cases, a very considerable accession of generally rich land round their margins, a better drainage for the surrounding country, and an improved climate. Much, it is said, might be done in this way in Ireland; but there can be no doubt that in every country in the world a great deal may be done. In flat countries nearly on a level with the sea, like Holland and parts of the counties of Cambridge and Huntingdon, the water will in general require to be raised by machinery; but in by far the greater number of cases, deepening the natural outlet will be found amply sufficient.*

4276. *Bar Loch, in the county of Renfrew, was reduced in size by drainage and embanking, in 1814, at an expense of nearly 10,000*l.*, which has since returned 13 per cent. per annum; 280 acres have been laid dry upwards of 200 of which have been since under crop. A very interesting account of this drainage will be found in the *Highland Society's Transactions*, vol. vii. p. 375.*

4277. *Steam-engines have lately been employed, both in Cambridgeshire and Lincolnshire, as substitutes for the very uncertain power of wind, to raise the water from the low lands, and deliver it into the drains and rivers by means of scoop wheels working like a grinding-stone in its trough. Wheat and other corns have thus been sown on lands never before ploughed. The improvement indeed is one of the greatest that has taken place in fenny countries, since they were first attempted to be drained and embanked. (*Mech. Mag.* vol. v. p. 179. and *Gard. Mag.* vols. *iv.* and *v.*)*

SECT. VII. *Formation of Drains, and Materials used in filling them.*

4278. *Drains should be formed with as much truth and exactness as possible: such labourers as are not dexterous in using their tools seldom make them well. The most general method of performing this sort of work is by admeasurement, at so much a rod, or a score of rods, which necessarily induces the workmen to do as much as they possibly can: they should, therefore, be frequently inspected, to see that they keep to the proper and required depth, that the earth taken out be laid in such a manner as not to fall down again into the drains in time of filling them, and that the surface mould be kept on one side free from the clayey or other material of the inferior stratum.*

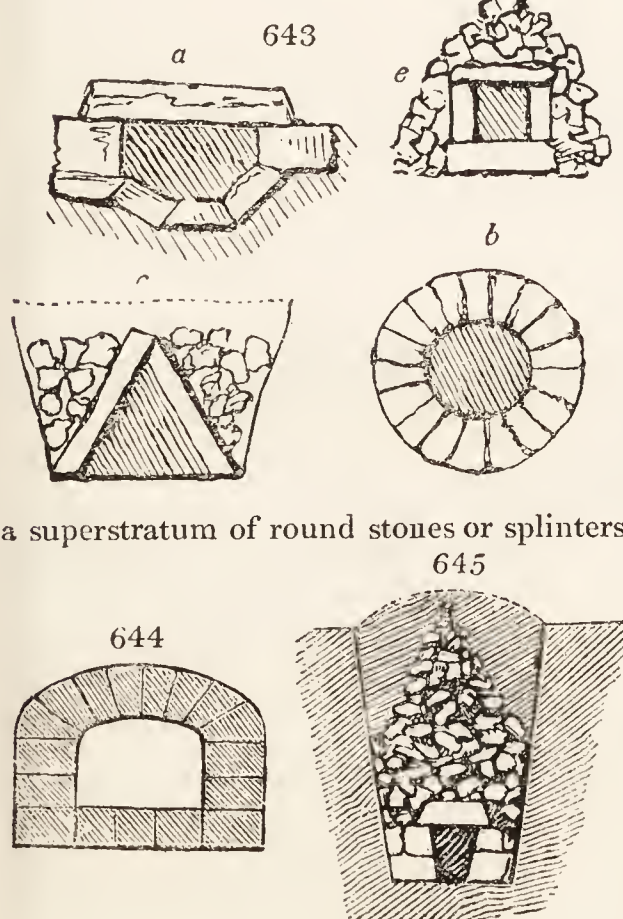
4279. *When there is any declivity in the ground, drains should be made in a slanting direction across it, instead of the old method of conducting them according to the nature or inclination of the slope. By attending to the former mode of cutting the drains, the wetness is not only more effectually removed, but, by allowing the water to pass away in an easy current, they are rendered less liable to be choked, or, as it is frequently termed, blown up, by which artificial ooings of water are sometimes formed in such places. But where grounds are either quite or nearly level, it has long been a general practice to cut the drains at the different distances of about sixteen, twenty-four, and*

thirty-two feet from each other, across the fields from the different ditches, according to the circumstances of the lands; or, indeed, where the drains, either from some slight unevenness of the surface, or other causes, can only be made to flow at one end, to avoid cutting them further on one side than where the ditch is capable of taking away the wetness. In cases where the declivities of a piece of ground are various, and have different inclinations, the drainer should constantly attend to them, and direct the lines of his drains in such a manner as that they may cross the higher sides of the different declivities in a slanting direction.

4280. *The depth of drains* must depend upon the nature of the soils, the positions of the land, and a great variety of other more trifling circumstances. It was formerly the custom to make them three or four feet in depth, but by modern drainers the most general depth is two and a half to three feet. As the main drains have more water to convey away, and are generally of greater length than the lateral ones, they should always be cut somewhat deeper; and where the materials of the soils are porous, the deeper they are cut, the more extensively they act in lowering the wetness of the land: when, however, the operator reaches any material through which the moisture cannot pass, it will be useless to dig the trench to a greater depth. If it be clay, by going a few inches into it, a more safe passage for the moisture may however be secured. It must notwithstanding be invariably attended to, that the depth of the drains be such as that the treading of heavy cattle may not displace, or in any way injure, the materials employed in constructing or filling them. It may be noticed too, where the horses in ploughing tread in the bottom of the furrow, at the depth of four inches or more below the surface, that, if eight or ten be allowed for the materials with which the drains are filled, when the depth of the trenches does not exceed twenty-four inches, there will only be nine or ten inches of earth for the support of the horses when ploughing. Where the earth has been stirred, such a depth must undoubtedly be too little, and this in some measure proves that drains of such a depth are not sufficient. By cutting them down to the depth of two feet and a half in the stiffer soils, they will seldom be penetrated to, or have too great a depth; and in the pervious ones a still greater depth is highly useful, and constantly to be practised.

4281. *Cutting the drains as narrow as possible*, which has of late been much practised, is of importance, as it causes a considerable saving of the matters employed in filling them up, whether wood or straw; but in cases where bricks or stones are used, this cannot be so much attended to; however, a greater width than about a foot is seldom necessary, provided the stones be coupled at the bottom, or thrown in in a mixed way; nor more than sixteen inches where laid in the manner of a sough or channel. But of whatever depth the materials may be, the earth or mould by which they are covered up should not be less in depth than a foot; in arable lands it should be more.

4282. *The different sorts of drains in use* may be classed in two divisions; drains of conveyance (*fig. 643. a, b,*) alone, and drains of conveyance and collection jointly. (*fig. 643. c, d.*) In the former, all that is necessary is a channel or passage for the water, of sufficient dimensions, which may be formed by pipes of different kinds, arched or barrel drains (*b*), and box or walled drains (*a*). The construction of the latter requires not only an opening for conveying the water, but a superincumbent or surrounding stratum (*e, f,*) of sufficient porosity to permit and induce all latent water to find its way to the channel of conveyance. The most complete drain of conveyance is a large pipe of metal, masonry, or brick-work; and the most complete collecting drain, one formed of a channel built on the sides, and covered with flat stones, with a superstratum of round stones or splinters, diminishing to the size of gravel as they rise to the surface, and there covered with the common soil. As the best constructions, however, are not always practicable, the following are a few of the leading sorts adapted for different situations.

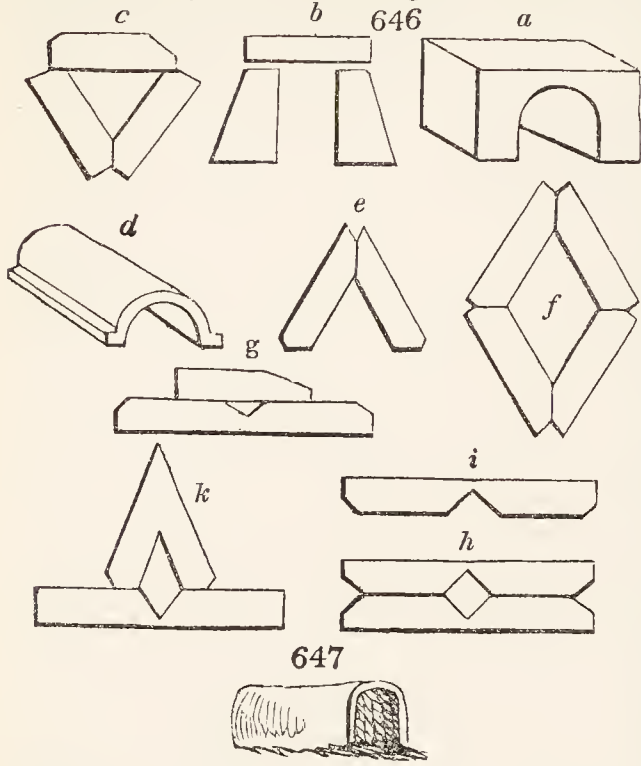


4283. *For drains of conveyance*, there are the walled or box drain (*fig. 643. a*), the barrel drain (*b*), the walled or the triangular drain (*c*), and arched drain. (*fig. 644.*)

4284. *Drains of collection* are formed of stone, brick, gravel, cinders, wood, spray, straw, turf, and earth alone.

4285. *The boxed and rubble drain* (*fig. 644*) has been already described as a drain of conveyance and col-

lection. The common rubble drain is formed of rough land-stones of any sort, broken so as not to exceed two or three inches in diameter. No good drainer uses stones six or eight inches in diameter in any part of a rubble drain, least of all at the bottom. The point kept in view is to use such small stones at the bottom as may allow the water a great many channels; so that, if a few should become impermeable, there should be many others remaining. The nearer the bottom of a drain of this kind approaches to the character of a natural bed of gravel, the more certain will be the free passage of the water. Gravel or ashes should be laid on the top of the stones, on these a thin layer of straw or haulm of any kind, and the remainder filled up with the surface soil.

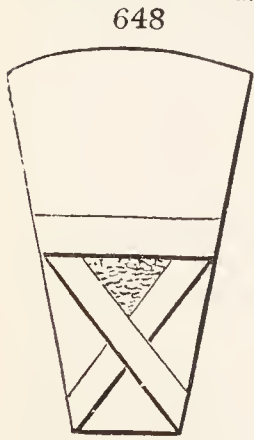


4286. *The brick drain* is formed in a great variety of ways, either with common bricks and bats in imitation of the boxed and rubble, or rubble drain; or with bricks made on purpose, of which there is great variety. (fig. 646. a to k.) Draining tiles, to be used with effect as collecting drains, should generally be covered a foot in depth or more with stones or gravel. But if the land to be drained be in grass, laying the sod over the tile is sufficient: if the land be not in grass, and be loose in texture, a little straw may be profitably laid over the tile, to prevent the soil from running in. The pantile (d) is the best for general purposes, but ought not to have holes at top; but sometimes such holes are made. In very loose soils, plain tiles are wanted to place the draining tiles on: in other soils, old broken pieces of plain tiles are sufficient for the ends to rest on. Sometimes, even at depths of six feet, these tiles, though of five inches in the clear, will be entirely blocked up by the fibrous roots of trees, especially of the black poplar. A variety of this tile, of a more ample capacity, has lately been brought into use in Lincolnshire. (fig. 647.) The best draining tiles in England are manufactured at the Staffordshire potteries; and Peake, of Tunstall, may be named as eminent in this line. (*Gard. Mag.* vols. v. and vi.)

4287. *On the Marquis of Stafford's estate*, "an allowance of draining tiles is made, wherever the exertions of the tenants seem to merit such a reward. In order to secure the drains being properly filled up with stones above the tiles, the tenant is obliged to drive a sufficient quantity of stones or cinders from the furnaces, and lay them on the ground, previously to an order being made for the delivery of the tiles. Without attending to this important circumstance, much draining would be thrown away. The park at Trentham is a complete illustration of this remark. The draining of this spot was conducted under the direction of Elkington. The wetness with which these lands are affected does not arise from any line of springs bursting out from the upper grounds, to which that gentleman's system of deep drains could be applied; but is occasioned almost entirely by the retentive nature of the subsoil, and by its being intermixed with small basins of sand, which lie detached and unconnected with each other, in the bed of clay. To cure this species of wetness, a number of small drains, well filled up, with one cut into each of these beds of sand, is necessary. In pursuance of this plan, a great part of the park at Trentham has been lately drained over again, by making a number of small shallow drains, about fifteen feet asunder, in some instances above the old ones, taking particular care to fill them up as well as possible, and not to permit any clay to be laid over the stones. This has proved effectual." (*Loch.*)

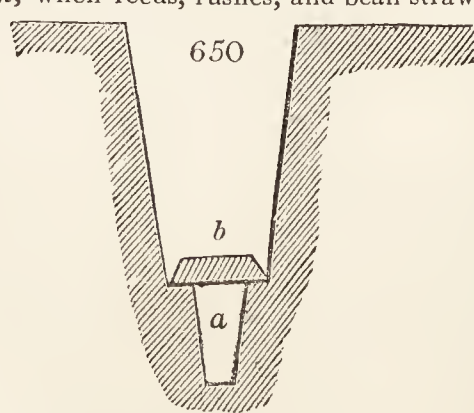
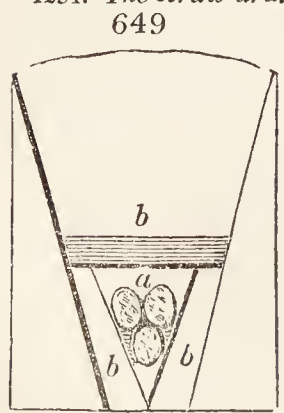
4288. *The gravel or cinder drain* is seldom made deep, though, if the materials be large, they may be made of any size. In general they are used in grass lands; the section of the drain being an acute-angled triangle, and the materials being filled in, the smallest uppermost, nearly to the ground's surface.

4289. *The wood drain* is of various kinds. A very sufficient and durable construction consists of poles or young fir-trees stripped of their branches and laid in the bottom of the drain lengthways. They are then covered with the branches and spray. Another form is that of filling the drain with faggot-wood with some straw over. A variety of this mode (fig. 648.) is formed by first setting in cross stakes to prevent the faggots from sinking; but they are of no great use, and often occasion such drains to fail sooner than common faggot drains, by the greater vacuity they leave after the wood is rotten. In some varieties of this drain the brushwood is first laid down alongside the drain, and formed by willow or other ties into an endless cable of ten or twelve inches in diameter, and then rolled in; which is said to form an excellent drain with the least quantity of materials, and to last a longer time than any of the modes above mentioned. Some cut the brushwood into lengths of three or four feet, and place them in a sloping direction with the root end of the branch in the bottom of the drain; others throw in the branches at random, with little preparation, and cover them with spray, straw, or rushes, and finally the surface soil.



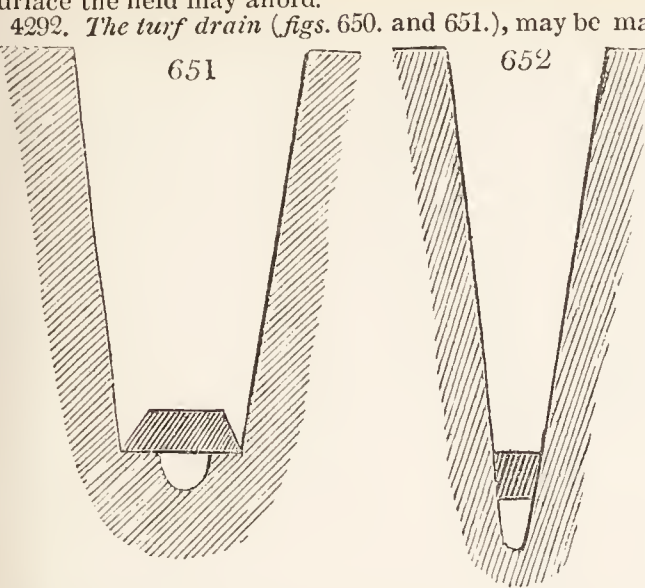
4290. *The spray drain* is generally, like the gravel drain, of small size, and formed, like it, with an acute-angled bottom. In general, the spray is trod firmly in; though in some cases it is previously formed into a cable, as in the brush-wood drain. Drains of this sort are much in use in grass lands, and when the spray of larch wood, heath, or ling can be got, they are of great durability.

4291. *The straw drain*, when reeds, rushes, and bean straw are used, is sometimes made like the spray drain, by pressing the loose material down, or forming a cable; but in general the straw is twisted into ropes as big as a man's leg, by the aid of a machine (2562.), and three or more of these (fig. 649. a) laid in the bottom of a triangular drain, with or without the protection of three turves (b). Where some sorts of moss, as Sphagnum or Lycopodium, can be got, these drains are of unknown durability. Drains formed in this manner, through tough and retentive clays, will be found, in a short time after the work is finished, to have formed over the straw with which the drain was filled, an arch of sufficient strength to support the incumbent weight of the soil and the casual traffic of the field. In twelve or eighteen months it may be observed that the straw, being of one uniform substance, is all rotted and carried away, leaving a clear pipe through the land in every drain. The passage of the water into these drains



eighteen months it may be observed that the straw, being of one uniform substance, is all rotted and carried away, leaving a clear pipe through the land in every drain. The passage of the water into these drains

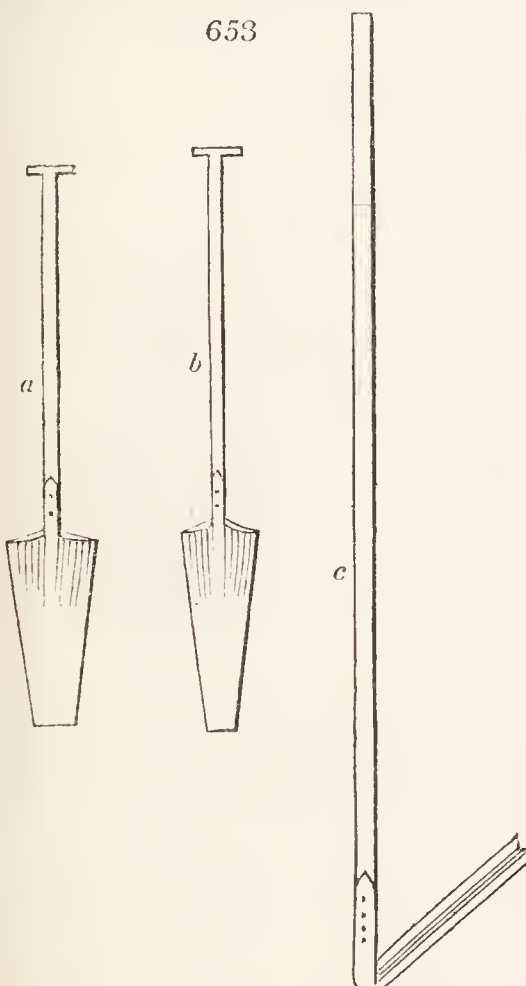
may be much facilitated by a due attention to filling them with the most friable and porous parts of the surface the field may afford.



4292. *The turf drain* (figs. 650. and 651.), may be made of any convenient depth, but it must be at least the breadth of a turf at bottom. The drain being dug out as if it were to be filled with stones or any ordinary material; the operator next, with a spade three inches wide, digs a narrow channel along its centre (a), clearing it out with the draining scoop; and over this the turves (b) are laid without any other preparation, or any thing put over them but the earth that was excavated. This is found to be a very cheap, and, considering the materials, a surprisingly durable method of draining; answering, in pasture-fields especially, all the purposes that the farmer can expect to derive from drains constructed with more labour, and at a much greater expense. They are said to last frequently twenty years and upwards: but the period which it can be supposed they will continue to prove effectual, must depend on the nature of the soil and the current of water.

4293. *The wedge or triangular sod drain* (fig. 652.) is thus made:— When the line of drain is marked out, a sod is cut in the form of a wedge, the grass side being the narrowest, and the sods being from twelve to eighteen inches in length.

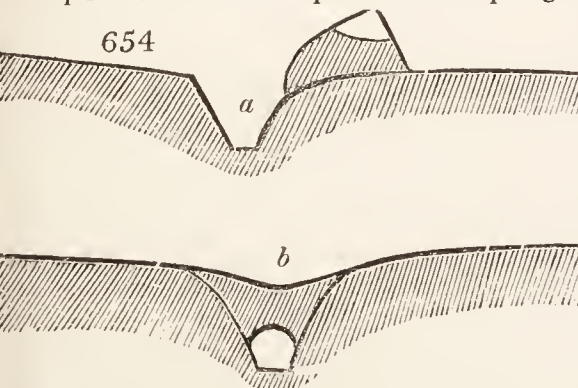
The drain is then cut to the depth required, but is contracted to a very narrow bottom.



then set in with the grass side downwards, and pressed as far as they will go. As the figure of the drain does not suffer them to go to the bottom, a cavity is left which serves as a watercourse; and the space above is filled with the earth thrown out. The work is performed by means of three spades of different sizes. The first may be a common spade of moderate breadth, with which the surface clay may be taken off to the depth of eight or ten inches, or not quite so much, if the clay be very strong. The breadth of the drain, at top, may be from a foot to fifteen inches; but it never should be less than a foot, as it is an advantage that the sides should have a considerable slope; and the two sides should slope as equally as possible. Another workman follows the first, with a spade six inches broad at the top, and becoming narrower towards the point, where it should not exceed four inches. (fig. 653. a.) The length of the plate of this second spade should be fourteen inches, and with it a foot or fourteen inches in depth can easily be gained. A third workman, and he should be the most expert, succeeds the second, and his spade should be four inches broad at top, only two inches broad at the point, and fourteen or fifteen inches in length (b). With this spade a good workman can take out at least fifteen inches of clay. A sort of hoe or scoop, made of a plate of iron, formed nearly into the shape of a half cylinder of two inches diameter, and a foot or fourteen inches long, and fastened, at an acute angle of perhaps 70°, to a long wooden handle (c), is now employed to scrape out the bottom of the drain, and remove any small pieces of clay that may have fallen into it. The grassy side of the turf being turned undermost, they are put down into the drain, the workman standing upon them after they are put in, and pressing them down with his whole weight till they are firmly wedged between the sloping sides of the drain. The ends of the turfs being cut somewhat obliquely, they overlap each other a little; and by this means, although there is sufficient opening for the surface water to get down, nothing else can. The open space, below the turf, ought to be five or six inches in depth, three inches wide at top, and an inch and a half or two inches at bottom. (Trans. Highl. Soc. vol. vi. p. 571.)

4294. *The hollow furrow drain* is only used in sheep-pastures. Wherever the water is apt to stagnate, a deep furrow is turned up with a stout plough (fig. 654. a).

After this, a man with a spade pares off the loose soil from the inverted sod, and scatters it over the field, or casts it into hollow places. The sod, thus pared, and brought to the thickness of about three inches, is restored to its original situation, with the grassy side uppermost, as if no furrow had been made (b). A pipe or opening two or three inches deep is thus formed beneath it, in the bottom of the furrow, sufficient to discharge a considerable quantity of surface water, which readily sinks into it. These furrows, indeed, are easily choked up by any pressure, or by the growth of the roots of the grass; but they are also easily restored, and no surface is lost by means of them.

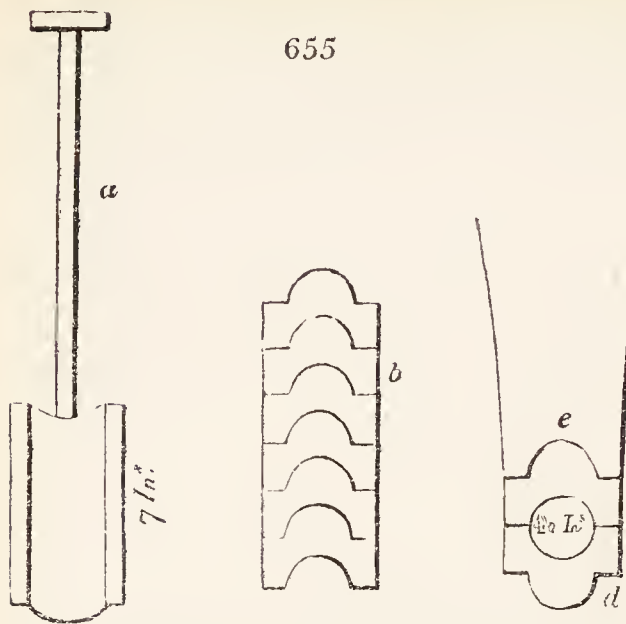


4295. *The earth drain*, called also *the clay-pipe drain*, is better calculated for the purpose of an aqueduct, or conveyance of water, than for drying the soil. A drain is dug to the necessary depth, narrow at bottom, in

which is laid a smooth tree or cylindrical piece of wood, ten or twelve feet long, six inches in diameter at the one end, and five at the other, having a ring fastened in the thickest end. After strewing a little sand upon the upper side of the tree, the clay or toughest part of the contents of the trench is first thrown in upon it, and then the remainder, which is trod firmly down. By means of the ring and a rope through it, the tree is drawn out to within a foot or two of the small or hinder end, and the same operation repeated. A gentleman who has tried this experiment says, this clay pipe has conducted a small rill of water a considerable way under ground for more than twenty years, without any sign of failing.

4296. *Pipe drains of turf* are sometimes formed

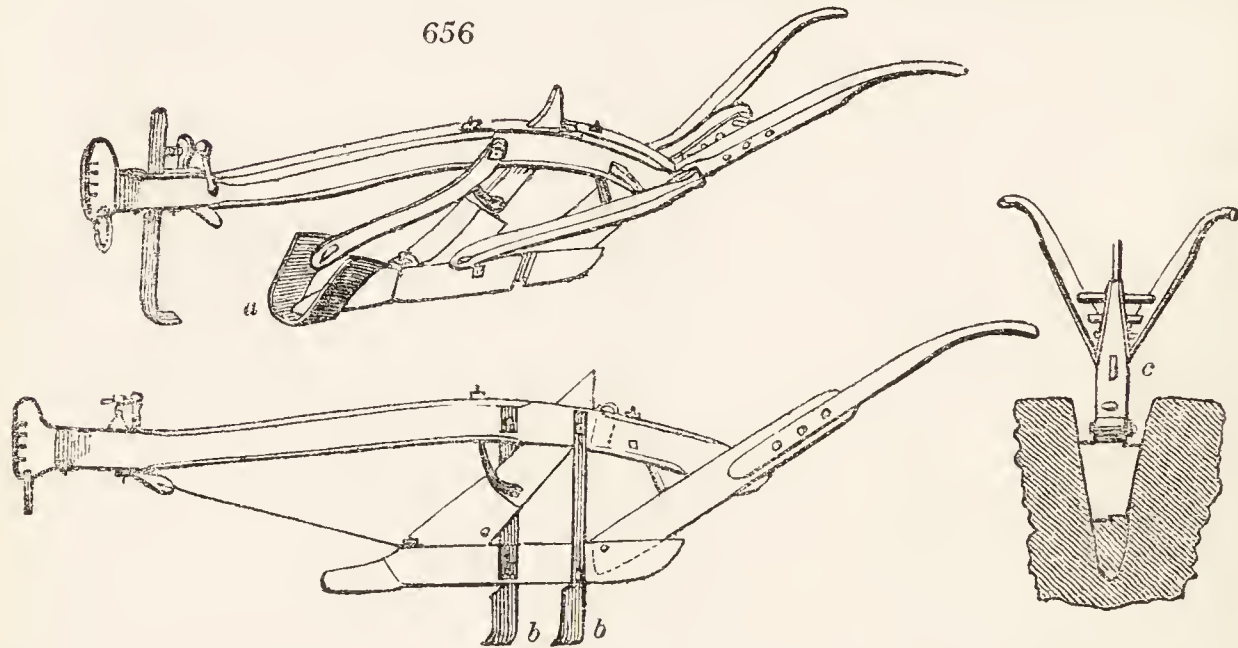
where the surface soil is a strong clay, as it is only turves from such a surface that are sufficiently durable. A semicylindrical spade (*fig. 655. a*) is used to dig the turves, the ground-plan of which (*b*) presents a series of semicircles or half pipes. The drain (*c*) being dug out to the proper depth, one turf is laid in the bottom (*d*); and another being placed over it (*e*), completes the pipe. The same sort of pipe drain has been formed out of solid beds of clay, and has served for a time to convey water. As collecting drains, of course, they can be of little or no use. Hannay, an ingenious farmer in Wigtonshire, adopted this mode for the purpose of conveying water through running sand, in which only a pipe drain will last for a moderate time. After a number of years the clay turves were found effective in conveying away the water, and preventing the running away of the sandy sides of the drain.



4297. *Pearson's method of pipe-draining* will be found described at length in the *Transactions of the Society of Arts*, vol. xlvii. for 1829. The ground is first opened by a plough, with what is called a horn-share. (*fig. 658.*) With four horses and the horn-share (*a*), a furrow nine or ten inches deep by ten inches is taken out. The horns are then removed, the coulters (*b b*) added, and eight horses attached. This cuts the soil to an additional depth

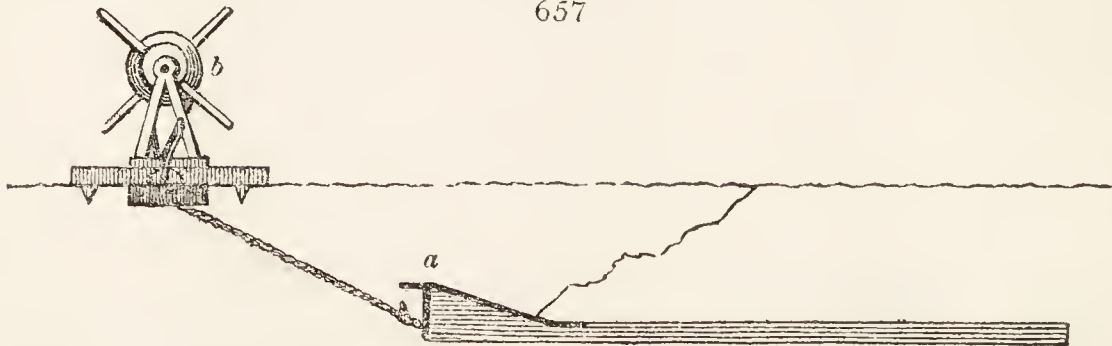
of ten inches (*c*), and it is immediately removed with narrow spades, and larger and smaller draining

656



scoops. (*figs. 653. c, and 661. a, b.*) A second pair of coulters cuts the soil to the depth required, which is also taken out by the scoops. The total depth is now about twenty-six inches, the width at top ten inches, and at bottom about one inch. A slide (*fig. 657. a*) is then dropped to the bottom of the drain,

657



commencing at its lowest level, so as to work up hill. A windlass (*b*) is next placed at the full length of the rope, which is attached to the slide. Clay is next rammed firmly down on the slide with a heavy rammer to the depth of three or four inches, and the slide is next pulled forward, leaving a cylindrical drain of three or four inches in diameter, according to the diameter of the slide. (*Trans. Soc. Arts*, vol. xlvii. p. 30.)

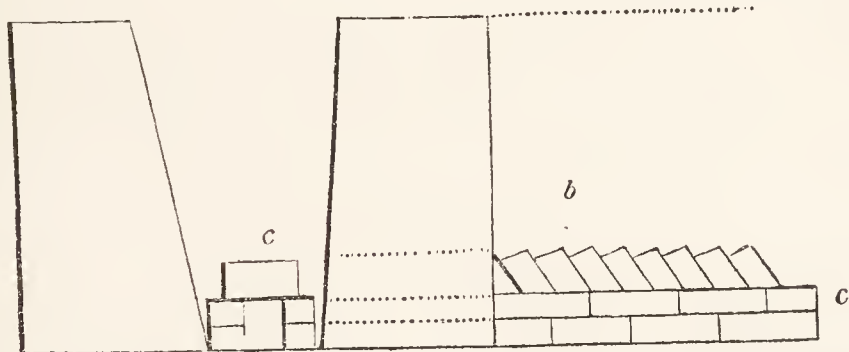
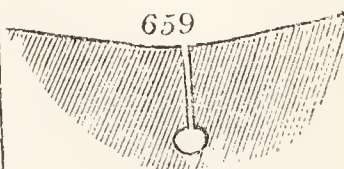
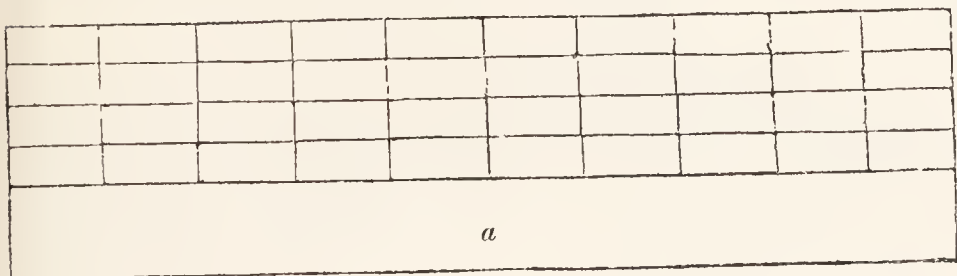
4298. *A mode of turf-draining in use in Cheshire* is as follows:—The surface of the ground where the drain is intended to be cut, is marked out in parallelograms about the size of bricks on one side (*fig. 658. a*), and that opposite is left of the width of a common sod; *i. e.* nine inches wide. These sods are taken out at a spade's depth, and laid carefully by the side of the drain for covers. The sods (*a*), resembling bricks in their size and shape, are then dug, and laid carefully on the same side as the sods intended for covers. The drain is then sunk to its proper depth, and the stuff taken out is thrown to the other side. The bottom is levelled with proper draught for the water, and set with the sods like bricks (*a*), two in height on each side (*c*); these are covered with the larger sods set obliquely (*b*), the grass side of each sod being turned downwards. (*Agr. Rep. of Cheshire*, 214.)

4299. *The mole drain* (*fig. 659.*) is formed by the draining-plough of that name already described (2643.) with the manner of using it. It is chiefly useful in pasture-lands, and especially in such as have some declivity, or are formed into ridges.

4300. *The wheel drain* is a very ingenious invention, described in *The Agricultural Report of the County of Essex*. It consists of a draining-wheel of cast-iron, that weighs about 4 cwt. It is four feet in diameter; the cutting-edge or extremity of the circumference of the wheel is half an inch thick, and increases in

thickness towards the centre. At fifteen inches deep it will cut a drain half an inch wide at the bottom, and four inches wide at the top. The wheel is so placed in a frame, that it may be loaded at pleasure, and made to operate to a greater or less depth, according to the resistance made by the ground. It is used in winter when the soil is soft; and the wheel tracks are either immediately filled with straw ropes, and lightly covered over with earth, or they are left to crack wider and deeper till the ensuing summer; after which the fissures are filled with ropes of straw or of twisted twigs, and lightly covered with the most porous earth that is at hand. Thus, upon grass or ley lands, hollow drains, which answer extremely well, are formed at a trifling expense. It is said that twelve acres may be fully gone over with this draining-wheel in one day, so as to make cuts at all necessary distances.

658



4301. *Surface-gutters made by cart-wheels* have been used by Middleton, on meadows in Surrey. To the felly of a common cart-wheel (*fig. 660. a*), is added a piece of wood, the section of which is a truncated triangle (*b*), and on this is fixed a piece of iron completing the triangle (*c*). The cart is loaded and driven so as the prepared wheel may run in the furrow; or, if there are no furrows, both wheels may be prepared, and the loaded cart drawn by two horses, may be led over the whole field, forming parallel gutters, four or five feet distant. The advantage of this mode of surface draining is, that the herbage is only pressed down, not destroyed, and rises up again in spring. The operation, for that reason, requires to be renewed every winter. It certainly seems a barbarous mode, but it may have answered better than one who has never seen it practised might be led to imagine.

4302. *In forming small drains, chiefly for retentive soils*, the common plough has been used in many places, and with some advantage. The method practised by Young, as described in *The Annals of Agriculture*, is this:—When he has marked the drains in a field usually a rod asunder, he draws two furrows with a common plough, leaving a baulk betwixt them about fifteen inches wide; then with a strong double-breasted plough, made on purpose, he splits that baulk, and leaves a clean furrow fourteen or fifteen inches below the surface; but where the depth of soil requires it, by a second ploughing he sinks it to eighteen or twenty inches: it is then ready for the land-ditching spade, with which he digs, fifteen inches deep, a drain as narrow as possible. But the method followed by some farmers, who do not possess ploughs made on purpose for the work, is this—With their common plough, drawn by four or five horses, and usually stirring about four or five inches deep, they turn a double furrow, throwing the earth on each side, and leaving a baulk in the middle. This baulk they raise by a second bout, in the same manner: then they go in the open furrow twice, with their common double-breast plough, getting what depth they can. After this they shovel out all the loose mould and inequalities to the breadth of about a foot; and thus having gained a clear open furrow, the depth varying according to the soil and ploughs, but usually about eight or nine inches, they dig one spit with a draining spade sixteen inches deep, thus gaining in the whole twenty-four or twenty-six inches. But as this depth is seldom sufficient, when necessary they throw out another, or even two other spits, which makes the whole depth from thirty to forty inches.

4303. *The best season for marking out and forming drains* is the spring or beginning of summer; because then the land springs, being still in vigour, are more easily discovered and traced than at a later period. When the ground is soft on the surface, it is a useful precaution, after the line is indicated, to cart on the materials for filling before digging the drain, as the weight of the carriages and horses is apt to press in the sides. In the case of straw, turf, or earth drains, where the ground is of a firm texture, this precaution does not apply. In filling drains, the earth should always be raised somewhat above the general surface, to make allowance for sinking.

4304. *The duration of drains* must necessarily depend on the nature of the materials with which they are filled, and in some measure on the quality of the soil, as certain species of land have the power of preserving wood or other perishable materials much longer than others. Stones last till accidental causes impede the flowing of the water, and may last for ever. Wood perishes in certain periods, but it does not follow that the drains should stop; if the earth arches, the water will necessarily continue to flow, which is found to be the case when wood, straw, and stubble are rotten and gone. Drains that have been filled with bushes and straw, both which were rotten, have been observed to run well forty years after making.

4305. *The expense of drains* will of course vary with the soil, depth, price of labour, &c.; and these circumstances are so different in different districts, and even in different parishes, that it accounts for the various reports of writers on the subject. Those farmers who are most solicitous to have the work well performed, contract with men only for digging and leaving clean, in order that the filling may be done by men paid by the day,

as a greater security that it should be executed with all possible care. Whatever may be the expense and trouble incurred in draining, it may be safely asserted that, if the work is judiciously contrived and properly executed, no kind of outlay will prove so beneficial to the cultivator.

4306. *The enemies of drains*, according to Marshal, are moles, field mice, and the roots of trees: the first two may be kept under by traps or other devices; but the last enemy is not easily guarded against, except in the laying out of the drain, which should always, if possible, be kept distant from trees or woody plants of any description.

SECT. VIII. *Of the Implements peculiar to Draining.*

4307. *The tools peculiar to draining* are chiefly of the spade kind: there are also boring instruments of different kinds.

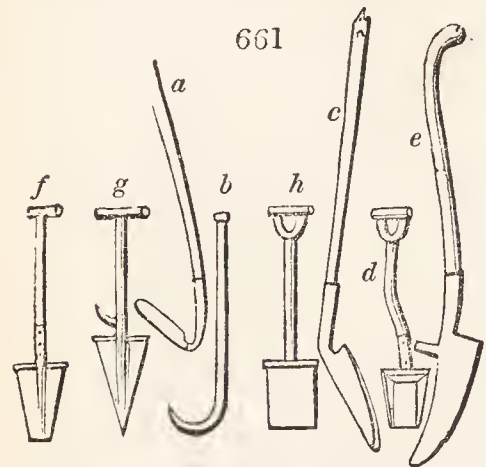
4308. *The draining-scoop* (fig. 661. *a, b, c,*) is a crooked kind of tool made use of in some cases for clearing out the loose materials from the bottoms of drains. It is formed of different sizes and breadths, according to the drains, and in working is drawn or pushed along the bottom.

4309. *The draining shovel* (*d*) is another sort of implement employed for the same purpose as the above. It is made with a crooked handle, and the edge of the shovel part is turned up, in order to prevent the materials from falling off.

4310. *The draining sod knife* (*e*) is an implement made use of with great benefit in scoring or cutting out the sward in forming drains.

4311. *Draining spades* (*f, g, h,*) are made of different breadths, so as to follow each other, and cut the drains narrow at the bottoms. An upper and pointed draining spade (*g*) is in general use, and a wooden one (*h*) is employed in peat soils.

4312. *The draining straw-twisting engine* is a machine of very simple construction, already described (2562.), and capable of being readily removed, contrived for the purpose of twisting straw into ropes for the filling of drains.



4313. *A variety of boring implements, including Good's and the peat-borer*, have been already described. (2507. to 2519.)

4314. *The common draining auger* (fig. 662.) consists of four parts, the shell or wimble, the chisel, the rod, and the handle. The auger shell, or wimble (*e*), as it is variously called, for excavating the earth or strata through which it passes, is generally from two and a half to three and a half inches in diameter; the hollow part of it one foot four inches in length, and constructed nearly in the shape of the wimble used by carpenters, only the sides of the shell come closer to one another. The rods (*a*) are made in separate pieces of four feet long each, that screw into each other to any assignable length, one after another, as the depth of the hole requires. The size above the auger is about an inch square, unless at the joints (*b*), where, for the

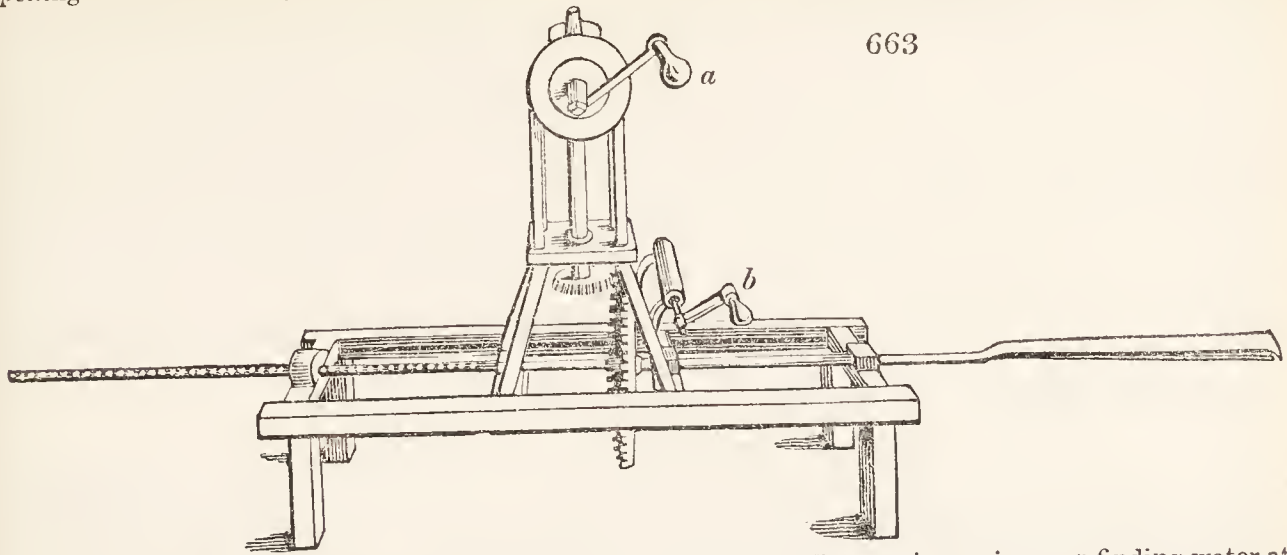
sake of strength, they are a quarter of an inch more. There is also a chisel and punch (*b*), adapted for screwing on in going through hard gravel, or other stony substances, to accelerate the passage of the auger, which could not otherwise perforate such bodies. The punch is often used, when the auger is not applied, to prick or open the sand or gravel, and give a more easy issue to the water. The chisel is an inch and a half or two inches broad at the point, and made very sharp for cutting stone; and the punch an inch square, like the other part of the rods, with the point sharpened also. There is a shifting handle of wood (*d*), fastened by means of two iron wedges affixed to it, for the purpose of turning round the rods in boring; and also two iron keys (*f, c*), for screwing and unscrewing the rods, and for assisting the handle when the soil is very stiff, and more than two men required to turn it.

4315. *To judge when to make use of the borer* is a difficult part of the business of draining. Some have been led into a mistaken notion, both as to the manner of using it and the purpose for which it is applied. They think that if, by boring indiscriminately through the ground to be drained, water is found near enough the surface to be reached by the depth of the drain, the proper direction for it is along these holes where water has been found; and thus they make it the first implement to be used. The contrary is the case; and the auger should never be used till after the drain is cut; and then for the purpose of perforating any retentive or impervious stratum, lying between the bottom of the drain and the reservoir or strata containing the spring. Thus does it greatly lessen the trouble and expense that would otherwise be requisite in cutting the trench to a depth which, in many instances, the level of the outlet will not admit.

4316. *The manner of using it* is simply thus:—In working it, two, or rather three men are necessary. Two, standing above, one on each side of the drain, turn the auger round by means of the wooden handles, and when it is full they draw it out; and the man in the bottom of the trench clears out the earth, assists in pulling it out, and directing it into the hole, and he can also assist in turning with the iron handle or key, when the depth and length of rods require additional force to perform the operation. The workmen should be cautious, in boring, not to go deeper at a time, without drawing, than the exact length of the shell; otherwise the earth, clay, or sand through which it is boring, after the shell is full, makes it very difficult to pull out. For this purpose the exact length of the shell should be regularly marked on the rods, from the bottom upwards. Two flat boards, with a hole cut into the side of one of them, and laid side by side across the drain, are very useful for directing the rods perpendicularly in going down, for keeping them steady in boring, and for the men to stand on when performing the operation.

4317. *The horizontal auger* (fig. 663.) is another boring instrument employed in particular cases. It was invented by Halford, of Hathern, in Leicestershire, but is little used. The advantages of it are, in some cases, considerable, by lessening the expense of cutting, and performing the work in a much shorter time. Where a drain or water-course has to pass under a bank, road, hedge, wall, rivulet of water, or for

drying marl-pits, &c., it may be used to advantage in excavating a sufficient passage for the water, without opening a trench. In laying leaden pipes for the conveyance of water, it is also useful in making a hole



in which the pipe may be laid, without opening a cut on purpose. For tapping springs, or finding water at the bottom of a hill, either for the supply of a house, or for draining the ground, it may likewise be used with success; as the water of the spring, when hit on, will flow more easily and in greater abundance through a horizontal or level, than through a perpendicular outlet.

4318. *The manner of using it is this* :— Suppose a lake or pond of water, surrounded with high banks, to be emptied, if the ground declines lower on the opposite side, find the level of the bank where the perforation is to be made. There smooth the surface of the ground so as to place the frame nearly level with the auger, pointing a little upwards. It requires two men to turn the handles at top (*a*), in order to work it; and when the auger or shell is full, the rods are drawn back by reversing the lower handle (*b*). Other rods are added at the joint when the distance requires them. In boring through a bank of the hardest clay, two men will work through from thirty to forty feet in a day, provided there is no interruption from hard stones, which will require the chisel to be fixed on in place of the shell, and longer time to work through. If the length to be bored through is considerable, or longer than the whole length of the rods, a pit must be sunk upon the line, down to the hole, for placing the frame when removed, and the operation carried on as before.

CHAP. II.

Embanking and otherwise protecting Lands from the Overflowing or Encroachment of Rivers or the Sea.

4319. *Lands adjoining rivers or the sea* are frequently liable to be overflowed or washed away, or to be injured by the courses of rivers being changed during great floods. These evils are guarded against by embankments and piers; or by these constructions joined to deepening or straightening the courses of rivers, and we shall therefore treat in succession of embankments and of improving the courses of rivers.

SECT. I. *Embanking Lands from Rivers or the Sea.*

4320. *The great value of alluvial soil* to the agriculturist no doubt gave rise to the invention of banks, or other barriers, to protect soils from the overflowing of their accompanying rivers. The civilised nations of the highest antiquity were chiefly inhabitants of valleys and alluvial plains; the soil, moisture, and warmth of which, by enlarging the component parts and ameliorating the fruits of the vegetable kingdom, afforded to man better nourishment at less labour than could be obtained in hilly districts. The country of Paradise and around Babylon was flat, and the soil saponaceous clay, occasionally overflowed by the Euphrates. The inhabited part of Egypt was also entirely of this description. Historians inform us that embankments were first used by the Babylonians and Egyptians, very little by the Greeks, and a good deal by the Romans, who embanked the Tiber near Rome, and the Po for many stadia from its embouchure. The latter is perhaps one of the most singular cases of embankment in the world.

4321. *The oldest embankment in England* is that of Romney Marsh; as to the origin of which, Dugdale remarks, "there is no testimony left to us from any record or historian." (*History of Embanking and Draining.*) It is conjectured to have been the work of the Romans, as well as the banks on each side of the Thames, for several miles above London, which protect from floods and spring tides several thousand acres of the richest garden ground in the neighbourhood of the metropolis. The commencement of modern embankments in England took place about the middle of the seventeenth century, under Cromwell. In the space of a few years previous to 1651, 425,000 acres of fens, morasses, or overflowed muddy lands, were recovered in Lincolnshire, Cambridgeshire, Hampshire, and Kent; and let at from 2s. 6d. to 30s. an acre. (*Harte's Essays*, p. 54, 2d edit.) Vermuyden, a Fleming by birth, and a colonel of horse under Cromwell, who had served in Germany during the thirty years' war, was the principal undertaker of these works. Some farther details of the history of embanking will be found in the

Repertory of Patent Inventions, for January, 1826, and in the *Bulletin des Sciences Agricoles*, for November, 1827.

4322. *Very little has been written on the subject of embankments*, as a separate branch of art, by British authors. Dugdale's work is entirely historical and topographical. But the writings of Smeaton, Young, Gregory, &c., contain the general principles on which is founded the art of embanking, and every other operation connected with water; and Beatson, (in *Communication to Board of Agriculture*,) Dr. Anderson, Marshal, and some others, have written on the practice of the art. The works of this sort constructed in our own times will be found described in the *Agricultural Reports* of the maritime counties, especially of Lincolnshire, by Arthur Young. We shall first submit some general remarks on the principles of designing embankments, and next describe the principal kinds of banks, with their application.

SUBJECT. 1. *General Principles of designing Embankments.*

4323. *The theory of embanking*, Marshal observes, is beautifully simple. The outward waters having been resisted by a line of embankment, and having receded, those that have collected internally are enabled, by their own weight, to open a valve placed in the foot of the bank, and effect their escape: thus securing the embanked lands from inundation, though beset on every side with water.

4324. *The pressure of still water* against the sides of the vessel containing it being as its depth, it follows, that a bank of any material whatever, impervious to water, whose section is a right-angled triangle, and the height of whose perpendicular side is equal to that of the water it is to dam in, will balance or resist this water, whatever may be the breadth of the surface of the latter; and therefore that, as far as width or extent is concerned, it is just as easy to exclude the Atlantic Ocean as a pond or a river of a few yards in width.

4325. *Embankments* may be considered in regard to their situation, direction, construction, and materials.

4326. *The situation of the bank* should be such that its base may not be unnecessarily exposed to the immediate action of the waves or the current; and where the quantity of water is limited, as in the case of land-floods in a particular river, the more room it has to spread, the less height and strength the bank will require; and the power of the current will be proportionably lessened. It is to be recollected, however, in all cases where the channel of the water is liable to be warped or filled up by siltage, that the narrower the space is, in which the water is confined, the stronger will be its current, and the less silt will, in ordinary cases, be deposited.

4327. *The direction of embankment* should be free from sharp angles, so as to occasion the least possible resistance to the current, whether of a land-flood or the tide.

4328. *In the construction or form of the bank* there are certain principles to be observed. Its height and strength ought ever to be proportioned to the depth and the pressure of water which it will have to sustain; and, to increase its firmness, the inner face should lean towards it, as a buttress. But it is on the construction of the outer face its strength, firmness, and durability principally depend. This ought to be made sloping, to a degree of flatness; for the twofold purpose of preventing resistance and taking off the weight of water. In difficult cases, the outer surface may form an angle with a perpendicular line of 45 to 60 degrees, according to the force to be guarded against, and the materials to be employed.

4329. *The materials of the body of the bank* (as well as of the inner face), where the foundation is sound and firm, and the bank can be carried up at a proper season, without great molestation from the water, may generally be the natural soil of the lands to be embanked; and, where merely the weight of stagnant or slowly moving water is to be guarded against, the outer slope may be of the same material. But where force, whether of waves or a strong current, will act immediately upon the bank, its outer face ought to be made proof against it; and its base should be particularly guarded, to prevent its being undermined; the most mischievous and irreparable disaster of embankments. Hence, when the foundation is not sufficiently firm, piles, timber, and masonry may be required, to ensure success; and no man ought to begin a work of this nature without attentively guarding it against every probability of miscarriage.

4330. *A system of drains and floodgates* is requisite for the purpose of freeing the embanked lands from internal waters.

4331. *In designing and setting out the main drain, or discharging channel*, on the outside of the embankment, there are points which require particular attention. The situation of the outfall, or mouth, with respect to the current of the water into which it opens, is of considerable importance. It ought to be such that the current of the water received will not warp up the channel of the drain; but such, on the contrary, as will tend to clear the mouth and keep the channel free. If it were not to preserve the requisite character of an elementary work, it might be deemed unnecessary to add, that the mouth of the discharging drain should be situated as low beneath the floodgate of the embankment as given circumstances and a prudent expenditure will allow; in order that, by inducing a sufficient current, the floodgate, as well as the mouth of the channel, may become free from obstructions. Against the open sea, or a wide estuary, where there is no disgoring channel, but where the waves reach the foot of the embankment, two floodgates may be required: one on the outer side, to sustain the force of the waves, and prevent their blowing up the inner works; the other within, to secure the passage the more effectually. The outer gate in this case is liable to be lifted with the agitation of the waves, and thereby to admit much water; but the inner valve, being in an undisturbed situation, effectually stops its progress.

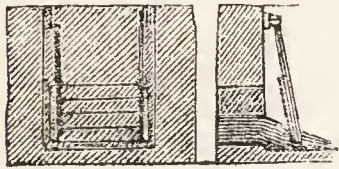
4332. *Where the discharge is made immediately behind a shifting beach*, and especially where the floodgate is necessarily placed level with or beneath the general surface of the gravel bank, through which the waters have been wont to force a channel, the valve is liable to be buried, and the channel to be closed up by every spring tide, and by every gale of wind which sets in upon it; and cannot be kept free but by unceasing labour and expense. In an obstinate case of this kind on Lord Cawdor's estate, in Pembroke-shire, the discharging floodgate is defended by a covered channel, carried out through the line or ridge of beach into the sea; being made strong enough to sustain the weight of the heaviest breakers. This, it is true, has been effected at a great expense, but nevertheless, the improvement being of considerable magnitude, with great profit. In every case where an external valve is required, and where it is liable to be silted up, or loaded with sand or gravel, great attention to the outward channel is necessary, or some defence must be constructed; for the floodgate, when loaded, cuts off all communication between the pent up waters and the materials that impound them. They cannot, by loosening the obstructing matter, as

nature would otherwise direct them, force their way through it; nor, by surmounting it, can they wear down a channel, and thus set themselves at liberty.

4333. *In ordinary cases*, the outer floodgate may be guarded by a pile fence or jetty, run out from the foot of the embankment, across the known drift of the beach; and in such a manner as not to interrupt the outfall channel of the water; the gravel, &c. which such a safeguard may accumulate, being removed from time to time as occasion may require.

4334. *The best construction of the flood-gate* for the uses now under consideration is the common valve, hingeing at the top, swinging outward and falling into a rabbeted frame. In forming and hanging a floodgate of this construction, there are a few particulars worthy of attention. It should be made of seasoned wood, and ought to be double; the boards or planks of which it is formed being made to cross each other, to prevent its casting. It should fall truly, and fit neatly within a surrounding rabbet (to lessen the power of the waves to lift it); but not so closely or tight as to stick when swelled by moisture. To prevent this, as well as to give it additional tightness, its edges should not be square, but should bevel somewhat inward in the manner of a bung; the rabbet in the frame being made to answer it. In fixing the frame, it ought to be suffered to lean or batter inward; in which position the door will shut closer, and be less liable to the action of the waves in an exposed situation than it would if it were hung perpendicularly. It ought not, however, to lie so flat or heavy as to prevent the free escape of the internal waters. The floodgates or self-acting sluices, at Bar Loch embankment fall against a flat surface. (fig. 664.)

664



A writer in the *Perth Miscellany* states, (vol. i. p. 41.) that many of the tunnels in the embankments of the Tay have only wooden valves with iron hinges, and a lid of lead or iron nailed on for weight to keep them down. These, he says, are not to be depended on, and he has accordingly had some tunnels made of two inch plank with the end cut at an angle of 45° for the valve, and placed on a slope of 8 inches in 18 feet, the water being discharged on a broad piece of pavement. He had an iron plate "cast the exact size of the mouth of the tunnel, and about half an inch thick, with holes drilled two inches apart, and three-fourths from the edge of the plate, for riveting a piece of saddler's leather, and covered the whole end of the tunnel, the upper end of the leather nailed to the wood serving as hinges, and the edges of the mouth previously lined with the same material. Thus the strength of the tide never raises the valves, and completely prevents the water from getting in." (p. 42.)

or shoemaker's brown sole, which extended at least two inches beyond the plate, and covered the whole end of the tunnel, the upper end of the leather nailed to the wood serving as hinges, and the edges of the mouth previously lined with the same material. Thus the strength of the tide never raises the valves, and completely prevents the water from getting in." (p. 42.)

4335. *The internal waters* which rise within or fall upon the area of the embanked lands, are to be collected by a main drain, continued upward from the floodgate; and furnished with branches to spread over every part of the field of improvement, so as to draw the water from every dip and hollow place as it collects, and thus free the surface effectually from stagnant water; saving such only as may be wanted for the use of pasturing stock.

4336. *If alien waters* have a natural and accustomed channel through the embanked area, it may be found necessary to raise a suitable bank at a proper distance on each side of the stream, in order to prevent its overflowing the area in time of floods. Where it is found that an outlet cannot be had low enough to free the area entirely from surface water, it is requisite (though no alien waters intrude) to form an embanked channel or reservoir, to gain the required outfall; and to throw the waters which lodge on the lower grounds into this receptacle, by a draining mill, of which there are a great variety of constructions.

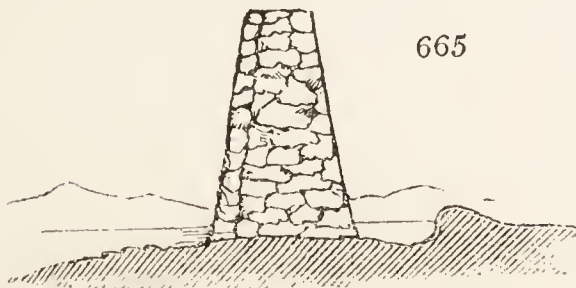
4337. *An embanked channel*, if the banks are raised high enough, or are placed wide enough asunder so as to contain a sufficient body of water, may have a further use, which, in some cases, may be of the highest importance to an improvement of this nature. For, by the help of folding floodgates, such as are commonly seen in use for the locks of navigable canals, placed at the lower end of this canal or reservoir, a body of water may be collected and rapidly discharged; by which easy means, not only the channel of the outer drain, but its mouth, if judiciously contracted, may from time to time be cleared from obstructions. Where alien waters of a good quality pass through the field of improvement, an embanked channel may be profitably applied in watering the lands; and where alien waters, which have not a natural or fortuitous passage through it can be commanded, and conducted to it at a moderate expense, they may prove highly beneficial, for either or both of these purposes.

SUBJECT. 2. *Different Descriptions of Banks in general Use for excluding Waters.*

4338. *Mounds or banks for excluding rivers or the sea* are generally formed of earth, but sometimes also of masonry and even of wood. Embankments of common earth are sufficient for resisting occasional floods: if this earth be loose, the bank will require to be spread out at the base, at the rate of one foot and a half or two feet horizontal for every foot in height; that is to say, a bank of loose earth three feet high will require to be nine feet or twelve feet broad. If the earth to be made use of is a compact clay, or if turf of a solid and compact body can be procured, the slope of the bank may be much steeper, according to its height and the depth of water which may be expected to press against it.

4339. *The earthen wall* (fig. 665.) is the simplest description of embankment, and is frequently erected by temporary occupiers of lands on the general principle of enclosing and subdividing, which is sometimes made a condition of tenure between the landlord and tenant. This wall applies to lands occasionally, but rarely, overflowed or inundated; and is set out in a direction generally parallel to the river or shore. Its base is commenced on the surface, from two to five feet wide, regularly built

665



of turf on the outsides, with the grassy sides underneath. The middle of the wall is filled up with loose earth. The wall is carried up with the sides bevelled towards the

centre, so as to finish in a width of one foot or eighteen inches, at five or six feet in height. Collaterally with such walls, and at the distance of three or four feet, a small open drain is formed, as well to collect the surface water of the grounds within, as that which in time of floods will necessarily ooze through a wall of this construction. The water so collected is let through the wall by tubes, or tunnels of boards, with a valve opening outwards on their exterior extremity. When the flow of water from without approaches, it shuts the valve, which remains in this state till the flood subsides, when, the height of the water within being greater than that without, it presses open the valve and escapes. Walls and valves of this kind are common enough in the drier parts of the fenny districts of Lincolnshire and Cambridgeshire.

4340. *The earthen mound* (fig. 666.) is the most general description of embankment, and, as it is executed at considerable



expense, is only undertaken by such as have a permanent interest in the soil. This barrier applies to sea

lands overflowed by every spring tide, and to alluvial plains inundated by every flood. It is set out in a direction parallel to the shore, and to the general turns of the river, but not to its minute windings; and it is placed farther from or nearer to the latter, according to the quantity of water in time of floods, the rapidity of the current from the declivity of the bed, the straight course of the stream, and the intended height of the bank. The two sides of such a mound are generally formed in different slopes. That towards the land is always the most abrupt, but can never be secure if more so than 45° ; that towards the water varies from 45° to 15° ; the power of the bank to resist the weight of the water, as well as to break its force when in motion, being inversely as its steepness. The power of water to lessen the gravity of bodies, or in other words, to loosen the surfaces over which they flow or stand, is also lessened in a ratio somewhat similar.

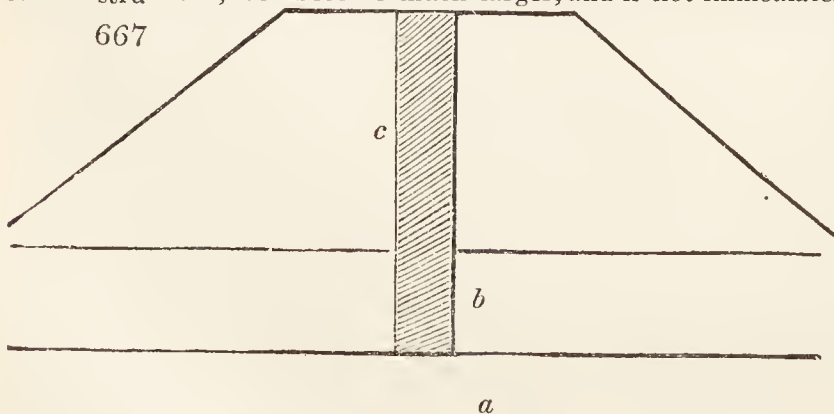
4341. *The formation of the earthen mound* consists merely in taking earth from the general surface of the ground to be protected, or from a collateral excavation, distant at least the width of the mound from its base line, and heaping it up in the desired form. The surface is then in general cases covered with turf, well rolled in order to bind it to the loose earth. The earth of such mounds is generally wheeled in barrows; but sometimes it is led in carts placed on a wooden roller instead of wheels, which, with the treading of the horses, serves in some degree to consolidate the bank.

4342. *The excavation* serves the same purposes as the open drain in the earthen wall; and similarly constructed sluices or valves are introduced on a larger scale. Sometimes, also, the interior water is drawn off by windmills, and thrown over the mound into the river. This is very common in Huntingdonshire, and might be greatly improved on by employing steam engines for entire districts, one of which, of a ten horse power, would do the work of twenty mills, and this in calm weather, when the latter cannot move.

4343. *Embankments of this description are the most universal of any*, and their sections vary from a scalene triangle of ten feet in base, and three feet in height, as on the Forth near Stirling, and the Thames at Fulham, to a base of 100 feet, and a height of ten feet, as in the great bank of the Ouse, near Wisbeach. The great rivers of Germany and Holland are embanked in this way, when so far from the sea as to be out of the reach of the tide; as the Vistula at Marienwerder, the banks of which, near Dantzic, are above fifteen feet in height; the Oder, the Elbe, &c. All these banks are closely covered in every part with a grassy surface, and sometimes ornamented with rows of trees.

4344. *Near the sea, where such banks are washed by every tide* when the course of the wind is towards the shore, and by all land floods and spring-tides, grass is only to be found on and near their summits. The rest of the bank is bare, and to preserve it from the action of waves, currents, and the stones, pieces of wood, and other foreign matters which they carry with them, the surface is covered with gravel, reeds, or straw kept down by pieces of wood; faggots, wicker hurdles, nets of straw ropes, straw ropes laid side by side and fastened, or handfuls of straw fixed in the ground with a dibber (*Neale's Travels in Germany, &c.* chap. i.), or any other contrivance, according to the situation, to prevent the washing away of the bank. It is common to attribute to these coverings the power of breaking the force of the waves; but this power depends, as we have already stated, on the slope of the bank and its smoothness; and the use of the surface covering, and of the constant attention required to remove all obstacles which may be left on it by floods and tides, is to prevent the loosening power of the water from wearing it into holes. For this purpose, a sheet of canvas or straw-netting is as good, whilst it lasts, as a covering of plate iron or stone pavement.

4345. *All banks whatever require to be constantly watched in time of floods or spring-tides*, in order to remove every object, except sand or mud, which may be left by the water. Such objects, put in motion by the water, in a short time wear out large holes. These holes, presenting abrupt points to the stream, act as obstructions, soon become much larger, and if not immediately filled up, turfed over, and the turfs

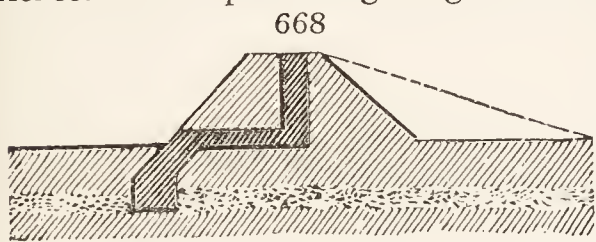


pinned down, or the new turfs rendered by some other means not easily softened and raised up by the water, will end in a breach of the bank. A similar effect is produced by a surface formed of unequal degrees of hardness and durability. The banks of this description in Holland, at Cuxhaven, and along the coast of Lincolnshire, are regularly watched throughout the year; the surface protection is repaired whenever it goes out of repair; as is the body of the bank in the summer season.

4346. *The mound with puddle wall.* (fig. 667.) It generally happens that the earth of

such banks is alluvial, and their foundation of the same description; but there are some

cases where the basis is sand, silt, or gravel; or a mud or black earth, as in some parts of Cambridgeshire and Lincolnshire, which does not easily become so compact. Here it is common, before beginning the bank, to bring up from the solid substratum (*a*) what is called a puddle-ditch, or section of clay in the centre of the highest part of the mound in the direction of its length, and of three or five feet wide, according to the depth of the stratum of silt (*b*), and the intended height of the bank (*c*). When the clay of this puddle-ditch is well worked, either by men's feet or clay rammers, the bank will be perfectly impervious to water, and if against a mild stream or shore, need not contain such an accumulation of earth as where the imperviousness of the bank to water depends chiefly on the mass of materials. As already observed, the important point to attend to in this variety of mound is, to found the section, or wall of clay, so deeply as to be in contact with a stratum (*a*), either by induration, or its argillaceous nature, impervious to water. In the drainage of the Bar Loch in the county of Renfrew, considerable difficulty was experienced in some places in getting to the bottom of the sandy subsoil, so as to bring up the



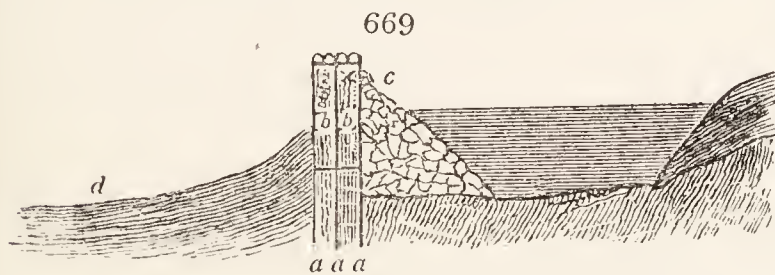
puddle wall from the retentive stratum. Such was the difficulty in some cases, that the puddle could not be carried up perpendicularly, but a puddle wall being raised within the bank, as high as the natural surface, it was joined horizontally to another puddle wall in the body of the bank. (*fig.* 668.)

4347. *Puddling* is often found defective, owing to the imperfect working of the materials. Many think that when clay is used, if it be worked into the consistence of dough, it is sufficient; but this is a mistake: it should be slaked and so decomposed by the labour of proper tools and treading, and so completely saturated with water, that the whole mass becomes one uniform and homogeneous body, and almost fluid.

4348. *Mounds with reversed slopes.* In some cases of embanking rivers, as where they pass through parks, it is desirable to conceal, as much as possible, the appearance of a bank from the protected grounds. Hence the mound is simply reversed, the steepest side being placed next the water. It is proper to observe, that such banks are not so strong, by the difference of the weight of the triangle of water which would rest on the prolonged slope, were it placed next the river, and are more liable to be deranged in surface in proportion to the difference of the slopes, the water acting for a longer period on every part of the slope.

4349. *Mound faced with stones.* This is the same species of mound, with a slope next the water of forty-five or fifty degrees, paved or causewayed with stones or timber. In Holland this pavement or causeway is often formed of planking or bricks; but in England generally with stones, and the mortar used is either some cement which will set under water, or, what is better, plants of moss firmly rammed between them. The objections to such banks are their expense, and their liability to be undermined invisibly by the admission of the water through crevices, &c. They are, therefore, chiefly used where there is little room, or where it is desirable to narrow and deepen the course of a river.

4350. *The bank formed with piles, brushwood, and stones,* is occasionally used for protecting moving sands, or directing the course of streams flowing through a sandy shore. A dike or bank for the latter purpose (*fig.* 669.) has been erected on the river Don in Aberdeenshire.

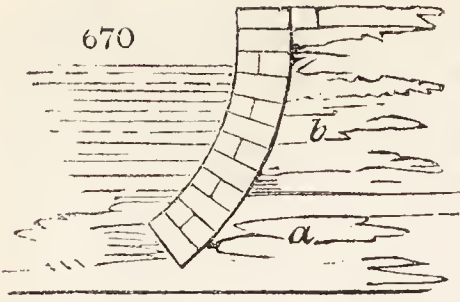


It consists of piles or poles, being the thinnings of plantation of Scotch pine and larch, driven six feet into the sand (*a a a*): the spaces between these piles (*b b*) are filled in with furze or other spray or small branches; and on the top of them, are wedged in stones to

keep them down. On the side of this row of piles next the river, stones (*c*) from 50lbs. to half a ton weight each, are precipitated from a punt, until they form a bank of an angle of nearly 45°. On the outside of this bank and piles, the sand (*d*) gradually drifts up, and forms a bank, which, being planted with *Arundo arenaria* and other grasses, gradually becomes covered with verdure. (*Highland Soc. Trans.* vol. vii. p. 91.)

4351. *Mound protected by a wicker hedge.* This is a Dutch practice, and, where appearance is no object, has the advantage of not requiring watching. Wicker-work, however, subjected to the strain of waves, will be obviously less durable, than where it lies flat on the ground, and can only decay chemically. This wicker hedge is sometimes a series of hurdles supported by posts and studs; but generally in Britain it is a dead hedge or row of stakes, wattled or wrought with bushes presenting their spray to the sea or river. Besides placing such a hedge before a bank, others are sometimes placed in parallel rows on its surface; the object of which is to entrap sand, shells, and sea weeds, to increase the mass of mound, or to collect shells for the purpose of carrying away as manure.

4352. *The sea wall* (fig. 670.) is an embankment formed to protect abrupt and earthy shores or banks of rivers, and consists of a wall, varying in thickness, and in the inclination of its surface, according to the required height, and other circumstances. Belidor, in his *Traité de Hydraulique*, has given the exact curve which the section of such a wall ought to have (*a, b*), in order to resist loose earth, and which is somewhat greater than where the earth behind the wall is supposed to be chiefly firm. Some fine examples of such walls, for other purposes, occur in the



Caledonian Canal; and perhaps the finest in the world are the granite walls which embank the Neva at Petersburg, the construction of which may serve as an example of a river cased with stone on a foundation of soft bog earth.

4353. *Embankments for fixing drifting-sands, shells, or mud.* In several tracts of coast, the sea at ordinary tides barely covers a surface of sand; and these sands, in dry weather, during high winds, are drifted and blown about in all directions. Great part of the north shores of the Solway Frith, of Lancaster Bay, and of the coast of Norfolk, is of this description. Young, in his *Farmer's Letters*, informs us, that a considerable part of the county of Norfolk was drift sand, and even as far inland as Brandon in Suffolk, before the introduction of the turnip culture; and Harte (Essay I.) states that some of what is now the richest land in Holland, was, about the middle of the sixteenth century, of this description. The suggestion of any mode, therefore, by which, at a moderate expense, such tracts could be fixed, and covered with vegetation, must be deemed worthy of notice. The mode which nature herself employs is as follows: After the tides and wind have raised a marginal steep of land as high as high water-mark, it becomes by degrees covered with vegetation, and chiefly by the *Elymus arenarius*, *Triticum junceum*, various species of *Juncus*, and sometimes by the *Galium verum*. With the exception of the first of these plants (the leaves and stalks of which are manufactured into mats and ropes in Anglesea, and the grain of which is sometimes ground and used as meal in Ireland), they are of no other use than for fixing the sands, which, being composed in great part of the débris of shells, expand as they decay, and contribute to raising the surface still higher, when the fibrous roots of good grasses soon destroy the others. The *Arundo arenaria* is planted in Holland for the purpose of binding sands, and was extensively introduced into the Highlands of Scotland for the same purpose, by Macleod of Harris, in 1819. (*Trans. Highl. Soc.* vol. vi. p. 265.)

4354. *To assist nature in fixing drift-sands*, it is only necessary to transplant the *Elymus*, which is to be had in abundance on almost every sandy coast in Britain; and as it would be liable to be blown away with the sands, if merely inserted in the common way, it seems advisable to tie the plants to the upper ends of willow or elder rods, of two or three feet in length, and to insert these in the sand, by which means there is the double chance of the grass growing, and the truncheon taking root. The elder will grow exposed to the sea breeze, and no plant throws out so many and such vigorous roots in proportion to its shoots.

4355. *The mode by which such sands were fixed in Holland* was by the formation of wicker-work embankments, and by sticking in the sands branches of trees, bushes, furze, &c. in all directions. These obstructed the motion of the sands, and collected masses of sand, shells, or mud, and sea-weeds around them, which were immediately planted with some description of creeping grass; or, what was more frequent, covered with a thin coating of clay, or alluvial earth, and sown with clover. Though the most certain and least expensive mode of gaining such lands is undoubtedly that of seconding the efforts of nature, by inserting bushes and planting the *Elymus* in this way; yet it may sometimes be desirable to make a grand effort to protect an extensive surface, by forming a bank of branches, which might, in a single or several tides, be filled with sand and shells. It is evident, that such a bank might be constructed in various ways; but that which would be most certain of remaining firm, and effecting the purpose, would be one regularly constructed of framed timber, the section of which would resemble a trussed roof; each truss being joined in the direction of the bank by rafters, and the whole inside and surface stuck full of branches. To retain it firm, piles would require to be driven into the sand, to the upper parts of which would be attached the trusses. The height of such a barrier would require to be several feet above that of the highest spring-tides; and the more its width at base exceeded the proportion of that of an equilateral triangle the better.

4356. *A mode suited to a less extensive scale of operation*, is to intersect a sandy shore in all directions, with common dead or wicker-work hedges, formed by first driving a row of stakes six or eight feet into the ground, leaving their tops three or four feet above it, and then weaving among these stakes, branches of trees, or the tops of hedges. The Dutch are said to weave straw ropes in this way, and thereby to collect mud in the manner of *warping*. This mode, being little expensive, seems to deserve a trial in favourable situations; and in so doing, it must not be forgotten, that much depends on the immediate management of the surface, after it is in some degree fixed. In an extensive trial of this sort at present in progress on the west coast of Scotland, under an English gentleman, seeds and roots are baked in a mixture of loam, dung, and gravel, and then formed into masses, and scattered over a sandy surface. These, from their weight, will not, it is thought, be moved by the water or the wind; but, becoming more or less covered with sand, the mass will be kept moist, and the seeds and roots will grow, and, fixing themselves in the soil, will in time cover the surface with verdure. The experiment is ingenious, and we hope will be crowned with success.

4357. *Embankments of cast iron* have been proposed to be constructed by Deeble, a civil engineer of London. He proposes to combine a series of caissons, made of cast iron, in ranges, agreeable to the required form of the intended embankment. The caissons are to be fastened together by dovetails, and, being hollow, are, when fixed in their intended situations, to be filled with stones and other materials, making them up solid. (*Newton's Journal*, vol. ii. p. 202.)

SUBCT. II. *Guarding the Banks and otherwise improving the Courses of Rivers and Streams.*

4358. The subject of *guarding the banks of rivers* is of considerable interest to the proprietors of lands situated in hilly districts, where, in the valleys and on the hill sides, the streams often produce ravages on the banks, and sometimes change their courses.

4359. The natural *licence of rivers*, Marshal observes, is not only destructive of landed property, frequently of lands of the first quality; but is often the cause of disputes, and not unfrequently of legal contentions, between neighbouring proprietors. A river is the most unfortunate boundary line of an estate. Even as a fence, unless where the water is unfordable, a river, or rapid brook, which is liable to high floods, is the most tormenting and inefficient. Proprietors have therefore a double interest in accommodating each other, as circumstances may require, with the lands of river banks, so as to be able to fix permanent boundary lines between their properties. When the owners of estates cannot, by reason of entails or settlements, or will not for less cogent reasons accommodate each other, they have a line to tread which they cannot deviate from with prudence, much less with rectitude; namely, that of cautiously guarding their own lands, without injuring those of their neighbours; for a lawsuit may cost ten times the value of the sand banks and islets of gravel to be gained by dexterity of management.

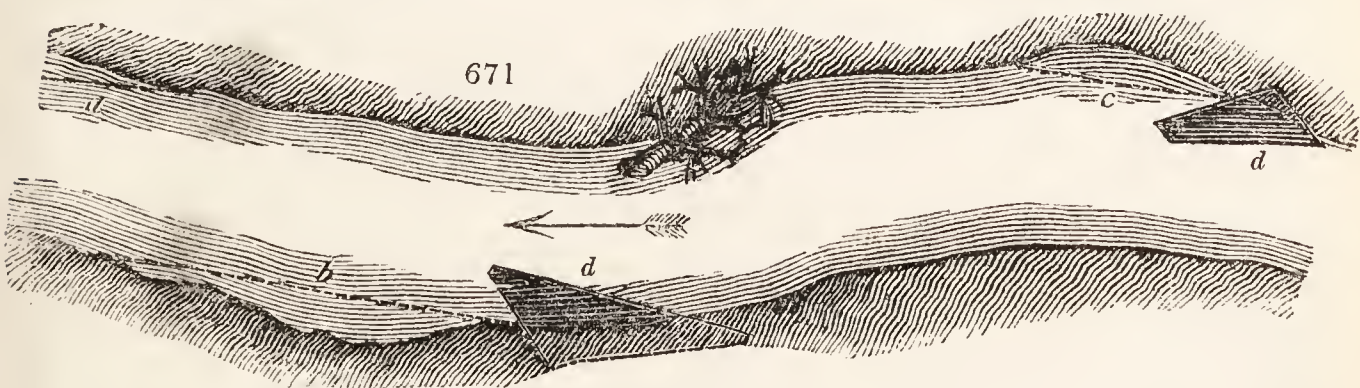
4360. *The operations for improving rivers* have for their object that of preventing them from injuring their banks, of accelerating their motion, and of lessening the space of ground which they occupy, or altering their site. These purposes are effected by piers or guerdes for altering the direction of the current; works for protecting the banks; and by changing or deepening the river's course.

4361. *The principles on which these operations are founded* are chiefly two; first, that water, like every other body when it impinges on any surface, is reflected from it at a similar angle to that at which it approached it; and, secondly, that the current of water, other circumstances alike, is as the slope of the surface on which it runs. On the first of these principles is founded the application of piers for reflecting currents; and on the second, that of straightening rivers, by which more slope is obtained in a given length of stream, and of course greater rapidity of motion obtained.

SUBJECT. 1. *Guarding River Banks.*

4362. *A common cause of injury to the banks of rivers* is produced during floods. A tree or branch carried down by a stream, and deposited, or accidentally fixed or retained, in its banks, will repel that part of the stream which strikes against it, and the impulse (counteracted more or less by the general current) will direct a substream against the opposite bank. The effect of this continual action against one point of the opposite bank is, to wear out a hole or breach; and immediately above this breach it is customary to place a protecting pier to receive the impulse of the substream, and reverberate it to the middle of the general stream. But if this pier is not placed very obliquely to the substream, as well as to the general stream, it will prove injurious to the opposite bank by directing a subcurrent there as great as the first; and, indeed, it is next to impossible to avoid this; so much so, that Smeaton, in almost every instance in which he was consulted in cases of this sort, recommended removing the obstacle where that could be done, and then throwing loose stones into the breach.

4363. *Injuries by floods*, according to Marshal, are to be remedied in two ways; the one is to sheath the injured banks of the bays (*fig. 671. a, b, c*) with such materials

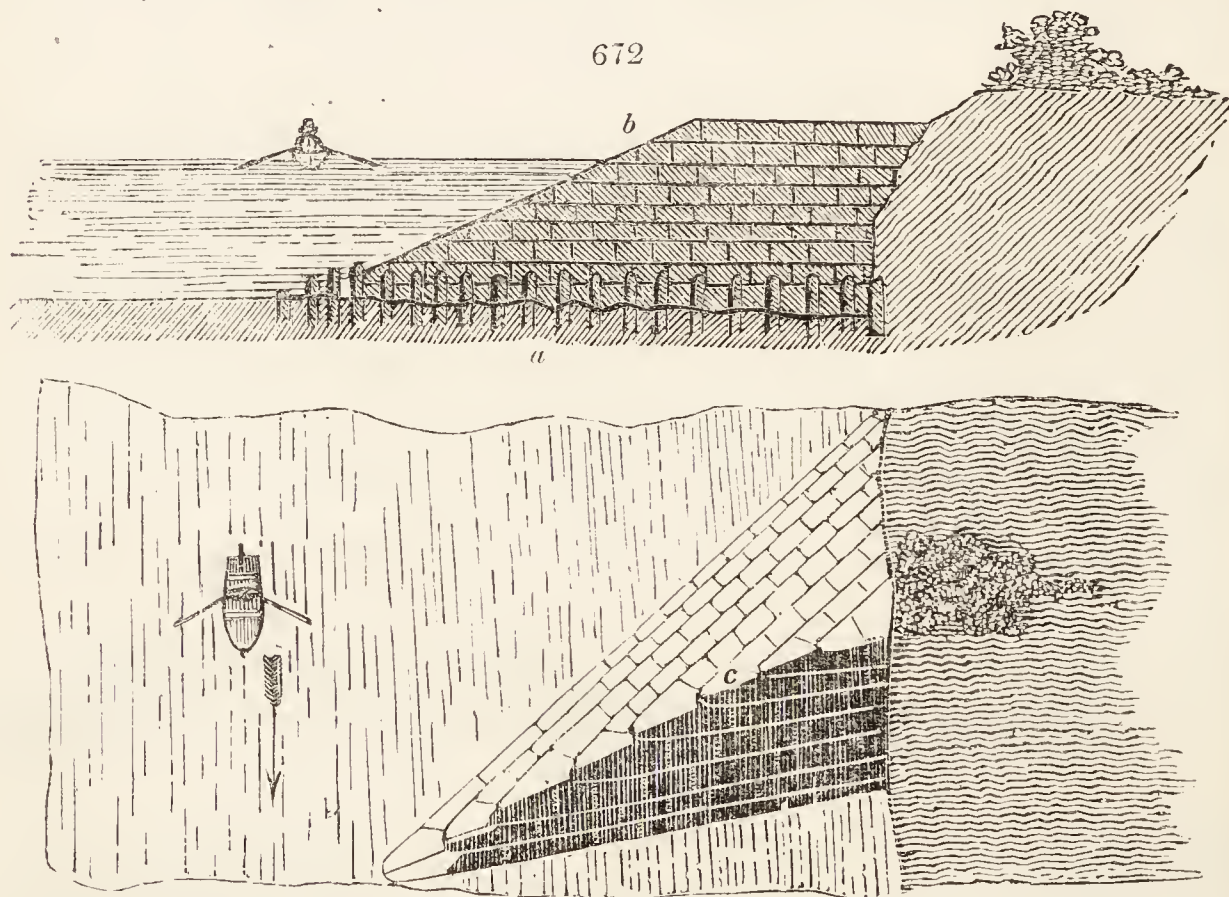


as will resist the circuitous current; and let the river remain in its crooked state. The other, to erect piers (*d*), to parry off the force of the current from the bank, and direct it forward; with the twofold intention of preventing further mischief, and of bringing back the course of the river to its former state of straightness. It is to be observed, that the operation of guarding the immediate bank of a sharp river bend, against a heavy current meeting with great resistance, by sheathing it with stones, is generally a work of much

difficulty and expense, even where materials can be easily procured : while that of diverting the current by a pier may frequently be accomplished at a comparatively small cost ; and its effect be rendered infinitely more salutary and permanent. For it is plain that, if the accidental obstruction mentioned had been timely removed, no bad effect would have ensued : and the river would have continued its direct course. Or if, through neglect, it had been suffered to remain awhile, until its mischief was discoverable ; even then, if it had been moved from its station to the opposite side of the river, and placed in the part affected, this small counterpoise might have recovered the balance of the current, and directed it into its wonted channel ; and, in almost any case, by judiciously placing, in a similar manner, a pier or other obstruction proportioned to the magnitude of the power to be counteracted, the like effect may be produced.

4364. *In the use of piers great caution is requisite*, for a very little reflection will show that they are more likely to increase than to remedy the evil they are intended to cure. We have seen the injurious effects of such piers on the Tay and the Dee ; and on a part of the Jed near Crailing they are so numerous, that the stream is, to use a familiar phrase, bandied about like a foot-ball, from one shore to the other ; behind every pier an eddy is formed, and if the stream does not strike the pier exactly, a breach in the bank takes place. Many of these piers have, in consequence, been taken down. The use of such piers can only be justified where the obstruction, from ill-neighbourhood or some such cause, cannot be removed from the opposite bank ; or where, as is sometimes the case, it arises from an island of sand or gravel thrown out by the river near its middle, which, however absurd it may appear, the interested parties cannot agree as to who may remove. The case of buildings also being in danger may justify such a pier for immediate protection ; but if such breaches are taken in time, a few loads of loose stones dropped in the breach, as recommended by Smeaton, will effect a remedy without the risk of incurring or occasioning a greater evil.

4365. *In the construction of piers*, attention is required to secure the foundation, either by first throwing in a quantity of loose stones, which the water will in a great measure dispose of so as to form a flat surface ; or by the use of piles either under, or in single or double rows around, those parts of its base in contact with the river. (*fig. 672. a.*) The elevation (*b*), where the current is not required to act with great violence on the opposite shore, ought to be bevelled back on all sides exposed to the water, towards the middle of the structure (*c*). In the most important cases stones are the only fit materials, and these



should be regularly jointed and laid in cement according to the best practice of masonry. But, in general, a case of wicker work, of the proper shape, may be filled in with loose stones, some earth, together with the roots of such plants as *Tussilago Petasites*, *Elymus arenarius*, *Galium*, &c. These will form a barrier of considerable durability for some years, and probably till the evil is so far subdued that, when the wicker case decays, its contents will have sufficiently consolidated to effect the object without further care. If not, the wicker case may be renewed. In ordinary cases, a mere wicker hedge projecting into the water will effect the object without further trouble.

4366. *The sheath, or land-guard of loose stones*, which Marshal recommends, and which, in effect, is the mode already mentioned (4362.) as preferred by Smeaton, is applicable to the following cases : — First, where the river, in the part required to be bent, is confined, by rocks or otherwise, to an unalterable channel, as it frequently is in subalpine situations ; and, secondly, where a deep pool occurs in that part, at low

water, so as to render it difficult to get a proper foundation for a pier. Where the foot of the injured bank is covered with a pool at low water, shelve off the brink of the bank, and shoot down loose stones from the top of it; suffering them to form their own slope, in the action of falling, and by the operation of succeeding floods: continuing to pour them down, until the bank be secured, at least from minor floods, and then slope back the upper part, to give freedom to floods of greater magnitude.

4367. *When the channel of a rapid river is narrow, and the banks undermined and washed away by the torrents, what Marshal terms the land-guard is to be used.*

4368. *In forming a land-guard for this purpose, he says, the foundation should be laid pretty deep, to guard against any accidental scoopings from the floods. The wall ought to be carried up dry, or without mortar, the stones being laid with their ends outward, their inner ends pointing to the same centre, like those of an arch, and to be backed with gravel, or earth, rammed in firmly behind, as the facing is carried up. The coping or uppermost course of the stones is to be securely bound, with thick tough sods (8 or 10 inches deep), whose surfaces, when beaten down, ought to lie even with that of the stonework; and similar sods require to be laid, with a gently rising slope, until they unite smoothly with the natural turf of the land to be defended; so that the waters of floods, when they rise above the stonework, may have no abruptness to lay hold of, but may pass away smoothly over the surface of the land, as they commonly do over smooth greensward, without injury. Finally, the stones are to be beaten forcibly into the bank, with a rammer, a mallet, or a small battering-ram, adapted to the purpose; thus rendering the whole compact and firm, to resist the current. Where vacancies or fissures still appear, long splinters of stone are to be driven in, as wedges, to increase the firmness, and prevent the current from tearing out an unguarded stone. It follows, of course, that the largest and longest of the stones ought to be used where the greatest resistance is known to be required.*

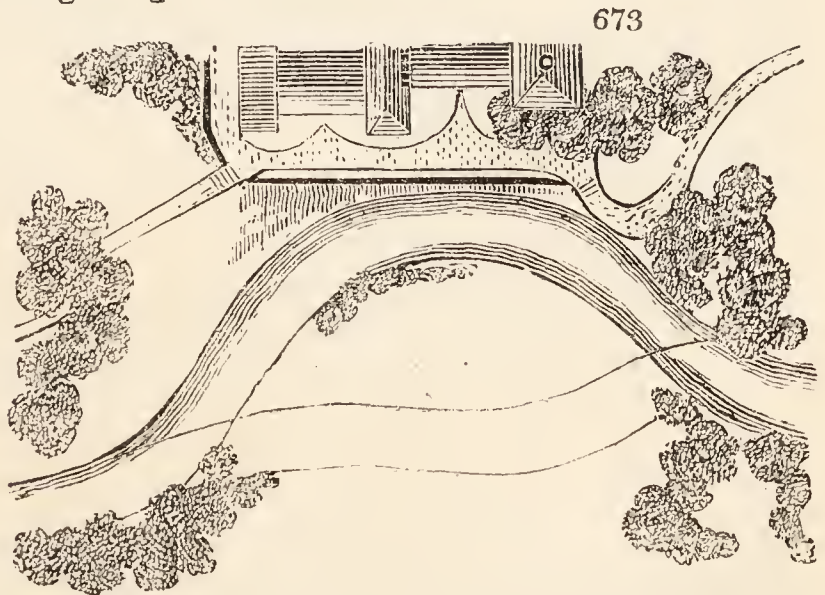
4369. *The repairs of a bulwark of this sort, like every other species of river fence, require to be attended to from time to time, especially after great floods. If the foundation be laid bare, it requires to be re-covered with rough gravel, or with stones thrown loosely against it. If any of the facing stones be displaced or loosened, they are to be wedged in afresh, or their place supplied by others. Or, if the turf which binds them at the top be disturbed, the torn part should be cut out square, and be firmly and completely filled up with fresh turves.*

SUBSECT. 2. *Changing the Courses of Rivers, deepening their Beds, or raising their Waters to a higher Level.*

4370. *A river whose course is in a straight line, or nearly so, hardly ever makes any encroachment on its banks, except perhaps very large rivers, when they rise above their usual level, either by an increase in their own waters, or from their flow being in some degree interrupted by the tides. Hence, whenever a river is narrow in its channel and winds considerably, any mischief it commonly occasions may be prevented by deepening and straightening the course of the stream. (Code of Agr. p. 319.)*

4371. *The alteration of the course of a river or brook is attended with difficulty and expense, according to the particular circumstances. In a simple case, in which one straight cut only is required, the principal difficulty, and that which requires the best skill of the artist, lies in directing the current of the first flood, out of the old into the new channel: but if a bend of the old channel can be made use of, this difficulty may be said to vanish. The mouth of the new cut receives the current with a straight course; consequently, if it be made of sufficient capacity, the river, in a flood, can have no propensity left towards its old channel: and the loose materials which rise in forming the mouth of the new cut, will generally be sufficient to turn the stream at low water into it. But if a suitable bend cannot be approached by the new cut, a directing pier will be required to bend the flood current, and give it a straightforward course into the new channel: a watertight dam being formed between the point of the pier and the firm bank of the new channel to prevent the water from regaining its wonted course.*

4372. *An entirely new bed or channel, however, is much to be preferred where it can be obtained: for in an altered course, when the stream passes alternately through new soil and through a part of its old bed, its action on surfaces which are so different in regard to induration ends, if great care is not taken, in holes and gulleys in the new bank, which require to be constantly filled up with loose stones thrown in, and left to be fixed by the pressure and motion of the water. In the case of a river passing near a house (fig. 673.) this is sometimes of great importance.*



4373. *Cutting the new channel is merely a work of manual labour; being attended with no other difficulty than what may arise from the expense, which will depend on the size of the river, the nature of the ground to be cut through, and the value of labour in the given district. It is mostly to be ascertained with sufficient accuracy by previous calculations. (See 3323.)*

4374. *The size of the new cut, on account of its greater depth, may be small, compared with that of the*

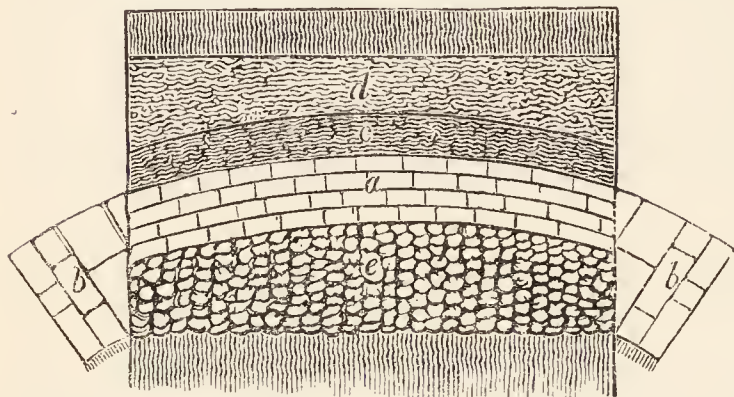
old channel. For the current of floods, by carrying off the earthy particles with which they come in contact, will soon enlarge it. It is nevertheless right to give ample room in the new channel, lest the first flood should prove high, and, by bursting its bounds, force its way back to its former course.

4375. *A new river course* requires to be carefully attended to, during a few years after it is opened, to see that its channel preserves its straightness, and that no breaches are made or threatened in its banks. Considering the uncertainty of extraordinary floods, it cannot be said to be out of danger in less than three years: hence it becomes prudent, when a work of this nature is contracted for, or undertaken to be done by measurement at an estimated price or prices previously agreed upon (as it generally ought), that the undertaker should agree to preserve the straightness of the channel, and uphold its banks during that or some other time fixed upon; and to deliver them up, at the end of the term, in the state and condition specified in the contract.

4376. *A case of straightening the course of a river* is given in *The Code of Agriculture*. The waters, which in their crooked course were formerly almost stagnated, now run at the ordinary rate of the declivity given them. They never overflow their banks. Cattle can now pasture upon those grounds in which they would formerly have been swamped. The surface of the water being now in general four, and sometimes six feet below that of the adjacent fields, this cut serves as a general drain to the whole valley; so that three hundred acres of meadow may be converted into arable land; sixty acres of moss may be improved into meadow; and five hundred acres of arable land are rendered of double their former value. (p. 319.)

4377. *Raising rivers to a higher level.* As rivers and streams may require to be

674



deepened for the purpose of drainage, so may their waters require to be raised for the purpose of irrigation, impelling machinery, or producing cascades or waterfalls for the purpose of ornament. Dams or weirs for this purpose should be constructed so as to form a segment of a circle across the bed of the stream, with the convex side pointing up the stream, and the ends abutting against a natural or artificial bank (*fig. 674.*) By this construction, the force of the

water, however great, will be effectually resisted, and the structure remains secure. The

greater the slope towards the upper side, the better, but the lower side should be nearly

perpendicular, that the water may fall over it without coming in contact with the face

of the building. (*fig. 675.*)

The wall (a) should be

built of regularly hewn stone, as should the abut-

ments (b); next the wall

there should be a mass of clay as a puddle (c), and

above that gravel or earthy

matter of any kind to a considerable slope (d). Beneath the dam a considerable por-

tion ought to be paved (e). (*Gen. Rep. Scot. vol. ii. p. 669.*)

4378. *Heads, or banks of earth*, for the confinement of water in artificial lakes or

ponds, are often constructed at great expense, and, not being properly formed, often break

out, and occasion considerable damage. The error in their construction is commonly

owing to the want of breadth at the base in proportion to their height, and their not

having a sufficient slope towards the water, nor a proper section of puddle in the

centre. (*Ibid.*)

4379. *Heads of loose stones of a large size* (*fig. 676.*) may be had recourse to in slow

running rivers not subject to high floods, and where there is

such a superabundance of water that no loss is sustained by the

quantity which flows through the stones. Where it is re-

quired to retain the whole of

the water, a puddle bank should be carried up the middle of the dam. (*Ibid.*)

SECT. I. *Irrigation, or the Preparation of the Surface of Lands for the profitable Application of Water.*

4381. *Irrigation* in its different forms may be considered an operation of culture as well as of permanent improvement. It is accordingly in many cases effected by tenants, but always, as in the case of improving wastes, in consequence of extraordinary encouragement from the landlord, by long leases, money advanced, or other advantages.

4382. *The application of water to the surface of lands* for the purpose of promoting vegetation has been practised, as we have seen (141.), from the earliest ages in warm countries. Solomon made him gardens, and orchards, and pools of water to water therewith the wood that bringeth forth the trees. (*Ecclesiastes.*) The art was taught by nature in the overflowing of the Nile and other rivers. Water is an essential article for the culture both of the cereal and pasture grasses, and indeed of most herbaceous crops, in all the tropical climates, and even in a great degree in the South of Europe. In the greater part of Italy and Spain, few crops are raised without being irrigated; and even in the south of France, potatoes, maize, madder, and sometimes vines, and orange trees, (as at Hieres,) have water applied to their roots, by furrows and other gutters and trenches formed on the surface. The system of watering grass lands was revived in Italy in the ninth century, and seems to have been practised in a few places in Britain from the time of the Romans; there being meadows near Salisbury which have been irrigated from time immemorial. In 1610, the public attention was called to it by Rowland Vaughan, in a work entitled, "Most improved and long experienced Water Works; containing the manner of summer and winter drowing of meadow and pasture, by the advantage of the least river, brook, fount, or water mill adjacent; thereby to make those grounds (especially if they be dry) more fertile ten for one."

4383. *Irrigation in former times*, and in all countries, however imperfect, was probably much more frequent than it is now. In light and gravelly tracts of country, the greatest difficulty in farming was to procure a sufficient supply of fodder for their cattle in winter. Meadows were therefore indispensable, and to increase the crop of hay, watering in a dry spring, and immediately (in dry summers) after the first crop was off, was constantly followed. Since the practice of sowing artificial grasses, and the introduction of the turnip husbandry, the custom of watering has been in such situations given up; not only because it has become less necessary than it was heretofore, but because *watered* meadow hay is of inferior quality as well as value in the market. It is nevertheless true that the herbage of very coarse boggy meadows is improved, and that of cold meagre soils is accelerated and increased by it.

4384. *But the principal scientific efforts in watering lands* have been made during the latter end of the last and beginning of the present century, in consequence of a treatise on the subject by George Boswell, published in 1780, and various others by the Rev. Thomas Wright, of Auld, in Northamptonshire, which appeared from 1789 to 1810. The practice, however, has been chiefly confined to England, there being a sort of national prejudice, as Loch has observed (*Improvements on the Stafford Estates, &c.*), against the practice in Scotland, though its beneficial effects may be seen as far north as Sutherland, where rills on the sides of brown heathy mountains never fail to destroy the heath plants within their reach, and these are succeeded by a verdant surface of grasses. A valuable treatise on the subject of irrigation in Scotland, by Dr. Singer, will be found in *The General Report of Scotland*, vol. ii. p. 610. In England the best examples of watering are to be found in Gloucestershire and Wiltshire. In our view of this subject, we shall first consider the soils and situations suitable for irrigation, and next the different modes of effecting it, known as flooding, irrigating, warping, irrigation on arable lands, and subterraneous irrigation.

SUBSECT. 1. *Soils and Situations suitable for Watering.*

4385. *The theory of the operation of water on lands* we have already developed. It appears to act as a medium of conveying food, as a stimulus, as a consolidater of mossy soils, as a destroyer of some descriptions of weeds or useless plants, and as the cause of warmth at one season, and of a refreshing coolness at another. From these circumstances, and also from what we observe in nature, there appears to be no soil or situation, nor any climate, in which watering grass-lands may not be of service; since the banks of streams between mountains of every description of rock, and in every temperature from that of Lapland to the equator, are found to produce the richest grass. One circumstance alone seems common to all situations, which is, that the lands must be drained either naturally or by art. The flat surfaces on every brook or river, after being covered with water during floods, are speedily dried when they subside, by the retiring of the waters to their channel.

4386. *The most proper soils for being watered* are all those which are of a sandy or gravelly friable nature, as the improvement is not only immediate, but the effects more

powerful than on other descriptions of land. There are also some strong adhesive sour wet lands, such as are common in the vicinity of large rivers, which are also capable of being improved by watering; but the beneficial effects are not in such cases so soon produced as on the first sorts, nor is the process so advantageous to the farmer, on account of the very great expense to which he must, in many cases, be put by previous draining. There are some other lands, as those which contain coarse vegetable productions, as heath, ling, rushes, &c. which may likewise be much improved by watering. It must be kept constantly in mind, in attempting this sort of improvement, that, the more tenacious the soil is, the greater should be the command of water for effecting the purpose; as a stream, capable of watering fifteen or twenty acres of light dry land, would be found to be beneficial in but a small degree when applied to watering half the same quantity of cold clayey ground such as in its natural state abounds with coarse plants. On all soils of the latter kind a considerable body of water for the purpose of floating them is required to produce much benefit, and where a sufficient quantity cannot be procured, this mode of improvement will seldom answer the farmer's intention or be advantageous in the result.

4387. *Smith, an experienced irrigator*, supposes that "there are only a few soils to which irrigation may not be advantageously applied: his experience, he says, has determined, that the wettest land may be greatly improved by it, and also that it is equally beneficial to that which is dry." (*Obs. on Irrigation, &c.*) But, as many persons unacquainted with the nature of irrigation may be more inclined to the latter supposition than the former, he explains the reason of wet land being as capable of improvement from flooding as that which is completely dry. It is, that, in the construction of all water meadows, particular care must be taken to render them perfectly dry when the business of floating shall terminate; and that the season for floating is in the winter and not in the summer, which those who are unacquainted with the process have too generally supposed. All peat bogs are certainly of vegetable origin, and those vegetables are all aquatic. It follows that the same water which has produced the vegetables of the bog would, under due management upon the surface, produce such grasses, or other vegetables, as are usually grown by the farmer; and he has hitherto had reason to think that this may be considered as a general rule for determining the situation of any experiments with water. The lands that permit of this sort of improvement with the most success are such as lie in low situations on the borders of brooks, streams, or rivers, or in sloping directions on the sides of hills.

4388. *The purity of the water to be used in irrigation* is supposed by some to be a matter of the first importance; but it is now fully proved, by the accurate experiments of an able chemist, and by the extraordinary growth of grasses in *Pristley meadow*, in *Bedfordshire*, that ferruginous waters are friendly to vegetation, when properly applied. (*Smith's Observations on Irrigation*, p. 28.) Lead or copper never does good, and it is well known, that waters of that description, after they have been brought into fields, by levels cut at a considerable expense, have again been diverted, and suffered to flow in their original channels. Waters impregnated with the juices that flow from peat-mosses, are considered by many not worth applying to the soil. It is objected to them, that they are soon frozen, that they convey no material nutriment, and that they are commonly loaded with such antiseptic substances as, instead of promoting, will retard vegetation. (*Dr. Singer's Treatise*, p. 579.) It is urged, on the other hand, that a want of sufficient slope in the meadow, or of proper management in regard to the water, may have occasioned the disappointments experienced in some cases, when bog-waters have been applied. (*Derbyshire Report*, vol. ii. p. 463.)

4389. *The advantages of watering lands* must, in a material degree, depend on the climate. It is evident that the benefit to be derived from this process in *Sweden*, for example, where the summers are short, must be greatly inferior to what it is in *Lombardy*, where grass grows all the year; and that in *Perthshire*, where grass ceases to grow for at least three and often four months in the year, it must be much less than in *Gloucestershire* or *Ireland*, where its growth is not interrupted above a month or six weeks, and sometimes not at all: most grasses vegetating in a temperature of 33 or 34 degrees. Still, however, as the most luxuriant pastures are found on lands naturally watered, both in *Sweden* and *Perthshire*, it would appear worth while to imitate nature in cold as well as in warm countries. According to many writers on the subject, the benefits attending watering in *England* are immense. In *Davis's Survey of Wiltshire*, it is calculated that 2000 acres of water meadow will, on a moderate estimate, produce, in four or five years, 10,000 tons of manure, and will keep in permanent fertility 400 acres per annum of arable land.

4390. *Watering poor land*, especially if of a gravelly nature, is stated in *The Code of Agriculture* to be by far the easiest, cheapest, and most certain mode of improving it. "Land, when once improved by irrigation, is put in a state of perpetual fertility, without any occasion for manure, or trouble of weeding, or any other material expense. It becomes so productive, as to yield the largest bulk of hay, besides abundance of the very best support for ewes and lambs in the spring, and for cows and other cattle in the autumn of every year. In favourable situations, it produces very early grass in the spring, when it is doubly valuable; and not only is the land thus rendered fertile, without having any occasion for manure, but it produces food for animals, which is converted into manure, to be used on other lands, thus augmenting, in a compound proportion, that great source of fertility." Were these advantages more generally known, or more fully appreciated, a large proportion of the kingdom might become like *South Cerney*, in *Gloucestershire*, where every spring, or rivulet, however insignificant, is made subservient to the purpose of irrigation, fertilising, in proportion to its size, either a small quantity or a large tract of land. (*Gloucestershire Report*, p. 280.)

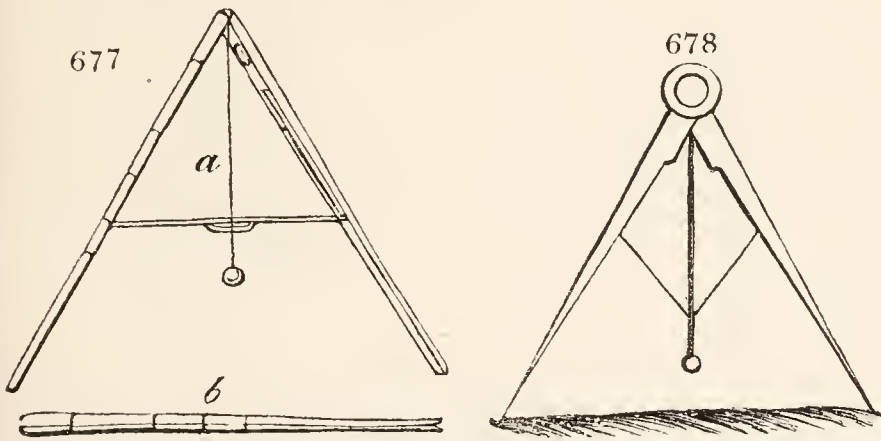
4391. *Irrigation by liquid manure* may occasionally be practised in the neighbourhood of towns and cities to the greatest advantage. In the neighbourhood of *Edinburgh*, we

are informed by Stephens, upwards of 200 acres are so irrigated from the principal common sewer, and that, although the formation of these meadows is irregular, and the management very imperfect, the effects of the water are astonishing: they produce crops of grass not to be equalled, being cut from four to six times a year, and the grass given green to milch cows.

SUBJECT. 2. *Implements made Use of in Watering Lands; and the Terms of Art peculiar to such Operations.*

4392. *The principal instruments made use of in the preparation of lands for watering are the following:—*

4393. *The level, of which different descriptions have already been given, is necessarily employed to take the level of the land at a distance, compared with the part of the river, &c. whence it is intended to bring the water, to know whether it can or cannot be made to float the part intended to be watered. Bringing the water after them to work by is found very useful in undertakings of this nature, especially when on a large scale, though the workmen too frequently dispense*



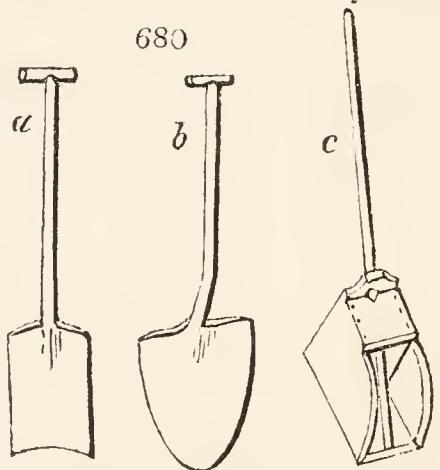
with it. In drawing a main, they begin at the head, and work deep enough to have the water to follow them; and in drawing a tail drain, they begin at the lower end of it, and work upwards, to let the water come after them. The level should, however, be made use of, as being more certain and correct. Brown, an experienced irrigator in the west of England, recommends a level (fig. 677. a), which when not in use may be closed (b) like a walking-stick. There is also a compass level (fig. 678.), which may be used in the same way.

4394. *A line and reel, and a breast-plough, or turf spade (fig. 211.), are likewise absolutely necessary. The use of the two former are well known; but as the line is mostly used in the wet, it should for this purpose be larger and stronger than those employed in gardening. The turf spade should be of the best description, being principally employed in cutting turfs for the sides of the channels.*

4395. *The spades made use of in this sort of work (fig. 679.) should have the stems considerably more crooked than those of any other kind; the bit being of iron, about a foot wide in the middle, terminating in a point; a thick ridge running perpendicularly down the middle, from the stem almost to the point; the edges on both sides should be drawn very thin, and as they are obliged to be kept very sharp, they should be often ground and whetted. This necessarily wears them away, and they soon become narrow; they are then used for the narrow trenches and drains, whilst new ones are used for the wider. From the stems being made crooked, the workmen, standing in the working position in the bottom of the trench or drain, are enabled to make it quite smooth and even. Shovels of different forms (fig. 680. a, b), and a scoop for lifting water (c), are also requisite.*



4396. *The crescent (fig. 679. b) is a tool made like the gardener's edging iron, only much larger, having the form of a crescent, being very thin and well steeled, with a stem about three feet long, and a cross handle to bear upon. It is used for tracing out the sides of the mains, trenches, drains, &c.*



4397. *The turf knife (fig. 681.) has a cimeter-like blade, with a tread for the foot (a) and a bent handle (b): it is used for the same purpose as the crescent, and by some preferred.*



4398. *Wheelbarrows also become necessary to remove the clods to flat places: they may be open, without sides or hinder parts.*

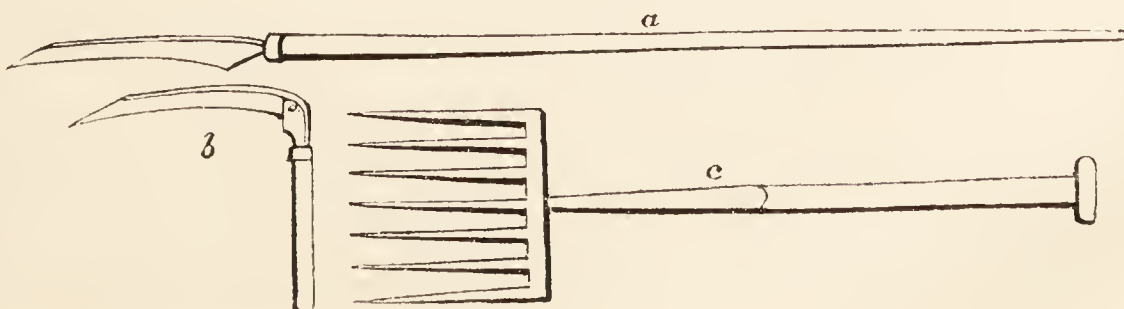
4399. *Handbarrows are likewise sometimes made use of where the ground is too soft to admit of wheelbarrows, and where clods require to be removed during the time the meadow is under water.*

4400. *Three-wheeled carts, &c. are necessary, when large quantities of carth are to be removed, particularly when it is carried to some distance.*

4401. *Scythes, of different sorts (fig. 682. a, b), are required to mow the weeds and grass, when the water is running in the trenches, drains, &c. The crooks (b) should be made light, and have long stems, to reach wherever the water is so deep that the workmen cannot work in it.*

4402. *Besides these, forks (c), and long four or five tined hacks, are requisite to pull out the roots of the sedge, rushes, reeds, &c. which grow in the large mains and drains.*

682

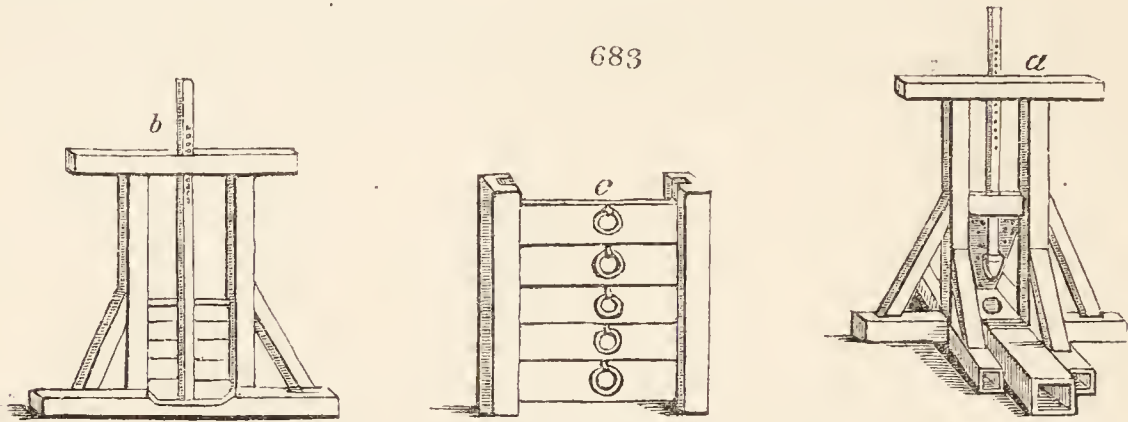


4403. *Stout large waterproof boots*, having tops so as to draw up half the length of the thigh, are indispensable; they must be large enough to admit a quantity of hay to be stuffed down all round the legs, and be kept well tallowed, to resist the running water for a length of time.

4404. *The terms made use of* are various: —

4405. *A wear* is an erection across a river, brook, rivulet, main, &c., made often of timber only, sometimes of bricks, or stones and timber, with from two to eight or ten thoroughs (openings) to let the water through, according to the breadth of the stream. Its height is always equal to the depth of the stream compared with the adjacent land. Its use is, when the hatches are all in their proper places, to stop the whole current, that the water may rise high enough to overflow the banks, and spread over the adjoining land; or, by stopping the water in its natural course, to turn it through mains cut for conveying it another way, to water some distant lands.

4406. *A sluice* (fig. 683. *a*, *b*) is made exactly as a wear, only it has but one thorough; for if there are more than one, it becomes a wear.



4407. *A trunk* is a covered sluice, being a necessary construction in all cases where two streams of water are to cross each other, to serve as a bridge for that stream which is to pass over or under the other.

4408. *A carriage* is a sort of small wooden or brick aqueduct, built open, for the purpose of carrying one stream over another, and is the most expensive conveyance belonging to the business of watering.

4409. *A drain sluice, or drain trunk*, signifies such as are placed in the lowest part of a main, as near to the head as a drain can be formed, and situated low enough to drain the main, &c. It is placed with the mouth at the bottom of the main, being let down into the bank; and from its other end a drain is cut to communicate with the nearest trench-drain. It is a contrivance to carry off the leakage through the hatches when they are shut down, to convey the water to other grounds, or to repair the main, &c.

4410. *Hatches* (fig. 683. *c*) are floodgates, variously constructed. A particular kind, which has about a foot to take off, so as to permit the water to flow over that much of the hatch where it appears to be useful in irrigation, has been employed, but is not found to answer. They are best when made whole. They may be made of any timber, but oak and elm are the best.

4411. *Head main* is a term used to signify a ditch drawn from the river, rivulet, &c. to convey the water out of its usual current to water the lands laid out for that purpose, through the means of lesser mains and trenches. The head main is drawn of various breadths and depths, according to the quantity of land to be watered, to the length, or to the fall or descent of the land it is cut through. Smaller mains are frequently taken out of the head main, at, or nearly at, right angles, to which they are usually cut. They are much smaller than the head main, and this constitutes the only difference. The use of both the large and small mains is to feed with water the various trenches which branch out into all parts of the meadow. These smaller mains are by some called carriages, but improperly, for it is confounding them with the open trunk, called by that name, as seen above.

4412. *The trench* is a narrow shallow ditch, for conveying the water out of the mains to float the land. It ought always to be drawn in a straight line from angle to angle, with as few turnings as possible. It is never made deep, but the width is in proportion to the length it runs, and the breadth of the pane between it and the trench drain. It narrows gradually to the lower end.

4413. *The trench drain* is cut parallel to the trench, and as deep, when necessary, as the tail drain water will admit. It ought always to be cut, if possible, so as to come down to a firm stratum of sand, gravel, or clay: if the latter, a spade's depth into it will be of great advantage. Its use is to carry away the water immediately after it has run over the panes from the trench. It need not be drawn up to the head of the land, by five, six, or more yards, according to the nature of the soil. Its form is the reverse of the trench, being narrower at the head, or upper part, and gradually wider, till it comes to the lower end and empties itself into the tail drain.

4414. *The tail drain* is a receptacle for all the water that runs out of the other drains, not so situated as to empty themselves into the river; and therefore it should run nearly at right angles with the trenches, but, in general it is drawn in the lowest part of the ground, and used to convey the water out of the meadow where there is the greatest descent. This is generally found in one of the fence ditches; for which reason a fence ditch is mostly used, at once fencing the meadow and draining it.

4415. *A pane of ground* is that part of the meadow which lies between the trench and the trench drain, and is the part on which the grass grows that is mown for hay: it is watered by the trenches, and drained by the trench drains, consequently there is one on each side of every trench.

4416. *A way pane* is that part of the ground which, in a properly watered meadow, lies on that side of a main where no trenches are taken out. It is watered the whole length of the main over its banks, and a drain runs parallel with the main to drain the way pane. Its use is to afford a road for conveying the hay out of the meadows, and prevent the teams from crossing all the trenches.

4417. *A bend* is a stoppage made in various parts of those trenches which have a quick descent. It is formed by leaving a narrow slip of greensward across the trench, where the bend is intended to be, cutting occasionally a wedge-shaped piece out of the middle of it. Its use is to check the water, and force it over the trench into the panes; for if it were not for those bends, it would run rapidly on in the trench, without flowing over the land as it passed along. The great art of watering meadows consists in giving to every part of each pane an equal quantity of water.

4418. *A gutter* is a small groove cut out from the tails of those trenches, where the panes run longer at one corner than the other. Its use is to carry the water to the extreme point of the pane. Those panes which are intersected by the trench and tail drains meeting in an obtuse angle, want the assistance of these gutters to convey the water to the longest side; and when, from insufficient levelling, some parts of the panes lie higher than they ought, a gutter is drawn from the trench over that high ground, which otherwise would not be overflowed. Without this precaution, unless the flats were filled up (which ought always to be done when materials can be had), the water would not rise upon it: and after the watering season was past, those places would appear rusty and brown, whilst a rich verdure would overspread the others; at hay-time, also, the grass in those places would be scarce high enough

for the scythe to touch it, whilst that around them, which had been properly watered, would from its luxuriance lie down. Though this method of treating such places is mentioned, their existence ought always to be reprobated; for every inequality in water meadows should either be levelled down or filled up. Here the irrigator's skill is shown, in bringing the water over those places to which it could not rise of itself, and in carrying it off from others where it would otherwise stagnate.

4419. *Catch drain* is a term sometimes applied to a method made use of to irrigate the land when the water is scarce, and the method is this: when a meadow is pretty long, and has a quick descent, the water is made to run swiftly down a drain or drains, in which it is stopped at different distances so as to spread it over the adjoining surface. (See *fig.* 686. p. 728.)

4420. *The bed* of a river, main, trench, &c., is the bottom of it.

4421. *Pond* means water standing upon the land, or in the tail drain, trench drains, &c., so as to injure the ground near them; and is occasioned sometimes by the flats not having been properly filled up; and at other times, when, a ware being shut close, to water some high ground above it, the water is thrown back upon the ground contiguous. In this case the lesser evil, whichever it is, must be borne with.

4422. *A turn of water* means so much land in a meadow as can be watered at one time. It is done by shutting down the hatches in all those wears where the water is intended to be kept out, and opening those that are to let the water through. The quantity of land to be watered by one turn must vary with the size of the river, main, &c. as well as with the plenty or scarcity of water.

4423. *The head of a meadow* is that part into which the river, main, &c. first enters; and the tail of a meadow is that part out of which the river, &c. last passes.

4424. *The upper side of a main*, or trench, is that side which (when the main or trench is drawn at, or nearly at, right angles with the river, &c.) fronts the part whence the river entered. Consequently the lower side is the reverse.

4425. *The upper pane* in a meadow is that pane which lies upon the upper side of the main, or trench, drawn at right angles with the river: that is, when the river, &c. runs north and south, entering at the north, and the mains and trenches are drawn east and west, all those panes which lie on the north side of the main, &c. are called the upper panes, those on the south side are called the lower. But it may be noticed, that where the mains, trenches, &c. run parallel with the river, the panes on either side are not distinguished from each other.

4426. *Meadows are of two sorts*: flowing, calculated for a flat country; and catch-work, for sloping grounds.

4427. *Flowing meadows*. Where the ground is flat, the soil is formed into beds, or broad ridges, like those met with at bleachfields. They are commonly from 30 to 40 feet wide, and nine or ten poles in length; as, in such situations, the great object is, when once brought on, to be able to carry off the water quickly. Hence it is necessary to throw up the land in high ridges, with drains between them. More of the failures in irrigation arise from the ridges not being sufficiently high, and the slopes not being sufficiently steep, than from any other cause. (*Code.*)

4428. *Catch-work meadows*. It is difficult to give an intelligible written description of the mode of making these meadows. To be properly understood, the operation must be seen. It may, however, in general be remarked, that the system is calculated for sloping grounds, and that, after the water is brought from the original stream, into a new cut, it is stopped at the end, on as high a level as the case admits of, by which means it is made to fill the trench, and run over at the side, flooding the land below. But as the water would soon cease to run equally, and would wash the land out in gutters, it has been found necessary to cut small parallel trenches, at the distance of from 20 to 30 feet, to catch the water again (hence the name originated), and the same plan of spreading or diffusing is continued, until the water reaches the main drain at the bottom of the meadow. It is a great advantage attending the catch-work system, that it is not only less expensive, but the same quantity of water will do much more work. (*Code.*)

SUBSECT. 3. *Preparation of Surfaces for Irrigation.*

4429. *Artificial irrigation*, Smith observes, is produced by diverting the water of a brook out of its accustomed channel (where there is a fall) in such a manner that, the new watercourse being kept nearly level, the space between the old and new channel may be floated; the water being brought upon the land by the new channel and taken away by the old one. Thus a constant discharge and succession of water is maintained, without such an accumulation as would make it appear bright upon the land, or without such a deficiency as would leave any part of it not perfectly floating; for the art of irrigation may be most properly called floating, not soaking nor drowning. Soaking the soil, similar to the effects produced from a shower of rain, is not sufficient for the general purposes of irrigation, nor will damming up water, and keeping it stagnant upon the surface, like that in a pond, or on the fens, produce the desired effect.

4430. *Stagnating water on land* may properly be called drowning, because it drowns or covers all the grass, thereby rendering the plants beneath it in some degree aquatic, or the herbage disposed to make such a change; whereas the herbage of a water meadow should, by the construction and good management of the latter, enjoy the full benefits of both the elements of air and water. Practice has proved that there is no better method of doing this than by keeping water passing over the surface of the land with a brisk current; not so brisk as to wash away the soil, and yet in sufficient quantity to cover and nourish the roots, but not too much to hide the shoots of the grasses: hence appears the nicety of adjusting the quantity of water; and hence it also appears, that one main drain to bring the water on the upper side of the mead, and another on the lower side to take it away, will not be adequate to all the purposes of such an accurate regulation. If the space between the upper channel or main feeder and the lower one or main drain, should therefore be wider than is proper for the good adjustment of the water, that is, so that every part of the space shall have enough water passing over it and no part too much, then that space must be divided into smaller spaces by intermediate drains, which shall catch and re-distribute the water. As the water is brought by the main feeder upon the higher

side of a piece of ground which slopes towards the main drain, and down which sloping surface the water will run very readily, it does not, to persons unacquainted with irrigation, at first sight appear necessary to make such a number of intermediate catch drains; but it is proved by experience, that, however regular the slope of ground may appear to the eye, the water will find a number of irregularities, forcing itself into gutters or channels, and defeating the purposes of irrigation; in the hollow places by excess, and in high ones by the want of water. Hence the water, which was scattered over the surface of the first space, being all collected in the catch drain, may by the skill of the floater be let out upon those parts of the bed below which appear to need the most assistance.

4431. *The work should always be well formed at first* in all cases of improvements of this nature. Temporary means of making dams and hatches to divert the water out of its usual channel may, says Smith, suffice to try an experiment, or for a tenant who has but a short term in the grounds to be irrigated; but every land-owner who enters upon such work in this temporary manner sadly mistakes his own interest: indeed, it is frequently more difficult to repair than to renew upon large streams, when the foundations are often destroyed by the force of the water. The same principle holds good upon small streams, and even in the drains and feeders of a water meadow. Wherever the channels are so constructed as to make a fall, or much increase the rapidity of the stream, it is constantly disposed to wear away the sides of its channel, or undermine a dam. To repair these defects, land must be dug away and wasted each time it is replaced, with the loss of labour. The consequent ill management of the water renders it more advisable, and perhaps cheaper, to make all such works of masonry. When works are well done at first, the owner ever finds much pleasure in viewing them; and even the labourers feel much more interested in their good management.

4432. *The expenses of making a water meadow* are not easily estimated. Much depends on the original state of the ground, the size and fall of the streams to be used, the cost of hatches, and length of the main feeders which may be necessary for diverting the water out of its original channel, and even upon the charge for levelling land, which differs materially. Some soils are much harder and more difficult to move than others, and, in certain situations, building materials are very scarce and dear. This last circumstance must make a considerable variation in the price of the hatches, where the stream is large. It is also impossible to tell, with any degree of certainty, what proportion these expenses should bear to the quantity of land irrigated, for some situations will require much more masonry than others.

4433. *Before entering upon the execution of a water meadow*, it is necessary to consider fully, whether the stream of water to be made use of will admit of a temporary wear or dam to be formed across it, so as to keep the water up to a proper level for covering the land without flooding or injuring other adjoining grounds; or if the water be in its natural state sufficiently high without a wear or dam; or can be made so by taking it from the stream higher up more towards its source; and by the conductor keeping it up nearly to its level till it comes upon the meadow or other ground: and still further, whether the water can be drawn off the meadow or other ground in as rapid a manner as it is brought on. Having, in addition to these, an attention to all such other difficulties and obstructions as may present themselves, from the lands being in lease, through which it may be necessary to cut or form the mains or grand carriers, from the water being necessary for turning mills, from the rivers or brooks not being wholly at the command of the irrigator, and from small necks of land intervening so as to prevent the work from being performed to the greatest advantage, the operator may be in a situation to commence his operations.

4434. *In order to have an equal distribution and prevent waste*, Smith states, that no part of a meadow, either in catch-work or beds, should be so formed as to be floated directly from the main feeder; but all the main feeders should be kept high enough to discharge the water into the small feeders with considerable velocity and through a narrow opening. The motion of water is truly mechanical: it requires a great deal of ingenuity, and a perfect knowledge of lines and levels, to make it move over the ground in a proper manner. No two pieces of land being exactly alike, renders it still more difficult to set out a water meadow; but even if the figure of two pieces be alike, the inequalities of surface will probably vary. Each meadow, therefore, requires a different design, unless the landowner makes up his mind to the heavy expenses of paring off banks, and filling up such hollows as may be necessary to reduce it to some regular method; the construction to be varied according to the nature of the ground. This constitutes the difference between the water meadows of Berkshire and Devonshire. Those of the latter are upon small streams carried round the sides of the hills, and are chiefly catch-work; those of the former, being near large rivers and boggy ground, are thrown up into ridges to create a brisk motion in the water, and also for the essential purpose of draining off all superfluous moisture, which might be injurious to the grasses when shut up for feeding or mowing. Where there is much floating to be done with a little water, or rather where the great fall of a small stream will admit of its being carried over a vast quantity of ground and used several times, it is desirable to employ it in such

a way as that the earthy particles it may contain may be deposited as equally as possible over the whole surface to be irrigated. But it is to be observed, that this mode of applying water must not be exhibited as a perfect model. If it should answer the purpose of a coat of manure, upon such an extent of ground, it is all that can be expected, and will amply repay the expense. Losing fall is wasting water.

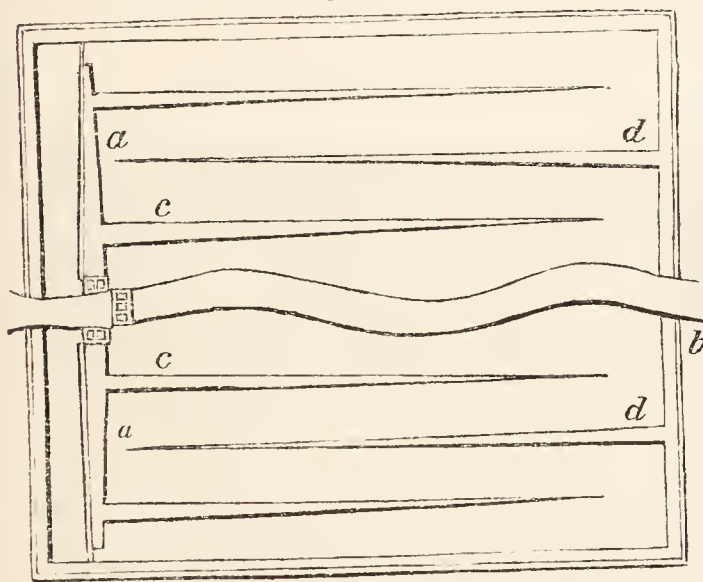
4435. *The drains of a water meadow* require no greater declivity than is necessary to carry the water from the surface : therefore the water ought to be collected and used again at every three feet of the fall, if it be not catch-work. It is sometimes difficult to do this in bed-work meads ; but where the upper part of the meadow is catch-work or in level beds, and the lower part not too much elevated, it may be done. By collecting and using the water again in the same piece of ground before it falls into the brook, a set of hatches is saved ; and it is not necessary to be very particular about getting the upper part into high ridges, since that part of the meadow which is near the hatches generally becomes the best, and the lower end of the field, being often the wettest or most boggy in its original state, requires to be thrown up the highest. If the land is of a dry absorbent nature before floating, it is not necessary that it should be thrown up into high beds, but merely as much inclined as will give the water a current.

4436. *Inclined planes are absolutely necessary for the purpose of irrigation.* To form these between straight and parallel lines, it is necessary to dig away land where it is too high, and move it to those places where it is too low, to make such a uniformity of surface. The new-made ground will of course settle in hollows proportioned to the depth of loose matter which has been recently put together, but this settlement will not take place until the new soil has been completely soaked and dried again ; therefore these defects cannot be remedied before the second or third year of watering : it will therefore require more skill to manage a water meadow for the first three or four years, than afterwards.

4437. *Properly to construct a water meadow* is much more difficult than is commonly imagined. It is no easy task to give an irregular surface that regular yet various figure which shall be fit for the overflowing of water. It is very necessary for the operator to have just ideas of levels, lines, and angles ; a knowledge of superficial forms will not be sufficient ; accurate notions of solid geometry (obtained from theory or practice) are absolutely necessary to put such a surface into the form proper for the reception of water, without the trouble and expense of doing much of the work twice over. (*Obs. on Irrigation, &c.*)

4438. *As an example of irrigating a meadow from both sides of a river,* we take the following case from

684

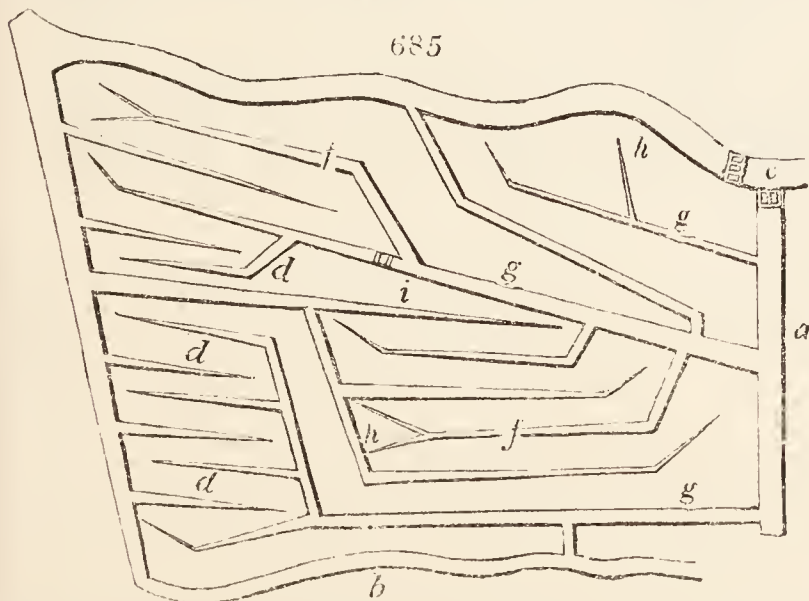


Boswell's treatise. From the upper part of the grounds, two main drains (*fig. 684. a, a*) are formed at right angles to the river, one running north, the other south, across the meadow, to within about six yards of the fence ditches which surround it (*b*) and are used for tail drains : by means of these fence ditches the water is discharged into the river. A wear erected across the river forces the water into either of the main drains, which is done by shutting the other wear close. When there is not water enough, or it is not convenient to water both parts of the meadow at once, by shutting close one of the wears, the current is forced into that main whose wear is open, thence to be conveyed through the trenches over the panes, to water that side of the meadow ; then by shutting that, and opening the other, the opposite main is filled, and by means of the trenches that side of the meadow is watered in the same manner ; and lastly, by shutting them both, and opening the river wear, the water flows in its usual course, and the land on both sides is laid dry. From the main drains (*a, a*) the

water flows along the highest part, or crowns of the ridges in the trenches (*c*), and is carried off to the tail drains by the trench drains (*d*).

4439. *As an example of an irregular surface watered from one side of a river,* we shall have recourse

685

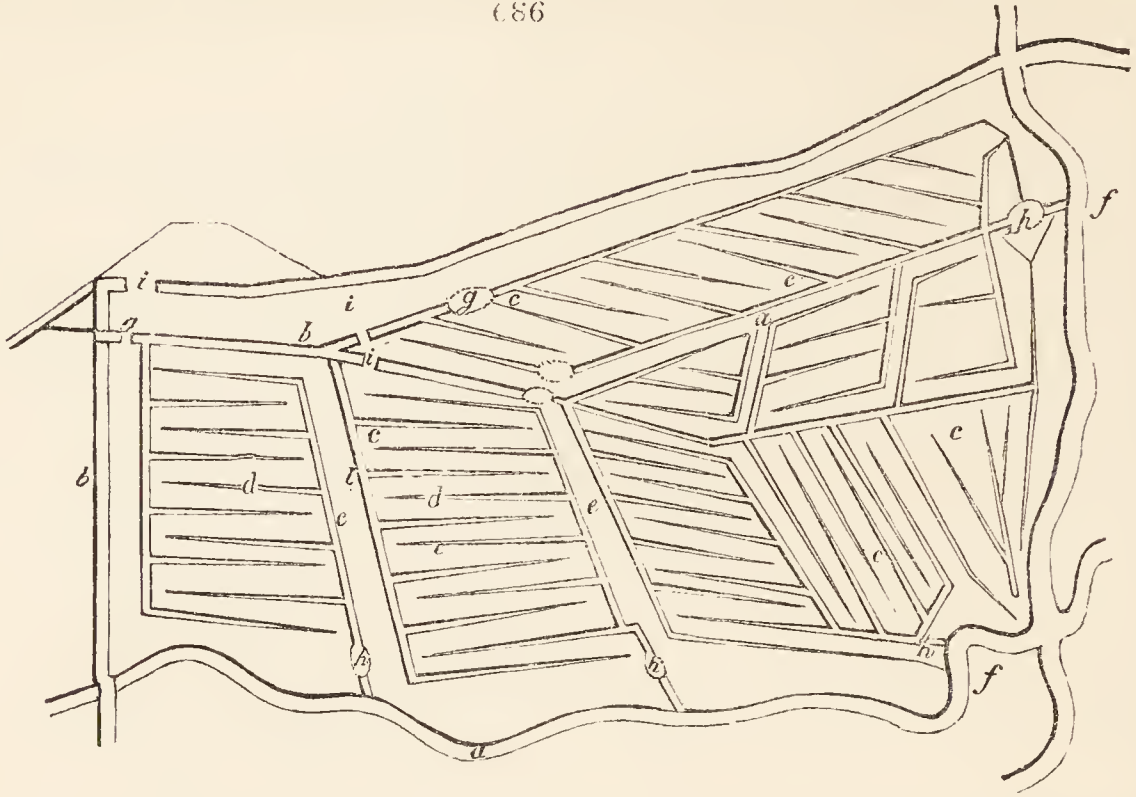


to the same author. There is a wear (*fig. 685. e*) erected across the river, and another across the head-main (*a*), from which proceed three main and branch trenches (*g, g, g,* and *f, f*), which water the whole meadow. There is a tail drain (*b*) for carrying off the whole of the water by means of the drain trenches (*d, d*). The water, having thus passed over the field, is returned to the river by the tail drain already mentioned. When it is desired to withhold the water, the wear of the head main (*a*) is shut, and that of the river (*e*) opened. It will be observed, that in this design there are branch trenches (*f, f*), and various gutters (*h, h*), taken out of the ends of some of the trenches, to carry the water to the longest corner of the panes, and sometimes taken out of different parts of the trenches, to water some little irregularities in the panes, which, without such assistance, would not have any water upon them. There

is a sluice (*i*) erected at the end of one of the small mains, to force the water into the branch trench adjoining (*f*), that being the highest ground.

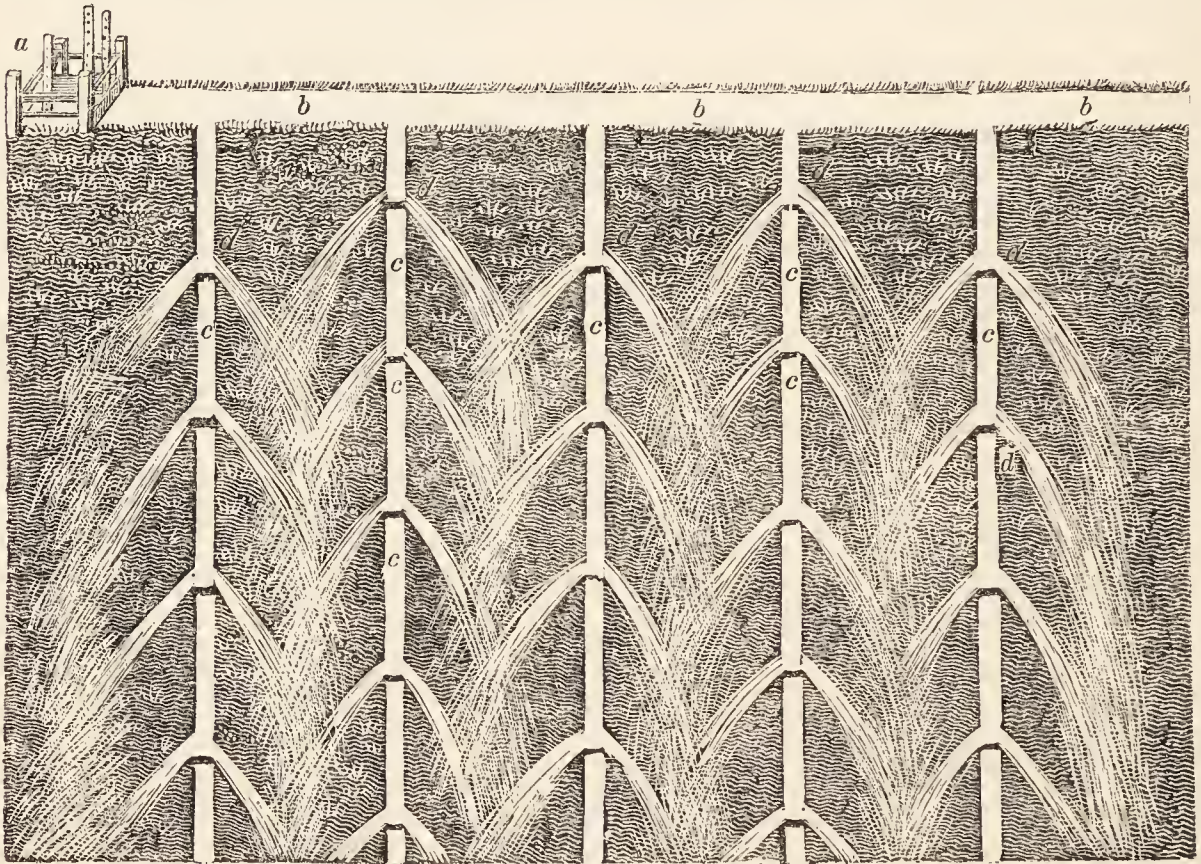
4140. A very complete piece of irrigation (fig. 686.) was formed for the Duke of Bedford, by Smith, at Pristley. The water is supplied from a brook (a), to a main feeder, with various ramifications (b, b); the

(86



surface is formed into ridges (c, c), over which the water flows, and is carried off by the drains in their furrows (d, d), to the main drains (e, e), and to the brook at different places (f, f). There are bridges (g) over the main feeders, small arches over the main discharging drains (h), and three hatches (i).

4441. As an example of catch-work watering, we may refer to a case (fig. 687.), given in a recent work



by John Brown. (*Treatise on Irrigation*, 1817.) In this the field of operations being on the steep side of a hill, a main carrier is led from the sluice (a), directly across the declivity (b), and lateral feeders (c) taken out from it at regular distances. These feeders have stops of turf, at regular distances (d), by which means the water is dispersed. After watering a space of from twenty to forty feet in breadth, it is again collected by the small drains in the furrows, and returned lower down to another feeder. The advantage of this method, Browne observes, "relates more materially to the sides of hills, and to porous soils that are by some thought incapable of being watered. The chief point is to get the water to the highest level possible; and in case the soil be porous, one main carrier only will require puddling, in order to prevent the water from sinking away: when that is done, no difficulty whatever is found in taking it in small streams vertically, or directly down the slope (c), and putting stops (d) to arrest its progress occasionally, which will throw it on each side; and when those stops are placed one above another, it will have the effect of spreading the water on the land, somewhat similar to a fan when extended. The stops need only be sods or turfs, one laid lengthways in the gutter, and one across it, which may be raised or lowered according to the declivity: these sods or turfs will require probably a small wooden peg to fasten them at first; and by the time the land requires a second watering, the roots of the grass will have sufficiently fastened them; and they need not be removed, unless occasionally for the purpose of watering any separate part below, when the stream may be too small to water the whole piece at once; and the small cuts for conveying the water will be less expensive in cleaning, not being so liable to choke up as

those carried on what is termed horizontal or level gutters. In some places in Essex, it is the practice to irrigate during winter by means of the water of occasional floods. Sometimes this water is obtained from the ditches along the sides of the roads, and from the drainages of villages; and in these cases is more or less enriched by earthy materials.

4442. *As an example of the benefit of flooding*, we refer to Loch Ken, in Kircudbrightshire, the most striking instance known in Great Britain of advantage being derived from the inundations of a lake. At the head of that beautiful piece of water, there is a flat of about 240 statute acres, which is rendered, by flooding, one of the richest spots in Scotland. Many acres in it produce at the rate of three tons of hay each, and some parts of it have been cropped with grain for twenty-five years in succession, without any manure, except what it receives from the inundations it experiences. These, however, leave behind them a variety of enriching substances. (*Statistical Account of Scotland*, vol. iv. p. 260.)

4443. *Floating upwards*. The ancient and now obsolete practice of flooding, or, as it was termed, of floating upwards, was practised in various parts of the kingdom. For that purpose, the water was penned, in times of floods, by means of a dam or floodgate across the bottom of the meadow or flat to be watered. The waters were not suffered to remain long upon the land, but were let off as soon as it was judged that they had deposited their sediment. The benefit arising from this method of using floodwaters, it is said, was considerable; but when the improved mode of irrigation by floating ridges was introduced, and found more advantageous, the other was discontinued. (*Marshal's Midland Counties*, Minute 27.)

4444. *Watering land by machinery*. If the land be put in a proper form for irrigation, and supplied with a good stream at proper seasons, there can be no difference from the method of getting it on the surface; and if all other circumstances are equally favourable, the same fertility may be expected from water thrown up by a drain-mill, as from that which runs from a brook. (*Smith's Observations on Water Meadows, &c.* p. 93.) A cheap and effectual power for raising water in sufficient quantities to flow about ten acres at a time, would be an invaluable acquisition; for a productive water meadow is probably the true mark of perfection in the management of a farm. (*Middlesex Report*, p. 322.)

4445. *Sea water*. Smith suggests the idea of employing machinery to raise not only fresh but even sea water for irrigation. (*Observations*, p. 87.) It is well known how much all kinds of stock are improved by salt marshes, and how beneficial to them is a moderate quantity of saline matter. There are many parts of the kingdom where, by the aid of machinery, these advantages might be obtained at a moderate expense. (*Code*.)

4446. *The expense of irrigation* varies according to the nature of the work. Where the catch-work system is practicable, in favourable situations, the forming may be done as low as ten shillings per acre. This fact is, in many cases, decisively in favour of this natural and simple mode, which requires also much less water, and often answers fully as well as flat flooding. (*General Report*, vol. ii. p. 598.) The expense of bed-work, as it is called, is, however, considerable. If the ground to be flooded be smooth on its surface, or in regular ridges, and if the water can easily be brought to the meadow, with a temporary wear, supposing the extent to be almost twenty acres, it may be done at from 5*l.* to 10*l.* per acre: but if the land be of large extent, with an irregular surface; if a large conductor and a proper wear shall be required, with hatches both in it and also in the feeders; and if the aid of a professional person, to lay out and oversee the work, be necessary (which is generally the case), the expense will vary from 10*l.* to 20*l.* per acre. (*General Report*, vol. ii. p. 598.) Nay, in Wiltshire, where they are anxious to have their meadows formed in the most perfect manner, with that regularity which the nice adjustment of water demands, the expense per acre has amounted to 40*l.* (*Smith's Observations on Irrigation*, p. 56.)

4447. *Objections to irrigation* have been made on the supposition that it renders a country unhealthy; but as the water is continually kept in motion, this is not likely to be the case, and indeed is found not to be so in Gloucestershire, Lombardy, and other places where it is extensively practised. It is also thought that though the produce may be increased, it becomes in a few years of so coarse a nature, mixed with rushes and water plants, that cattle frequently refuse to eat it; and when they do, their appearance proclaims that it is far from being of a nutritious quality. (*Rutland Report*, p. 114.) But this objection is never applicable to meadows skilfully made and properly managed; and whenever the grasses are coarse, if intended for hay, they should be cut earlier. Rushes and water plants are proofs that the meadow lies too flat and is ill managed. (*Code*.)

4448. *The principal impediments to irrigation* are the claims of different individuals on one stream, as millers, canal owners, &c.; the intermixture of property and interests; and the existence in some cases of adverse leases.

4449. *The formation and arrangement of surfaces* for irrigation, however simple in principle, is in practice one of the most difficult operations of agricultural improvement. Whoever, therefore, contemplates extensive and intricate works of this kind will find it desirable to call in the assistance of a professor and contractor of reputation. In Gloucestershire there are a class of men known as "flooders," who have under them a com-

pany of men accustomed to every part of the work, and who accompany their chief to execute works in any part of the country.

SECT. II. *Warping, or the Improvement of Land by muddy Water.*

4450. *Warping* is a mode of fertilising lands by depositing a coat of mud on their surface. This may be practised on the borders of large rivers and estuaries into which sea tides flow, or where floods are frequent; provided, however, that in either case the waters contain alluvial matters in a state of suspension. According to the best information that can be obtained (*Marshal, in R. Econ. of York., 1788. Day, West Riding Report, p. 171.*), warping was first practised on the banks of the Humber, by one Barker, a small farmer at Rawcliff, between 1730 and 1740: it was afterwards extended by Richard Jennings, of Armin, near Howden, in 1743; but, till about the year 1753, it was not attempted by any other person. It was first brought into notice by Marshal, in 1788, and subsequently in the *Report of the West Riding of Yorkshire*, and is now practised by various proprietors and farmers on the Humber, the Trent, and other rivers. It has been long practised in Italy in a manner something different from that employed in this country. It may be considered as of Egyptian origin.

4451. *The theory of warping* is thus given by Arthur Young: —

4452. *The water of the tides* that come up the Trent, Ouse, Dun, and other rivers which empty themselves into the great estuary of the Humber, is muddy to an excess; insomuch that in summer, if a cylindrical glass, twelve or fifteen inches long, be filled with them, it will presently deposit an inch, and sometimes more, of what is called warp. Where this warp comes from is a dispute: the Humber, at its mouth, is clear water; and no floods in the countries washed by the warp rivers bring it, but, on the contrary, do much mischief by spoiling the warp. In the very driest seasons and longest droughts, it is best and most plentiful. The improvement is perfectly simple, and consists in nothing more than letting in the tide at high water, to deposit the warp, and permitting it to run off again as the tide falls: this is the aim and effect: but to render it efficacious, the water must be at command, to keep it out and let it in at pleasure; so that there must not only be a cut or canal made to join the river, but a sluice at the mouth to open or shut, as wanted: and, that the water may be of a proper depth on the land to be warped, and also prevented from flowing over contiguous lands, whether cultivated or not, banks are raised around the fields to be warped, from three or four to six or seven feet high, according to circumstances. Thus, if the tract be large, the canal which takes the water, and which, as in irrigation, might be called the grand carrier, may be made several miles long: it has been tried as far as four, so as to warp the lands on each side the whole way, and lateral cuts made in any direction for the same purpose; observing, however, that the effect lessens as you recede from the river; that is, it demands longer time to deposit warp enough for producing benefit.

4453. *The effect of warping* is very different from that of irrigation: for it is not the water that works the effect, but the mud; so that in floods and in winter the business ceases; and it is not the object to manure the soil, but to create it. The nature of the land intended to be warped is not of the smallest consequence: bog, clay, sand, and peat, are alike eligible; as the warp raises it in one summer from six to sixteen inches thick, and in the hollows or low places, two, three, or four feet, so as to leave the whole piece level. Thus a soil of any depth you please is formed, which consists of mud of a vast fertility, though containing not much besides sand and gravel.

4454. *The method of executing the work* is described in the following manner by Lord Hawke, in *The Agricultural Survey of the West Riding of Yorkshire*: —

4455. *The land to be warped* must be banked round against the river. The banks are made of the earth taken on the spot from the land: they must slope six feet; that is, three feet on each side of the top or crown of the bank, for every foot perpendicular of rise: their top or crown is broader or narrower, according to the impetuosity of the tide, and the weight and quantity of water; and it extends from two feet to twelve: their height is regulated by the height to which the spring tides flow, so as to exclude or let them in at pleasure. In these banks, there are more or fewer openings, according to the size of the ground to be warped, and to the choice of the occupier; but in general they have only two sluices; one called the floodgate, to admit, the other, called the clough, to let off, the water gently: these are enough for ten or fifteen acres. When the spring tide begins to ebb, the floodgate is opened to admit the tide, the clough having been previously shut by the weight of the water brought up the river by the flow of the tide. As the tide ebbs down the river, the weight or pressure of water being taken from the outside of the clough next the river, the tide water that has been previously admitted by the floodgate opens the clough again, and discharges itself slowly but completely through it. The cloughs are walled on each side, and so constructed as to let the water run off, between the ebb of the tide admitted and the flow of the next; and to this point particular attention is paid. The floodgates are placed so high as only to let in the spring tides when opened: they are placed above the level of the common tides. Willows are also occasionally planted on the front of the banks, to break the force of the tides, and defend the banks by raising the front of them with warp thus collected and accumulated; but these willows must never be planted on the banks, as they would destroy them by giving the winds power to shake them.

4456. *The season for warping* begins in the month of July, and continues during the summer; and as this sort of business can only be performed at that season, every occasion of having it executed should be embraced, by having the work in perfect repair, that every tide may be made to produce its full effect. With regard to the advantage of doing this work in the summer months, it may be remarked that at these times the lands not only become the soonest dry, a circumstance which must always fully take place before the process of cultivation can be carried on; but the tides are less mixed with fresh water, in which condition they are constantly found the most effectual.

4457. *The expense of this mode of improving lands* must differ much in different cases, according as the circumstances of situation and distance vary; but it can seldom exceed

12*l.* or 15*l.* the acre, according to Young, and in most instances it must be greatly below such estimates.

4458. *That no estimate can be made without viewing the situation of the lands to be warped*, and the course and distance it will be necessary to carry the warp to such lands, is remarked by Day, in the *Agricultural Survey* of the same district. 1st, The situation of the lands must be considered; 2d, The quantity of land the same drains and cloughs will be sufficient to warp; 3d, The expense of building the cloughs, cutting the drains, embanking the lands, &c. An estimate of these expenses being made, it will then be necessary to know the number of acres such cloughs and drains will warp, before any estimate can be made; as the greater the quantity of land the same cloughs and drains will warp, the lighter the expense will be per acre. In Day's opinion, there is a great deal of land in the country capable of being warped at so small an expense as from 4*l.* to 8*l.* per acre, which is nothing in comparison to the advantages which arise from it. He has known land raised in value by warping, from 5*l.* to upwards of 40*l.* and 50*l.* per acre. The greatest advantages arise upon the worst land, and the more porous the soil the better, as the wet filters through, and it sooner becomes fit for use. The advantages of warping are very great; as, after lands have been properly warped, they are so enriched thereby that they will bring very large crops for several years afterwards without any manure; and, when it is necessary, the lands might be warped again, at a very trifling expense, by opening the old drains, and would bring crops in succession for many years, with very little or no tillage at all, if the lands were kept free from quick grass and other weeds, which must be the case in all properly managed lands; besides, the drains which are made for the purpose of warping are the best drains that can be constructed for draining the lands at the time they are not used for warping, which is another very great advantage in low lands.

4459. *The best mode of cultivating new-warped land* must depend principally on the nature of the warp and of the subsoil. In the *Code of Agriculture* it is recommended to sow it with clover, and to let it lie under that crop for two years, in order that it may be brought into a state fit for corn. Even though fallowed, it does not answer to sow land with wheat immediately after it is warped; but after white or red clover for two years, a good crop of wheat may generally be relied on. Nor is it proper, when land is warped, to plant it with potatoes, or to sow it with flax, being at first of too cold a nature; though, if the land be not too strong for potatoes, these crops may answer, after it has been for two or three years in cultivation. In the quality of warped land, there are most essential differences; some will be very strong, and in the same field some will be very friable. The land nearest the drain is in general the lightest, owing to the quantity of sand that is deposited as soon as the water enters the field: the land farthest from the drain is in general the best. The produce of warped land varies much, but in general it may be stated as abundant. (*Code*, 315.)

SUBJECT. 1. *Irrigation of Arable Lands, and Subterraneous Irrigation.*

4460. *The irrigation of arable lands* is universal in warm countries, and even in the south of France and Italy. The land is laid into narrow beds, between which the water is introduced in furrows during the growth of the crop, and absorbed by the soil. In other cases the crop is grown in drills, and the water introduced in the furrow between each row. In this mode of irrigation no collecting drains are required, as the whole of the water laid on is absorbed by the soil. The principal expense of the operation is that of preparing the lands by throwing the surface into a proper level or levels. The main or carrier is conducted to the higher part of the field, and the rest is easy. A particular description of the practice, as carried on in Tuscany, is given by Sigismondi. (*Agr. de la Toscane.*) Some account also of the practice in Italy and the East Indies will be found in our outline of the agriculture of these countries. (267 and 921.) In the *General Report of Scotland*, vol. iii. p. 361. it is stated, that a field of waste land, which had been flooded during winter with stagnant water, was thus, without manure, rendered capable of yielding a good crop of oats; but this is more of the nature of warping than of that description of irrigation which is practised in warm countries on arable lands, during the growth of the crop.

4461. *Subterraneous irrigation* appears to have been first practised in Lombardy, and first treated of by Professor Thouin. (*Annales du Musée, &c.*) It consists in saturating a soil with water from below, instead of from the surface, and is effected by surrounding a piece of ground by an open drain or main, and intersecting it by covered drains communicating with this main. If the field is on a level, as in most cases where the practice is adopted in Lombardy, nothing is more necessary than to fill the main, and keep it full till the lands have been sufficiently soaked; but if it lies on a slope, then the lower ends of the drains must be closely stopped, and the water admitted only into the main on the upper side: this main must be kept full till the land is soaked, when the mouths of the lower drains may be opened to carry off the superfluous water. The practice is applicable either to pasture or arable lands.

4462. *In Britain*, subterraneous irrigation has been applied in a very simple manner to drained bogs and morasses, and to fen lands. All that is necessary is to build a sluice in the lower part of the main drain where it quits the drained grounds, and in dry weather to shut down this sluice, so as to dam up the water and throw it back into all the minor open drains, and also into the covered drains. This plan has been adopted with success, first, as we believe, by Smith, of Swineridge Muir, in Ayrshire, and subsequently by Johnston, in the case of several bog drainages executed by him in Scotland.

It is also practised in Lincolnshire, where it was introduced by the advice of the late engineer Rennie, after the completion of a public drainage at Boston.

SECT. III. *Artificial Means of Procuring Water for the Use of Live Stock.*

4463. *Water is supplied by nature in most parts of the British isles, and retained with little art both at farmeries and in fields.* There are exceptions, however, in different districts, and especially in chalky soils, gravels, and some upland clays. In these cases water is procured for cattle by some of the following means:—By conducting a stream from a distant source, as in a work of irrigation; by collecting rain-water from roads, ditches, or sloping surfaces, in artificial ponds, or reservoirs; by collecting it from the roofs of buildings, and preserving it in covered cisterns; by sinking a well, or a pipe, either in the field or the farm-yard; and by artificial springs.

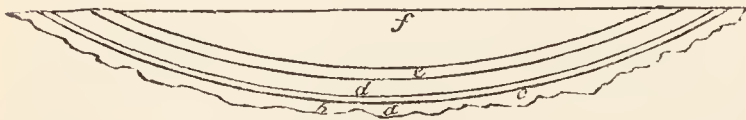
4464. *An artificial stream* will in most cases be found too expensive an operation to be undertaken for the supply of drinking-water for live stock; but this purpose may frequently be combined with that of watering lands or driving machinery. In the North Riding of Yorkshire, there is a tract extending for many miles entirely destitute of water, except what flows along the bottoms of the deep valleys by which it is intersected; and little relief could consequently be afforded, by streams thus distantly and inconveniently situated, to the inhabitants of the uplands, or their cattle. About the year 1770, a person of the name of Ford devised the means of watering this district, by means of rills brought from the springs that break out at the foot of the still loftier moorland hills that run parallel to, and to the north of, this tract, in some instances at the distance of about ten miles. The springs he collected into one channel, which he carried, in a winding direction, about the intervening space, according to its level, and along the sides of the valleys, until he gained the summit of the arid country which he wished to supply with water; and when this was accomplished, the water was easily conveyed to the places desired, and also to the ponds in all the fields, over a considerable tract of ground.

4465. *Collecting rain-water from roads, &c. in ponds or drinking pools.* Formerly, it is probable, something of this art was practised throughout the kingdom: most villages, and many old farmsteads, have drinking pools for stock, which appear to have been formed or assisted by art. In strong-land grazing districts, pits have evidently been dug, to catch the rain-water fortuitously collected by furrows and ditches, or by land-springs. On the chalk hills of the southern counties, the art has been long established, and continued down to the present time.

4466. *An improved practice* was introduced on the wolds or chalk hills of Yorkshire by Robert Gardner, of Kilham, which gained an establishment towards the end of the last century, and has spread rapidly over the adjacent heights, with great profit to the country. In every dry-land situation, it may be practised with high advantage to an estate, and is well entitled to attention.

4467. *The mode of constructing these collecting ponds* is described in *The Annals of Agriculture* (vol. vi.), and illustrated by a section. (fig. 688.)

688



thickness, is finely and uniformly spread. Next is another layer of clay of about one foot in thickness (*d*), which is to be trodden and rammed down as the former. Upon this are spread stones or coarse gravel (*e*), of such thickness as may prevent the pond receiving any injury from the treading of cattle, which would otherwise break through the body of the clay and lime, and by so doing let out the water. After this, the pond will remain five feet deep and forty-five feet in diameter; the size they are usually made.

4468. *Brick-clay is by no means required* for the ponds; any earth sufficiently tenacious to bear beating into a solid compact body, though not approaching to a pure clay, will answer the purpose very well.

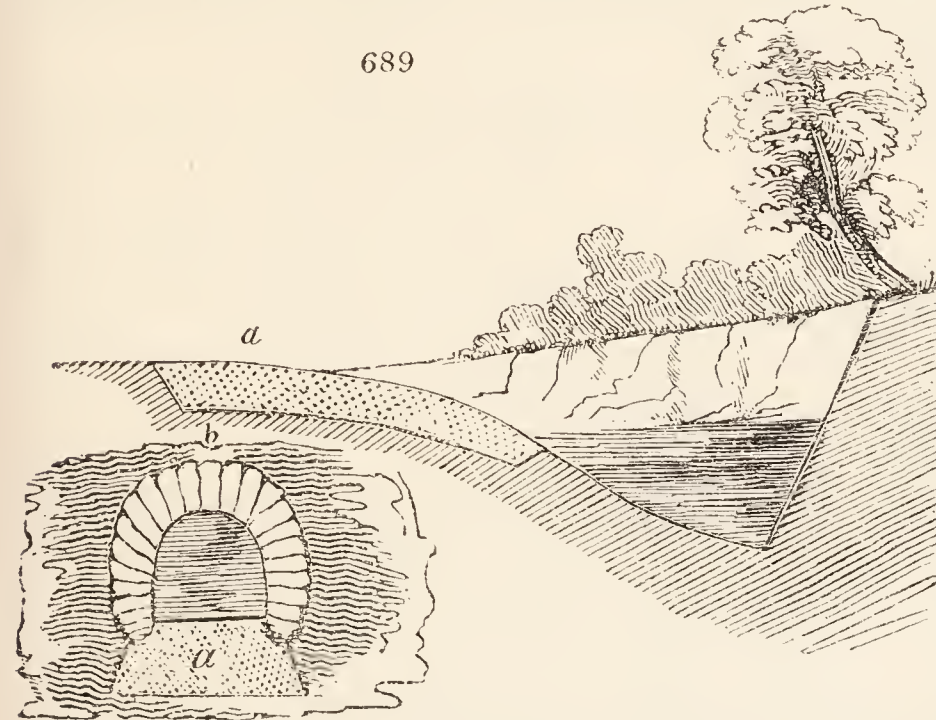
4469. *The preferable situation to make the pond* is a little valley, or at the bottom of a declivity, or near a high road, in which situation a stream of water may be brought into it after sudden showers or thaws, the object being to get it filled as soon as possible after it is made, that the sun and winds may not crack the clay. If it is not likely to be filled soon, some straw or litter must be spread over it; but in general, after it is once filled, the rains that fall in the course of the year will keep it full, no water being lost otherwise than by evaporation and the consumption of cattle.

4470. *The whole excellence of the pond depends upon the lime*: care must be taken to spread it regularly and uniformly over the surface of the lower bed of clay. It is well known that ponds made of clay alone, however good its quality, and whatever care may be bestowed in the execution, will frequently not hold water: these, with the above precautions, rarely fail. By what means the lime prevents the loss of water is not exactly known: one of these two is probably the cause: either the lime sets like terrace into a body impervious to water; or its causticity prevents the worms in dry weather from penetrating through the clay in search of the water: certain, however, it is, that, with lime thus applied, ponds may be made in sand, however porous, or on rocks, however open, in neither of which situations are they to be depended upon when made with clay alone. On this mode of making ponds for the use of live stock, there are several circumstances of the process more fully detailed in *The Rural Economy of Yorkshire*.

4471. *In constructing ponds in loamy soils*, all that is necessary is to coat the bottom over with clay or loam to the depth of eighteen inches or two feet, and then to puddle or work this well with water till it becomes a homogeneous layer impenetrable to that element. If clay or loamy earth cannot be obtained, any earth not very much inclined to sand may be substituted, but it will require more labour in puddling.

On clayey soils very little more is necessary than smoothing the surface of the excavation, and perhaps watering it and beating it to a smooth surface with rammers. The pond being now formed, the next operation is to coat it over with coarse gravel to the depth of at least eighteen inches; or, what is preferable, chalk and flints with gravel; or, best of all, to causeway or pave it. It is also very desirable

689



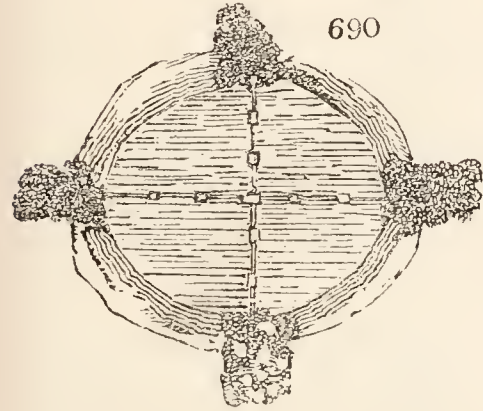
to pave or gravel the surface for the breadth of at least two yards round the pond, in order to prevent the cattle from poaching it when they come to drink.

4472. On clayey soils an economical mode of forming ponds is often adopted, where gravel or stone for paving is scarce. It consists in employing the horse-shoe form as the ground plan of the excavation, and cutting all the sides steep, or at an angle of 45 or 50 degrees, except the part answering to the heel of the shoe (*fig. 689 a*), which is well gravelled or paved, as the only entrance for the cattle. The excavated earth serves to raise the high side of the pond (*b*), which is generally guarded by a fence, or a few trees. The disadvantage of such ponds is, that one is required for every field, or at least for every two fields;

whereas a pond sloped on all sides may supply four fields, or even a greater number. (*fig. 690.*)

4473. The Gloucestershire ponds are made either of a square or a circular shape, and generally so situated as to furnish a supply to four fields. (*fig. 690.*) Three layers of clay, free from the smallest stone or gravel, are so worked in as to form an impenetrable cement. The whole is afterwards covered with sand, and finished with pavement. (*Gloucestershire Report, p. 31.*)

690



4474. The Derbyshire artificial meers, or cattle ponds, are made in their dry rocky pastures, with great success. Having selected a low situation for the purpose, they form an excavation ten or twenty yards across, and spread over the whole a layer, about five inches thick, of refuse slaked lime and coal cinders; then they spread, trample, and ram down a stratum of well tempered clay, about four inches thick; and upon this they spread a second bed of clay, in a similar manner, of the same thickness; the whole of the bottom and edges of the meer is then paved with rubble stones; and small rubble stones, several inches thick, are spread upon the pavement. (*Derbyshire Report, vol. i. p. 494.*)

4475. The situation of field ponds, where practicable, should be at the intersection of fences, so that one may serve as many fields as possible. This, however, cannot be the best situation in every case, because it may happen that water cannot there be collected. At the same time a low situation is not always desirable, because it may be so circumstanced that too much dirty water may run into it during rains.

4476. Trees are frequently planted round ponds, and with seeming propriety, as their effect is beautiful, and they shade the water from the direct influence of the sun during summer; but in autumn their leaves certainly tend to render the water impure for a time. As most leaves are of an astringent quality, perhaps there may be no injury sustained by cattle from drinking such water at first; but after some time the leaves begin to decay, and occasion a sort of fermentation, which, till it subsides in the beginning of frosty weather, renders the water somewhat unhealthy and very unsightly. Leaves therefore ought to be drawn off with long open rakes as they fall from the trees.

4477. Wells, where no better method of procuring water can be devised, may be resorted to, both for fields and farmeries; but the great objection to them is the labour required to pump up or otherwise raise the water, and the consequent risk of neglect. Before proceeding to dig a well, it ought first to be determined on whether a mere reservoir for the water which oozes out of the surface soil is desired or obtainable, or a perpetual spring. If the former is the object in view, a depth of fifteen or twenty feet may probably suffice, though this cannot be expected to afford a constant supply, unless a watery vein or spring is hit on: if the latter, the depth may be very various, there being instances of 300 and 500 feet having been cut through before a permanent supply of water was found. (*Middlesex, Surrey, and Hampshire Reports.*)

4478. The art of well-digging is generally carried on by persons who devote themselves exclusively to that department. The site being fixed on, the ground-plan is a circle, generally of not more than six or eight feet in diameter: the digger then works down by means of a small short-handled spade, and a small implement of the pick-axe kind; the earthy materials being drawn up in buckets by the hand or a windlass, fixed over the opening for the purpose. Where persons conversant with this sort of business are employed, they usually manage the whole of the work, bricking round the sides with great facility and readiness; but in other cases it will be necessary to have a bricklayer to execute this part of the business.

4479. Steining. There are two methods of building the stone or brick within the well, which is called the steining. In one of these a circular ring is formed, of the same diameter as the intended well; and the timber of which it is composed is of the size of the brick-courses with which the well is to be lined. The lower edge of this circle is made sharp, and shod with iron, so that it has a tendency to cut into the ground; this circular curb is placed flat upon the ground, and the bricks are built upon it to a considerable height, like a circular wall. The well-digger gets within this circle, and digs away the earth at the bottom; the weight of the wall then forces the kirb and the brickwork with which it is loaded to descend into the earth, and as fast as the earth is removed it sinks deeper, the circular brick wall being increased or raised at top as fast as it sinks down; but when it gets very deep, it will sink no longer, particularly if

it passes through soft strata; in this case, a second kirb of a smaller size is sometimes begun within the first. When a kirb will not sink from the softness of the strata, or when it is required to stop out water, the bricks or stones must be laid one by one at the bottom of the work, taking care that the work is not left unsupported in such a manner as to let the bricks fall as they are laid: this is called under-pinning.

4480. *Noxious air.* Well-diggers experience sometimes great difficulty from a noxious air which fills the well, and suffocates them if they breathe it. The usual mode of clearing wells of noxious air is, by means of a large pair of bellows, and a long leathern pipe, which is hung down into the well to the bottom and fresh air forced down by working the bellows.

4481. *The use of the auger* is common in well-digging, both in ascertaining before commencement the nature of the strata to be dug into, and also in course of digging for the same purpose; and because, by boring in the bottom of a well to a considerable depth, the spring is sometimes hit upon, and digging rendered no longer necessary.

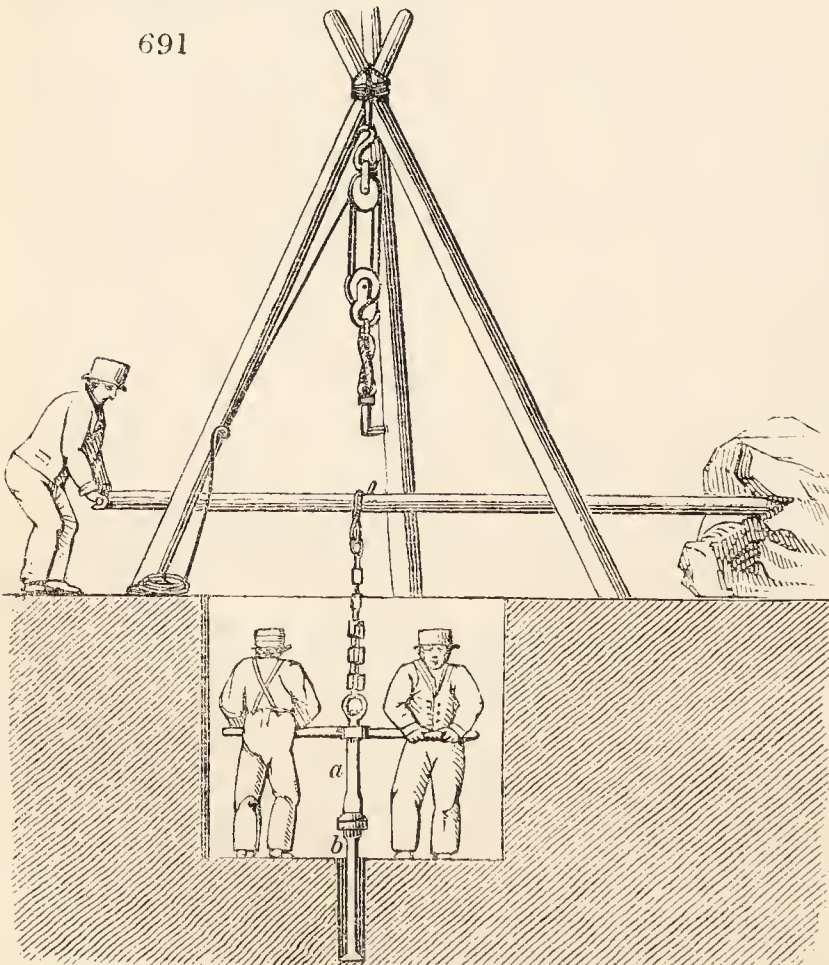
4482. *The use of the borer alone may procure an adequate supply of water* in particular situations. This mode appears to have been long resorted to in this and other countries. From what we have already stated as to the disposition of strata, the conditions requisite for its success will be readily conceived; viz. watery strata connected with others on a higher level: the pressure of the water contained in the higher parts of such strata on that in the lower will readily force up the latter through any orifice, however small. All that is necessary, therefore, is to bore down to the stratum containing the water, and, having completed the bore, to insert a pipe, which may either be left to overflow into a cistern, or it may terminate in a pump. In many cases, water may be found in this way, and yet not in sufficient quantity and force to rise to the surface; in such cases a well may be sunk to a certain depth, and the auger-hole made, and the pipe inserted in it in the bottom of the well. From the bottom it may be pumped up to the surface by any of the usual modes.

4483. *As an example of well-digging combined with boring*, we give that of a well dug at a brewery at Chelsea, Middlesex, in 1793. The situation was within 20 or 30 feet of the edge of the Thames, and the depth 394 feet, mostly through a blue clay or marl. At the depth of nearly fifty feet a quantity of loose coal, twelve inches in thickness, was discovered: and a little sand and gravel was found about the same depth. The well-digger usually bored about ten, fifteen, or twenty feet at a time lower than his work as he went on; and on the last boring, when the rod was about fifteen feet below the bottom of the well, the man felt, as the first signal of water, a rolling motion, something like the gentle motion of a coach passing over pavement: upon his continuing to bore, the water presently pushed its way by the side of the auger with great force, scarcely allowing him time to withdraw the borer, put that and his other tools into the bucket, and be drawn up to the top of the well. The water soon rose to the height of two hundred feet.

4484. *In a case which occurred in digging a well at Dr. Darwin's*, near Derby, the water rose so much higher than the surface of the ground, that, by confining it in a tube, he raised it to the upper part of the house. (*Rees's Cyclopædia*, art. *Well*, and *Derbyshire Rep.*)

4485. *The process of boring the earth for spring water* has of late been practised, with great success, in various parts of England, chiefly by a person named Goode, of Huntingdon. In the neighbourhood of London, many fountains of pure spring-water have lately been obtained by these means. We may particularly name those at Tottenham, Middlesex, and Mitcham, Surrey, both of which afford a continuous and abundant flow of water, at one time equal to about eight gallons per minute, but now reduced to a much smaller quantity, in consequence of the great number of holes that have been bored into the supplying strata.

4486. *The operation of boring for water* (*fig. 691.*) is thus performed:—The situation of the intended well



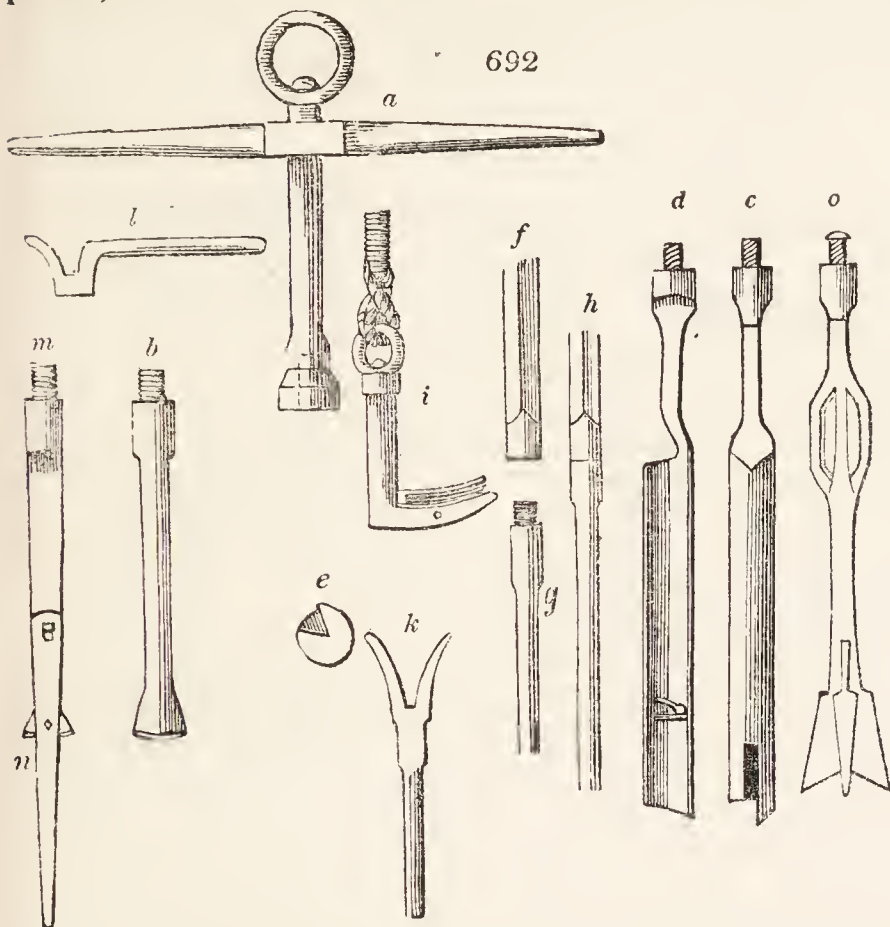
being determined on, a circular hole is generally dug in the ground, about six or eight feet deep, and five or six feet wide. In the centre of this hole, the boring is carried on by two workmen, assisted by a labourer above. (*fig. 691.*) The implements used may either be those of Goode, already described (§ 2507.) as the best, or any other instruments in repute. For variety's sake, we shall here describe the process by the instruments formerly in most general use about London. The handle (*fig. 691. a*) having a female screw in the bottom of its iron shank, a wooden bar or rail passing through the socket of the shank, and a ring at top, is the general agent, to which all the boring implements are to be attached. A chisel (*b*) is first employed, and connected to this handle by its screw at top. If the ground is tolerably soft, the weight of the two workmen, bearing upon the cross-bar and occasionally forcing it round, will soon cause the chisel to penetrate; but if the ground is hard or strong, the workmen strike the chisel down with repeated blows, so as to pick their way, often changing their situation by walking round, which breaks the stone, or other hard substances, that may happen to obstruct its progress.

4487. *The labour is very considerably reduced* by means of an elastic wooden pole placed

horizontally over the well, from which a chain is brought down, and attached to the ring of the handle. This pole is usually made fast at one end as a fulcrum, by being set into a heap of heavy loose stones; at the other end the labourer gives it a slight up and down vibrating motion, corresponding to the beating motion of the workmen below,

by which means the elasticity of the pole in rising lifts the handle and picker, and thereby very considerably diminishes the labour of the workmen.

4488. When the hole has been thus opened by a chisel, as far as its length would permit, the chisel is withdrawn, and a sort of cylindrical auger (c) attached to the



handle (a), for the purpose of drawing up the dirt or broken stones, which have been disturbed by the chisel. A section of this auger (d) shows the internal valve. The auger being introduced into the hole, and turned round by the workmen, the dirt or broken stones will pass through the aperture at bottom (shown at e), and fill the cylinder, which is then drawn up, and discharged at the top of the auger, the valve preventing its escape at bottom.

4489. In order to penetrate deeper into the ground, an iron rod (f) is now to be attached to the chisel (b), by screwing on to its upper end, and the rod is also fastened to the handle (a), by screwing into

its socket. The chisel, having thus become lengthened by the addition of the rod, is again introduced into the hole, and the operation of picking or forcing it down is carried on by the workmen as before. When the ground has been thus perforated, as far as the chisel and its rod will reach, they must be withdrawn, in order again to introduce the auger (c), to collect and bring up the rubbish, which is done by attaching it to the iron rod, in place of the chisel. Thus, as the hole becomes deepened, other lengths of iron rods are added, by connecting them together (f and g when joined form h). The necessity of frequently withdrawing the rods from the hole, in order to collect the mud, stones, or rubbish, and the great friction produced by the rubbing of the tools against its sides, as well as the lengths of rods augmenting in the progress of the operation, sometimes to the extent of several hundred feet, render it extremely inconvenient, if not impossible, to raise them by hand. A tripodal standard is therefore generally constructed, by three scaffolding poles tied together, over the hole (fig. 691.), from the centre of which a wheel and axle, or a pair of pulley blocks, are suspended, for the purpose of hauling up the rods, and from which hangs a forked hook (i). This forked hook is to be brought down under the shoulder, near the top of each rod, and made fast to it by passing a pin through two little holes in the claws. The rods are thus drawn up, about seven feet at a time, which is the usual distance between each joint, and at every haul a fork (k) is laid horizontally over the hole, with the shoulders of the lower rod resting between its claws, by which means the rods are prevented from sinking down into the hole again, while the upper length is unscrewed and removed. In attaching and detaching these lengths of rod, a wrench (l) is employed, by which they are turned round, and the screws forced up to their firm bearing.

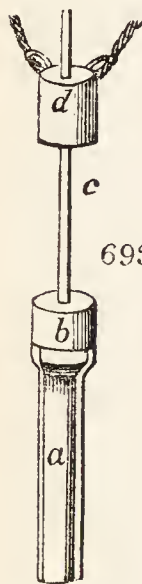
4490. The boring is sometimes performed for the first sixty or a hundred feet, by a chisel of two and a half inches wide, and cleared out by a gouge of two and a quarter diameter, and then the hole is widened by another tool (m). This is merely a chisel, four inches wide, but with a guide (n) put on at its lower part, for the purpose of keeping it in a perpendicular direction; the lower part is not intended to pick, but to pass down the hole previously made, while the sides of the chisel operate in enlarging the hole to four inches. The process, however, is generally performed at one operation, by a chisel four inches wide (b), and a gouge of three inches and three quarters (c).

4491. Placing and displacing the lengths of rod is done every time that the auger is required to be introduced or withdrawn; and it is obvious that this must of itself be extremely troublesome, independently of the labour of boring; but yet the operation proceeds, when no unpropitious circumstances attend it, with a facility almost incredible. Sometimes, however, rocks intercept the way, which require great labour to penetrate, but this is always effected by picking, which slowly pulverises the stone. The most

unpleasant circumstance attendant upon this business is, the occasional breaking of a rod in the hole, which sometimes creates a delay of many days, and an incalculable labour in drawing up the lower portion.

4492. *When the water is obtained* in such quantities and of such quality as may be required, the hole is dressed or finished by passing down it the diamond chisel (*o*): this is to make the side smooth previously to putting in the pipe. This chisel is attached to rods, and to the handle, as before described; and in its descent the workmen continually walk round, by which the hole is made smooth and cylindrical. In the progress of the boring, frequent veins of water are passed through; but as these are small streams, and perhaps impregnated with mineral substances, the operation is carried on until an aperture is made into a main spring, which will flow up to the surface of the earth. This must, of course, depend upon the level of its source, which, if in a neighbouring hill, will frequently cause the water to rise up and produce a continued fountain. But if the altitude of the distant spring happens to be below the level of the surface of the ground where the boring is effected, it sometimes happens that a well of considerable capacity is obliged to be dug down to that level, in order to form a reservoir, into which the water may flow, and from which it must be raised by a pump: while, in the former instance, a continued fountain may be obtained. Hence, it will always be a matter of doubt, in level countries, whether water can be procured which would flow near to or over the surface: if this cannot be effected, the process of boring will be of little or no advantage, except as an experiment to ascertain the fact.

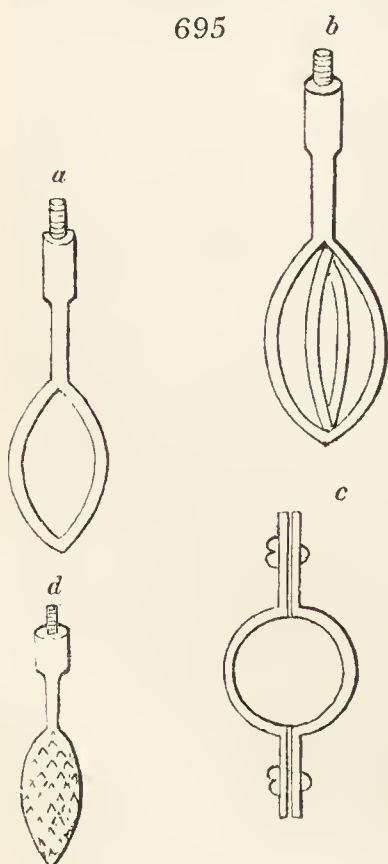
4493. *In order to keep the strata pure and uncontaminated* with mineral springs, the hole is cased for a considerable depth with a metallic pipe, about a quarter of an inch smaller than the bore. This is generally made of tin (though sometimes of copper or lead), in convenient lengths; and as each length is let down, it is held by a shoulder resting in a fork, while another length is soldered to it, by which means a continued pipe is carried through the bore as far as may be found necessary, to exclude land-springs, and to prevent loose earth or sand from falling in and choking the aperture. (*Newton's Journal*, vol. vi. p. 146.)



4494. *The manner of forcing down lengths of cast-iron pipe, after the bore is formed*, is this:—The pipe (*fig. 693. a*) has a socket in its upper end, in which a block of wood (*b*) is inserted. From this block a rod (*c*) extends upwards, upon which a weight (*d*) slides. To the weight (*d*) cords are attached, reaching to the top of the bore, where the workman alternately raises the weight and lets it fall, which, by striking upon the block (*b*), beats down the pipe by a succession of strokes; and when one length of pipe has by these means been forced down, another length is introduced into the socket of the former. Another tool for the same purpose (*fig. 694.*) is formed like an acorn, the point of the acorn strikes against the edge of the pipe, and by that means it is forced down the bore.

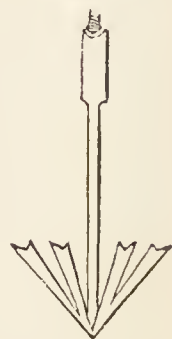


4495. *Wrought-iron, copper, tin, and lead pipes*, are occasionally used for lining the bore; and as these are subject to bends and bruises, it is necessary to introduce tools for the purpose of straightening their sides. One of these tools (*fig. 695. a*) is a bow, and is to be passed down the inside of the pipe, in order to press out any dents. Another tool for the same purpose (*b*) is a double bow, and may be turned round in the pipe for the purpose of straightening it all the way down. A pair of clams (*c*) is used for turning the pipe round in the hole while driving.



4496. *In raising pipes*, it is necessary to introduce a tool to the inside of the pipe, by which it will be held fast. The pine-apple stool for this purpose (*d*) has its surface cut like a rasp, which passes easily down into the pipe, but catches as it is drawn up, and by that means brings the pipe with it. There is a spear for the same purpose (*fig. 696*) which easily enters the pipe by springing; at the ends of its prongs there are forks which stick into the metal as it is drawn up, and thereby raise it.

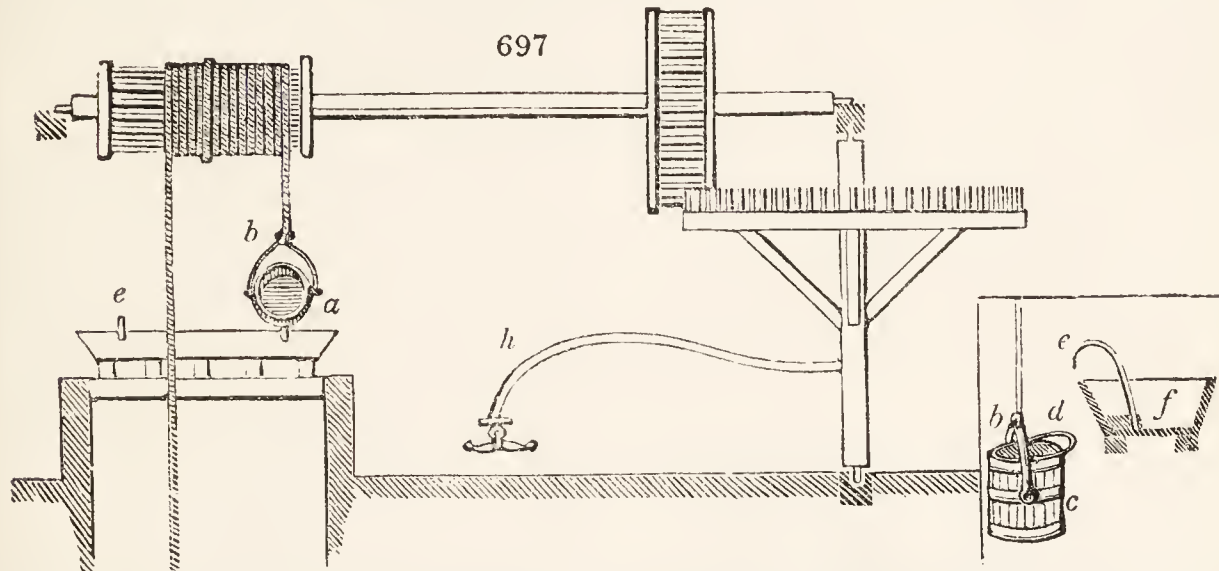
696



4497. *Mr. Goode suggests the employment of long baskets with valves opening upward in their bottoms*, for the purpose of drawing water from these wells when the water will not flow over the surface; also lift-pumps, with a succession of buckets, for the same purpose. (*Newton's Journal*, vol. viii. p. 249.)

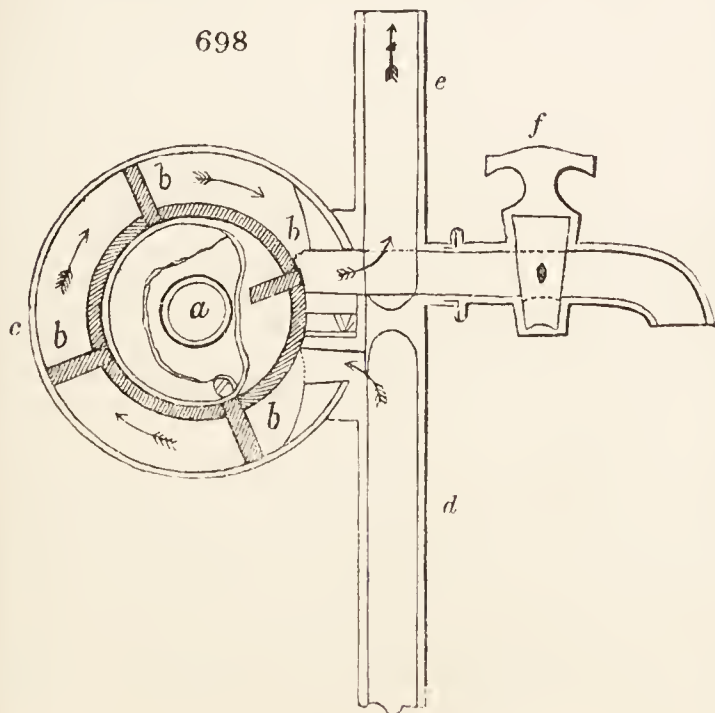
4498. *Mommon* has invented a new apparatus for guiding the operation of boring, which seems very ingenious; but we are not aware that it has yet been adopted in practice. Engravings, accompanied by a copious description, will be found in the *Mechanics' Magazine*, vol. iv. ; in which work are also various other articles on the same subject.

4499. *Of the various modes of raising water from deep wells*, the pump is the most convenient, and the lever and bucket the most simple. When a constant supply is wanted from a very deep well, machinery (fig. 697.) may be erected over it, and driven by an old horse or ass. While one bucket is filling, the



other is emptying. In order to effect the filling of the bucket, the handle (*b*), which is of iron, is attached by iron swivel rivets, on which it readily turns, below the centre of gravity of the bucket (*c*). In order that it may empty itself, a horizontal handle (*d*) is attached, which, when the filled bucket attains a certain height, is caught by a hook (*e*) fixed in the trough which conveys away the water raised (*f*). The horse or ass may be made to work in this machine without the attendance of a man, by the following training: — Attach a bell to the lever of draught (*h*); use eye-blinders to prevent the animal from seeing whether or not any one is in attendance, and from becoming giddy by going constantly round. Put the animal in motion, and the bell will not stop ringing till he stops. The moment he stops, and the bell ceases to ring, apply the whip severely. Continue to do this every time the animal stops, till the two hours' labour are completed; then unyoke and feed. After one or two hours, or whatever period may be deemed necessary for rest and refreshment, yoke again, and proceed as before. Go on in this way for two days, and the terror of receiving chastisement when the bell ceases to ring, will have frightened the animal into a habit of working two hours at a time without attendance. This mode is practised successfully in France, Italy, and Spain. (*Cours, &c. Art. Puit à Roue.*)

4500. *Pumps* are of various kinds, as the lifting-pump; the forcing-pump, for very deep wells; the suction pump; and the rotatory pump, a recent invention for such as do not exceed thirty-three feet in depth, and of which there are several varieties, but by far the best is that by *Siebc*. A good pump for urine pits or reservoirs, where the water is not to be raised above twenty-eight or thirty feet, is that of *Robertson Buchanan*, author of *A Treatise on Heating by Steam, &c.*; because this pump will raise drainings of dunghills, the contents of cesspools, privies, &c., or even water thickened by mud, sand, or gravel. "The points in which it differs from the common pump, and by which it excels it, are, that it discharges the water below the piston, and has its valves lying near each other. The advantages of this arrangement are: — that the sand or other matter which may be in the water is discharged without injuring the barrel or the piston-leathers; so that, besides avoiding unnecessary tear and wear, the power of the pump is preserved, and it is not apt to be diminished or destroyed in moments of extraordinary exertion, as is often the case with the common and chain pumps: that the valves are not confined to any particular dimensions, but may be made capable of discharging every thing that can rise in the suction-piece without danger of being choked; and that if, upon any occasion, there should happen to be an obstruction in the valves, they are both within the reach of a person's hand, and may be cleared at once, without the disjunction of any part of the pump. It is a simple and durable pump, and may be made either of metal or wood, at a moderate expense." Where clear water only is to be raised, *Aust's* (of Hoxton) *curvilinear* pump is preferable to the common sort. The advantages depend on the curvilinear form of the barrel, which allows,

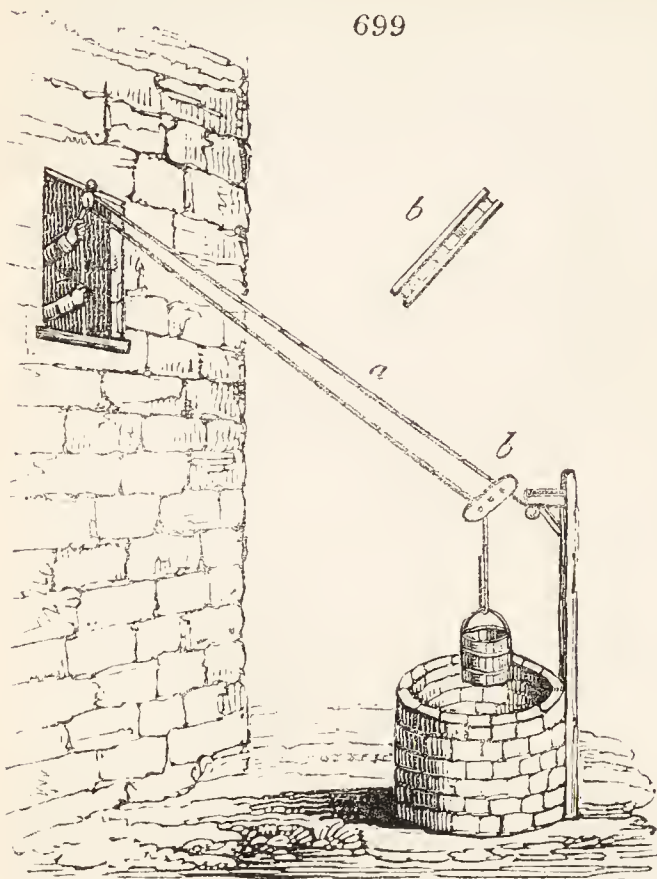


and indeed obliges, the rod, the handle, and the lever on which it works, to be all in one piece. Hence simplicity, cheapness, precision of action, more water discharged in proportion to the diameter of the barrel, and less frequent repairs. (*Repertory of Arts*, Jan. 1821.) *Perkins'* square-barrelled pump is a powerful engine (*London Journal, &c.*); but this and other contrivances for raising water, though promising advantages, cannot often be made available by the improver, from their not having come into general use.

4501. *Siebe's rotatory pump* (fig. 698.) appears to us by far the best of modern improvements on this machine. It is used for drawing, raising, and forcing all fluids and liquids, and may be worked by manual labour, steam, or any other power. By the rotation of a roller (*a*) having paddles or pistons (*b*) a vacuum is produced within the barrel (*c*), and in consequence the water flows up the rising trunk (*d*) through the space into the barrel, and as the paddles go round they force the water through an opening, which conducts it wherever it may be wanted, and by that means produces a continual stream without an air vessel. It is evident that this pump may, by an ascending tube (*e*), and a cock on the horizontal spout (*f*), be used as a common pump, or a forcing

pump at pleasure. (*Newton's Journal*, vol. ii. 2d series, p. 90.)

4502. An old but ingenious mode of raising water from a well to the upper part of a house (fig. 699.)



is sometimes adopted on the Continent. A post is fixed close to the well; this is connected with the opening in the upper part of the house, where the water is to be introduced, by a fixed cord (a). On this cord a wooden collar (b) is placed, and slides freely from one end to the other: the bucket rope is put through a hole in the collar, and over a pulley in the window in the upper part of the house, and thus the bucket is first raised perpendicularly from the water in the well till it comes in contact with the collar, when, the power being continued, the collar slides along the fixed rope till it reaches the operator at the window. (*Last. Col. de Machines, &c.*)

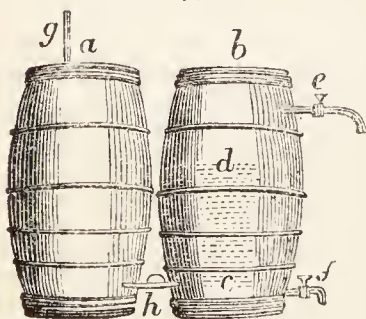
4503. *Artificial springs.* Marshal seeing the formation of natural springs, and observing the effect of subsoil drains, and being, at the same time, aware of an objection to roof water, which, though more wholesome, is seldom so well tasted as spring water; was led to the idea of forming artificial land springs, to supply farmsteads with water, in dry situations. He proposes arresting the rain-water that has filtered through the soil of a grass ground situated on the upper side of the buildings, in covered drains, clayed and dished at the bottom, and partially filled with pebbles or other open materials: thus conveying it into a well or cistern, in the

manner of roof water: and by this means uniting, it is probable, the palatableness of spring water with the wholesomeness of that which is collected immediately from the atmosphere.

4504. Water for common farm-yard and domestic purposes may be obtained in most situations, by collecting that which falls on the roofs of the farmery and dwelling-house. This is done by a system of gutters and pipes, which, for the farmery, may lead to a cistern or tank under ground; and for the family, that from the roof of the dwelling-house may be conducted to a tub. According to Waistell, a sufficient supply of water has been collected from the roof of a cottage to answer every purpose of the family during the driest season, by preserving the water so collected in a tank. The quantity of water that falls annually upon every hundred superficial feet, or square of building, is about 1400 gallons. Before using the water so collected, it should be filtered; and it seems very desirable that it should undergo this operation before it enters the tank.

4505. The operation of filtering may be performed in various ways: —

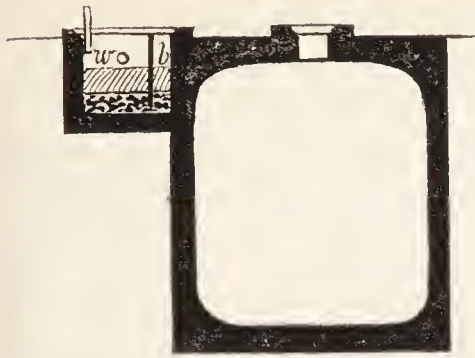
4506. A very simple mode is by having two casks two or three feet high, and of any convenient width (fig. 700.) One of these casks (a) may receive the water from the roof, or from any other supply; the other (b) should have a false bottom (c) perforated with holes and covered with flannel; on this flat bottomed equal quantities of sand and charcoal may be laid to the depth of twelve or fourteen inches, and covered with another false bottom similar to the first (d); the remainder of the cask will contain the filtered water, which may either be drawn off as wanted by a cock (e), or allowed to pass into an underground tank by the same means. The grosser impurities will always be deposited at the bottom of the filtering tank (b), and these may be drawn off at pleasure by a cock (f), placed immediately above the bottom of the barrel. The sand and charcoal may also be freed from any impurities which they may contract, by first allowing both barrels to be quite full, and then turning the bottom cock (f), in consequence of which the filtered water will descend through the filter and clear it. The advantage of having two barrels for the purpose of filtering the water from a roof is partly to retain a larger quantity,



on the supposition that there is not a reservoir or tank under ground, and partly to admit of supplying the first barrel, from ponds or other sources, in seasons when the roof is unproductive. Where the water is to be preserved in a tank under ground, only one barrel (b) is necessary, the pipe from the roof (g) proceeding, in that case, at once to the bottom of the filtering barrel, and entering where, in the case of two barrels, the junction-pipe (h) enters. In all cases of preserving water, whether filtered or unfiltered, it is of great importance to preserve a steady and a low temperature, and for this purpose an underground reservoir is highly desirable.

4507. The best form for a tank, according to Waistell, is a circular plan; the bottom in the form of a flat dome reversed, and the top also domical, with an opening left in the centre of sufficient size to admit a man to clean it out occasionally. "The top of this opening should be a little above the surface of the ground, and should be covered with an oak flap, with several holes bored in it for ventilation: or the cover may be an iron grating, horizontal, and a little elevated, or conical. These tanks may be constructed of various dimensions: the depth and width should be nearly equal; a hole should also be left for the service-pipe, or that which conveys the water into the tank, and also for the pipe for the pump, if the water be drawn out by that means. The water may be filtered previously to its entering the tank; the hole for the service-pipe ought, therefore, to be near the top, and on that side most convenient for the filtering chamber; this may be about four feet in diameter, and three feet deep: across this, about twelve

701



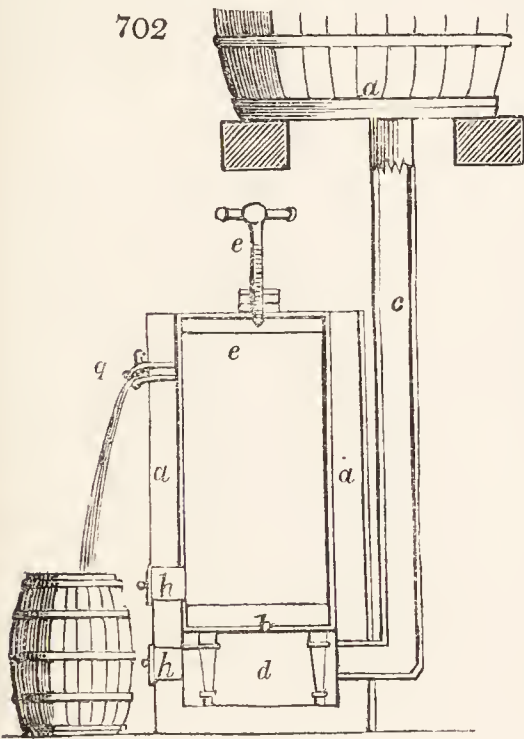
inches from the side next the tank (*fig. 701.*) a slate partition from the top to within about six inches from the bottom, should be fixed; at the bottom of the box should be put clean coarse sand or pounded charcoal, about a foot in thickness. The pipe or opening from the filter to the reservoir should be of ample dimensions, and be made at about eighteen or twenty inches from the bottom, in the small division or space behind the slate (*b*). Above this opening, and in any part most convenient (*w*), in the large division of the filter, should be an opening or drain to carry off the water when the tank is full. This filter should also have a cover, that it may be cleaned out, and fresh sand or other purifiers put in as often as may be found requisite. Of course the water as it comes from the roof is to be first conveyed into the large division of the filtering chamber, on the opposite side to the slate partition (*c*), and passing through the sand it rises in the small division purified, when it is fit to pass into the tank. If there are two or more of

these filtering chambers, or if they are of greater depth, the water may be passed through the greater quantity of sand, &c. in them, and be still more purified. Both the tanks and the filters should be water-tight: if constructed of brick, the inner course may be built with Roman cement, and afterwards the whole of the inside covered with a coat of about three quarters of an inch thick. Water, from drains formed in the ground for the purpose of collecting it for domestic purposes, may be purified, by passing it through a sand filter previously to its entering the tank or reservoir. Sponge and flannel may also be used as filters. In constructing tanks of the above description, care must be taken to have the earth to have the earth closely filled around the brick-work, and to allow sufficient time for the work to get properly settled, previously to admitting any great weight of water." (*Agricultural Buildings*, p. 15.)

4508. *Filtering water on a large scale* may be effected by emptying one pond into another on a lower level, through a conduit of any kind filled with gravel, sand, and charcoal.

4509. *A filtering apparatus for salt water* has been invented, but we are unable to say how far it has succeeded: it, at any rate, will succeed well with fresh water, and, we have no doubt, to a certain extent also with that of the sea. *Fig. 702.* *a a* is a cylindrical vessel of wood, or any other suitable material, which is lined on the inside with cement as far as the filterer extends; *b* is the bottom of the filterer, formed with a grating, which is supported by the rime of a stool; *c* is a pipe extending from the under part of a cask (*d*), containing the salt water, and which pipe opens to the lower part of the vessel *a a* below the filterer. Over the grating (*b*) there are placed several thicknesses of woven horse-hair, or a quantity of wool, and above this the vessel is filled with sand. On the top of the sand there is a plate (*e*) like a piston pressing upon the sand and keeping it compact, the plate being held down by a screw (*f*). The salt water thus delivered from the cask (*d*) by the pipe (*c*), fills the lower part of the vessel (*a*), and by the superincumbent pressure of the column descending from the cask, the water is forced upwards through the mass of sand, and runs off at the cock (*g*) in a purified state. There are man holes (*h, h*) for the purpose of getting access to the interior when it is required to remove the sand or other matters, and the internal surface of the filterer is rendered rough in order to prevent the water from sliding up the sides of the vessel, instead of passing through the sand. (*Newton's Journal*, vol. i. 2d series, p. 158.)

702



4510. *The distillation of palatable water at sea* has been effected by P. Nicole, of Dieppe, by simply causing the steam arising from boiling sea water in a still to pass through a stratum of coarsely powdered charcoal, in its way to the condenser, or worm-tub. (*Mechanics' Magazine*, vol. iv. p. 280.)

4511. *Water cisterns*, formed of blue slate, or Yorkshire paving-stones, are much better than those made of wood, and lined with lead. (*Waistell's Agricultural Buildings*, p. 15.)

4512. *Of waste lands*, many descriptions are best improved by planting, and therefore are to be considered as disposed of in that way in the laying out or arrangement of an estate; but there are others which may be more profitably occupied as farm-lands, and it is the preparing or bringing of these into a state of culture, which is the business of the present chapter. Such lands may be classed as mountainous or hilly grounds, rocky or stony surfaces, moors, bogs, or peat-mosses, marshes, woody wastes or wealds, warrens or downs, and sea-shores or beaches. In the improvement of these, many of the operations are such as are performed by temporary occupiers or farmers; but, as in this case such occupiers have always extraordinary encouragement from the landlords, either in the shape of a low rent, of money advanced, of long leases, or of all of these; we consider it preferable to treat of them as permanent, or fundamental improvements, than to consider them as parts of farm-culture. The delusive prospects of profit, from the improvement of wastes, held out by speculative men, have an unhappy tendency to produce disappointment in rash and sanguine adventurers, and ultimately to discourage such attempts as, with judicious attention to economy, would, in all probability, be attended with great success. Those who are conversant with the publications that have lately appeared on this subject must be aware with what caution the alleged results of most of these writers

CHAP. IV.

Improvement of Lands lying Waste, so as to fit them for Farm-Culture.

4512. *Of waste lands*, many descriptions are best improved by planting, and therefore are to be considered as disposed of in that way in the laying out or arrangement of an estate; but there are others which may be more profitably occupied as farm-lands, and it is the preparing or bringing of these into a state of culture, which is the business of the present chapter. Such lands may be classed as mountainous or hilly grounds, rocky or stony surfaces, moors, bogs, or peat-mosses, marshes, woody wastes or wealds, warrens or downs, and sea-shores or beaches. In the improvement of these, many of the operations are such as are performed by temporary occupiers or farmers; but, as in this case such occupiers have always extraordinary encouragement from the landlords, either in the shape of a low rent, of money advanced, of long leases, or of all of these; we consider it preferable to treat of them as permanent, or fundamental improvements, than to consider them as parts of farm-culture. The delusive prospects of profit, from the improvement of wastes, held out by speculative men, have an unhappy tendency to produce disappointment in rash and sanguine adventurers, and ultimately to discourage such attempts as, with judicious attention to economy, would, in all probability, be attended with great success. Those who are conversant with the publications that have lately appeared on this subject must be aware with what caution the alleged results of most of these writers

ought to be examined; and how different has been the experience of those who have ventured to put their schemes in practice, from what they had been led to anticipate. (*Gen. Rep. Scot.*)

SECT. I. *Mountainous and hilly Grounds and their Improvement.*

4513. *The upper parts of mountains* may be considered as among the least improvable parts of the earth's surface, from the impossibility of ever ameliorating their climate. "The highest peaks and ridges are mostly naked granite, slate, or volcanic productions. Their more elevated sides, and the tops of those of moderate height, are usually covered by a thin soil, producing a short dry herbage, which is frequently mixed with a dwarf, or stunted heath. Where the soil is not injured by moisture, these are best calculated for sheep. When the height of mountains exceed 800 feet of elevation above the level of the sea, unless covered either with natural woods or artificial plantations, they can only be profitably used in pasture." (*Code.*)

4514. *The hills, or lands less elevated than mountains*, have, in general, a deeper and moister soil, and produce a more luxuriant herbage, but of a coarse quality; hence they are better adapted for small hardy cattle. Though the summits of hills are generally unfit for raising grain, yet the plough is gradually ascending along their sloping sides, and within the last thirty years many thousand acres in such situations have been reclaimed in the United Kingdom.

4515. *Steep lands along the sides of rivers* and small streams are often inaccessible to the plough, and unfit for tillage. The more rugged of these are well calculated for woods or coppice; while those in more favourable situations and climates may be converted into orchards. (*Code of Agr.* 161.)

SECT. II. *Rocky or Stony Surfaces.*

4516. *Rocky and stony lands* are common in the valleys of a hilly or mountainous country, and sometimes, as in Aberdeenshire, they cover immense tracts of flat surface.

4517. *When rocks* protrude from the surface here and there in fragments of a few tons, and it is considered desirable to render the field or scene fit for aration, the only mode is to rend them asunder by gunpowder, and then carry off the fragments for walls, drains, roads, or buildings; or, if they are not wanted for these or any other purpose, to bury them so deep in the ground as to be out of the reach of the plough. But where rocks rise in considerable masses of several poles in diameter, it will generally be found preferable to enclose and plant them. Clefts and crevices are found in all rocks which have been long exposed to the air and weather, and in these may be inserted young plants, or seeds, or both. Such masses being enclosed by rough stone walls, formed from the more detached fragments, or from loose stones, will grow up and be at once highly ornamental and useful as shelter. It is true they will interrupt the progress of the plough in a straight line, but not more so than the rock if left in a state of nature. When a rocky surface is not intended to be ploughed, all that is necessary is to remove as many of the solitary rocks as possible, and either enclose and plant the rest, or cover them with earth.

4518. *The stones* which impede the improvement of land are either loose, thrown up when the land is trenched, or ploughed; or fixed in the earth, and not to be removed without much labour and expense.

4519. *Loose stones* may often be converted into use for the purpose of forming covered drains, of constructing walls or fences, or of making and repairing the roads on the farm or in the neighbourhood; and, on these accounts, are sometimes worth the trouble of collecting. They may be removed, with the least inconvenience, when the land is fallowed. Where loose stones are of a moderate size, they are sometimes found advantageous rather than detrimental, as in the stone-brash soils of Somersetshire and other districts. They prevent evaporation, and thus preserve moisture in the soil. Hence the old remark, that farmers have been induced to bring back again to their corn-fields those very stones they have been induced to carry off. (*Code.*)

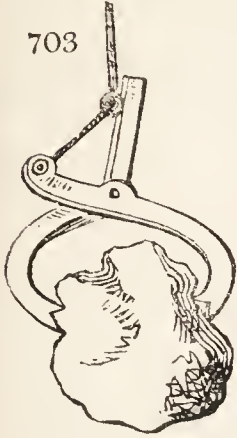
4520. *Where stones are large* and fixed in the earth, if they appear above the surface, they should be removed before the ploughing of the waste commences; but where they are concealed under the surface, various modes to get rid of them have been adopted. In some parts of Yorkshire, the whole surface is gone over with sharp prongs, which, at the distance of every twelve or fourteen inches, are thrust into the ground to the depth of about a foot, to ascertain where stones are to be met with. The spot is marked by a twig, and the stones are removed before the land is ploughed. Sometimes the plough is used without such previous examination, and the place marked where stones are encountered, that they may be taken away; and sometimes, in order to discover and remove such stones, the land is trenched by the spade (*Communications to the Board of Agriculture*, vol. ii. p. 253.)

4521. *Stones above the surface* may be avoided by the ploughman, though not without loss of ground; but stones under the surface are often not discovered till the plough is drawn against them, and perhaps broken, by which a day's work is sometimes lost. A wooden bolt, however, to unite the horse-trees to the chain of the plough, may prevent mischief by giving way. Clearing the ground from stones not only prevents such mischiefs, but is attended with actual profit. When removed, they may be used for various purposes, and are often less expensive than if dug, or purchased at a quarry. The soil round a large stone is likewise, in general, the best in the field, and is bought at a low rate by the expense of taking out the stone, as the plough has thus access to all the land around it. In stony land the plough must proceed slowly, and cannot perform half so much work as it ought to do; but, after such impediments have been removed, the field may be ploughed with the usual facility and cheapness, and in a much more perfect manner. It frequently happens, that when working stony land, more expense is incurred in one season by the breaking of ploughs, besides the injury done to the horses and harness, than would cure the evil. (*Gen. Rep. of Scot.* vol. iii. p. 256; *Kaimes's Gent. Farmer*, p. 58.)

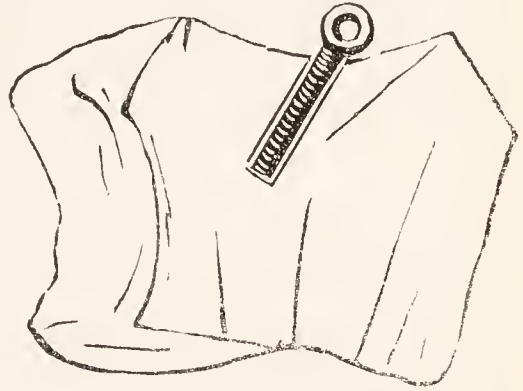
4522. There are various modes of getting rid of stones. These are generally of such a size as to admit of being conveyed away in carts or other vehicles calculated for the purpose. Some ingenious artificers have constructed machines for raising them, when large. On some occasions, pits have been dug close to large stones, and the latter have

704

703



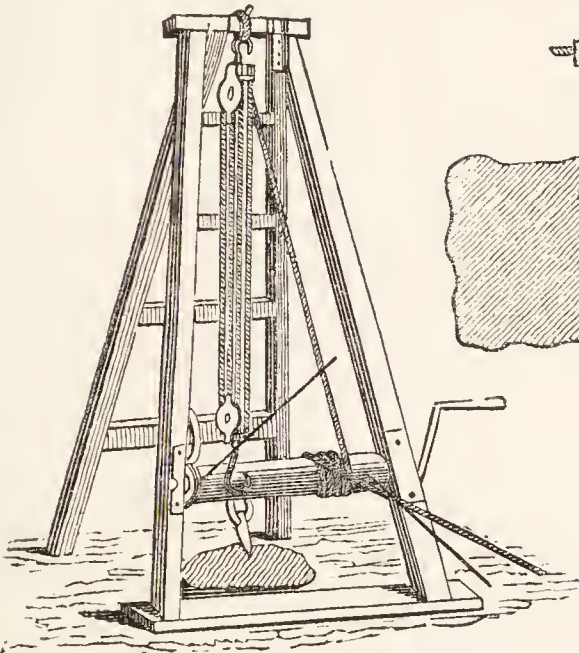
been turned into the former, at such a depth as to lie out of the reach of the plough: but it is frequently necessary to reduce their size by the force of gunpowder before they can be removed. Loose stones are commonly moved by levers, and rolled on a sledge; but sometimes they are raised by a block and tackle attached to a triangle with a pair of callipers to hold the stone (fig. 703.) The stone may also



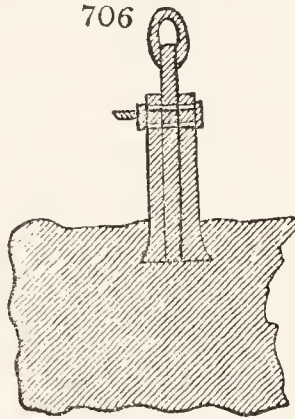
obliquely and then inserting an iron bolt with an eye (fig. 704.), which, though loose, will yet serve to raise the stone in a perpendicular direction.

4523. Richardson's machine for raising large stones (fig. 705.)

705



706

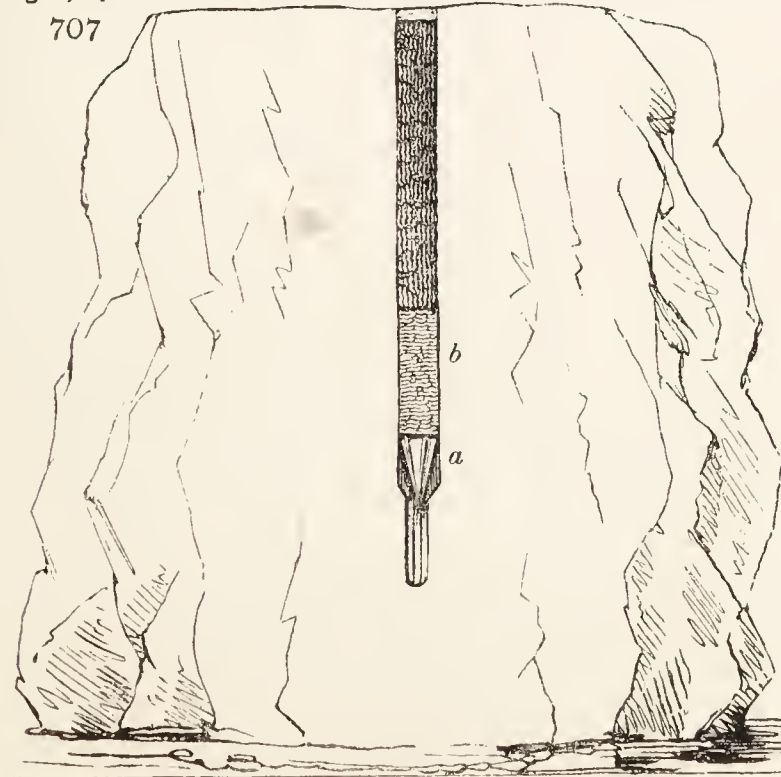


consists of a frame-work supporting a five-fold tackle, with blocks ten inches in diameter, and a roller seven inches in diameter turned by two long iron levers. A hole is made in the stone to be raised by means of the tool well known to masons as a jumper; in this hole a simple plug may be driven tightly; or a compound plug (fig. 706.) may be introduced; or, what is simplest, the hole may be made obliquely. (Smith's Compendium of Practical Inventions.)

4524. The mode of bursting or rending rocks or stones by gunpowder is a simple though dangerous operation. When a hole is to be made in a rock for the purpose of blasting with gunpowder, the prudent work man considers the nature of the rock, and the inclination or dip of the strata, if it is not a detached fragment, and from these determines the calibre, and the depth and direction of the bore or recipient for the gunpowder. According to circumstances, the diameter of the hole varies from half an inch to two inches and a half, the depth from a few inches to many feet, and the direction varies to all the angles from the perpendicular to the horizontal. The implements for the performance of this operation are rude, and so extremely simple

and familiar as hardly to require description; and the whole operation of boring and blasting rocks is so easily performed, that, in the space of a few weeks, an intelligent labourer may become an expert quarrier. A writer in the *Mechanics' Magazine* has proposed to increase the effect of the gunpowder, by widening the lower extremity of the bore, and this he thinks may be effected, after the bore is made of the proper length, by introducing an instrument with a jointed extremity which would work obliquely.

707



4525. The operation of ramming frequently gives rise to accidents; but a recent improvement, that of using a wadding of loose sand, or of any earthy matter in a dry state, answers all the purposes of the firmest ramming or wadding. It has been used for upwards of ten years at Lord Elgin's extensive mining operations at Charlestown in Fifeshire, and also in removing immense bodies of rock from the Calton hill at Edinburgh, by Stevenson, an eminent engineer, whose article on the subject of blasting, in the *Sup. to the Encyc. Brit.* deserves the attention of such as use the process in working quarries or clearing rocky or stony grounds.

4526. Dr. Dyce of Aberdeen has communicated to Dr. Brewster's *Journal* an account of a cheap and effectual method of blasting granite rock, which deserves the particular attention of the owners and workers of quarries. It is beautifully scientific, and may be summed up under the three following heads: viz. 1. To ignite the gunpowder at the bottom of the charge, by means of sulphuric acid, charcoal, and sulphur. 2. To take advantage of the propelling power

of gunpowder, as is done with a cannon ball, only, instead of a spherical ball, to employ one of a conical form (fig. 707.), by which the full effect of the wedge is given in every direction at the lower part of the charge, but particularly downwards. 3. And, in the last place, to add to the effect of the whole, to insure a fourth part of the depth of the bore at the bottom (*b*) to be free from the gunpowder; so that, when inflammation ensues, a red heat may be communicated to the air in the lower chamber, whereby it will be expanded to such a degree as to have the power of at least one hundred times the atmospheric pressure, and thereby give this additional momentum to the explosive power of the gunpowder. (*Dr. Brewster's Edin. Journ.* Oct. 1826. p. 343., and *Gard. Mag.* vol. ii. p. 467.)

4527. *The Assamese* close the mouth of the hole by driving in with a mallet a stout wooden plug some inches in length, through which a touch-hole is bored. Between the powder and the lower part of the plug, an interval of several inches is left. The communication is perfected by means of a tin tube filled with powder, and passing through the centre of the plug. (*Monthly Magazine.*)

SECT. III. Improving Woody Wastes or Wealds.

4528. *With surfaces partially covered with bushes and stumps of trees, ferns, &c.,* the obvious improvement is to grub them up, and subject the land to cultivation according to its nature.

4529. *The growth of large trees* is a sign that the soil is naturally fertile. It must also have been enriched by the quantity of leaves which in the course of ages have fallen and rotted upon the surface. Such are the beneficial effects of this process, that after the trees have been cut down, the soil has often been kept under crops of grain for a number of years without interruption or any addition of manure: but land thus treated ultimately becomes so much reduced by great exhaustion, that it will not bear a crop worth the expense of seed and labour. (*Comm. to the Board of Agr.*, vol. ii. p. 257.) It is evident, however, that this deterioration entirely proceeds from the improvident management previously adopted. In reclaiming such wastes, the branches of the felled trees, are generally collected and burnt; and the ashes, either in whole or in part, are spread on the ground, by which the fertility of the soil is excited. Indeed, where there is no demand for timber on the spot, nor the means of conveyance to any advantageous market, the whole wood is burnt, and the ashes applied as manure.

4530. *Much coppice land has been grubbed up* in various parts of England, and brought into tillage. Sometimes woods are grubbed for pasture merely. In that case the ground should be as little broken as possible, because the surface of the land, owing to the dead wood and leaves rotting time out of mind upon it, is much better than the mould below. It soon gets into good pasture as grass land, without the sowing of any seed. (*Comm. to the Board of Agr.* vol. iv. p. 42.) But by far the most eligible mode of converting woodland into arable is merely to cut down the trees, and to leave the land in a state of grass until the roots have decayed, cutting down with the scythe from time to time any young shoots that may arise. The roots in this way, instead of being a cause of anxiety and expense, as they generally are, become a source of improvement; and a grassy surface is prepared for the operation of sod burning. (*Marshal's Yorkshire*, vol. i. p. 316.)

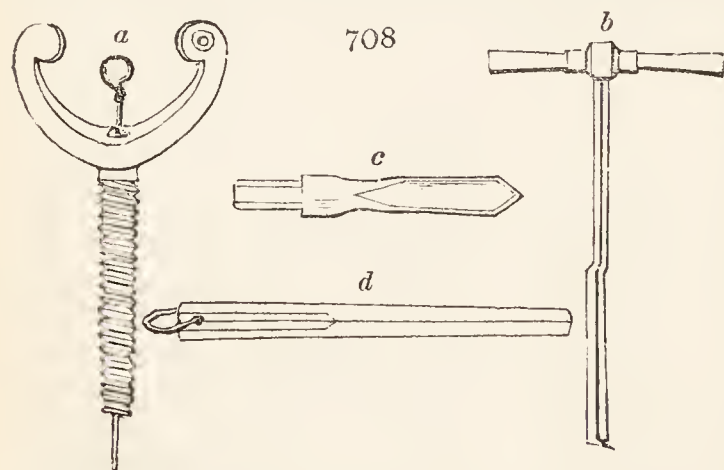
4531. *Natural woods and plantations* have been successfully grubbed up in Scotland. In the lower Torwood in Stirlingshire, many acres of natural coppice were cleared; and the land is now become as valuable as any in the neighbourhood. (*Stirlingshire Report*, p. 213.) On the banks of the Clyde and the Avon, coppices have been cut down, and the land, after being drained, cultivated, and manured, has been converted into productive orchards. In Perthshire, also, several thousand acres of plantations have been rooted out, the soil, subjected to the plough, converted into good arable land, and profitably employed in tillage. (*Perthshire Report*, p. 329.)

4532. *For pulling up or rending asunder the roots of large trees*, various machines and contrivances have been invented. Clearing away the earth and splitting with wedges constitute the usual mode; but blasting is also, as in the case of rocks and stones, occasionally resorted to. For this purpose a new instrument,

called the *blasting-screw* (fig. 708.), has been lately applied with considerable success to the rending or splitting of large trees and logs of timber. It consists of a screw (*a*), an auger (*b, c*), and charging-piece (*d*). The screw is wrought into an auger-hole, bored in the centre of the timber: here the charge of powder is inserted, and the orifice of the hole in the log is then shut up or closed with the screw, when a match or piece of cord, prepared with saltpetre, is introduced into a small hole (*a*), left in the screw for this purpose, by which the powder is ignited. The application of this screw to the purposes of blasting is not very obviously necessary; because, from what we have seen (4525.), it would appear that the auger-hole, being charged with powder and sand, would answer every purpose. One great objection to the process of blasting applied to the rending of timber is, the irregular and

uncertain direction of the fracture, by which great waste is sometimes occasioned. It may, however, be necessary to resort to this mode of breaking up large trees, when cut down and left in inaccessible situations, where a great force of men and implements cannot easily be procured or applied; and certainly it is one of the most effectual modes of tearing their stools or roots in pieces. (*Sup. Encyc. Brit.* art. *Blasting.*)

4533. *Land covered with furze, broom, and other shrubs*, is generally well adapted for cultivation. The furze, or whin (*Ulex europæa*), will grow in a dense clay soil; and where found in a thriving state, every species of grain, roots, and grasses, may be cultivated with advantage. The broom, on the other hand, prefers a dry, gravelly, or sandy soil, such as is adapted for the culture of turnips. A large proportion of the arable land, in the richest districts of England and Scotland, was originally covered by these two plants; and vast tracts still remain in that state, which might be profitably brought



under cultivation. For this purpose, the shrubs ought to be cut down, the ground trenched, or the plants rooted out by a strong plough, drawn by four or six horses, and the roots and shrubs (if not wanted for other purposes), burnt in heaps, and the ashes spread equally over the surface. (*Com. to the Board of Agr.* vol. ii. p. 260.) In many places, shrubs and brushwood may be sold for more than the expense of rooting them out. When coal is not abundant, and limestone or chalk can be had, the furze should be employed in burning the lime used in carrying on the improvement. (*Oxfordshire Report*, p. 232.) It requires constant attention, however, to prevent such plants from again getting possession of the ground, when restored to pasture. This can best be effected, by ploughing up the land occasionally, taking a few crops of potatoes, turnips, or tares in rows, and restoring it to be depastured by sheep. In moist weather, also, the young plants should be pulled up and destroyed. (*Code.*)

4534. *Fern* (*Ptèris* and *Osmúnda*) is a very troublesome weed to extirpate, as, in many soils, it sends down its roots into the under stratum, beyond the reach of the deepest ploughing; but it is a sign of the goodness of any soil where it grows to a large size. June and July are the best seasons for destroying it; the plants are then full of sap, and should be frequently cut. They are not, however, easily subdued, often appearing after a rotation of seven years, including a fallow, and sometimes requiring another rotation, and repeated cutting, before their final disappearance can be effected. Lime in its caustic state is peculiarly hostile to fern; at the same time, this weed can hardly be completely eradicated but by frequent cultivation, and by green crops assisted by the hoe. (*Oxfordshire Report*, pp. 234. 240.)

4535. *The heath* (*Èrica*) is a hardy plant, palatable and nutritious to sheep; and under its protection coarse grasses are often produced. When young, or in flower, it may be cut and converted into an inferior species of winter provision for stock; but where it can be obtained, it is desirable to have grass in its stead. For this purpose, the land may in some cases be flooded, and in others the heath may be burned, and the land kept free from stock for eighteen months; in consequence of either of these modes, many new grasses will spring up, from the destruction of the heath, and the enriching quality of the deposit from the water or the ashes. The improvement is very great; more especially if the land be drained, and lime or compost applied. (*Gen. Rep. of Scot.* vol. ii. p. 359.) But if the land be too soon depastured, the grasses being weak and tender, the sheep or cattle will pull them up with their roots, and will materially injure the pasture. (*Statistical Account of Scotland*, vol. iv. p. 465.) Where it is proposed to cultivate the land for arable crops, the lime applied should be in a finely powdered state, highly caustic, and as equally spread as possible. (*Com. to the B. of Agr.* vol. ii. p. 264.) Lime in a caustic state is an excellent top dressing for heath. It is astonishing to see white clover spring up, after lime has been some time applied, on spots where not a green leaf could be detected before.

4536. *Paring and burning* is a speedy and effectual mode of bringing a surface covered with coarse herbage into a state of culture. Some have recommended making a compost of the pared surface, with lime; or building folds or earthen walls of the sods, which, by the action of the atmosphere, become friable and fertile; but these processes are slower and not so effectual as paring and burning. In coarse rough pastures, ant-hills frequently abound, which are effectually destroyed by paring and burning. (*Code.*)

SECT. IV. *Moors and their Improvements.*

4537. *Moorlands* are of various descriptions. Sometimes they are in low and mild situations, where the upper soil is thin or scantily supplied with vegetable mould, and where the bottom or under-stratum is impervious and barren: these, in general, may be reclaimed with more or less advantage, according to the proximity of manure or markets, and of other means of improvement. Sometimes, on the contrary, they are in situations much elevated above the level of the sea; where the surface is covered with heath and other coarse plants; and frequently encumbered with stones: such moors are seldom worth the expense of cultivation, and from their height are only calculated for woods or pasturage.

4538. *Moors not placed in high or bleak situations*, where the surface is close-swarded, or covered with plants, and where the subsoil is naturally either not altogether wet, or capable of being made sufficiently dry at a moderate expense, may not only be reclaimed, but can often be highly improved by the common operations of farm culture, by paring and burning, by fallow and liming, or by trenching or deep ploughing.

4539. *Vast improvements on different sorts of moory lands have been made in Yorkshire* where there are immense tracts of moors. It is stated in *The Agricultural Report of the North Riding of Yorkshire*, that an improvement was made upon Lockton Moor, on a quantity of land of about seventy acres, which would not let for more than 1s. per acre before it was enclosed. Of this forty-eight acres were pared and burnt, and sown with rape, except about an acre sown with rye; the produce about sixty quarters. The rye grew very strong, and in height not less than six feet, and was sold, while standing, for five guineas the acre. The land was only once ploughed, otherwise the crop of rape would probably have been much better. One hundred and twenty chaldrons (each thirty-two bushels) of lime were ploughed into the

field; which, for want of more frequent ploughing, was probably not of the service it otherwise might have been. Part of the land was afterwards sown down with oats and grass seeds; the former of which afforded but a moderate crop, the latter a very good one, and has since produced two loads, 120 stones each, per acre. The seeds sown were rye-grass, rib-grass, white clover, and trefoil; of these, the first succeeded amazingly, the others not so well; potatoes thrive very well; turnips not equal to them. A farm-house has been built upon it, which now, along with five acres more of the same kind of land, is let on lease at thirty pounds per annum. The soil consisted, in general, of benty peat, upon red gritstone, with a mixture of clay upon limestone; this last is, in some places, at a considerable depth, in others, sufficiently near the surface for lime to be burnt on the premises.

4540. *Finlayson's rid-plough* (§ 2605.) has been found a valuable implement in breaking up heath and moorlands, in Scotland.

SECT. V. *Peat Mosses, Bogs, and Morasses, and their Improvement.*

4541. *Mossy and boggy surfaces* occupy a very considerable portion of the British Isles. In Ireland alone there are of flat red bog, capable of being converted to the general purposes of agriculture, 1,576,000 acres; and of peat soil, covering mountains, capable of being improved for pasture, or beneficially applied to the purposes of plantation, 1,255,000 acres, making together nearly three millions of acres. Mossy lands, whether on mountains or plains, are of two kinds: the one black and solid; the other spongy, containing a great quantity of water, with a proportion of fibrous materials.

4542. *Black mosses*, though formerly considered irreclaimable, are now found capable of great melioration. By cultivation, they may be completely changed in their quality and appearance; and, from a peaty, become a soft vegetable earth of great fertility. They may be converted into pasture; or, after being thoroughly drained, thriving plantations may be raised upon them; or, under judicious management, they will produce crops of grain and roots; or, they may be formed into meadow-land of considerable value.

4543. *Flow, fluid, or spongy mosses*, abound in various parts of the British Isles. Such mosses are sometimes from ten to twenty feet deep, and even more, but the average may be stated at from four to eight. In high situations, their improvement is attended with so much expense, and the returns are so scanty, that it is advisable to leave them in their original state; but where advantageously situated, it is now proved that they may be profitably converted into arable land, or valuable meadow. If they are not too high above the level of the sea, arable crops may be successfully cultivated. Potatoes, and other green crops, where manure can be obtained, may likewise be raised on them with advantage.

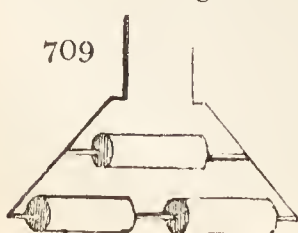
4544. *Peat* is certainly a production capable of administering to the support of many valuable kinds of plants: but to effect this purpose, it must be reduced to such a state, either by the application of fire, or the influence of putrefaction, as may prepare it for their nourishment. In either of these ways, peat may be changed into a soil fit for the production of grass, of herbs, or of roots. The application of a proper quantity of lime, chalk, or marl, prepares it equally well for the production of corn. (*Code*.)

4545. *The fundamental improvement* of all peat soils is drainage, which alone will in a few years change a boggy to a grassy surface. After being drained, the surface may be covered with earthy materials, pared and burned, fallowed, dug, trenched, or rolled. The celebrated Duke of Bridgewater covered a part of Chatmoss with the refuse of coal-pits, a mixture of earths and stones of different qualities and sizes, which were brought in barges out of the interior of a mountain; and, by compressing the surface, enabled it to bear pasturing stock. Its fertility was promoted by the vegetable mould of the morass, which presently rose and mixed with the heavier materials which were spread upon it. (*Marshal on Landed Property*, p. 46.)

4546. *The fenny grounds* of Huntingdonshire are in some cases improved by applying marl to the surface. Where that substance is mixed with the fen soil, the finer grasses flourish beyond what they do on the fen soil unmixed; and when the mixed soil is ploughed, and sown with any sort of grain, the calcareous earth renders the crops less apt to fall down, the produce is greater, and the grain of better quality than on any other part of the land. (*Huntingdonshire Report*, p. 301.)

4547. *Covering the surface of peat bogs with earth* has been practised in several parts of Scotland. Clay, sand, gravel, shells, and sea ooze, two or three inches thick, or more, have been used; and land, originally of no value, has thus been rendered worth from 2*l.* to 3*l.* and even 4*l.* per acre. The horses upon this land must either be equipped with wooden clogs, or the work performed in frosty weather, when the surface of the moss is hard. Coarse obdurate clay (provincially *ill*) is peculiarly calculated for this process; as, when it is blended with peat and some calcareous matter, it contains all the properties of a fertile soil. (*Clydesdale Report*, p. 150, note.) This is certainly an expensive method of improving land, unless the substance to be laid upon it is within 500 yards' distance; but where it can properly be done, the moss thus obtains solidity, and after it has been supplied with calcareous earth, it may be cultivated, like other soils, in a rotation of white and green crops. In the neighbourhood of populous towns, where the rent of land is high, the covering substance may be conveyed from a greater distance than 500 yards. (*Code*.)

4548. *Rolling peaty surfaces* has been found to improve them. The greatest defect of soft soils is, that the drought easily penetrates them, and they become too open. The roller is an antidote to that evil, and the expense is the only thing that ought to set bounds to the practice of this operation. It also tends to destroy those worms, grubs, and insects, with which light and fenny land is apt to be infested. The roller for such soils ought not to be heavy, nor of a narrow diameter. If it is weighty, and the diameter small,



it sinks too much where the pressure falls, which causes the soft moss to rise before and behind the roller, and thus, instead of consolidating, it rends the soil. A gentle pressure consolidates moss, but too much weight has a contrary effect. A roller for moss ought therefore to be formed of wood, the cylinder about four feet diameter, and mounted to be drawn by two or three men. Three small rollers working in one frame, (*fig. 709*), have sometimes been so drawn. When horses are employed, they ought to have clogs or pattens, if likely to sink. The oftener the rolling is performed, on spongy soils as long as the crops of corn or grass will admit of it, the better, and the more certain is the result.

4549. *An extensive tract of moss in the county of Lancaster* has been recently improved by the celebrated Roscoe of Liverpool, in a very spirited and skilful manner. Chatmoss in that county is well known; its length is about six miles, its greatest breadth about three miles, and its depth may be estimated from ten to upwards of thirty feet. It is entirely composed of the substance well known by the name of peat, being an aggregate of vegetable matter, disorganised and inert, but preserved by certain causes from putrefaction. On the surface it is light and fibrous, but becomes more dense below. On cutting to a considerable depth, it is found to be black, compact, and heavy, and in many respects resembling coal. There is not throughout the whole moss the least intermixture of sand, gravel, or other material, the entire substance being a pure vegetable. About 1796 or 1797, Roscoe began to improve Trafford moss, a tract of three hundred acres, lying two miles east of Chatmoss; and his operations on it seem to have been so successful as to encourage him to proceed with Chatmoss. In the improvement of the latter, he found it unnecessary to incur so heavy an expense for drainage as he had done in the former. From observing that where the moss had been dug for peat, the water had drawn towards it from a distance of fifty to a hundred yards, he conceived that if each drain had to draw the water only twenty-five yards, they would, within a reasonable time, undoubtedly answer the purpose. The whole of the moss was therefore laid out on the following plan:—

4550. *A main road*, Roscoe states, “was first carried nearly from east to west, through the whole extent of my portion of the moss. This road is about three miles long and thirty-six feet wide; it is bounded on each side by a main drain, seven feet wide and six feet deep, from which the water is conveyed, by a considerable fall, to the river. From these two main drains, other drains diverge, at fifty yards’ distance from each other, and extend from each side of the road to the utmost limits of the moss. Thus, each field contains fifty yards in front to the road, and is of an indefinite length, according as the boundary of the moss varies. These field-drains are four feet wide at the top, one foot at the bottom, and four feet and a half deep. They are kept carefully open, and, as far as my experience hitherto goes, I believe they will sufficiently drain the moss, without having recourse to underdraining, which I have never made use of at Chatmoss, except in a very few instances, when, from the lowness of the surface, the water could not readily be gotten off without open channels, which might obstruct the plough.”

4551. *The cultivation of the moss* then proceeds in the following manner:—“After setting fire to the heath and herbage on the moss, and burning it down as far as practicable, I plough a thin sod or furrow, with a very sharp horse-plough, which I burn in small heaps and dissipate: considering it of little use but to destroy the tough sods of the *Eriophorum*, *Nardus*

stricta, and other plants, whose matted roots are almost imperishable. The moss being thus brought to a tolerably dry and level surface, I then plough it in a regular furrow six inches deep, and as soon as possible after it is thus turned up, I set upon it the necessary quantity of marl, not less than two hundred cubic yards to the acre. As the marl begins to crumble and fall with the sun or frost, it is spread over the land with considerable exactness, after which I put in a crop as early as possible, sometimes by the plough, and at others with the horse-scuffle or scarifier, according to the nature of the crop, adding, for the first crop, a quantity of manure, which I bring down the navigable river Irwell, to the borders of the moss, setting on about twenty tons to the acre. Moss land thus treated may not only be advantageously cropped *the first year* with green crops, as potatoes, turnips, &c. but with any kind of grain; and as wheat has, of late, paid better to the farmer than any other, I have hitherto chiefly relied upon it, as my first crop, for reimbursing the expense.”

4552. *The expense of the several ploughings*, with the burning, sowing, and harrowing, and of the marl and manure, but exclusive of the seed, and also of the previous drainage and general charges, amounts to 1*l.* 5*s.* per acre; and in 1812, on one piece of land thus improved, Roscoe had twenty bushels of wheat, then worth a guinea per bushel, and on another piece eighteen bushels; but these were the best crops upon the moss. “Both lime and marl are generally to be found within a reasonable distance; and the preference given to either of them will much depend upon the facility of obtaining it. The quantity of lime necessary for the purpose is so small, in proportion to that of marl, that, where the distance is great, and the carriage high, it is more advisable to make use of it; but where marl is upon the spot, or can be obtained in sufficient quantity at a reasonable expense, it appears to be preferable.” Roscoe is thoroughly convinced, after a great many different trials, that all temporizing expedients are fallacious; and “that the best method of improving moss land is *by the application of a calcareous substance, in sufficient quantity to convert the moss into a soil, and by the occasional use of animal or other extraneous manures*, such as the course of cultivation, and the nature of the crops, may be found to require.”

4553. *Roscoe’s contrivance for conveying on the marl* seems peculiar. It would not be practicable, he observes, to effect the marling at so cheap a rate, (1*l.* per acre,) were it not for the assistance of an iron road or railway, laid upon boards or sleepers, and moveable at pleasure. Along this road the marl is conveyed in waggons with small iron wheels, each drawn by one man. These waggons, by taking out a pin, turn their lading out on either side; they carry about 15 cwt. each, being as much as could heretofore be conveyed over the moss by a cart with a driver and two horses.

4554. *An anomalous mode of treating peat bogs* was invented and practised by the late Lord Kaimes, which may be applicable in a few cases. This singular mode can be adopted only where there is a command of water, and where the subjacent clay is of a most fertile quality, or consists of alluvial soil. A stream of water is brought into the moss, into which the spongy upper stratum is first thrown, and afterwards the heavier moss, in small quantities at a time; the whole is then conveyed by the stream into the neighbouring river, and thence to the sea. The moss thus got rid of, in the instance of Blair Drummond, in Perthshire, was, on an average, about seven feet deep. Much ingenuity was displayed in constructing the machinery, to supply water for removing the moss, previously to the improvement of the rich soil below. It required both the genius and the perseverance of Lord Kaimes to complete this scheme; but by this singular mode of improvement, about 1000 English acres have been already cleared, a population of above 900 inhabitants furnished with the means of subsistence, and an extensive district, where only snipes and moorfowl were formerly maintained, is now converted, *as if by magic*, into a rich and fertile *carse*, or tract of alluvial soil. (*Code.*) In *The General Report of Scotland*, Appendix, vol. ii. p. 38., and at p. 326 of this work, will be found a detailed account of this improvement.

4555. *Moss has been converted into manure* by fermentation with stable dung, and with this article joined with whale oil. In the *Highland Soc. Trans.*, vol. vii., an account is given (p. 147.) of several experiments of this kind by W. Bell, Esq.:—A layer of moss a foot thick was formed after the material was tolerably dry, in the month of June; above this a layer of stable dung was placed, at least twice the thickness of that of moss; next followed another layer of moss thicker than the first; on this last layer a ton of coarse whale oil was poured, and the whole was completely covered up with moss. In ten days the whole mass came freely into heat; in about eight weeks it was turned, and continued to ferment freely; in a few weeks afterwards the whole mass resembled black garden mould. Out of twenty-five cubic yards of stable dung, and one ton of oil, two hundred and sixty cubic yards of compost were produced.

4556. *Peat may be charred* and rendered fit to be used like charcoal in cookery and other domestic purposes, in the same way as wood or coal is charred, and in much less time. For ordinary purposes, it is charred by some families on the kitchen fire, thus:—Take a dozen or fifteen peats, and put them upon the top of the kitchen fire, upon edge: they will soon draw up the coal fire, and become red in a short time: after being turned about once or twice, and done with smoking, they are charred, and may be removed to the stoves: if more char is wanted, put on another supply of peat, as before mentioned. By following this plan, you keep up the kitchen fire, and have at the same time, with very little trouble, a supply of the best charred peat, perfectly free of smoke; and the vapour is by no means so noxious as charcoal made from wood. Peats charred in this way may be used in a chafer, in any room, or even in a nursery, without any danger arising from the vapour. It would also be found very fit for the warming of beds; and much better than live coals, which are in general used full of sulphur, and smell all over the house. (*Farm. Mag.* vol. xvii.)

SECT. VI. *Marshes and their Improvement.*

4557. *A tract of land on the borders of the sea or of a large river* is called a marsh: it differs from the fen, bog, and morass, in consisting of a firmer and better soil, and in being occasionally flooded. Marshes are generally divided into fresh-water marshes and salt-water marshes; the latter sometimes called saltings or iugs: fresh-water marshes differ from meadows, in being generally soaked with water from the sub-soils or springs.

4558. *Fresh-water marshes* are often found interspersed with arable land, where springs rise, and redundant water has not been carried off; and may be improved by a course of ditching, draining, and ploughing. Where large inland marshes are almost constantly

covered with water, or the soil is extremely wet, they may be drained, as large districts in the fens of Lincolnshire have been, and made highly valuable. The object, in that case, is, by embankments, draining, and other means of improvement, to convert these marshes into pasture or meadow, or even arable lands; and where such improvements cannot be accomplished, the most useful woody aquatics, as willows, osiers, &c., may be grown with advantage.

4559. *Romney marsh* is one of the most extensive and fertile fresh-water marshes in Britain. It contains nearly 24,000 acres; besides which Walland marsh and Dingle marsh, which are comprised within the walls, contain, the former 12,000, and the latter 8,000 acres. Boys informs us that "the internal regulations of these marshes are committed to the superintendence of exponditors. These are appointed by the Commissioners of Sewers, and are to take care that the repairs of the walls are maintained in due order, and that the costs attending the same be levied on each tenant according to the number of acres occupied by him; for which purpose they are to cause assessments to be made out, with the names of the occupiers, and the rateable proportions to be borne by them respectively; and these rates, which must be confirmed by the commissioners, are termed scots; and that when any occupier refuses to pay his scot, the exponditors can obtain a warrant from the commissioners, empowering them to distrain for the same, as for any other tax." These marshes are both appropriated to the purposes of breeding and feeding.

4560. *Salt water marshes* are subject to be overflowed at every spring tide, and at other times, when, from the violence of the wind or the impetuosity of the tide, the water flows beyond its usual limits. Their goodness is in a great measure analogous to the fertility of the adjoining marshes; and their extent differs according to the situation. Embankments, as it is remarked in *The Code of Agriculture*, are perhaps the only means by which they can be effectually improved, especially when they are deficient in pasture. However, where pasture abounds, they are in some cases more valuable than arable lands, the pasture operating as a medicine upon diseased cattle.

4561. *Marshes on the Thames*. In *The Agricultural Survey of Kent* it is asserted, that great profit is made by the renters of marshes bordering on the Thames, in the neighbourhood of London, from the grazing of horses, the pasture being deservedly accounted salubrious to that useful animal. Such horses as have been worn down by hard travel, or long afflicted with the farcy, lameness, &c., have frequently been restored to their pristine health and vigour, by a few months' run in the marshes, especially on the salt-ings; but as every piece of marsh land in some measure participates of this saline disposition, so do they all of them possess, in a comparative degree, the virtues above mentioned, and for this reason the Londoners are happy to procure a run for their horses, at 4s. or 5s. per week. Another method practised by the graziers in the vicinity of London is, to purchase sheep or bullocks in Smithfield at a hanging market, which, being turned into the marshes, in the lapse of a few weeks are not only much improved in flesh, but go off at a time when the markets, being less crowded, have considerably advanced in price; and thus a twofold gain is made from this traffic. Many of the wealthy butchers of the metropolis are possessed of a tract of this marsh land, and, having from their constant attendance at Smithfield, a perfect knowledge of the rise and fall in the markets, they are consequently enabled to judge with certainty when will be the proper time to buy in their stock, and at what period to dispose of them.

4562. *In various districts of the island* situated on the borders of the sea, or near the mouths of large rivers, there are many very extensive tracts of this description of land, which by proper drainage and enclosure may be rendered highly valuable and productive. This is particularly the case in Somersetshire and Lincolnshire. In the former of these counties, vast improvements have, according to Billingsley, as stated in his able *Survey*, been effected by the cutting of ditches, for the purpose of dividing the property, and the deepening of the general outlets to discharge the superfluous water. Many thousand acres which were formerly overflowed for months together, and consequently of little or no value, are now become fine grazing and dairy lands.

SECT. VII. *Downs and other Shore Lands.*

4563. *Downs* are those undulating smooth surfaces covered with close and fine turf met with in some districts on the sea-shore; the soil is sometimes sandy, and at other times clay or loam. In inland situations there are also down lands, as in Wiltshire, Lincolnshire, and Yorkshire; in the latter two counties they are called wolds.

4564. *Sandy downs on the sea-shore* are often more valuable in their natural state than after cultivation. In a state of nature they frequently afford good pasture for sheep and rabbits, and at other times produce grasses that may be used as food for cattle, or as litter. But the great object should be to raise plants which contribute to fix these soils, and to prevent them from being drifted by the winds, which often occasion incalculable

mischief. The most suitable plants for the purpose are, the *Elymus arenarius*, *Juncus arenarius*, *Arundo Donax*, *Ononis spinosa*, *Galium verum*, *Tussilago Petasites*, and a variety of other creeping-rooted plants and grasses. Of woody plants, the elder is one of the best for resisting the sea breeze, and requires only to be inserted in the sand in large truncheons. Where the sands on sea-shores are mixed with shells, and not very liable to drift, if they can be sheltered by fences or an embankment, and sown with white clover, it will be found both an economical and profitable improvement.

4565. The drift-sands of the outer Hebrides have in some places been consolidated and covered with verdure by "square pieces of turf, cut from solid sward, and laid upon the drifting surface, in steep places nearer to each other, and in less inclined places at a greater distance : on very rapid declivities the turfs are placed in contiguity. These turfs, although separated by intervals of a foot or so of sand, are not liable to be buried, except in very exposed places." (*Quar. Jour. Agr.* vol. i. p. 715.) N. Macleod, Esq. of Harris, has reclaimed and brought into useful permanent pasture above 120 acres of useless drifting sand, by planting it with *Arundo arenaria* (fig. 710.) in 1819. The operation is performed in September, by cutting the plants "about two inches below the surface with a small thin-edged spade, with a short handle, which a man can use in his right hand, at the same time taking hold of the grass with his left; other persons carrying it to the blowing-sand to be planted in a hole, or rather a cut, made in the sand, about eight or nine inches deep, (and deeper where the sand is very open and much exposed,) by a large narrow-pointed spade. A handful of *Arundo arenaria*, or bent grass, was put into each of these cuts, which were about twelve inches distant, more or less, according to the exposure of the situation. When properly fixed in the blowing-sand, the roots begin to grow and spread under the surface, in the course of a month after planting. This grass is relished by cattle in summer, but it is of greater value, by preserving it on the ground for wintering cattle : it would be injudicious to cut it, because it will stand the winter better than any other grass, and is seldom covered with snow. Neither wind, rain, nor frost will destroy it; but the old grass naturally decays towards the latter end of spring and the beginning of summer, as the new crop grows. White and red clover will grow spontaneously among this grass in the course of a few years, provided it is well secured. (*Trans. Highl. Soc.* vol. vi. p. 265.)



4566. Poor sandy soils in inland districts are not unfrequently stocked with rabbits. When the productions of arable lands are high, it is found worth while to break up these warrens and cultivate corn and turnips; but it frequently happens that, taking the requisite outlay of capital, and the expenses and risk into consideration, they do not pay so well as when stocked with rabbits. Such lands are generally well adapted for planting; but in this, as in every other case where there is a choice, circumstances must direct what line of improvement is to be adopted.



4567. Shores and sea beaches of gravel and shingle, without either soil or vegetation, are perhaps the most unimproveable spots of any; but something may be done with them by burying the roots of the arenarious grasses along with a little clay or loamy earth. Of these, the best is the *Arundo arenaria* and *Elymus arenarius* (fig. 711. a), already mentioned; and *E. geniculatus* (b) and *sibiricus* (c) would probably succeed equally well. The last grows on the sandy wastes of Siberia, and the preceding is found on the shores of Britain.

CHAP. V.

Improvement of Lands already in a State of Culture.

4568. A profitable application of many of the practices recommended in the chapters of this and the foregoing Book may be made to many estates which have been long under cultivation. It is certain, indeed, that the majority of those who study our work will have that object more in view than the laying out or improvement of estates *ab origine*. Few are the estates in Britain in which the farm lands do not admit of increased value,

by rectifying the shape of fields, adjusting their size, improving the fences, draining the soil, or adding to the shelter ; and few are the farmeries that may not be rendered more commodious. Of this, we shall give a few examples, after we have stated the general principles and modes of proceeding.

SECT. I. *General Principles and Modes of Procedure, in improving Estates already more or less improved.*

4569. *The groundwork of improvement*, on which a practical man may tread with safety and full effect, is an accurate delineation of the existing state, together with a faithful estimate of the present value, of the lands, and other particulars of an estate to be improved. A general map of the appropriated lands, readily exhibiting the several farms and fields as they lie, and showing the existing watercourses, embankments, fences, and buildings ; the woodlands, standing waters, morasses, and moory grounds ; the known mines and quarries ; together with the commonable lands (if any) belonging to the estate, forms a comprehensive and useful subject of study to the practical improver. It is to him, what the map of a country is to a traveller, or a sea-chart to a navigator. If an estate is large, a faithful delineation of it will enable him in a few hours to set out with advantages, respecting the connections and dependencies of the whole and its several parts, which, were he deprived of such scientific assistance, as many days, weeks, or months could not furnish. If on the same plan appear the rental value of each field or parcel of land, and the annual produce of each mine, quarry, woodland, and productive water, in its present state, the preparatory information which science is capable of supplying may be considered as complete ; and it remains with the artist to study with persevering attention the subject itself, in order to discover the species of improvements of which it is susceptible, and the suitable means of carrying them into effect.

4570. *The species of improvements* incident to landed property are numerous. They may, however, be classed under the following heads : — the improvement of the outline, and general consolidation of an estate by purchase, sale, or exchange : the improvement of the roads ; of the mines and minerals ; of the towns, villages, mills, and manufactories ; of the waters ; of the woods and plantations ; and of the farmeries and farm lands. This last subject is the most common, and to it we shall devote the succeeding section. To discuss the other species of improvement, as applied to old estates, would necessarily include so much of what has already passed in review in the foregoing Book, as to be wearisome to the reader.

SECT. II. *Improvement of Farmeries and Farm Lands.*

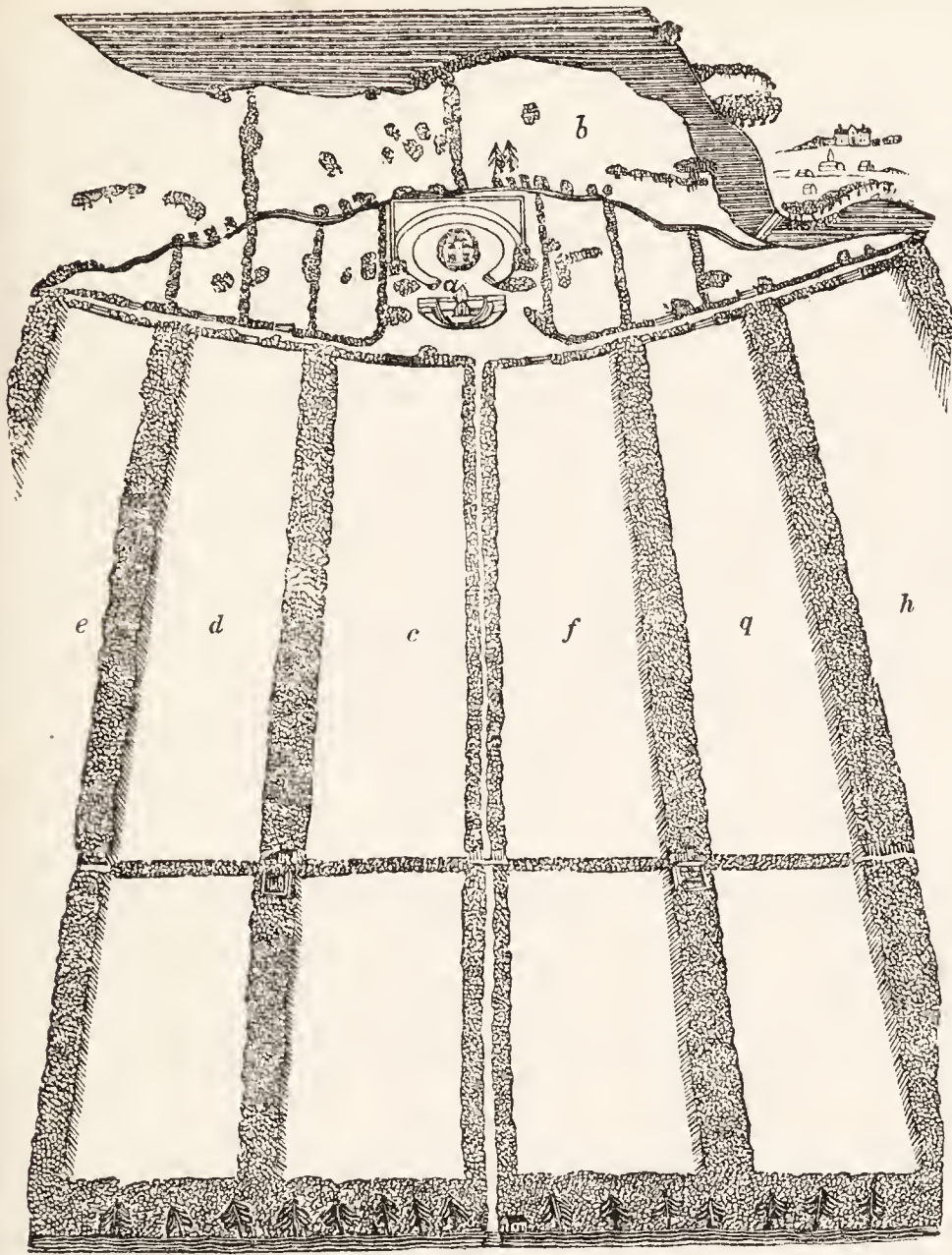
4571. *Farm lands are of more or less value according to the means of occupying them.* Arable lands in particular require buildings and other conveniences proportioned to the size of a farm. We frequently see tenants curbed in their operations, and incurring a waste of produce, through the want of sufficient homestalls. On the other hand, we sometimes observe a prodigality of expenditure on farm buildings ; thus not only sinking money unnecessarily, but incurring unnecessary expenses in subsequent repairs, by extending homesteads beyond the sizes of farms. In some cases, therefore, it will be found necessary to curtail the extent of farm buildings, as large barns ; in others to enlarge the yards, and in many to add and re-arrange the whole. The subject therefore may be considered in regard to design and execution ; but as we have already treated fully on laying out new farmeries, we shall here offer only a few general remarks as to alterations.

4572. *In improving the plan of a farmery*, the given intention is first to be maturely considered, and the several requisites to be carefully ascertained. The given site is next to be delineated, so as to show the existing buildings, yards, roadways, and entrances ; and then, by maturely studying the plan alternately with the site itself, the improver is to endeavour to trace out the most suitable alterations ; all the while keeping in view the perfection of arrangement, the situation and value of the existing buildings, and the expenses of alteration ; reconsidering the subject repeatedly, until the judgment be fully satisfied. It is much easier to plan and erect a new farmstead, than to improve one which is already erected. The former requires science and ingenuity only ; the latter good sense and judgment also.

4573. *In executing improvements on old farmeries*, some difficulty occurs as to the incorporation of new and old materials. If the situation and plan are likely to be of permanent approval, the new erections may be made in the most substantial manner ; keeping it in view that the old, which are repaired at the time, may afterwards be wholly renewed. But if the repairs and improvements are not to extend further than the duration of a lease, or till, by the expiration of various leases, some general plan of improvement can be determined on, then old materials may be used, or less permanent structures may be erected.

4574. As an example of adding part of a newly-enclosed common-field to a small anciently enclosed grass-farm (fig. 712.), we give the following case:

712



4575. The farmery (a) and ancient enclosed fields (b), are separated from the common field by a road, and bounded on the other side by a lake. The soil is a soft black earth on a gravelly subsoil, the surface a gentle slope towards the lake. The farm-house is supposed to be already placed in this ancient part; and the object in view is to unite a large portion of the common field, when enclosed, to each ancient farm, so as to get a fair rent for the lands at the least expense. The soil of this common field is a light poor sand, with nearly a flat surface. The circumstances of the country are favourable to large farms, the climate is dry, and the situation such as to require shelter. The number of acres to be enclosed and added to this farm is 1200. These will be most advantageously cultivated in six shifts of, 1, turnips (c); 2, barley (d); 3, artificial grasses (e); 4 and 5, the same (f, g); 6, wheat or oats (h). Each shift is proposed to be separated by a plantation for shelter, and no inferior divisions are made. In two of the plantations are field-barns, sheds, &c. where the corn grown on one-half of the arable lands is threshed by a moveable threshing-machine, and the straw consumed by cattle. There are cottages at each of these barns

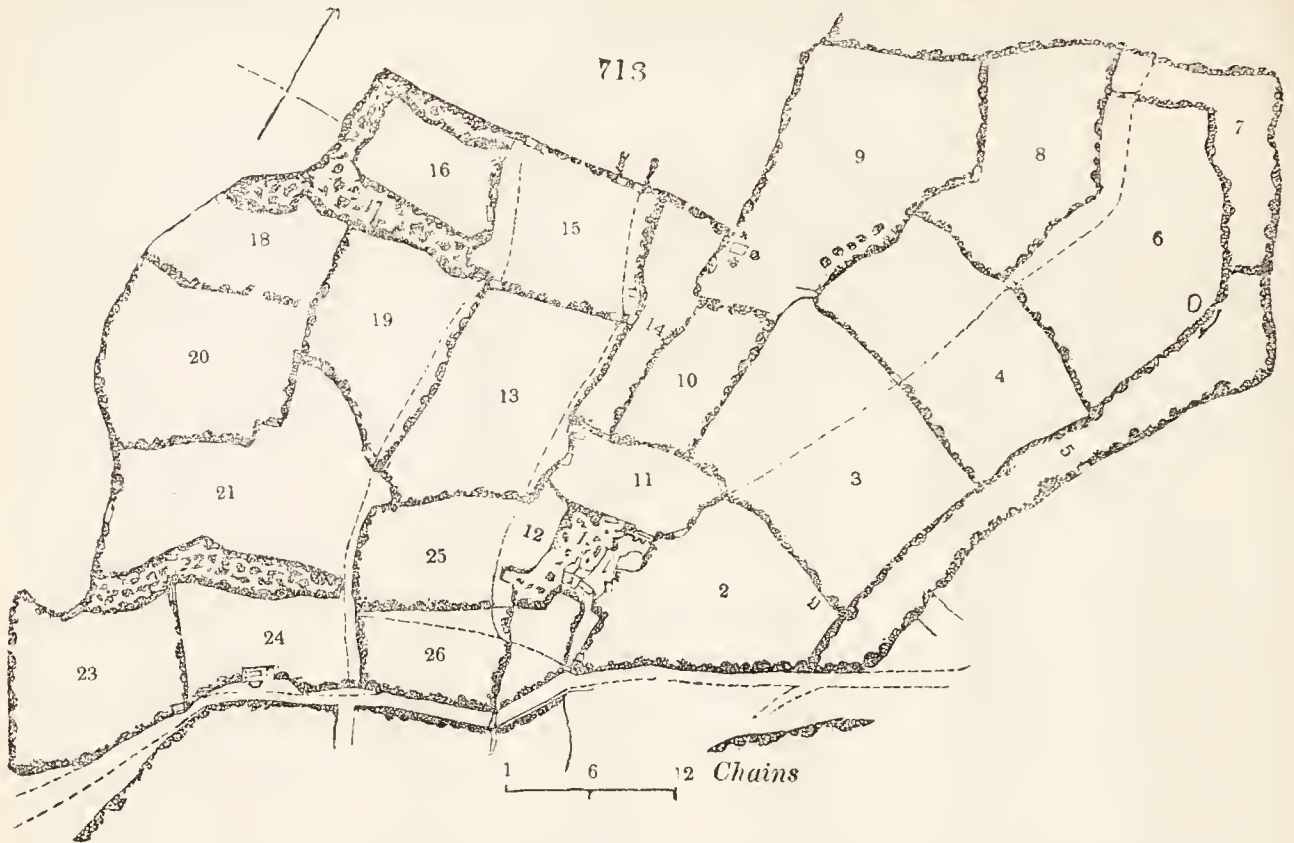
labourers to attend to the stock, &c. The ridges in each of the breaks or shifts are supposed to extend their whole length; or they may be ploughed as if the whole break were only one ridge, by which means not a moment is lost in turning at the ends, &c. Hereford or Devon oxen are supposed the beasts of labour on this farm.

4576. In place of the above rotation, wheat may be added after the second year of artificial grasses, and one shift kept entirely under saintfoin. This saintfoin division must of course be changed every sixth or seventh year. However, if a proper mixture of artificial grasses is sown, such as red, white, and yellow clover, rib-grass, burnet, saintfoin, timothy, cocksfoot, rye-grass, and soft-grass, the produce will be superior to that from either saintfoin or lucern alone, on a soil such as this, or even perhaps on any soil. Every agriculturist of observation must be aware that the efforts of annual and biennial plants are powerful for a few years at first, and that they uniformly produce a greater bulk than perennials: the latter seem to compensate for this temporary bulk by a steady durable produce.

4577. The old pasture near the house is supposed to be irrigated from the upper part of the lake, by a cut passing near the house. These pastures are particularly advantageous for early lambs, milch cows, &c. and for stock in general in seasons of great drought.

4578. Correcting the outlines of fields is one of the most obvious sources of amelioration on many, perhaps on most, estates. The advantages of proper sized and shaped enclosures have been fully pointed out, when treating of laying out farm lands, and in altering existing fences the same principles must be steadily kept in view; for though, unless by a total eradication of all the existing fences, every requisite may not be attainable, yet such a number may be gained as amply to compensate for the expense. In altering the shape and size of fields, besides the advantages resulting from the improvement in form, it will generally be found that a number of culturable acres may be added to the farm in proportion to the crookedness and width of the fences. Better drainage and roads will also be obtained, and where ornament is an object, a park-like appearance may be produced by leaving a single trees as part of what may have stood in the eradicated hedge-rows.

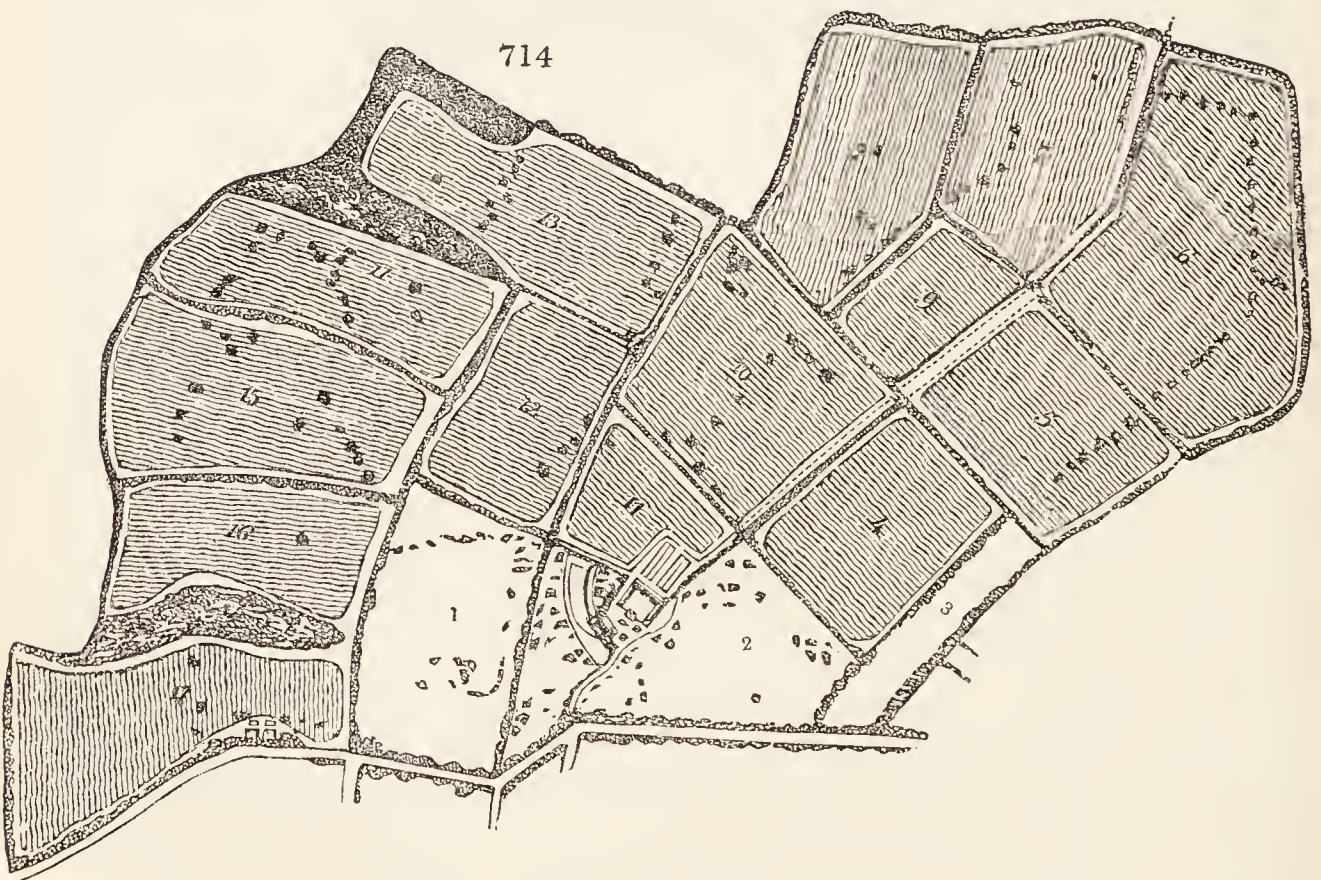
4579. As an example of improving the shape and size of fields, we shall refer to a farm of 350 acres, situated in Middlesex. (*fig. 713.*) In this case, the fields were larger than usual, but the fences were in



many parts from ten to fifteen yards in width, more resembling strips of copse wood than fences, as they contained hazel, dogwood, black and white thorns, wild roses, brambles, and a variety of native shrubs. The lines of these fences were so ill calculated for carrying off the surface-water, that in one half of the fields there were open gutters for the discharge of the water collected in the hedge-row ditches.

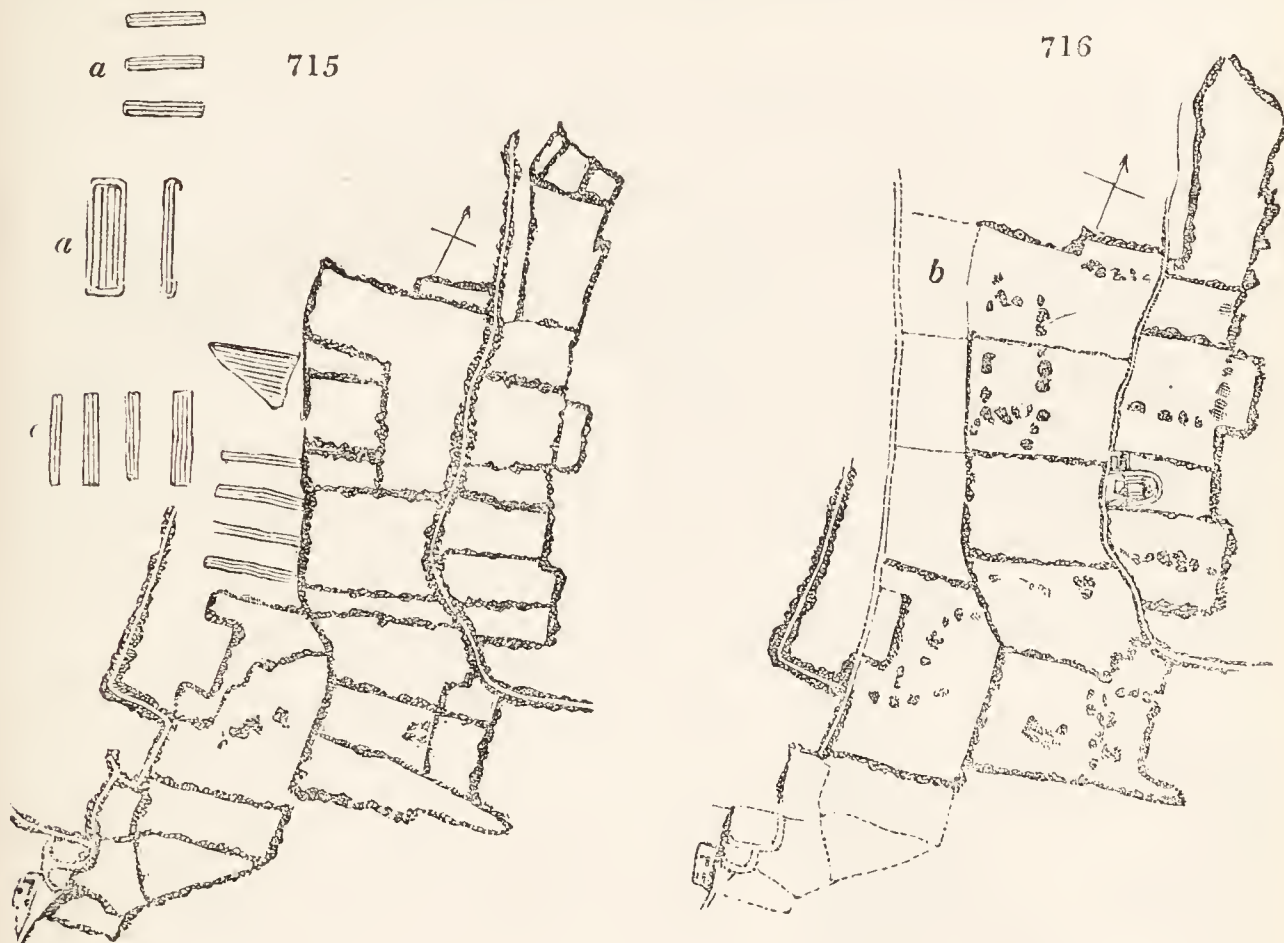
4580. In the centre of one field (25), for example, above an acre was rendered waste by the water from other fields (19, 20, and 21), which water, it is curious to remark, might, if led over the same acre agreeably to the principles of irrigation, have produced annually at least two loads and a half of good hay, in place of annually rendering the produce of this acre unmarketable. The water of some fields (as 16, 18, and part of 19,) ran in a diagonal direction through another (15), two acres of which might have been irrigated by it to advantage.

4581. In the farm, when altered (*fig. 714.*), the fields are more uniform in shape and size; their sides are parallel, and better adapted for ploughing the lands in straight ridges. All the surface-water is



carried off by the open fence drains. Access is had to every field by the shortest possible road from the farmery. Only two-thirds of the number of gates formerly required are requisite. Fifty acres are rendered useful which were formerly lost, or pernicious, by occupying space for which rent was paid, and by harbouring insects and noxious weeds; and as much rich vegetable earth is obtained from the old hedge banks as, spread abroad in every direction, may be said to manure at least ten acres. The whole is more open and healthful; and, from the number of single trees thrown into the fields, more elegant, and bearing a greater resemblance to a park. A part near the house (1, 2, 3) is in permanent pasture, and the rest (4, 5, 6, &c.) under a course of fallow, wheat, clover, beans, and wheat.

4582. *As an example of altering the fields and consolidating a farm, we submit the case of a meadow-farm, with the arable lands in a common field state. (fig. 715.)* By an act of enclosure, these scattered arable lands (a) were exchanged for others adjoining the meadow grounds (fig. 716. b), and the whole ren-



dered more compact and commodious. This farm, being intersected by a public lane, affords an example in which no private roads are wanted. The size and shape of the fields were improved, and the broad fences reduced as in the preceding case, and attended with the same advantages in an agricultural point of view.

4583. *But though in altering broad fences there are obvious and indisputable advantages to the farmer, yet, as justly observed by Loch, gain is not every thing.* "The fences on the Marquess of Stafford's estates," he says, "were liable to the same objection which is applicable to a great proportion of the counties of England. They are not composed of quick, at least but in a scanty degree; they for the most part consist of bushes, growing from the stump of every sort of forest-tree, intermixed with hazel, birch, hornbeam, maple, alder, willow, &c. They are planted on high and dry mounds, and thus are subject to constant decay. They occupy too much ground, provided agricul-

ture alone were the occupation of life. But as they give great protection, when they thrive, to the game, they become an important object of preservation, inasmuch as every thing must be of consequence which contributes to the sport, and has the effect of retaining the gentry of England much upon their estates. For this reason, it may occasionally be proper to consider of the best way to preserve these hedges at the least expense, in place of substituting more perfect ones in their stead; nor should one object exclusively be attended to in the agricultural improvements of so great and so wealthy a country." Such are Mr. Loch's ideas on game and hedges.

4584. *When farm-lands are exposed to high winds, interspersing them with strips or masses of plantation is attended with obviously important advantages.* Not only are such lands rendered more congenial to the growth of grass, and corn, and the health of pasturing animals, but the local climate is improved. The fact, that the climate may be thus improved, has, in very many instances, been sufficiently established. It is, indeed, astonishing how much better cattle thrive in fields even but moderately sheltered than they do in an open exposed country. In the breeding of cattle, a sheltered farm, or a sheltered corner in a farm, is a thing much prized; and, in instances where fields are taken by the season for the purpose of fattening, those most sheltered never fail to bring the highest rents, provided the soil is equal to that of the neighbouring fields which are not sheltered by trees. If we enquire into the cause, we shall find, that it does not altogether depend on an early rise of grass, on account of the shelter afforded to the lands by the plantations; but likewise that cattle, which have it in their power, in cold seasons, to indulge in the kindly shelter afforded them by the trees, feed better; because their bodies are not pierced by the keen winds of spring and autumn, neither is the tender grass destroyed by the frosty blasts of March and April. (*Plant. Kal.* p. 121.)

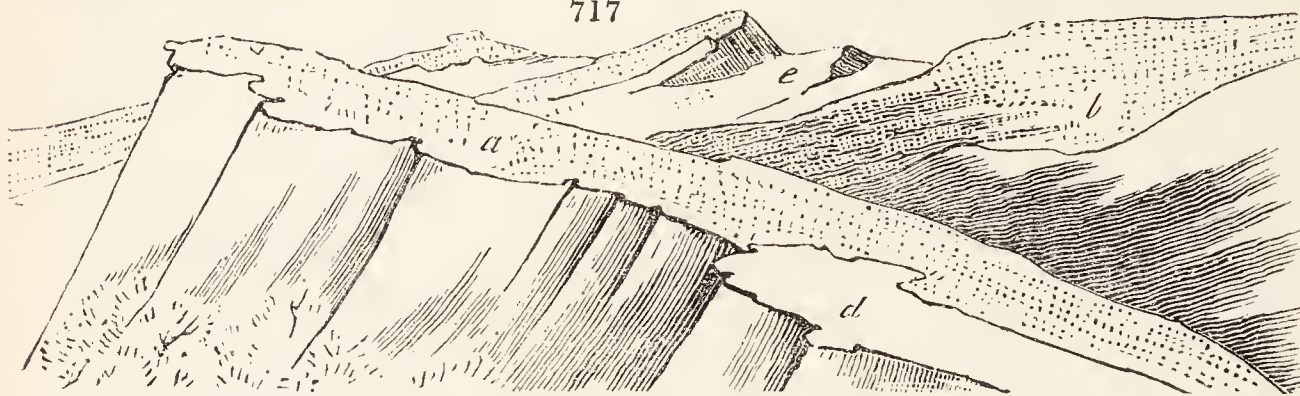
4585. *The operation of skreen plantations, in exposed situations, Marshal observes, is not merely that of giving shelter to the animals lodging immediately beneath them; but likewise that of breaking the uniform current of the wind,—shattering the cutting blasts, and throwing them into eddies; thus meliorating the air to some distance from them.* Living trees communicate a degree of actual warmth to the air which envelops them. Where there is life there is warmth, not only in animal but in vegetable nature. The severest frost rarely affects the sap of trees. Hence it appears, that trees and shrubs properly disposed, in a bleak situation, tend to improve the lands so situated, in a threefold way, for the purposes of agriculture; namely, by giving shelter to stock; by breaking the currents of winds; and by communicating a degree of warmth or softness to the air, in calmer weather.

4586. *The proper disposal of skreen plantations for this purpose is in lines across the most offensive winds, and in situations best calculated to break their force.* Placed across valleys, dips, or more open plains, in bleak exposures, they may be of singular use; also on the ridges, as well as on the points and hangs, of hills.

4587. *The width of skreen plantations* ought generally to be regulated by the value of the land for agricultural uses, and the advantages of the situation for the sale and delivery of timber. In ordinary cases, from two to four statute poles may be considered as an eligible width.

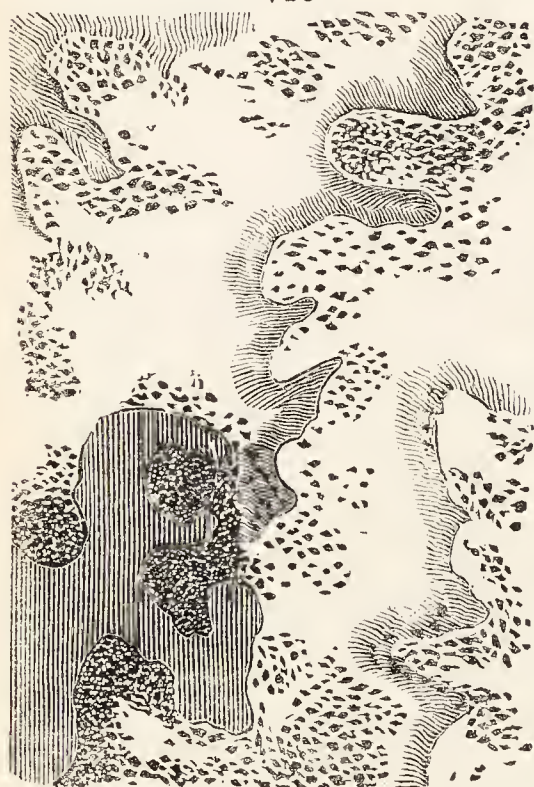
4588. *The form of plantations* for shelter, however, will not in every case be that of a stripe or belt of uniform width. In hilly, rocky, and other situations, different forms will suggest themselves, according to the situation and the objects in view. In rocky abrupt sites (*fig. 717.*) the plantation will consist of a

717



number of masses (*a, b, c*), of forms determined by the rocks and precipices, among which some of the most valuable pasture may be left as glades (*d, e*), for use, effect, and for the sake of game. Strips and hedges for sheltering, or separating arable lands, should be formed as much as possible in straight and parallel lines, in order not to increase the expense of tillage by short and irregular turnings. Straight parallel strips, on irregular surfaces, have a more varied appearance at a distance, than strips ever so much varied on a flat surface; for, in the former case, the outline against the sky is varied as much as that on the earth. In extensive hilly pastures, in which it is often desirable to produce shelter, and at the same time to plant only the most rocky and unproductive spots, the forms may be of the most irregular description; and by planting chiefly on the eminences and slopes (*fig. 718.*), shelter will be most

718



effectually produced, the pasture improved, the least valuable ground rendered productive in copse or timber, and the greatest richness and picturesque beauty conferred on the landscape. There are some fine examples of this in the hilly districts of Fifeshire: there, on many estates where nothing was sought for but profit and shelter, the greatest beauty has been produced; and the picturesque tourist now passes through glades and valleys, pastured by well-fed cattle and sheep, enlivened by rocks, thickets, hanging-woods, and occasional rills and lakes. Fifty years ago scarcely a tree was to be seen, and only the most inferior descriptions of live stock.

4589. *The species of woody plants* best adapted for shelter, are the rapid-growing and evergreen trees, as the Scotch pine; and such as are at the same time clothed with branches from the ground upwards, as the spruce fir, are the best of all trees for shelter, unless the situation is very elevated. Among the deciduous trees, the fast-growing branchy sorts are most desirable, as the larch, birch, poplar, willow; in very elevated situations, the birch, mountain-ash, and Scotch pine; exposed to the sea breeze, the elder and sycamore. To maintain a branchy leafy screen from the ground upwards, intermix tree and shrubs which stole; or such as grow under the shade and drip of others, as the holly, hazel, dog-wood, box, yew, &c. To produce shelter, and yet admit of the growth of grass below the trees, prune any sort to single stems, and use chiefly deciduous sorts.

4590. In *bleak and barren situations*, Marshal observes, the larch will generally be found the most profitable, as timber; but, being deciduous, it does not in winter, when its services are most wanted, afford as much shelter as the common pine. A skreen, to shelter live stock, should be close at the bottom, otherwise it is injurious rather than

beneficial; not only the blast acquiring additional current, but snow being liable to be blown through, and to be lodged in drifts on the leeward side, to the annoyance and danger of sheep that have repaired to it for shelter. A larch plantation margined with spruce firs, and these headed at twelve or fifteen feet high, would afford the required shelter for a length of years. The firs, or pines, thus treated, would be induced to throw out lateral boughs, and feather to the ground: while the larches, in their more advanced state of growth, would, by permitting the winter's winds to pass through the upper parts of the skreen, break the current and mellow the blast.

4591. In *more genial situations*, the beech, by retaining its leaves in winter, especially while it is young, forms a valuable skreen. If the outer margins were kept in a state of coppice wood, and cut alternately, and the middle ranks suffered to rise as timber trees, the triple purpose of skreen plantations might be attained in an eminent degree, and almost in perpetuity.

4592. In *deep-soiled vale districts*, which not unfrequently want shelter, skreens of oak might be managed in a similar way. Hollies, or other hardy evergreens, planted as underwood, in groves of either of the above descriptions, would, if suitable situations were assigned them, assist much in this intention.

4593. *A tall impervious fence* is, for the purpose of shelter to pasturing stock, nearly equal to a depth of coppice wood, and infinitely preferable to an open grove of timber trees; beside its additional use as a fence. There appears one *species* of fence which is peculiarly adapted to this purpose. This is the coppice mound hedge of Devonshire and South Wales; namely, a high wide bank or mound of earth, planted with coppice woods. This becomes, immediately on its erection, a shelter and a guard to pasture grounds.

4594. *The method of forming fences of this kind* is to carry up a stratum of earth, between two sod facings, "battering," or leaning somewhat inward, to the required height; and to plant on the top the roots and lower stems of coppice plants, gathered in woods or on waste grounds; or nursery plants adapted to the given situation. If the mound be carried to a full height, as five or six feet, and about that width at the top, and this be planted with strong plants, with stems cut off about two feet above the roots (in the usual practice of Devonshire), a suf-

ficient fence is thus immediately formed against ordinary stock. But if the bank be lower, or if nursery plants be put in, a slight guard run along the outer brink on either side, and leaning outward over the face of the mound, is required (especially against sheep) until the plants get up. If a hedge of this kind be raised as a *plantation fence* (especially on the lower side of a slope), the outer side only requires to be faced with sods; the hedge plants being set in a rough shelving bank, on the inner side.

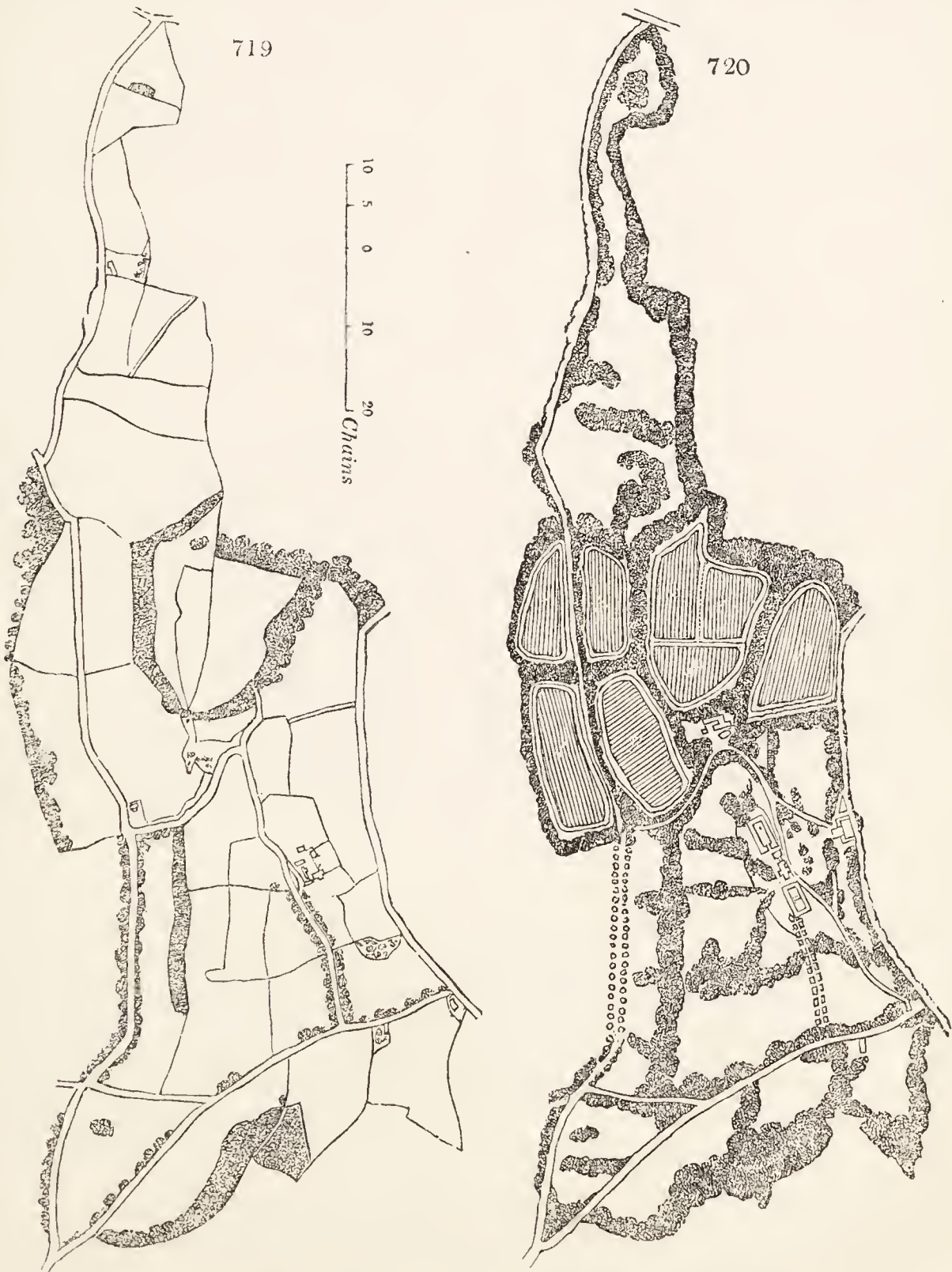
4595. *The species of hedge woods*, proper for mound fences, depends entirely on the soil and situation. On mounds of bad soil, in a bleak situation, the furze alone affords much shelter, and a good fence. The sides being kept pruned, so as to show a close firm face rising above the top of the bank, it is a secure barrier, even against the wilder breeds of Welsh sheep. The beech is commonly planted in high exposed situations; and in places more genial to the growth of wood, the hazel, the ash,

and the oak are the ordinary plants of hedge mounds. The willow tribe have a quality which recommends them, in situations where they will flourish; they grow freely from cuttings, or truncheons set in the ground; whereas, to secure the growth of ordinary coppice woods, rooted plants are required. The rock-willow (*Salix caprea*) will grow in high and dry situations.

4596. *On thin-soiled stony surfaces*, tall mounds are difficult to raise; and there *stone walls* are not only built at a small expense, but are convenient receptacles for the stones with which the soil is encumbered. But a stone wall, unless it be carried up to an inordinate height, at a great expense, is useless as a screen; and may be said to be dangerous as such, in a bleak exposed situation, for as soon as the drifting snow has reached the top of the wall, on the windward side, it pours over it, and inevitably buries the sheep which may be seeking for shelter on the leeward side. Hence, in a situation where shelter is required, it is necessary that a stone fence should be backed with a skreen plantation.

4597. *To plant trees for shade* may in some cases be requisite for agricultural purposes. Where this is the case, close plantations are seldom desirable, a free circulation of air being necessary to coolness; therefore trees with lofty stems, and large heads pruned to single stems, are preferable: the oak, elm, chestnut, and beech, for thick shade; the plane, acacia, and poplar, for shade of a lighter degree.

4598. *An example of sheltering a hill farm by plantation*, and at the same time improving the shape and size of fields, shall next be given. No farming subject affords better opportunities of introducing hedge-rows, and strips of planting, than hill-farms. The one under consideration (*fig. 719.*) is a small estate farmed by its owner: it consists of nearly 370 acres; and is situated in an elevated, picturesque part of a central English county. The soil is partly a flinty loam or chalk, and partly a strong rich soil, incumbent on clay. The fields are very irregular, bounded by strips of timber and copse. By the alterations and additions proposed (*fig. 720.*), all the most hilly and distant spots will be kept in permanent pasture; and the exposed and abrupt places, angles, &c. planted chiefly with oaks for copse, and beech for timber and shelter.



4599. *On hill farms in Scotland*, where shelter cannot be given to grass and stock by plantations, small circular inclosures have been adopted for that purpose. The diameter of these circles is from 10 to 30

feet, the height of the wall six or eight feet, and a conical roof is placed on them, and covered with turf; but many inclosures of this kind are formed without roofs. They are called in Selkirkshire stells, and were brought into notice, in 1822, by Captain, now Lord Napier, in his Treatise on Store Farming, a work to which we shall have recourse in a subsequent section.

CHAP. VI.

Execution of Improvements.

4600. *The mode in which improvements are executed* is a point of very considerable importance, and may materially affect their success as well as their expense. We shall first consider the different modes of execution, and next offer some general cautions to be kept in view in undertaking extensive works.

SECT. I. *Different Modes of procuring the Execution of Improvements on Estates.*

4601. *The necessary preliminary to the execution of an improvement*, is a calculation of the advantages to arise from it, and an estimate of the expense of carrying it into effect. If the former, taken in their full extent, do not exceed the latter, the proposed alteration cannot, in a private view, be considered as an improvement. The next point to be ascertained is the practicability, under the given circumstances of a case, of executing the plan under consideration. There are three things essential to the due execution of an improvement. 1st, an undertaker, or a person of skill, leisure, and activity, to direct the undertaking; 2d, men and animals with which to prosecute the work; 3d, money, or other means of answering the required expenditure. A deficiency in any one of these may, by frustrating a well-planned work after its commencement, be the cause not only of its failure, but of time, money, and credit being lost. — Improvements may be executed by the proprietor, either directly; gradually, by economical arrangements; or remotely, to a certain extent, by moral and intellectual means.

4602. *To execute improvements directly*, all that is necessary is to employ a steward or manager of adequate abilities and integrity, and supply him with the requisite plans, men, and money. This will generally be found the best mode of forming new roads, new plantations, opening new quarries or mineral pits, altering the course of waters, and all such creations or alterations as are not included in the improvement of farm lands.

4603. *To procure the gradual execution of improvements on farm lands*, various arrangements may be made with the tenants: for example, by granting long leases; letting them find the requisites of improvement, and take the advantages during their terms; by granting shorter leases, with a covenant of remuneration for the remainder of such improvements as they have made, at the time of quitting; by granting leases, at a low rent, for the first years of the term, to give the tenants time and ability to improve at their own expense; by advancing money to tenants at will, or, which is the same, making allowances of rent for specified improvements, to be executed by them under the inspection and control of the manager, they paying interest for the money advanced or allowed; by employing workmen on tenanted farms; the tenants in like manner paying interest on the money expended. The usual interest, till lately, was six per cent.; thus estimating the value of the improvement at sixteen years' purchase.

4604. *The moral and intellectual means of improving farm lands* consists, as Marshal has observed, in enlightening the minds of tenants. Though this mode is but of slow operation, and respects improvements in modes of culture, rather than such as require great outlay; yet it deserves notice in this place, as necessary to second the efforts of the landlord.

4605. *Farmers, as moral and intellectual agents*, may be divided into reading men, and illiterate beings: the first class derive hints for improvement from books; but the second can only, if at all, derive benefit from example.

4606. With respect to *improving farmers by books*, — agricultural newspapers, magazines, and county surveys, are probably what would be read with most eagerness; and as such works abound in statements of what actually has taken place in different situations, by farmers like themselves, perhaps they are the most likely to stimulate to exertion. Historical relations of the agriculture of other countries are also generally interesting to agriculturists; and though no great professional benefit is to be derived from them, yet they tend to enlarge and liberalise the mind, and promote a taste for knowledge. Under these circumstances, it may be worthy of consideration whether an agricultural library might not be established in the steward's office, on very extensive estates, for the use of tenants and all other persons belonging to the estate who chose to read from it. Itinerating libraries for the use both of farmers and their servants, or, indeed, of whoever chooses to use them, have for some time been established, and extensively used in East Lothian, and they are gradually being adopted in other counties both in Scotland and England. (*Gard. Mag.* vol. ii. p. 376.)

4607. *The establishment of schools* for the children of the lower class of tenants, and of cottagers of every description, is an obvious and important source of moral and intellectual improvement; and considering it as decided by experience and the most competent judges, that the education of the lower classes will tend greatly to their amelioration and the benefit of society at large, we are of opinion that, wherever they are not already established, they should be introduced. Working schools, somewhat in the German manner, both for boys and girls, would also be a material improvement in such districts as are behind in a taste for cleanliness, fireside comforts, cookery, and dress.

4608. *Examples as stimuli to improvement* may be exhibited in various ways: by letting a farm to a tenant of superior energy, or from a more improved district; by exhibiting improved implements and operations on one particular farm; by an itinerant ploughman of abilities, accompanied by a smith and carpenter, and with some implements, to go round the estate and instruct each tenant on his own farm; and finally, and perhaps preferably, by inducing every farmer to make a tour into some other district once a year.

4609. *In addition to these modes*, appropriate as we consider for two different classes of tenants, Marshal suggests the following as calculated to insure a spirit of improvement among all farmers not of sufficient energy and intelligence. They are to be adopted in various ways, by a proprietor, or by the manager of an estate, who has a knowledge of rural affairs, and who possesses the good will and confidence of its tenantry.

4610 *By personal attention alone* much is to be done. By reviewing an estate, once or twice a year; by conversing with each tenant in looking over his farm; and by duly noticing the instances of good management which rise to the eye, and condemning those which are bad; vanity and fear, two powerful stimulants of the human mind, will be roused, and an emulation be created among superior managers; while shame will scarcely fail to bring up the more deserving of the inferior ranks. If, after repeated exhortations, an irreclaimable sloven be discharged as such, and his farm given to another, professedly for his superior qualifications as a husbandman, an alarm will presently be spread over the estate, and none, but those who deserve to be discharged, will long remain in the field of bad management.

4611. *Even by conversation*, well directed, something may be done. If, instead of, on the one hand, collecting tenants to the audit, as sheep to the shearing, and sending them away, as sheep that are shorn; or, on the other, providing for them a sumptuous entertainment, and committing them to their fate in a state of intoxication; a repast suited to their conditions and habits of life were set before them; and, after this, the conversation bent towards agriculture, by distributing presents to superior managers, and specifying the particulars of excellence for which the rewards or acknowledgments were severally bestowed; a spirit of emulation could not fail to arise among the higher classes; while the minds of the lower order of tenants, and of the whole, would be stimulated and improved by the conversation.

4612. *By encouraging leading men* in different parts of a large estate, men who are looked up to by ordinary tenants; by holding out these as patterns to the rest; by furnishing them with the means of improving their breeds of stock; by supplying them with superior varieties of crops, and with implements of improved constructions: and, in recluse and backward districts, much may be done by tempting good husbandmen, and expert workmen, from districts of a kindred nature, but under a better system of cultivation, to settle upon an estate.

4613. *By an experimental farm*, to try new breeds of stock, new crops, new implements, new operations, and new plans of management; such as ordinary tenants ought not to attempt, before they have seen them tried. To this important end, let the demesne lands of a large estate, or a sufficient portion of them, be appropriated to a nursery of improvements, for the use of the estate; to be professedly held out as such, and be constantly open to the tenants; more particularly to the exemplary practitioners, the leading men of the estate, just mentioned; who, alone, can introduce improvements among the lower classes of an ignorant and prejudiced tenantry: it is in vain for a proprietor to attempt it. On the contrary, the attempt seldom fails to alarm, disgust, and prevent the growth of spontaneous improvements.

4614. *Under the present plan of demesne farming*, the tenants see expensive works going forward, which they know they cannot copy, and hear of extraordinary profits, by particular articles, which they are certain cannot be obtained by any regular course of business. They therefore conclude that the whole is mere deception, to gain a pretext for raising the rents of their farms above their value. Whereas, if the demesne lands were held out, as trial grounds, for their immediate benefit, and conducted, as such, in a manner intelligible to them, they would not fail to visit them. Instead of large proprietors attempting to rival the meanest of their tenants, in farming for pecuniary profit, which, on a fair calculation, they rarely, if ever, obtain; let their views in agriculture be professedly and effectually directed toward the pecuniary advantages of their tenants; for from these alone can their own arise, in any degree that is entitled to the attentions of men of fortune. Instead of boasting of the price of a bullock, or the produce of a field, let it be the pride of him who possesses an extent of landed property, to speak of the flourishing condition of his estates at large, the number of superior managers that he can count upon them, and the value of the improvements which he has been the happy means of diffusing among them. Leave it to professional men, to yeomanry and the higher class of tenants, to carry on the improvements, and incorporate them with established practices; to prosecute pecuniary agriculture in a superior manner, and set examples to inferior tenantry. This is strictly their province; and their highest and best view in life. It has been through this order of men, chiefly or wholly, that valuable improvements in agriculture have been brought into practice, and rendered of general use.

4615. *The possessor of an extent of territory has higher objects in view*, and a more elevated station to fill. As a superior member of society, it may be said, he has still higher views than those of aggrandising his own income. But how can a man of fortune fill what may well be termed his legitimate station in life, with higher advantage to his country, than by promoting the prosperity of his share of its territory; by rendering not one field, or one farm, but every farm upon it productive? This is, indeed, being faithfully at his post: and it is a good office in society, which is the more incumbent upon him, as no other man on earth can of right perform it, valuable as it is to the public.

SECT. II. *General Cautions on the Subject of executing Improvements.*

4616. *No work can be prudently commenced until the plan be fully matured*, not in idea only, but in diagrams, and in models, if the subject requires them; in order that every bearing and every hinge may be sufficiently foreknown: the site of improvement being reverted to, again and again, with the draught or the model in hand, until the judgment be satisfied and the mind be inspired with confidence. If a proprietor have not yet acquired sufficient judgment within himself, let him consult some one man, or one council of men, in whose knowledge and judgment he can confide; and thus fix a rallying point. Having brought his plan to a degree of maturity, in this private manner, he may then venture to publish it; and endeavour to improve it, by the advice of its friends, and the animadversions of its enemies.

4617. *If a proprietor wants judgment himself, and a friend to supply it*, let him not attempt the more difficult works of improvement. Yet how often we see, both in public and private life, men engaged in arduous undertakings, embarked on the wide ocean of business, without rudder or compass to guide them, depending on casual information, to help them on their way! They are consequently ever of opinion with the last persons they converse with. Such men's decisions and operations are always wrong: and for

an obvious reason. They consult those who are best able to inform them, first ; and receive their last impressions from those who are least capable to give them. Men who have neither judgment in themselves, nor any standard of practice to rally at, are liable to be led astray by the plausible schemes of theorists, the greater part of whom know nothing of the practical part of business, and who, by their calculations, both of expense in the outlay and of profit in the return, deceive both themselves and their friends or employers : some also may have sinister designs in view ; though we believe the errors of speculative men are in most cases owing to their being endowed with more imagination than judgment.

4618. *The execution of the different improvements of which an estate has been found susceptible being determined on, it is always advisable to begin with one which is obvious ; which may be effected with the greatest certainty ; which will repay most amply the expenses of carrying it into effect ; or which leads to other improvements, as embankment, drainage, &c.* To attempt a doubtful project, while plans which are obvious and certain remain unexecuted ; to try experiments before the list of known improvements has been gone through ; is seldom to be recommended, though it might sometimes turn out to be right.

4619. *All rural operations are more or less public, and as it were performed on a stage ; and spectators fail not to criticise.* If an experiment should prove abortive, or a proposed improvement turn out to be false, the ardour of the improver will be liable to be damped, his people to be discontented (as partaking in the discredit), and the expecting public around him to be disappointed. A few miscarriages, in the outset, might frustrate the best intentions and the most profitable schemes. But if, by prosecuting plain and certain improvements, a man once gain his own confidence, as well as that of the people about him, he may then venture to explore less beaten paths ; and this he will be able to do with greater caution, and more probability of success, by the experience already gained ; this being a further motive for pursuing the line of conduct here suggested.

4620. *All works of improvement should be executed with vigour.* Many falter in the midst of well-planned works, either, through the want of foresight or of business-like exertion ; in consequence, the money already expended lies dead, and the works are injured by the delay. Some works, as embankments and drainages, may be ruined by the slightest neglect or relaxation ; and, indeed, as Marshal observes, we see, in every department of the kingdom, these and other works deserted, and left to moulder into nuisances or disreputable eyesores.

4621. *In carrying on a work, execute every thing substantially, and in a workman-like manner.* Too often a false economy leads to the subversion of this principle. To save a few pounds in the first cost, materials of an inferior quality are laid in, or a quantity used insufficient to give the required substance and strength to the work. By either of these imprudences, its duration is abridged ; and the eventual loss, by repairs and renewal, may be ten times greater than the sum injudiciously saved in the original erection. Nevertheless, to increase the evil of these ill-judged savings, inferior workmen are employed ; or sufficient workmen at inferior prices, at which they cannot afford to make good work, nor can a superintendent urge them to make it under such circumstances. Consequently the work is ill performed, its duration is still more abridged, and a further loss is incurred by injudicious saving.

4622. *There are cases in which temporary works only are required.* A lease-tenant, for instance, wants to make an improvement which will last as long as his lease, without caring about its further duration. In such a case, it may be well-judged frugality and admissible “cleverness in business,” to work up cheap materials in a cheap way : but it seldom can be right in the proprietor of a hereditary estate, whose interest in it may be said to be perpetual, to proceed in the same manner. His best policy is to take favourable opportunities of laying in good materials at moderate prices ; to use them when duly seasoned ; and to employ good workmen at such prices as cannot furnish an excuse for bad workmanship, and will warrant him to enforce good.

4623. *Accomplish one work before another is commenced.* A work may be considered as accomplished when the chief difficulties are surmounted, and the chief cost expended ; and, till this is the case, it cannot be prudent to embark in another. By avoiding embarrassments, the execution of improvements becomes a present pleasure, as well as a source of future profit ; no half-finished works are left as monuments of disgrace to an estate and its owner ; no time nor interest of money is lost ; every work is brought into action and profit as it is finished ; and if, as it frequently will happen with the most prudent calculators, the estimated sum has been exceeded, due time may be taken to let the fund of improvement accumulate, so as to enable it to discharge the arrear, and to furnish, as wanted, the estimated sums requisite for the succeeding work.

BOOK IV.

MANAGEMENT OF LANDED PROPERTY.

4624. THE *management of an extensive landed estate*, like that of every other great property, is a business both of talent and integrity. In former times, when every proprietor may be said to have cultivated the whole of his agricultural territory, it constituted his whole occupation, when not engaged in war; or required a host of managers, if he was a man of the first rank. On the continent, and especially in Russia and Hungary, where estates are of enormous extent, and wholly farmed by the proprietor, the largest estates, as we have seen (621.), are managed by a court of directors, and an executive department, with a numerous body of superintendent officers, artists, and artisans. A better system is now adopted in this country, in consequence of the creation of professional farmers, who, taking large portions of territory from the owner for a certain number of years at a fixed rent, and on certain stipulations for mutual security, occasion little more trouble to the proprietor, during that period, than receiving payments. Hence it is that the management of estates in Britain, though important, is a more simple business than in any other country.

4625. *Where there are only tenanted holdings*, the business of management is very simple; where there are woodlands, it requires a person to look after that department; and where there are waters, quarries, and mines, a greater number of subordinate officers are requisite. But what often occasions most expense, and at the same time is attended with the least profit, is the management of the abstract rights belonging to an estate; such as manorial rights, quit-rents, and other feudal or antiquated trifles or absurdities, which require courts to be holden, and lawyers and other officers to be called in to assist. The only British author who has digested the business of managing estates into a regular system is Marshal, and we shall follow him in considering this subject: — 1st, as to the superintendents on the executive establishment of an estate; and, 2dly, as to the general business of management.

 CHAP. I.
Superintendents, or Executive Establishment of an Estate.

4626. *Though every man who cannot manage his own estate in all important matters, deserves to lose it*, yet, as extensive proprietors generally have their properties situated in different parts of the country, and have, besides, public duties to attend to, certain subordinate managers become necessary. In *The Code of Agriculture* it is stated, that no individual having a large estate is equal to the task of managing it, unless he is in the prime of life, dedicates his whole time to the business, and gives up every other occupation. It is there stated to have been found expedient, by the proprietor of an estate of great extent, to nominate two or three commissioners to assist him in its management. Under the superintendence of such commissioners, it is said, the affairs of a great property would be as well conducted as on the best managed small or moderate-sized estates; while the duties of the proprietor would principally be to carry the exercise of true benevolence into effect, which would consist in softening severe decisions; or in granting those marks of approbation and reward which, when bestowed by the proprietor himself, are the most likely to produce beneficial consequences. (*Code, &c. App. 58.*) Such may be the case on a few estates in the British isles not yet brought into a regular system of improvement, and about to be remodelled, of which a grand example occurs in the immense property of the Marquess of Stafford; but, in the great majority of cases, to each estate a manager of qualifications suited to its extent and duties, and a general receiver and controller in the capital or metropolis (if the proprietor and his banker cannot effect these duties between them) are all that is requisite. We shall first offer a few remarks on the qualifications and duties of managers, and next on the place of business and its requisites.

SECT. I. *Steward or Manager of an Estate, and his Assistants.*

4627. *The head manager of an estate* ought unquestionably to be the proprietor himself, or his representative, if a minor or otherwise incompetent. Next to the proprietor is his acting man of business, with proper assistants; together with such professional men as advisers as the circumstances of business may render necessary. A tenanted estate differs widely from other species of property; as giving power and authority over persons as well as things. It has, therefore, a dignity and a set of duties attached to it,

which are peculiar to itself. A man who receives ten thousand pounds a year from the public funds, for instance, is an insulated being, compared with him who receives the same income from landed property, and who is one of society's best members, provided his affairs are judiciously conducted. On the contrary, if, regardless of the dignity and the duties of his station, he lives but to dissipate his income, leaving the government of his estates and their inhabitants to those whose interest and honour are unconcerned in their welfare, or to those whose best interests lie in their derangement, he becomes at once an enemy to himself, to his family, and to the community. As unpardonable it would be in the possessor of a kingdom to be ignorant of state affairs, and unmindful of the ministers who reside about his court; or in the commanding officer of a regiment to be a stranger to his men, a priest to his parishioners, or a shepherd to his flock; as for the possessor of a tenanted estate to be ignorant of territorial concerns, and a stranger to his lands and their occupiers.

4628. Though it be *an essential part of the duty of a man of fortune to be intimately acquainted with his own affairs*, it does not follow that he should be absorbed in them, and neglect his duties as a superior member of society. In all matters of government and command, subordination is essential to good order and success. A commander in chief does not act as pioneer, nor does a naval commander reef his sails, or heave his anchor. Each has his subordinate officers to convey his commands, and men to execute them. But it is essentially necessary that the former should be well acquainted with military, the latter with naval, affairs. Every heir apparent, therefore, to a large landed property, should be regularly, or at least more or less, bred up in the knowledge of rural affairs, so as to fill with honour and profit the high station he has in view. But if the possessor of an estate has not been fortunately initiated in the knowledge which belongs to his station, the task of acquiring it is far from great.

4629. *On a large estate we generally find a resident manager*, a land steward, a man who has some knowledge of what is termed country business, and who acts under the control of his employer, or of a confidential friend, who is more conversant in rural concerns; or perhaps of a law agent, who knows less of them; or such residing steward, especially of a detached estate which lies at some distance from the residence of its proprietor, acts without control. In the last case, if he is a man of judgment, it is fortunate both for the landlord and tenant: but, on the contrary, if such possessory manager wants those requisite qualifications, the consequence becomes mischievous to the lands, their occupiers, their proprietors, and the community.

4630. *The requisite acquirements of an acting manager*, according to Marshal, are, a knowledge of agriculture, surveying, planting, some knowledge of mechanics, natural history, and skill in accounts. Agriculture is the only firm foundation on which the other required attainments can be securely reposed. It is not more essentially valuable in the superintendence than in the improvement of an estate. It is difficult to become an accurate judge of the value of lands without a practical knowledge of their uses; nor can any man without it properly appreciate the management of occupiers, much less assist them in correcting their errors, and improving their practice.

4631. *Land-surveying* is a requisite qualification. Not so much, however, for the purpose of measuring and mapping an estate at large, as for checking and correcting the works of professional men, as well as to assist in laying out its lands to advantage.

4632. *Planting*, and the management of woodlands, are acquirements that cannot be dispensed with. Nor should his knowledge and attention be confined to the surface of the estate entrusted to his care; he ought to have some acquaintance with natural history, chemistry, and experimental philosophy, to enable him to form just notions on the subject of the subterrene productions which it may contain.

4633. *Some knowledge of mechanics*, and other sciences that are requisite to the business of an engineer, may be highly useful in prosecuting the improvements incident to landed property.

4634. A competent knowledge of *rural architecture*, the doctrine of the strength of materials, and the superintendence of artificers, may be said to be of daily use.

4635. *A thorough knowledge of accounts* is essentially requisite to the manager of a landed estate.

4636. He should be a *man of good character, of upright principles, and conciliatory manners*; to set an example of good conduct to the tenants, and to become their common counsellor and peace-maker, in those trifling disputes which never fail to arise among the occupiers of adjoining land; and which too frequently bring on serious quarrels and lawsuits, that end in the ruin, not only of themselves, but of the tenements they occupy. A proprietor has, therefore, an interest in checking such disputes in the bud; and no man can do this with so much effect as a manager in whom they have a proper confidence, and who possesses a due share of popularity on the estate.

4637. *The acting manager requires certain assistants* on a large estate; especially if it lies in detached and scattered parts. Those in general use are a ground officer and clerk.

4638. *A land-reeve, woodward, or ground officer*, is required on each district or department of a large estate; to attend not only to the woods and hedge-timber, but to the state of the fences, gates, buildings, private roads, driftways, and watercourses; also to the stocking of commons (if any), and encroachments of every kind; as well as to prevent or detect waste and spoil in general, whether by the tenants of the estate, or others; and to report the same to the manager.

4639. *The office-clerk, book-keeper, or under steward*, is employed to form registers,

make out rentals, &c. and keep the accounts of the estate ; as well as to assist the manager in his more active employments ; also to act as his substitute in case of sickness, or absence ; and to become his successor in the event of his death, or other termination of his stewardship.

4640. *A law assistant, solicitor, or attorney, may next be considered as requisite to the good management of a landed estate.* For although much is to be done by judicious regulations, and the timely interposition and advice of a resident manager, such are the frailties of human nature, that, in a state of civilised society, and of property, legal assistance will sometimes be necessary. The error of country gentlemen consists, not in employing lawyers, but in committing the management of their landed estates to them. The employment of law agents as land stewards, however, is not without some reason. Farmers are not for the most part sufficiently skilled in accounts for taking the charge of a large estate ; and such of them as are capable, are commonly men of capital, and would not exchange their situation for the less independent one of a land steward. The division of labour, in the case of large estates, is not without its use, and is recognised in practice. A law agent collects the rents and keeps the accounts, often on a very small salary ; and in questions of a practical nature, such as the valuation of new leases, the modes of cropping, &c. he advises with a surveyor or land valuer. After all, however, a well chosen land-steward to reside upon the estate, and to consult, when necessary, with a lawyer, must be the best plan, even though his salary be higher than that of the law agent, who commonly acts for several proprietors, does not reside on any of their estates, and very likely, as we think, cannot do them justice.

4641. *In the feudal system, under which every manor court was a court of law, we may perceive the origin of law land-stewards.* It is allowed by the best agricultural writers in Europe (Chateauvieux, Thaer, Thouin, Mathieu de Dombasle, Sigismondi, Jovellanos, Young, Marshal, Brown, Coventry, &c.), *that these men by their rigid adherence to precedent in the clauses of leases, have contributed most materially to retard the progress of agricultural improvement.*

4642. *The land-surveyor is another professional man, whom the superintendent of an estate may want to call in occasionally.* Not merely to measure and map the whole or parts of the estate, but to assist in matters of arbitration, and the amicable settlement of disputes ; or to act himself, as valuer or referee.

SECT. II. *Land Steward's Place of Business, and what belongs to it.*

4643. *A manager's place of business may be considered in regard to its situation, accommodations, and appropriate professional furniture.*

4644. *The situation of the place of business should be under the roof of the proprietor's principal residence ; round which, and in its neighbourhood, some considerable parts of his estates may be supposed (as they ever ought) to lie.* If a large bulk of his property lie at too great a distance for tenants to attend at the principal office, and if on this he has a secondary residence, an inferior office is there required for such detached part. And it may be laid down as a rule, in the management of landed property, Marshal observes, that every distant part of an estate ought to have a place upon it (be it ever so humble) in which its possessor may spend a few days comfortably ; to diffuse over it a spirit of good order and emulation. He has known the most neglected and almost savage spot, such as are many landed estates in Ireland, reclaimed and put in a train of improvement by this easy method.

4645. *The accommodations requisite for a principal office are, a commodious business room, a small ante-room ; and a safe-keep, or strong room, fire proof, for the more valuable documents.*

4646. *The professional furniture with which an office of this description requires to be supplied are maps, rental-books, books of valuation, register, legal papers, and some others.*

4647. *A general map of the whole estate on a large scale is an obvious requisite ; and portable separate maps, with accompanying registers and other descriptive particulars, are useful in proportion as improvements may be in contemplation.*

4648. *Books of valuation are essential, especially where there are numerous small holdings on short terms.* In these registers are contained the number, name, admeasurement, and estimated value of each field, and of every parcel of land, as well as of each cottage or other building not being part of a farmstead, on the several distinct parts or districts of the estate. The valuations being inserted in columns, as they arise, whether by general surveys, or incidentally, headed with the names of their respective valuers, so that whenever a farm is to be relet, these columns may be consulted, and its real value fixed in a resurvey with the greater exactness.

4649. *A general register of timber trees, copsewood, and young plantations is particularly wanted where there is much hedgerow timber.* Marshal directs to specify in this register the number of timber trees in each wood, grove, hedgerow, and area, with the species, number, and admeasurement of each tree. He also recommends separate pocketbooks, containing the particulars of each division, or of a number of contiguous divisions, for the occasional use of the manager and woodreeve.

4650. *Contracts, agreements, accounts, letters on business, and other documents, should be intelligibly endorsed, dated or numbered, and arranged so as to be easily referred to.* A book of abstracts, or heads of papers of greater importance, should be made out to be referred to on ordinary occasions, and likewise

to serve as an index to the originals, which require a more secure repository than a common business-room.

4651. *Legal documents*, such as title deeds, legal decisions, awards of arbitration, counterparts of leases, securities, cash, bills, passed accounts, &c., as being the most important objects, should be carefully deposited in the safety-chest or strong room.

4652. *Portable registers* of the tenanted lands, in convenient pocket volumes, with maps on a small scale heading every farm, are, according to Marshal, who seems to have looked upon tenants as placed in a state of continual hostility with their landlords, a most invaluable description of books both for the manager and his employer. Two opposite pages being appropriated to each farm with its map, the following information should be given : —

Name of the farm and its number of acres.
The name of the tenant and the existing rent.
The tenancy ; if on lease, the term of expiring.
Any extraordinary covenant of the lease.
The number of cottages let with the farm.
The number of timber trees growing on it.
The number of orchard trees growing on it.

The eligibility of the plan and circumstances of the farm.
The eligibility of the occupier.
The eligibility of the present rent.
The state of the buildings, fences, and gates, roads, and watercourses.
The state of cultivation, and condition of the live stock.

4653. *Add*, among other things, the following, viz. : —

The repairs more immediately wanted.
The improvements of which the whole is susceptible.
The agreements entered into with the tenant.
The permissions granted him.
The injunctions delivered to him.
With a hint as to his personal character, and the number and general character of his family.

With any other incident or occurrence respecting the farm or its occupier, that requires to be remembered ; and with references to the books and papers which may pertain to the several particulars ; thus having at one view a complete abstract of the history and present state of every farm, together with the particulars of attention which each will require.

4654. *The trouble of forming an abstract of this kind*, or of renewing it when filled, or in order to adapt it to the varying circumstances of the several farms, is inconsiderable, compared with its uses, which are not only obvious in theory, but are fully established in practice. On returning to an estate, after twelve months' absence, Marshal has generally found, that, by consulting a register of this sort, and, through its means, making systematic enquiries respecting the incidents that have occurred on the several farms during his absence ; he, in this summary way, and before he entered upon a fresh view, became better acquainted not only with the general interests, but with the more ordinary business, of the estate, than the acting manager, who had constantly resided upon it, without such a remembrancer. This abstract or remembrancer, he says, ought not to comprehend tenanted farms only ; but should comprise woodlands, quarries, the demesne, &c. in hand ; as well as the more important improvements going on ; each of which ought to have its separate folio assigned it. To a proprietor, or his confidential friend, who only goes over his estate occasionally, such an intelligent companion is essentially serviceable. He cannot profitably direct, nor safely advise with, an acting manager, or other agent or officer of the estate, until he has consulted so infallible an oracle. The utility of such a register, while a proprietor is absent from his estate, if he can be said to be so, with such a faithful mirror in his possession, is too obvious to require explanation.

4655. *Among the instruments necessary for a manager's office*, may be included those requisite for surveying, mapping, levelling, measuring timber, and every description of country work, together with boring machines, draught measurers, weighing scales, some chemical tests, models, and such other articles as may be required or rendered useful by particular circumstances.

4656. *An agricultural library* may be considered an essential requisite ; including works on rural architecture, the prices and measuring of work, and other fluctuating matters ; and one of the best encyclopædias of universal knowledge. We have already suggested an important use to which such a library might be applied.

4657. *Such an establishment and place of business as has been described*, we agree with Marshal in thinking, many will consider as in some degree superfluous or extravagant. In many cases we admit it would be so ; but it is impossible to determine what things can be done without, unless a particular case were given. Such a minute register of farms, for example, would be quite ridiculous on an estate in East Lothian, where tenants are of sufficient wealth and respectability of manners to be treated as men ; and not watched and schooled like those which Marshal seems generally to have in view. As tenants of land become enlightened, they will be very differently treated from what in many places they are at present. As a proof of this, we have only to compare one district of country with another. In East Lothian, Berwickshire, and some other parts of Scotland, the farmers are as intelligent as their landlords ; and the transactions which take place between them resemble the transactions which take place between one mercantile man and another. In districts where the tenant has little capital, and where he is sunk in ignorance, he ranks with the labourer, and occupies his farm by a sort of sufferance. It is a pity that the ignorance and seclusion of such men do not admit of their comparing their state with that of others possessing no greater capital, but more knowledge and skill : it is a pity, we say, for the sake of their children, whom they might thus be induced to educate.

CHAP. II.

Duties of Managers of Estates.

4658. *The various duties of the manager*, or the proprietor, of a landed estate, may be considered under the heads of general business, business with tenants, and auditing accounts.

SECT. I. *General Principles of Business considered relatively to Land-Stewardship.*

4659. *The first and most general principle*, in this and every other department of business, is to embrace readily the several matters as they occur; and not to put them off from time to time, until they accumulate, and render the task difficult and irksome. The only artifice, it may be said, which a man of character can well employ in business is that of endeavouring to render it pleasurable; and, by meeting it cheerfully, as it rises, or as it becomes ripe for despatch, this desirable end will generally be attained: for, in that state a man not only enters upon it with pleasure himself, but he will generally find his opponent in the same temper of mind. Whereas, through delay, misunderstandings, idle tales, and groundless surmises are liable to intervene; the minds of both to be soured; a distant coolness to take place between them; and a barrier to be raised, which, though altogether imaginary, nothing but the mystic wand of the law may be able to remove.

4660. *There are three distinct methods of conducting business.* The first is that in which the parties meet, with fair intentions, to find out the point of equity, and there to close. In the second, they enter upon business, guarded with cunning, and armed with trick and artifice, as gamblers draw round a table, to take every advantage, fair or otherwise, which they can effect with impunity. The last method lies in the courts of law and equity.

4661. *A business founded on honourable intentions* is the only one in which a man of honour can voluntarily appear. Here honest men come, as indifferent persons, to arbitrate the matter in reference. In every settlement between man and man, there is a point of equity and right, which all good men are desirous to find; and when men of liberal minds fortunately meet and join in the search, it is seldom difficult to be discovered. Should some little difference of opinion arise, let them call in an umpire to decide between them; or leave the whole to the decision of three capable and disinterested men.

4662. *A man of strict integrity may become entangled in business with a man of looser principles.* In this case, it behoves him to be upon his guard; but still to enter into the negotiation with temper and civility. There is even a politeness in affairs of business which cannot be departed from on any occasion. Interruptions and schisms frequently arise, especially between men who are of keen sensibility, and who (though passably honest) are tenacious of their own interests, from mere matter of punctilio. The mind of either being once soured by neglect, or ruffled by disrespectful behaviour, the smooth path of peaceful negotiation is broken up, a spirit of warfare is roused, and advantages are taken, or attempted, which calm reason would not have suggested. Hence, when men of unequal degree are brought together in business, it is incumbent on the superior to set the example of liberality and civility of demeanour.

4663. *In extreme cases* there is no resource but the law; and here the most that an honest man can do is to procure, without loss of time, the best advice; and to spare no exertion or useful expense in bringing the dangerous and tormenting business to a speedy conclusion. Not only is a man's property endangered, while it is tossed on the troubled sea of the law; but his time and attention are led astray, and his peace of mind is liable to be broken in upon, thus deranging his ordinary concerns, and disturbing the stream of life. How much legal disputation might be prevented by a timely attention to business!

4664. *In forming connections in business, select the man who has a character to lose.* This principle should be invariably acted on: for if a man of established good character be properly treated, and determinately closed in with in case he demur or swerve from the right line of conduct, he will not forfeit his good name by doing a disreputable action; and must therefore come forward to the point of equity and justice.

SECT. II. *Management of Tenants.*

4665. *The general treatment of tenants and cottagers* may be considered as the most important part of every land-steward's occupation: it includes the mode and conditions of letting lands, and the time and manner of receiving rents. The idea of a landlord or his agents managing his tenants does certainly on the face of it appear an absurdity. The tenant is not more obliged to the landlord than the landlord is to the tenant; and therefore both parties being on an equality in point of obligation, the one ought not to require or have the power to manage the other. This power is given, however, by the ignorance of one of the parties, and the existing monopoly in favour of the other; and till these are done away with, by education and political changes, the ignorant part of farmers will always be managed by their landlords.

SUBSECT. 1. *Proper Treatment of Tenants.*

4666. *On every large hereditary estate, there are established customs and usages*, to which the proprietor and the occupiers consider themselves mutually amenable, though no legal contracts may subsist between them. Even where imperfect leases, or other legal agreements exist, still there is generally much left for custom and usage to determine. Though some of these may be improper, yet they ought to be strictly observed by its superintendent, until better can be placed in their stead; not merely on the score of moral justice, but, in the same observance, to set an example of integrity and good faith to the tenants. If a superintendent imprudently break through a custom or a covenant, what can he say to a tenant who follows his example?

4667. *A manager ought to set an example to the tenants* under his care of liberality and kindness. This is more especially applicable to the case of cottagers and others who rent small holdings. There are numberless small favours which he can bestow upon them without loss, and many with eventual advantage to the estate. A spirited improv-

ing tenant should be refused nothing that he can reasonably ask ; should have favours voluntarily conferred upon him, not merely as a reward for the services which he individually is rendering the estate, but to induce its other tenants to follow his example, and to make known to the whole that their conduct is observed, and distinctions made between good and bad managers.

4668. *Estates, like men, have their good and bad characters.* No skilful farmer who has a capital to lose, will take up his residence on an estate of known bad character. On the contrary, when once an estate has acquired the character of good faith and proper treatment of its tenantry, men of money and spirit will ever be anxious to gain a footing there. Besides, the character of an estate will ever involve that of its possessor : and, setting income at naught, it surely behoves a man of property to pay some attention to the character of his estates ; for what can well add more to the permanent respectability of a family of rank or fortune, than having its estates occupied by a wealthy and respectable tenantry ?

4669. *In a state of civilised society and property, one of the great arts of life is to teach character and interest to go hand in hand,* and on ordinary occasions to endeavour to turn every incident, as it fortuitously occurs, to their mutual advantage. If a tenant of capital and an improving spirit be found upon an estate, give him due encouragement, for the purposes already explained. On the contrary, if another is found to possess refractory habits, to swerve from his engagements, or to injure the lands in his occupation, it is but common prudence to take the first legal and fair opportunity of dismissing him, and supplying his place with another who is better qualified to fill it ; not more with a view of rescuing his particular farm from further injury, and of making an example of him in terror to others of similar habits, than to preserve and heighten the character of the estate.

4670. *These remarks may be considered as applicable chiefly to small tenants,* or such as from ignorance and want of leases may be considered in a state of bondage. It ought never to be in the power of a landlord to make “ an example of a tenant in terror to others ;” it is enough if this power be left to the laws. A tenant who rents a farm on certain conditions, and fulfils them, is, in point of obligation, on an equality with his landlord ; neither is obliged to the other : and while the one does not require those acts of kindness and liberality which Marshal inculcates, the other is not entitled to that submission and slavish deference so common among tenants at will, and indeed most others in England. It is justly observed by Brown (*Treat. on Rur. Aff.*) that the moral excitement, or degree of encouragement, given to the tenant for improving the ground put under his occupation, is regulated entirely by the terms or conditions of the lease under which he holds possession. If the conditions be liberal and judicious, and accommodated to the soil and situation of the land thereby demised to the tenant, all that is obligatory upon the proprietor is faithfully discharged. But when matters are otherwise, when the tenant possesses under a short lease, when the covenants or obligations are severe in the first instance and ultimately of little avail towards forwarding improvement, it may reasonably be inferred that the connection is improperly constituted, and that little benefit will thence follow either to the public or to the parties concerned. The proper view of a lease is, that it is merely a mercantile transaction reduced to writing, in which both parties are on an equal footing.

SUBSECT. 2. *Business of letting Farms.*

4671. *There are three methods of letting a farm :* putting it up to public auction, and taking the highest bidder for a tenant ; receiving written proposals, and accepting the highest offer ; and asking more rent for it than it is worth, haggling with different chappmen, and closing with him who promises to give the most money, without regard to his eligibility as a tenant. After a variety of obvious remarks, Marshal concludes, that “ seeing in every situation, there is at all times a fair rental value, or market price of lands, as of their products, there appears to be only one rational, and eventually profitable, method of letting a farm ; and this is, to fix the rent, and choose the tenant. In the choice of a tenant every body knows the requisite qualifications to be, capital, skill, industry, and character. The respective advantages of these qualities are amply developed in *The Treatise on Landed Property.*”

SUBSECT. 3. *Different Species of Tenancy.*

4672. *The different holdings in use in Britain are at will, from year to year, for a term of years, or for a life or lives.*

4673. *The tenant holding at will,* or until the customary notice be given by either party to the other, is without any legal contract, or written agreement ; the only tie between the owner and the occupier being the custom of the estate or of the country in which it lies, and the common law of the land. This may be considered as the simple holding which succeeded the feudal or copyhold tenure ; but which is now fast going into disuse.

4674. *Holding from year to year,* under a written agreement, with specified covenants, is a more modern

usage, and becoming more and more prevalent in some parts of England, and among small tenants, even where leases for a term of years were formerly granted.

4675. *Leases for a term of years*, as seven, fourteen, twenty-one, or a greater number of years, certain; but without the power of assignment, unless with the consent of the lessor.

4676. *Leases for lives*; as, one, two, three, or more, without the power of assignment. In Britain, life leases of this description are now rarely granted. In Wales and Ireland they are still prevalent; the rent being there settled according to the value of the land at the time of letting; as on granting a lease for a term. In the western extreme of England, what are termed life leases are still common: but they are rather pledges for money taken up, or deeds of sale for lives, than leases; for nearly the whole of the estimated sale value of the land, during the life term, is paid down at the time of purchase, the seller reserving only a quit rent, or annual acknowledgment.

4677. *A lease for a term of years*, or for two or more lives, can alone be favourable for the progress of agriculture. A farmer holding at will, or from year to year, may plough, sow, and reap; but he will, if a prudent man, be very careful not to make improvements, well knowing that the first effect would be a rise of rent or a notice to quit. Leases for a single life have the great disadvantage of uncertainty in duration, both as to landlord and tenant; and though the latter may insure a certain sum on his life for the benefit of his family, yet it were better that he should lay out that money in improving the farm. Leases on lives, renewable, are for all purposes of culture as good as freehold; but they have this disadvantage to a tenant, that they require a considerable part of his capital paid down, and a further draught on his capital on the falling in of any of the lives. Even the first of these payments would embarrass the great majority of professional farmers, and disable them from bestowing proper cultivation on the soil; but to a farmer with a surplus capital no description of lease can be better, as he lays out his surplus capital at the market rate of interest, and is, as it were, his own annuitant. To the landlord such leases cannot be advantageous; because, there being fewer who can compete for them, lands let on these conditions do not fetch their full price.

4678. *The fundamental principle* on which both the duration and conditions of leases are established is evidently this:—A agrees to lend to B a certain article for his use for an equivalent in money; but such is the nature of this article, that, in order to use it with advantage, B must possess it during a considerable time: he, therefore, requires a security from A to that effect; and A on his part requires a security from B that he will return the article at least in as good condition as when it was lent to him. The term of years for which the article is to be lent, and the precautions taken to insure its return without deterioration, are founded on experience, and vary according to the peculiar circumstances of lender and borrower. In general, however, this is obvious, that where the period of lending is not sufficient for profitable use, or the conditions required for ensuring the lender an undeteriorated return of the article unreasonable, the value of the loan or rent will be proportionably diminished. (*Sup. Enc. Brit. art. Agr.*)

4679. *In recurring to what actually exists in the best cultivated districts*, we shall quote the excellent observations of an experienced farmer and approved public writer:—“The general principle which should regulate the connection between landlord and tenant seems to be, that while the farm ought to be restored to the owner at the expiration of the tenant’s interest, at least without deterioration, the tenant should be encouraged to render it as productive as possible during his possession. In both of these views, a lease for a term of years is scarcely less necessary for the landlord than for the tenant; and so much is the public interested in this measure, that it has been proposed by intelligent men, to impose a penal tax on the rent of lands held by tenants at will.

4680. *That the value of the property is enhanced by the security which such a lease confers on the tenant* will be put beyond all doubt, if the rents of two estates for half a century back are compared; the one occupied by tenants at will, and the other by tenants on leases for a moderate term, and where the soil and situation are nearly alike in every respect. If the comparison be made between two tracts originally very different in point of value, the advantages of leases will be still more striking; while that which is held by tenants at will remains nearly stationary, the other is gradually, yet effectually, improved, under the security of leases, by the tenants’ capital; and, in no long period, the latter takes the lead of the former, both in the amount of the revenue which it yields to the proprietor, and in the quantity of produce which it furnishes for the general consumption. The higher rents and greater produce of some parts of Scotland than of many of the English counties, where the soil, climate, and markets are much more favourable, must be ascribed to the almost universal practice of holding on leases in the former country, in a much greater degree than to any of the causes which have been frequently assigned. Less than a century ago, what are now the best cultivated districts of Scotland were very far behind the greater part of England; and, indeed, had made very little progress from the time of the feudal system. It is not fifty years since the farmers of Scotland were in the practice of going to learn of their southern neighbours an art, which was then very imperfectly known in their own country. But in several parts of England there has been little or no improvement since, while the southern counties of Scotland have uniformly advanced; and at present exhibit very generally, a happy contrast to their condition in the middle of the last century.

4681. *In respect to farmers themselves*, it cannot be necessary to point out the advantages of leases. It may be true, that, under the security of the honour of an English landlord, tenants at will have been continued in possession from generation to generation, and acquired wealth which he has never, like the landholders of some other countries, attempted to wrest from them. But there are few individuals in any rank of life, who continue for a length of time to sacrifice their just claims on the altar of pure generosity. Something is almost always expected in return. A portion of revenue in this case is exchanged for power, and that power is displayed not only in the habitual degradation of the tenantry, but in the control over them, which the landlord never fails to exert at the election of members of parliament, and on all other political emergencies. No prudent man will ever invest his fortune in the improvement of another person’s property, unless, from the length of his lease, he has a reasonable prospect of being reimbursed

with profit; and the servility which holding at will necessarily exacts is altogether incompatible with that spirit of enterprise which belongs to an enlightened and independent mind.

4682. *Every measure which has a tendency to fetter the productive powers of the soil*, must deeply affect the public at large, as well as depress one of the largest and most valuable classes. It is clearly their interest, that corn and other provisions should be supplied in abundance, and the people of England may justly complain of the want of leases, as one of the principal causes which check the improvement of their own territory.

4683. *What ought to be the term of a lease* can only be determined by a reference to the circumstances of each particular case. Lands naturally rich, or such as have already been brought to a high degree of fertility, requiring no great investment of capital, and returning all or nearly all the necessary outlay within the year, may be advantageously held upon short leases, such as perhaps give time for two, or at most three of the rotations or courses of crops to which the quality of the soil is best adapted. The practice of England in this respect is extremely various, almost every term, from twenty years downwards, being found in different parts of it. In Scotland, by far the most common period is nineteen years, to which it was formerly the practice, in some places, to add the life of the tenant. In that country, even when it is thought expedient to agree for a much longer term, this is still expressed in periods of nineteen years, a sort of mysterious cycle, which seems to be no less a favourite with the courts of law than with landholders and farmers. Yet this term is somewhat inconvenient, as it can never correspond with any number of the recognised rotations of arable land.

4684. *A lease for twenty years*, it has been maintained by several writers, is not sufficient to reimburse a tenant for any considerable improvements, and landholders have often been urged to agree to a much longer term, which, it is alleged, would be not less for their own interest than for that of the tenant. This is a question which our limits do not permit us to discuss; but, after viewing it in different lights, assisted by the experience of long leases in different parts of Scotland, we cannot help expressing some doubts of their utility, even in so far only as it regards the parties themselves; and we are decidedly of opinion, that a greater produce will be brought to market, from any given extent of land held on successive leases of twenty years, for half a century, than if held on one lease of that duration, whether the term be specified, or indefinite as is the case of a lease for life. As a general mode of tenure, leases for lives seem to us particularly objectionable.

4685. *The great advantages of a lease* are so well known in Scotland, that one of her best agricultural writers, himself a landed proprietor, has suggested a method of conferring on it the character of perpetuity, to such an extent as, he thinks, would give ample security to the tenant for every profitable improvement, without preventing the landlord from resuming possession upon equitable terms, at the expiration of every specified period. But the author of this plan (Lord Kaimes), in his ardent wishes for the advancement of agriculture, at that time in a very backward state in his native country, seems to have overlooked the difficulties that stood in the way of its adoption; and the great advance in the price of produce, and consequently in the rate of rents, since his lordship wrote, have long since put an end to the discussion which his proposal excited. For a form of a lease on his plan, the reader may consult Bell's *Treatise on Leases*; and the objections to the plan itself are shortly stated in the supplement to the sixth edition of *The Gentleman Farmer*, recently published.

4686. *Long leases granted upon condition of receiving an advance of rent at the end of a certain number of years* have been granted: but covenants of this kind, meant to apply to the circumstances of a distant period, cannot possibly be framed in such a manner as to do equal justice to both parties; and it ought not to be concealed, that, in every case of a very long lease, the chances are rather more unfavourable to the landlord than to the farmer. If the price of produce shall continue to rise as it has done, till very lately, for the last forty years, no improvements which a tenant can be expected to execute will compensate the landlord's loss; and if, on the other hand, prices shall decline, the capital of most tenants must be exhausted in a few years, and the lands will necessarily revert to the proprietor, as has been the case of late in many instances. Hence a landlord, in agreeing to a long lease, can hardly ever assure himself that the obligations on the part of the tenant will be fully discharged throughout its whole term, while the obligations he incurs himself may always be easily enforced. He runs the risk of great loss from a depreciation of money, but can look forward to very little benefit from a depreciation of produce, except for a few years at most. Of this advantage a generous man would seldom avail himself; and, indeed, in most instances, the advantage must be only imaginary, for it would be over-balanced by the deterioration of his property." (*Sup. Encyc. Brit. art. Agr.*)

4687. *There are various objections made to leases of nineteen or twenty-one years*. Some of these are of a feudal and aristocratical nature; such as the independence it gives the tenants, who may become purse-proud and saucy under the nose of their landlord, &c. A greater objection has arisen from the depreciation of British currency during the last ten years of the eighteenth, and first ten of the nineteenth centuries. Various schemes have been suggested to counteract this evil; but the whole of them are liable to objections, and it may be doubted if it admits of any remedy, except a compromise between the parties.

SUBSECT. 4. *Rent and Covenants of a Lease.*

4688. *To avert the evils of fixed money rents*, and long leases, both to landlords and tenants, the best mode known at present is the old plan of corn rents. This plan was first revived in 1811, by a pamphlet published in Cupar, which attracted considerable attention, and has led to the adoption in various parts of Scotland, of a mixed mode of paying rents, partly in corn or the price of corn, and partly in money. In hilly districts, wool, or the price of wool for an average of years, is sometimes fixed on instead of corn. We shall quote from the same intelligent writer on the duration of leases, his sentiments on corn rents, and subjoin his observations on covenants.

4689. *Though the most equitable mode of determining the rent of lands on lease*, would be to make it rise and fall with the price of corn; yet a rent paid in corn is liable to serious objections, and can seldom be advisable in a commercial country. It necessarily bears hardest on a tenant when he least able to discharge it. In very bad seasons, his crop may be so scanty, as scarcely to return seed and the expenses of cultivation, and the share which he ought to receive himself, as the profits of his capital, as well as the quantity allotted to the landlord, may not exist at all. Though, in this case, if he pays a money rent, his loss may be considerable, it may be twice or three times greater if the rent is to be paid in corn, or according to the high price of such seasons. In less favourable years, which often occur in the variable climate of Britain, a corn rent would, in numerous instances, absorb nearly the whole free or disposable produce, as it is by no means uncommon to find the gross produce of even good land reduced from twenty to fifty per cent. below an average in particular seasons. And it ought to be considered, in regard to the landlord himself, that his income would thus be doubled or trebled, at a time when all other classes were suffering from scarcity and consequent dearth; while, in times of plenty and cheapness, he might find it difficult to make his expenses correspond with the great diminution of his receipts. It is of much importance to both parties, that the amount of the rent should vary as little as possible from any unforeseen causes, though tenants in general would be perhaps the most injured by such fluctuations.

4690. To obviate these and other objections to a corn rent, and to do equal justice at all times to both landlord and tenant, a plan has been lately suggested for converting the corn into money, adopting for its price, not the price of the year for which the rent is payable, but the average price of a certain number of years. The rent, according to this plan, may be calculated every year, by omitting the first year of the series, and adding a new one; or, it may continue the same for a certain number of years, and then be fixed according to a new average. Let us suppose the lease to be for twenty-one years, the average agreed on being seven years, and the first year's rent, that is, the price of so many quarters of corn, will be calculated from the average price of the crop of that year, and of the six years preceding. If it be meant to take a new average for the second and every succeeding year's rent, all that is necessary is, to strike off the first of these seven years, adding the year for which the rent is payable, and so on during all the years of the lease. But this labour, slight as it is, may be dispensed with, by continuing the rent without variation for the first seven years of the lease according to the average price of the seven years immediately preceding its commencement, and, at the end of this period, fixing a new rent, according to the average price of the seven years just expired, to continue for the next seven years. Thus, in the course of twenty-one years, the rent would be calculated only three times; and for whatever quantity of corn the parties had agreed, the money payments would be equal to the average price of fourteen years of the lease itself, and of the seven years preceding it; and the price of the last seven years of the old lease would determine the rent during the first seven years of the new one.

4691. *The landlord and tenant could not suffer*, it has been thought, either from bad seasons, or any change in the value of the currency, should such a lease as this be extended to several periods of twenty-one years. The quantity of corn to be taken as rent, is the only point that would require to be settled at the commencement of each of those periods; and though this would no doubt, be greater or less, according to the state of the lands at the time, yet it may be expected, that in the twenty-one years preceding, all the tenant's judicious expenditure had been fully replaced. Instead of the twofold difficulty in fixing a rent for a long lease, arising from uncertainty as to the quantity of produce, which must depend on the state of improvement, and still more, perhaps, from the variations in the price of that produce; the latter objection is entirely removed by this plan; and in all cases where land is already brought to a high degree of fertility, the question about the quantity of produce may likewise be dispensed with.

4692. *If the corn-rent plan be applied to leases of nineteen or twenty-one years*, the inconvenience resulting from uncertainty as to the amount of rent, as well as other difficulties which must necessarily attend it, would be as great, perhaps, as any advantages which it holds out to either of the parties. If it be said that a rent, determined by a seven years' average, could not suddenly nor materially alter, this is at once to admit the inutility of the contrivance. The first thing which must strike every practical man is, that corn is not the only produce of a farm, and in most parts of Britain, perhaps not the principal source from which rent is paid; and there is no authentic record of the prices of butcher meat, wool, cheese, butter, and other articles in every county to refer to, as there is of corn. This is not the place to enquire whether the price of corn regulates the price of all the other products of land, in a country whose statute books are full of duties, bounties, drawbacks, &c., to say nothing of its internal regulations; but it is sufficiently evident that, if corn does possess this power, its price operates too slowly on that of other products to serve as a just criterion for determining rent on a lease of this duration. Besides, in the progress of agriculture, new species or varieties of the cerealia themselves are established even in so short a period as twenty-one years, the prices of which may be very different from that of the corn specified in the lease. What security for a full rent, for instance, would it give to a landlord, to make the rent payable according to the price of barley, when the tenant might find it more for his interest to cultivate some of the varieties of summer wheat, lately brought from the Continent? or, according to the price of a particular variety of oats, when, within a few years, we have seen all the old varieties superseded, throughout extensive districts, by the introduction of a new one, the potato-oat, which may not be more permanent than those that preceded it? There can be no impropriety, indeed, in adopting this plan, for ascertaining the rent of land kept always in tillage; but it would be idle to expect any important benefits from it, during such a lease as we have mentioned.

4693. *The corn-rent plan, in the case of much longer leases*, will no doubt diminish the evils which we think are inseparable from them, but it cannot possibly reach some of the most considerable. Its utmost effect is to secure to the landholder a rent which shall in all time to come be an adequate rent, according to the state of the lands and the mode of cultivation known at the date of the lease. But it can make no provision that will apply to the enlargement of the gross produce from the future improvement of the lands themselves, or of the disposable produce from the invention of machinery and other plans for economising labour. And the objections just stated, in reference to a lease of twenty-one years, evidently apply much more forcibly to one of two or three times that length. Old corn-rents, though much higher at present than old money-rents, are seldom or never so high as the rents that could now be paid on a lease of twenty-one years. But, independently of these considerations, which more immediately bear upon the interests of the parties themselves; one insuperable objection to all such leases is, that they partake too much of the nature of entails, and depart too far from that commercial character which is most favourable to the investment of capital, and consequently to the greatest increase of land produce.

4694. *The most recent opinions on this subject* are in favour of a money rent, or of a rent formed partly from the average prices of produce, and partly of money, but somewhat complicated in its arrangement, and therefore not likely to come into general use. There seems, indeed, no essential reason why rents in agriculture should not be regulated on the same general principle as rents in commerce; and were it not for the extraordinary fluctuation that has taken place in the currency of the country within the last forty years, it is more than probable no such alteration of principle would ever have been thought of. The reader who wishes to enter more at length into this subject, may consult the most recent works on political economy, and especially *M'Culloch's Principles*. He will also find a paper on the subject, of some practical value, in the *Quarterly Journal of Agriculture*, vol. i. p. 809. and vol. ii. p. 126.

4695. *Mr. M'Culloch*, in the second edition of his *Principles of Political Economy*, with reference to corn rents, observes, that the disturbing effects of changes in the value of money are averted, at the same time that the effect of those which occur in the cost of producing corn are mitigated. This plan, he adds, is, however, defective, inasmuch as it obliges the tenant to pay more than the fair value of his farm in scarce years; while, on the other hand, it has the effect of improperly reducing the landlord's rents in years of unusual plenty. A simple device has, however, been fallen upon, which has gone far to reduce these defects: this consists in fixing a *maximum* and a *minimum* price, it being declared in the lease that the produce to be paid to the landlord shall be converted into money, according to the current prices of the year; but that, to whatever extent prices may rise above the maximum price fixed in the lease, the landlord shall have no claim for such excess of price. By means of this check, the tenant is prevented from paying any great excess of rent in scarce years. And to prevent, on the other hand, the rent from being improperly reduced in very plentiful years, a minimum price is agreed on by the parties; and it is stipulated that, to whatever extent prices may sink below this limit, the landlord shall be entitled to receive this minimum price for the fixed quantity of produce payable to him. This plan has been introduced into some of the best cultivated districts in the empire, particularly East Lothian and Berwickshire; and the experience of the estates in which it has been adopted shows that it is as effectual as can well be desired, for the protection of the just rights of both parties, and for securing the progress of agriculture.

4696. *The terms of payment of rent* differ a little in different districts and countries. Rents, in Scotland, are paid either previously to the first crop being reaped, when they are called *fore-rents*; or they are paid

subsequently to the reaping, when they are termed *back-rents*. In England, it is believed that, with a few exceptions in the border counties, back-rents are not in use. The effect of these rents is, to afford a long credit to the tenant; it is assumed that his means of paying any year's rent are chiefly derived from the sale of the crop of that year, and hence he is allowed to reap and sell the crop, in order to pay the rent: thus, if he enters at Whitsunday, 1829, and at separation of crop 1829 from the ground, his first year's rent is that of 1830, and his first year's payment is usually made at Martinmas 1830, and Whitsunday 1831. Were he to pay what is termed fore-rent, his first term's payment would be at Martinmas 1829, and his second at Whitsunday 1830; thus completing his first year's rent before his crop had been reaped. Wherever custom has established the system of back-rents, it should not be disturbed; by means of the credit afforded, tenants are enabled to take land with a smaller capital, and to expend those funds in the improvement of the farm, of which they must otherwise have been deprived. It must be thus attended with one or other of two advantages to the landlord; first, by bringing farms more within the reach of the funds of takers, it excites greater competition; or, secondly, it leaves a fund in hand to the lessee, for the immediate cultivation of his land. In Scotland this system is attended with no hazard, since landlords have always, in that country, a security, by means of their legal rights of hypothec, on the crop of the tenant. In the case of farms merely pastoral, indeed, the landlord's claims will not be well secured, because a tenant removing at Whitsunday will have left no crop behind to answer for the rent: in farms of this nature, accordingly, rents are stipulated to be paid in advance. (*Quar. Jour. Agr.* vol. ii. p. 134.)

4697. *A lease for a term of years is not, in all cases, a sufficient encouragement to spirited cultivation; its covenants in respect to the management of the lands may be injudicious; the tenant may be so strictly confined to a particular mode of culture, or a particular course of crops, as not to be able to avail himself of the beneficial discoveries which a progressive state of agriculture never fails to introduce. Or, on the other hand, though this is much more rare, the tenant may be left so entirely at liberty, that either the necessity of his circumstances, during the currency of the lease, or his interest towards its expiration, may lead him to exhaust the soil, instead of rendering it more productive. When a lease therefore is either redundant, or deficient in this respect, where it either permits the lands to be deteriorated, or prevents their improvement; the connection between landlord and tenant is formed upon other views, and regulated by some other principle, than the general one on which we think it should be founded.*

4698. *Restrictive covenants are always necessary to the security of the landlord, notwithstanding the high authority of Dr. Smith to the contrary, and in some cases beneficial to the tenant. Their expediency cannot well be questioned in those parts of the country where an improved system of agriculture has made little progress. A landholder, assisted by the advice of men experienced in framing these covenants, cannot adopt any easier or less offensive plan for the improvement of his property, and the ultimate advantages of his tenantry. Even in the best cultivated districts, while farms continue to be let to the highest responsible offerers, a few restrictive covenants cannot be dispensed with. The supposed interest of the tenant is too feeble a security for correct management, even during the earlier part of a lease; and in the latter part of it, it is thought to be his interest, in most cases, to exhaust the soil as much as possible, not only for the sake of immediate profit, but frequently in order to deter competitors, and thus to obtain a renewal of his lease at a rent somewhat less than the lands would otherwise bring. (*Sup. Encyc. Brit. art. Agr.*) In England the tenant is generally bound down by a mass of cumbrous and useless covenants, not only depriving him of the power of exercising all judgment, but often tying him to a course at variance with the interest of both the contracting parties. A few simple, but precise stipulations, will, for the most part, be sufficient to restrain the lessee from an injurious course of cultivation, and supersede the necessity of those vexatious covenants which are often too heedlessly imposed upon him. (*Quar. Jour. Agr.* vol. i. p. 798.)*

4699. *With tenants at will, and such as hold on short leases, restrictive covenants are more necessary than with tenants on leases of nineteen or twenty years; but in many instances, they are too numerous and complicated, and sometimes even inconsistent with the best courses of modern husbandry. The great error lies, in prescribing rules by which a tenant is positively required to act, not in prohibiting such practices and such crops as experience has not sanctioned. The improved knowledge, and the liberality of the age, have now expunged the most objectionable of these covenants; and throughout whole counties, almost the only restriction in reference to the course of crops is, that the tenant shall not take two culmiferous crops, ripening their seeds in close succession. This single stipulation, combined with the obligation to consume the straw upon the farm, and to apply to it all the manure made from its produce, is sufficient not only to protect the land from exhaustion, but to insure, in a great measure, its regular cultivation; for half the farm, at least, must, in this case, be always under either fallow or green crops. The only other necessary covenant, when the soil is naturally too weak for carrying annual crops without intermission, is, that a certain portion of the land shall be always in grass. According to the extent of this, will be the interval between the succession of corn crops on the same fields; if it be agreed that half the farm, for instance, shall always be under grass, there can be only two crops of corn from the same field in six years. In this case, not more than two sixths being in corn, one sixth in green crops or fallow, and three sixths in clover or grasses, it becomes almost impossible to exhaust any soil at all fitted for tillage. There are few indeed that do not gradually become more fertile under this course of cropping. It is sufficiently evident, that other covenants are necessary in particular circumstances; such as permission to dispose of straw, hay, and other crops from which manure is made, when a quantity of manure equal to what they would have furnished is got from other places; and a prohibition against converting rich old grazing lands or meadows into corn lands. In this place we speak only of general rules, such as are applicable to, perhaps, nine tenths of all the arable land of Britain, and such as are actually observed in our best cultivated counties.*

4700. *For the last four years of a lease, the same covenants are generally sufficient, only they require to be applied with more precision. Instead of taking for granted, that the proportion of the farm that cannot be under corn, will be properly cultivated, from the tenant's regard to his own interest, it becomes necessary to take him bound to this effect in express terms; the object generally being to enable the tenant, upon a new lease, to carry on the cultivation of the lands, as if the former lease had not terminated. What these additional stipulations should be, must depend in part on the season of the year at which the new lease commences, and in part on the course of crops best adapted to the soil, and the particular circumstances of every farm.*

4701. *With respect to the form of a lease, as no one form would suit every district, nothing specific can be laid down with advantage. The lawyers of every estate have particular forms, and it is easy for them, in concert with the proprietor or manager, to obliterate useless or injurious restrictions, and substitute such as may be deemed best for the estate, or in harmony with the progress of the age. (*Sup. Encyc. Brit. art. Agr.*)*

SUBJECT. 5. *Receiving Rents.*

4702. *The business of receiving the rents and profits of a landed estate, simple as it may seem, is subject to analysis, and entitled to consideration. Indeed, on large properties, on which not farm rents only, but various other profits, are to be received, as cottage rents, tithe compositions, chief rents, and, perhaps, quit rents of copyhold lands; the business becomes so complex as to require to be methodised and simplified, in order to obtain the requisite facility and despatch. This is generally best effected by appointing*

distinct days, or distinct parts of the day, for each receipt, so that the different tenants and suitors may know their hours of attendance.

4703. *The business of holding manor courts* depends on whether they are held of right, or merely by custom. If the copyhold tenure is so far worn out in any manor, that there are not two ancient or feudal tenants remaining within it, the court has lost its legal power; it cannot by right take cognizance of crimes, nor enforce amerciaments. Nevertheless, manorial courts have their uses, in regulating farm roads, driftways, and water-courses, and in preventing nuisances of different kinds within a manor; and it is generally right to preserve the custom of holding them for these purposes.

4704. *Where copyhold courts remain in force*, and where legal forms are to be observed, a law "steward of the manor" is proper to hold them. It is not necessary, however, that courts of this kind should interfere with the receipt of farm rents; or that a business of this nature should in any way clash with the general receivership of the estate. Employ an attorney to hold courts, as a surveyor to arbitrate disputes, or an engineer to plan works of improvement.

4705. *The propriety of having fixed days for receiving the rents of farms* is evident; and some consideration is required to determine on the season of the year for holding them, so as not to oblige the farmer to forced sales of his produce. In England and Ireland, farm rents are generally due at Lady-day and Michaelmas, and in Scotland at Candlemas and Lammas. But the proper times of paying them depend on the marketable produce of an estate, and on the season of the year at which it goes in common course, and with the best advantage, to market. A tenant should never be forced to sell his produce with disadvantage; nor, when he has received his money for it, ought he to be at a loss for an opportunity of discharging his debt to his landlord. On corn-farm estates, or those whose lands are kept in a state of mixed cultivation, which comprise the great mass of farm lands in this kingdom, Michaelmas may be considered as one of the worst times of the year, at which to call upon tenants for their rents. It is at the close (or, in the northern provinces, perhaps at the height) of harvest, when the farmers' pockets are drained by extra labour, and when they have not yet had time to thresh out their crops to replenish them; nor is the summer's grass at that season yet consumed, nor off-going stock, perhaps, yet ready for market. In Norfolk, Marshal found the end of February, or beginning of March, a very fit time to pay the half year's rent due at Michaelmas; and June for paying those due at Ladyday. In some districts of the north it used to be the custom not to demand the first half year's rent, till the tenant was a year in his farm, by which means he had the use during his lease of nearly a year's rent in addition to his actual capital. But farmers there being now considered as possessed of more wealth than formerly, the first half year's rent of the lease is paid nine months after possession, and the last half year's rent of the term on or immediately before its expiration.

4706. *The proper days for receiving rents* are to be determined by the local circumstances of an estate and the district in which it lies; more especially by the fairs of the neighbourhood at that season, and by other stated times at which the tenants are accustomed, in conformity with the practice of the country, to receive for their dairy produce or other articles delivered in to dealers; and should be fixed immediately after these days of embursement.

4707. *On the subject of arrears*, a good deal has been said by Marshal; but it is one of those which may very safely be left to the good sense and discretion of the proprietor or his manager.

SECT. III. *Keeping and Auditing Accounts.*

4708. *Clearness and brevity* constitute the excellence of accounts, and these excellencies are only to be obtained by simplicity of method. Where lands lie in detached estates so as to require different receivers, a separate account is necessarily required for each receivership; but to preserve this simplicity and clearness, it is necessary that the several sets should be in precisely the same form.

4709. *The groundwork of the accounts peculiar to a landed estate* is the rent-roll: from this receiving rentals are to be taken, and with these and the miscellaneous receipts and disbursements incident to the estate, an account current is to be annually made out.

4710. *In the receiving rental* the particulars which a receiver wants to see at one view, when receiving the rents of an estate under judicious management, where rents are regularly received, and where occupiers pay taxes and do ordinary repairs, are few; the name of the farm, the name of the tenant, and the amount of his half year's rent, only are required: but upon an estate, on which arrears are suffered to remain, and on which matters of account are liable to take place, a greater number of particulars are necessary; as the name of the farm, of the tenant, his arrears, his half year's rent, any other charge

against him, any allowance to be made him, and the nett sum receivable, leaving a blank for the sum received and another for the arrear left.

4711. *Accounts current* are required to be delivered in annually by the acting manager, who ought generally to be the receiver. If the current receipts and disbursements are numerous, as where extensive improvements are going on, and woods, mines, quarries, &c., in hand, such accounts may be given in monthly, which will show the progress of the several concerns, and simplify the business at the end of the year.

4712. *On the best managed estates* it is usual, besides the books which have been mentioned, to keep a ledger; opening separate accounts for farm lands, woods, mines, quarries, waters, houses and their appurtenances, public works, &c. : and where a proprietor has several detached estates, besides such accounts being kept on each, one master ledger contains accounts for the whole property. This, indeed, is nothing but an obvious application of mercantile book-keeping to territorial property, the advantages of which cannot but be as great in the one case as in the other.

4713. *In auditing estate accounts*, the rent accounts are to be checked with the arrears of the preceding year; the column of rents with the rent-roll, corrected up to the last term of entry in order to comprise the fresh lettings; and the columns of account with the particulars, those of allowances being signed by the respective tenants.

4714. *The monthly accounts of receipts and disbursements*, as well as the annual payments, are to be compared with vouchers. The receipts are checked by deeds of sale, contracts, and other written agreements, the awards of referees, or the estimates of surveyors, the market prices of produce, &c. ; the receiver, in every case, identifying the person from whom each sum was received. Each disbursement requires a direct and sufficient voucher, endorsed and numbered, with a corresponding number affixed to the charge in the account, so that they may be readily compared.

4715. *The most essential part of the office of an auditor* is that of entering into the merits of each receipt and payment; and considering whether the charges correspond with the purposes for which they are made; and whether the several sums received are adequate to the respective matters disposed of; by these means detecting, and thenceforward preventing, imposition and connivance. This, however, is an office which no one but a proprietor, or other person, who has been conversant with the transactions that have taken place upon the estate, and who has a competent knowledge of rural concerns, can properly perform. It may therefore be right to repeat, that if a proprietor has not yet acquired a competent knowledge of his own territorial concerns, to form an adequate judgment of the different entries in his manager's account, he should call in the assistance of those who are conversant in rural affairs, to enable him to judge of any particular parts that may seem to require it; and should not set his hand to an account which he does not clearly understand, nor authorise another to sign it, who may have less knowledge than himself of its merits.

BOOK V.

SELECTION, HIRING, AND STOCKING OF FARMS.

4716. *FARMS or lands let out to men who cultivate it as a business or profession* exist in all highly civilised countries. Sometimes the farmer or tenant pays to the proprietor or landlord a proportion of the produce, determined yearly, or as the crops ripen; and sometimes he pays a fixed quantity of produce, or labour, or money, or part of each of these. In Britain, where farming, as a profession, is carried to a higher degree of perfection than in any other country, the connection between landlord and tenant is regularly defined by particular agreements and general laws; and the latter, on entering on a farm, engages to pay a fixed sum for its use for a certain number of years. This sum is fixed according to the estimated value of the land; but being fixed, and for a certain time, it admits of no abatement in proportion to the quantity or value of the produce, as in the proportional or metayer system general in most countries (265. and 596.); and hence the necessity of a farmer maturely considering every circumstance connected with a farm before he becomes its tenant. The subjects of consideration form the business of this Book, and naturally divide themselves into such as relate to the farm, to the farmer, and to the landlord. Some of the subjects, being treated of in the preceding Book, will be but slightly noticed, though, as connected with the object of the present, they could not be altogether omitted.

CHAP. I.

Circumstances of a Farm necessary to be considered by a proposed Tenant.

4717. *Whoever intends to become a professional or rent-paying farmer will, in searching for a farm, find it necessary to attend to a great variety of considerations. Those of the greatest importance may be included under climate, soil, and subsoil, character of surface, topographical position, extent, buildings, roads, fields, tenure, rent, and outgoings. In The Code of Agriculture, a more valuable collection of facts as to these points is brought together than in any other work, and from it, therefore, we shall select the greater part of the following sections.*

SECT. I. *Climate, in respect to farming Lands.*

4718. *The climate of a farm is one of the circumstances over which human art has less control than over any other; and a farmer who has but a temporary interest in his possession may be considered as incapable of exercising any influence over it. He may improve the soil and subsoil by draining and culture; and the buildings, roads, and fences by additions and alterations; but it is for the landlord to attempt improving the climate by planting, and for a future generation to enjoy the effects.*

4719. *Sufficient attention, it is said in The Code of Agriculture, "is rarely paid by the farmer to the nature of the climate in which his operations are carried on. Unless the system he adopts be calculated for the weather his crops are likely to experience, every exertion will often terminate in disappointment. The system that is proper for warm and dry situations is not suitable for cold and wet ones; and in a bleak and backward climate, the nature of the soil ought not only to be attended to, but the utmost care ought to be paid to the early sowing of the earliest varieties of seed. Even the species of stock to be bred or kept on a farm should, in a great measure, be regulated by the climate. Hence, this is a subject which the diligent farmer will invariably study with the greatest solicitude. Climate and soil, Curwen justly remarks, are, above all other considerations, those which the farmer ought constantly to keep in view." (Report to the Workington Society.)*

4720. *In considering the climate of a country, the following points are of peculiar importance: — Its general character, and the means of its improvement; its local heat; the light it furnishes; the quantity of its moisture; the prevailing winds; its position, whether maritime or inland; the regularity of the seasons; the phenomena to which it is liable; the productions best suited to it; the expenses it may occasion in cultivation; and its suitableness for the introduction of exotic plants and animals.*

4721. *The general character of a climate not only depends on position or latitude, but likewise on the elevation of a country above the level of the sea; its general aspect; the vicinity to mountains, forests, bogs, marshes, lakes, and seas; the nature of the soil and subsoil, and the power which the former possesses of retaining heat and moisture; the direction of the winds; the length of time the sun continues above the horizon; the difference of temperature between the day and the night; and the extent of dry surface in the neighbourhood. The result of these particulars combined form what may be called the general character of climate. Some of the causes of an unfavourable climate cannot be remedied by any human effort; in other cases, art may effect much; but that art is generally such as the farmer can seldom undertake, unless with a very long lease. Ameliorations of this sort, therefore, belong to the landlord.*

4722. *The importance of heat, as a stimulus to vegetation, cannot be doubted. It is at a certain degree of heat that vegetation commences, and it becomes nearly stationary when the temperature falls below it. There are, comparatively speaking, but few plants calculated for very cold countries, and these are seldom valuable; whereas, in warm and temperate regions, the variety is great, and their value unquestionable. Indeed, such is the effect of cold, that, while the thermometer is below forty degrees of heat, the strongest plants become torpid, and remain in that state while it continues. Revived by the warmth of spring, and strengthened by the heat of summer, they acquire fresh life and vigour, and are thus better enabled to withstand the rigours of the succeeding winter.*

4723. *An increased temperature, when not carried to excess, will augment the quantity of nutritive matter in a plant, or improve the quality of fruit grown under its influence. Thus, English barley, of equal weight, is more valuable than the Scotch, because, from growing in a warmer climate, and enjoying the advantage of a greater quantity of heat and light, it is more fully ripened. It thence acquires more saccharine matter, and produces a greater quantity of spirits, or of malt liquor. It is also proved, by the experiments of Sir Humphry Davy, that wheat, ripened in a more regular and warmer climate, contains more of that valuable article called gluten, than the same species of grain when raised in England.*

4724. *The average heat of the year is not, however, of so much importance to the growth of plants, as its duration, and its steadiness at a certain degree, during the season when the grain is ripening. This gives the uniform climates of the Continent a great advantage over our variable seasons, in the production of the more delicate sorts of fruit; which, in this island, are often injured by the frosts in spring, and seldom ripen in a northern climate, where the greatest summer heat is both unsteady and of short duration.*

4725. *The quantity of solar light which a climate furnishes, is likewise an important object of enquiry. Light is essential to increase the proportion of starch or farina; to complete the formation of oils in plants; and to give to fruits their proper colour and flavour. It has also the effect of augmenting saccharine matter, insomuch that those sugar-canes which are exposed to the sun have more of that important ingredient than when they grow under shade. Nor ought the observation to be omitted, that darkness and light have effects directly opposite upon vegetables. Darkness favours the length of the growth, by keeping up the pliancy of their parts; light consolidates them, and stops growth, by favouring maturation. Hence, in the northernmost regions, plants go through all their stages of growth at a time when the sun no longer quits the horizon; and the light, of which they thus experience the unremitting effect, hardens them before they have time to lengthen. Their growth is therefore quick, but of short duration. They are robust, but undersized. (Mirbel.) It has been remarked also, that a soil, not rcten-*

tive, will be more productive in a wet climate than in a dry one. Hence, in the western coasts of England, as in Lancashire, where the quantity of rain that falls annually varies from forty to sixty inches, a siliceous sandy soil is much more productive than the same species of soil in the eastern districts, where seldom more than from twenty-five to thirty-five inches of rain fall in a year. In wet climates, also, even wheat and beans will require a less coherent and absorbent soil than in drier situations. At the same time, weather moderately dry is the most favourable to a great produce of corn; and the blossoms of wheat, in particular, set best if no rain falls in the flowering season.

4726. *The importance of moisture to vegetation* is obvious to every one. Water constitutes a large proportion of every plant, and is the vehicle of the food of plants held in solution. Hence, without so essential an ingredient, they must either become stunted in their growth or perish. In dry weather, when vegetation seems at a stand, no sooner do showers of rain fall, than a rapid growth of every kind of herbage immediately succeeds, even on poor dry soils, where otherwise, however well manured, vegetation would make but slow progress.

4727. *The quantity of rain that falls annually in any country* is a very inferior consideration, when compared with that of the general and equable distribution of that quantity throughout the several days and months of the year. A great quantity, at the same time, is rather hurtful than beneficial; whereas those moderate, but golden showers, which regularly fall on a soil calculated to receive them, are real sources of fertility. It is by this that the character of a climate, whether wet or dry, is chiefly determined, and the operations of agriculture are principally influenced.

4728. *The utility of a moist atmosphere, with a view to vegetation*, is, in some respects, peculiarly remarkable. Thus, in wet climates, as on the western coasts of England, Scotland, and Ireland, crops of grain and potatoes are found to exhaust the soil less than in dry situations. Oats in particular are impoverishing in a greater degree in dry climates, than in moist ones; and in the former, should be sown much earlier than in the latter.

4729. *The disadvantages of a wet climate to a farmer*, more especially if accompanied with a retentive soil, are very great. It is calculated, that in the richest district in Scotland, the Carse of Gowrie, there are only about twenty weeks in the year fit for ploughing; whereas in several parts of England, they have thirty weeks, and in many cases more, during which this essential operation can be performed. Hence ploughing must be much more expensive in the one case than in the other.

4730. *The season of the year in which rain abounds* is likewise of much importance. An excess is prejudicial in any season, but is peculiarly so in autumn, when it often lodges the grain by its violence, or by its long continuance prevents the corn from being properly harvested. The hopes of the husbandman are thus blasted, and the fruits of his toil and industry are frequently diminished, and sometimes entirely lost.

4731. *Dews have a great effect in furnishing plants with moisture*; and, indeed, without their aid, vegetation, in warm and dry climates, could not go on. Even in temperate regions dews are beneficial. In Guernsey, on the coast of Normandy, the autumnal dews are singularly heavy, so much so that, in the middle of a hot day, the dew-drops are not quite exhaled from the grass. From this moisture the after-grass receives great benefit. Dr. Hales estimated the quantity of dew that falls in one year at three and a half inches; Dalton, at nearly five inches. In this matter, however, it is not easy to be correct.

4732. *The prevailing winds* have a great influence on the character of a climate, and a powerful effect on vegetation. When they pass over a large expanse of water, they are usually of a warmer or higher temperature in winter, than those which blow over high lands; more especially if such come from countries covered with snow. Hence the east and north-east winds, which have passed over the coldest regions of Europe, are much colder than the west and south-west winds, which blow over the Atlantic Ocean, and they oftener occasion blights. The former are comparatively drier, unless when accompanied by those thick mists, called haars, arising from the copious evaporation of the German Ocean. The latter are loaded with the vapours of the Atlantic, and often, from excess of moisture, are rendered prejudicial. The strength of the prevailing winds, or the violence with which they act, more especially during harvest, ought likewise to be considered. If they are very violent, they are apt to affect the crops, and of course it becomes an object to suit the produce to them; and to form fences, enclosures, and plantations accordingly.

4733. *A maritime position* occasions a more equal temperature in a climate. Where a great body of land is exposed to the heating rays of the sun, the air becomes much warmer than it would if resting upon a small body of land, contiguous to, or surrounded by, the ocean. On the other hand, as the sea always preserves nearly the same temperature, and, except in the most northern regions, is never frozen, it communicates warmth, in the cold seasons of the year, to the air passing over it, which had been cooled in its passage over continents covered with ice and snow. Hence islands are more temperate than continents. It appears, indeed, that the thermometer has not so great a range on the sea coast, as in the more inland parts of Great Britain, even at an elevation of 400 feet above the level of the sea. Of the influence of proximity to the sea many proofs might be brought forward. It is in consequence of this circumstance, that the city of Moscow, which is situated somewhat farther south than Edinburgh, experiences winters much more severe. Another effect of a maritime position is, that strong winds which blow from the sea are sometimes accompanied by salt spray or vapour, which is injurious to crops of grain, and the leaves of trees; but when it comes in moderation, those saline particles, with which the westerly winds are loaded, contribute to the verdure of the fields in pasture.

4734. *The nature of the inland position* is also of much importance. The relative position of the neighbouring hills occasions a material difference of climate, exposing some districts to great severity of weather, and, by protecting others from that disadvantage, greatly promoting their fertility.

4735. *In many countries the seasons are regular*. In others, as in Great Britain, they are extremely variable, and often change, in the space of a few hours, from dry to moist, from hot to cold, from clear to cloudy, and from a pleasant serenity to all the violence of a tempest. But such irregularities of climate, however uncomfortable, are often favourable to vegetation, and compensated by the advantages they produce. It is not in countries where the seasons of heat and cold, wind and rain, are periodical, or where the greatest regularity of climate takes place, that mankind are the most healthy or vigorous, or the useful productions of the soil most perfect. Perhaps a sameness of climate, as well as of other things, is prejudicial rather than useful. Where a climate is inconstant, the air is refined and purified by the frequent changes it undergoes; and the disadvantages which originate from that source are often counteracted, or at least essentially mitigated, by judicious management, and persevering exertions.

4736. *The climate of a country is likewise affected* by atmospherical and natural phenomena; by earthquakes, volcanos, violent thunder storms, lightning, hail storms in summer, early frosts, whirlwinds and hurricanes, water-spouts, and by that atmospherical appearance, known under the name of the aurora borealis, so frequently to be seen in northern, and sometimes even in southern, regions; but these phenomena, for the most part only occasional, sometimes prevent greater calamities, and, in this country, are rarely attended with permanent evils.

4737. *Frosts late in spring* are highly injurious to the blossoms of fruit trees; and autumnal frosts creep along the banks of rivers, destroying the corn in the flowering season, and blasting the stems of potatoes in low situations. Winter frosts are ultimately rather favourable to vegetation; and snow, particularly when it covers the ground for some time, and gradually melts away.

4738. *The size, and, in many cases, the value, of the productions of a country, depend upon its climate*, by whose influence their growth may either be advanced or retarded. The same species of tree, which, in a temperate climate, will rise to a great height, and swell to an immense size, in an exposed situation will remain small and stunted. By a favourable climate, also, the most barren spots, which in a cold country

must remain completely waste, in a warm one may be rendered productive. Thus, where the climate is adapted to the culture of the vine, rocks, which in Great Britain, and in colder countries, would in general be of little or no worth, in the southern provinces of France may yield as much in valuable produce as the cultivated land in their neighbourhood. The real excellence of a climate, however, depends on its yielding, in perfection and abundance, the necessaries of life, or those which constitute the principal articles of food for man, and for the domestic animals kept for his use. In this point of view, a meadow is much more productive, and in some respects more valuable, than either a vineyard or a grove of oranges; though the one may be situated in a cold and variable climate, and the other in a country celebrated both for its regularity and warmth of temperature.

4739. *Even the nature of the articles raised depends upon the climate.* Thus, in many elevated parts, both of England and Scotland, wheat cannot be grown to advantage, and in some of the high-lying districts of the latter, it has never been attempted. In several of the northern counties, it has been found necessary to sow, instead of the two-rowed barley, the inferior sort called bear or big; and oats, from the hardy quality of the grain, are found to be a more certain and more profitable species of corn than any other; while in humid districts peas or beans cannot be safely cultivated, from the periodical wetness of the autumn. On the whole, without great attention to the nature of the climate, no profitable system can be laid down by any occupier of land.

4740. *An inferior climate greatly augments the expenses of cultivation;* because a number of horses are required for labour during the short period of the year, when the weather will admit of it, which, at other seasons, are a useless burden upon the farm. When to this are joined an uneven surface and an inferior quality of soil, arable land is of little value, and yields but a trifling rent.

4741. *Exotic plants or animals can only be naturalised in climates with success by paying attention to that whence they were brought, and by endeavouring either to render the one as similar to the other as circumstances will admit of, or to counteract, by judicious management, the deficiencies of the new one.*

4742. *In order to ascertain the nature of a climate, the farmer, in modern times, has many advantages which his predecessors wished for in vain.* The progress of science has given rise to many new instruments, which ascertain natural phenomena with a considerable degree of accuracy. It may still be proper to study the appearance of the heavens, and not to despise old proverbs, which often contain much local truth; but the vane now points out the quarters whence the winds blow, with all their variations; the barometer often enables us to foretel the state of the weather that may be expected; the thermometer ascertains the degree of heat; the hygrometer, the degree of moisture; the pluviometer, or rain-gauge, the quantity of rain that has fallen during any given period; and, by keeping exact registers of all these particulars, much useful information may be derived. The influence of different degrees of temperature and humidity, occurring at different times, may likewise be observed, by comparing the leafing, flowering, and after-progress of the most common sorts of trees and plants, in different seasons, with the period when the several crops of grain are sown and reaped each year.

SECT. II. Soil in respect to farming Lands.

4743. *The necessity of paying attention to the nature and quality of the soil need not be dwelt upon.* By ascertaining the qualities it possesses, or by removing its defects, the profits of a farmer may be greatly increased. He must, in general, regulate his measures accordingly, in regard to the rent he is to offer; the capital he is to lay out; the stock he is to keep; the crops he is to raise; and the improvements he is to execute. Indeed, such is the importance of the soil, and the necessity of adapting his system to its peculiar properties, that no general system of cultivation can be laid down, unless all the circumstances regarding the nature and situation of the soil and subsoil be known; and such is the force of habit, that it rarely happens that a farmer who has been long accustomed to one species of soil will be equally successful in the management of another. From inattention to the nature of soils, many foolish, fruitless, and expensive attempts have been made to introduce different kinds of plants, not at all suited to them; and manures have often been improperly applied. This ignorance has likewise prevented many from employing the means of improvement, though the expense was trifling, and within their reach. From ignorance also of the means calculated for the proper cultivation of the different soils, many unsuccessful and pernicious practices have been adopted. Soils may be considered under the following general heads: — Sandy; gravelly; clayey; stoney; chalky; peaty; alluvial; and loamy, or that species of artificial soil into which the others are generally brought by the effects of manure, and of earthy applications, in the course of long cultivation.

4744. *Though sandy soils are not naturally valuable, yet being easily cultivated, and well calculated for sheep, that most profitable species of stock, they are often farmed with considerable advantage; and when of a good quality, and under a regular course of husbandry, they are invaluable.* They are easily worked, and at all seasons; they are cultivated at a moderate expense; are not so liable to injury from the vicissitudes of the weather; and in general they are deep and retentive of moisture, which secures excellent crops even in the driest summers. The crops raised on sandy soils are numerous, such as turnips, potatoes, carrots, barley, rye, buck-wheat, peas, clover, saintfoin, and other grasses. This species of soil, in general, has not strength enough for the production of Swedish turnips, beans, wheat, flax, or hemp, in any degree of perfection, without much improvement in its texture, the addition of great quantities of enriching manure, and the most skilful management. In Norfolk and Suffolk it is found, that poor sandy soils, unfit for any other purpose, will, under saintfoin, produce, after the first year, about two tons per acre of excellent hay, for several years; with an after-grass, extremely valuable for weaning and keeping lambs. How much more beneficial than any crops of grain that such soils usually yield! (*Young's Kalend.* 123.)

4745. *The fertility of sandy soils is in proportion to the quantity of rain that falls, combined with the frequency of its recurrence.* As a proof of this, in the rainy climate of Turin, the most prolific soil has from seventy-seven to eighty per cent. of siliceous earth, and from nine to fourteen of calcareous; whereas in the neighbourhood of Paris, where there is much less rain, the silex is only in the proportion of from twenty-six to fifty per cent. in the most fertile parts.

4746. *Gravelly soils differ materially from sandy, both in their texture and modes of management.* They are frequently composed of small soft stones, sometimes of flinty ones; but they often contain granite, limestone, and other rocky substances, partially, but not very minutely decomposed. Gravel, being more porous than even sand, is generally a poor, and what is called, a hungry soil, more especially when the parts of which it consists are hard in substance, and rounded in form. Gravelly soils are easily exhausted; for the animal and vegetable matters they contain, not being thoroughly incorporated with the earthy constituent parts of the soil (which are seldom sufficiently abundant for that purpose), are more liable to be decomposed by the action of the atmosphere, and carried off by water.

4747. *A gravelly soil*, free from stagnant water, gives such an additional warmth to the climate, that vegetation is nearly a fortnight earlier than where other soils predominate. About Dartford and Blackheath, in Kent, such soils produce early green peas, winter tares, rye, autumnal peas, and occasionally wheat, in great perfection.

4748. *Gravelly soils, in a wet climate*, answer well for potatoes; in Cornwall, in a sheltered situation, with a command of sea-sand, and of sea-weed, they raise two crops of potatoes in the same year.

4749. *Poor gravelly soils full of springs*, and those sulphureous, are very unfriendly to vegetation; and are better calculated for wood than for arable culture.

4750. *The stony, shaley, or stone-brash soils* of Gloucestershire, and the midland counties of England, are much mixed with small stones, but have more frequently sand, or clay, or calcareous loam, in their composition than gravelly soils, and are therefore generally preferable.

4751. *A clayey soil* is often of so adhesive a nature that it will hold water like a dish. In a dry summer, the plough turns it up in great clods, scarcely to be broken or separated by the heaviest roller. It requires, therefore, much labour to put it in a state fit for producing either corn or grass, and it can only be cultivated when in a particular state, and in favourable weather. Though it will yield great crops under a proper system of management, yet, being cultivated at a heavy expense, requiring stronger instruments and stouter horses, it is seldom that much profit is obtained, unless when occupied by a judicious and attentive farmer. The best management of clay soils is that of the Lothians. There they are found well calculated for growing crops of beans, wheat, oats, clover, and winter tares: but are not adapted for barley, unless immediately after a fallow; nor for potatoes, unless under very peculiar management. In regard to turnips, they do not usually thrive so well in clays, as in soils which are more free and open: but it is now ascertained, that the Swedish, and above all the yellow, turnip may be raised in them with advantage; that the quality is superior; that if they are taken up early, the soil is not injured; and that there is no difficulty in preserving them. Clays become good meadow-lands, and answer well for hay, or soiling, when in grass; but from their aptitude to be poached, they are, in general, unfit to be fed by heavy cattle in wet weather. In dry seasons the after-grass may be used to feed neat cattle till October, and sheep till March. A stiff clay, when not cold or wet, with a strong marl under it, is preferred in Cheshire and Derbyshire for the dairy.

4752. *On reclaimed peat-bogs*, oats, rye, beans, potatoes, turnips, carrots, cole-seed, and white and red clover, may be cultivated. Wheat and barley have succeeded on such lands, after they have been supplied with abundance of calcareous earth; and the fiorin grass (*Agróstis stolonifera*) seems likewise to be well adapted to that description of soil in a warm climate. In Leicestershire, and other counties, they have great tracts of meadow-land; these are, in many instances, the sites of lakes filled up, and the soil is composed of peat and sediment; the peat originally formed by aquatic vegetation, and the sediment brought down by rains and streams from the upland. This soil is admirably calculated for grass.

4753. *The fens* in Cambridgeshire, Lincolnshire, and several other districts in England, consist of peat and sediment.

4754. *Chalky soils* principally consist of calcareous matter mixed with various substances, in greater or less proportions. Where clayey or earthy substances are to be found in such soils in considerable quantities, the composition is heavy and productive; where sand or gravel abounds, it is slight, and rather unfruitful. The crops chiefly cultivated on chalky soils are peas, turnips, barley, clover, and wheat; and, however much the soil is exhausted, it will produce saintfoin.

4755. *Chalky soils are in general fitter for tillage than for grazing*; for, without the plough, the peculiar advantages derived from this soil by saintfoin could not be obtained. The plough, however, ought not to extend to those fine chalky downs (called ewe leases in Dorsetshire), which, by a very attentive management during a number of years, have been brought to a considerable degree of fertility as grazing land, and which are so useful to sheep in the winter season. A chalky soil that has been in tillage permits water to pass through it so freely in winter, and is so pervious to the sun's rays in summer, that it is the work of an age to make it a good pasture of natural grasses, more especially when the chalk lies near the surface. Hence, in the western counties of England, several thousands of acres of this soil, though not ploughed for thirty years, have scarcely any grass of tolerable quality upon them, and are literally worth nothing. Such soils ought to be laid down with saintfoin.

4756. *Alluvial soils* are of two sorts; one derived from the sediment of fresh, and the other from that of salt water. Along the sides of rivers, and other considerable streams, water-formed soils are to be met with, consisting of the decomposed matter of decayed vegetables, with the sediment of streams. They are in general deep and fertile, and not apt to be injured by rain, as they usually lie on a bed of open gravel. They are commonly employed as meadows, from the hazard of crops of grain being injured or carried off by floods.

4757. *Alluvial soils, arising from the operations of salt water*, called salt marshes in England, corses in Scotland, and polders in Holland and Flanders, are composed of the finest parts of natural clay, washed off by running water, and deposited on flat ground, on the shores of estuaries, where they are formed by the reflux of the tide, and enriched with marine productions. They generally have a rich level surface, and being deep in the staple, they are well adapted for the culture of the most valuable crops. Hence wheat, barley, oats, and clover are all of them productive on this species of soil; which is likewise peculiarly well calculated for beans, as the tap-root pushes vigorously through it, and finds its nourishment at a great depth. From the great mass of excellent soil, the fertility of these tracts is nearly inexhaustible; but, from their low and damp situations, they are not easily managed. Lime, in considerable quantities, is found to answer well upon this species of soil.

4758. *The term loamy soil* is applied to such as are moderately cohesive, less tenacious than clay, and more so than sand. Loams are the most desirable of all soils to occupy. They are friable; can in general be cultivated at almost any season of the year; are ploughed with greater facility, and less strength than clay; bear better the vicissitudes of the seasons; and seldom require any change in the rotation adopted. Above all, they are peculiarly well adapted for the convertible husbandry; for they can be changed, not only without injury, but generally with benefit, from grass to tillage, and from tillage to grass.

4759. *As to the comparative value of soil*, it has been justly remarked, that too much can hardly be paid for a good soil, and that even a low rent will not make a poor one profitable. The labour of cultivating a rich and a poor soil is nearly the same; while the latter requires more manure, and consequently is more expensive. Poor soils, at the same time, may have such a command of lasting manures, as lime or marl, or even of temporary sorts, like sea-weed, or the refuse of fish, as may render them profitable to cultivate. It is a wise maxim in husbandry, that the soil, like the cattle by which it is cultivated, should always be kept up in good condition, and never suffered to fall below the work it may be expected to perform.

SECT. III. *Subsoil relatively to the Choice of a Farm.*

4760. *On the nature of the under-stratum* depends much of the value of the surface soil. On various accounts its properties merit particular attention. By examining the

subsoil, information may be obtained in regard to the soil itself; for the materials of the latter are often similar to those which enter largely into the composition of the former, though the substances in the soil are necessarily altered, by various mixtures, in the course of cultivation. The subsoil may be of use to the soil, by supplying its deficiencies and correcting its defects. The hazard and expense of cultivating the surface are often considerably augmented by defects in the under-stratum, but which, in some cases, may be remedied. Disorders in the roots of plants are generally owing to a wet or noxious subsoil. Subsoils are retentive or porous.

4761. *Retentive subsoils* consist of clay, or marl, or of stone beds of various kinds. A retentive clayey subsoil is in general found to be highly injurious. The surface soil is soaked with water, is ploughed with difficulty, and is usually in a bad condition for the exertion of its vegetative powers, until the cold sluggish moisture of the winter be exhaled. By the water being retained in the upper soil, the putrefactive process is interrupted, and manures are restrained from operating, consequently the plants make but little progress. Hence, its grain is of inferior quality, and when in grass its herbage is coarse.

4762. *A stony subsoil*, when in a position approaching to the horizontal, is in general prejudicial, and, if the surface-soil be thin, usually occasions barrenness, unless the rock should be limestone; and then the soil, though thin, can easily be converted into healthy pastures, and, in favourable seasons, will feed a heavy stock. They will also produce good crops of corn, though subject to the wire-worm. They also produce good crops of corn, though subject to the wire-worm.

4763. *A porous subsoil* is uniformly attended with this advantage, that by its means all superfluous moisture may be absorbed. Below clay, and all the variety of loams, an open subsoil is particularly desirable. It is favourable to all the operations of husbandry; it tends to correct the imperfections of too great a degree of absorbent power in the soil above; it promotes the beneficial effects of manures; it contributes to the preservation and growth of the seeds; and ensures the future prosperity of the plants. Hence it is, that a thinner soil, with a favourable subsoil, will produce better crops than a more fertile one incumbent on wet clay, or on cold and non-absorbent rock. Lands whose substratum consists of clean gravel or sand can bear little sun, owing to their not having the capacity of retaining moisture, and their generally possessing only a shallow surface of vegetable mould. In England this soil was formerly called rye-land, being more generally cropped with that species of grain than any other. When such soils are cultivated for barley, they should be sown early and thick, with seed soaked forty-eight hours in water or in the exudation from a dung-heap. Thus its simultaneous germination and its simultaneous ripening may be secured.

SECT. IV. *Elevation of Lands relatively to Farming.*

4764. *The elevation of lands above the level of the sea* has a material influence on the kind and quality of their produce. Land in the same parallel of latitude, other circumstance being nearly similar, is always more valuable in proportion to the comparative lowness of its situation.

4765. *In the higher districts* the herbage is less succulent and nourishing, and the reproduction slower when the land is in grass; while the grain is less plump, runs more to straw, is less perfectly ripened, and the harvest is also later when the produce is corn. It has been calculated that in Great Britain sixty yards of elevation in the land are equal to a degree of latitude; or, in other words, that sixty yards perpendicularly higher, are, in respect of climate, equal to a degree more to the north. In considering the crops to be raised in any particular farm, attention ought therefore to be paid to its height above the level of the sea, as well as to its latitude. In latitude 54° and 55°, an elevation of 500 feet above that level is the greatest height at which wheat can be cultivated with any probable chance of profit; and even there the grain will prove very light, and will often be a month later in ripening than if sown at the foot of the hills.

4766. *The usual maximum of elevation* may be reckoned between 600 and 800 feet for the more common sorts of grain; and in backward seasons the produce will be of small value, and sometimes will yield nothing but straw. It is proper, at the same time, to remark, that in the second class of mountains in the county of Wicklow, in Ireland, where no other grain is considered to be a safe crop, rye is cultivated with success. Where the soil is calcareous, however, as on the Gloucestershire and Yorkshire wolds, from the superior warmth of that species of soil, compared to cold clays or peat, barley grows in great perfection at an elevation of 800 feet above the level of the sea. Some experiments have been made to raise corn crops, at even a higher elevation, on the celebrated mountain Skiddaw, in Cumberland, but unsuccessfully.

4767. *The greatest height at which corn will grow*, in the more remote parts of Scotland, so as to yield any profit to the husbandman, is stated to be at 500 feet above the level of the sea. At the same time corn has been produced, in other districts of that country, at still higher elevations, in particular at the following places:—

	<i>Feet above the Level of the Sea.</i>		<i>Feet above the Level of the Sea.</i>
Parish of Hume, in Roxburghshire	- 600	Doubruch, in Braemar, Aberdeenshire	1294
Upper Ward of Lanarkshire	- 760	Lead-hills, in Lanarkshire	- - - 1564

4768. *These and other instances* of land being cultivated on high elevations, however, are merely small spots, richly manured, and, after all, producing nothing but crops of inferior barley and oats, and seldom fully ripe or successfully harvested. It is chiefly where the soil is sandy or gravelly, that corn will answer in Scotland on such elevated situations; and even then, only when the seasons are propitious, and when there are local advantages, favourable to warmth and shelter, in the situation of the lands.

SECT. V. *Character of Surface in regard to farming Lands.*

4769. *A hilly irregular surface*, whether at a high or low elevation above the sea, is unfavourable to farming. The labour of ploughing, carrying home produce, and carrying out manure, is greatly increased; while the soil on the summit of steep hills, mounts, or declivities, is unavoidably deteriorated. On the sides of slopes the finer parts of the clay and mould are washed away, while the sand and gravel remain. Hence the soil in such

districts often wants a proper degree of tenacity for supporting corn crops. A great part of the manure that is applied in such situations is likewise soon lost. From various causes, also, they are colder than the plains.

4770. *Many extensive countries have no perceptible rise.* These have their advantages from uniformity of soil, where it is rich. In other districts, the surface is of a waving description, an inequality which contributes much to the ornament of the country, by the agreeable relief which the eye constantly meets with in the change of objects; while the universal declivity which prevails more or less in every field is favourable to the culture of the land, by allowing a ready descent to any water with which the surface may be encumbered.

SECT. VI. *Aspect in regard to farming Lands.*

4771. *Aspect, in hilly or mountainous districts,* is an important subject of attention to the farmer; more especially where the climate is unfavourable. It is proved in a variety of instances, both in the central highlands of Scotland, and in other parts of the kingdom, that where the aspect of a hill is towards the north, the soil is more fertile than when it lies with a southern exposure. This is attributed to the variations from frost to thaw in the spring months, which are greater in a southern than in a northern aspect. Hence, while the soil to the north remains locked fast, and secured from waste, the other is loosened by the sun, and carried off by showers falling in the intervals of thaw.

4772. *Soils which face the south* are more liable to have their substance carried away by heavy rains, which are generally impelled from the south and south-west. But though the soil to the north often produces the heaviest crops of grass and hay, yet from possessing a more genial climate, and from the earlier and more powerful action of the sun, both corn and grass are harvested earlier on land which has a southern than on that which has a northern aspect; and superiority of quality thus compensates for any inferiority in the quantity of the produce.

SECT. VII. *Situation of Farm Lands in regard to Markets.*

4773. *No farming can go on without markets.* The system of farming to be adopted on any particular farm, and the expense attending it, must materially depend on its situation in regard to markets; to the facility with which its produce can be conveyed, where a contiguous market is wanting; to vicinity to manure, to fuel, and to water.

4774. *The advantages resulting from vicinity to a market,* or to a large town, by which that is insured, are very great. Some crops, as those of potatoes, turnips, and clover, are frequently sold on the ground, without any farther trouble or expense to the farmer; and great quantities of manure may be purchased at a moderate expense. In such situations also there is a ready sale for every article the farm can produce; and the articles sold are not only brought to market at a small expense, but the payment is immediate. For all these reasons, it is contended, and apparently with justice, that the neighbourhood of a capital is the most profitable spot to farm in, notwithstanding the high rent of land, and the great expense of labour.

4775. *Where markets are not at hand,* the farmer ought to take into consideration what articles will best suit those at a distance to which his produce must be sent. In such a situation, unless there are facilities for the conveyance of so bulky an article as corn by good roads, or by water-carriage, it is advisable, instead of cultivating grain, to attend either to the dairy husbandry, or to the breeding of stock which can be fattened in other districts where good markets are more numerous. This plan, by which the dairy, the breeding, and the fattening of stock, are made distinct professions, is highly beneficial to the country at large. Stock can be reared cheaper in remote districts than where land is dear and labour high. On the other hand, the purchaser of lean stock avoids the expense and risk of breeding great numbers of animals. His attention is not distracted by a multiplicity of objects; he can alter his system from cattle to sheep, or from sheep to cattle, as is likely to be most profitable; his business is simplified, and the capital he lays out is speedily returned. The division of professions between breeding and feeding (though they may be united in circumstances peculiarly favourable), is on the whole a most important link in the progress of agricultural prosperity.

4776. *In regard to facility of conveyance,* the state of public roads, bridges, iron rail-ways, canals, rivers rendered navigable, and harbours, deserves the consideration of the farmer, and will most materially influence the value of produce.

4777. *The situation of the farm in regard to manures,* for an easy access to lime, chalk, marl, sea-weed, &c. is of essential advantage to cultivation. The price at which these articles can be purchased, their quality, their distance, and expense of conveyance, are likewise of importance. Farms, for example, possessing the advantage of sea-weed contiguous and in abundance, can pay from fifteen to twenty per cent. more rent per acre than otherwise could be afforded.

4778. *Vicinity to fuel* in the cold and moist regions of Europe are important considerations to the farmer. In the same county, even in England, the difference of expense is often material. In the Hebrides, from the moistness of the climate, the expense of fuel is reckoned equal to a third part of the rent of the land; and farmers who pay, in some cases, 150*l.* per annum, would give 200*l.* if the landlord would supply them and their servants with fuel.

4779. *Where a farmer is under the necessity of using peat,* from the labour attending the cutting, spreading, drying, and conveying it from a distance, several weeks of his horses and servants are devoted to that sole purpose; and much valuable time is lost, which ought to have been employed in the cultivation of his farm. It has been well remarked, that many farmers, to save five guineas on coal, often expend twenty, in thus misapplying the labour of their horses.

4780. *Where wood is used,* it occupies a great deal of ground that might often be cultivated to advantage, and it is not of a lasting quality. Coal is preferable, for general purposes, to every other species of fuel; and besides its domestic application, its superiority for burning lime, that important source of fertility, or calcareous clay, also of much value to the farmer, is an object of great moment. The tenant, therefore, who resides in the neighbourhood of coal, more especially if limestone or calcareous substances are at no great distance, farms at less expense, can afford to pay a higher rent, and may derive more profit from the land he cultivates, than if in these respects he were differently circumstanced.

SECT. VIII. *Extent of Land suitable for a Farm.*

4781. *The extent of ground which a farmer proposes to occupy demands due consideration.* If it be beyond his capital to cultivate or improve, he can derive no profit by taking it. On the other hand, a small occupation may not be worthy of his attention.

4782. *Farms as to size may be divided into three sorts:* small farms under 100 acres; moderate-sized farms, from 100 to 200 acres; large farms, from 200 to 1000 acres, and upwards, of land fit for cultivation. The expense of labour is now so great, and the rent of land so high, that the profits of a small farm are not sufficient, with the utmost frugality, or even parsimony, to maintain a family with comfort.

4783. *Moderate-sized farms* are well calculated for the dairy system, for the neighbourhood of large towns, and where capital is not abundant. There are few trades in which a small capital can be employed to a greater advantage than in a dairy farm, yet there is no branch of agriculture where such constant and unremitting attention is required. That is not to be expected from hired servants; but it is in the power of the wife and daughters of the farmer to perform, or at any rate to superintend, the whole business, and without their aid it cannot be rendered productive.

4784. *Moderate-sized farms* are general in the neighbourhood of towns. This necessarily results from the high rents paid in such situations; the shortness of the leases usually granted of land near towns; and the necessity the farmer is under of selling, in small quantities, the articles produced on his farm. On this subject it has been remarked, that farmers in the vicinity of large towns resemble retail shopkeepers, whose attention must be directed to small objects, by which a great deal of money is got, the greater part of which would be lost, without the most unremitting attention. The farmer at a distance from markets, who cultivates on a great scale, may be compared, on the other hand, to a wholesale trader, who, as his profits are less, requires a greater extent of land, for the purpose both of engaging his attention, and of enabling him to support that station of life in which he is placed. There is this difference also between farmers in the neighbourhood of towns, and those who reside at a distance from them, that the former find it more profitable to sell their produce, even such bulky articles as turnips, potatoes, clover, hay, and straw, than to fatten cattle for the butcher; and they are enabled to do so, without injury to their farms, as they can procure dung in return.

4785. *Farms of the largest size* differ in respect to the capital required. A mountain breeding farm of 5000 acres will not require more to stock it than an arable farm of 500 acres, and much less expense of labour to carry it on. In all cases the safe side for the farmer to lean to, is to prefer a farm rather under than exceeding his capital: and let him consider well beforehand whether he is going to commence a retail farmer for daily markets, or a manufacturer of produce on a large and ample scale; for the spirit, attention, and style of living of the one differs materially from that of the other.—The subject of this section and the two following having been treated in a general way as between landlord and tenant in the preceding chapter, will be here only briefly noticed as on the part of the tenant.

SECT. IX. *Tenure on which Lands are held for Farming.*

4786. *Perpetual tenures*, or absolute property in land, can never come into consideration with a farmer looking out for a farm. A proprietor cultivating his own property cannot, in correct language, be said to be a farmer; for to constitute the latter an essential requisite is the payment of rent.

4787. *The leases* on which lands are let for farming are for various terms, and with very different covenants. The shortest lease is from year to year, which, unless in the case of grass lands in the highest order, and of the richest quality, or under some other very peculiar circumstances, no prudent man, whose object was to make the most of his skill and capital, would accept of. Even leases for seven or ten years are too short for general purposes; a period of fourteen or fifteen years seems to be the shortest for arable lands, so as to admit of the tenant paying a full rent; but fourteen years, when the lands to be entered on are in bad condition, are too few, and twenty-one years much better for the true interests of both parties. In farming, however, as in every other occupation where there are more skill and capital in want of employment than can find subjects to work on, farms will be taken under circumstances, both in regard to leases and rent, that are highly unfavourable to the farmer; and if they do not end in his ruin will keep him always poor, and probably not only pay less interest for his capital than any other way in which he could have employed it, but also infringe on its amount. The rapid depreciation of currency which took place in Britain during the wars against the French deceived many farmers, and flattered them for a time with the gradual rise of markets year after year. However high land might be taken at the commencement of a lease, it was always considered a consolation that it would be a bargain by the time it was half done; and that the farmer's fortune would be made during the last few years of its endurance. When the currency of Britain was permitted to find its level with that of other countries, the delusion ceased, and the majority of farmers were partially or wholly ruined.

4788. *In regard to the covenants of a lease*, it is necessary that there should be such in every one as shall protect both landlord and tenant. Certain general covenants in regard to repairs, renewals if necessary, timber, minerals, entry and exit crops, are common to all leases. Regulations as to manure are required where hay and straw, and other crops, are sold not to be consumed on the farm. Water meadows, rich old grass lands, copse woods, hop grounds, orchards, &c. require special covenants. Fewest covenants are required for a mountain breeding farm; and in all cases there should be a clause entitling the tenant to an appeal, &c., and a hearing from the landlord, and perhaps a jury of landlords or agents and farmers, against covenants as to cropping, repair, or renewals, which may, from extraordinary circumstances, press particularly heavy on the tenant.

4789. *The power of the landlord to grant a lease*, with liberal conditions, may in some cases be required to be ascertained by the tenant; and in Scotland, where it is illegal to sublet a farm unless a clause to that effect has been inserted in the original lease, a farmer may cease to be the master of his own property, unless he has taken care to see that clause inserted. In England, for the most part, subletting a farm is no more prohibited than subletting a dwelling-house or a shop. When the laws of countries shall come to be founded on equity, this will be the case every where. At present they almost every where lean to the side of the powerful party, the landlord. In the progress of things it could not be otherwise.

SECT. X. *Rent.*

4790. *The rent of land*, in a general point of view, must always depend on a variety of circumstances; as the wealth of the country; its population; the price of produce; the amount of public and other burdens; the distance from markets; the means of conveyance; the competition among farmers; and other less important considerations: but the rent of any particular farm must be regulated by the nature of the soil; the duration

of the tenure, and the covenants contained in the lease ; the capital to be invested by the farmer in its culture ; and the expenses to which he is liable.

4791. *The rent of poor land* cannot possibly be the same as in the case of fertile lands. The labour of ploughing, harrowing, sowing, &c., when the land is in cultivation, is nearly the same, and yet the produce is greatly inferior, not only in quantity, but in quality. Indeed, where the produce is inconsiderable, or the quality much inferior, the whole, or nearly the whole, may be swallowed up by the expense of labour, and no rent whatever can be afforded, more especially in adverse seasons.

4792. *The duration of the tenure* must have a considerable effect in fixing the rent. No farmer can afford to pay the same sum for land on a short as if he held it on a long lease. The covenants, also, which are in fact a species of rent, must influence the money payments.

4793. *Rent must also depend on the capital invested in the cultivation of the farm.* Thus, if a farmer can lay out only 4*l.* of capital per acre, he may not be able to afford for it a higher rent than 10*s.* per acre ; if he lays out 7*l.* he may pay 14*s.* ; and with a capital of 10*l.* per acre, he may be enabled to pay 18*s.* or 20*s.* of rent.

4794. *The proportion of produce which should be paid as rent,* is a question that has long been considered as abstruse, mysterious, and very difficult to resolve. Some have supposed that one fifth was a reasonable proportion, while others contend for a fourth, or even a third part of the produce of arable land. But all former calculations on this subject are rendered fallacious by the effects of modern improvements. The rent ought certainly to depend upon the amount of the disposable produce ; and that produce in grain is greatly augmented, both by a diminution of the consumption on the farm, effected by improved implements, and a more correct arrangement of labour, and likewise a better cultivation of the land in tillage. Hence, while the price of wheat has greatly advanced during the last twenty years, above the average price of the preceding twenty, the rent of land has not only risen, but in a higher proportion. More grain, and that of a better quality, has been produced on the same extent of land, and a greater amount of disposable surplus has gone to market. Out of this surplus disposable produce, it is evident that the rent must be paid. But it is difficult to divide its amount between the landlord and tenant, as so much depends upon the seasons, and on the prices of the different articles which the farm produces. In bad seasons also, every deficiency of produce, in the acres set apart for supporting home population, must be made up from the disposable surplus ; nor is it possible to apply the same rules to all situations, soils, and climates, in all the various districts of an extensive country. It may be proper, however, to give some general idea of the proportion of produce paid as rent in Scotland and in England.

4795. *In Scotland,* the following table states what is considered to be a fair proportion, where the land is cultivated. One of the most scientific agricultural writers, and, at the same time, one who has had much experience in farming, informs us that "this table is a statement of Sir John Sinclair, who wishes to subject every thing to petty regulation ; and that there is no such proportion recognised in Scotland :"—

	<i>Per acre.</i>
Where land produces 10 <i>l.</i> 10 <i>s.</i> per acre per annum, one third, or	-£3 11 0
Where land produces 6 <i>l.</i> 12 <i>s.</i> per acre per annum, one fourth, or	- 1 13 0
Where land produces only 4 <i>l.</i> 5 <i>s.</i> per acre per annum, one fifth, or	- 0 17 0

4796. *In regard to grazing farms,* they are let on principles totally different from the arable ; namely, according to the quantity of stock they can maintain ; and as they are not liable to the same expense of management, both the landlord and the tenant receive larger shares of the produce than in the case of arable farms.

4797. *In England,* the tenant is allowed, on arable land, what is considered to be one moiety of the surplus, after defraying the expenses of cultivation, the taxes to which he is liable, and every other out-going. Hay land requires much less of his attention ; and for this he only obtains one third of the surplus. But the profits of grazing depending much on superior judgment in buying and selling stock, as well as skill in preventing or curing their diseases, the grazier is entitled to a share of the surplus, fully equal to that of his landlord. It has been contended, as a general principle, that as both the expense of cultivating land, and the value of its produce, are infinitely various, a farmer ought to calculate what profit he can make on his whole farm, without entering into details ; it being of little consequence to him whether he pays at the rate of 10*l.* or 10*s.* per acre, provided he makes an adequate interest on the capital invested. That is certainly a fair criterion on which a tenant may calculate what he ought to offer ; but a landlord, in estimating the rent he ought to insist on, will necessarily take into his consideration the produce that his land is capable of yielding, and what proportion of it, or of its value, at a fair average, he has reason to expect, under all the circumstances of the case.

4798. *Tithe.* In Scotland there is no tithe. In England, compositions for tithes are computed as six is to twenty-two ; so is the composition for tithe to the rent : so that land averaging 10*l.* 10*s.* per acre would, according to Sir John Sinclair's calculation, be charged for

Rent	£2 11 7½
Composition for tithe	19 4½
	£3 11 0

4799. *What the profits are to which a farmer is entitled,* is a question much disputed. The proper answer is simply this :— The common profits of capital invested in other commercial undertakings. As the subject, however, will bear talking about, let us hear what is said in the *Code* on this subject. On the one hand it is contended, that the produce of land is of such universal and absolute necessity to the existence of mankind, that it is not reasonable it should yield to him who raises it more than a fair profit. On the other hand it is urged, that a farmer is entitled to be fully recompensed for the application of a considerable capital, exposed to the uncertainty of the seasons, when it is managed with economy, and conducted with industry and skill ; and it has also been observed, that it is seldom more money is got by farming than an adequate interest for the capital invested. This is owing to competition, the articles produced being in numberless hands, who must bring them to market ; and necessity, the goods of the farmer being in general of a perishable nature, on the sale of which he depends for the payments he has to make, and the subsistence of his family. To prove how moderate the profits of farming in general are, it appears from the most careful enquiries, that on arable farms they rarely exceed from ten to fifteen per cent. on the capital invested, which is little enough, considering that few employments are more subject to casualties than farming, or require more uniform attention. Some arable farmers, possessed of superior skill and energy, and who have got leases on reasonable terms, may clear from fifteen to twenty per cent. ; while others, who are deficient in these qualities, or pay too high rents, frequently become insolvent. Certain it is, that the great majority of farmers merely contrive to live and bring up their families ; adding little or nothing to their capital, but that nominal addition which takes place in consequence of the depreciation of the currency.

4800. *In grazing farms* the case is different ; as they are attended with less expense of labour, and produce articles of a more luxurious description, for which a higher price will be given. Hence, in such farms, fifteen per cent. and upwards is not unusual. Besides, the grazier is more of a trader than the mere arable farmer ; is frequently buying as well as selling stock ; and sometimes makes money by judicious speculations, though occasionally, from a sudden fall of stock, his losses are considerable. The grazier who breeds superior stock, and thence incurs great expense, is certainly well entitled to more than common profit for his skill and attention.

4801. *For the mode in which rent should be paid, and the terms of payment, we refer to the succeeding Book.*

SECT. XI. *Taxes and other Burdens which affect the Farmer.*

4802. *Farmers are subjected to the payment of various taxes besides the rent paid to the landlord; some of them imposed for local purposes, and others for the general expenses of the state. The real amount of such burdens every careful tenant ought accurately to know before he bargains for his lease. They may be classed under the following heads: parochial, national, and miscellaneous.*

4803. *Parochial taxes* are for the support of the clergyman, for the maintenance of the poor, and, in Scotland, for providing a parochial schoolmaster. The mode of supporting the clergy in England, by paying them a tenth part of the produce of the land in kind, is highly injurious to agriculture, and a bar to improvement. It is a great bar to improvement, because an improving farmer, one more enlightened or more spirited than his neighbours, would pay more tithe by means of his outlay and his exertions, but it is not certain that he would likewise receive more profit. The produce would be more, but the expense would be greater. Nothing can be more obnoxious than a law by which, when a person expends a large sum, either in reclaiming wastes, or augmenting the fertility of land already cultivated, he should be under the necessity of yielding up one tenth of its produce to a person who has been liable to no share of the expense, who has run none of the risk, and who has sustained none of the labour attending the improvement. A commutation of tithe, therefore, instead of its being exacted in kind, would be one of the greatest benefits that could be conferred on agriculture; and there is not the least difficulty in effecting it, by giving to the tithe-owner either a proportion of the land, or by converting the tithe into a perpetual corn rent. Both these plans have been adopted in a variety of cases, by local acts in England, and they ought now to be enforced as a general system.

4804. *An assessment for the maintenance of the poor* is another parochial burden, which is annually increasing, and which, if not speedily regulated upon proper principles, will inevitably absorb a very large proportion of rent in England. Indeed, there are instances where, between the years 1815 and 1822, it has absorbed the whole. This tax is the most dangerous of all for the farmer, on account of its fluctuation; and, indeed, it may be said that it never falls, but continually rises. During infancy, in sickness, and in old age, assistance may be necessary; but, as Malthus justly observes, the poor-laws hold out support to the vicious and idle, at the expense of the prudent and the industrious. These payments also destroy the spirit of independence, and those ideas of honest pride which stimulate a man to use his utmost exertions in support of himself and his family; and, on its present footing, the boon is administered by the parish officers with caution and reluctance, and received by the poor with dissatisfaction and ingratitude.

4805. *The tithes and the poor-rates* are charges upon the land, and in fact come from the landlord's pocket rather than from the tenant's; but in their operation are often oppressive to the tenant, by rising in the course of the lease much higher than they were at the commencement; and as a farmer's rent is always considered by the overseer to be his income, he is charged on that; while the tradesman, who realises three times the amount, is only charged to the poor on the amount of rent of his house.

4806. *In Scotland, the poor are in general maintained by voluntary contributions*; but when these are not found to be sufficient, the proprietors of the parish, with the clergyman and vestry, or kirk-session, are directed to make a list of the indigent persons in the parish, and then to impose an assessment for their relief, one half to be paid by the proprietors, and the other half by the tenantry.

4807. *The national burdens in general*, as the duties on houses and windows, and other assessed taxes, or assessments for the support of militia-men's wives and families, for the conveyance of vagrants, or the prosecution of felons, fall no heavier upon the farmer than upon other classes of the community.

4808. *There are various miscellaneous burdens* affecting the farmer, as statute assessments for bridges, which are of such public utility, that moderate rates for their maintenance, properly applied, cannot be objected to: statute labour on the highways; constable dues, which are seldom of much moment; charges of the churchwardens, including the repairs of the church; and in some populous parishes, there is sometimes a burial-ground tax. All these are paid by the occupiers. In some places, also, there is a sewer tax, chargeable on the landlords, where it is not otherwise settled by express contract.

4809. *The vexations* to which farmers in England are subjected, from various uncertain burdens, operate as a premium to Scottish agriculture. It is ingeniously and justly remarked, that physical circumstances are much more favourable to agriculture in England than in her sister country; but these advantages are counteracted by the accumulation of moral evils, which might be removed if the legislature were to bestow on matters connected with the internal improvement of the country, and the means for promoting it, a portion of that attention which it so frequently gives to the amelioration or improvement of our foreign possessions. It ought to have been the business of the late Board of Agriculture to endeavour to prevail on the legislature to relieve agriculture from its moral and political evils; but, instead of this, they set about procuring and distributing statistical and professional information, comparatively of very inferior utility; and after receiving from government nearly 50,000*l.*, or, for any thing we know, more, left agriculture where they found it. Even in the particular line which the Board adopted, Marshall was a much more effectual instrument of agricultural improvement.

SECT. XII. *Other Particulars requiring a Farmer's Attention, with a View to the Renting of Land.*

4810. *A variety of miscellaneous particulars* require consideration before a prudent farmer will finally resolve to undertake the cultivation of a farm; as, the nature of the property on which the farm is situated; in particular, whether the estate is entailed, and to what extent the possessor of the estate is authorised to grant a lease; the character of the landlord, and, in case of his decease, that of his family, and of those whom they are likely to consult; the real condition of the farm in regard to the enclosures, drainage, buildings, &c.; the crops it has usually produced, and the manner in which it has been managed for some years preceding; the general state of the district, in regard to the price of labour, and the expense of living; the character of its inhabitants, in particular of the neighbouring farmers and labourers, and whether they are likely to promote or to discourage a spirit of improvement; the probability of subletting to advantage in case of not liking the situation, of finding a better bargain, or of death. The chances of settling one's family; as of marrying daughters, or of sons' making good marriages. The social state of the farmers, or those that would be considered one's neighbours; the number and

tone of clergy, and lawyers; the game, and the chances of disputes concerning it; the morals of the serving class; schools, places of worship, &c. It is evident, that in hardly any one instance can all the circumstances above enumerated be favourably combined. But the active and intelligent farmer will not be discouraged by the obstacles he may have to surmount; but will strenuously endeavour, by exertion, industry, and perseverance, to overcome the difficulties he must unavoidably encounter. These are vague generalities, and may be thought too commonplace for a work of this description; but the young farmer on the look-out for a farm may not be the worse for having his memory refreshed by them.

CHAP. II.

Considerations respecting Himself, which a Farmer ought to keep in view in selecting and hiring a Farm.

4811. *Whoever intends to embrace farming as a profession, will be less likely to meet with disappointment, if he previously examines a little into his own disposition and talents; and weighs his expectations against ordinary results. Nor is it less essential that he should estimate justly the extent to which his capital may be adequate, and keep regular accounts.*

SECT. I. *Personal Character and Expectations of a professional Farmer.*

4812. *Every one who proposes to farm with success, Professor Thaer observes, ought to unite energy and activity, to reflection, to experience, and to all necessary knowledge. It is true, he says, farming has long been considered as an occupation fit for a young man incapable for any other, and such have sometimes succeeded; but this has always been chiefly owing to a fortunate concurrence of circumstances, which it is not now very easy to meet with.*

4813. *The practice of agriculture consists of an infinite number of particular operations, each of which appears easy in itself, but is often for that very reason the more difficult to execute to the precise extent required; one operation so often interferes with another. To regulate them according to the given time and strength, and in such a way that none is neglected, or causes the neglect of others, requires at once a great deal of attention and activity, without iniquitude; of promptitude without precipitation; of general views, and yet with an extreme attention to details.*

4814. *To casualties and accidents no business is so much exposed as farming; and therefore, to enjoy an ordinary degree of happiness, Professor Thaer considers it essential that the farmer possess a certain tranquillity of mind. This, he says, may either be the result of a naturally phlegmatic habit of body, or of elevated views in religion or philosophy. These will enable him to bear with every misfortune arising from adverse seasons, or the death of live stock; and only permit him to regret accidents which result from his own neglect.*

4815. *The expectations of profit and happiness which a young farmer has formed ought to be well weighed against the profits and happiness of farmers in general. However superior a farmer may consider his own talents and abilities, he may rest assured there are a number as skilful and adroit as himself, and just as likely to realise extraordinary advantages. Let none therefore engage in farming, thinking to make more money than other farmers similarly circumstanced with himself. If from a happy concurrence of circumstances he is more than usually successful, so much the better, and let him consider it as partly owing to good fortune as well as good farming; but never let him set out on the supposition of gaining extraordinary advantages with only ordinary means.*

4816. *The profits of farming are much exaggerated by people in general; but it may be asserted as an unquestionable fact, that no capital affords less profit than that employed in farming, except that sunk in landed property. This is the natural result both of the universality of the business and of its nature. Farming is every where practised, and every one thinks he may easily become a farmer; hence high rents, which necessarily lessen the profits on capital. From the nature of farming, the capital employed is returned seldom. A tradesman may lay out and return his capital several times a year; but a farmer can never, generally speaking, grow more than one crop per annum. Suppose he succeeds in raising the best possible crops in his given circumstances, still his profits have an absolute limit: for if an ordinary crop be as five, and the best that can be grown be as seven, all that the most fortunate concurrence of circumstances will give is not great, and is easily foreseen. It is hardly possible for a farmer, paying the market price for his land, to make much more than a living for himself and family. Those few who have exceeded this, will be found to have had leases at low rents; indulgent landlords; to have profited by accidental rises in the market, or depreciation of currency; or to have become dealers in corn and cattle; and rarely indeed to have realised any thing considerable by mere good culture of a farm at the market price. Very different is the case of a tradesman, who, with the properties which we have mentioned as requisite for a good farmer, seldom fails of realising an independency.*

4817. *Many persons, chagrined with a city life, or tired of their profession, fancy they will find profit and happiness by retiring to the country and commencing farming. Independently of the pecuniary losses attending such a change, none is more certain of being attended with disappointment to the generality of men. The activity required, and the privations that must be endured, are too painful to be submitted to; whilst the dull uniformity of a farmer's life to one accustomed to the bustle of cities, becomes intolerable to such as do not find resources in their fire-sides, their own minds, or, as Professor Thaer observes, in the study of nature.*

4818. *The most likely persons to engage in farming with success are the sons of farmers, or such others as have been regularly brought up to the practice of every part of agriculture. They must also have an inclination for the profession, as well as a competent understanding of its theory or principles. Books are to be found every where, from which the science of the art is to be obtained; and there are eminent farmers in the improved districts who take apprentices as pupils.*

4819. *In The Husbandry of Scotland, the case is mentioned of Walker, of Mellendean, an eminent*

farmer of Roxburghshire, renting about 2866 acres of arable land, and distinguished for his skill in agriculture, who takes young men under him as apprentices, and these, instead of receiving wages, have uniformly paid him ten pounds each. Some of them remain with him two years, but the greater number only one. They eat in his kitchen, where they have always plenty of plain wholesome food. He takes none who are above living in that way, or who will not put their hands to every thing going forward on the farm. He has sometimes been offered ten times the above sum, to take in young gentlemen to eat and associate with his own family; but that he has uniformly declined. These young men have an opportunity of attending to every operation of husbandry, as practised on Walker's farm; and are taught to hold the plough, to sow, to build stacks, &c.

SECT. II. *Capital required by the Farmer.*

4820. *The importance of capital* in every branch of industry is universally acknowledged, and in none is it more requisite than in farming. When there is any deficiency in that important particular, the farmer cannot derive an adequate profit from his exertions, as he would necessarily be frequently obliged to dispose of his crops for less than their value, to procure ready money; and it would restrain him from making advantageous purchases, when even the most favourable opportunities occurred. An industrious, frugal, and intelligent farmer, who is punctual in his payments, and hence in good credit, will strive with many difficulties, and get on with less money than a man of a different character. But if he has not sufficient live stock to work his lands in the best manner, as well as to raise a sufficient quantity of manure; nor money to purchase the articles required for the farm; he must, under ordinary circumstances, live in a state of penury and hard labour; and the first unfavourable season, or other incidental misfortune, will probably sink him under the weight of his accumulated burdens. Farmers are too generally disposed to engage in larger farms than they have capital to stock and cultivate. This is a great error; for it makes many a person poor upon a large farm, who might live in comfort and acquire property upon one of less extent. No tenant can be secure without a surplus at command, not only for defraying the common expenses of labour, but those which may happen from any unexpected circumstance. When a farmer farms within his capital, he is enabled to embrace every favourable opportunity of buying when prices are low, and of selling when they are high.

4821. *The amount of capital* required must depend upon a variety of circumstances; as whether it is necessary for the farmer to expend any sum in the erection, or in the repair, of his farm-house and offices; what sum an in-coming tenant has to pay to his predecessor, for the straw of the crop, the dung left upon the farm, and other articles of similar nature; the condition of the farm at the commencement of the lease, and whether any sums must be laid out in drainage, enclosure, irrigation, levelling ridges, &c.; whether it is necessary to purchase lime, or other extraneous manures, and to what extent; on the period of entry, and the time at which the rent becomes payable, as this is sometimes exacted before there is any return from the lands, out of the actual produce of which it ought to be paid; and, lastly, on its being a grazing or an arable farm, or a mixture of both.

4822. *In pasture districts*, the common mode of estimating the amount of capital necessary is according to the amount of the rent; and it is calculated that, in ordinary pastures, every farmer ought to have at his command from three to five times the rent he has agreed to pay. But in the more fertile grazing districts, carrying stock worth from 20*l.* to 30*l.* and even upwards, per acre (as is the case in many parts of England), five rents are evidently insufficient. When prices are high, ten rents will frequently be required by those who breed superior stock, and enter with spirit into that new field of speculation and enterprise.

4823. *The capital required by an arable farmer* varies, according to circumstances, from 5*l.* to 10*l.* or even 15*l.* per acre. An ignorant, timid, and penurious farmer lays out the least sum he can possibly contrive; and consequently he obtains the smallest produce or profit from his farm. The profit, however, will always increase, when accompanied by spirit and industry, in proportion to the capital employed, if judiciously expended. At the same time, attention and economy cannot be dispensed with. It is ill-judged to purchase a horse at forty guineas, if one worth thirty can execute the labour of the farm; or to lay out sums unnecessarily upon expensive harness, loaded with useless ornaments. Prudent farmers also, who have not a large capital at command, when they commence business, often purchase some horses still fit for labour, though past their prime, and some breeding mares, or colts; and in five or six years, they are fully supplied with good stock, and can sometimes sell their old horses without much loss. In every case, such shifts must be resorted to, where there is any deficiency of capital.

4824. *A mixture of arable and grass farming* is, on the whole, the most profitable method of farming. Independently of the advantages to be derived from the alternate husbandry (which are always considerable), the chances of profit are much more numerous from a varied system than where one object is exclusively followed. Where this mixed mode of farming is practised, the farmer will frequently rely on the purchase of lean stock, instead of breeding his own; and derives great advantage from the quickness with which capital thus employed is returned. But, in that case, much must depend upon judicious selection. In general it may be said, that to stock a turnip-land arable farm, will require, at this time (1830), 5*l.* or 6*l.* and a clay-land farm from 7*l.* or 8*l.* per acre, according to circumstances.

4825. *This capital is necessarily divided into two parts.* The one is partly expended on implements, or stock of a more or less perishable nature, and partly vested in the soil; for this the farmer is entitled to a certain annual gain, adequate to replace, within a given number of years, the sum thus laid out. The other is employed in defraying the charges of labour, &c. as they occur throughout the year; the whole of which, with the interest, should be replaced by the yearly produce. These two branches of expense on a farm are the first to be attended to, both in order of time, and in magnitude of amount.

CHAP. III.

Choice of Stock for a Farm.

4826. *The stocking of a farm* may be considered as including live stock, implements, servants, and seed. A considerable portion of a farmer's capital is employed in manures, tillages, labour, &c. ; but a farm being once engaged, the above are the only descriptions of stock which admit of a choice.

SECT. I. *Choice of Live Stock.*

4827. *The animals required by a farmer* are of two kinds ; such as are employed to assist in labour ; and such as are used to convert the produce of the farm into food, or other disposable commodities.

SUBSECT. 1. *Live Stock for the Purposes of Labour.*

4828. *The animals of labour used in British farming* are exclusively the horse and the ox. Much difference of opinion formerly prevailed, as to which of these two animals should be preferred ; and the preference has generally been given by speculative writers to the ox, and by practical farmers to the horse. Lord Kaimes in the last century, and Lord Somerville in the present, may be considered the principal advocates for the ox. To their arguments, and to all others, the following objections have been stated by the able author of the supplement to the 6th edition of *The Gentleman Farmer* ; and they may be considered as conveying the sentiments, and according with the practice, of all the best informed and most extensive British farmers.

4829. *The first objection to oxen* is, that they are unfit for the various labours of modern husbandry, — for travelling on hard roads in particular, — for all distant carriages, — and generally for every kind of work which requires despatch : and what sort of work often does not in this variable climate ? A great part of a farmer's work is indeed carried on at home ; and it may still be thought that this may be done by oxen, while one or more horse teams are employed in carrying the produce to market, and bringing home manure and fuel. But it is unnecessary to appeal to the author of *The Wealth of Nations*, to prove the impracticability of this division of labour, unless upon very large farms ; and even on these the advantages of such an arrangement are at best extremely problematical. The different kinds of farm-work do not proceed at the same time ; but every season, and even every change of weather, demands the farmer's attention to some particular employment, rather than to others. When his teams are capable of performing every sort of work, he brings them all to bear for a time upon the most important labours of every season ; and when that is despatched, or interrupted by unfavourable weather, the less urgent branches are speedily executed by the same means. This is one cause, more important perhaps than any other, why oxen have ceased to be employed ; for even ploughing, which they can perform better than any other kind of work, is scarcely ever going forward all the year ; and for some months in winter, the weather often prevents it altogether.

4830. *Another objection* is, that an ox team capable of performing the work of two horses, even such kind of work as they can perform, consumes the produce of considerably more land than the horses. If this be the case, it is of no great importance, either to the farmer or the community, whether the land be under oats, or under herbage and roots. The only circumstance to be attended to here is, the carcase of the ox : the value of this, in stating the consumption of produce, must be added to the value of his labour. He consumes, from his birth till he goes to the shambles, the produce of a certain number of acres of land ; the return he makes for this is so much beef, and so many years' labour. The consumption of produce must therefore be divided between these two articles. To find the share that should be allotted to each, the first thing is to ascertain how many acres of grass and roots would produce the same weight of beef from an ox, bred and reared for beef alone, and slaughtered at three or four years old. What remains has been consumed in producing labour. The next thing is to compare this consumption with that of the horse, which produces nothing but labour. By this simple test, the question, viewing it upon a broad national ground, must evidently be determined. Every one may easily make such a calculation suited to the circumstances of his farm ; none that could be offered would apply to every situation. But it will be found, that if even three oxen were able to do the work of two horses, the advantages in this point of view would still be on the side of the horses ; and the first objection applies with undiminished force besides.

4831. *The money-price of the horse and ox*, it is evident, is merely a temporary and incidental circumstance, which depends upon the demand. A work ox may be got for less than half the price of a horse, because there is little or no demand for working oxen ; while the demand for horses by manufactures, commerce, pleasure, and war, enhances the price of farm-horses, as well as of the food they consume. Those who wish to see horses banished from all sorts of agricultural labour, would do well to consider where they are to be reared for the numerous wants of the other classes of society. Besides, if two oxen must be kept for doing the work of one horse, it ought to be foreseen, that though beef may be more abundant than at present, there will be a corresponding deficiency in the production of mutton and wool. A greater portion of the arable land of the country must be withdrawn from yielding the food of man directly, and kept under cattle crops, which, however necessary to a certain extent for preserving the fertility of the soil, do not return human food, on a comparison with corn crops, in so great a proportion as that of one to six from any given extent of land of the same quality.

4832. *The demand for oxen is confined almost every where to the shambles* ; and by the improvements of modern husbandry, they are brought to a state of profitable maturity at an early age. No difference in price at setting to work, — no increase of weight while working, — no saving on the value of the food consumed, can ever make it the interest of tillage farmers generally to keep oxen as formerly, till they are eight or ten years old. They judiciously obtain the two products from different kinds of animals, each of them from the kind which is best fitted by nature to afford it, — the labour from the horse, and the beef alone from the ox. And though the price of the horse is almost wholly sunk at last, during the period of his labour he has been paying a part of it every year to a fund, which, before his usual term expires, becomes sufficiently large to indemnify his owner. The ox, on the other hand, is changed three or four times during the same

period ; and each of them gives nearly as large a carcass for the food of man as if his days had been unprofitably prolonged in executing labour, from which he has been gradually exempted in Britain, in France, and in other countries, very nearly in proportion to the progress of correct systems of husbandry.

4833. *The description of horse* which a farmer ought to choose will depend chiefly on the soil of the farm, and partly also on the quantity of road-work. Stiff lands require obviously a heavier and more powerful breed than such as are light and hilly. In the latter case, two of the best breeds are the Clevelands and Clydesdale, or some local cross with these breeds. In general, it is not advisable to procure horses from a climate materially different from that where they are to remain ; and therefore, for various reasons, a prudent farmer will look out for the best in his neighbourhood. Often, however, he is obliged to take the stock of his predecessor ; and this he can only get rid of or improve to his mind by degrees. The farm-horses in most parts of England are much too cumbersome and heavy, and are more fitted for drawing heavy drays or waggons in towns than for the quick step required in the operations of agriculture.

4834. *The objections of Davis of Longleat to the using of large heavy-heeled horses*, in preference to the smart, the active, and the really useful breeds, merit particular attention. In some situations, the steepness of the hills and the heaviness of the soil require more than ordinary strength ; but, in such cases, he maintains that it would be better to add to the number of horses than to increase their size. Great horses not only cost proportionably more at first than small ones, but require much more food, and of a better quality, to keep up their flesh. The Wiltshire carter also takes a pride in keeping them as fat as possible ; and their food (which is generally barley) is given without stint. In many instances, indeed, the expense of keeping a fine team of horses amounts nearly to the rent of the farm on which they are worked. They are purchased young when two years' old colts, and sold at five or six years of age for the London drays and waggons. The expense of their maintenance is very seldom counterbalanced by the difference of price, more especially as such horses are gently worked when young, that they may attain their full size and beauty. In ploughing light soils, the strength of a dray-horse is not wanted ; and in heavy soils, the weight of the animal does injury to the land.

SUBJECT. 2. *Choice of Live Stock for the Purposes of breeding or feeding.*

4835. *The most desirable properties of live stock destined for food* are considered in *The Code of Agriculture*, in respect to size, form, a tendency to grow, early maturity, hardiness of constitution, prolific properties, quality of flesh, a disposition to fatten, and lightness of offal.

4836. *The bulk of an animal* was the sole criterion of its value before the improvements introduced by Bakewell ; and if a great size could be obtained, more regard was paid to the price the animal ultimately fetched than to the cost of its food. Of late, since breeders began to calculate with more precision, small or moderate-sized animals have been generally preferred, for the following reasons :—

4837. *Small-sized animals* are more easily kept, they thrive on shorter herbage, they collect food where a large animal could hardly exist, and thence are more profitable. Their meat is finer grained, produces richer gravy, has often a superior flavour, and is commonly more nicely marbled, or veined with fat, especially when they have been fed for two years. Large animals are not so well calculated for general consumption as the moderate-sized, particularly in hot weather ; large animals poach pastures more than small ones ; they are not so active, require more rest, collect their food with more labour, and will only consume the nicer and more delicate sorts of plants. Small cows of the true dairy breeds give proportionably more milk than large ones. Small cattle may be fattened solely on grass of even moderate quality ; whereas the large require the richest pastures, or to be stall-fed, the expense of which exhausts the profit of the farmer. It is much easier to procure well-shaped and kindly-feeding stock of a small size than of a large one. Small-sized cattle may be kept by many persons who cannot afford either to purchase or to maintain large ones, and their loss, if any accident should happen to them, can be more easily borne. The small-sized sell better ; for a butcher, from a conviction that, in proportion to their respective dimensions, there is a greater superficies of valuable parts in a small than a large animal, will give more money for two oxen of twelve stone each per quarter than for one of twenty-four stone.

4838. *In favour of the large-sized* it is, on the other hand, contended, that without debating whether from their birth till they are slaughtered the large or the small one eats most for its size, yet on the whole the large one will pay the grazier or the farmer who fattens him as well for his food ; that though some large oxen are coarse-grained, yet where attention is paid to the breed (as is the case with the Herefordshire), the large ox is as delicate food as the small one ; that if the small-sized are better calculated for the consumption of private families, of villages, or of small towns, yet that large cattle are fitter for the markets of great towns, and in particular of the metropolis ; that were the flesh of the small-sized ox better when fresh, yet the meat of the large-sized is unquestionably more calculated for salting, a most essential object in a maritime and commercial country, — for the thicker the beef, the better it will retain its juices when salted, and the fitter it is for long voyages ; that the hide of the large ox is of very great consequence in various manufactures ; that large stock are in general distinguished by a greater quietness of disposition ; that where the pastures are good, cattle and sheep will increase in size, without any particular attention on the part of the breeder ; large animals are therefore naturally the proper stock for such pastures ; that the art of fattening cattle, and even sheep, with oil-cake, being much improved and extended, the advantage of that practice would be of less consequence, unless large oxen were bred, as small oxen can be fattened with grass and turnips as well as oil-cake ; and, lastly, that large oxen are better calculated for working than small ones, two large oxen being equal to four small ones in the plough or the cart.

4839. *Such are the arguments generally made use of on both sides of the question* ; from which it appears that much must depend upon pastures, taste, mode of consumption, markets, &c. and that both sides have their advantages. The intelligent breeder, however, (unless his pastures are of a nature peculiarly forcing,) will naturally prefer a moderate size in the stock he rears. Davis of Longleat, one of the ablest agriculturists England has produced, has given some useful observations on the subject of size. He laments that the attempts which have been made to improve the breeds of cows, horses, and sheep, have proceeded too much upon the principle of enlarging the size of the animal ; whereas, in general, the only real improvement has been made in the pig, and that was by reducing its size, and introducing a kind that will live harder, and come to greater perfection at an earlier age.

4840. *Though it is extremely desirable to bring the shape of cattle* to as much perfection as possible, yet profit and utility ought not to be sacrificed for mere beauty which may please the eye, but will not fill the pocket ; and which, depending much upon caprice, must be often changing. In regard to form, the most experienced breeders seem to concur in the following particulars :— That the form or shape should be compact, so that no part of the animal should be disproportioned to the other parts, and the whole should

be distinguished by a general fulness and rotundity of shape; that the chest should be broad, for no animal whose chest is narrow can easily be made fat; that the carcase should be deep and straight; that the belly should be of a moderate size; for when it is more capacious than common in young animals, it shows a diseased state, and in older ones it is considered a proof that the animal will not return in flesh, in milk, or in labour, the value of the extra quantity of food which it consumes; that the legs should be short, for the long-limbed individuals of the same family or race are found to be the least hardy, and the most difficult to rear or to fatten; and that the head, the bones, and other parts of inferior value, should be as small as is consistent with strength, and with the other properties which the animal ought to possess. In animals bred for the shambles, the form must likewise be such as to contain the greatest possible proportion of the finer, compared with the coarser and less valuable parts of the animal. This, by selection, may be attained, and thus the wishes of the consumer may be gratified. As to the broad loins, and full hips, which are considered as a point of excellence in particular breeds, it is evident that the old narrow and thin make required improvement; but the alteration is now carried to a faulty excess, and often occasions great difficulty and danger in calving.

4841. *The form of animals* has fortunately attracted the attention of an eminent surgeon, Henry Cline, Esq. of London, whose doctrines we have already laid down at length, and the substance of which is:— That the external form is only an indication of the internal structure; that the lungs of an animal form the first object to be attended to, for on their size and soundness the health and strength of an animal principally depend; that the external indications of the size of the lungs are the form and size of the chest, and its breadth in particular; that the head should be small, as by this the birth is facilitated; as it affords other advantages in feeding, &c., and as it generally indicates that the animal is of a good breed; that the length of the neck should be in proportion to the size of the animal, that it may collect its food with ease; and that the muscles and tendons should be large, by which an animal is enabled to travel with greater facility. It was formerly the practice to estimate the value of animals by the size of their bones. A large bone was considered to be a great merit; and a fine-boned animal always implied great size. It is now known that this doctrine was carried too far. The strength of the animal does not depend upon the bones, but on the muscles; and when the bones are disproportionably large, it indicates, in Cline's opinion, an imperfection in the organs of nutrition. Bakewell strongly insisted on the advantage of small bones; and the celebrated John Hunter declared, that small bones were generally attended with corpulence in all the subjects he had an opportunity of examining. A small bone, however, being heavier and more substantial, requires as much nourishment as a hollow one with a larger circumference.

4842. *Among the qualities* for which thorough-bred cattle and sheep are distinguished, that of being good growers, and having a good length of frame, is not the least essential. The meaning of which is, that the animal should not only be of a strong and healthy constitution, but speedily should grow to a proper size. As specimens of rapid growth, a steer of three years old, when well fed, will weigh from 80 to 90 or 100 stone, 14lb. to the stone; and a two-year old Leicester wether, from 25 to 28lb. per quarter, immediately after his second fleece is taken from him. Animals having the property of growing, are usually straight in their back and belly; their shoulders well thrown back, and their belly rather light than otherwise. At the same time, a gauntness and paucity of intestines should be guarded against, as a most material defect, indicating a very unthriving animal. Being too light of bone, as it is termed, is also a great fault. A good grower, or hardy animal, has always a middling-sized bone. A bull distinguished for getting good growers is inestimable; but one whose progeny takes an unnatural or gigantic size ought to be avoided.

4843. *Arriving soon at perfection*, not only in point of growth or size, but in respect of fatness, is a material object for the farmer, as his profit must in a great measure depend upon it. Where animals, bred for the carcase merely, become fat at an early age, they not only return sooner the price of their food, with profit to the feeder, but in general, also, a greater value for their consumption, than slow-feeding animals. This desirable property greatly depends on a mild and docile disposition; and as this docility of temper is much owing to the manner in which the animal is brought up, attention to inure them early to be familiar cannot be too much recommended. A tamed breed also has other advantages. It is not so apt to injure fences, or to break into adjacent fields; consequently it is less liable to accidents, and can be reared, supported, and fattened at less expense. The property of early maturity, in a populous country, where the consumption of meat is great, is extremely beneficial to the public, as it evidently tends to furnish greater supplies to the market; and this propensity to fatten at an early age is a sure proof that an animal will fatten speedily at a later period of his life.

4844. *The possession of a hardy and healthy constitution*, is, in the wilder and bleaker parts of a country, a most valuable property in stock. Where the surface is barren, and the climate rigorous, it is essential that the stock bred and maintained there should be able to endure the severities and vicissitudes of the weather, as well as scarcity of food, hard work, or any other circumstance in its treatment that might subject a more delicate breed to injury. In this respect, different kinds of stock greatly vary; and it is a matter of much consequence to select, for different situations, cattle with constitutions suitable to the place where they are to be kept. It is a popular belief, that dark colours are indications of hardiness. In mountain breeds of cattle, a rough pile is reckoned a desirable property, more especially when they are to be kept out all winter: it enables them to face the storm, instead of shrinking from it. Hardy breeds are exempted from various diseases, such as having yellow fat, and being blackfleshed, defects so injurious to stock.

4845. *The prolific quality of a breed* is a matter deserving attention. The females of some breeds both bear more frequently than usual, and also have frequently more than one at a birth. This property runs more strikingly in sub-varieties, or individual families; and though partly owing to something in the habits of animals, and partly to their previous good or bad treatment, yet in some degree seems to depend upon the seasons, some years being more distinguished for twins than others. In breeding, not only the number, but the sex of the offspring, in some cases, seems to depend upon the female parent. Two cows produced fourteen females each in fifteen years, though the bull was changed every year: it is singular, that when they produced a bull calf, it was in the same year. Under similar circumstances, a great number of males have been produced by the same cow in succession, but not to the same extent.

4846. *By the quality of their flesh*, breeds are likewise distinguished. In some kinds it is coarse, hard, and fibrous; in others of a finer grain or texture. In some breeds, also, the flavour of the meat is superior; the gravy they produce, instead of being white and insipid, is high coloured, well flavoured, and rich; and the fat is intermixed among the fibres of the muscles, giving the meat a streaked, or marbled appearance. Breeds whose flesh have these properties are peculiarly valuable. Hence two animals of nearly the same degree of fatness and weight, and who could be fed at nearly the same expense to the husbandman, will sell at very different prices, merely from the known character of their meat.

4847. *A disposition to fatten* is a great object in animals destined for the shambles. Some animals possess this property during the whole progress of their lives, while in others it only takes place at a more advanced period, when they have attained their full growth, and are furnished at the same time with a suitable supply of food. There are in this respect other distinctions: most sorts of cattle and sheep, which have been bred in hilly countries, will become fat on lowland pastures, on which the more refined breeds would barely live; some animals take on fat very quickly, when the proper food has been supplied, and some individuals have been found, even in the same breed, which have, in a given time, consumed the least proportional weight of the same kind of food, yet have become fat at the quickest rate. Even in the human race, with little food, some will grow immoderately corpulent. It is probably from internal conformation that this property of rapid fattening is derived.

4848. *The advantages and disadvantages of fattening cattle and sheep*, at least to the extent frequently practised at present, are points that have of late attracted much public attention. But any controversy

on that subject can only arise from want of proper discrimination. Fat meat is unquestionably more nourishing than lean, though to digest this oily matter there are required, on account of its difficult solubility, a good bile, much saliva, and a strong stomach; consequently none, except those who are in the most vigorous state of health, or who are employed in hard labour, can properly digest it. Though fat meat, however, is unfit for general consumption, yet experiments in the art of fattening animals are likely to promote useful discoveries; and though, in the course of trying a number of experiments, errors and excesses may be committed, yet on the whole advantage may be derived from the knowledge thus to be obtained. As the bone also gains but little in the fattening animal, and the other offal becomes proportionably less, as the animal becomes more fat, the public has not sustained much loss by over-fatted animals. To kill even hogs till they are thoroughly fat, is exceeding bad economy. An ox or cow, though the little flesh it has may be of good quality, yet presents, when lean, little but skin and bone; and if slaughtered in that state, would neither indemnify the owner for the expense of breeding and maintaining it, nor benefit the public. A coarse and heavy-fleshed ox, which would require a very long time and much good food to fatten, may be slaughtered with most advantage while rather lean. It is not, however, so much the extent of fat, as the want of a sufficient quantity of lean flesh, of which the consumer complains; for it cannot be doubted, that the lean flesh of a fat animal is better in quality, and contains more nourishment, than the flesh of a lean animal.

4849. *Handling well.* The graziers and butchers in various parts of the kingdom have recourse to feeling the skin, or cellular membrane, for ascertaining a disposition to fatten; and since Bakewell directed the public attention so much to breeding, that practice has become more generally known. Handling cannot easily be defined, and can only be learned by experience. The skin and flesh of cattle, when handled, should feel soft to the touch, somewhat resembling that of a mole, but with a little more resistance to the finger. A soft and mellow skin must be more pliable, and more easily stretched out, to receive any extraordinary quantity of fat and muscle, than a thick or tough one. The rigid-skinned animal must, therefore, always be the most difficult to fatten. In a good sheep, the skin is not only soft and mellow, but in some degree elastic. Neither cattle nor sheep can be reckoned good, whatever their shapes may be, unless they are first-rate handlers. The improved short-horned breed, besides their mellowness of skin, are likewise distinguished by softness and silkiness of hair.

4850. *Lightness of offal.* An animal solely bred for the shambles should have as little offal, or parts of inferior value, as possible (consistently with the health of the animal), and consequently a greater proportion of meat applicable as food for man. This, therefore, the skilful farmer will also keep in view in selecting his species of stock. (*Code, &c.*)

4851. *The Rev. Henry Berry*, who has paid much attention to the subject of breeding and feeding cattle, and written several valuable papers on the subject in the *British Farmer's Magazine*, seems to prefer for general purposes the *improved short-horns*. "These cattle," he says, "at three years old, are equal to Hereford cattle at four years old; and they are bred from cows which prove much more profitable for the dairy than the Herefords." At the same time, he admits that the Hereford cattle are excellent to purchase with a view to fattening, because in a lean state at four years old they will of course not bear an increased price in proportion to the increased time required to render one of them equal to a short-horn of three years. For breeders, therefore, he decidedly recommends the short-horns; and he has given an interesting history of this breed of cattle for the last eighty years, the period which has elapsed since it attracted attention. It was imported from Holland to the banks of the Tees; or, at least, it is the result of a cross between the breed so imported and the native breed of that district. (*Improved Short-Horns, &c.* By the Rev. Henry Berry. 2d edit. 1830.)

SECT. II. *Choice of Agricultural Implements, Seeds, and Plants.*

4852. *The variety and excellence of agricultural implements* is so great, that the prudent farmer, in regard to these, as well as in every other branch of his art, must study economy. He should not incur an unnecessary expense in buying them, or in purchasing more than are essentially requisite, and can be profitably used. This maxim ought to be more especially attended to by young improvers, who are often tempted, under the specious idea of diminishing labour and saving expense, to buy a superfluous quantity of implements, which they afterwards find are of little use. (*Coventry's Disc.* p. 47.) It is remarked by an intelligent author on matters of husbandry, that a great diversity of implements, as they are more rarely used, prove in general a source of vexation and disappointment, rather than of satisfaction, to the farmer.

4853. *The different implements required by the farmer* are: those of tillage; for drilling or sowing corn; for reaping corn; for harvesting corn; for threshing and cleaning corn; for mowing and harvesting hay; of conveyance; for draining; for harnessing stock; for rolling land; for the dairy; and, for miscellaneous purposes.

4854. *In purchasing implements*, the following rules are to be observed: they should be simple in their construction, both that their uses may be more easily understood, and that any common workman may be able to repair them when they get out of order; the materials should be of a durable nature, that the labour may be less liable to interruption from their accidental failure; their form should be firm and compact, that they may not be injured by jolts and shaking; and that they may be more safely worked by country labourers, who are but little accustomed to the use of delicate tools. In the larger machines, symmetry and lightness of shape ought to be particularly attended to: for a heavy carriage, like a great horse, is worn out by its own weight, nearly as much as by what he carries. The wood should be cut up and placed in a position the best calculated to resist pressure; and mortises, so likely to weaken the wood, should, as much as possible, be avoided; at the same time, implements should be made as light as is consistent with the strength that is necessary. Their price should be such, that farmers in moderate circumstances can afford to buy them; yet for the sake of a low price, the judicious farmer will not purchase articles either of a flimsy fabric or a faulty form; and implements ought to be suited to the nature of the country, whether hilly or level, and more especially to the quality of the soil; for those which are calculated for light land will not answer equally well in soils that are heavy and adhesive. (*Code.*)

4855. *In the choice of seed corn*, regard must be had to procure it from a suitable soil and climate, and of a suitable variety. A change from one soil to another of a different

quality, is generally found advantageous ; but this is not always the case as to climate. Thus, some of the varieties of oats, as the Angus oat, which answers well in most parts of Scotland, is found not to fill in the ear, but to shrivel up after blossoming, in the south of England. In like manner, the woolly-chaffed white wheats of Essex and Kent rot in the ear when grown in the moist climate of Lancashire. In settling on a farm in a country with which the farmer is little acquainted, he will often find it advisable to select the best seed he can find in the neighbourhood, and probably to resift it and free it from the seeds of weeds and imperfect grains. Particular care is requisite in selecting the seed of the bean and pea, as no crop depends more on the variety being suited to the soil and climate. Thus, on hot gravelly soils in the south, the late grey pea would produce little haulm and no pulse ; but the early varieties, or the pearl pea, will produce a fair proportion of both.

4856. *The only small seeds* the farmer has to sow on a large scale, are the clovers, grasses, the different varieties of turnip, and probably the mangold wurzel and carrot. No expense or trouble should be spared to procure the best turnip seed ; as if that is either mixed by impregnation with other varieties of the *Brássica* tribe, or has been raised from a degenerate small-rooted parentage, the progeny will never come to any size. The same may be said of carrot or mangold seed, raised from small misshapen roots. Even rape seed should be raised from the strongest and largest rooted plants, as these always produce a stronger progeny.

4857. *The selection and propagation of improved agricultural seeds* has till lately been very little attended to. But the subject has been taken up by Mr. Sinclair of New Cross, Mr. Shirreff of Mungos Wells, Mr. Gorrie of Rait, and others ; and we have little doubt some greatly improved varieties of our more useful field plants will be the result. Mr. Shirreff mentions (*Quar. Jour. Ag.* vol. i. p. 366.), that the variety of the Swedish turnip cultivated in East Lothian had, by judicious selection of the roots from which seed was saved, been improved in nutritious value upwards of 300 per cent. "Potatoes and Swedish turnip," Mr. Shirreff says, "appear to be susceptible of farther improvement by judicious selection, as well as the different grains so long cultivated in this country, and which, in almost every instance, have become spurious. But whatever may be the degree of improvement of which the agricultural produce of the country is susceptible, by the propagation of genuine seeds of the best varieties of plants, one remarkable feature of such an improvement is, that it could be carried into effect without any additional investment of capital, or destruction of that already employed. It would require, in the first instance, only a slight degree of observation amongst practical farmers to select the best varieties, and afterwards a small exercise of patience in their propagation. The whole increase of produce obtained by such means would go to support the unagricultural part of the population ; it would, in the first instance, be clear gain to the occupiers, and ultimately to the owners of land. The difference of produce, arising from sowing the seed of a good and a bad variety of a plant, is so great, that it does not seem inconsistent with probability to state, that the gross agricultural produce of the country might be augmented, in the course of a few years, through the agency of improved seeds, to the amount of seven per cent. ; and as the farmer's home consumption of produce, by such means, would be increased nearly ten per cent., what an enormous fund this forms for maintaining the unagricultural part of the population, and augmenting the income of landholders !

4858. *The facility of propagating genuine seeds*, will become manifest from a statement of my practice. In the spring of 1823, a vigorous wheat-plant, near the centre of a field, was marked out, which produced 63 ears, that yielded 2473 grains. These were dibbled in the autumn of the same year ; the produce of the second and third seasons sown broadcast in the ordinary way ; and the fourth harvest put me in possession of nearly forty quarters of sound grain. In the spring of this year, I planted a fine purple-top Swedish turnip, that yielded (exclusively of the seeds picked by birds, and those lost in threshing and cleaning the produce,) 100,296 grains, a number capable of furnishing plants for upwards of five imperial acres. One-tenth of an acre was sown with the produce, in the end of July, for a seed crop, part of which it is in contemplation to sow for the same purpose in July 1829. In short, if the produce of the turnip in question had been carefully cultivated to the utmost extent, the third year's produce of seed would have more than supplied the demand of Great Britain for a season.

4859. *Plants and animals are both organic bodies*, from the germs of whose fecundating organs proceed new races, which yield crops ; and thus an extensive view of improving agriculture through the agency of genuine seeds embraces the propagation of live stock. Now, however important the propagation of live stock may be, when considered by itself, yet, when viewed in connection with our agricultural system, embracing the cultivation and improvement of the herbage which support animals, as well as those plants, parts of which form the ingredients of human sustenance, it becomes less imposing. The analogy subsisting between animal and vegetable life is known and acknowledged ; and it may be stated, that the union of the male and female organs of different varieties of a plant, under favourable circumstances, produces a new race, which partakes of the qualities of both parents, and which is termed a hybrid. Now, hybrid varieties of agricultural plants, when suffered to intermingle with the original kind, disseminate their influence around them like cross-bred animals, unrestrained in their intercourse with the general herd, till the character of the stock becomes changed, and consequently deteriorated or improved. In either case, propagation from the best variety alone would be attended with good effects. The principles of propagating vegetable and animal life are nearly the same ; but the propagation of vegetables must exceed that of animals in importance, as much as the vegetable produce of the country surpasses that of animals. Indeed animals may justly be considered mere machines for converting our inferior herbage into nutriment of a different description ; grasses and roots are the raw materials, butcher's meat the manufactured commodity."

4860. *The importance of attending to varieties of cultivated plants* has been ably pointed out by Mr. Bishop, at once a scientific botanist and an experienced practical gardener. "By means of varieties," he says, "the produce of our gardens and fields are not only increased in a tenfold degree, but the quality of the produce is improved in a still greater proportion. In them we perceive the labour and assiduity of man triumphing over the sterility of unassisted nature, and succeeding in giving birth to a race of beings calculated to supply his wants in a manner that original species never could have done. The difference between varieties that have sprung from the same species fits them for different purposes, and for different soils, situations, and climates. Some, by reason of their robust natures, are winter vegetables ; and others, by being early, are spring vegetables ; while some are in perfection in summer, and others in autumn. The fruit produced by some is fit to eat when pulled off the tree ; while the fruit of others is valuable by reason of its keeping till that season, when Nature rests to recruit her strength. Thus, in edible plants and fruits, we are supplied with an agreeable change throughout the year, from a difference in varieties that have sprung from the same species. In the earlier ages of the world, no idea could have been entertained of the

excellence some varieties have attained over their originals. Who, upon viewing the wild cabbage that grows along our sea-coast, would ever imagine that cauliflower or broccoli would have been produced by the same? Or who would expect the well-formed apple of a pound's weight from the verjuice plant in our hedges? Many instances might be noticed of original species that are scarcely fit to be eaten by the beasts of the field, the varieties of which afford a nutritious and wholesome food for man. Upon comparing the original variety of the *Daucus Carota*, the *Pastinaca sativa*, and some others indigenous to our climate, with their varieties produced by culture, we are struck with their great inferiority, and cannot help reflecting on the hapless condition of that hungry savage who first taught us their use; for nothing short of the greatest privation could ever have led to that discovery. Indeed, nothing is more obvious, upon comparing original species with their varieties produced by culture, than that we, by means of the latter, enjoy a vegetable food far preferable to that of our forefathers; a circumstance from which it may be inferred that posterity is destined to enjoy a better than that which we do now. For although it is reasonable to believe that there exists a degree of excellence attainable by varieties over the species whence they have sprung, yet as that degree is unknown, and as it is probably beyond the power of man, of cultivation, or of time, to determine the same, we are justified in regarding it as progressive, and in considering the production of a good variety as the sign or harbinger of a better.

4861. *The power of distinguishing varieties*, and of forming some idea of their worth at sight, is an attainment much to be desired, because valuable varieties may sometimes appear to those who have it not in their power to prove them by trial; and if they have, the probability is, that the means to be employed require more care, time, and attention than they are disposed to bestow on plants the merits of which are doubtful: whereas, were such persons capable of forming an estimate of the worth of varieties from their appearance, then would they use means for their preservation, whenever their appearance was found to indicate superiority. That this is an attainment of considerable importance, will be readily allowed; yet, that it, in some cases, requires the most strict attention, appears from the circumstance of varieties being oftentimes valuable, though not conspicuously so. Let us suppose, for instance, that in a field of wheat there exists a plant, a new variety, having two more fertile joints in its spike, and equal to the surrounding wheat in every other respect: a man accustomed to make the most minute observations, would scarcely observe such a variety, unless otherwise distinguished by some peculiar badge; nor would any but a person versed in plants know that it was of superior value if placed before him. How many varieties answering this description may have existed and escaped observation, which, had they been observed, and carefully treated, would have proved an invaluable acquisition to the community! The number of fertile joints in the spike of the wheat generally cultivated, varies from eighteen to twenty-two; and the inhabitants of Great Britain and Ireland amount to nearly the same number of millions: therefore, as the wheat produced in those islands has been of late years sufficient, or nearly sufficient, to supply the inhabitants thereof with bread, it is evident that a variety with two additional fertile joints, and equal in other respects to the varieties at present in cultivation, would, when it became an object of general culture, afford a supply of bread to at least two millions of souls, without even another acre being brought into cultivation, or one additional drop of sweat from the brow of the husbandman.

4862. *The same varieties are not repeatedly produced by culture*; if they were, there would not exist that necessity for strict observation and skill on the part of observers; because, if a variety were lost or destroyed, we might look forward to its re-appearance: or did we possess the power of producing varieties, and of producing them late or early, tall or dwarf, sweet or sour, or just as we might wish to have them, then might we plead an excuse for inattention. But experience shows, that when a variety is lost, it is for ever lost; and the slightest reflection cannot fail of convincing us, that our power of producing them is most limited. Indeed, our knowledge only enables us to produce those of the intermediate kind; while varieties that confer extension or excellence are as likely to be produced from the seed sown and treated by the humble labourer as from that sown and treated by the ablest horticulturist, the most skilful botanist, or most profound philosopher of the age. From these remarks it is obvious, that the benefits mankind derive from the varieties produced by culture are numerous and important, and that the discovery of those of merit is an object highly deserving of our attention." (*Bishop's Causal Botany.*)

4863. *The varieties of wheat and barley in general cultivation*, Mr. Gorrie observes, are "not numerous; but were a part of that attention paid to the production of new and improved varieties of field-beans, peas, oats, barley, and wheat, which is now almost wasted on live stock, the same success might follow, and varieties of each of these useful species of grain might be found as far surpassing those now in cultivation as the modern breeds of horses and cattle surpass those of former days. To effect this, a simple process only is necessary. When any two varieties are intended to be used in 'crossing,' it is necessary that they should be sown at such periods as may render them likely to flower at the same time; and we would recommend that such plants should be sown or transplanted into flower-pots, particularly the variety to be used as the *female breeder*. The parts of fructification of all the *Cerealia* tribe are composed of a stigma, or fringed substance, which crowns the embryo grain; three anthers or male parts, which have either a purple or yellow colour; and firm, small, round, or rather longish cylindrical knobs, with a hollow line longitudinally along the middle, on the side farthest from the filament which supports these anthers. Allowing that there are six plants, say of wheat, in a pot to be impregnated, let the variety possessing the greatest proportion of desirable qualities be selected for the *male*, from a field or otherwise, and, before the anthers appear outside the glume, let the chaff be opened by a slight touch of the forefinger; cut off the anthers of all the ears growing on the plants in the pot, and then take the male parts of the variety wished to be improved, which have been newly out of the chaff, and, before the farina is all dissipated, touch the stigma of all the embryo grains whence the anthers have been previously removed, gently, with newly burst anthers, till the stigma is partially covered with the dust or pollen; keep the plants at a distance from the fields where grain of the same sort is coming in the flower, till the flowering season is fairly over, then, to prevent sparrows or other birds from picking the impregnated grains, plunge the pots to the brims in a field of the same kind of grain. Save every seed, and sow them carefully next season; if the process has been properly performed, there may be many varieties even from one ear; the best should be marked, and the produce of each stalk worthy of notice kept, and propagated distinctly by itself. If all the farmers in a district were to submit five or six plants only to such process, we might soon have hundreds of new varieties, and it is certainly within the limits of probability to expect a few varieties superior to any now in cultivation." (*Perth Miscellany*, vol. i. p. 17.)

4864. *Grain, seeds, and roots intended for reproduction* are not required to have come to the same degree of maturity on the plant, as when intended for meal or other products to be consumed as food. The cause of this has never been satisfactorily explained; all that is alleged being the conjecture, that the cotyledons of the seed are better fitted for entering the vessels of the minute plant, when they are not of such a farinaceous nature, as when these cotyledons are more mature. "That grain not perfectly matured is fully qualified for seed, is evident from places situated near rivers or lakes, where the grain in some seasons is subject to be what the people who cultivate such situations term *blasted* or *mildewed*. This happens in autumn, before the grain is matured, and is probably caused by fogs or damps which arise from the water. This *blast* discolours the straw, and renders it so friable that it will hardly bind itself; the grain never receives any more nourishment, is shrivelled and light, and soon assumes a ripe appearance, and so small a quantity of farinaceous matter will be contained in the grains, that a sheaf, after being reaped, will feel as light in the hand as if it had been previously threshed; and yet, for as bad as it appears, it is commonly taken for seed, and never fails to give a luxuriant crop, provided it escape the following autumn." (*Ibid.*)

4865. *Of the plants* which the farmer has to choose for stock, the chief is the potato; and every one knows that no circumstances in the soil, climate, or culture will compensate for planting a bad sort. The potato requires a climate rather humid than otherwise, and rather moderate and equable in temperature than hot: hence the best crops are found in Lancashire, Dumfriesshire, and Ayrshire in Britain, and in Ireland, where the climate is every where moist. Excellently flavoured potatoes are also grown on mossy lands in most parts of the country. The prudent farmer will be particularly careful in choosing this description of plant stock, and also in changing it frequently, so as to ensure prolificacy and flavour. The general result of experience is decidedly in favour of unripe tubers for the purpose of propagation. A number of important papers on this subject will be found in the first and second volumes of the *Gardener's Magazine*, all confirmatory of the advantages of selecting tubers which are immature.

SECT. III. *Choice of Servants.*

4866. *On the moral and professional character of his servants* much of the comfort of the farmer depends; and every one who has farmed near large towns, and at a distance from them, knows how great the difference is in every description of labourers. The servants required in farmeries are, the bailiff or head ploughman, common ploughmen, shepherds, labourers of all-work, herdsmen, and women. Sometimes apprentices and pupils are taken; but their labour is not often to be much depended on.

4867. *A bailiff* is required only in the largest description of farms, occupied by a professional farmer; and is not often required to act as market-man. In general young men are preferred, who look forward to higher situations, as gentlemen's bailiffs or land stewards. Most farmers require only a head ploughman, who works the best pair of horses, and takes the lead of, and sets the example to, the other ploughmen in every description of work.

4868. *Ploughmen* should, if possible, be yearly servants, and reside upon the farm; if married, cottages should be provided for them. Weekly or occasional ploughmen are found comparatively unsteady; they are continually wandering from one master to another, and are very precarious supports of a tillage farm: for they may quit their service at the most inconvenient time, unless bribed by higher wages; and the farmer may thus lose the benefit of the finest part of the season. Where ploughmen and day labourers, however, are married, they are more to be depended upon than unmarried domestic servants, more especially when the labourer has a family, which ties him down to regular industry.

4869. *The mode of hiring servants* at what are called public statutes, so general in many parts of England, is justly reprobated as having a tendency to vitiate their minds, enabling them to get places without reference to character, exposing good servants to be corrupted by the bad, promoting dissipation, and causing a cessation of country business for some days, and an awkwardness in it for some time afterwards. When hiring servants, it would be extremely important, if possible, to get rid of any injurious perquisites, which are often prejudicial to the interests of the master, without being of any advantage to the servant. For instance, in Yorkshire and in other districts it is a custom to give farm servants liquor both morning and evening, whatever is the nature and urgency of the work. Nothing can be more absurd than permitting a ploughman to stop for half an hour in a winter day to drink ale, while his horses are neglected and shivering with cold.

4870. *The following plan of maintaining the hinds or ploughmen in the best cultivated districts in Scotland*, is found by experience to be greatly superior to any other mode hitherto adopted.

4871. *Proper houses* are built for the farm servants contiguous to every farmstead. This gives them an opportunity of settling in life, and greatly tends to promote their future welfare. Thus also the farmer has his people at all times within reach for carrying on his business.

4872. *The farm servants*, when married, receive the greater part of their wages in the produce of the soil, which gives them an interest in the prosperity of the concern in which they are employed, and in a manner obliges them to eat and drink comfortably; while young men often starve themselves in order to save money for drinking or clothes, in either of which cases they are deficient in the requisite animal strength. At least under this mode of payment they are certain of being supplied with the necessaries of life, and a rise of prices does not affect them; whereas, when their wages are paid in money, they are exposed to many temptations of spending it which their circumstances can ill afford, and during a rise of prices they are sometimes reduced to considerable difficulties. From the adoption of an opposite system, habits of sobriety and economy, so conspicuous among the farm servants of Scotland, and the advantages of which cannot be too highly appreciated, have arisen and still prevail in these districts.

4873. A most important branch of this system is, that *almost every married man has a cow* of a moderate size kept for him by the farmer all the year round. This is a boon of great utility to his family. The prospect of enjoying this advantage has an excellent effect upon the morals of young unmarried servants, who in general make it a point to lay up as much of their yearly wages as will enable them to purchase a cow and furniture for a house when they enter into the married state. These savings, under different circumstances, would most probably have been spent in dissipation.

4874. *They have also several other perquisites*, as a piece of ground for potatoes and flax (about one-eighth part of an acre for each); liberty to keep a pig, half a dozen hens, and bees; their fuel is carried home to them; they receive a small allowance in money per journey when sent from home with corn, or for coals or lime; and during the harvest they are maintained by the farmer, that they may be always at hand.

4875. *There are nowhere to be met with more active, respectable, and conscientious servants than those who are kept according to this system.* There is hardly an instance of their soliciting relief from the public. They rear numerous families, who are trained to industry and knowledge in the operations of agriculture, and whose assistance in weeding the crops, &c. is of considerable service to the farmer. They become attached to the farm, take an interest in its prosperity, and seldom think of removing from it. Under this system every great farm is a species of little colony, of which the farmer is the resident governor. Nor, on the whole, can there be a more gratifying spectacle than to see a large estate under the direction of an intelligent landlord, or of an agent competent to the task of managing it to advantage; where the farms are of a proper size; where they are occupied by industrious and skilful tenants, anxious to promote, in consequence of the leases they enjoy, the improvement of the land in their possession; and where the cultivation is carried on by a number of married servants enjoying a fair competence and rearing large families, sufficient not only to replace themselves, but also, from their surplus population, to supply the demand and even the waste of the other industrious classes of the community. Such a system, there is reason to believe, is brought to a higher degree of perfection and carried to a greater extent in the more improved districts of Scotland than perhaps in any other country in Europe. (*Code, &c.*)

4876. *A shepherd* is of course only requisite on sheep farms; and no description of farm servant is required to be so steady and attentive. At the lambing season much of the farmer's property is in his hands, and depends on his unwearied exertions early and late. Such servants should be well paid and comfortably treated.

4877. *The labourers* required on a farm are few; in general, one for field operations, as hedge and ditch work, roads, the garden, cleaning out furrows, &c.; and another for attending to the cattle, pigs, and straw-yard, killing sheep and pigs when required, &c. will be sufficient. Both will assist in harvest, hay-time, threshing, filling dung, &c. These men are much better servants when married and hired by the year, than when accidental day labourers.

4878. *The female servants* required in a farmery are casual, as haymakers, turnip hoers, &c.; or yearly, as house, dairy, and poultry maids. Much depends on the steadiness of the first class; and it is in general better to select them from the families of the married servants, by which means their conduct and conversation is observable by their parents and relations. A skilful dairy-maid is a most valuable servant, and it is well when the cattle-keeper is her husband; both may live in the farmer's house (provided they have no children), and the man may act as groom to the master's horse and chaise, and assist in brewing, butchery, &c. In the cheese districts, men often milk the cows, and manage the whole process of the dairy; but females are surely much better calculated for a business of so domestic a nature, and where so much depends on cleanliness.

4879. *Farmer's apprentices* are not common, but parish boys are so disposed of in some parts of the west of England, and might be so generally. They are said to make the best and steadiest servants; and indeed the remaining in one situation, and under one good master for a fixed period, say not less than three years, must have a great tendency to fix the character and morals of youth in every line or condition of life.

4880. *Apprentices intended for farmers* are generally young men who have received a tolerable education beforehand, and have attained to manhood or nearly so. These pay a premium, and are regularly instructed in the operations of farming. We have already alluded to the example of Walker, who considers such apprentices, notwithstanding the care required to instruct them, rather useful than otherwise. (*Husb. of Scot. vol. ii. p. 106.*)

4881. *To train ploughmen to habits of activity and diligence* is of great importance. In some districts they are proverbial for the slowness of their step, which they teach their horses; whereas these animals, if accustomed to it, would move with as much ease to themselves in a quick as in a slow pace. Hence their ploughs seldom go above two miles in an hour, and sometimes even less; whereas, where the soil is light and sandy, they might go at the rate of three miles and a half. Farmers are greater sufferers than they imagine by this habitual indolence of their workmen, which extends from the plough to all their other employments, for it makes a very important difference in the expense of labour. (*Code.*)

CHAP. IV.

General Management of a Farm.

4882. The importance of an *orderly systematic mode of managing* every concern is sufficiently obvious. The points which chiefly demand a farmer's attention are the accounts of money transactions, the management of servants, and the regulation of labours.

SECT. I. *Keeping Accounts.*

4883. It is a maxim of the Dutch, that "*no one is ever ruined who keeps good accounts,*" which are said in *The Code of Agriculture* to be not so common among farmers as they ought to be; persons employed in other professions being generally much more attentive and correct. Among gentlemen farmers there is often a systematic regularity in all their proceedings, and their pages of debtor and creditor, of expense and profit, are as strictly kept as those of any banking-house in the metropolis. But with the generality of farmers the case is widely different. It rarely happens that books are kept by

4889.

Cash Account.

Dr.				Cash paid.				Cr.			
<i>Cash received.</i>				<i>Cash paid.</i>							
When received.	Of whom received.	On what account received.	Amount.			When paid.	To whom paid.	On what account paid.	Amount.		
			<i>L.</i>	<i>s.</i>	<i>d.</i>				<i>L.</i>	<i>s.</i>	<i>d.</i>
				<i>Articles from the Farm consumed (Amount of).</i>							
				When.		By whom.		What Articles.	<i>L. s. d.</i>		
Total received.								Total paid -			

4890.

Management of Arable Land.

No. of Years.	What Year.	What Crop.	Acres.	When begun.	PREPARING.																
					<i>Ploughing, Harrowing, Rolling.</i>				<i>Manure.</i>				<i>Sowing Seed.</i>								
					No. of Men.	Days.	At per Day.	Amount.	Sort.	Quantity.	Price.	Amount.	Sort.	Quantity.	Price.	Amount.					
																	<i>L.</i>	<i>s.</i>	<i>d.</i>	<i>L.</i>	<i>s.</i>

4891.

Management of Pasture Land.

No. of Years.	What Year.	<i>How many Head of Cattle fed.</i>					<i>Produce of Hay, &c.</i>							Posted to Folio.						
		Oxen.	Horses.	Sheep.	Cows.	At per Head.	Amount.	When begun.	No. of Hands.	Amount paid.	No. of Loads.	At per Load.	Amount.							
															<i>L.</i>	<i>s.</i>	<i>d.</i>	<i>L.</i>	<i>s.</i>	<i>d.</i>

4895.

Stock Account.

Increase and Decrease of Live Stock.					What Part of the Farm occupied by the Cattle.								
Description.				Increase by		Decrease by		Total.	Date when sent in.	When taken out.	Number and Description of Cattle.	No. of the Field.	Nature of the Crop in the Field.
		No.	Purchase.	Birth.	Death.	Sale.							
Sheep.	Rams												
	Ewes	Spaniards											
	Wethers												
	R. Lambs	Spaniards											
	E. Lambs	Ditto											
Cattle.	Bulls	-	-	-	-								
	Cows	-	-	-	-								
	Oxen	-	-	-	-								
	Heifers	-	-	-	-								
	B. Calves	-	-	-	-								
	C. Calves	-	-	-	-								
Pigs.	Boars	-	-	-	-								
	Sows	-	-	-	-								
	Barrows	-	-	-	-								
	Pigs	-	-	-	-								
Horses.	Horses	-	-	-	-								
	Mares	-	-	-	-								
	Colts	-	-	-	-								
Poultry and Eggs.	Turkeys	-	-	-	-								
	Poults	-	-	-	-								
	Fowls	-	-	-	-								
	Chickens	-	-	-	-								
	Geese	-	-	-	-								
	Goslings	-	-	-	-								
	Ducks	-	-	-	-								
	Ducklings	-	-	-	-								
	Pigeons	-	-	-	-								
Eggs	-	-	-	-									

4896. *These forms* may be useful, by directing the attention of farmers to the particulars of which they should keep an accurate record ; but as to any particular system of accounts applicable to farmers a good deal of delusion seems to prevail, as if the established modes in general use among mercantile men would not answer. In fact, there is no correct mode of keeping accounts but by the principles of double entry.

4897. *The account books for a common farmer* may be, a cash-book for all receipts and payments, specifying each ; a ledger for accounts with dealers and tradesmen ; and a stock book for taking, once a year, an inventory and valuation of stock, crop, manures, tillages, and every thing that a tenant could dispose of or be paid for on quitting his farm. Farming may be carried on with the greatest accuracy and safety, as to money matters, by means of the above books, and a few pocket memorandum books for labourers' time, jobs, &c. With the exception of a time-book, such as we have before described (3383), we should never require more, even from a proprietor's bailiff ; many of whom the nine forms just given (4887) would only puzzle, and some we have known them lead to the greatest errors and confusion. *Munro's Guide to Farm Book-keeping* (Edin. 12mo. 1821) may be recommended to the practical farmer ; but no form of books, or mode of procedure will enable a farmer to know whether he is losing or gaining but that of taking stock.

4898. *A form for a cattle stock account* has been recommended by Sir Patrick Murray, of which it may be useful to present a specimen. This form, Sir Patrick observes, has been kept at his estate of Ochtertyre, in Perthshire, for twenty-two years, and found perfectly adapted to the purpose in view ; being sufficiently simple in form to be understood by every farm manager, and sufficiently comprehensive in particulars to embrace all the requisite details. They may be either made up quarterly, half-yearly, or yearly. Sir Patrick adopts the half-yearly mode.

SECT. II. *Management of Servants.*

4900. *In former times*, farm servants lived at the same table with their masters, and that is still the practice in those districts where the farms are small. On moderate-sized, and on large farms, they are usually sent to a separate table; but of late a custom has been introduced of putting them on board-wages. This is a most pernicious practice; which often leads them to the ale-house, corrupts their morals, and injures their health. It is a better plan, with a view of lessening trouble, to board them with the bailiff; but it is still more desirable for the farmer to have them under his own eye, that he may attend to their moral conduct. He will find much more useful assistance from the decent and the orderly than from the idle and the profligate.

4901. *The best mode of managing yearly married servants*, whether ploughmen or labourers, we conceive to be that already referred to (4870) as practised in Northumberland, and other northern counties. Marshal (*Review of Bailey's Northumberland*) calls it a remain of feudal times; but certainly, if it be so, it appears one of those remains which should be carefully preserved. We may challenge the empire to produce servants and farm operations equal to those where this system is adopted. The great excellence of the system consists on its being founded in the comfort of the servant.

4902. *The permanent labourers* on a farm ought to be treated in the same manner as the ploughmen; and indeed it is much to be wished, for the sake both of humanity and morality, that all married labourers, who live in the country, should have gardens attached to their cottages, if not a cow kept, and a pig and fowls, in the manner of the Scottish ploughmen. Some valuable observations on this subject will be found in *The Husbandry of Scotland*.

4903. *Temporary labourers*, or such as are engaged for hay-making, reaping, turnip-hoeing, &c. are for the most part beyond the control of the farmer, as to their living and lodging. It is a good practice, however, where hay-making and reaping are performed by the day, to feed the operators, and to lodge on the premises such of them as have not homes in the neighbourhood; providing them with a dry loft and warm blankets. Piece or job-work, however, is now becoming so very general, in all farm operations performed by occasional labourers, that attention to these particulars becomes unnecessary, and the farmer's chief business is to see that the work be properly done.

4904. *A day's work* of a country labourer, is ten hours during the spring, summer, and autumn quarters. Farmers, however, are not at all uniform in their hours of working during these periods. Some begin at five o'clock, rest three hours at mid-day, during the more violent heat of the sun, and fill up their day's work by beginning again at one o'clock, and ending at six in the evening. Others begin at six, and end at six, allowing half an hour at breakfast, and an hour at dinner. But although these are the ordinary hours, both for servants and labourers, during the more busy seasons of the year, yet neither of them will scruple to work either sooner or later, when occasion requires. In regard to the winter months, the hours of labour are from the dawn of morning, as long as it is light, with the allowance of about half an hour at mid-day for dinner.

4905. *That the rate of labour* must in a great measure depend upon the price of grain, is a general principle. In England, the value of a peck of wheat, and in Scotland, of a peck of oatmeal (being the principal articles of subsistence of the lower orders of the people in the two countries), were long accounted an equivalent to the daily pay of a labourer. In both countries, however, the price of potatoes has, of late years, had a considerable influence on the rate of labour; and in England, the effects of the poor laws have tended to keep down that rate below the increased price of provisions, and thus have deranged the natural progress of things. It has been ascertained, that a man, his wife, and from two to three children, if wheat is their habitual food, will require ten gallons weekly. When they live on bread, hard-working people ought to have the best kind, as that will furnish the most nutrition. How, then, could a labourer and his family exist upon wages of from 6s. to 9s. per week, when wheat is from 8s. to 10s. or 12s. per bushel? The difference is compensated by the poor-rates, a most exceptionable mode of making up the deficiency; for labour would otherwise have found its own level, and the labourer would have obtained the price of a bushel and a half of wheat weekly.

4906. *In Scotland*, the rate of labour has increased beyond the price of provisions. Prior to 1792, the average price of a peck of oatmeal was 1s. 1d., and the average price of a day's labour in summer 1s. 1½d., which nearly corresponded with the principle above stated: but the average price of a peck of oatmeal in 1810 was 1s. 3¾d., whilst the average price of a day's labour was 1s. 10½d.; which shows, in a most satisfactory manner, the very great improvement that has taken place in the lot of the labouring classes in that part of the United Kingdom. (*Gen. Rep.* vol. iii. p. 262.)

4907. *The practice of giving labourers grain, &c. at a cheap rate* was adopted by George III., who carried on farming operations to a considerable extent, allowing his labourers flour at a fixed price, whatever wheat might sell for. This benevolent system has been practised by several gentlemen farmers, some of whom have allowed bread, and others a daily quantity of milk, at moderate prices. The same system is general in several of the western counties, as in Dorset, Devon, and Cornwall, where the labourers have a standing supply of bread-corn; of wheat at 6s. and of barley at 3s. per bushel. In some of the midland

counties the day-wages are regulated by the price of the best wheaten bread : thus the price of a half-peck loaf forms the day-wages for out-of-door farm servants. Of late years this rule has been departed from in favour of the labourers : thus, when bread is at 1s. 8d. the half-peck, then wages are 1s. 10d. ; and when at 2s., the wages are 2s. 4d.

4908. *Most descriptions of country labour*, performed without the aid of horses, may be let by the job. Farey, in his excellent *Report of Derbyshire*, informs us, that besides all ordinary labour, the late John Billingsley, of Ashwick Grove, in Somersetshire, let his ploughing, harrowing, rolling, sowing, turning of corn when cut, hay-making, &c. by the acre ; from which he found great advantages, even where his own oxen and horses were used by the takers of the work. Whether we regard despatch, economy, perfection of rural works, or the bettering of the condition of the labourers therein, nothing will contribute so much to all these as a general system of letting works at fair and truly apportioned prices, according to the degree of labour and skill required in each kind of work. Few persons have doubted that despatch and economy are attainable by this method ; but those who have indolently or improperly gone about the letting of their labour, have uniformly complained of its being slovenly done, and of the proneness of the men to cheat when so employed. Such frauds are to be expected in all modes of employment, and can only be counteracted, or made to disappear, by competent knowledge and due vigilance in the employer, or his agents and foremen, who ought to study and understand the time and degree of exertion and skill, as well as the best methods, in all their minutiae, of performing the various works they have to let. At first sight these might seem to be very difficult and unattainable qualifications in farmers' bailiffs or foremen, but it is nevertheless certain, that a proper system and perseverance will soon overcome these difficulties. One of the first requisites is, the keeping of accurate and methodical day-accounts of all men employed ; and, on the measuring up and calculating of every job of work, to register how much has been earned per day, and never to attempt abatement of the amount, should this even greatly exceed the ordinary day's pay of the country ; but let this experience gained operate in fixing the price of the next job of the same work, in order to lessen the earnings by degrees, of fully competent and industrious men, to $1\frac{3}{4}$ or $1\frac{1}{4}$ times the ordinary wages when working by the day.

4909. *Form the men into small gangs*, according to their abilities and industry, and always set the best gang about any new kind of work, or one whose prices want regulating : encourage these by liberal prices at first, gradually lowering them ; and by degrees introduce the other gangs to work with or near them at the same kind of work. On the discovery of any material slight of or deceptions in the work, at the time of measuring it, more than their proportionate values should be deducted for them, and a separate job made to one of the best gangs of men, for completing or altering it : by which means shame is made to operate, with loss of earnings, in favour of greater skill, attention, and honesty in future. When the necessity occurs of employing even the best men by the day, let the periods be as short as possible, and the prices considerably below job earnings ; and contrive, by the offer of a desirable job to follow, to make it their interest and wish to despatch the work that is necessary to be done by the day, in order to get again to piece-work. The men being thus induced to study and contrive the readiest and best methods of performing every part of their labour, and of expending their time, the work will unquestionably be better done than by the thoughtless drones who usually work by the day. And that these are the true methods of bettering the condition of the labourers, Malthus has ably shown in theory ; and all those who have adopted and persevered in them have seen the same in practice. (*Farey's Derbyshire*, vol. iii. 192.)

SECT. III. *Arrangement of Farm Labour.*

4910. *The importance of order and system* we have already insisted on (3370), and the subject can hardly be too often repeated. To conduct an extensive farm well is not a matter of trivial moment, or one to the management of which every man is competent. Much may be effected by capital, skill, and industry ; but even these will not always ensure success without judicious arrangement. With it, a farm furnishes an uninterrupted succession of useful labour during all the seasons of the year ; and the most is made that circumstances will admit of, by regularly employing the labouring persons and cattle, at such works as are likely to be the most profitable. Under such a system it is hardly to be credited how little time is lost, either of the men or horses, in the course of a whole year. This is a great object ; for each horse may be estimated at three shillings per day, and each man at two shillings. Every day, therefore, in which a man and horse are unemployed occasions the loss of at least five shillings to the husbandman.

4911. *As the foundation of a proper arrangement*, it is necessary to have a plan of the farm, or at least a list of the fields or parcels of land into which it is divided, describing their productive extent, the quality of the soil, the preceding crops, the cultivation given to each, and the species and quantity of manure they have severally received. The future treatment of each field, for a succession of years, may then be resolved on with more probability of success. With the assistance of such a statement, every autumn an arrangement of crops for the ensuing year ought to be made out ; classing the fields or pieces of land, according to the purposes for which they are respectively intended. The number of acres allotted for arable land, meadow, or pasture, will thus be ascertained. It will not then be difficult to discover what number of horses and labourers will be

required during the season for the fields in culture, nor the live stock that will be necessary for the pasture land. The works of summer and harvest will likewise be foreseen, and proper hands engaged in due time to perform them.

4912. *A farmer should have constantly in view a judicious rotation of crops*, according to the nature and quality of his soil, and should arrange the quantity and succession of labour accordingly. Team labour, when frost and bad weather do not intervene, should be arranged for some months; and hand labour, for some weeks, according to the season of the year. "A general memorandum list of business to be done," may therefore be useful, that nothing may escape the memory, and that the most requisite work may be brought forward first, if suitable to the state of the weather. In this way the labour will go on regularly, and without confusion; while, by a proper attention, either a distribution of labour, or an occasional consolidation of it, may be applied to every part of the farm.

4913. *As general rules*, connected with the arrangement, and the successful management of a farm, the following are particularly to be recommended: —

4914. *The farmer ought to rise early*, and see that others do so. In the winter season breakfast should be taken by candle-light, for by this means an hour is gained which many farmers indolently lose; though six hours in a week are nearly equal to the working part of a winter day. This is a material object, where a number of servants are employed. It is also particularly necessary for farmers to insist on the punctual performance of their orders.

4915. *The whole farm should be regularly inspected*, and not only every field examined, but every beast seen, at least once a day, either by the occupier, or by some intelligent servant.

4916. In a considerable farm, it is of the utmost consequence to have *servants specially appropriated for each of the most important departments of labour*; for there is often a great loss of time, where persons are frequently changing their employments. Besides, where the division of labour is introduced, work is executed not only more expeditiously, but also much better, in consequence of the same hands being constantly employed in one particular department. For that purpose, the ploughmen ought never to be employed in manual labour, but regularly kept at work with their horses, when the weather will admit of it.

4917. *To arrange the operation of ploughing*, according to the soils cultivated, is an object of essential importance. On many farms there are fields which are soon rendered unfit to be ploughed, either by much rain or by severe drought. In such cases, the prudent farmer, before the wet season commences, should plough such land as in the greatest danger of being injured by too much wet; and before the dry period of the year sets in, he should till such land as in the greatest danger of being rendered unfit for ploughing by too much drought. The season between seed-time and winter may be well occupied in working soils intended to be sown with beans, oats, barley, and other spring crops. On farms where these rules are attended to there is always some land in a proper condition to be ploughed, or to be worked by the improved harrows or grubbers; and there is never any necessity either for delaying the work, or performing it improperly.

4918. *Every means should be thought of to diminish labour, or to increase its power*. For instance, by proper arrangement, five horses may do as much labour as six perform, according to the usual mode of employing them. One horse may be employed in carting turnips during winter, or in other necessary farm-work at other seasons, without the necessity of reducing the number of ploughs. When driving dung from the farm-yard, three carts may be used, one always filling in the yard, another going to the field, and a third returning; the leading horse of the empty cart ought then to be unyoked, and put to the full one. In the same manner, while one pair of horses are preparing the land for sowing turnips, the other three horses may be employed in carrying the dung to the land, either with two or three carts, as the situation of the ground may happen to require. By extending the same management to other farm operations, a considerable saving of labour may be effected.

4919. *Previously to engaging in a work*, whether of ordinary practice, or of intended improvement, the best consideration of which the farmer is capable ought to be given to it, till he is satisfied that it is advisable for him to attempt it. When begun, he ought to proceed in it with much attention and perseverance, until he has given it a fair trial. It is a main object, in carrying on improvements, not to attempt too much at once; and never to begin a work without a probability of being able to finish it in due season.

4920. *By the adoption of these rules, every farmer will be master of his time*, so that every thing required to be done will be performed at the proper moment, and not delayed till the season and opportunity have been lost. The impediments arising from bad weather, sick servants, or the occasional and necessary absence of the master, will, in that case, be of little consequence, nor will they embarrass the operations to be carried on; and the occupier will not be prevented from attending to even the smallest concerns connected with his business, on the aggregate of which his prosperity depends.

SECT. IV. *Domestic Management and personal Expenses.*

4921. *On domestic affairs* a hint may suffice. Young farmers beginning house-keeping, like most others in similar circumstances, are apt to sink too great a proportion of their capital in furniture, and furnishing riding-horses, carriages, &c.; and sometimes to live up to, or even beyond, their income. We do not mean that farmers should not live as well as other men of the same property; but merely that all beginners should live within their income. Even in the marketing expenses care is requisite; and the prudent farmer will do well, every penny or sixpence he lays out, to reckon up in his mind what that sum per day would amount to in a year. The amount will often astonish him, and lead to economy and, where practicable, retrenchment. Saving, as Franklin has inculcated, is the only certain way of accumulating money.

4922. *In regard to housekeeping*, it is observed in *The Code of Agriculture*, that the safest plan is, not to suffer it to exceed a certain sum for bought articles weekly. An annual sum should be allotted for clothing, and the personal expenses of the farmer, his

wife and children, which ought not to be exceeded. The whole allotted expense should be considerably within the probable receipts; and, if possible, one eighth of the income annually received should be laid up for contingencies, or expended in extra improvements on the farm.

BOOK VI.

CULTURE OF FARM LANDS.

4923. *THE business of farming* consists of the culture of vegetables, and the treatment or culture of animals; in practice these are generally carried on together, but may be more conveniently treated of apart. In this Book, therefore, we confine ourselves to the culture of vegetable, and shall consider in succession the general processes of culture; the culture of corn and pulse; of roots and leaves; of herbage plants; of grasses; and of manufactorial plants.

CHAP. I.

General Processes common to Farm Lands.

4924. *Among general processes*, those which merit particular notice in this place are, the rotation of crops, the working of fallows, and the management of manures. The theory of these processes has been already given in treating of soils and manures (PART II. BOOK III.); and it therefore only remains to detail their application to practice under different circumstances.

SECT. I. *Rotation of Crops suitable to different Descriptions of Soils.*

4925. *The proper distribution of crops, and a plan for their succession*, is one of the first subjects to which a farmer newly entered on a farm requires to direct his attention. The kind of crops to be raised are determined in a great measure by the climate, soil, and demand, and the quantity of each by the value, demand, and the adjustment of farm labour.

4926. *In the adjustment of farm labour*, the great art is to divide it as equally as possible throughout the year. Thus it would not answer in any situation to sow exclusively autumn crops, as wheat or rye; nor only spring corns, as oats or barley; for by so doing all the labour of seed-time would come on at once, and the same of harvest work, while the rest of the year there would be little to do on the farm. But by sowing a portion of each of these and other crops, the labour both of seed-time and harvest is divided and rendered easier, and is more likely to be done well and in season. But this point is so obvious as not to require elucidation.

4927. *The succession or rotation of crops* is a point on which the profits of the farmer depend more than on any other. It is remarked by Arthur Young, that agricultural writers, previously to the middle of the eighteenth century, paid little or no attention to it. They recite, he says, courses good, bad, and execrable in the same tone, as matters not open to praise or censure, and unconnected with any principles that could throw light on the arrangement of fields. The first writer who assigned due importance to the subject of rotations seems to have been the Rev. Adam Dickson, in his *Treatise on Agriculture*, published in Edinburgh in 1777; and soon afterwards Lord Kaimes, in his *Gentleman Farmer*, illustrates the importance of the subject: both writers were probably led to it by observing the effects of the Norfolk husbandry, then beginning to be introduced to Berwickshire. But whatever may have been the little attention paid to this subject by former writers, the importance of the subject of rotations, and the rule founded on the principles already laid down, that culmiferous crops ripening their seeds should not be repeated without the intervention of pulse, roots, herbage, or fallow, is now "recognised in the practice and writings of all judicious cultivators, more generally perhaps than any other." (*Edit. of Farmer's Mag.*)

4928. *The system of rotations* is adapted for every soil, though no particular rotation can be given for any one soil which will answer in all cases; as something depends on climate, and something also on the kind of produce for which there is the greatest market demand. But wherever the system of rotations is followed, and the several processes of labour which belong to it properly executed, land will rarely get into a foul and exhausted state, or at least, if foul and exhausted under a judicious rotation, "matters would be much worse were any other system followed."

4929. *The particular crops* which enter into a system of rotation must obviously be such as are suited to the soil and climate, though, as the experienced author so often quoted observes, "they will be somewhat varied by local circumstances, such as the proximity of towns and villages, where there is a greater demand for turnips, potatos, hay, &c. than in thinly peopled districts. In general, beans and clover, with rye-grass, are interposed between corn crops on clayey soils; and turnips, potatoes, and clover with rye-grass on dry loams and sands, or what are technically known by the name of turnip soils. A variety of

other plants, such as peas, tares, cabbages, and carrots, occupy a part, though commonly but a small part, of that division of a farm which is allotted to green crops. This order of succession is called the system of *alternate husbandry*; and on rich soils, or such as have access to abundance of putrescent manure, it is certainly the most productive of all others, both for food for man and for the inferior animals. One half of a farm is in this course always under some of the different species of cereal grasses, and the other half under pulse, roots, cultivated herbage, or plain fallow.

4930. *But the greater part of the arable land of Britain* cannot be maintained in a fertile state under this management; and sandy soils, even though highly manured, soon become too incohesive under a course of constant tillage. It therefore becomes necessary to leave that division or *break* that carries cultivated herbage to be pastured for two years or more, according to the degree of its consistency and fertility; and all the fields of a farm are treated thus in their turn if they require it. This is called the system of *convertible husbandry*, a regular change being constantly going on from aration to pasturage, and *vice versa*.

4931. *Not to repeat the same kind of crop at too short intervals*, is another rule with regard to the succession of crops. Whatever may be the cause, whether it is to be sought for in the nature of the soil or of the plants themselves, experience clearly proves the advantages of introducing a diversity of species into every course of cropping. When land is pastured several years before it is brought again under the plough, there may be less need for adhering steadily to this rule; but the degeneracy of wheat and other corn crops recurring upon the same land every second year for a long period, has been very generally acknowledged. It is the same with what are called green crops; beans and peas, potatoes, turnips, and in an especial manner red clover, become all of them much less productive, and much more liable to disease, when they come into the course, upon the same land, every second, third, or fourth year. But what the interval ought to be has not yet been ascertained, and, from the great number of years that experiments must be continued to give any certain result, probably cannot be determined until the component parts of soils, and particularly the sort of vegetable nourishment which each species of plant extracts from the soil, have been more fully investigated.

4932. *A change of variety* as well as of the species, and even of the plants of the same variety, is found to be attended with advantage; and in the latter case, or a change of seed, the species and variety being the same, the practice is almost universal. It is well known, that of two parcels of wheat, for instance, as much alike in quality as possible, the one which had grown on a soil differing much from that on which it is to be sown, will yield a better produce than the other that grew in the same or a similar soil and climate. The farmers of Scotland accordingly find that wheat from the south, even though it be not, as it usually is, better than their own, is a very advantageous change; and oats and other grain brought from a clayey to a sandy soil, other things being equal, are more productive than such as have grown on sandy soil. (*Supp. Encyc. Brit. art. Agr. 144.*)

4933. *The following are examples of rotations suited to different soils*, as given in Brown's excellent *Treatise on Rural Affairs*. The basis of every rotation, he says, "we hold to be either a bare summer fallow, or a fallow on which drilled turnips are cultivated, and its conclusion to be with the crops taken in the year preceding a return of fallow or drilled turnips, when of course a new rotation commences.

4934. *Rotation for strong deep lands*. According to this rotation, wheat and drilled beans are the crops to be cultivated, though clover and rye-grass may be taken for one year in place of beans, should such a variety be viewed as more eligible. The rotation begins with summer fallow, because it is only on strong deep lands that it can be profitably practised; and it may go on for any length of time, or so long as the land can be kept clean, though it ought to stop the moment that the land gets into a contrary condition. A considerable quantity of manure is required to go on successfully; perhaps dung should be given to each bean crop; and if this crop is drilled and attentively horse-hoed, the rotation may turn out to be one of the most profitable that can be exercised.

4935. *Rotation for loams and clays*. Where it may not be advisable to carry the first rotation into execution, a different one can be practised, according to which labour will be more divided, and the usual grains more generally cultivated; for instance, the following, which used to be common in East Lothian:—

- | | | |
|-----------------------------------|--------------------------|----------------------------------|
| 1. Fallow, with dung. | 4. Barley. | 7. Beans drilled and horse-hoed. |
| 2. Wheat. | 5. Clover and rye-grass. | 8. Wheat. |
| 3. Beans, drilled and horse-hoed. | 6. Oats or wheat. | |

This rotation is excellently calculated to insure an abundant return through the whole of it, provided dung is bestowed upon the clover stubble. Without this supply the rotation would be crippled, and inferior crops of course produced in the concluding years.

4936. *Rotation for clays and loams of an inferior description*. This rotation is calculated for soils of an inferior description to those already treated of.

- | | | |
|-----------------------|--------------------------|-----------------------------------|
| 1. Fallow, with dung. | 3. Clover and rye-grass. | 5. Beans, drilled and horse-hoed. |
| 2. Wheat. | 4. Oats. | 6. Wheat. |

According to this rotation, also in use in East Lothian, the rules of good husbandry are studiously practised; while the sequence is obviously calculated to keep the land in good order, and in such a condition as to ensure crops of the greatest value. If manure is bestowed either upon the clover-stubble or before the beans are sown, the rotation is one of the best that can be devised for the soils mentioned.

4937. *Rotation for thin clays*. On thin clays gentle husbandry is indispensably necessary, otherwise the soil may be exhausted, and the produce unequal to the expense of cultivation. Soils of this description will not improve much while under grass; but unless an additional stock of manure can be procured, there is a necessity of refreshing them in that way, even though the produce should in the mean time be comparatively of small value. The following rotation is not an improper one:—

- | | | |
|-----------------------|---|-----------|
| 1. Fallow, with dung. | 3. Grass pastured, but not too early eaten. | 5. Grass. |
| 2. Wheat. | 4. Grass. | 6. Oats. |

This rotation may be shortened or lengthened, according to circumstances, but should never extend further in point of ploughing than when dung can be given to the fallow-break. This is the keystone of the whole; and if neglected the rotation is rendered useless.

4938. *Rotation for peat earth soils*. These are not friendly to wheat, unless aided by a quantity of calcareous matter. Taking them in a general point of view, it is not advisable to cultivate wheat, but a crop of oats may almost be depended upon, provided the previous management has been judiciously executed. If the subsoil of peat earth lands is retentive of moisture, the process ought to commence with a bare summer fallow; but if such are incumbent on free and open bottoms, a crop of turnips may be substituted for fallow; according to which method, the surface will get a body which naturally it did not possess. Grass on such soils must always occupy a great space of every rotation, because physical circumstances render regular cropping utterly impracticable.

- | | | |
|----------------------------------|------------------------------------|-----------------------------------|
| 1. Fallow, or turnips with dung. | quantity of perennial rye- | circumstances permit the land to |
| 2. Oats of an early variety. | grass. | be broken up, when oats are to be |
| 3. Clover, and a considerable | 4. Pasture for several years, till | repeated. |

4939. *Rotation for light soils.* These are easily managed, though to procure a full return of the profit which they are capable of yielding, requires generally as much attention as is necessary in the management of those of a stronger description. Upon light soils, a bare summer fallow is seldom called for, as cleanliness may be preserved by growing turnips, and other leguminous articles. Grass also is of eminent advantage upon such soils, often yielding a greater profit than what is afforded by culmiferous crops.

- | | |
|-----------------------------|--------------------------|
| 1. Turnips. | 3. Clover and rye-grass. |
| 2. Spring wheat, or barley. | 4. Oats or wheat. |

This is a fashionable rotation; but it may be doubted whether a continuance of it for any considerable period is advisable, because both turnips and clover are found to fall off when repeated so often as once in four years. Common red clover will not grow every four years, unless gypsum be restored to the land. Perhaps the rotation would be greatly improved were it extended to eight years, whilst the ground, by such an extension, would be kept fresh and constantly in good condition. As, for instance, were seeds for pasture sown in the second year, the ground kept three years under grass, broke up for oats in the sixth year, drilled with beans and peas in the seventh, and sown with wheat in the eighth; the rotation would then be complete, because it included every branch of husbandry, and admitted a variety in management generally agreeable to the soil, and always favourable to the interest of cultivators. The rotation may also consist of six crops, were the land kept only one year in grass, though few situations admit of so much cropping, unless additional manure is within reach.

4940. *Rotation for sandy soils.* These, when properly manured, are well adapted to turnips, though it rarely happens that wheat can be cultivated on them with advantage, unless they are dressed with alluvial compost, marl, clay, or some such substances as will give a body or strength to them, which they do not naturally possess. Barley, oats, and rye, the latter especially, are, however, sure crops on sands, and in favourable seasons will return greater profit than can be obtained from wheat.

- | | |
|---|--------------------------|
| 1. Turnips well manured consumed on the ground. | 3. Clover and rye-grass. |
| 2. Barley sown with clover and rye-grass. | 4. Wheat, rye, or oats. |

By keeping the land three years in grass, the rotation would be extended to six years, a measure highly advisable."

4941. *These examples* are sufficient to illustrate the subject of improved rotations; but as the best general schemes may be sometimes momentarily deviated from with advantage, the same able author adds, that "cross cropping, in some cases, may perhaps be justifiable in practice; as, for instance, we have seen wheat taken after oats with great success, when these oats had followed a clover crop on rich soil; but, after all, as a general measure, that mode of cropping cannot be recommended. We have heard of another rotation, which comes almost under the like predicament; though, as the test of experience has not yet been applied, a decisive opinion cannot be pronounced upon its merits. This rotation begins with a bare fallow, and is carried on with wheat, grass for one year or more, oats, and wheat, where it ends. Its supporters maintain that beans are an uncertain crop, and cultivated at great expense; and that in no other way will corn, in equal quantity and of equal value, be cultivated at so little expense as according to the plan mentioned. That the expense of cultivation is much lessened, we acknowledge, because no more than seven ploughings are given through the whole rotation; but whether the crops will be of equal value, and whether the ground will be preserved in equally good condition, are points which remain to be ascertained by experience." (*Brown on Rural Affairs.*)

4942. *As a general guide to devising rotations on clay soils,* it may be observed, that winter or autumn sown crops are to be preferred to such as are put in in spring. Spring ploughing on such soils is a hazardous business, and not to be practised where it can possibly be avoided. Except in the case of drilled beans, there is not the slightest necessity for ploughing clays in the spring months; but as land intended to carry beans ought to be early ploughed, so that the benefit of frost may be obtained, and as the seed furrow is an ebb one, rarely exceeding four inches in deepness, the hazard of spring ploughing for this article is not of much consequence. Ploughing with a view to clean soils of the description under consideration has little effect, unless given in the summer months. This renders summer fallow indispensably necessary; and without this radical process, none of the heavy and wet soils can be suitably managed, or preserved in a good condition.

4943. *To adopt a judicious rotation of cropping for every soil,* requires a degree of judgment in the farmer, which can only be gathered from observation and experience. The old rotations were calculated to wear out the soil, and to render it unproductive. To take wheat, barley, and oats in succession, a practice very common thirty years ago, was sufficient to impoverish the best of land, while it put little into the pockets of the farmer; but the modern rotations, such as those which we have described, are founded on principles which ensure a full return from the soil, without lessening its value, or impoverishing its condition. Much depends, however, upon the manner in which the different processes are executed; for the best arranged rotation may be of no avail, if the processes belonging to it are imperfectly and unseasonably executed. (See 2221.) The best farmers in the northern counties now avoid over-cropping or treating land in any way so as to exhaust its powers, as the greatest of all evils.

SECT. II. *The working of Fallows.*

4944. *The practice of fallowing,* as we have seen in our historical view of Greek and Roman agriculture, has existed from the earliest ages; and the theory of its beneficial

effects we have endeavoured to explain. (2175.) The Romans with their agriculture introduced fallows in every part of Europe; and two crops, succeeded either by a year's fallow, or by leaving the land to rest for two or more years, became the rotation on all soils and under all circumstances. This mode of cultivating arable land is still the most universal in Europe, and was prevalent in Britain till the middle of the last century; but as a crop was lost every year they occurred, a powerful aversion from naked fallows arose about that time, and called forth numerous attempts to show that they were unnecessary, and consequently an immense public loss. This anti-fallowing mania, as it has been called, was chiefly supported by Arthur Young, Nathaniel Kent, and others, members or correspondents of the Board of Agriculture: it was at its greatest height about the beginning of the present century, but has now spent its force; and after exhausting all the arguments on both sides, as an able author has observed, "the practice does not appear to give way, but rather to extend."

4945. *The expediency or in expediency of pulverising and cleaning the soil by a bare fallow*, is a question that can be determined only by experience, and not by argument. No reasons, however ingenious, for the omission of this practice, can bring conviction to the mind of a farmer, who, in spite of all his exertions, finds, at the end of six or eight years, that his land is full of weeds, sour, and comparatively unproductive. Drilled and horse-hoed green crops, though cultivated with advantage on almost every soil are probably in general unprofitable as a substitute for fallow, and after a time altogether inefficient. It is not because turnips, cabbages, &c. will not grow in such soils, that a fallow is resorted to, but because, taking a course of years, the value of the successive crops is found to be so much greater, even though an unproductive year is interposed, as to induce a preference to fallowing. Horse-hoed crops, of beans in particular, postpone the recurrence of fallow, but in few situations can ever exclude it altogether. On the other hand, the instances that have been adduced, of a profitable succession of crops on soils of this description, without the intervention of a fallow, are so well authenticated, that it would be extremely rash to assert that it can in no case be dispensed with on clay soils. Instances of this kind are to be found in several parts of Young's *Annals of Agriculture*; and a very notable one, on Greg's farm of Coles, in Hertfordshire, is accurately detailed in the sixth volume of *The Communications to the Board of Agriculture*.

4946. *The principal causes of this extraordinary difference among men of great experience*, may probably be found in the quality of the soil, or in the nature of the climate, or in both. Nothing is more vague than the names by which soils are known in different districts. Greg's farm, in particular, though the soil is denominated "heavy arable land," and "very heavy land," is found so suitable to turnips, that a sixth part of it is always under that crop, and these are consumed on the ground by sheep; a system of management which every farmer must know to be altogether impracticable on the wet tenacious clays of other districts. It may indeed be laid down as a criterion for determining the question, that wherever this management can be profitably adopted, fallow, as a regular branch of the course, must be not less absurd than it is injurious, both to the cultivator and to the public. It is probable, therefore, that, in debating this point, the opposite parties are not agreed about the quality of the soil; and, in particular, about its property of absorbing and retaining moisture, so different in soils that in common language have the same denomination.

4947. *Another cause of difference* must be found in the climate. It is well known that a great deal more rain falls on the west than on the east coast of Britain; and that between the northern and southern counties there is at least a month or six weeks' difference in the maturation of the crops. Though the soil, therefore, be as nearly as possible similar in quality and surface, the period in which it is accessible to agricultural operations must vary accordingly. Thus, in the south-eastern counties of the island, where the crops may be all cut down, and almost all carried home by the end of August, much may be done in cleansing and pulverising the soil, during the months of September and October, while the farmers of the north are exclusively employed in harvest work, which is frequently not finished by the beginning of November. In some districts in the south of England, wheat is rarely sown before December; whereas in the north, and still more in Scotland, if it cannot be got completed by the end of October, it must commonly be delayed till spring, or oats or barley be taken in place of wheat. It does not then seem of any utility to enter farther into this controversy, which every skilful cultivator must determine for himself. All the crops, and all the modes of management which have been proposed as substitutes for fallow, are well known to such men, and would unquestionably have been generally adopted long ago, if, upon a careful consideration of the advantages and disadvantages on both sides, a bare fallow was found to be unprofitable in a course of years. The reader who wishes to examine the question fully may consult, among many others, the following:—Young's *Annals of Agriculture*, and his writings generally; Hunter's *Georgical Essays*; Dickson's *Practical Agriculture*; Sir H. Davy's *Agricultural Chemistry*; *The Agricultural Chemistry* of Chaptal; Brown's *Treatise on Rural Affairs*; *The County Reports*; *The General Report of Scotland*, and the *Quarterly Journal of Agriculture*, vol. ii. p. 90.

4948. *The importance of naked fallows* has been ably pointed out by a writer in the work last referred to. "In order," he says, "to show more forcibly the difficulty of cleaning heavy lands for green crops, let us take a review of the time of the year in which these crops should be sown. In clay lands, beans must be sown in March at latest, and before that period of the year no one can pretend to clean land at all. Finding it impossible to use them as a fallow crop, they are sown without dung on that part of the rotation which is penultimate to bare fallow. On light lands, beans will not carry much straw without manure, and their utility as a crop in the rotation is, of course, thereby much decreased on such soils; and if they are to be sown as a fallow crop with dung on the land that is to be appropriated to fallow, they give much less time for the preparatory cleaning of the land than turnips, as they must be sown at latest in April. On all kinds of soil potatoes must be planted by April; and the same observations will, therefore, apply to them as to beans as a cleaner of the land. It is only from their great value as human food, and from their inability to grow without dung, that they are planted as a fallow crop; because it is impracticable to keep land clean, and much more so to make it clean, under a potato fallow. Thus there is difficulty in cleaning land, without summer fallow, with beans and potatoes on every kind of soil in any spring, however favourable; and it is quite impossible to do so in a wet one. There is also difficulty in cleaning strong clay land even by turnip-time in May; and

the greatest facility which a farmer possesses of cleaning his land or keeping it clean, under a green crop, is by a turnip one, on a light soil resting on an open bottom, in a dry season. This last instance amounts, in fact, to all the boasted possibility of keeping land clean by green crops, without the assistance of bare fallow. But even this substitution is only an approximation to cleanliness; for every one knows, who has farmed light soils for a series of rotations, whatever his practice may be, that even the turnip crop cannot be raised on them for an indefinite period without the land getting foul with root-weeds, such as quicks and knot grass; and no better mode of extirpating these formidable robbers of the artificial nourishment of the cultivated crops, than by bare fallowing, has yet been discovered. They are the rooks of the soil. Indeed, the practice of the best farmers of light land, however great their desire to curtail the extent of bare fallow may be, is to have a portion of the land under fallow, though the extent of it may no doubt be limited by the want of manure, from a desire to keep their land clean; and this is accomplished by summer fallowing that portion of it which had carried potatoes in the preceding rotation, and raising the potatoes and turnips on that part which had been previously thoroughly cleaned by summer fallowing. This is a good practice, not only as a means of keeping land clean, but as following out that system of alternate husbandry of white and green crops, which has, by abolishing a succession of white crops with their scourging effects, tended more than any other to render the soil of these islands all alike fertile. But will summer fallow keep land clean? Undoubtedly it will, if properly performed. It gives the opportunity of working land in June and July, when every crop should be in the ground, and when the sun is so powerful, and the atmosphere so warm and dry, as to kill every plant that has not a hold of the ground. The process already described, of ploughing, harrowing, and rolling, according to the state of the ground, is admirably adapted for cutting the matted land in pieces, for shaking the detached lumps of earth asunder, and for bruising to powder every hardened ball of earth into which the fibres or roots of weeds might penetrate; and the hand-picking carries off every bit of weed which might possess any latent vegetative power. Land that cannot be cleaned under such favourable circumstances as to season, must be excessively foul, the season very wet and cold, or the fallowing process conducted with great slovenliness. It must be confessed, that fallowing is too often worked very negligently. It is thought by some, that the land can be cleaned at any time before seed-time in autumn; and other things of less importance too often attract the attention from the more important fallow; that weeds, though they do grow, can be easily ploughed down, and that the ploughing of them down assists to manure the land. Such thoughts too often prevail over better knowledge; and they furnish a strong argument in favour of increasing, rather than of diminishing, the means of cleanliness. But such thoughts display, in their effects, great negligence and ignorance: negligence, in permitting any weeds to cover the land, particularly the root-growing ones, by which the strength of the soil is exhausted, and in losing the most favourable part of the season to accomplish their destruction; and ignorance, in thinking that weeds ploughed down afford nourishment to the soil, when that soil has been exhausting itself in bearing the crop of weeds. These are facts which are known to every practical farmer, and the nature of which presses upon him a conviction of the necessity of summer fallowing more strongly than all the arguments that can be most speciously drawn, by analogy, from the practice of other arts. Reasoning from analogy is feeble when opposed to experience. Gardeners, no doubt, raise crops every year from the same piece of ground; but their practice is not quite analogous to that of the husbandman. They apply a great quantity of manure to the soil, and they permit few or no plants to run to seed, the bringing of which to perfection, in the cereal crops, constitutes the great exhaustion to the soil. Gardeners, however, do something like fallowing their ground at stated periods, as every three or four years they dig the ground a double spit of the spade in depth, and lay it up in winter to the frost; and they reserve alternate pieces of ground for the support of late crops; all which practices approach nearly to our ideas of summer fallowing." (*Quar. Jour. Ag.* vol ii. p.105.)

4949. *Fallows unnecessary on friable soils.* However necessary the periodical recurrence of fallow may be on retentive clays, its warmest advocates do not recommend it on turnip soils, or on any friable loams incumbent on a porous subsoil; nor is it in any case necessary every third year, according to the practice of some districts. On the best cultivated lands it seldom returns oftener than once in six or eight years; and in favourable situations for obtaining an extra supply of manure, it may be advantageously dispensed with for a still longer period. (*Suppl. to Encyc. Brit.* art. *Agr.*)

4950. *The operation of fallowing,* as commonly practised in England, is, in usefulness and effect, very different from what it ought to be. In most places the first furrow is not given till the spring, or even till the month of May or June; or, if it is given earlier, the second is not given till after midsummer, and on the third the wheat is sown. Land may rest under this system of management; but to clean it from weeds, to pulverise it, or to give it the benefits of aëration and heat, is impossible. The farmer in some cases purposely delays ploughing his fallows, for the sake of the scanty bite the couch and weeds afford to his sheep; and for the same reason, having ploughed once, he delays the second ploughing. It is not to be wondered at, that under such a system, the theoretical agriculturist should have taken a rooted aversion from what are thus erroneously termed fallows. The practice of the best farmers of the northern counties is very different, and that practice we shall here detail.

4951. *A proper fallow* invariably commences after harvest; the land intended to be fallowed getting one ploughing, which ought to be as deep as the soil will admit, even though a little of the till or subsoil is brought up. This both tends to deepen the cultivated, or manured, soil, as the fresh accession of hitherto uncultivated earth becomes afterwards incorporated with the former manured soil, and greatly facilitates the separation of the roots of weeds during the ensuing fallow process, by detaching them completely from any connection with the fast subsoil. This autumnal ploughing, usually called the winter furrow, promotes the rotting of stubble and weeds; and, if not accomplished towards the end of harvest, must be given in the winter months, or as early in the spring as possible. In giving this first ploughing, the old ridges should be gathered up, if practicable, as in that state they are kept dry during the winter months; but it is not uncommon to split them out or divide them, especially if the land had been previously highly gathered, so that each original ridge of land is divided into two half ridges. Sometimes, when the land is easily laid dry, the furrows of the old ridges are made the crowns of the new ones, or the land is ploughed in the way technically called *crown-and-furrow*. In other instances, two ridges are ploughed together, by what is called *casting*, which has been already described. After the field is ploughed, all the inter-furrows, and those of the headlands, are carefully opened up by the plough, and are afterwards gone over effectually by a labourer with a spade, to remove all obstructions, and to open up the water furrows into the fence ditches, wherever that seems necessary, that all moisture may have a ready exit. In every place where water is expected to lodge, such as *dishes*, or hollow places in the field, cross or oblique furrows are drawn by the plough, and their intersections carefully opened into each other by the spade. Wherever it appears necessary, cross cuts are also made through the head ridges into the ditches with a spade, and every possible attention is exerted, that no water may stagnate in any part of the field.

4952. *As soon as the spring seed-time is over,* the fallow land is again ploughed end-long. If formerly split, it is now ridged up; if formerly laid up in gathered ridges, it is split or cloven down. It is then

cross-ploughed; and after lying till sufficiently dry to admit the harrows, it is harrowed and rolled repeatedly, and every particle of the vivacious roots of weeds brought up to view, carefully gathered by hand into heaps, and either burnt on the field, or carted off to the compost heap. The fallow is then ridged up, which places it in a safe condition in the event of bad weather, and exposes a new surface to the harrows and roller; after which the weeds are again gathered by hand, but a previous harrowing is necessary. It is afterwards ploughed, harrowed, rolled, and gathered as often as it may be necessary to reduce it into fine tilth, and completely to eradicate all root-weeds. Between these successive operations, repeated crops of seedling weeds are brought into vegetation, and destroyed. The larvæ likewise of various insects, together with an infinite variety of the seeds of weeds, are exposed to be devoured by birds, which are then the farmer's best friends, though often proscribed as his bitterest enemies.

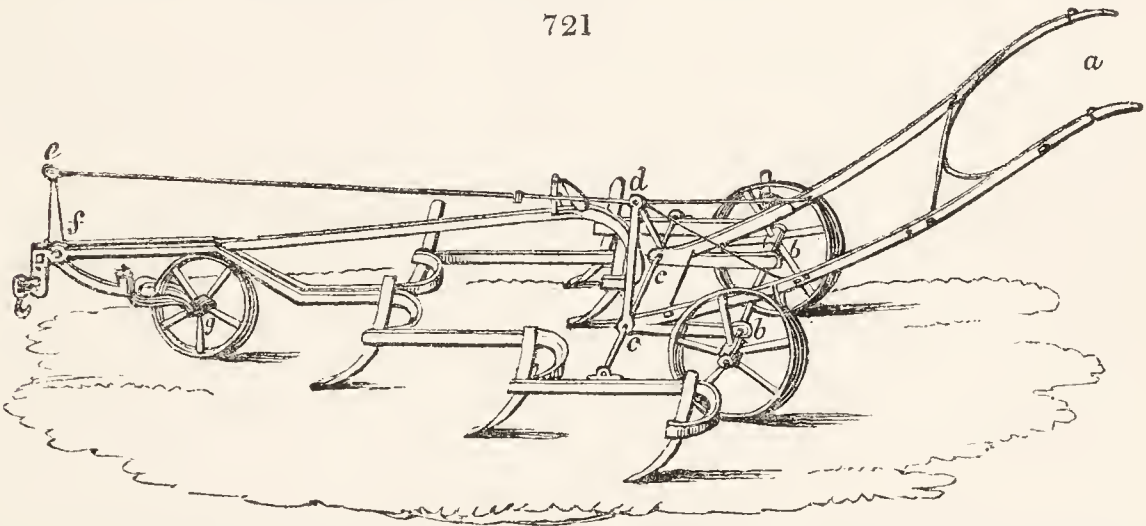
4953. *The use of the harrow and roller in the fallow process*, has been condemned by some writers on husbandry, who allege that frequent ploughing is all that is necessary to destroy root-weeds, by the baking or drying of the clods in the sun and wind; but experience has ascertained, that frequently turning over the ground, though absolutely necessary while the fallow process is going on, can never eradicate couch-grass or other root-weeds. In all clay soils, the ground turns up in lumps or clods, which the severest drought will not penetrate so sufficiently as to kill the included roots. When the land is again ploughed, these lumps are turned over and no more, and the action of the plough serves in no degree to reduce them, or at least very imperceptibly. It may be added, that these lumps likewise enclose innumerable seeds of weeds, which cannot vegetate unless brought under the influence of the sun and air near the surface. The diligent use, therefore, of the harrow and roller, followed by careful hand-picking, is indispensably necessary to the perfection of a fallow process. (*General Report of Scotland*, vol. iv. p. 419.)

4954. *The working of fallows by the grubber*, is an important modern improvement. We have already described several of these implements, and shall here introduce one which has been made public since the first five hundred pages of this work were printed.

4955. *Kirkwood's improved grubber* (fig. 721.) has this peculiar advantage, that "the whole of the body of the instrument, and of course all the teeth, can be raised out of the ground at pleasure, and even while the machine is in motion; which is extremely convenient, not only in turning at the head ridges,

but whenever an obstruction is met with in the ground, arising from rocky, retentive, or other impenetrable soils. In such of these as would completely interrupt the progress of the ordinary instrument, this proceeds with ease, by merely being lifted more or less over them. The operation is performed by the driver bearing with his weight on the guiding handles of the grubber; and this pressure is made to raise the whole machine by a very skilful application of mechanical power. The pressure on the guiding handles (*a*), it will be observed, turns the whole handle round the axle of the hind wheels (*b b*), as round a fulcrum, so that the handle then becomes a lever, on the shorter extremity of which the frame of the teeth rests. It is evident, therefore, that by bearing on the handle which forms the long end of the lever, the shorter end must be raised, and along with it the hinder part of the teeth-frame, and, of course, the teeth also. But there is still another contrivance, by which the force is made to act at the same time on the forepart of the frame, and to raise it likewise. This is done by a long rod (*d e*), which is attached at the extremity to a fulcrum (*d*), raised on the handle frame, and at the other to the one end of a bent lever (*e f g*), which turns on the axle of the fore wheel as a centre, and at an intermediate point carries the fore end of the teeth frame. While the handle, therefore, is depressed, and raises the hinder part of this frame, it at the same time pulls the rod, turns the front lever round the axle of the fore wheel, and by this means elevates the teeth before as well as behind. The whole operation is simple, ingenious, and efficient." (*Higl. Soc. Trans.* vol. viii. p. 132.)

721



4956. *When effectually reduced to fine tilth*, and thoroughly cleaned from roots and weeds, the fallow is ploughed end-long into gathered ridges or lands, usually fifteen or eighteen feet broad. If the seed is to be drilled, the lands or ridges are made of such widths as may suit the construction of the particular drill-machine to be employed. If the seed is to be sown by hand, the lands or ridges are commonly formed into what are called single or double cast ridges; the first of four paces or steps, and the latter of eight steps in width. These widths are found the most convenient for a one-handed sower. An expert sower can, however, measure his handful to almost any width; but the above long experience has made the standard. After the land has been once gathered by a deep furrow, proportioned to the depth of the cultivated soil, the manure is laid on, and evenly spread over the surface, whether muck, lime, marl, or compost. A second gathering is now given by the plough; and this being generally the furrow upon which the seed is sown, great care is used to plough as equally as possible. After the seed is sown and the land thoroughly harrowed, all the inter-furrows, furrows of the headlands, and oblique or *gaw* furrows, are carefully opened up by the plough, and cleared out by the spade, as already mentioned, respecting the first or winter ploughing.

4957. *The expense of fallowing* may appear, from what has been said, to be very considerable, when land has been allowed to become stocked with weeds; but if it be kept under regular management, corn alternating with drilled pulse or green crops, the subsequent returns of fallow will not require near so much labour. In common cases, from four to six ploughings are generally given, with harrowing and rolling between, as may be found necessary; and, as we have already noticed, the *cultivator* may be employed to diminish this heavy expense. But it must be considered, that upon the manner in which the fallow operations are conducted, depend not only the ensuing wheat crop, but in a great measure all the crops of the rotation. (*Supp. to Encyc. Brit.* art. *Agr.* 128.)

SECT. III. *General Management of Manures.*

4958. *The manures of animal, vegetable, or mineral origin* have been already described, and their operation explained. (2224.) But a very few of these substances can be obtained by farmers in general; whose standard resources are farm-yard dung and lime, and composts of these with earth. It is on the management of these that we propose to deliver the practice of the best British farmers.

SUBJECT. 1. *Management of Farm-yard Dung.*

4959. *The basis of farm-yard dung* is straw, to which is added, in its progress through the farm-yard, the excrementitious substances of live stock. From every ton of dry straw, about three tons of farm-yard dung may be obtained, if the after-management be properly conducted; and, as the weight of straw per acre runs from one ton to one and a half, about four tons of dung, on an average of the different crops, may be produced from the straw of every acre under corn. (*Husbandry of Scotland*, vol. ii.) Hence (it may be noticed) the great importance of cutting corn as low as possible; a few inches at the root of the stalk weighing more than double the same length at the ear.

4960. *The conversion of straw into farm-yard dung* in the farmery, is thus effected:—The straw is served out to cattle and horses in the houses and fold-yards, either as provender or litter, and commonly for both purposes; turnips in winter, and green clover in summer, are given to the stock both in the houses and yards: on this food the animals pass a great deal of urine, and afford the means of converting the straw into a richer manure than if it were eaten alone. All the dung from the houses, as they are cleaned out, is regularly spread over the yards in which young cattle are left loose, where litter is usually allowed in great abundance; or over the dunghill itself, if there is one at hand. This renders the quality of the whole mass more uniform; and the horse-dung, which is of a hot nature, promotes the decomposition of the woody fibres of the straw.

4961. *The preparation of the contents of the farm-yard* for laying on the land, is by turning it over; or, what is preferable, carting it out to a dunghill. The operation of carting out is usually performed during the frosts of winter: it is then taken to the field in which it is to be employed, and neatly built in dunghills of a square form, three or four feet high, and of such a length and breadth as circumstances may require. What is laid up in this manner early in winter, is commonly sufficiently prepared for turnips in June; but if not carried from the straw-yards till spring, it is necessary to turn it once or oftener, for the purpose of accelerating the decomposition of the strawy part of the mass. When dung is applied to fallows in July or August, preparatively to autumn-sown wheat, a much less degree of putrefaction will suffice than for turnips: a clay soil, on which alone fallows should ever be resorted to, not requiring dung so much rotted as a finely pulverised turnip soil; and besides, as the wheat does not need all the benefit of the dung for some time, the woody fibre is gradually broken down in the course of the winter, and the nourishment of the plants continued till spring, or later, when its effects are most beneficial.

4962. *Management of stable dung.* There is a most valuable paper on this subject by Lord Meadowbank, in the second volume of the *Com. to the Board of Agr.* “His lordship has ever found, that, instead of dung being the richest manure when completely fermented, it should, if possible, be laid on when very imperfectly fermented, but nevertheless when the process is going on at such a rate as that it must continue after mixture with the soil till it is completed. Every gardener knows, that the dung used in hot-beds has little effect in comparison of fresh dung; and every farmer knows, that a dunghill, which has by any accident been kept for years, is of little more value than so much very rich earth. Every person of attention, too, must have remarked the great effects which ensue from turning over a dunghill recently before using it, and that composts operate most powerfully, if used when sensibly hot, from the activity of the fermentation which the recent mixture of the ingredients has occasioned, and when, consequently, that process is very far from being completed.” As farm dunghills are formed by degrees, it is desirable to retard the fermentation of that which is first made, or to retain it in a state of fermentation, “so slow or imperfect, that it may suffer little till after being turned over with the later made dung, it forms one powerfully fermenting mass; and that then it should be put into the soil, when the process is so far advanced that it will be completed, when, at the same time, little loss of substance has yet been suffered, and when what volatile matter is afterwards extricated will diffuse itself through the soil. In these circumstances, every thing is lodged in the soil that the dung can yield, either in point of mass or activity; and at the same time it is in a state when most likely to act as a powerful ferment, for promoting the putrefaction of the decayed vegetables lying inert in the soil. I certainly, therefore, approve of the preservation of dunghills from much sun and much wind, as well as from that redundancy of moisture which is apt to overflow and wash away the manure; but I think the pressure which the feet of animals give them, especially of the lighter sort, does good, and prevents that violent fermentation which wastes the substance, and, in my opinion, exhausts the fertilising powers of dung. This pressure contributes to preserve it fresh till the time of employing it as a manure calls for putting it altogether, and at once, into that highly active state of putrefaction, which, though no doubt checked by its distribution in the soil, is sufficient to ensure a gradual and complete dissolution and diffusion of its substance. Unless, therefore, dung is to be used for composts, it appears to me clearly advantageous to get the dung into the soil as early as possible; it is always wasting somewhat, when kept out of it: but when put into the soil in a proper state, there is the utmost reason to think that what is extricated goes all to fertilise. Give me leave to add, that I do not believe much is lost by dissolution in rain water. I could never discover any thing of the kind in the water of the furrows of a field properly manured and ploughed. The case, every person knows, is quite different in fields recently limed or dressed with ashes; but I am apt to think, that the volatile and soluble parts of common dunghills have some attraction with the substance of soils, that prevents their escape. We know that common loam extracts the noisome smell of the woollen cloths used for intercepting the coarser oils that accompany spirits distilled from the sugar-cane, which scarce any detergent besides can obtain from it; and garden loam, impregnated as it must be with fermented dung, is certainly not easily deprived of its fertility by the washing of rain. I must also observe, that I take one of the great advantages derived from using dung with composts to be, the arresting and preserving the fertilising matter which escapes in the putrefactive fermentation; and another to be, that dung there operates as a ferment, to putrefy substances not sufficiently disposed to putrefy with activity of themselves. You will observe, that this coincides exactly with the effects I have attributed to it upon soil, and affords a very useful corollary with respect to the substances to be used in top-dressings, which are not to be covered with soil; viz. that if fermenting or putrefying substances are used, the process should have been completed, or nearly so, in a combination that has received the full benefit of it: that it is a great waste to spread common dung on grass, without having first mixed it with sand, loam, or other matter in which it has been dissolved and fixed; so that when spread on the ground, the loss, which would otherwise arise from fermentation and evaporation, is avoided; and that, if such a compost is used at the time when the plants are in a growing state, and in a way to cover it soon, it is by far the most advantageous method of laying it on.” (*Comm. B. Agr.* vol. ii. p. 387.)

4963. *The husbandman of Brabant* is careful that his manure should never become parched and dried up, by which means all the volatile salts would evaporate. He lays his dung, as often as possible, close to his stables and cow-houses, and sheltered from the sun. If this cannot be avoided, he contrives to lay it under some large tree, to partake of the shade of its boughs. As a receptacle for their dung, they generally dig a pit, five or six feet deep, with sufficient dimensions for the necessary deposit, from the month of March till harvest is over. The more opulent farmers are not satisfied with merely digging such a pit: they further pave and line it with bricks, that the earth should not absorb any of its parts; but that the thick matter should remain plunged in a mass of stale, increased further by rain. The stables and cow-houses are paved and sloped in such a manner as to communicate with a drain, which conveys all

the stale of their cattle towards the dung pit, which, by this contrivance, it keeps constantly supplying." (*Comm. B. Agr.* vol. ii.)

4964. *In the application of farm-yard dung to land under tillage*, particular attention is paid to the cleanness of the soil; and to use it at a time when, from the pulverisation of the ground, it may be most intimately mixed with it. The most common time of manuring with farm-yard dung is, therefore, either towards the conclusion of the fallowing operations, or immediately before the sowing of fallow crops. If no dung can be procured but what is made from the produce of the farm, it will seldom be possible to allow more than ten or twelve tons to every acre, when the land is managed under a regular course of white and green crops; and it is thought more advantageous to repeat this dose at short intervals, than to give a larger quantity at once, and at a more distant period in proportion. (*General Report of Scotland*, vol. ii. p. 517.) Farm-yard dung, it is well known, is greatly reduced in value by being exposed to the atmosphere in small heaps, previously to being spread, and still more after being spread. Its rich juices are exhaled by the sun, or washed away by the rains, and the residuum is comparatively worthless. This is in an especial manner the case with long fresh dung, the far greater part of which consists of wet straw in an entire state. All careful farmers, accordingly, spread and cover in their dung with the plough, as soon as possible after it is brought on the land.

4965. *The use of fresh dung* is decidedly opposite to the practice of the best farmers of turnip soils; its inutility, or rather injurious effects, from its opening the soil too much, is a matter of experience with every one who cultivates drilled turnips on a large scale. As the whole farm-yard dung, on such land, is applied to the turnip crop, it must necessarily happen that it should be laid on in different stages of putrefaction; and what is made very late in spring, often after a very slight fermentation, or none at all. The experience of the effect of recent dung is accordingly very general, and the result, in almost every case, is, that the growth of the young plants is slow; that they remain long in a feeble and doubtful state; and that they seldom, in ordinary seasons, become a full crop, even though twice the quantity that is given of short muck has been allowed. On the other hand, when the manure is considerably decomposed, the effects are immediate, the plants rise vigorously, and soon put forth their rough leaf, after which the beetle or fly does not seize on them; and in a few weeks, the leaves become so large, that the plants probably draw the greatest part of their nourishment from the atmosphere. Though it were true, therefore, that more nutritive matter is given out by a certain quantity of dung, applied in a recent state, and allowed to decompose gradually in the soil, than if applied after undergoing fermentation and putrefaction, the objection arising from the slowness of its operation would, in many instances, be an insuperable one with farmers. But there seems reason to doubt if fresh strawy manure would ferment much in the soil, after being spread out in so small a quantity as has been already mentioned; and also if, in the warm dry weather of summer, the shallow covering of earth given by the plough would not permit the gaseous matters to escape to a much greater amount than if fermentation had been completed in a well-built covered dunghill.

4966. *Another great objection to the use of fresh farm-yard dung* is, that the seeds and roots of those plants with which it commonly abounds spring up luxuriantly on the land; and this evil nothing but a considerable degree of fermentation can obviate. The mass of materials consists of the straw of various crops, some of the grains of which, after all the care that can be taken, will adhere to the straw; of the dung of different animals voided, as is often the case with horses fed on oats, with the grain in an entire state; and of the roots, stems, and seeds of the weeds that had grown among the straw, clover, and hay, and such as had been brought to the houses and fold-yards with the turnips and other roots given to live stock.

4967. *The degree of decomposition to which farm-yard dung should arrive*, before it can be deemed a profitable manure, must depend on the texture of the soil, the nature of the plants, and the time of its application. In general, clayey soils, as more tenacious of moisture, and more benefited by being rendered incohesive and porous, may receive manure less decomposed than well pulverised turnip soils require. Some plants, too, seem to thrive better with fresh dung than others, potatoes in particular; but all the small-seeded plants, such as turnips, clover, carrots, &c. which are extremely tender in the early stage of their growth, require to be pushed forward into luxuriant vegetation with the least possible delay, by means of short dung.

4968. *The season when manure is applied*, is also a material circumstance. In spring and summer, whether used for corn or green crops, the object is to produce an immediate effect, and it should therefore be more completely decomposed than may be necessary when laid on in autumn for a crop whose condition will be almost stationary for many months. (*Sup. Ency. Brit.* art. *Agr.*)

4969. *The quantity of putrescent manure* requisite for each acre of land during each year is estimated, by Professor Coventry, at five tons per acre annually. That quantity being supplied, not annually, but in quantities of twenty tons per acre every four years, or twenty-five tons per acre every five years. (*Quar. Jour. Agr.* vol. ii. p. 335.)

SUBJECT. 2. *Lime, and its Management as a Manure.*

4970. *Lime is by far the most important of the fossil manures*; and, indeed, it may be asserted, that no soil will ever be fit for much which does not contain a proportion of this earth, either naturally or by artificial application. Next to farm-yard dung, lime is in most general use as a manure, though it is one of a quite different character; and when judiciously applied, and the land laid to pasture, or cultivated for white and green crops alternately, with an adequate allowance of putrescent manure, its effects are much more lasting, and, in many instances, still more beneficial, than those of farm-yard dung. Fossil manures, Sir H. Davy observes, must produce their effect, either by becoming a constituent part of the plant, or by acting upon its more essential food, so as to render it more fitted for the purposes of vegetable life. It is, perhaps, in the former of these

ways that wheat and some other plants are brought to perfection, after lime has been applied, upon land that would not bring them to maturity by the most liberal use of dung alone. This being an established fact may be considered one of the greatest importance to all cultivators.

4971. *With regard to the quantity of lime that ought to be applied to different soils, it is much to be regretted that Sir Humphry Davy has not thought proper to enter fully into the subject.* Clays, it is well known, require a larger quantity than sands or dry loams. It has been applied accordingly in almost every quantity from 100 to 500 bushels or upwards per acre. About 160 bushels are generally considered a full dressing for lighter soils, and 80 or 100 bushels more for heavy cohesive soils. One of the greatest advantages arising from the use of lime on gravelly or sandy soils, is its power of absorbing moisture from the air, which is in the highest degree useful to the crops in dry summers.

4972. *In the application of lime to arable land, there are some general rules commonly attended to by diligent farmers, which we shall give nearly in the words of a recent publication.*

1. As the effects of lime greatly depend on its intimate admixture with the surface soil, it is essential to have it in a powdery state at the time it is applied.

2. Lime having a tendency to sink in the soil, it should be ploughed in with a shallow furrow.

3. Lime may either be applied to grass land, or to land in preparation for green crops or summer fallow, with almost equal advantage; but, in general, the latter mode of application is to be preferred.

4. Lime ought not to be applied a second time to moory soils, unless mixed up as a compost, after which the land should be immediately laid down to grass.

5. Upon fresh land, the effect of lime is much superior to that of dung. The ground, likewise, more especially where it is of a strong nature, is more easily wrought; in some instances, it is said, the saving of labour would be sufficient to induce a farmer to lime his land, were no greater benefit derived from the application than the opportunity thereby gained of working it in a more perfect manner. (*General Report of Scotland*, vol. ii. p. 536.)

4973. *In liming for improving hilly land, with a view to pasture, a much smaller quantity has been found to produce permanent and highly beneficial effects, when kept as much as possible near the surface, by being merely harrowed in with the seeds, after a fallow or green crop, instead of being buried by the plough.*

4974. *The successful practice of one of the most eminent farmers in Britain cannot be too generally known in a matter of so great importance to farmers of such land, especially when lime must be brought from a great distance, as was the case in the instance to which we are about to allude. "A few years after 1754," says Dawson, "having a considerable extent of outfield land in fallow, which I wished to lime previously to its being laid down to pasture, and finding that I could not obtain a sufficient quantity of lime for the whole in proper time, I was induced, from observing the effects of fine loam upon the surface of similar soil, even when covered with bent, to try a small quantity of lime on the surface of this fallow, instead of a larger quantity ploughed down in the usual manner. Accordingly, in the autumn, about twenty acres of it were well harrowed, and then about fifty-six Winchester bushels only of unslacked lime were, after being slacked, carefully spread upon each English acre, and immediately well harrowed in. As many pieces of the lime, which had not been fully slacked at first, were gradually reduced to powder by the dews and moisture of the earth, to mix these with the soil, the land was again well harrowed in three or four days thereafter. This land was sown in the spring with oats, with white and red clover and ryegrass seeds, and well harrowed, without being ploughed again. The crop of oats was good; the plants of grass sufficiently numerous and healthy; and they formed a very fine pasture, which continued good until ploughed some years after for corn. About twelve years afterwards, I took a lease of the hilly farm of Grubbet; many parts of which, though of an earthy mould tolerably deep, were too steep and elevated to be kept in tillage. As these lands had been much exhausted by cropping, and were full of couch-grass, to destroy that and procure a cover of fine grass, I fallowed them, and laid on the same quantity of lime per acre, then harrowed, and sowed oats and grass seeds in the spring exactly as in the last-mentioned experiment. The oats were a full crop, and the plants of grass abundant. Several of these fields have been now above thirty years in pasture, and are still producing white clover, and other fine grasses; no bent or fog has yet appeared upon them. It deserves particular notice, that more than treble the quantity of lime was laid upon fields adjoining, of a similar soil, but which being fitter for occasional tillage, upon them the lime was ploughed in. These fields were also sown with oats and grass seeds. The latter thrived well, and gave a fine pasture the first year; but afterwards the bent spread so fast, that, in three years, there was more of it than of the finer grasses."*

4975. *The conclusions which Dawson draws from his extensive practice in the use of lime and dung, deserve the attention of all cultivators of similar land.*

1. That animal dung dropped upon coarse benty pastures, produces little or no improvement upon them; and that, even when sheep or cattle are confined to a small space, as in the case of folding, their dung ceases to produce any beneficial effect, after a few years, whether the land is continued in pasture, or brought under the plough.

2. That even when land of this description is well fallowed and dunged, but not limed, though the dung augments the produce of the subsequent crop of grain, and of grass also for two or three years, that thereafter its effects are no longer discernible either upon the one or the other.

3. That when this land is limed, if the lime is kept upon the surface of the soil, or well mixed with it, and then laid down to pasture, the finer grasses continue in possession of the soil, even in elevated and exposed situations, for a great many years, to the exclusion of bent and moss. In the case of Grubbet hills, it was observed, that more than thirty years have now elapsed. Besides this, the dung of the animals pastured upon such land adds every year to the luxuriance, improves the quality of the pasture, and augments the productive powers of the soil when afterwards ploughed for grain; thus producing, upon a benty outfield soil, effects similar to what are experienced when rich infield lands have been long in pasture, and thereby more and more enriched.

4. That when a large quantity of lime is laid on such land, and ploughed down deep, the same effects will not be produced, whether in respect to the permanent fineness of the pasture, its gradual amelioration by the dung of the animals pastured on it, or its fertility when afterwards in tillage. On the contrary, unless the surface is fully mixed with lime, the coarse grasses will in a few years regain possession of the soil, and the dung thereafter deposited by cattle will not enrich the land for subsequent tillage.

Lastly. It also appears from what has been stated, that the four-shift husbandry is only proper for very rich land, or in situations where there is a full command of dung. That by far the greatest part of the land of this country requires to be continued in grass two, three, four, or more years, according to its

natural poverty; that the objection made to this, viz. that the coarse grasses in a few years usurp possession of the soil, must be owing to the surface soil not being sufficiently mixed with lime, the lime having been covered too deep by the plough. (*Farmer's Magazine*, vol. xiii. p. 69.)

SECT. IV. *Composts and other Manures.*

4976. *Mixing farm-yard dung, in a state of fermentation, with earth*, in which there is much inert vegetable matter, — as the banks of old ditches, or what is collected from the sides of lanes, &c., — will bring this inert, dead matter, consisting of the roots of decayed grasses and other plants, into a state of putridity and solubility, and prepare it for nourishing the crops or plants it may be applied to, in the very manner it acts on peat. Dung, however, mixed with earth, taken from rich arable fields which have been long cultivated and manured, can have no effect as manure to other land that the same earth and dung would not produce applied separately; because there is generally no inert matter in this description of earth to be rendered soluble.

4977. *Mixing dung, earth, and quick-lime together*, can never be advisable; because quick-lime will render some of the most valuable parts of the dung insoluble. (See 2290.) It will depend on the nature of soil or earth, whether even quick-lime only should be mixed with it to form compost. If there be much inert vegetable matter in the earth, the quick-lime will prepare it for becoming food for the plants it may be applied to; but if rich earth be taken from arable fields, the bottoms of dung-pits, or, in fact, if any soil full of soluble matter be used, the quick-lime will decompose parts of this soluble matter, combine with other parts, and render the whole mass less nourishing as manure to plants or crops than before the quick-lime was applied to it. Making composts, then, of rich soil of this description, with dung or lime, mixed or separate, is evidently, to say no more of it, a waste of time and labour. The mixture of earths of this description with dung produces no alteration in the component parts of the earth, where there is no inert vegetable substances to be acted on; and the mixture of earth full of soluble matter with dung and quick-lime, in a mass together, has the worst effects, the quick-lime decomposing and uniting with the soluble matter of the earth, as well as that of the dung; thus rendering both, in every case, less efficient as manures, than if applied separately from the quick-lime, and even the quick-lime itself inferior as manure for certain soils, than if it had never been mixed with the dung and earth at all. (*Farmer's Magazine*, vol. xv. p. 351.)

4978. *Mixing dung in a state of fermentation with peat*, or forming what in Scotland are called Meadowbank middens (2241.), is a successful mode of increasing the quantity of putrescent manure. The peat, being dug and partially dried, may either be carted into the farm-yard and spread over the cattle court, there to remain till the whole is carted out and laid upon a dunghill to ferment; or it may be mixed up with the farm-yard dung as carted out. If care be taken to watch the fermenting process, as the fire of a clay-kiln is watched, a few loads of dung may be made to rot many loads of peat. Adding lime to such composts does not in the least promote fermentation, while it renders the most valuable parts of the mass insoluble. Adding sand, ashes, or earth, will, by tending to consolidate the mass, considerably impede the progress of fermentation.

4979. *Bone manure.* Crushed bones were first introduced to Lincolnshire and Yorkshire, about 1800, by a bone merchant at Hull; and the effect has been, according to a writer in the *British Farmer's Magazine*, vol. iii. p. 207., to raise wild unenclosed sheep-walks from 2s. 6d. or 5s. to 10s. 6d. or 20s. an acre. The quantity at present laid on is 12 bushels per acre drilled in, in the form of dust, with turnip seed. The turnips are fed off with sheep, and succeeded by a corn crop, and by two crops of grass. It seems to be generally admitted, that bone dust is not beneficial on wet retentive soils, as continued moisture prevents decomposition; but in all descriptions of dry soils it never fails of success. On the poor soil, or chalk or lime-stone of the woolds of Lincolnshire and Yorkshire, the turnip crops are said to equal those of any part of England; and the barley, though coarse, to produce a greater quantity of saccharine matter than even the brightest Norfolk samples. (*Brit. Farm. Mag.* vol. iii. p. 208.)

4980. *The Doncaster Agricultural Association* appointed a committee, in 1828, to make enquiries, and report the result of them, on the use and advantages of bones as a manure. The report is full of interest, and highly satisfactory as to the great value of this species. The following is a summary of deductions from the details collected: —

1. That on dry sands, lime-stone, chalk, light loams, and peat, bones form a very highly valuable manure; they may be laid on grass with great good effect; and, on arable lands, they may be laid on fallow for turnips, or used for any of the subsequent crops.

2. That the best method of using them, when broad-cast, is previously to mix them up with earth, dung, or other manures, and let them lie to ferment.

3. That if used alone, they may either be drilled with the seed or sown broad-cast.

4. That bones which have undergone the process of fermentation are decidedly superior to those which have not done so.

5. That the quantity should be about 25 bushels of dust, or 40 bushels of large, increasing the quantity if the land be impoverished.

6. That upon clays and heavy loams, it does not yet appear that bones will answer.

4981. *Salt, nitre, and other manures* have been already treated of in Part II. at sufficient length. It is clear that both salt and nitre may be advantageously used in many cases. Nitre continues to be a good deal used in Hertfordshire, on which it is sown at the rate of $1\frac{1}{2}$ cwt. per acre. It has been tried at this rate in Scotland to wheat and to grass, and the effect is said to have been wonderful. Salt has been extensively used with almost every crop at different rates, from 20 to 40 bushels per acre; and it appears in many, if not in most, cases to have proved useful. (*Quar. Jour. Agr.* vol. i. p. 208., and *Highl. Soc. Trans.* vol. i. p. 147.)

CHAP. II.

Culture of the Cereal Grasses.

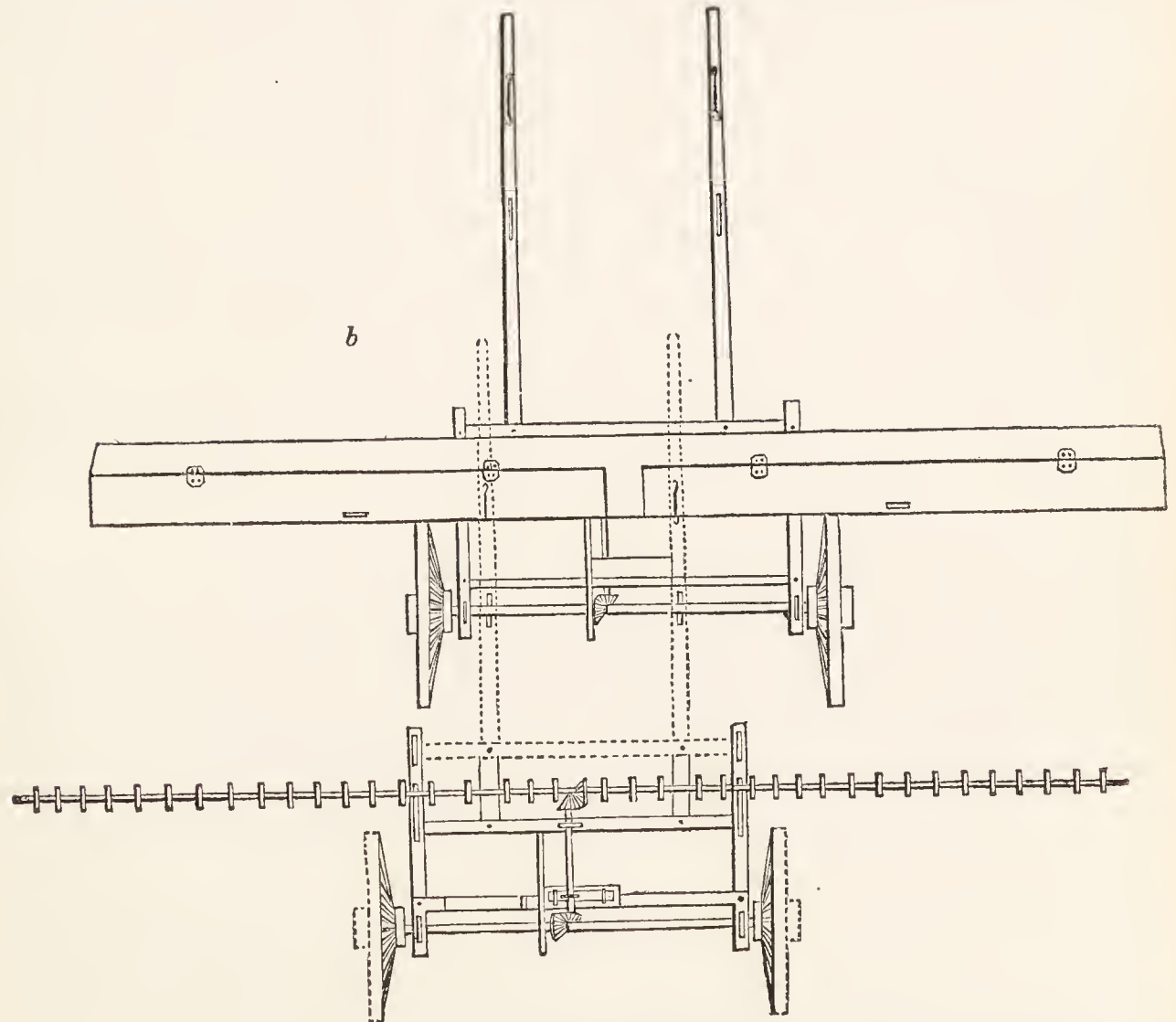
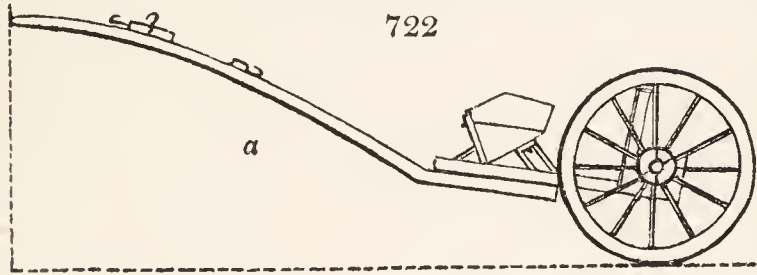
4982. *The corn crops* cultivated in Britain are, wheat, rye, barley, and oats. Other culmiferous plants, as the maize, millet, and rice, have been tried with partial success in warm districts, but they have no chance of ever becoming general in our climate. The best description of the different species and varieties of *Cerealia* cultivated in Europe will be found in Metzger's *Europäische Cerealien in Botanischer und Landwirthschaftlicher Hinsicht, &c.* Heidelberg, 1824. Folio, 20 plates. The plates are exceedingly well executed; and there are popular as well as scientific descriptions, with synonyms in all the European languages.

4983. *On the culture of culmiferous plants*, a few general remarks may be of use to the young farmer. Culmiferous plants, particularly wheat and rye, like most others, have two sets of roots. The first originate with the germination of the grain, are always under the soil, and are called the seminal roots; the second spring from the first joint which is formed near the surface of the soil, and from that joint strike down into the soil; these are called the coronal roots. The coronal roots appear chiefly intended for drawing nourishment from the soil; and, as Professor Martyn has observed, are judiciously placed for this purpose, the richest part of all soils being on or near the surface. These fibres are of larger diameter, more succulent, and never so long as the seminal. From these facts, as to the roots of culmiferous plants, some important hints may be derived regarding their culture. The use of stirring the surface in spring to facilitate the extension of the coronal roots, is obvious; the immediate effect of a top-dressing is also apparent, and also that manures may be ploughed in too deep to give the full amount of their beneficial effects to corn crops or grasses. Sageret, a scientific French agriculturist, proved experimentally, that where any of the grains or grasses are etiolated immediately after germination, by growing too rapidly, or by being sown too thick or in too warm a season, the first joint from which the coronal or nourishing roots spring is raised above the ground, and in consequence either throws out no roots at all, or so few as to nourish it imperfectly; in which case it either dies before it comes into flower, or before the seed is matured. (*Mem. de la Soc. Ag. de Seine*, tom. ii.)

4984. *Whether corn ought to be sown broadcast or in drills*, is a question which has given rise to considerable discussion. The cultivation in rows of such plants as admit of intertillage during the summer months, is known to supersede the use of a summer fallow on lighter soils. "In truth, the row culture of certain green crops is one of the greatest improvements of modern agriculture, and should be extended by every effort of instruction and example. By no other means yet known to us can so large a produce be raised from land under constant tillage, so beneficial a rotation of crops be adopted, or so great an economy be practised in the application of manures. But, while the advantages are thus apparent with regard to the application of this species of culture to our preparatory green crops, it does in no degree follow that advantages equally great will result from its application to our crops of white corn. The analogy, as it regards the nature of the plants which form the subject of cultivation, does not hold. The cereal grains send forth numerous shoots or suckers, and the goodness of the crop mainly depends on the vigour and number of the shoots which they send forth. The other kind of crops do not, generally speaking, tiller like wheat, barley, or oats, but rise from one stem. Reasoning from these principles, we should infer that the former class of plants should be cultivated in that manner in which they are best suited to summer tillage; that is, in rows: the latter in that manner in which the seed is most equally deposited in the upper stratum of the soil, which is in broadcast. The opinions, however, of intelligent agriculturists are not agreed as to the superiority in practice of the broadcast over the row system, even as it relates to the cereal grains. The farmer of Norfolk, or of the light soils of Sussex, will contend as strenuously for the superiority of the row system as the farmer of East Lothian for the broadcast system; and each may be right as it regards the application of the principle to the circumstances of his own situation. The question which is to be settled, however, is, — Which of the two systems

is to be regarded as the rule in husbandry, and which the exception? Now, — independently of the circumstances just adverted to, and judging only from the greater extent to which the broad-cast system is carried on in the country; from the fact of the row system having declined in favour in districts where it had once been most extensively practised; and from its having recently ceased to make progress in general practice, — we should be inclined to hold that, with respect to the cereal grains, the rule of agriculture is the broad-cast system, and the exception the row system. The cases falling under the exception may be, and doubtless are, very numerous and important. There are many light soils in which the seeds require to be deposited at a considerable and equal depth, and this the drill-machine effects better than sowing on the surface; and there are many thin cold clays which tend to throw out the plants, the best remedy for which is thought to be deep sowing.”

4985. *The sowing of corn from the hand*, “however, is known to be attended with some uncertainty; being dependent for the accuracy of the execution upon the skill and attention of the sowers. The regularity of the work is also affected by winds; and, unfortunately, the means rarely exist of detecting the degree of inaccuracy in the work until too late to correct it.” As a remedy for these inconveniences, we have already described a broad-cast hand drill (2576.), and shall here introduce a horse machine for the same purpose (*fig. 722 a. b.*), that has been for some years employed in “the agriculture of Northumberland, North Durham, and some of the southern counties of Scotland, for sowing broad-cast. As it regards economy alone, little perhaps is effected by the employment of this machine: its recommendations are the regularity and certainty with which it performs the work, and the rendering of the execution independent of unskilfulness or want of care in the operator.” (*Quar. Jour. Agr.* vol. ii. p. 250.)



“A man and a horse with this machine will sow between 25 and 30 acres in a day. The regular manner in which the seed is disseminated renders less seed necessary than in the common method of sowing by the hand. Besides the advantages arising from a saving of seed, the greater regularity, as it regards their distance from each other, with which the plants spring up, generally renders the crop superior to that sown in the other way. The machine has been described as adapted to the sowing of the common sorts of grain, but it is equally well calculated for sowing the cultivated grasses.” (*Quar. Jour. Agr.* vol. ii. p. 254.)

4986. *The preservation of corn* after it is threshed and cleaned is generally effected in granaries, where the grain is kept well ventilated by passing it frequently from one floor to another, or through winnowing machines.

4987. *It has been proposed and attempted* in France to preserve it in pits or dry cells at an equal temperature, and included from the atmosphere; but the experiments now going on for this purpose, more

especially by M. Ternaux at St. Ouen, near Paris, are not yet sufficiently matured to enable us to lay any useful result before the public. That corn has been so preserved in former ages, and that to a considerable extent, is beyond a doubt; and it is equally certain that in the interior of Africa, among the Caffres and other nations, as well as in the south of Russia, in Turkey, and in Egypt, the practice is still employed on a small scale. It may be doubted, we think, whether, with the present population of Europe, it could ever be generally adopted.

4988. *Preservation of corn in siloes.* Some account of the opening of a siloe was lately read to the Agricultural Society of Paris. "The place consisted of an icehouse, and the grain when put in was of the finest appearance, perfectly dried, and in excellent condition. The door had been hermetically sealed; and yet, when opened, a considerable thickness of the mass of corn was found destroyed by weevils, the latter being in such quantity as to occasion an elevated temperature. As part of the same corn had been perfectly well preserved in other siloes, the cause of this deterioration was sought for, and a hole was found in the lower part which had been made by mice, and which, by admitting air in sufficient quantity, had allowed the weevils originally in the corn to live, and increase their numbers to the degree mentioned. After some observations upon experiments which showed that insects could live for a very long time in vitiated air, a committee was named to ascertain the requisite state of the air, and the circumstances connected in the enquiry with the preservation of grain in these repositories. At another meeting of the society, M. Hachette described the method proposed by M. Clement to prevent the destruction of corn by weevils. It is founded upon a fact observed by him, that these insects cannot live in an atmosphere which contains less than a certain proportion of moisture. He therefore proposes that the corn should be subject to a continued ventilation of air dried by passing over quick-lime or chloride of calcium. All the weevils originally in the corn would thus be quickly destroyed." (*Recueil Industriel*, vol. xii. p. 208.)

4989. *The preservation of corn in the north of Russia* may deserve notice more as matter of curiosity, and for supplying ideas on the subject, than for imitation. The corn is dried in small ovens or chambers, which communicate with a larger chamber or oven by small tubes that enter the smaller chambers at the top. The oven is then filled with straw closely pressed, which is lighted and left to consume during the night. Next morning the corn is taken from the smaller chambers, the smoke from the ovens having passed into them and perfectly dried it. This practice has several advantages: the corn is lighter to move, and is kept much easier, without requiring to be constantly turned, being preserved from vermin by the smoky taste communicated to it by the straw, which does not quit it until it has passed through the mill. The corn intended to be kept for any length of time is put into pits, in shape like a bottle, sufficiently high for a man to stand erect in, which are dug in elevated places with a clayey soil. When they are dug a fire is lighted for four and twenty hours, which forms a hard crust round the pit. The interior is lined with the bark of the birch tree, fastened with wooden nails. Some straw is then put at the bottom, upon which the corn is placed, and more straw at the top, the mouth of the pit being then closed with a wisp of straw in the form of a cone. Each pit contains from twenty-five to one hundred tchetverts, and the grain in them will keep for twenty years without being injured. (*Biblioth. Univer. de Genève.*)

4990. *The uses to which the straw of corn may be applied* are various. Besides food for cattle, litter for animals, thatch, &c., it is bleached and plaited into ribands for forming hats, and bleached, dyed of different colours, split, and glued to flat surfaces, so as to form various works useful and ornamental. Paper is also made from straw; and the same pulp which forms the paper may be moulded into all the forms given to papier maché, medallion portraits, embossed works, &c. Whoever wishes to enter into the details of the great variety of articles that may be manufactured from straw, should consult the *Dictionnaire Technologique*, art. *Paille*; or an abridged translation of a part of the article in Gill's *Technological Repository*, vol. vi. new series, p. 228.

4291. *The diseases peculiar to the cereal grasses* have been included in the diseases common to vegetables in general. (1671.) They are chiefly the smut, the rust, the mildew, and the ergot; and we shall notice them more at length under the different species of corn which are most subject to suffer from them.

4992. *The practice of reaping corn before it is perfectly ripe* originated in France, and has lately been recommended by M. Cadet de Vaux.

4993. *Corn reaped eight days before the usual time*, this author says, has the grain fuller, larger, finer, and better calculated to resist the attacks of the weevil. An equal quantity of the corn thus reaped, with corn reaped at the period of maturity, gave more bread, and of a better quality. The proper time for reaping is that when the grain, on being pressed between the fingers, has a doughy appearance like the crumb of bread just hot from the oven, when pressed in the same manner. This does not seem to agree altogether with the experience of some agriculturists in the Carse of Gowrie, Perthshire, where oats intended to be made into meal are always found to yield most when allowed to stand as long as possible. Corn for seed, however, it is acknowledged by the same agriculturists, will answer the purpose perfectly though cut before fully matured. (*Perth Miscellany*, vol. i. p. 41.) If the doctrine of Cadet de Vaux be confined to wheat, it may be perhaps considered as confirmed by the following passage from Waistell:—"It is well known," he observes, "that wheat produces the most flour and the sweetest bread when threshed out before it has been stacked; and as all corn is more or less injured in both these respects, accordingly as it is more or less heated in the rick, it would be highly desirable totally to prevent its heating or becoming musty, in the ricks. In wet harvests it is sometimes impossible to get corn sufficiently dried; and we see that even in hot and dry harvests, such as that of 1819, a great deal of corn is sometimes spoiled in the ricks: we should, therefore, be extremely cautious to have corn well dried in the field, the ricks made of a moderate size, and raised off the ground, to admit the air to circulate under them, with chimneys to allow a current of air to pass upwards through them, to carry off the hot and musty air from the centre of the rick, which, without such a chimney, has its tendency to heat four-fold greater than one with a chimney. Chimneys being easily made, and so beneficial, it were to be wished that they were in general use." (*Waistell's Designs for Agr. Buildings*, p. 101.)

4994. *For seed corn*, it not only appears that unripe grain is preferable, but even that mildewed wheat and oats answer perfectly. Mr. S. Taylor, the editor of the *Country Times*, and formerly an extensive farmer, has been in the practice of sowing from 100 to 130 acres of wheat annually for 20 years and upwards. "The seed was invariably chosen, not from the best and plumpest, but the thinnest and most mildewed seed." He has seen the most beautiful samples of wheat produced from seed of the most ordinary description. (*Country Times*, March 22. 1830.) In Perthshire, the same is stated with respect to oats. (*Perth Miscellany*, vol. i. p. 41.)

4995. *The methods of reaping corn* are various. The most general mode is by the sickle, already described (2482. and 2483.); the scythe is also used, more especially for barley and oats; and a reaping machine (2737.) is beginning to be used in some parts of Scotland; in which country an effectual bean-reaping machine (2740.) was

in use many years ago. A method of mowing corn much practised in the county of Durham, and possibly Yorkshire, has lately been introduced into Northumberland, but does not appear to make much progress, the low priced Irish reapers doing the work so much more neatly and with less waste, though it costs more money to the owner. The scythe has a cradle similar to that described (405.); it is handled and used differently from the bow and grass scythes, and has only one short handle or "nib" on the "sned," or long handle, for the right hand; the left grasps the "sned" with the palm upwards: this enables the mower, who generally mows "from the corn," to bring the back of the scythe and cradle to the ground, and leave the cut corn in a beautiful state for being put into sheaves. A good workman can do two, and some three acres a day: they charge about 5s. per acre for mowing, binding, and stooking (shocking): this practice may be advantageously followed wherever the crop is not stricken down by rains, particularly barley crops. (*C. near Alnwick, in Gard. Mag. vol. vi.*)

4996. *Frosted corn*, like frosted seeds of any sort, may be detected by dissection and comparison with unfrosted corn. By frosted corn is to be understood corn that has been frozen on the plant before it was perfectly ripe, in consequence of which the germ of the future plant or vital part of the seed is deprived of its vitality by the expansion produced by the freezing of its watery parts.

4997. *Frosted oats*. The oat being one of the latest corns, and a corn of cold rather than of warm countries, is more liable to be frozen than any other; but fortunately, also, frozen oats are more easily detected than either frozen wheat or barley. The Rev. James Farquharson, who has paid much attention to this subject, and written an elaborate article on it in the *Farmer's Magazine* (vol. xix.), observes, that every kernel, when stripped of the husk, will be found to exhibit the appearance of a groove on one side. If the bottom of the groove has a smooth clear translucent appearance from end to end; if it is not much shrunk into the substance of the kernel; and if the kernel splits with difficulty in its direction, then we may pronounce the vital part of the seed to be free from injury by frost. If, on the contrary, there is a black speck seen in the groove at the root end of the kernel; if the groove cuts deep into the kernel, so that it may be split in that direction; and if, when the kernel is so split, the blackness, accompanied with a rotten scaly appearance, is seen extending from end to end at the bottom of the groove, then the vital part or future plant may be pronounced entirely unfit for being used as seed.

4998. *Frosted barley*. The nature of the injury that ripening barley suffers from frost is similar to that suffered by oats. The husk of barley, like that of oats, consists of two unequal parts; the small part covering the groove of the kernel. In sound grain, when dry, the hull is firmly attached to the kernel; but in frosted grain the small part of the hull becomes loose, and feels soft on being pressed; and if, in such grain, this part of the hull is stripped away, a blackness and rottenness, resembling that in frosted oats, will be seen in the bottom of the groove. In frosted barley the husk becomes loose all round the root end; but, as this is a circumstance that is occasionally observed likewise in barley that was never exposed to frost, it certainly sometimes arises from other causes, — perhaps from wet; and this, unless the grain has germinated, does not render it unfit for seed or malting. The only sure mark of damage from frost is the blackness and rottenness in the bottom of the groove.

4999. *Frosted wheat*. Upon an attentive inspection of wheat that has been exposed to the frost, it will be observed that in a large proportion of grains there is a rotten scaly appearance where the embryo of the plant is attached to the cotyledon or mealy part of the grain; that the groove is much deeper than in wheat that was saved before the frost; and that the grains are easily split in its direction. From this it is inferred that wheat, in its ripening stage, suffers from frost an injury of the same nature with that sustained by oats and barley. (*Farm. Mag. vol. xix.*)

5000. *The nutritive products* of the plants to be treated of in this section, are thus given by Sir H. Davy.

Systematic Names.	English Names. The quantity analysed, of each sort 1000 parts.	Whole quantity of soluble or nutritive matter.	Mucilage or starch.	Saccharine matter or sugar.	Gluten or albumen.	Extract, or matter rendered insoluble during the operation.
<i>Triticum hybérnum æstivum</i>	Middlesex wheat, average crop -	955	765	—	190	
	Spring wheat - - -	940	700	—	240	
	Mildewed wheat of 1806 - - -	210	178	—	32	
	Blighted wheat of 1804 - - -	650	520	—	130	
	Thick-skinned Sicilian wheat of 1810	955	725	—	230	
	Thin-skinned Sicilian wheat of 1810	961	722	—	239	
	Wheat from Poland - - -	950	750	—	200	
	North American wheat - - -	955	730	—	225	
<i>Hórdeum vulgàre</i> <i>Avèna sativa</i> <i>Secàle cereàle</i>	Norfolk barley - - -	920	790	70	60	
	Oats from Scotland - - -	743	641	15	87	
	Rye from Yorkshire - - -	792	645	38	109	

SECT. I. *Wheat*. — *Triticum* L.; *Triándria Digynia* L., and *Gramíneæ* J. *Froment*, Fr.; *Weitzen*, Ger.; *Grano*, Ital.; and *Trigo*, Span.

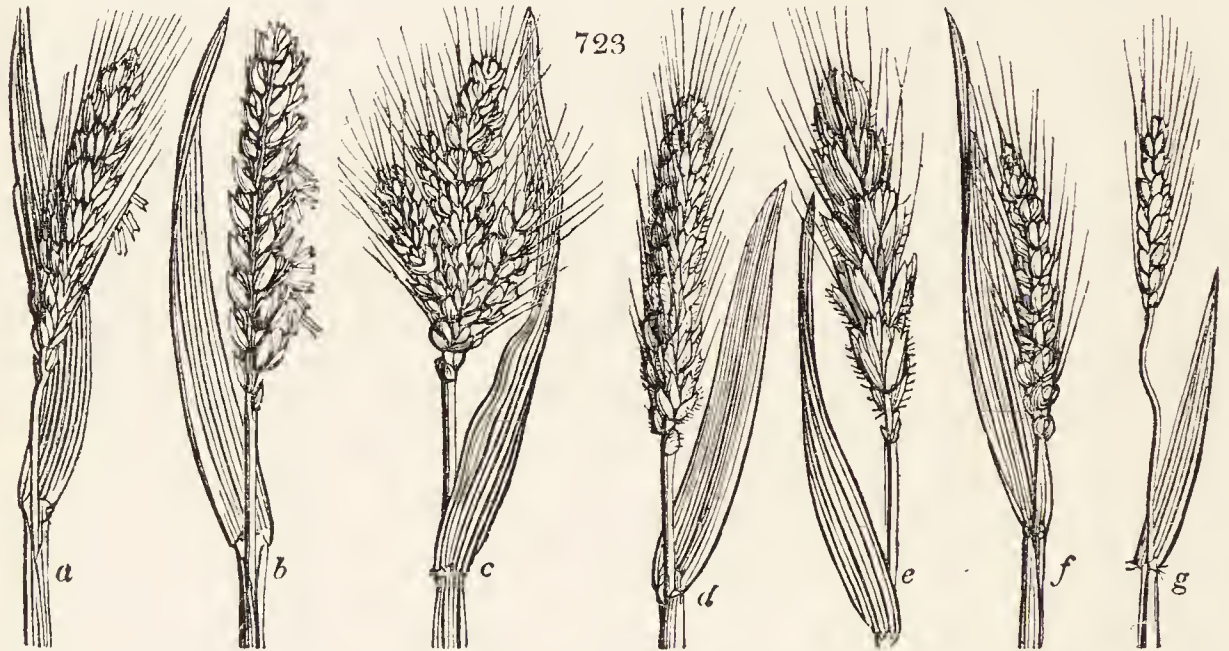
5001. *Wheat is by far the most important of the cereal grasses*, the flour made from its grains or seeds, from the quantity of gluten they contain, making the best bread in the world. A greater proportion of mankind are nourished by rice than by wheat, but there is no grain which comes near wheat in its qualities for bread-making. Rice and maize are comparatively unfit for it, and oats, barley, and rye but imperfectly adapted. Rye, however, comes nearer to wheat in its bread-making qualities than any other grain.

5002. *Of what country wheat is a native*, is totally unknown; it has been supposed indigenous to Asia and Africa, and unquestionably it is more likely to belong to these

parts of the world than any other ; but all that can be advanced on this subject is conjecture. Wheat, with the exception it is said of some parts of the southern coast of Africa, is cultivated in every part of the temperate and torrid zones, and in some places as high as 2000 feet above the level of the sea. It has been grown from time immemorial in Britain, but in few places at a greater elevation than 600 feet. Of course the elevation to which any plant can be cultivated always depends on the latitude of the situation.

5003. *Species and varieties.* (fig. 723.) Botanists reckon seven species of *Triticum*, which are or may be cultivated for their grains, besides many varieties and subvarieties of those in common culture. The species or subspecies are,

- | | |
|---|--|
| 1. <i>Triticum aestivum</i> , Summer wheat or spring wheat (a). | 5. <i>Triticum polonicum</i> , Polish wheat (e). |
| 2. <i>hybérnum</i> , Lammas wheat (b). | 6. <i>Spélta</i> , Spelt wheat (f). |
| 3. <i>compositum</i> , Egyptian wheat (c). | 7. <i>monocóccum</i> , One-grained wheat (g). |
| 4. <i>túrgidum</i> , Turgid wheat (d). | |



The first, second, fourth, and fifth sorts are by many botanists considered as only varieties, and it is doubtful whether the third and sixth may not be the same ; the seventh has all the marks of a distinct species, but it is very questionable whether, if much cultivated, it would always continue to produce one row of grains.

5004. *The spring or summer wheat (a), Blè de Mars, Fr.*, is distinguished from that generally sown, by its narrower ears, longer beards, smaller grains, and shorter and more slender straw, and also by its inability to endure our winters. It is commonly sown in April, or even so late as May. It was known to Parkinson in 1666, but has never been much cultivated, except in Lincolnshire. It was tried and given up in Northumberland and Mid Lothian, and also in some counties near London. Many varieties of summer wheat were transmitted a few years ago to the president of the Board of Agriculture from the Agricultural Society of Paris, for the purpose of experiment, and were divided among several distinguished agriculturists, (*Comm. to the Board of Agr.*, vol. vii. p. 11.) ; but there has not yet been time for establishing their comparative merits, or their adaptation to the climate of Britain. Summer, or, as it is often called, spring, wheat has however been long and extensively cultivated in some parts of England, particularly in Lincolnshire ; and it is probable may be found a valuable crop in the southern counties ; but the trials that have been made in the north, do not seem to entitle it to a preference over winter wheat sown in spring, or even oats or barley, in that climate.

5005. *Of the winter or common wheat (b), Froment blanc, Fr.*, there are a great number of varieties. Professor Martyn, in Miller's *Dictionary*, has described forty-nine sorts, and Professor Thaer speaks of a hundred, but affirms that those who describe them know nothing about them, and in all probability include one sort under different names. All the varieties may be reduced to two, the white, and the brown or red grained. As subvarieties, there are the bearded and beardless, the woolly-chaffed, and thin or hairy chaffed, both of the reds and whites. To these some add another variety, which is the spring-sowing common wheat. It is stated by those who maintain that this variety exists, that through long sowing the progeny, after a number of generations, acquires a habit of coming earlier into blossom than seed from winter-sown grain. This we think very likely, but are not aware that the variety is distinctly known by any recognisable marks in the plants. The red or brown wheats are universally considered more hardy than the white, but as yielding an inferior flour : the woolly-white is supposed to yield the best flour ; but woolly-chaffed wheats are considered more liable to the mildew than any other.

5006. *The Egyptian, or many-spiked wheat (c), Blè de miracle ou de Smyrne, Fr.*, the turgid grey pollard or duck-bill wheat (d), and the Polish wheat (e), may, for all agricultural purposes, be considered only varieties of the common winter wheat. They are cultivated in a few places in England, and seeds of them may be procured from the public botanic gardens ; but they are in little estimation.

5007. *Spelt wheat (f), the Epautre of the French*, is known by its stout straw, which is almost solid, and by its strong pikes, with chaff partially awned, the awns long and stiff. The chaff adheres so closely to the grain as not to be separated without great difficulty. This grain, as we have seen, is a good deal sown in the south of Europe. In France it is sown in spring, on land too coarse for common wheat, and it ripens in July and August. It is the principal wheat sown in Suabia and the north of Switzerland ; and is a good deal sown in Spain. The grain is light, and yields but little flour ; but it is said to contain a larger portion of gluten than common wheat, and for that reason is recommended as superior to any other in pastry and confectionary. It is not cultivated in Britain.

5008. *The one-grained wheat (g), Petit épautre, Fr.*, is known by its small thin spike, and single row of grains ; the leaves and straw are remarkably small, but very hard ; and the plants tiller very much. It is chiefly cultivated in the mountainous parts of Switzerland, where its straw, like that of the former species, is much used for thatching. The grain makes a brown light bread ; but its great excellence, according to Villars, is for grucl.

5009. *To procure new varieties of wheats*, the ordinary mode is to select from a field a spike or spikes from the same stalk, which has the qualities sought for; such as larger grains, thinner chaff, stiffer straw, a tendency to earliness or lateness, &c.; and picking out the best grains from this ear or ears, to sow them in suitable soil in an open airy part of a garden. When the produce is ripe, select the best ears, and from these the best grains, and sow these, and so on till a bushel or more is obtained, which may then be sown in a field apart from any other wheat. In this way, many of the varieties of our common winter wheat have been obtained; as the hedge-wheat which was reared from the produce of a stalk found growing in a hedge in Sussex, by one Wood, about 1790. Other varieties have assumed their distinctive marks from having been long cultivated on the same soil and climate, and take local names, as the Hertfordshire red, Essex white, &c.

5010. *Marshall*, (Yorkshire) mentions a case in which a man of accurate observation, having in a piece of wheat perceived a plant of uncommon strength and luxuriance, diffusing its branches on every side, and setting its closely-surrounding neighbours at defiance, marked it; and at harvest removed it separately. The produce was 15 ears, yielding 604 grains of a strong-bodied liver-coloured wheat, differing, in general appearance, from every other variety he had seen. The chaff was smooth, without awns, and of the colour of the grain; the straws stout and reedy. These 604 grains were planted singly, nine inches asunder, filling about 40 square yards of ground, on a clover stubble, the remainder of the ground being sown with wheat in the ordinary way; by which means extraordinary trouble and destruction by birds were avoided. The produce was two gallons and a half, weighing 20½ lbs. of prime grain for seed, besides some pounds for seconds. One grain produced 35 ears, yielding 1235 grains; so that the second year's produce was sufficient to plant an acre of ground. What deters farmers from improvements of this nature is probably the mischievousness of birds; from which at harvest it is scarcely possible to preserve a small patch of corn, especially in a garden or other ground situated near a habitation; but by carrying on the improvement in a field of corn of the same nature, that inconvenience is got rid of. In this situation, however, the botanist will be apprehensive of danger from the floral farina of the surrounding crop. But from what observations *Marshall* has made he is of opinion his fears will be groundless. No evil of this kind occurred, though the cultivation of the above variety was carried on among *white* wheat.

5011. *But the most systematic mode of procuring new varieties*, is by crossing two sorts, as in breeding; that is, by impregnating the female organs of the blossoms of one ear with the fecundating matter or pollen of the male organs of the blossom of another variety of a different quality. Thus, supposing a farmer was in the habit of cultivating a very good variety, which he wished to render somewhat earlier, let him procure in the blossoming season, from a very early soil, some spikes of an early sort just coming into blossom; and let him put the ends of these in water, and set them in the shade so as to retard their fully blossoming till the plants he has destined to become the females come into flower. Then let him cut out all the male organs of the latter, before they have advanced so far as to impregnate the stigma; and, having done this, let him dust the stigma with the blossoming ears of the early or male parent. The impregnated stalks must then be kept apart from other wheats that the progeny may be true. When the grains ripen, let him sow the best; and from the produce, when ripe, select the earliest and finest spikes for seed. Let him sow these, and repeat the choice till he procures a bushel or two of seed. This operation has been successfully performed by *T. A. Knight* (1633); and though it may be reckoned too delicate for farmers in general, it will be looked on by the philosophical agriculturist as not improbably leading to results as important as those which have attended the practice in the case of garden fruits and flowers. The scientific farmer may consult on this subject *Bishop's Causal Botany* already referred to, the *Gardener's Magazine*, and *Saggio Botanico Georgico intorno l'ibridismo delle Piante*, by *Billardi*. Pavia, 1809.

5012. *The propagation of wheat by transplanting* may be employed to expedite the progress of cultivating a new variety of ascertained excellence. To show what may be gained in time by this mode, we shall quote from *The Philosophical Transactions* an account of an experiment made by *C. Miller*, son of the celebrated gardener of that name, in 1766. On the 2d of June, *Miller* sowed some grains of the common red wheat; and on the 8th of August, a single plant was taken up and separated into 18 parts, and each part planted separately. These plants having pushed out several side shoots, by about the middle of September, some of them were then taken up and divided, and the rest of them between that time and the middle of October. This second division produced 67 plants. These plants remained through the winter, and another division of them, made about the middle of March and the 12th of April, produced 500 plants. They were then divided no further, but permitted to remain. The plants were, in general, stronger than any of the wheat in the fields. Some of them produced upwards of 100 ears from a single root. Many of the ears measured seven inches in length, and contained between 60 and 70 grains. The whole number of ears which, by the process above mentioned, were produced from one grain of wheat, was 21,109, which yielded three pecks and three quarters of clean corn, the weight of which was 47 lbs. 7 ounces; and, from a calculation made by counting the number of grains in an ounce, the whole number of grains was about 386,840. By this account we find, that there was only one general division of the plants made in the spring. Had a second been made, *Miller* thinks the number of plants would have amounted to 2000 instead of 500, and the produce thereby much enlarged.

5013. *In making a choice from all the species and varieties* which we have named, the thin-skinned white wheats are preferred by all the best British farmers whose soil and climate are suitable for this grain, and for sowing in autumn. In late situations, and less favourable soils and climates, the red varieties are generally made choice of; and these are also generally preferred for sowing in spring. Red wheats, however, are considered as at least fifteen per cent. less valuable than the white varieties. No subvariety ever continues very long in vogue; nor is it fitting that it should, as degeneracy soon takes place, and another and better is sought for as a successor. Hence the only recommendation we can give, as to the choice of subvarieties, is, to select the best from among those in use by the best farmers in the given situation, or nearest well-cultivated district.

5014. *The soils best adapted for the culture of wheat*, are rich clays and heavy loams; but these are not by any means the only description of soils on which it is cultivated. Before the introduction of turnips and clover, all soils but little cohesive were thought unfit for wheat; but, even on sandy soils, it is now grown extensively, and with much advantage, after either of these crops. The greater part of the wheat crop throughout

Britain, however, is probably still sown upon fallowed land. When it succeeds turnips consumed on the ground, or clover cut for hay or soiling, it is commonly sown after one ploughing. In Scotland, when wheat is to be sown after clover upon heavier soils, or after grass of two or more years, the land is ploughed twice or thrice, or receives what is called a rag fallow. In Norfolk and Suffolk, wheat is seldom sown after fallow or turnips; but the farmer there thinks himself almost sure of a good wheat crop after a good clover crop. One ploughing only is required, and the seed is dibbled in the flag, as they call it; that is, on the turned-over surface or furrow slice.

5015. *On rich clays*, wheat may be cultivated almost every second year, provided due care is taken to keep the land clean, and in good condition. A summer fallow once in four, six, or eight years, according to seasons and circumstances, is, however, necessary; and manure should either be applied on that fallow for the first crop of wheat, or, what some people think preferable, should be laid on the wheat-stubble for a crop of drilled beans, which ensures the succeeding crop of wheat. If the first crop of beans has been completely cleaned, there is no difficulty in repeating, and even in extending the course; and the crops will be little inferior to those gained at the beginning of the rotation, provided manure has been bestowed to each crop of beans. In this way, when the ground is fallowed every fourth year, two crops of wheat and one of beans are gained from manuring once; when fallowed every sixth year, three crops of wheat and two of beans are gained from manuring twice; and, when fallowed every eighth year, four crops of wheat and three of beans from manuring thrice. In the first-mentioned shift, less manure is bestowed than in either of the others; and, if the soil is of good quality, it will support itself: whereas, in the shifts of six and eight, unless foreign manure be procured, it rarely happens that they can go on successfully for any length of time, without abstracting dung from other parts of the farm on which they are practised. (*Brown's Tr. on Rural Affairs.*)

5016. *In cultivating wheat on thin clays*, the rotations just mentioned are inapplicable. A six-course shift of a different kind has, however, been successfully followed by many people; but it requires every branch of the work to be well executed. 1st, a summer fallow, dunged at the rate of twelve or fourteen double loads per acre; 2d, wheat; 3d, grass; 4th, oats; 5th, peas and beans drilled; 6th, wheat. If manure can be given in the middle of the shift, every one of the crops may be expected good; but if that is withheld, there will necessarily be a proportionable falling off in the two last crops. Husbandmen must, however, regulate their practice according to their means, though it deserves to be remarked, that, if greater attention were paid to the collecting of materials which ultimately are converted into manure, many deficiencies in the article would be fully supplied. (*Brown.*)

5017. *Excellent wheat may be grown on light soils*, with the exception of soft sands. Such soils, however, are not constitutionally disposed to the growth of that grain; nor will they, under any management, bear such a frequent repetition of it as those already mentioned. Summer fallow on them may safely be dispensed with; because a crop of turnips, which admits every branch of the cleaning process to be more perfectly executed than even a naked or bare fallow does, may be profitably substituted. Wheat here comes in with propriety after turnips, though, in general cases, it must be sown in the spring months, unless the turnips are stored; in which case it may be sown in November, or it may be sown after clover, for the fourth crop of the rotation; or in the sixth year, as a way-going crop, after drilled peas and beans, if the rotation is extended to that length. But, take it any way, it is scarcely possible to raise wheat as extensively upon light soils, even where they are of the richest quality, as is practicable upon clays; nor will a crop of equal bulk upon the one, return so much produce in grain as may be got from the other. To enlarge upon this point would only serve to prove what few husbandmen will dispute, though it may be added, that, on thin sands, wheat ought not to be ventured, unless they are either completely clayed or marled; as it is only with the help of these auxiliaries that such a soil can gain stamina capable of producing wheat with any degree of success. (*Brown.*)

5018. *The culture of the soil intended for wheat varies according to its nature, and the preceding and following crops.*

5019. *On soils really calculated for wheat*, though in different degrees, summer fallow is the first and leading step to gain a good crop or crops of that grain. The first furrow should be given before winter, or so early as other operations upon the farm will admit; and every attention should be used to go in as deep as possible; for it rarely happens that any of the succeeding furrows exceed the first one in that respect. The number of after-ploughings must be regulated by the condition of the ground and the state of the weather; but, in general, it may be observed, that ploughing in length and across, alternately, is the way by which the ground will be most completely cut, and the intention of fallowing accomplished. It has been argued, that harrowing clay soils, when summer-fallowed, is prejudicial to the wheat crop; but without discussing this point (such a discussion being unnecessary), it may merely be stated, that, in a dry season, it is almost impracticable to reduce real clays, or to work them too small; and that, even in a wet one, supposing they are made surface-smooth, they will, when ploughed up again, consolidate into clods or big lumps after forty-eight hours' drought, and become nearly as obdurate as ever. It is only on thin soils, which have a mixture of peat earth, and are incumbent on a bottom impervious to water, that damage is at any time sustained by over-harrowing. Such are generally of a weak texture, and may be broken down with facility by the roller and harrow. If caught by much rain before the pores are in some measure closed, the moisture is greedily absorbed; and being prevented from going downwards by the hardness of the subsoil, the whole surface becomes a kind of mortar or paste, unless previously well ridged up; which, to a certain extent, prevents the consequences from being dangerous. These evils, however, must be submitted to by the possessors of such soils, if they want to have them sufficiently fallowed and prepared in a proper manner; for, without reducing them, couch-grass, and especially moss, with which they are commonly stored, cannot be eradicated. If they are reduced in the early part of the season, the danger is small; but to break them down in the latter part ought always to be avoided, unless called for by imperious necessity.

5020. *When wheat is sown after beans* it rarely happens, in this northern climate, that more than one ploughing can be successfully bestowed. Before this is given, it is advantageous to cross-harrow the land, which levels the drills, and permits the ploughing process to be executed with precision. Almost in every case the ridges should be gathered up, so that the furrows may be well cleared out, and the plants preserved from injury during the inclement winter season. Clover land should be neatly ploughed, and well laid over, so that the roots of the grasses may be buried and destroyed; for it frequently happens that crops of wheat, after clover and rye-grass, are greatly injured by inattention to the ploughing process. In short, sowing wheat after clover on clayey soils in Scotland may be considered as the most hazardous way in which that grain can be cultivated. (*Brown's Tr. on Rural Affairs.*)

5021. *The manures best calculated for wheat*, are allowed by all agricultural chemists to be animal matters and lime. The former has a direct influence in supplying that essential constituent to wheaten flour, gluten; and the latter azote and lime, both actually found in the straw of wheat. At all events, it is certain that wheat will not

thrive on any soil which does not contain lime. In this Sir H. Davy, Chaptal, Professor Thaer, and Grisenthwaite fully agree.

5022. *A more abundant supply of manure* is generally required for wheat than for any other grain. Professor Thaer says it absorbs more nourishment from the soil than any of the corn tribe; and he calculates (hypothetically, as he allows,) that for every 100 parts of nutriment in a soil sown with this grain, 40 will be carried off by the crop. (*Principes Raisonnés*, tom. iv. art. *Froment*.) At the same time, too large a dose of manure on land in good tilth is very apt to cause the crop to lodge; and hence some people think it improper to dung rich clays or loams when fallowed, and choose rather to reserve that restorative till the succeeding season, when they are prepared for a crop of drilled beans. Delaying the manuring process for a year is attended with many advantages; because good land, fully wrought, contains such a principle of action within itself, as often causes the first wheat crop to be lodged before it is filled; under which circumstance, the produce is diminished both in quantity and quality. The delay in manuring is, however, attended with disadvantages; because, when dung is kept back till the end of autumn or beginning of winter, to be laid on the stubbles, the weather is often so wet that it cannot be carted on without subjecting the land to injury from poaching, whilst the labour in laying it on is also increased. On thin elays, or even upon soils of the other description not in high condition, there can be no doubt but that the end of summer, and upon summer fallow, is the most proper time for manuring, though it will be found, that an improvident expenditure of dung on such occasions ought always to be steadily avoided. (*Brown*.)

5023. *Where manure is abundant*, it is stated by some that wheat alternating with a green crop, or indeed any corn crop and a green crop, may be grown alternately for an indefinite time. (*Farm. Mag.* vol. xxiii. p. 298.) It is alleged by others, that this doctrine is not supported by experience. Constant tillage, they say, wears out the best soils, and the grain degenerates in quality, if not in quantity too. Instances, however, are given in *The Communications to the Board of Agriculture* of potatoes and wheat having been grown alternately on the same soil for a number of years, and very good crops produced. It may be useful to know that the thing is not impossible.

5024. *The climate* required to bring wheat to perfection must be such as affords a dry and warm season for the blossoming of the ear, and the ripening of the grain. Wheat will endure a great deal of cold during winter, if sown in a dry or well drained soil; and if it be covered with snow. Hence it is that wheat is sown as far north as Petersburg and in Sweden. Moderately moist weather before the flowering season, and after the grain is set or formed, is favourable to wheat; but continued heavy rains after the flowering season produce the smut. The dry frosty winds of February and March, and even of April in some districts, are more injurious to the wheats of Britain than any other description of weather. Hoar frosts, when the plant is in the ear, produce blights; and mildews often result from or follow sultry winds and fogs. Cold, in the blossoming and ripening season in July, even unaccompanied by wind or rain, produces an inferior grain, greatly deficient in gluten; and neat the contrary. The most valuable wheat of Europe, in this respect, is that of Sicily; which Sir H. Davy found to contain much more gluten than the best wheat of Britain.

5025. *The season for sowing wheat on clays* is generally the latter end of autumn; on early turnip soils it is sown after clover or turnips, at almost every period from the beginning of September till the middle of March; but the far greater part is sown in September and October. For summer wheat, in the southern districts, May is sufficiently early, but in the north, the last fortnight of April is thought a more eligible seed-time. In the cultivation of spring-sown winter wheat, it is of importance to use the produce of spring-sown grain as seed, as the crop of such grain ripens about a fortnight earlier than when the produce of the same wheat winter-sown is employed as spring seed. (*Encyc. Brit.* art. *Agr.*)

5026. *Seed wheat is prepared for sowing by the process called pickling*. According to Brown (*Treatise on Rural Affairs*, art. *Wheat*), this process is indispensably necessary on every soil; otherwise smut, to a greater or less extent, will, in nine cases out of ten, assuredly follow.

5027. *Though almost all practical farmers are agreed as to the necessity of pickling*, yet they are not so unanimous as to the *modus operandi* of the process, and the article which is best calculated to answer the intended purpose. Stale urine may be considered the safest and surest pickle; and where it can be obtained in a sufficient quantity, it is commonly resorted to. The mode of using it does not, however, seem to be agreed upon; for, while one party contends that the grain ought to be steeped in the urine, another party considers it sufficient to sprinkle the urine upon it. Some, again, are advocates for thoroughly steeping the grain in a pickle made of salt and water, sufficiently strong to buoy up a fresh egg. But whatever difference of opinion there may be as to the kind of pickle that ought to be used, and the mode of using it, all admit the utility of mixing the wetted seed with hot lime, fresh slaked; and this, in one point of view, is absolutely necessary, so that the seed may be equally distributed. It may be remarked, that experience justifies the utility of all these modes, provided they are attentively carried into execution. There is some danger from the first; for if the seed steeped in urine is not immediately sown, it will infallibly lose its vegetative power. The second, viz. sprinkling the urine on the seed, seems to be the safest, if performed by an attentive hand; whilst the last may do equally well, if such a quantity of salt be incorporated with the water as to render it of sufficient strength. It may also be remarked, that this last mode is oftener accompanied with smut, owing no doubt to a deficiency of strength in the pickle; whereas a single head with smut is rarely discovered when urine has been used.

5028. *An improved mode of preparing wheat for sowing* has recently been adopted in the south of Scotland, and followed with great success. It is thus described:—"Take four vessels, two of them smaller than the other two, the former with wire bottoms, and of a size to contain about a bushel of wheat, the latter large enough to hold the smaller within them. Fill one of the large tubs with water, and putting the wheat in the small one, immerse it in the water, and stir and skim off the grains that float above, and renew the water as often as is necessary, till it comes off almost quite clean. Then raise the small vessel in which the wheat is contained, and repeat the process with it in the other large tub, which is to be filled with stale urine; and in the mean time wash more wheat in the water tub. When abundance of water is at hand, this operation is by no means tedious; and the wheat is much more effectually cleansed from all impurities, and freed more completely from weak and unhealthy grains and seeds of weeds, than can be

done by the winnowing machine. When thoroughly washed and skimmed, let it drain a little, then empty it on a clean floor or in the cart that is to take it to the field, and sift quick-lime upon it, turning it over and mixing it with a shovel till it be sufficiently dry for sowing." (*Supp. E. Brit. art. Agr.*)

5029. *The quantity of seed* necessarily depends both on the time of sowing and the state of the land; land sown early requiring less than the same land when sown in winter or spring; and poor land being at all times allowed more seed than rich. The quantity accordingly varies from two bushels, or less, to three, and sometimes even to four, bushels per English statute acre. Winter wheat, when sown in spring, ought always to have a liberal allowance, as the plants have not time to tiller much without unduly retarding their maturation. (*Supp. &c.*) Upon well prepared lands, if the seed is distributed equally, it can scarcely be sown too thin; perhaps two bushels per acre are sufficient; for the heaviest crops at autumn are rarely those which show the most vigorous appearance through the winter months. Bean stubbles require more seed than summer fallows; because the roughness of their surface prevents such an equal distribution; and clover layers ought to be still thicker sown than bean stubbles. Thin sowing in spring ought not to be practised, otherwise the crop will be late, and imperfectly ripened. (*Brown.*)

5030. *The modes of sowing wheat* are either broad-cast, drilling, ribbing, or dibbling. The first mode is by far the most general, more especially in the north of England and Scotland, and the seed is for the most part covered by the harrows. No more harrowing, Brown observes, should be given to fields that have been fallowed than what is necessary to cover the seed, and level the surface sufficiently. Ground which is to lie in a broken-down state through the winter, suffers severely when an excessive harrowing is given, especially if it is incumbent on a close bottom; though as to the quantity necessary none can give an opinion except those who are present.

5031. *Ploughing in.* Many farmers allege that wheat which is harrowed in is apt to be thrown out in spring; or if not thrown out at that season, that it does not tiller well, and that the stalks are apt to dwindle away and fall down in the flowering season. It is certain that this is the case in many parts of England; and the cause assigned by the northern farmers is the defective manner in which the land is ploughed, by which there is not sufficient covering for the seed. To guard against these evils it is a very general practice in most of the southern counties, when wheat is sown broad-cast, to plough it in with a shallow furrow. This is done even after beans and on clover leys, and is a favourite practice on very opposite soils, as in Norfolk and Middlesex.

5032. *Drilling*, however, is extensively practised in some districts, and is becoming more general on lands infested with the seeds of annual weeds, especially when sown in spring. A machine which sows at three different intervals, according to the judgment of the farmer, of twelve, ten and a half, or nine inches, is much approved of in the northern districts. It deposits six, seven, or eight rows at once, according to its adjustment to one or other of these intervals, and the work is done with ease and accuracy when the ridges are previously laid out of such a breadth (twelve feet and a half) as to be sown by one bout; the machine going along one side of such a ridge, and returning on the other, and its direction being guided by one of its wheels, which thus always runs in the open furrow between the ridges. If the ten and a half inch interval be adopted, and it is the most common one in that country, the machine sows seven rows at once, or fourteen rows on a ridge of twelve feet and a half. But the space between the rows varies in some parts still more than this machine admits of; it ought not, however, to be so narrow as to prevent hand-hoeing, even after the crop has made considerable progress in growth; and it cannot advantageously be so wide as to admit the use of any effective horse-hoe.

5033. *Ribbing is a mode of sowing common in some places*, by which a drill machine is dispensed with, though the same purpose is nearly answered. This we have already adverted to in the section on tillage. The seed is scattered with the hand in the usual broad-cast manner, but as it necessarily falls for the most part in the furrows between the ribs, the crop rises in straight parallel rows, as if it had been sown by a drill machine; after sowing, the ribs are levelled by harrowing across them. This plan has nearly all the advantages of drilling in, as far as it regards exposure to the rays of the sun, and the circulation of air among the plants; but as some plants must always rise between the rows, it is not quite so proper when hoeing is required. (*Sup. E. Brit.*)

5034. *The dibbling of wheat* is practised in some parts of Norfolk. The furrow is laid over flat, and a row of holes is made along the middle of each by a man who uses a dibber in each hand. A middling workman will make four holes in a second. One dibbler is sufficient for three droppers; whence one man and three children are called a *set*. The dibbler carries on three flags or turned furrows; going on some yards upon one of the outside furrows, and returning upon the other, after which he takes the middle one; and thus keeps his three droppers constantly employed; and at the same time is in no danger of filling up the holes with his feet. The droppers put two or three grains of wheat into each hole; but much time and patience is necessary to teach them to perform the business properly and quickly. An expert dibbler will hole half an acre in a day; though one third of an acre is usually reckoned a good day's work. The seed is covered by means of a bush harrow; and from one bushel to six pecks is the usual quantity for an acre. Notwithstanding the advantages of saving seed, as well as some others which are generally reckoned undeniable, it is asserted by some very judicious farmers, that dibbling of wheat on the whole is not really a profitable practice. It is particularly said to be productive of weeds, unless dibbled very thick: which, indeed, may probably be the case, as the weeds are thus allowed a greater space to vegetate in. Marshall is of opinion, that the dibbling of wheat appears to be peculiarly adapted to deep rich soils, on which three or four pecks dibbled early may spread sufficiently for a full crop; whereas light, weak, shallow soils, which have lain two or three years, and have become grassy, require an additional quantity of seed, and consequently an addition of labour, otherwise the plants are not able to reach each other, and the grasses of course find their way up between them, by which means the crop is injured, and the soil rendered foul. It is alleged, that if a single grain of good size and sound could be dropped in each hole and no more, there might be an advantage in dibbling, where it could be accomplished at a moderate rate; but where two or three grains are put in each hole, and often six or eight, the source of profit is diminished or destroyed by twofold means; first, by using too much seed; and secondly, because three or four grains springing out of one hole will not make such a strong plant or stool as one sound grain. In answer to these remarks, we are informed, that an inquisitive farmer himself dibbled a great many holes, and dropped carefully one, two, three, &c. to ten grains of wheat in each hole. He carefully gathered the wheat, and put the produce of all the one grain holes, and of the two grain holes, and of the three, and so on to the ten, apart: on cleaning the ten portions, those holes which had three, four, and five grains were decidedly the heaviest produce; and he reasonably concluded that three, four, and five grains were the properest number to drop into each hole. To attempt dibbling either wheat or beans by hand on a large scale, we

consider quite unsuitable to the present improved state of agriculture ; but it may sometimes happen, that on rich loamy land, especially in a showery season, there may be no other way of getting in the seed.

5035. *The after-culture of wheat, or culture of the growing crop, depends on the manner in which it has been sown.*

5036. *When wheat is sown broad-cast, the subsequent culture must generally be confined to harrowing, rolling, hand-weeding, or hand-hoeing with a pronged hoe. As grass seeds are frequently sown in spring on winter-sown wheat, the harrows and roller are employed to loosen the soil, and cover the seeds. But these operations, to a certain extent, and at the proper season, are found beneficial to the wheat crop itself, and are sometimes performed even when grass seeds are not to be sown. One or two courses of harrowing penetrate the crust which is formed on tenacious soils, and operate like hand-hoeing in raising a fresh mould to the stems of the young plants. Rolling in spring ought never to be omitted on dry porous soils, which are frequently left in so loose a state by the winter frosts, that the roots quit the soil and perish ; and, if the land is rough and cloddy, the roller has a still more beneficial effect than the harrows in pulverising the inert masses, and extending the pasture of the plants. Hand-weeding, so far as to cut down thistles and other long weeds, is never neglected by careful farmers ; but the previous culture ought to leave as little as possible of this work to be done when the crop is growing. (Supp.)*

5037. *When wheat has been drilled, ribbed, or dibbled, the intervals may be hoed or stirred either by hand-hoes, common or pronged, or by horse-hoes or drill harrows. In general, the drill used at sowing will, by the changes it admits of in its double character of drill and horse-hoe, be the best to use for hoeing or stirring ; or if a single drill should have been used, the expanding horse-hoe, or Wilkie's brake harrow, may be successfully adopted. The operation of hoeing or stirring should generally be performed in March, and need not be repeated. When grass-seeds are to be sown among the wheat, the hoeing is an excellent mode of covering them. Weeding the rows should not be neglected, nor delayed later than the beginning of June.*

5038. *Where wheats rise too thin in some places, and too thick in others, whether in rows or broad-cast, the practice of transplanting from the latter to the former has been recommended. This is said to be practised occasionally in Essex and Norfolk, and the time is the end of March. To be attended with success the soil must be in a good state, and the blanks to which the plants are to be transplanted must be stirred up with a trowel or small two-pronged fork. Under such circumstances we have no doubt of the plan being attended with success ; but we are certain that without stirring the soil, the operation will not pay for the expense. Blanks are sometimes filled up by sowing summer wheat, dibbling beans, &c. but these are obviously bad modes ; a better is either to stir the soil well, by the hand pronghoe, and encourage the tillering of the plants, or to stir the soil and then transplant.*

5039. *Top-dressing wheat crops has been recommended in cases where the land is not in a sufficient state of fertility or preparation to bring the crops to perfection. Substances of both the solid and fluid kinds have been made use of for this purpose ; the first consist chiefly of the dung of different sorts of birds, after being brought into a powdery state, bone-dust, soot, peat ashes, and various saline matters. The latter are principally the drainings of dunghills and similar liquid materials. The former should be thinly sown over the crop with as much evenness as possible, as early in the spring as horses can be admitted upon the land without injury ; and if it can be done when the weather is inclined to be moist, it is the better, a roller may then be passed over the crop with advantage. Where the latter substances are made use of, care should always be taken that the plants be not injured by having too large a quantity applied to them. In this practice the expense should be a primary consideration, and small trials first made where dungs have not been used. The proper season for performing the business is the beginning of February.*

5040. *When wheat appears too forward and luxuriant, it is sometimes eat down in April with sheep or even with horses, but this requires great judgment to be effected without injuring the crop.*

5041. *In harvesting wheat, the best farmers both of Britain and the continent agree, that it ought to be cut before it becomes dead ripe. When this is the case, the loss is considerable, both in the field and stack-yard ; and the grain, according to Professor Thaer, produces a less white flour.*

5042. *In ascertaining the proper state, Brown observes, it is necessary to discriminate betwixt the ripeness of the straw, and the ripeness of the grain ; for, in some seasons, the straw dries upwards ; under which circumstance, a field, to the eye, may appear to be completely fit for the sickle, when, in reality, the grain is imperfectly consolidated, and perhaps not much removed from a milky state. Though it is obvious that, under such circumstances, no further benefit can be conveyed from the root, and that nourishment is withheld the moment that the roots die ; yet it does not follow, that grain so circumstanced should be immediately cut : because, after that operation is performed, it is in a great measure necessarily deprived of every benefit from the sun and air, both of which have greater influence in bringing it to maturity, so long as it remains on foot, than when cut down, whether laid on the ground or bound up in sheaves. The state of the weather at the time also deserves notice ; for, in moist, or even variable weather, every kind of grain, when cut prematurely, is more exposed to damage than when completely ripened. All these things will be studied by the skilful husbandman, who will also take into consideration the dangers which may follow, were he to permit his wheat crop to remain uncut till completely ripened. The danger from wind will not be lost sight of, especially if the season of the equinox approaches ; even the quantity dropped in the field, and in the stack-yard, when wheat is over-ripe, is an object of consideration. Taking all these things into view, it seems prudent to have wheat cut before it is fully ripe, as less damage will be sustained from acting in this way than by adopting a contrary practice.*

5043. *The mode of reaping wheat is almost universally by the sickle. When cut, it is usually tied up in sheaves, which it is better to make so small as to be done by bands the length of the straw, than so thick as to require two lengths to be joined for bands. The sheaves are set up in shocks or stooks, each containing in all twelve, or, if the straw be long, fourteen sheaves. In the latter case, two rows of six sheaves are made to stand in such a manner as to be in contact at the top, though in order to admit the circulation of air they are placed at some distance below : along this line, two sheaves more are placed as a covering, the corn end of both being towards the extremities of the line. In a few days of good weather the crop is ready for the barn or stack-yard. In the stack-yard it is built either in oblong or circular stacks, sometimes on frames supported with pillars to prevent the access of vermin, and to secure the bottom from dampness ; and as soon afterwards as possible the stacks are neatly thatched. When the harvest weather is so wet as to render it difficult to prevent the stacks from heating, it has been the practice to make funnels through them, a large one in a central and perpendicular direction,*

and small lateral ones to communicate with it. In the best cultivated counties the use of large barns for holding the crop is disapproved of, not only on account of the expense, but because corn keeps better, or is less exposed to damage of any kind, in a well-built stack.

5044. *The threshing of wheat*, before machines for that purpose were introduced, was an arduous and difficult task. The expense was very considerable; whilst the severity of the labour almost exceeded the power of the strongest man, especially in unfavourable seasons, when the grain adhered pertinaciously to the ear, and could not, without difficulty, be completely loosened and removed. In such seasons, expense was the smallest consideration which influenced the husbandman; it was the quantity of grain unavoidably lost which occupied his attention; and, as it appeared difficult to find out a remedy, most people considered it as an evil which could scarcely be avoided. In short, the loss was great in almost every case, but greater with wheat than any other grain. Every thing of this nature, however, may be prevented, now that threshing machines are introduced, provided the feeder is careful, and proportions the quantity on the board to the strength of the impelling power. Wheat, in fact, is now the cleanest threshed grain; because the length of the straw allows it to be properly beat out before it passes the machine, which sometimes is not the case with short oats and barley. If horses are used as the impelling power, thin feeding is necessary, otherwise the animals may be injured; but where wind or water is employed, the business of threshing is executed speedily, completely, and economically. (*Brown.*)

5045. *In performing the operation*, one man feeds the grain in the straw into the machine, and is assisted by two half-grown lads, or young women, one of whom pitches or carries the sheaves from the bay close to the threshing-stage, while the other opens the bands of every sheaf, and lays the sheaves successively on a small table close by the feeder, who spreads them evenly on the feeding stage, that they may be drawn in successively by the fluted rollers, to undergo the operation of threshing. In the opposite end of the barn or straw-house, into which the rakes or shakers deliver the clean-threshed straw, one man forks up the straw from the floor to the *straw-mow*, and two lads, or young women, build it and tread it down. In a threshing-machine, worked by water or wind, this is the whole expense of hand labour in the threshing part of the operation, and, as a powerful machine can easily thresh from two to three hundred bushels of grain in a working day of nine hours, the expense is exceedingly small indeed. Assuming two hundred and fifty bushels as an average of the work of these people for one day, and their wages to be nine shillings, the expense does not amount to one halfpenny for each bushel of grain. Even reducing the quantity of grain threshed to one hundred and fifty bushels, the easy work of a good machine of inferior size and power, the expense does not exceed three farthings the bushel. But the whole of this must not be charged against the threshing only, the grain being half-dressed at the same time, by passing through one winnowing-machine, which is always attached to a complete threshing-mill; and where a second can be conveniently connected with it, as is commonly the case if the mill is of considerable power, the corn comes down nearly ready for market: so that the threshing, dressing, and building of the straw, with the use of a powerful water-mill, will scarcely cost more than dressing alone when the flail is employed; after every reasonable allowance for the interest of money, and the tear and wear of the machine.

5046. *When grain is threshed with a machine worked by horses*, the expense is necessarily and considerably enhanced. One capable of effecting the larger quantity of work, already calculated on, will require eight good horses, and a man to drive them, who may perhaps require the aid of a boy. The value of the work of eight horses for a day cannot be less than forty shillings, and the wages of the driver may be called two shillings and sixpence. Hence the total expense of threshing two hundred and fifty bushels will amount to 2*l.* 2*s.* 6*d.*; or about two-pence per bushel, when the wages of the attendants are added; still leaving a considerable difference in favour of threshing by the machine, in preference to the flail. Were it even ascertained that the expense of threshing by horses and by the flail is nearly the same, horse-mills are to be recommended on other accounts; such as better threshing, expedition, little risk of pilfering, &c.

5047. *The produce of wheat* must of course vary, according to the soil, climate, culture, and kind grown. Professor Thaer says, that in general it gives double the weight of straw that it does of grain; on elevated grounds something less; and on low grounds something more. The yield of grain in some seasons has been under twenty, while in others it is upwards of thirty bushels the acre, the soil and culture being in every respect the same. The average produce of Britain has been estimated at three, three and a half, and four quarters; and one of the largest crops ever heard of, at ten quarters, and the least at one quarter and a half. The proportion which the corn bears to the straw, in Middlesex, is eleven and a half bushels to a load of thirty-six trusses of thirty-six pounds each, or eleven and a half cwt.; no great deviation from Professor Thaer's general estimate, a bushel of wheat weighing about 60 or 61 pounds.

5048. *To judge of a sample of wheat*, examine by the eye if the grain is perfectly fed or full, plump and bright, and if there is any adulteration proceeding from sprouted grains, smut, or the seeds of weeds; and by the smell, if there is any improper impregnation, and if it has been too much heated in the mow or upon the kiln; and finally, by the feel, to decide if the grain is sufficiently dry, as when much loaded with moisture it is improper for the uses of the miller and baker. In cases where a sample handles coarse, rough, and does not slip readily in the hand, it may be concluded not to be in a condition either for grinding or laying up for keeping. When melilot and wild chamomile abound among the wheat crop, are reaped with it, and undergo fermentation in the rick, the grain will have the flavour of these strong smelling plants. To detect this in the sample, hold the grain close in the hand, moisten it with the breath, and then smell or taste it. This is the practice at Ampthill and other markets in Bedfordshire.

5049. *The yield of wheat in flour* is, on an average, thirteen pounds of flour to fourteen pounds of grain. In the chemical analysis of wheat, Sir Humphrey Davy found that one hundred parts of good full-grained wheat, sown in autumn, yield of starch seventy-seven, and of gluten nineteen; one hundred parts of wheat, sown in spring, seventy of starch, and twenty-four of gluten. American wheats he found to contain more gluten than the British; and, in general, the wheat of warm climates to abound more in gluten and in insoluble parts, and to be of greater specific gravity, harder, and more difficult to grind.

5050. *The uses of wheat* in the baking, culinary, and confectionary arts are well known. It is also used for making starch, by steeping the grain and then beating it in hempen bags. The mucilage is thus mixed with the water, produces the acetous fermentation, and the weak acid thus formed renders the mucilage white. After settling, the precipitate is repeatedly washed, and then moulded into square cakes and kiln-dried. In drying, the cakes separate into flakes, as in the starch of the shops. Starch is soluble in hot water, but not in cold; and hence, when ground down, it makes an excellent hair powder. Its constituents are: carbon, 43.55; oxygen, 49.68; and hydrogen, 6.77 = 100.

5051. *The uses of wheat straw* are various and well known. As fodder it is, according to Professor Thaer, the most nourishing of any; and it makes the best thatch: it is generally preferred for litter, though rye and barley straw are softer: it is used for making bee-hives, horse collars, mattresses, huts, boxes, baskets, and all kinds of what is called Dunstable work; for the cider press; and, among other things, for burning, to procure potash from the ashes. The straw of wheat from dry chalky lands is manufactured into hats for both men and women. For this purpose, the middle part of the tube, above the last joint, is taken; and, being cut into a length of eight or ten inches, is split in two. These splits are then plaited, by females and children, into various kinds of plait or ribands, from half an inch to an inch broad: these, when sewed together according to fancy or fashion, form different descriptions of ladies' bonnets, and the commoner plait and coarser straw of men's hats. The hats are whitened by being placed in the vapour of sulphur. Leghorn hats are made from the straw of a bearded variety of wheat, which some have confounded with rye. It is cultivated on the poorest sandy soils in the neighbourhood of the Arno, between Leghorn and Florence, expressly for this manufacture. It is of humble growth, and not above eighteen inches high; is pulled up when green, and bleached white by spreading and watering on the gravelly banks of the Arno. The straws are not split; but in other respects the manufacture into ribands is the same as at Dunstable in England and in the Orkney Islands.

5052. *The Leghorn manufacture of wheat straw* into the well-known hats has lately been enquired into, and detailed in several publications. The variety of wheat cultivated in Tuscany for this purpose is known as the *grano marzuolo*, or *marzolano*, a variety of summer wheat with long bearded ears. It is cultivated on the sandy hills on both sides of the valley of the Arno. The seed is sown in March, very thick, and pulled when the ear is fully shot, but before the grain is formed. It is then 18 inches high, if the crop is good; it is bleached as we do flax, and afterwards tied up in bundles in the same manner, and carried home, to have the part between the ear and the first fruit in the stalk selected, that being the only part used. (*Gard. Mag.* vol. v. p. 70.)

5053. *To obtain the whiteness so much prized*, the straw is smoked with sulphur previously to being worked; the plait is also smoked; and, lastly, the hat. About Sienna the process is simply a little sulphur set on fire in the bottom of a large chest, bunches of the straw being placed on long hazel rods across, and the lid shut down. Elsewhere the articles are described as being placed in a small close room, in which a chafing dish of sulphur is placed, and set fire to. Sometimes the operation requires to be done twice before it succeeds.

5054. *The straw for use is classed or stapled like our wool*. Children or inferior hands work the coarse thick straw, while good hands work the fine only. Whether fine or coarse, it is only the part on which the spike grows that is made use of; and it is always the same plait, consisting of thirteen straws, which is worked. In the fine plait there is a very great waste of straw, as they reject all that is in the least too thick, and they cut off a considerable part of the straw when it comes near the flower-spike. Fine plait is not accounted good unless very much drawn together; for which end it is worked very wet. The bunches of straw are always put into a small jar, filled with cold water, which stands beside the worker. After being smoked and pressed, the plait is made up into hats by women, who do nothing else; it is not put together by edges, nor overlapped. On the operation of pressing, a great deal depends: there are only two good machines for that purpose in the country. Such is the practice for procuring the hat straw: what they sow for seed is in other ground: not one fourth of the seed is used, and the grain is allowed to come to maturity in the usual way. It is said to be a capital wheat for vermicelli, macaroni, &c., and also for making into bread. (*Gard. Mag.* vol. v. p. 71.)

5055. *The introduction of the grano marzuolo into Britain* has been tried, but not attended with success. Messrs. J. and A. Muir, after various trials, found the straw of rye preferable.

5056. *The mode of plaiting is as follows* — The straws being picked, and put into separate bundles, according to their quality, let thirteen of them be taken and tied firmly together by the seed ends; attach them to any thing, such as the back of a chair, to keep them steady; then take hold of the loose end of the bundle, putting six straws into the one hand, and seven into the other. Take the outermost, and with it cross over two; then carry it behind the next two; and lastly, before the remaining two; after which lay the straw into the other parcel of six. The first parcel of six being now made seven, take the outermost straw of it, and carry it across the bundle, by two, as in the former case, laying at last this seventh straw into the outer parcel as before. It will be understood by this, that the outermost straw of each parcel is always made the acting straw, and that, in the progress of the operation, each of the straws of both parcels is thus employed in its turn.

5057. *As the work goes on*, it will be necessary now and then to join in new straws. Seeing any one needing to be renewed, watch until it becomes the acting straw; and, when it is to be laid into the other parcel, after performing its round, lay it up over the piece of plait, instead of putting it into the

parcel as formerly, and in place of it lay in a new straw, which is then to be used exactly as if it were the old one.

5058. *If by chance, in working, any of the straws should break*, a thing which can scarcely happen with winle-straes to any but the outermost straw, and to it only through want of attention, it may be remedied without any more trouble than putting in a new one in its place; and though the outside of the plait with the old and new straw should exhibit the appearance of a broken loop, yet, in the knitting up of the work, it can easily be so managed that the defect shall be entirely concealed.

5059. *The knitting* need not be begun till as much of the plait is made as may be supposed sufficient to form a hat, as an entire hat of any desired shape may be made up of a single piece of plait. About 70 or 80 yards will be sufficient to make a lady's hat.

5060. *Outside and inside of the hat.* In joining in new straws during the plaiting, the ends of the new and old having been kept on the upper side of the plait, this will therefore be made the inside of the hat. After twisting and turning the plait a little, to make it form the round piece for the top, the plait will be found to lie with the one side to the other, like the teeth of two saws turned to each other; and then so to unite these two opposite sides that they may present the appearance of one piece, begin to sew by putting the needle in through the sort of stitch or loop on the outside of the plait, inserting the needle from below. Take the stitch of the opposite piece in exactly the same way, and, after four or five stitches of each side are taken on the thread, draw it up tightly, so that the stitches of both may be brought firmly the one beside the other. In this manner, in the course of the operation, it will soon be seen that the place where the seam is can scarcely be discovered from the rest of the plait.

5061. *To sew the crown of the hat* so that it may be quite plain, every stitch of the one side must not be taken with every one of the other, but every second or third only of one of the sides, till the work get on a little.

5062. *The blocking of a hat* may be done with any round piece of smooth stick that will fill it. After the hat is well steeped, and put on the block, it may be made quite smooth by beating it gently with a hammer. (*Quar. Jour. Ag.* vol. i. p. 294.)

5063. *The diseases of wheat* are the rust, smut, or black mildew, the latter including what is vulgarly called blight. These have been already treated of in our view of the vegetable economy, and we shall merely offer a few practical observations on the smut and mildew.

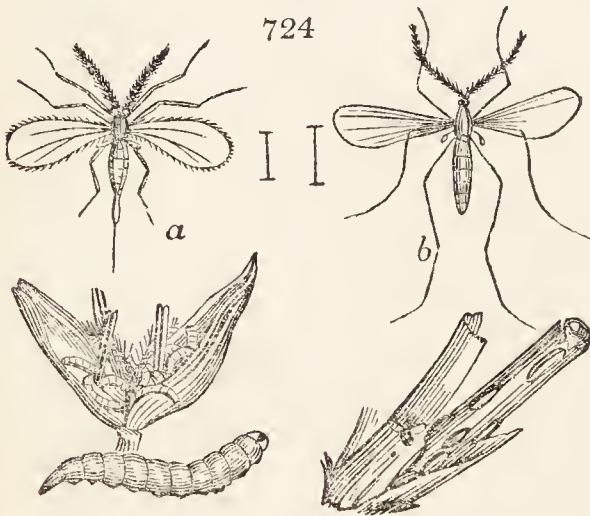
5064. *The proximate cause of smut*, in whatever manner the smut may be transmitted from the seed pickle in the ground to the ear, it seems certain, is in general the infection of the seed by the dust of the smut-ball, which B. de Jussieu first conjectured to be *Lycoperdon globosum*, and which M. Prevost ascertained to be a microscopic vegetable of some sort; and that though the most careful washing, even with the application of caustics, may not in every case insure against smut, yet if the seed be prepared in the way already mentioned, the disease will never prevail to such a degree as to affect materially the value of the crop. This is all that cultivators need to know, and all, perhaps, in the present state of science, that can be known, of the cause and prevention of smut. See an article at length on this subject in the *British Farmer's Magazine*, vol. iii. p. 176.

5065. *Mildew* is a much more destructive distemper than smut; and, as it is probably occasioned by a peculiar state of the atmosphere during the periods of flowering and ripening, it is likely to baffle all attempts at prevention. The prevalence of heavy fogs or mist, drizzling rains, and sudden changes in the temperature, have been assigned as the causes of mildew; and as it has been found that open airy exposures are much less affected than low sheltered lands, in years when mildew prevails most generally, the disorder may perhaps be somewhat diminished by drilling, which admits a freer circulation of air. Spring or summer wheat is less liable to mildew than the winter species, though it does not always escape. Minute parasitical Fungi, *Puccinia Graminis* (*Enc. of Plants*), are commonly detected on the straw of mildewed wheat; and there cannot be the least doubt that the barberry bush, and probably several other shrubs on which these Fungi abound, have a powerful influence in communicating the disease to a certain distance. (*Sir Joseph Bankes on Mildew*, and *Com. to the B. of Agr.* vol. vii.)

5066. *The wheat fly* has, of late years, been one of the greatest enemies to the wheat crop in Scotland. In North America this insect, or one of the same family, has been known for many years, more especially in New England; and its alarming ravages are depicted from time to time in the newspapers, under the name of the Hessian fly. In the modern nomenclature, the Rev. W. Kirby informs us that the wheat fly, formerly the *Tipula tritici* Lin., is now the *Cecidomyia tritici* (*fig. 724. a*), and the Hessian fly the

C. destructor (*b*). The wheat fly generally makes its appearance about the end of June; and, according to the observations of Mr. Shirreff, they exist throughout a period of thirty-nine days. The hue of the fly is orange, the wings transparent, and changing colour according to the light in which they are viewed. It lays its eggs within the glumes of the florets, in clusters varying in number from two to ten, or even fifteen; and the larvæ feed upon the grain. "They are produced from the eggs in the course of eight or ten days: they are at first perfectly transparent, and assume a yellow colour in a few days afterwards. They travel not from one floret to another, and forty-seven have been numbered in one. Occasionally there are found in the same floret larvæ and a grain, which is generally shrivelled, as if deprived of nourishment; and although the pollen may furnish the larvæ with food in the first instance, they soon crowd around the lower part of the germen, and there, in all probability, subsist on the matter destined to form the grain." (*Mag. Nat. Hist.* vol. ii. p. 450.) The larvæ are preyed on by the *Céræphron destructor*, an ichneumon fly, which deposits its eggs in the body

of the larvæ of the wheat fly; and this is the only check hitherto discovered for preventing the total destruction of the wheat crops attacked by the *Cecidomyia*. Mr. Shirreff, speaking of this ichneumon, says, "I could not determine if it actually deposits its eggs in the maggot's body; but there can be no doubt, however, of the ichneumon piercing the maggots with a sting; and, from stinging the same maggot repeatedly, it is probable the fly delights to destroy the maggots, as well as to deposit eggs in their bodies. The carwig, also, devours the maggots as food. (*Brit. Farm. Mag.* vol. iii. p. 493.) Mr. Gorrie estimates the loss sustained by the farming interest in the Carse of Gowrie district alone, by the wheat fly, at 20,000*l.* in 1827, at 30,000*l.* in 1828, and at 36,000*l.* in 1829. (*Perth Miscellany*, vol. i. p. 42.) The same writer, in May 1830, thus depicts the prospect of the wheat crop in the Carse of Gowrie:—"The *Cecidomyia* are still alive in formidable legions. That the flies will this season be in as great plenty as ever, is now quite certain; that they will lay their eggs on no other plant than those of the wheat genus, is also true; the only chance of escape is in the time the pupæ appear the fly state. Should this sunny weather bring them forward within a fortnight or three weeks from this date, the greater part will have perished before the wheat is



in the ear; or should the earing take place before the flies appear, then only the late or spring-sown wheats will suffer: but these appear slender chances. We know the history and habits of the insect too well to believe that either mist, or rain, or dew, or drought, will either forward or retard their operations, if the main body appear about the time the wheat comes in the ear. In addition to that vile gnat, our neighbours in the Lothians are threatened with a no less formidable invader in the *A'cius pumiliarius*, which, as we are informed on respectable authority, have already commenced their depredations, and are thinning the wheat plants rather liberally in that quarter. It, like the Hessian fly in America, attacks the under joints, which become habitations for the young larvæ. As far as our observation extends, this pest has not yet reached us in noticeable numbers." (*Country Times*, May 17. 1830.)

5067. *The culture of summer wheat* differs from that of winter or spring-sown winter wheat, in its requiring a more minutely pulverised and rather richer soil. It need not be sown sooner than April, and it advances so rapidly to maturity that it hardly affords time for hoeing (if sown in rows), or harrowing and rolling. When grass or clover seeds are sown on the same ground, they are sown immediately after the wheat, and harrowed in with a light harrow or rolled in. In this respect, and indeed in all others, the preparation of the soil and sowing of this grain are the same as for barley.

5068. *The produce of summer wheat*, both in grain and straw, is considerably less than that of winter wheat: the straw is only fit for litter or inferior fodder; the flour produced by the grain is rather coarser and darker than that of common wheat. Of course this sort of wheat cannot, as already observed, be recommended for general culture.

SECT. II. *Rye*. — *Secale cereale* L.; *Triandria Digýnia* L., and *Gramineæ* J. *Seigle*, Fr.; *Rogon*, Ger.; *Segale*, Ital.; and *Centeno*, Span. (fig. 725.)

5069. *Rye*, according to some, is a native of Crete; but it is very doubtful whether any country can be now ascertained to be its native soil. It has been cultivated from time immemorial, and is considered as coming nearer in its properties to wheat than any other grain. It is more common than wheat on most parts of the continent, being a more certain crop, and one which requires less culture and manure. It is the bread corn of Germany and Russia. In Britain it is now very little grown, being no longer a bread corn, and therefore of less value to the farmer than barley, oats, or peas. Many consider it the most impoverishing of all corn crops.



5070. *The varieties* of rye are not above two, known as winter and spring rye: but there is so little difference between them that spring rye sown along with winter rye can hardly be distinguished from it.

5071. *The soil* for rye may be inferior to that chosen for wheat: it will grow in dry sandy soils, and produce a tolerable crop; and, on the whole, it may be considered as preferring sands to clays. The preparation of the soil should be the same as for wheat. According to Professor Thaer, rye abstracts 30 parts in 100 of the nutriment contained in the soil on which it is grown.

5072. *The climate* for rye may be colder than for wheat; but it is rather more injured by rains during winter, and equally injured by moist weather during the flowering season.

5073. *Rye* is sown either in autumn or spring, and either broad-cast or in drills: two bushels and a half is the usual allowance when it is sown broad-cast. As it vegetates more slowly than wheat, it should be sown when the soil is dry; a wet soil being apt to rot the grain before it has completely germinated. No pickling or other preparation is given.

5074. *The after culture, harvesting, and threshing* are the same as for wheat; and the produce in grain is, under similar circumstances, equal in bulk; but in straw it is greater in rye than in any other grain. Sir H. Davy found, in 1000 parts of rye, 61 parts of starch and five parts of gluten. Professor Thaer says rye is the most nourishing grain next to wheat. It contains an aromatic substance, which appears to adhere more particularly to the husk, since the agreeable taste and smell peculiar to rye bread are not found in that which is made from rye flour that has passed through a very fine bolting-cloth; while the fragrance may be restored by a decoction of rye bran in the warm water used to make the dough. This substance, Thaer says, seems to facilitate digestion, and has an action particularly refreshing and fortifying on the animal frame.

5075. *The use of rye* is chiefly for bread, especially for gingerbread. It is also used in the distilleries; and the straw is used for the same purposes as that of wheat, except that it is useless as fodder. Some prefer it for thatching and litter, and also for collar-making: it is also employed in Dunstable work. Tanners are said to use it in some districts.

5076. *Rye* is sometimes sown as a green crop, with a view of affording some keep for sheep early in the spring, and also for being ploughed in as manure; but that husbandry

must be bad or unfortunate which requires recourse to either mode. In some districts it is customary to sow the head lands of wheat fields with rye, which is said to keep poultry from penetrating to the wheat.

5077. *The manufacture of rye straw into plait for hats* is a new application, for which the public are indebted to Messrs. J. and A. Muir of Greenock, manufacturers of straw hats in imitation of those of Leghorn. Messrs. Muir had previously tried rye grass, crested dog's-tail grass, sweet-scented vernal grass, and the straw of wheat, raised both from British and foreign seed, without success. At last the idea of employing rye straw was suggested to them; and they now send annually to their establishment in the Orkney Islands (founded by an English gentleman about 1820) "from 40 to 45 bolls, which are sown on about twelve English acres of sandy soil, manured with sea-weed. Several acres of heath for bleaching the straw, and water for steeping it, are required in the neighbourhood of the rye fields. The rye is cut when the seed is beginning to form; and it is necessary to attend to the precise time, for ten days too early or too late produce a considerable difference in the look of the straw. When the rye is cut, women are employed to tie it at the lower extremity in handfuls; it is then put into boxes, and covered with boiling water, in which it remains for half an hour. After this it is spread out upon the heath in a fan form, and turned twice daily, until the bleaching, which takes about ten days, is completed. If exposed to much rain while bleaching, the straw is injured in colour, and rendered very liable to take mildew. It is of great importance to have the crop well housed."—"The seed of the rye is sown in April, in mossy ground, recently rendered arable; and if the season is at all favourable, it comes into flower in July, when it is cut down. The whole stem is then immersed in boiling water, in a trough made for the purpose, and remains in this state for two hours. When taken out, it is spread upon a grass field, and exposed to the sun, till it is properly bleached, which requires from two to four days, according to the weather. When bleached, the stalk is divided into separate parts at each joint, and put up into bundles by the lengths. In this manner, the bundles lie in a proper place till wanted by the plaiters. This last process is done chiefly by old people, who are unable for the finer work, or by those pupils who have only lately joined the manufactory. (*Trans. Highl. Soc.* vol. vii. pp. 286. and 289.) The mode of plaiting has been already described. (§ 5056.)

5078. *Rye is less subject to disease than most other grain*, and is even sown among wheat and round wheat fields from an idea that it will keep off blight and mildew as well as poultry.

5079. *The spur or ergot of rye* is by some considered as a fungus, a species of *Scleròtium*, somewhat analogous to that which produces the smut. It is not peculiar to rye, but it is very seldom found on any other gramineous plant. "It is a production of the seeds; is long, horny, and cartilaginous; and is sometimes straight, at others curved; sometimes it is found more than two inches in length. The resemblance of this substance to cocks' spurs has given it the name by which it is distinguished. On breaking a spurred seed, you find within it a substance of a dull white colour adhering to the violet skin that surrounds it. Rye thus attacked cannot germinate. M. Tessier remarked that the most rainy years were the most productive of this disease; that the soils on which most spurred rye grew were most moist; that high grounds were nearly free from them, unless when the furrows prevented the water from running freely off, while the lower parts of the same field produced more than the upper parts." (*Brit. Farm. Mag.* vol. iii. p. 302.) In France a disease, called the chronic or dry gangrene, has been produced by eating ergot. This disease is also known in Switzerland, where it was observed that most animals refused to eat diseased rye, or rye affected with the cockspur, as it is called. The Royal Society of Medicine at Paris employed M. Tessier, a distinguished agricultural writer and man of science, to go into the countries where the dry gangrene prevailed, and collect a sufficient quantity of the ergot or cockspur rye for experiments. The result confirmed the opinion of those who attributed the disease to the cause assigned. "France afforded, also, a simple explanation of the fact that persons might live for a considerable time upon rye affected with the cockspur, without suffering any sensible injury from its use; since, in all the animals upon which it was tried experimentally, a given quantity was required to produce the specific effect; and they suggested the only measure, that of separating the diseased from the sound rye, which could prevent so great a national calamity as that which has been so often produced by its use." The spurred rye occasionally occurs in this country, but there are no instances recorded of its producing any such effects as it is said to do in France; but in the *Philosophical Transactions* Dr. Wollaston has narrated several cases in which dry gangrene was produced in one family by partaking of damaged wheat; and nearly the same effects were produced in a family in Wiltshire by the *Lolium temulentum* entering largely into the composition of bread. (*Stephenson and Churchill's Med. Bot.* art. *Secale*.) M. Lagasca states that the ergot is covered with a thin pellicle and filled with a grey powder. It is collected in Spain by women and children, who wade in the fields of standing rye for the purpose, and with their utmost vigilance can obtain it but in very small quantities, in consequence of which it sells high as an article of the materia medica. (*Brit. Farm. Mag.* vol. iii. p. 158.) Medicinally it is used in uterine diseases.

SECT. III. *Barley*. — *Hórdeum* L.; *Triándria Digýnia* L., and *Gramíneæ* J. *L'Orge*, Fr.; *Gerste*, Ger.; *Orzo*, Ital.; *Byg*, Dan. and Swed.; and *Cebada*, Span.

5080. *Barley*, though less calculated for a bread corn than rye, may be considered as next in value to wheat in Britain. Of what country it is a native is unknown. Some assign it to Tartary, others to Siberia, and even Scotland has been mentioned. It has been cultivated from the earliest antiquity, and was much in use among the Romans, both as food for soldiers and horses. In Sweden and Lapland it is more cultivated than any other grain, on account of its requiring to be so short a period in the soil; sometimes not longer than six weeks, and seldom more than seven or seven and a half. In Spain and Sicily they have two crops a year on the same soil: one is sown in autumn and ripens in May; and the other is sown in May and reaped in autumn. In Britain barley is a tender grain, and easily hurt in any of the stages of its growth, particularly at seed time: a heavy shower of rain will then almost ruin a crop on the best prepared land; and in all the after processes greater pains and attention are required to insure success than in the case of other grains. The harvest process is difficult, and often attended with danger; even the threshing of it is not easily executed with machines, because the corn generally adheres to the grain, and renders separation from the straw a troublesome task.

5081. *Species and varieties.* (fig. 726.) There are six species and subspecies of this grain in cultivation besides varieties. These are,—

- | | |
|---|--|
| 1. <i>Hórdeum vulgare</i> , Spring barley (<i>a</i>). | 4. <i>Hórdeum</i> dístichon, Common or long-eared barley (<i>c</i>). |
| 2. <i>cœléste</i> , Siberian barley. | 5. dístichon nudum, Naked barley. |
| 3. hexástichon, Winter barley (<i>b</i>). | 6. Zeocriton, Sprat or battledore (<i>d</i>). |

The second and fifth sorts are allowed to be subspecies or varieties of the first and fourth, and indeed there can be little doubt that the whole do not constitute more than one species.



5082. *The spring barley or early barley (a), Orge carrée, Sucrion de printemps, Fr.*, is distinguished by its double row of beards or awns standing erect, and its thin husk, which renders it favourable for malting. This is the sort principally cultivated in the southern and eastern districts of both England and Scotland, and of which the farmers make two sorts, viz. the common, and the rath-ripe barley: but these two sorts are in reality the same; for the rath-ripe is only an alteration of the common barley, occasioned by being long cultivated upon warm gravelly soils. The seed of this, when sown on cold or strong land, will, the first year, ripen near a fortnight earlier than the seed taken from strong land, and therefore the farmers in the vales generally purchase their seed-barley from the warm or gravelly lands; for, when preserved in the vales two or three years, it becomes full as late in ripening as the common barley of their own product: on the other hand, the farmers on warm lands are also obliged to procure their seed-barley from the strong lands, otherwise their grain would degenerate in bulk or fulness, which by this change is prevented.

5083. *The Siberian barley, Orge céleste, Fr.*, and *Himmel gerste, Ger.*, is a variety of early barley with broader leaves, and reckoned more productive than the other. It is much grown in the north of Europe, and was introduced to this country in 1768, but is believed to be now lost or merged in the parent species.

5084. *Winter barley, late barley, or square barley (b), Orge carrée d'hiver, Escourgeon, Fr.*, has the grains disposed in four or in six rows, large and thick skinned. It is chiefly cultivated in the north of England and in Scotland, on account of its hardiness; but from the thickness of its rind it is ill adapted for malting, and is going out of use.

5085. *Bigg, byg, or barley big*, is a variety of winter barley known by always having six rows of grains, by the grains being smaller and the rind thicker, and by its being earlier than the parent variety. Professor Martyn says, he has frequently counted forty-two grains on one ear of bigg, when common or long-eared barley had only twenty-two.

5086. *Common or long-eared barley (c)*, is known by its very long spike or ear, flatted transversely, greater in breadth than thickness, with chaff ending in an awn sixteen times the length of the grain. This sort is cultivated in many parts of England and Scotland; though some object to it because the ears being long and heavy they think it apt to lodge.

5087. *Naked barley, or wheat barley, Orge nue à deux rangs, Fr.*, is known by the grain separating easily from the chaff, and is by some considered as nothing else than spelt wheat, which it greatly resembles. It does not appear to be cultivated at present in any part of Britain.

5088. *Sprat, or battledore barley (d), Orge éventail, Orge-riz, Fr.*, is known by its low stature, coarse straw, short broad ears, and long awns. The long awns and closeness of the ears protect it better from birds than most other sorts, but as the straw is scanty and of little use it is not much cultivated.

5089. Besides these sorts there are some *local varieties*, as Thanet barley, Putney barley, &c. which are merely names given to the varieties common in those places. The Thanet is the winter, and the Putney the sprat barley.

5090. *New varieties* may be procured by selection or crossing, as in the case of wheat. (5009.)

5091. *In choosing a sort of barley* for cultivation, regard must be had to the soil and climate. The hardiest may be considered the winter barley, and the earliest, and perhaps the best, is the spring barley. The long-eared is also a much esteemed variety.

5092. In choosing from any particular variety, the best grain for sowing is that which is free from blackness at the tail, and is of a pale lively yellow colour, intermixed with a bright whitish cast; and if the rind be a little shrivelled, it is so much the better, as it shows that it has sweated in the mow, and is a sure indication that its coat is thin. The husk of thick-rinded barley being too stiff to shrink, will lie smooth and hollow, even when the flour has shrunk from it within. The necessity of a change of seed from time to time, by sowing that of the growth of a different soil, as it has been observed, is in no instance more evident than in the culture of this grain, which otherwise becomes coarser and coarser every year. But in this, as well in all other grain, the utmost care should be taken that the seed is full bodied.

5093. *The best soil for barley* is a light rich loam, finely pulverised. It will neither grow well on a sandy or soft soil, nor on strong clays, such as are suitable for wheat.

5094. *The preparation of the soil* is sometimes by a naked fallow, but generally by a turnip fallow; sometimes it is taken after peas and beans, but rarely by good farmers either after wheat or oats, unless under special circumstances.

5095. *When sown after turnips* it is generally taken with one furrow, which is given as fast as the turnips are consumed, the ground thus receiving much benefit from spring frosts. But often two or more furrows are necessary for the fields last consumed; because, when a spring drought sets in, the surface, from being poached by the removal or consumption of the crop, gets so hardened as to render a greater quantity of ploughing, harrowing, and rolling necessary than would otherwise be called for. When sown after beans and peas, one winter and one spring ploughing are usually bestowed; but, when after wheat or oats, three ploughings are necessary, so that the ground may be put in proper condition. These operations are very ticklish in a wet and backward season, and rarely in that case is the grower paid for the expense of his labour. Where land is in such a situation as to require three ploughings before it can be seeded with barley, it is better to summer fallow it at once, than to run the risks which seldom fail to accompany a quantity of spring labour. If the weather be dry, moisture is lost during the different processes, and an imperfect germination necessarily follows: if it be wet, the benefit of ploughing is lost, and all the evils of a wet seed-time are sustained by the future crop. (*Brown.*)

5096. *To whatever crop barley succeeds*, the harrow and roller, when the plough alone is insufficient, should be employed in reducing the soil to a considerable degree of fineness. In most cases more than one earth is given; though, after a winter furrow, the grubber may be used in spring instead of the plough. After turnips, eaten on the ground by sheep, the land, being consolidated by their treading, sometimes receives two ploughings; but, if only one, it should be well harrowed and rolled; and it is often finished by harrowing after the roller, especially if grass-seeds be sown, which are covered by this last harrowing. Barley is sometimes sown on the first ploughing, and covered by a second shallow ploughing. As it is found of great importance, with a view to speedy and equal vegetation, that the ground should be fresh and moist, barley is generally sown upon what is termed *hot-fur*, that is, as soon as possible after it is turned up by the plough.

5097. *Manure* can seldom be given with advantage to a crop that occupies the soil so short a period as barley, and therefore it generally is sown on land which has been enriched for a preceding crop.

5098. *The climate* in which barley delights is warm and dry. There are instances of a crop being sown and ripened without having enjoyed a single shower of rain; but gentle showers from the time it is sown till it begins to shoot into the ear, are favourable; while heavy rains at any period, and especially immediately after sowing, or during the blossoming, ripening, and reaping seasons, are highly injurious.

5099. *The best season for sowing* barley is considered to be from the beginning of April to the middle of May; but bigg may be sown either in autumn to stand the winter, or as late as the first week of June. In England, the winter or four-rowed barley is frequently sown in autumn, and stands the most severe winters. With respect to the lateness at which bigg and summer barley may be sown, much depends on the sort of weather which occurs during the first three weeks after sowing.

5100. *When barley is sown late* it is sometimes steeped in common water to promote its germination; but it is seldom pickled or otherwise prepared. The advantages of steeping are, procuring an equal germination, and consequently ripening, and getting the start of weeds. The following directions are given for performing the operation:—First, take out about one-third of the contents of the sacks of seed barley or bear to allow for the swelling of the grain; lay the sacks with the grain to steep in clean water; let it be covered with it for at least twenty-four hours; when the ground is very dry, and no likelihood of rain for two or three days, it is better to lie thirty-six hours. Sow the grain wet from steeping without any addition. The seed will scatter well as clean water has no tenacity; only the sower must put in a fourth or a third more seed in bulk than is usual of dry grain, as the grain is swelled in that proportion. Harrow it in as quickly as possible after it is sown; and, though not necessary, give it the benefit of a fresh furrow if convenient. You may expect it up in a fortnight at farthest. (*Brown.*)

5101. *The quantity of seed* is different in different cases, according to the quality of the soil and other circumstances. Upon very rich lands, eight pecks per acre are sometimes sown; twelve is very common; and upon poor land, more is sometimes given.

5102. *Whether the practice of giving so small a quantity of seed to the best lands is advantageous* or the reverse, seems a disputed point among the best farmers. That there is a saving of grain there can be no doubt; and that the bulk may be as great as if more seed had been sown, there can be no little question. Little argument, however, is necessary to prove that thin sowing of barley must be attended with considerable disadvantage; for if the early part of the season be dry, the plants will not only be stinted in their growth, but will not send out offsets; and if rain afterwards fall, an occurrence that must take place some time during the summer, often at a later period of it, the plants begin to stool, and send out a number of young shoots. These young shoots, unless under very favourable circumstances, cannot be expected to arrive at maturity; or if their ripening be waited for, there will be a great risk of losing the early part of the crop, a circumstance that frequently happens. In almost every instance an unequal sample is produced, and the grain is for the most part of an inferior quality. By good judges, it is thought preferable to sow a quantity of seed sufficient to ensure a full crop, without depending on its sending out offsets: indeed, where that is done, few offsets are produced, the crop grows and ripens equally, and the grain is uniformly good. (*Brown on Rural Affairs.*)

5103. *The modes of sowing* barley are either broad-cast, or in rows by the drill or ribbing. The broad-cast mode is almost universally adopted; unless in lands much infested with annual weeds, where drilling and hand-hoeing, and in particular cases horse-hoeing, may be employed with advantage.

5104. *The only culture* which barley requires while in a growing state, is hoeing and weeding if in rows, and weeding alone if broad-cast. Sometimes barley is rolled to compress a soft soil and exclude the drought, and when very thick it may be first harrowed and then rolled. Grass seeds and clover are sown with the grain before the last harrowing, when the broad-cast mode is adopted; and immediately before hoeing, when the barley is in rows. The former is much the best mode for insuring a strong plant of clover.

5105. *Eating down barley*, which from winter or very early sowing is over-luxuriant, is practised in some districts, but it is alleged that mowing is much better than feeding it; because the scythe takes off only the rank tops, but the sheep feed upon all indifferently; nor should they even, in any case, be left

upon it too long, because, being particularly fond of the sweet end of the stalk next the root, they bite so close as to injure the future growth of the plant.

5106. *Barley is ripe* when the red roan, as the farmers term it, meaning a reddish colour on the ear, is gone off; or when the ears droop, and fall, as it were, double against the straw, and the stalks have lost their verdure; but in the latter case it is too ripe.

5107. *In the harvesting of barley* more care is requisite than in taking any of the other white crops, even in the best of seasons; and in bad years it is often found very difficult to save it. Owing to the brittleness of the straw, after it has reached a certain period it must be cut down; as, when it is suffered to stand longer, much loss is sustained by the breaking of the heads. On that account it is cut at a time when the grain is soft, and the straw retains a great proportion of its natural juices, consequently requires a long time in the field before either the grain is hardened or the straw sufficiently dry. When put into the stack sooner it is apt to heat, and much loss is frequently sustained.

5108. *Barley is generally cut down* in England with the cradle scythe, and either tied up or carted home loose after lying in the swath some days to dry. It is not apt to shed; but in wet weather it will be likely to spout or grow musty; and therefore every fair day after rain it should be shaken up and turned: and when it is tolerably dry, let it be made up into shocks; but be careful never to house it till thoroughly dry, lest it mow-burn, which will make it malt worse than if it had spired in the field. It is remarked by Lisle, that poor thin barley should be cut a little sooner than if the same plants were strong and vigorous; as the straw, when the plants are full ripe, in such cases will not stand against the scythe. In this situation, barley in particular should lie in swath till it is thoroughly dry. Some of his barley, which lay out in swath five or six days in very fine weather, though both blighted and edge-grown, grew plump, and acquired very near as good a colour as the best. He reckons short scythes the best for mowing lodged or crumpled corn, because they miss the fewest plants; and observes, that a bow upon the scythe, which carries away the swath before it, is preferable to a cradle, the fingers of which would be pulled to pieces by the entangled corn, in drawing back the scythe. In Scotland and Ireland it is generally reaped with the sickle, bound in sheaves, and set up in shocks.

5109. *In stacking barley* many farmers make an opening in the stack from top to bottom. This opening is generally made by placing a large bundle of straw in the centre of the stack, when the building commences, and in proportion as it rises the straw is drawn upwards, leaving a hollow behind; which, if one or two openings are left in the side of the stack near the bottom, insures so complete a circulation of air, as not only to prevent heating, but to preserve the grain from becoming musty.

5110. *The threshing and dressing of barley* require more labour than those of any other grain, on account of the difficulty of separating the awns from the ears. For this purpose some threshing machines are furnished with what is called a hummelling machine, already described (2799.): and where this is wanting, it is customary to put the grain, accompanied with a portion of threshed straw, a second time through the machine. Where barley has been mown, the whole of the straw requires to be twice threshed, independently of the necessity of getting rid of the awns.

5111. *The produce of barley*, taking the average of England and the south of Scotland, Donaldson considers, might be rated at thirty-two bushels; but when Wales and the north of Scotland are included, where, owing to the imperfect modes of culture still practised, the crops are very indifferent, the general average over the whole will not probably exceed twenty-eight bushels the acre. Middleton states it as varying in England from fifteen to seventy-five bushels per acre. The average produce of the county of Middlesex, he says, is about four quarters of corn and two loads of straw per acre.

5112. *The uses of barley* are various. In Wales, Westmorland, Cumberland, and in the north, as well as in several parts of the west of Scotland, the bread used by the great body of the inhabitants is made chiefly from barley. Large quantities of the barley cultivated in England are converted into beer, ale, porter, and what is called British spirits, as English gin, English brandy, &c. The remainder, beyond what is necessary for seed, is made into meal, and partly consumed in bread by the inhabitants of the above-mentioned districts, and partly employed for the purpose of fattening black cattle, hogs, and poultry. There is a much greater share of the Scotch barley consumed in distillation, in proportion to the quantity cultivated, than of the English. Exclusive of what is used for seed, the Scotch barley is either converted into beer or ale; or made into pot-barley, or into meal, for the use of the inhabitants in the more remote and less cultivated parts of the kingdom; or, lastly, into whisky. In *The Report of Middlesex* it is stated, that much of the most ordinary barley is given to poultry: the rest is sold to the maltsters, except so much as is reserved for seed.

5113. *But malt is the great purpose to which barley is applied* in Britain. To understand the process of malting, it may be necessary to observe that the cotyledons of a seed, before a young plant is produced, are changed by the heat and moisture of the earth into sugar and mucilage. Malting grain is only an artificial mode of effecting this by steeping the grain in water and fermenting it in heaps, and the arresting of its progress towards forming a plant by kiln drying, in order to take advantage of the sugar in distillation for spirit or fermentation for beer. The grain of barley contains starch and sugar; and the chemical constituents of both these ingredients are very nearly alike. In the process of malting, a portion of the starch is converted into sugar, so that the total quantity of sugar, and consequently the source of spirit, is increased by the transformation.

5114. *To choose a proper sample of barley for malting*, observe the directions given for choosing seed barley. (5091.)

5115. *Of pot-barley* there are two sorts, pearl and Scotch; both are produced by grinding off the husk, and the pearl barley is produced by carrying the operation so far as to produce roundness in the kernel. It is used in soups, gruels, and medicinal drinks.

5116. *Barley meal* is ground like oatmeal or flour; the coarser sort, with the bran, is used for fattening live stock, especially pigs and poultry; but fine bolted barley flour, made into a thin pottage or pudding, and spread out in thick cakes, and toasted on a hot plate of metal, forms a light breakfast bread, much esteemed in some parts of Scotland. It is served in a recent state, hot, and spread with butter and honey, and eaten in several folds. Two parts of barley flour, one of wheat flour, and one of rye, are said to make a light and very agreeable loaf of bread.

5117. *The produce of barley in flour* is 12lbs. to 14lbs. of grain. Sir H. Davy found 1000 parts of barley meal to afford 920 parts of soluble or nutritious matter; viz. 790 of mucilage or starch, 70 of sugar, and 60 of gluten.

5118. *Barley straw* is chiefly used for litter and packing; it is unfit for thatch or rope-making, and of little value as fodder.

5119. *The diseases of barley* are few, and chiefly smut, but of quite a different species from that which affects the wheat, and one which it is found cannot be prevented by pickling and liming.

SECT. IV. *The Oat.* — *Avèna sativa* L.; *Triándria Digýnia* L., and *Gramíneæ* J. *L'Avoine*, Fr.; *Haber*, Ger.; *Vena*, Ital.; and *Avena*, Span.

5120. *The oat* is a very useful grain, and more peculiarly adapted for northern climates than either wheat, rye, or barley. Its native country is unknown, unless the wild oat be considered as the parent species, which is highly probable. The culture of the oat in France is chiefly confined to latitudes north of Paris. It is scarcely known in the south of France, Spain, or Italy; and in tropical countries its culture is not attended to. In Britain it has long been very generally cultivated, formerly as a bread corn, but now chiefly as horse-food. Of all the grain this is the easiest of culture, growing in any soil that admits of ploughing and harrowing.

5121. *The varieties of oats* are more numerous than those of the other grains, and some of them are very distinctly marked. The principal are as follows: —

5122. *The white oat or common oat* (fig. 727. a), *Avoine blanche*, Fr., in most general cultivation both in England and Scotland, and known by its white husk and kernel.



5123. *The black oat*, *Avoine à grappe noir*, Fr., known by its black husk; cultivated on poor soils, in the north of England and Scotland.

5124. *The red oat*, known by its brownish red husk, thinner and more flexible stem, and firmly attached grains. It is early, suffers little from winds, meals well, and suits windy situations and late climates. It is understood to have originated in Peebleshire, on the estate of Magbie-hill, by which name it is sometimes known.

5125. *The Poland oat*, known by its thick white husk, awnless chaff, solitary grains, short white kernel, and short stiff straw. It requires a dry warm soil, but is very prolific. The black Poland oat is one of the best varieties; it sometimes weighs 50lbs. per bushel. It is, however, very liable to be shed by the wind after it begins to ripen; it requires a fine dry tilth.

5126. *The Friezland or Dutch oat*, has plump, thin-skinned, white grains, mostly double, and the large one sometimes awned. It has longer straw than the Poland, but in other respects resembles it.

5127. *The potato oat* has large, plump, rather thick-skinned, white grains, double and treble, with longer straw than either of the last two sorts. It is almost the only oat now raised on land in a good state of cultivation in the north of England and south of Scotland, and usually brings

a higher price in the London market than any other variety. It was discovered growing in a field of potatoes in Cumberland, in 1788; and from the produce of the single stalk which there sprung up by accident, probably from the manure, has been produced the stock now in general cultivation.

5128. *The Georgian oat*, is a large, grained, remarkably prolific variety introduced from Georgia, by R. Barclay, Esq. of Bury Hill, to Britain and the north of Europe. On rich soil in good tilth, Mr. Barclay finds it yield more grain per acre than the potato oat or any variety whatever.

5129. *The Siberian or Tatarian oat* (b), is considered by some as a distinct species. The grains are black or brown, thin and small, and turned mostly to one side of the panicle; and the straw is coarse and reedy. It is little cultivated in England, but found very suitable for the poor soils and exposed situations on the sides of the Dublin and Wicklow hills.

5130. *A variety called the winter oat*, *Avoine d'hiver*, Fr., has lately come into notice in some parts of England, but we have not been able to ascertain its origin. Mr. Bennett of Chaxhill, near Gloucester, sows two bushels per acre in October; finds the plants very luxuriant at Christmas, tillering like wheat: he depastures them with ewes and lambs all the spring, and then shuts them up, and reaps an ample crop early in August. The grain is rather longer than that of the white oat, and the colour rather lighter than that of the black oat; Mr. Bennett received the seed from a friend in Monmouthshire, who he conjectures received it from Bristol, so that it is probably a recent importation. (*Country Times*, Feb. 8th, and *Cor.* with Mr. Bennett.)

5131. *There are other varieties*, as Church's oat, the Angus oat, the dun oat, &c., but they are either too local or obsolete to require particular notice. In the oat, as in other plants extensively cultivated, new varieties will always be taking the place of old ones.

5132. *To procure new varieties* adopt the mode by selection, by which, as it appears above, the potato and red oat were brought forward; or proceed systematically by cross impregnation, as directed for raising new varieties of wheat. Degeneracy, Brown

observes, has taken place to a certain extent in the potato oat; but it is presumed that the consequences might be removed with ease, were first principles returned to. To make a selection of the strongest ears, which carried the purest grain, is not a difficult business; and were this selection attended to by half a dozen farmers in a district, it is obvious, that the breed, or variety, might be preserved pure and uncontaminated. If slovenly farmers were not provided with good seed, it would be their own fault; since, if they would not take the trouble to select and breed for their own use, they might always be provided by those who were either better qualified for making the selection, or were more attentive to the interests of agriculture. (*Brown.*) Some of the Northumberland farmers have been at the pains to select the grains, instead of the ears, after being threshed. The best seeds are picked out by hand by women.

5133. *In choosing a sort* from among the varieties described, the potato and Poland are the best for lowlands, and the red oat for uplands and late climates in a state of good cultivation. For inferior soils the white or common oat, and for the poorest of all the black oat, may be adopted.

5134. *The soil* for oats may be any kind whatever, from the stiffest clays to moss or bog, provided it be laid sufficiently dry. The most tenacious clays, and meagre gravels and sands, where scarcely any useful seed-bearing plant, except buck-wheat, could be grown, will produce a crop of oats if ploughed at a proper season, and the seed judiciously sown and covered.

5135. *The preparation of the soil* for oats is less than for any other grain. It is almost always the first crop on newly broke-up lands; and as it prospers best on a soil not too finely pulverised, it is commonly sown on one earth. In regular rotations, oats are chiefly sown after grass; sometimes upon land not rich enough for wheat, that had been previously summer-fallowed, or had carried turnips; after barley, and rarely after wheat, unless cross-cropping, from particular circumstances, becomes a necessary evil. One ploughing is generally given to the grass-lands, usually in the month of January, so that the benefit of frost may be gained, and the land sufficiently mellowed for receiving the harrow. In some cases a spring furrow is given when oats succeed wheat or barley, especially when grass-seeds are to accompany the crop. The best oats, both in quantity and quality, are always those which succeed grass; indeed, no kind of grain seems better qualified by nature for foraging upon grass-land than oats; as a full crop is usually obtained in the first instance, and the land left in good order for succeeding ones. (*Tr. on Rural Affairs.*)

5136. *The climate* for oats should be cool and moist; when dry and warm, the panicles are so dried and contracted that they cease to convey sufficient nourishment to the ears, which thus never become plump, but thick husked, long awned, and unproductive in meal. This is very often the case with the oats in Scotland in a very dry year, and very common in the south of England in most years.

5137. *The season of sowing oats* is from the last week in February to the end of April. About the middle of March is preferred by the best farmers. No preparation is ever given to the seed; but it should be plump, fresh, and free from the seeds of weeds. Common oats sown in autumn are generally killed during winter, the plant being in this respect more tender than wheat, rye, or barley bigg. In some parts of Ireland, and especially in the county of Dublin, the Friezland oat is sown in autumn; and the advantage is they ripen nearly a month sooner than those sown in spring, an important object in a moist climate.

5138. *The quantity of seed*, where oats are sown broad-cast, is usually from four to six bushels to the acre. Land sown with potato oats requires less seed, in point of measure, than when any of the other sorts is used: first, because this variety tillers better than any other; and next, because having no awn, a greater number of grains are contained in a bushel.

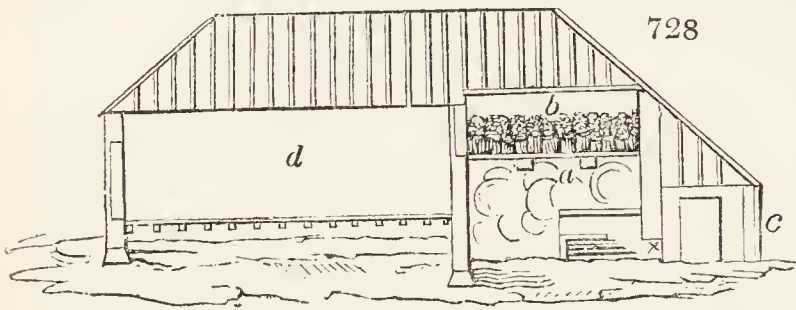
5139. *The mode of sowing oats* is almost universally broad-cast; but where they are sown after turnips, or on other well pulverised soils, some adopt the row culture.

5140. *The after-culture* depends on the mode of sowing, but seldom consists of more than weeding before the flower-stalks begin to shoot up.

5141. *In harvesting oats* in England, they are generally cut down with the scythe, and carried loose to the barn or stack; but in the northern districts, and where threshing machines are used, whether mown, or, what is most usual, reaped with the sickle, they are tied in sheaves to facilitate the process of threshing. Oats are ready for the scythe or sickle when the grain becomes hard, and the straw yellowish. They should generally be cut before they are dead ripe, to prevent the shedding of the grain, and to increase the value of the straw as fodder. They rarely get much damage when under the harvest process, except from high winds, or from shedding, when opened out after being thoroughly wetted. The early varieties are much more liable to these losses than the late ones; because the grain parts more easily from the straw,—an evil to which the best of grain is at all times subject. Early oats, however, may be cut a little before

dead ripe, which, to a certain extent, lessens the danger to which they are exposed from high winds; and if the sheaves are made small, the danger from shedding after rains is considerably lessened, because they are thus sooner ready for the stack. Under every management, however, a greater quantity of early oats will be lost during the harvest process than of the late ones; because the latter adhere firmly to the straw, and consequently do not drop so easily as the former. (*Brown.*) In harvesting oats in wet seasons, the practice of gaiting the sheaves (3176.) is generally adopted. In Sweden, in most seasons, the oat crop is dried on frames or poles (704.); and in Russia, not only oats, but barley and rye, are kiln-dried in the straw.

5142. *Kiln-drying oats and other corns in the straw* has been found necessary, and is very generally practised through the north of Russia, Livonia, Courland, and Lithuania, being the last operation of harvest for preserving all kinds of corns, peas, beans, and buck-wheat. They are dried in the fields as much as can be; but, when brought home, they are kiln-dried, and are then ready to be either threshed out immediately, or put up in barns, without any danger of either corn or straw becoming musty or rotting. The common practice of the boors is, during winter, to thresh out by degrees, as in this country, their oats and barley, in order to have straw fresh for their cattle, such straw being their only provender. The process of kiln-drying by no means prevents the germination of the grain when used for seed, while it not only preserves the grain and straw but improves their taste and salubrity. It enables Russia to export large quantities of rye and wheat, with less risk of damage to the grain than is incurred by other nations of the north of Europe.



5143. *The kiln* (*fig. 728.*) in general and established use throughout Russia, for the purpose of drying corn in the straw, is heated commonly by fires of wood. It is a simple and cheaply erected structure, the walls eight feet high, and fifteen feet square within. At this height there are two strong cross-beams (*a*), to support the small timbers, laid over them as ribs. The corn stands in sheaves above these ribs (*b*), closely set up, the band ends of the sheaves down,

and the corn or grain ends up: the walls then rise above the ribs about five or six feet more, the kiln being closed by a simple ceiling of cross joists at this height, covered with thin turf. Any cheap and ordinary roof answers to cover the whole. The fire-place is constructed so as to throw back the ascending spark; a small porch (*c*), directly opposite to the fire-place, prevents violent blasts of wind, and covers from rain the fuel and the attendant. About 300 sheaves (twenty-five stooks) of corn are dried at one time. It is put on in the evening, and left on the kiln through the night, after the wood has been burned into charcoal, and the door above the fire-place closed. At one end of the kiln there is frequently an open shed or barn (*d*), for convenience in bringing corn to, or taking it from, the kiln.

5144. *The produce of oats* is generally considered greater and of better quality in the northern than in the southern counties; and the reasons are obviously that, in the former, more attention is paid to their culture, and the climate is more favourable for the maturation of the grain. Ten quarters an acre is reckoned a good crop in the north, but the produce is often twelve and thirteen quarters, and the straw from two to three and a half loads per acre.

5145. *The produce of oats in meal amounts to 8 lbs. for 14 lbs. of corn.* Sir H. Davy found 100 parts of oats afford 59 parts of starch, six of gluten, and two of saccharine matter.

5146. *The use of oats* in the north, in Ireland, and in some parts of Yorkshire and Derbyshire, is partly for meal and partly for horse-food. In the south it is almost entirely for horse-food, poultry, and groats for gruel. It is occasionally malted and used in distillation. The fine powder which is produced by husking the corn, or making grist, forms the sowens of the Scotch (the flummery of the Irish), an agreeable light and wholesome supper dish.

5147. *The diseases of the oat* are few. Sometimes it is found attacked by the smut; but the more common injury sustained by oats is from wire-worms, or larvæ of insects which generally abound in lands newly broken-up from turf. One of the most certain modes of avoiding these is, by not ploughing the ground, especially if old turf, till immediately before sowing. By this means the insect is turned down, and before it can work its way to the surface (if ever it does) the corn is beyond its reach. In this way gardeners destroy and retard the progress of the gooseberry caterpillar by digging under the bushes; for it is found that the eggs and larvæ of insects, like seeds and bulbs, when buried too deep in the ground, have their progress retarded, or their vital principle destroyed. In late harvests, more especially in the northern parts of the island, the oat is liable to be frosted and rendered unfit for seed before being harvested. There is no remedy for such an accident; but we have shown (4997.) how it may be detected, so as not to disappoint the sower of such grain. (*Encyc. of Gard.* 4663.)

SECT. V. *Cereal Grasses cultivated in Europe, some of which might be tried in Britain.*

5148. *The cereal grasses which the climate of Britain does not readily admit of cultivating,* are the maize, Canary corn, millet, and rice.

SUBSECT. 1. *Maize, or Indian Corn.* — *Zèa Mays* L.; *Monœcia Triándria* L., and *Gramíneæ* J. *Le Mais, or Blé de Turquie, Fr.*; *der Mays, Germ.*; *Gran turco, Ital.*; and *Maiz, Span.*

5149. *The maize* is the noblest looking of the cereal grasses. It is considered to be a native of South America, to have been cultivated in Mexico and Peru from time immemorial, to have been introduced to Europe about the beginning of the 16th century, and to England in 1562. It is at present cultivated in almost every part of the universe where the summer temperature equals or exceeds that common to latitude 45°, and even to 48°. In France, in Arthur Young's time (1787), the principal country of the maize was to the south of a line drawn from Bordeaux to Strasbourg, in lat. 48° 35'; but it is at present cultivated as far north as Nancy, which is in latitude 49°, — a fact which shows that this grain is taking a wider range of temperature. "It flourishes on the western continent from about the 40th degree of southern to higher than the 45th degree of northern latitude. It is extensively produced in Africa and in Asia; on all the shores of the Mediterranean, in Spain, Italy, part of France, and the countries of the Levant, it is the food in most common use. Of the cultivated Cereàlia, indeed, it is that which, next to the rice, supplies food to the greatest number of the human race; and it may be held to be the most valuable gift of the new world to the old." (*Quar. Jour. Ag.* i. 485.) In England it has been cultivated for upwards of a century, in nursery gardens in the neighbourhood of the metropolis, for the curious purpose of supplying seedsmen in all parts of the island with ears of the corn to ornament their shop windows: it has also been grown in the kitchen gardens of some individuals who have lived in America, for the purpose of using the ears in a green state: it has been tried also in the fields, and more especially in 1828 and 1829, in consequence of the public attention being called to the subject by Mr. Cobbett.

5150. *As a bread corn* it cannot be greatly commended; the ear is highly productive of flour, but that flour is deficient in gluten, and cannot be made into bread without a large admixture of the flour of wheat. For fattening cattle and poultry of every description it is found excellent, and its culture in Europe can only be recommended with a view to this object.

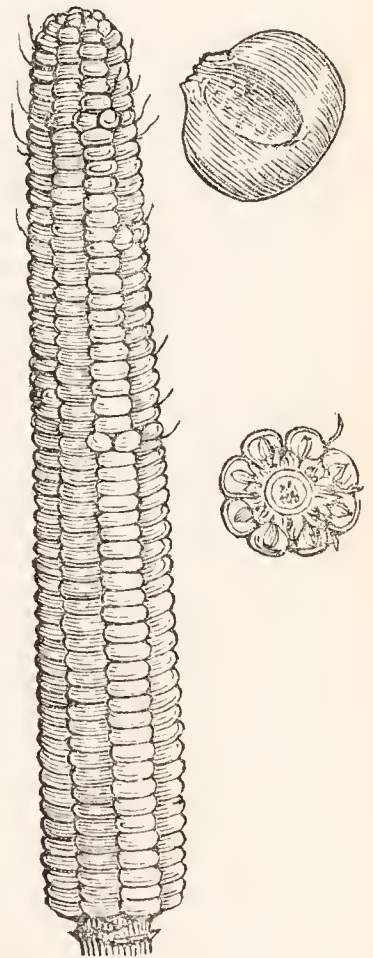
5151. *Varieties.* Like other plants which have been long in cultivation in various countries, there are

numerous varieties of the maize. According to Lagasca, there are 130 varieties known in Spain. That grown in the warmer parts of America is called the large yellow, *Maïs jaune, grand, Fr.* (*fig. 729.*) There is a large red, which differs from the other only in the colour of the skin of the grain: both have very large and handsome ears (*fig. 730.*) There is the large yellow flint, the large white flint, the sweet corn, the pearl corn, the maize quarantine, ripening in forty days, and the Egyptian or chicken corn, *Maïs à poulet, le plus petit et le plus précoc, of Vilmorin's catalogue.* There is also what is called Cobbett's corn (*fig. 731.*), which seems to be nothing more than the *Maïs quarantaine.* The two last varieties have small handsome ears (*figs. 732. and 733.*), and can hardly be distinguished from each other. All these sorts have been tried together in the same field, and the Egyptian or chicken corn found decidedly the most early, and the *Maïs quarantaine, forty days' corn, or Cobbett's corn, next.* These two sorts, therefore, alone deserve culture in this country. The *Zèa Curagùà, the Valparaiso corn,* is a distinct species, to which a sort of religious reputation is attached, on account of the grains, when roasted, splitting regularly into the form of a cross.

729



730

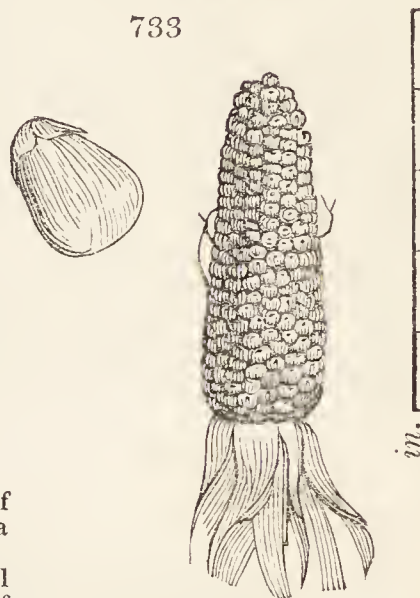
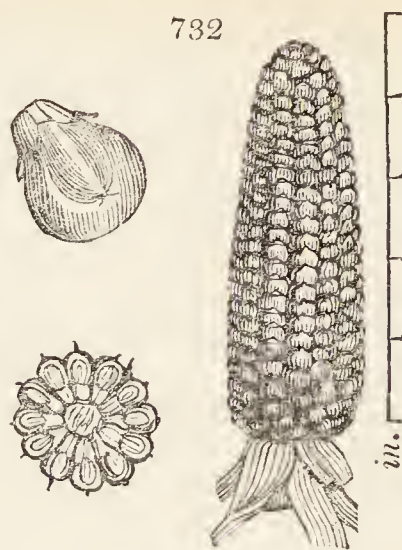


5152. *Soil and climate.* A rich loamy soil, which will grow good wheat, tobacco, or potatoes, will



grow the strongest plants; but the corn on such plants will be much less likely to ripen than that produced on a dry, warm, sandy, or calcareous soil. It must be obvious, from what has been before advanced, that there are few, if any, parts of Britain north of York where the climate will be at all suitable to this grain.

5153. *Culture.* This grain is almost every where sown or planted in rows, placed at such a width as to admit of horse-hoeing the intervals. When this is practised, as the grain contains very little gluten, the crop may be considered as a good preparation for wheat in very rich soils; it accordingly precedes that grain in the best cultivated parts of North America; but we question if it would be advisable to follow this practice in old cultivated countries, notwithstanding that maize and wheat differ so much in regard to gluten.



5154. *The preparation of the soil* may be the same as for a crop of barley, according to Cobbett; but we should say, the same as for a crop of turnips on the raised ridglet or Northumberland system.

5155. *Sowing.* The quantity of seed required is from one bushel to three bushels per acre. In Long Island, near New York, the time of sowing is from the 10th to the 20th of May; in France, from the 15th of April to the 15th of May; in England, from the 15th of April to the 20th of the same month, according to Cobbett; but we have no doubt that, in situations where the earliest varieties will succeed at all, they will succeed if sown a week or ten days later. The grain will retain its vegetative powers for at least six years. (*Gard. Mag.* vol. vi. p. 444.)

5156. *The mode of planting the corn* in America is by drawing shallow drills, commonly three or four feet distant from each other, and dropping the seeds by hand, at eight inches apart, in the row. This distance is evidently too great for the early dwarf varieties; and we think three furrows, or twenty-seven inches, the ordinary width between rows of potatoes and turnips, much more suitable. We should decidedly prefer dibbling, either by hand or by a machine, to opening a drill and depositing the seeds. In several places in France the seeds are sown broad-cast and harrowed in, and the after-culture consists in hand-hoeing between them. By sowing on raised drills the horse-hoeing system may be applied as effectually as in the culture of turnips or beans. Cobbett recommends intervals between the rows of five feet, and the plants at six inches' distance in the row, with a view to admit a superior degree of tillage between, with a view to the wheat crop. He also describes the mode of planting in hills. The situations of these hills having been marked out by a light plough, or even by trailing a log of wood, first in lines five feet apart in one direction, and next in lines in the opposite direction at right angles to the former, so as to leave the surface in squares, the planter takes a hoe, and at every intersection of the lines makes a little hole about an inch and a half deep, and about six inches in diameter, and in this hole five or six seeds are regularly distributed, and covered over with fine earth to the depth of an inch and a half. It is evident that by this mode of planting the ground may be very thoroughly worked during the growth of the crop; but it is evident also that it could only be adopted in this country on dry soils, that would admit of being kept during spring and autumn without water furrows.

5157. *Transplanting maize* may be adopted on a small scale, the advantages of which are that the ground may be better prepared before planting, and that the crop may be made to come in in succession with one which has stood in the ground during winter. The plants may be raised in a hotbed, and protected by mats; or they may be raised in a warm border of dry rich soil, covered with straw or straw mats during nights till the common ash, the mulberry, or the walnut are in leaf; they may then be carefully raised and transferred to the field, with a small portion of earth attached to each, planted with a spade or trowel, and watered unless it should happen to rain.

5158. *The after culture*, according to Cobbett, commences with scaring away birds and destroying slugs, and afterwards in removing weeds and stirring the soil. The plants will be one foot and a half high in July; and no one at that season, Cobbett says, need be afraid of tearing about the roots with the plough as much as he will. One thing is certain, he says, that if the ground between the rows be not ploughed at all, there will be no crop at all. The last process with the plough is earthing up, which is said to be useful for two purposes: first, to keep the plants steady, in case of very rough winds; and, second, to give it a fresh stock of roots. "Leave a corn-plant with nothing but flat hoeing, and without earthing up, and you will see all around its roots coming out just above the ground, and going immediately down into the ground."

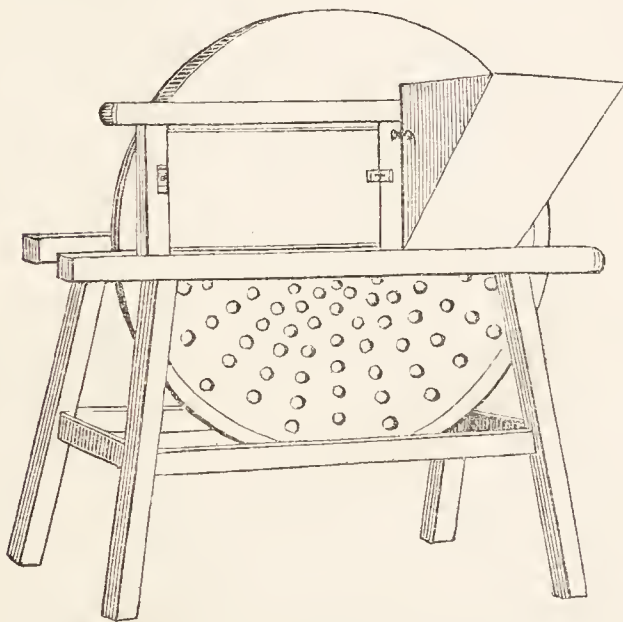
5159. *Topping the plants.* The male and female blossoms being on different parts of the plant, have given rise to this operation. The male flowers are always situated on the top or summit of the stem, and the female flowers below, near the bottom. "The flowers at the top having performed their function, and deposited the pollen on the stigma beneath, become no longer necessary to the plant; and they, accordingly, with all the elevated part of the stem which supports them, may be wholly removed. This process is termed topping by the Americans, and is delayed until the blades or leaves may be also stripped off

without injury. The period for performing this is denoted by the state of forwardness of the vegetation. 'The time for topping is, when you, upon stripping the husks, open a little at the tops of the ears, find the grains of the corn to be hard, — not hard enough to grind, nor dry, — but hard enough to resist the strong pressure of the thumb nail. A second criterion is, all the farina having completely quitted the *tassel*, and the tassel being completely dead and dry. A third is, the perfect deadness of the ends of the silk; where, instead of the bright green that appeared before, hanging gracefully down, like the beard of an extraordinarily cunning and blaspheming Jew, you will perceive it to be a little contemptible bunch of withered-up and brown-looking stuff. When all these signs appear, the *top* and the *blades* have performed their office, and the sooner they are taken away the better; because, after this, they do no good, and only serve to retard the ripening of the ears by the exclusion which they cause to the sun and the wind.' The tops and leaves being removed, they are laid in bunches in the intervals, suffered to dry, and then carried away and stacked. This part of the produce, we are told, is now a precious deposit for the winter: 'it is liable to no inconvenience to which hay is not liable; and weight for weight, and weather for weather, an acre of corn tops and blades will give more nutriment to cattle.' They are reserved by the American farmers as food for their horses and oxen in spring; they are given to race horses and other delicate and highly prized animals. They are cut into chaff, and then mixed with barley and rye. Mr. Cobbett has stated this part of the produce to be more valuable than a crop of hay; but he has not given us data, either as regards the weight of the crop, or the quantity of the animals it will feed, to enable us to judge of the correctness of his opinion. In France and southern Europe, these parts of the plant are, in like manner, used for fodder; but we are not aware that they are held in any thing like such high estimation as a crop of hay is with us." (*Treatise on Cobbett's Corn*, and *Quar. Journ. Agr.* vol. i. p. 502.)

5160. *Harvesting.* The season of harvesting is generally October and November. In America, the ears are slipped or broken from the stem by the hand, and are carried directly to the barn-floor to undergo the process of husking. The huskers, who are generally women and children, are seated around or alongside of a large heap of ears; they have baskets placed before them; they strip off the husks, fling them behind them, and throw the ears into a basket. These baskets as filled, are carried to the granary, or corn-crib, as it is called in America. It may be two feet wide at the bottom, five feet high up the sides to the eaves, and five feet across at the top. It is open or grated at the bottom, with spars at the sides, has a weather-tight roof, and is raised from the ground by posts surrounded with tin as a protection against rats and mice. The husks form an excellent material for stuffing mattresses, and are used for this purpose in America and on the continent of Europe. The now almost leafless stalks which remain in the fields in America are frequently burnt, but on the continent are used as litter for cattle running loose in the farmyard. The ears remain in the granary till they are wanted for shelling, or separating the grains from the receptacle. On the continent the ears are cut or broken from the stems as in America, and on a large scale are preserved in small open granaries, such as have been described; but more frequently they are hung up unhusked under the projecting eaves of all manner of buildings, and remain there till wanted for husking and shelling.

5161. *Shelling or threshing.* This, Cobbett tells us, is done in America by scraping or rasping the ears

734



upon a piece of iron, fixed across a tub, into which the grains fall. The iron is commonly a bayonet. In this country there are machines of different kinds (*fig. 734.* and § 2550.), which perform the operation of shelling with great rapidity; but whoever has a threshing machine might, by setting the rollers and drum somewhat wider than usual, dispense with manual labour, both in the operations of husking and shelling; and indeed we see no reason why the crop should not be harvested like a crop of drilled beans, with Gladstone's bean reaper (2740.), and sheaved, shocked, stacked, and threshed, like any other grain.

5162. *Produce.* In America and Australia, the produce in corn is from fifty to seventy bushels to the acre; on the continent it is generally between fifty and sixty; and the produce in this country, as it appears by some experiments recorded in the *Gard. Mag.* vol. vi. p. 60 to 67., would probably be similar, notwithstanding the circumstance of Mr. Cobbett, Mr. Moore of Sandy, in Bedfordshire, and some others, having raised on small spots at the rate of 100 bushels per acre and upwards. The produce in straw in America and warm countries, where the tallest

sorts can be grown, is considerable; but in this country, where only the dwarfest sorts could be cultivated with success, it would not equal that of a crop of oats or barley.

5163. *The application* of this crop, according to Cobbett, is various and important: "pig-feeding, sheep-feeding, oxen and cow-feeding, poultry-feeding, horse-feeding, and man-feeding;" to which we may add fish, carp being fed with maize in France. For "man-feeding" it is only made use of in America till the farmer can afford to grow wheat; and on the continent it is only used as a bread corn by the poorest of the people. The wretched inhabitants of the southern part of the Neapolitan territory live chiefly on maize; as those of some mountainous districts in the north of Italy live on bread made from chestnuts, or buck-wheat. The most important purpose to which the corn uncrushed can be applied in Europe, appears to us to be the feeding of poultry. All the fat geese noted for their large livers in the north-west of France and south-east of Germany are fed with maize, the grains unbroken; and the smaller poultry in these countries are also chiefly fed with this corn, broken or ground into meal.

5164 *Turkey feeding*, according to Cobbett, is one of the many purposes to which the corn may be applied in this country:—"We killed, last spring, one single pullet, not of a large breed, out of which we took loose fat weighing *three quarters of a pound*. We fattened most perfectly and finely ten turkeys in the same manner; and as to geese and ducks, which fat still easier than either of the former, they will get fat in this manner in a short space of time. If you wish to have fresh eggs in winter, you need resort to no steeping of barley in beer or in wine, or to giving the hens hempseed, or the seed of nettles, as the French do; nor to make such a fuss about keeping the hens warm: give them plenty of corn, *whole*, and you will have fresh eggs all the winter long. To the very little chickens, or very young turkeys, you must give some in a *cracked* state; but they very soon take it down whole; and, large as it is, the sparrows will eat it as fast as the fowls; and, if you be much infested with them, and do not wish to have a numerous and early breed of them next spring, you must feed the poultry close to the door, or stand by them during the meal, which, however, is conveniently short; for the grain is so large that their craws are filled in a minute. It is very well known that,

in order to have a *fat turkey*, or even a really fat fowl, we are compelled to resort to cramming. If the farmer's wife have a dozen of these, there she sits (for she can trust nobody else to do it), with a leathern apron before her, or rather upon her, with balls of barley-meal rolled into an oblong form, and with a bowl of warm milk, or with some greasy water, taking one turkey out of the coop at a time upon her lap, forcing its mouth open with her left hand, putting in the balls with her right, and stroking with her fingers the outside of the neck to make them descend into the craw, every now and then pouring down a spoonful of the warm liquid, upon the principle that good victuals deserve good drink. There she sits, if she has two dozen of these animals to cram, two good hours at least. Sometimes they reject the food, and flutter about, and splash the woman with the contents of the bowl. It is always a disagreeable, troublesome, and nasty job; it takes up a great deal of time; and yet these things cannot be made sufficiently fat without this operation, in which, I dare say, 20,000 women are at this very moment (eight o'clock in the morning) engaged, in the counties of Norfolk and Suffolk. If all these women could be brought together, and were to hear me say

and prove, that I could save them all this trouble, they would say, 'God bless you, Sir; you are the best friend (the inventor of tea and sugar excepted) that ever administered to the comfort of womankind.' Well, then, this I do for them now; let their husbands raise some Cobbett's corn, the leathern aprons may be converted into spatterdashes for them, the warm milk or greasy water may be given to young pigs, the bowl may be

converted into a porringer for a boy to eat porridge out of, the coops, well broken up by the pole of the axe, may go to light the fire, and the four hours saved morning and evening may be employed in spinning and preparing the stuff to make shirts and shifts, and sheets, or, which makes less noise, in knitting stockings for the whole family." (*Quar. Jour. Agr.* vol. i. p. 507.)

5165. *In common with other grain*, maize may be fermented, so as to produce beer; or distilled from, so as to produce spirits; the straw containing a good deal of saccharine matter that also might be extracted.

5166. *The green ears of maize* are applied to various purposes. In the neighbourhood of Paris, before the male blossom has expanded, the female is gathered and pickled, in the manner of cucumbers; and this is practised to some extent by the French and Germans. When the grain has arrived at its milky state, the ears are then gathered for the purpose of boiling or roasting. In America they are roasted on or before hot embers, and eaten with salt and butter. Boiled, they are not quite so delicate; but are still very good, especially if boiled with fat pork. The ears are generally fit for these purposes during the month of September, and a large field may afford soft ears for six weeks.

5167. *The meal of maize*, besides being given to the smaller poultry, is also used for fattening swine, old sheep which have lost part of their teeth, and for feeding old horses which cannot grind the ears whole. Of a finer quality it is given to negroes, and eaten by various persons in America, in the form of porridge, puddings, and cakes. In this country, the Rev. Henry Berry of Pensham House, Worcestershire, has found maize meal, purchased from Liverpool, superior to oatmeal in maintaining the condition of his hounds. (*Country Times*, March 22d, 1830.) The meal of maize, made into paste, and fried with fat bacon, is the ordinary food of the peasants of great part of the Brabant. It serves them likewise for fattening their fowl, of which they feed great quantities for the markets of the rest of Brabant and of Holland. (*Comm. Board of Agr.*)

5168. *Diseases and enemies.* The *Phalæna forficàlis Lin.* is said to deposit its eggs in the stems of the plant, and the larvæ which these produce eat out its interior, so as to weaken the strength of the spikes. There are also three species of smut, *Urèdo Pers.*, which are parasitic on the maize, and destroy the grain by reducing it to a black powder. One species is peculiar to the flower, attacks it before it arrives at maturity, and finishes by leaving it in a state of black powder. The French writers recommend washing and pickling in the same manner as for wheat. The stalks and leaves, being very sweet, are greedily sought for by field rats, mice, and other enemies. In the granary, the maize, like other grains, is attacked by different species of weevil, of which this insect produces serious injury in America, but is not very likely to be troublesome in this country.

SUBJECT. 2. *Canary Corn.* — *Phálaris canariénsis L.*; *Triándria Digýnia L.*, and *Gramíneæ J.* *Alpiste de Canaire*, Fr.; *Kanariengras*, Ger.; *Falari*, Ital.; and *Alpiste*, Span. (*fig.* 735.)

5169. *The Canary grass* is an annual, with a culm from a foot to eighteen inches in height, and lively green leaves almost half an inch in width. The seeds are thickly set in a subovate panicle or spike. It is a native of the Canary Islands; but now naturalised in several parts of England, and on the Continent. It flowers from June to

August, and ripens its seeds from September to October. It has long been cultivated in the Isle of Thanet, and a few other places in Kent and Essex: it is there considered an uncertain crop, both on account of the seasons, it being the latest of all the grasses in ripening its seeds, and of the fluctuation of prices.

5170. *The culture* of the Canary grass consists in pulverising a loamy soil in good heart, or manuring it if worn out; though every judicious farmer tries to avoid giving manure to a corn crop unless after a naked fallow. The seeds are sown in rows at about a foot apart, generally by the ribbing process: the season the month of February, and the quantity of seed four or five gallons per acre. The after-culture consists in repeated hoeings and weedings.

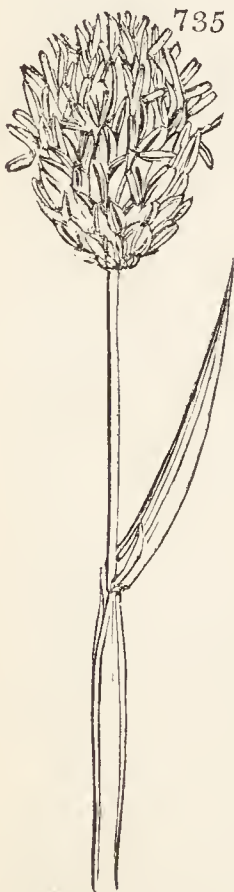
5171. *The reaping process* seldom commences before the end of September. The culm being leafy, and the seed difficult to separate from the chaff, it requires to lie in handfuls for a week or more, and to remain more than that time in the field after being tied up in sheaves. In the Isle of Thanet it is cut with a hook, provincially called a *twibil* and a *hink*; by which it is laid in lumps, or wads, of about a sheaf each. The seed clings remarkably to the husk; and, in order to detach it, the crop is left a long time on the ground, to receive moisture sufficient to loosen the enveloping chaff, otherwise it would be hardly possible to thresh out the seed. The wads are turned from time to time, to have the full benefit of the rains and sun.

5172. *The common produce* of Canary grass is from thirty to thirty-four bushels per acre; but under the best management in the Isle of Thanet it is often fifty bushels per acre.

5173. *The use* of the seed is chiefly as food for Canary and other cage and aviary birds. The chaff is superior to that of every other culmiferous plant for horse-food, and the straw, though short, is also very nutritive.

SUBJECT. 3. *The Millets.* — *Pánicum* and *Sórghum L.*; *Triándria Digýnia* and *Polygámia Monæcia L.* and *Gramíneæ J.* *Panis* and *Sorgho*, Fr.; *Panick* and *Hirse*, Ger.; *Panico* and *Sageno* or *Sorgo*, Ital.; and *Alcandia*, Span.

5174. *Of the millet* there are three distinct genera: the Polish millet (*Digitaria*), cultivated in Poland; the common millet (*Pánicum*), or panic grass, cultivated in Germany,



and sometimes in this country; and the great or Indian millet (*Hólcus*), cultivated in India, Italy, and America.

5175. Of the common millet there are three species: *Setària germánica* (fig. 736. *a*), a native of the south of Europe; the *P. miliàceum* (*b*), a native of the East Indies; and the *Setària itálica* (*c*), also of Indian origin.



5176. The German millet (*Moha de Hongrie*, Fr.; *S. germánica*, *a*) rises with a jointed reed-like stalk, about three feet high, and about the size of the common reed, with a leaf at each joint a foot and a half long, and about an inch broad at the base where broadest, ending in an acute point, rough to the touch, embracing the stalk at the base, and turning downwards about half the length. The stalks are terminated by compact spikes, about the thickness of a man's finger at bottom, growing taper towards the top, eight or nine inches long, and closely set with small roundish grain. It is annual, and perishes soon after the seeds are ripe. There are three varieties of it, the yellow, white, and purple grained. It was formerly cultivated for bread in some of the northern countries.

5177. The common or cultivated millet (*Millet commun*, Fr.; *Panicum miliaceum*, *b*) rises with a reed-like channelled stalk, from three to four feet high; at every joint there is one reed-like leaf, joined on

the top of the sheath, which embraces and covers that joint of the stalk below the leaf, and is clothed with soft hairs; the leaf has none, but has several small longitudinal furrows running parallel to the midrib. The stalk is terminated by a large loose panicle hanging on one side. Of this species there are two varieties, the brown and the yellow; the latter of which was formerly in cultivation, and is now sometimes sown for feeding poultry, and as a substitute for rice.

5178. The Italian millet (*Panis d'Italie*; *Millet à grappe*, Fr.; *Setària itálica*, *c*) rises with a reed-like stalk, nearly four feet high, and much thicker than that of the preceding; the leaves are also broader. The spikes are a foot long, and twice the thickness of those of the common millet, but not so compact, being composed of several roundish clustered spikes; the grain is also larger. There are two or three varieties of this, differing only in the colour of the grain. It is frequently cultivated in Italy (whence its trivial name), and other warm countries. It is a native of both Indies, and of Cochin China.

5179. The Polish millet, or manna grass of the Germans (*Digitaria sanguinalis*, formerly *Panicum sanguinalis*, fig. 737.), is a low decumbent, annual plant, seldom rising above nine inches or a foot high, with hairy leaves and slender panicles. It tillers much, and forms a close tuft, spreading and rooting at the joints. It is a native of England but not common. It grows in abundance in Poland, and is sometimes cultivated, the seeds being used like those of the other millets as a substitute for rice or sago.



5180. The great or Indian millet (*Hólcus Sórghum* L., *Sórghum vulgàre*, W. en. fig. 738. *Sorgho*, *gros millet d'Italie*, Fr.; *Sorgsamén*, Ger.; *Sagina*, Ital.; and *Melœa*, Span.) has a stem which rises five or six feet high, is strong, reedy, and like those of the maize, but smaller. The leaves are long and broad, having a deep furrow through the centre, where the midrib is depressed in the upper surface, and is very prominent below. The leaves are two feet and a half long, and two inches broad in the middle, embracing the stalks with their base. The flowers come out in large panicles at the top of the stalks, resembling, at first appearance, the male spikes of the Turkey wheat; these are succeeded by large roundish seeds, which are wrapped round with the chaff. This grain is a native of India, where it is much used to feed poultry, and is frequently sent to Europe for the same purpose. It is much cultivated in Arabia, and most parts of Asia Minor; and has been introduced into Italy, Spain, Switzerland, and some parts of Germany, also into China, Cochin China, and the West Indies, where it grows commonly five or six feet high, or more, and being esteemed a hearty food for labourers, is called negro Guinea corn. Its long awns or bristles defend it from the birds. In England, the autumns are seldom dry and warm enough to ripen the seed well in the field. In Arabia it is called *dora* or *durra*; the flour is very white, and they make good bread of it, or rather cakes, about two inches in thickness. The bread which they make of it in some parts of Italy is dark and coarse. In Tuscany it is used chiefly for feeding poultry and pigeons; sometimes for swine, kine, and horses. Cæsarpinus says, that cattle fed on the green herb are apt to swell and die, but thrive on it when dried. They make brushes and brooms of its stalks in Italy, which Ray observed in the shops at Venice, and which are sent to this country. Of this species there are two distinct varieties; one distinguished by black, and the other by red, husked seeds, besides subvarieties.

5181. The only sorts of millet which can be cultivated with success in this country are the German, cultivated, and the Polish sorts. According to Professor Thaer, the cultivated is to be preferred, as having the largest grain.

5182. The soil for the millet should be warm, sandy, rich, and well pulverised to a good depth. The seed is sown in May, very thin, and not deeply covered. In the course of its growth no plant, Professor Thaer observes, is more improved by stirring the soil, after which it grows astonishingly fast, and smothers all weeds.

5183. In harvesting the millet, great care is requisite not to shed the seed; and as it ripens rather unequally, it would be an advantage to cut off the spikes as they ripen, as

in reaping maize. No grain is easier to thresh, or to free from its husk by the mill. It is used instead of rice, and in Germany bears about the same price. It produces a great bulk of straw, which is much esteemed as fodder.

5184. *The great Indian millet* will grow in this country to the height of five or six feet; but will not ripen its seeds, or even flower, if the season is not dry and warm. If its culture is attempted, it should be raised in a hotbed and transplanted.

SUBJECT. 4. *Rice, and some other Cereal Grámina.*

5185. *The rice* (*Oryza sativa*, fig. 739.) has been tried in this country, and, if sown very early, would probably ripen its seeds. The hill variety, which does not require watering, would probably succeed best. But there is no inducement to cultivate this and other grains or seeds when they can be imported at so low a rate. We merely introduce them to record the resources of British agriculture in case of necessity.



5186. *The Zizània aquática* (fig. 740.) might be cultivated on the margin of ponds for its seeds, which much resemble those of Polish millet. It is exceedingly prolific, grows in great luxuriance, and produces abundance of bland farinaceous seeds, in all the shallow streams of the dreary wilderness in north-west America, between the Canadian lakes and the hilly range which divides Canada from the country on the Northern Pacific Ocean. Its seeds contribute essentially to the support of the wandering tribes of Indians, and feed immense flocks of wild swans, geese, and other water fowl, which resort there for the purpose of breeding. Productive as is this excellent plant, and habituated to an ungenial climate, and to situations which refuse all culture, it is



surprising, says Pinkerton (*Geog.* vol. iii. p. 330.), that the European settlers in the more northern parts of America have as yet taken no pains to cultivate and improve a vegetable production which seems intended by nature to become, at some future period, the bread corn of the north.

5187. *The Glycèria fluitans* resembles the *Zizània*, and the seeds are used in Germany like those of Polish millet. Various species of *Pánicum*, *Hórdeum*, and *Bròmus* afford tolerable supplies of edible seeds.

5188. *The buck-wheat* (*Polýgonum Fagopyrum*; *Riz*, Fr.; *Reiss*, Ger.; *Riso*, Ital.; *Arroz*, Span.) is vulgarly considered as a grain; but not being a bread-corn grass, we have classed it among manufactorial plants. (Chap. VIII. Sect. IV.)

CHAP. III.

Culture of Leguminous Field-Plants, the Seeds of which are used as Food for Man or Cattle.

5189. *The seeds of the cultivated legumes* are considered to be the most nutritive of vegetable substances grown in temperate climates. They contain a large proportion of matter analogous to animal substances, having when dry the appearance of glue, and being as nourishing as gluten. To the healthy workman this substance supplies the place of animal food; and Von Thaer states, that in Germany neither sailors nor land labourers are content unless they receive a meal of legumes at least twice a week. The straw or haulm, he says, cut before it is dead ripe, is more nourishing than that of any of the cereal grasses. But leguminous plants are not only more than all others nourishing to man and animals, but even to vegetables they may be said to supply food; since they are not only known to be less exhausting to the soil than most other plants, but some of them, and more especially the lupine, have been ploughed in green as manure from the earliest times. Many scientific agriculturists consider a luxuriant crop of peas or tares as nourishing the soil by stagnating carbonic acid gas on its surface; which corresponds with the universal opinion of their being equal to a fallow, and with the value set on them in rotation, as already explained. (4939.) Two reasons may be given for the circumstance of peas and tares not exhausting the land so much as other crops: first, because they form a complete shade for the ground; and next, because they drop so many of the

leaves upon the surface. The legumes cultivated in British farming are, the pea, bean, tare, and vetch, to which might be added the lentil, kidneybean, and chick pea.

5190. *The nutritive products* of these plants are thus given by Sir H. Davy, Einhoff, and Thaer: —

Systematic Name.	English Name.	In 100 Parts.				
		Whole quantity of soluble or nutritive matter.	Mucilage or starch.	Saccharine matter, or sugar.	Gluten or albumen.	Extract, or matter rendered insoluble during evaporation.
<i>Pisum sativum</i> -	Dry peas -	574	501	22	35	16
<i>Vicia Faba</i> -	Common bean -	570	426	—	103	41
<i>sativa</i> -	Tares -	65	36	—	29	—
<i>Ervum Léns</i> -	Lentils -	71	39	—	32	—
<i>Phaseolus vulgaris</i> -	Kidneybean -	89	67	—	22	—

SECT. I. *The Pea.* — *Pisum sativum* L.; *Diadélphia Decándria* L., and *Leguminòsæ* J. *Les Pois*, Fr.; *Erbse*, Ger.; *Piscello*, Ital.; and *Pesoles*, Span. (fig. 741.)

741



5191. *The pea is the most esteemed legume in field cultivation*, both for its seed and haulm. It is supposed to be a native of the south of Europe, and was cultivated by the Greeks and Romans. In this country it has been grown from time immemorial: but its culture appears to have diminished since the more general introduction of herbage, plants, and roots; and the pea, except near large towns for gathering green, and in a few places for boiling, has given way to the bean, or to a mixture of peas and beans. There are various inducements, however, to the cultivation of peas in dry warm soils near large towns. When the crop is good and gathered green, few pay better: the payment is always in cash, and comes into the pocket of the farmer in time to meet the exigencies of the hay, and sometimes even of the corn, harvest. The ground, after the peas have been removed, is readily prepared for turnips, which also pay well as a retail crop near towns; and the haulm is good fodder.

5192. *The varieties of the pea* are numerous; but they may be divided into two classes: those grown for the ripened seed, and those grown for gathering in a green state. The culture of the latter is chiefly near large towns, and may be considered as in part belonging to gardening rather than agriculture. There has lately a new sort of pea been brought into notice about Banbury in Oxfordshire. It is called the “nimble hog pea.” It appears to be a grey variety of the early frame, as it has single flowers, and is fit to cut about the end of June, notwithstanding it must not be sown earlier than the middle of April. On the excellent land about Banbury the produce is four quarters to the acre, and turnips sowed on the stubble are up and sometimes hoed out before the regular turnip crop!

5193. *The grey varieties* (*Pois gris*, *Pois-agneau*, *Bisaille*, Fr.) are, the early grey, the late grey, and the purple grey; to which some add the Marlborough grey, and horn grey.

5194. *The white varieties* (*Pois blanc*, Fr.) grown in fields are the pearl, early Charlton, golden hotspur, the common white or Suffolk, and other Suffolk varieties.

5195. *New varieties* of the pea are readily procured by selection or impregnation, of which a striking example given by Knight has been already referred to. (1632.)

5196. *In the choice of sorts*, where it is desired to grow grey peas for the sake of the seeds or corn, the early variety is to be preferred in late situations, and the late variety in early ones; but when it is intended to grow them chiefly for covering the ground and for the haulm, then the late varieties claim the preference, and especially the purple grey. Of white peas, to be grown for gathering green, the Charlton is the earliest, and the pearl or common Suffolk the most prolific. When white peas are grown for boilers, that is for splitting, the pearl and Suffolk are also the best sorts.

5197. *To have recourse to early sorts* is supposed by some to be of considerable importance in the economy of a farm, when the nature of the soil is suitable, as by such means the crops may in many cases be cut and secured while there is leisure, before the commencement of the wheat harvest; and that where the nature of the soil is dry and warm, and the pea crop of a sufficiently forward kind, it may be easy to obtain a crop of turnips from the same land in the same year, as has been suggested above. But in this view it is the best practice to put in the crops in the row method, and keep them perfectly clean by means of attentive hand and horse hoeing; as in that way the land will be in such a state of preparation for the turnips, as only to require a slight ploughing, which may be done as fast as the pea crop is removed, and the turnip seed may be drilled in as quickly as possible upon the newly turned up earth. In some particular districts a third crop is even put into the same land, the turnips being sold off in the autumn, and coleworts substituted for the purpose of greens in the following spring. This, according to Middleton, is the practice in

some places in Middlesex. But it is obviously a method of cultivation that can only be attempted on the warm and fertile kinds of turnip soil, and where the pea crops are early; on the cold heavy and wet descriptions of land it is obviously impracticable, and wholly improper.

5198. *The soil* best suited for peas is a dry calcareous sand; it should be in good tilth, not too rich nor dunged along with the crop. In Norfolk and Suffolk peas are often sown on clover leys after one furrow, or after corn crops on two furrows, one given in autumn, and the other early in spring.

5199. *The climate* required by the pea is dry and not over warm, for which reason, as the seasons in this country are very often moist and sometimes exceedingly dry and hot in June and July, the pea is one of the most uncertain of field crops.

5200. *The season of sowing* must differ considerably according to the intentions of the cultivator.

5201. *For podding early to be sold green*, they should be sown at different times, from January to the end of March, beginning with the driest and most reduced sorts of land; and with this intention in some southern counties they are sown in the autumn. *For the general crops* from February to April, as soon as the lands can be brought into proper order, is the proper season; the grey sorts being employed in the early sowings, and the white sorts in the later. Young says, that where these crops cannot be sown in February, they should always be completed in the following month. It is observed by the same writer, that, in sowing after a single furrow, the white boiling pea, of many sorts and under various names, is more tender than the greys and various kinds of hog peas; but he has many times put them into the ground in February, and, though very smart frosts followed, they received no injury. He has uniformly found, that the earlier they were sown the better. There is also a particular motive for being as early as possible; that is, to get them off in time for turnips. This is most profitable husbandry, and should never be neglected in dry and warm soils and situations. If they are sown in this month, and a right sort chosen, they will be off the land in June, so that turnips may follow at the common time of sowing that crop.

5202. *Steeping the seed in water* is sometimes practised in late sowings.

5203. *The quantity of seed* must be different in different cases and circumstances, and according to the time and manner in which the crop is put into the ground; but, in general, it may be from two and a half to three bushels, the early sowings having the largest proportion of seed. In planting every furrow slice, Young says, two bushels and a half constitute the usual proportion; but, when drilled at greater distances, six or seven pecks will answer.

5204. *The most common mode of sowing peas* is broad-cast; but the advantages of the row culture in the case of a crop so early committed to the soil must be obvious.

5205. *The best farmers* always sow peas in drills either after the plough, the seed being deposited commonly in every second or third furrow; or, if the land is in a pulverised state, by drawing drills with a machine or by ribbing. In Norfolk and Suffolk peas are generally dibbled on the back of the furrow, sometimes one and sometimes two rows on each; but dibbling in no manner appears to us so well suited for a farmer's purpose as the drill. In Kent, where immense quantities of peas are grown, both for gathering green and for selling ripe to the seedsmen, they are generally sown in rows from eighteen inches to three feet asunder, according to the kind, and well cultivated between. Peas laid a foot below the surface will vegetate; but the most approved depth is six inches in light soil, and four inches in clay soil, for which reason they ought to be sown under furrow when the ploughing is delayed till spring. Of all grain, beans excepted, they are the least in danger of being buried.

5206. *The after culture* given to peas is that of hoeing, either by hand or horse. Where the method of hand-culture prevails, it is the general custom to have recourse to two hoeings; the first when the plants are about two or three inches in height, and again just before the period in which they come into blossom. In this way the vigorous vegetation of the young crop is secured, and a fresh supply of nourishment afforded for the setting of the pods and the filling of the peas. At the latter of these operations the rows should be laid down, and the earth well placed up to them, the weeds being previously extirpated by hand labour. It has been stated, that in some parts of Kent, where this sort of crop is much grown, it is the practice, when the distance of the rows will permit, to prevent the vegetation of weeds, and forward the growth of pea crops, by occasionally horse-hoeing, and the use of the brake-harrow, the mould being laid up to the roots of the plants at the last operation by fixing a piece of wood to the harrow. This should, however, only be laid up on one side, the peas being always placed up to that which is the most fully exposed to the effects of the sun.

5207. *In harvesting the ripened pea* considerable care is requisite, both on account of the seed and haulm.

5208. *When pea crops become ripe* they wither and turn brown in the haulm or straw, and the pods begin to open. In this state they should be cut immediately, in order that the loss sustained by their shedding may be as little as possible. It is observed that in the late or general crops, after they are reaped or rather cut up by means of a hook, it is the usual practice to put them up into small heaps, termed wads, which are formed by setting small parcels against each other, in order that they may be more perfectly dried both in the seed and stem, and be kept from being injured by the moisture of the ground. But, in the early crops, the haulm is hooked up into loose open heaps, which, as soon as they are perfectly dry, are removed from the ground and put into stacks for the feeding of animals, which are said to thrive nearly as well on it as on hay. When intended for horses, the best method would seem to be that of having them cut into chaff and mixed with their other food. Young says, that forward white peas will be fit to cut early in July; if the crop is very great they must be hooked; but if small, or only middling, mowing will be sufficient. The stalks and leaves of peas being very succulent, they should be taken good care of in wet weather: the tufts, called wads or heaps, should be turned, or they will receive damage. White peas should always be perfectly dry before they are housed, or they will sell but indifferently; as the brightness and plumpness of the grain are considered more in them than in hog peas at market. The straw also, if well harvested, is very good fodder for all sorts of cattle and for sheep; but if it receives much wet, or if the heaps are not turned, it can be used only to litter the farmyard with. It is the practice in some districts to remove the haulm, as soon as it has been cut up by hooks constructed

with sharp edges for the purpose, to every fifth ridge, or even into an adjoining grass field, in order that it may be the better cured for use as cattle-food, and at the same time allow of the land being immediately prepared for the succeeding crop. When wet weather happens whilst the peas lie in wads, it occasions a considerable loss, many of them being shed in the field, and of those that remain a great part will be so considerably injured as to render the sample of little value. This inability in peas to resist a wet harvest, together with the great uncertainty throughout their growth, and the frequently inadequate return in proportion to the length of haulm, has discouraged many farmers from sowing so large a portion of this pulse as of other grain; though on light lands which are in tolerable heart, the profit, in a good year, is far from inconsiderable.

5209. *In gathering green peas for the market*, it is frequently a practice with the large cultivators of early green-pea crops in the neighbourhood of London to dispose of them, by the acre, to inferior persons, who procure the podders; but the smaller farmers, for the most part, provide this description of people themselves, who generally apply at the proper season.

5210. *The business of picking or podding the peas* is usually performed by the labourers at a fixed price for the sack of four heaped bushels. The number of these labourers is generally in the proportion of about four to the acre, the labour proceeding on the Sundays as well as other days. It is sometimes the custom to pick the crops over twice, after which the rest are suffered to stand till they become ripe, for the purpose of seed. This, however, mostly arises from the want of pickers, as it is considered a loss, from the peas being less profitable in their ripe state than when green. Besides, they are often improper for the purpose of seed, as being the worst part of the crop. It is therefore better to have them clear picked when hands can be procured. After this they are loaded into carts, and sent off at suitable times, according to the distance of the situation, so as to be delivered to the salesmen in the different markets from about three to five o'clock in the morning. In many cases in other parts, the early gatherings are, however, sent to the markets in half-bushel sieves, and are frequently disposed of at the high price of five shillings the sieve; but at the after periods they are usually conveyed in sacks of a narrow form, made for the purpose, which contain about three bushels each, which, in the more early parts of the season, often fetch twelve or fourteen shillings the sack, but afterwards mostly decline considerably; in some seasons so much as scarcely to repay the expenses. This sort of crop affords the most profit in such pea seasons as are inclined to be cool, as under such circumstances the peas are most retarded in their maturation or ripening, and of course the markets kept from being overabundantly supplied.

5211. *The threshing of peas* requires less labour than that of any other crop. Where the haulm is to be preserved entire it is best done by hand; as the threshing machine is apt to reduce it to chaff. But where the fodder of peas is to be given immediately to horses on the spot, the breaking of it is no disadvantage.

5212. *The produce of the pea* in ripened seeds is supposed by some to be from three and a half to four quarters the acre; others, however, as Donaldson, imagine the average of any two crops together not more than about twelve bushels; and that on the whole, if the value of the produce be merely attended to, it may be considered as a less profitable crop than most others. But as a means of ameliorating and improving the soil at the same time, it is esteemed of great value.

5213. *With respect to the produce in green peas* in the husk, the average of the early crops in Middlesex is supposed to be from about twenty-five to thirty sacks the acre, which, selling at from eight to eighteen shillings the sack, afford about eighteen pounds the acre. The author of *The Synopsis of Husbandry*, however, states the produce about Dartford, in the county of Kent, at about forty sacks the acre, though, he says, fifty have sometimes been gathered from that space of land.

5214. *The produce of peas in straw* is very uncertain, depending so much on the sort and the season: in general it is much more bulky than that of the cereal grasses; but may be compressed into very little room.

5215. *The produce of peas in flour* is as 3 to 2 of the bulk in grain, and husked and split for soups as 4 to 2. A thousand parts of pea flour afforded Sir H. Davy 574 parts of nutritive or soluble matter; viz. 501 of mucilage or vegetable animal matter, 22 of sugar, 35 of gluten, and 16 of extract or matter rendered insoluble during the operation.

5216. *The use of peas* for soups, puddings, and other culinary purposes, is well known.

5217. *In some places* porridge, brose, and bread are made of pea-flour, and reckoned very wholesome and substantial. In Stirlingshire it is customary to give pea or bean biscuits to horses, as a refreshment, while in the yoke. The portion of peas not consumed as human food is mostly appropriated to the fattening of hogs and other domestic animals; and, in particular instances, supplies the place of beans, as the provender of labouring horses; but care should be taken, when used in this way, that they are sufficiently dry, as, when given in the green state, they are said to produce the gripes, and other bowel complaints, in those animals. Bannister, after observing that the haulm is a very wholesome food for cattle of every kind, says, there is generally a considerable demand for peas of every denomination in the market, the uses to which they may be applied being so many and so various. The boilers, or yellow peas, always go off briskly; and the hog-peas usually sell for 6*d.* or 1*s.* per quarter more than beans. For feeding swine the pea is much better adapted than the bean, it having been demonstrated by experience, that hogs fat more kindly when fed with this grain than with beans; and, what is not easy to be accounted for, the flesh of swine which have been fed on peas, it is said, will swell in boiling, and be well tasted; whilst the flesh of the bean-fed hog will shrink in the pot, the fat will boil out, and the meat be less delicate in flavour. It has, therefore, now become a practice with those farmers who are curious in their pork, to feed their hogs on peas and barley-meal; and if they have no peas of their own growth, they rather choose to be at the expense of buying them, than suffer their hogs to eat beans. Nay, so far, says he, do some of them carry their prejudice in this particular, as to reject the grey peas for this use, as bearing too near an affinity to the bean, and therefore reserve their growths of white peas solely for hog-fattening.

5218. *In boiling split peas*, some samples, without reference to variety, fall or moulder down freely into pulp, while others continue to maintain their form. The former are called boilers. This property of boiling depends on the soil; stiff land, or sandy land, that has been limed or marled, or to which gypsum has been applied, produces peas that will not melt in boiling, no matter what the variety may be. The same effect is produced on beans, on kidneybeans in the pod, and indeed on the seeds and pods of all leguminous plants; this family having a great tendency to absorb gypsum from the soil. To counteract this fault in the boiling, it is only necessary to throw into the water a small quantity of subcarbonate of soda. (*Bull. de Sci. Agr.* Feb. 1828.)

5219. *Pea straw cut green* and dried is reckoned as nourishing as hay, and is considered excellent for sheep.

5220. *In the saving of any particular sorts of peas for seed*, they should be carefully looked over while in flower, in order to draw out all such plants as are not of the right kind; as there will always be, in every sort, some roguish plants, which, if left to mix, will cause degeneration. As many rows as may be thought sufficient to furnish the desired quantity of seed should then be marked out, and left till their pods turn brown, and begin to split, when they should immediately be gathered up, with the haulm; and if the farmer has not room to stack them till winter, they may be threshed out as soon as they are dry, and put up in sacks for use: but particular care should be taken not to let them remain too long abroad after they are ripe; as wet would rot them; and heat, after a shower of rain, makes their pods burst in such a manner that the greater part of their seeds would be lost.

5221. *The diseases of peas are few*, and chiefly the worm in the pod and the fly on the leaves and flower. They are also liable to be mildewed or blighted. None of these evils, however, are very common; and there is no known way of preventing them but by judicious culture. Late sown peas are particularly liable to be injured by the mildew and Aphis; and should either of these attack the plant before the pods are filled, they invariably fail. In 1826 almost all the crops of peas were destroyed by the A'phides, so that they were mown for the haulm only.

SECT. II. *The Bean.*—*Vicia Faba* L.; *Diadélphia Decándria* L., and *Leguminòsæ* J. *Féverole*, Fr.; *Bohn*, Ger.; *Fava*, Ital.; and *Alverjanas*, Span.

5222. *The bean is a valuable field plant*, as affording food for live stock, and in part for man. It is said to be a native of Egypt; but, like other long domesticated plants, its origin is very uncertain. It has been cultivated in Europe and Asia time out of mind. Beans have been long known in Britain; but it is only of late years that they were extensively cultivated upon general soils, being formerly considered as adapted only to rich and moist clays. At that time they were all sown according to the broad-cast system; in which way, instead of benefiting the ground, they were of incalculable detriment. Weeds got away at the outset, and in dry seasons often ruined the crop; whilst in every season the grass or perennial weeds which happened to be in the ground increased in strength and in quantity, the openness of the bean crop at bottom allowing them to thrive without interruption.

5223. *The drilling of beans with a small mixture of peas is now become a general practice* in every well cultivated district of the north, more particularly in those where soil and climate permit the practice to be successfully executed. In this way not only heavy crops are raised, but, what is of great importance, the ground is kept constantly in good order, provided suitable attention is bestowed upon the cleaning process. This is generally carried on by horse-hoeing the crop at different times, so long as the hoe can be used without doing damage; and in this way an able auxiliary is brought forward to the assistance of summer fallow, whereby less stress need be laid upon that radical process than otherwise would be indispensably necessary. (*Brown.*)

5224. *The varieties of the bean may be included under two general heads*, — the white or garden beans, and the grey or field beans.

5225. *Of the white or garden beans (Fève de marais, Fr.) sown in the fields*, the mazagan and long-pod are almost the only sorts. Of the grey beans, that known as the horse bean, the small or ticks, and the prolific or Heligoland, are the chief sorts. New varieties are procured in the same manner as in other plants. A variety is in use in some parts of Lincolnshire, called the winter bean (*Féverole d'hiver*, Fr.). It is planted in October in the usual manner, and is ready to harvest in the last week in July or the first week in August. They are said to have been introduced from the Continent in 1825. We have lately seen a field of this bean at the Oaks Farm, near Woking, in Surrey, which was planted in October 1829, and in full bloom May 12th following. This circumstance, after so severe a winter, is a proof to us that this is a most valuable variety. (*Gard. Mag.* vol. vi.)

5226. *In the choice of sorts*, tick beans are supposed by some farmers to be more productive than horse-beans; but the latter grow higher in the stem, and produce a more stagnated state of the air, or smother the land more, consequently are the most suitable for the stronger sorts of soil; and Young remarks, that “the common little horse-bean has the advantage of all others in being more generally marketable; for in certain situations it is not always easy to dispose of ticks, Windsors, long-pods, and various other large sorts. They also grow higher, shade the ground in summer more from the sun, and yield a larger quantity of straw, which makes excellent manure. But some of the other sorts are generally supposed to yield larger products. In purchasing beans for seed, care should be taken to choose such as are hard and bright, without being shrivelled in their appearance.”

5227. *The best soils for beans are clays and strong loams*. On such soils they generally succeed wheat or oats, but sometimes also clover leys. Turnip soils or sands are by no means proper for them.

5228. *In the preparation of the soil much depends on the nature of the land and the state of the weather*; for as beans must be sown early in the spring, it is sometimes impossible to give it all the labour which a careful farmer would wish to bestow. It must also be regulated in some measure by the manner of

sowing. In all cases it ought to be ploughed with a deep furrow after harvest or early in winter; and as two ploughings in spring are highly advantageous, the winter furrow may be given in the direction of the former ridges, in which way the land is sooner dry in spring than if it had been ploughed across. The second ploughing is to be given across the ridges, as early in spring as the ground is sufficiently dry; and the third furrow either forms the drills or receives the seed. (*Supp. E. Brit. art. Agr.*)

5229. *Brown*, one of the best bean-growers in Britain, gives the following directions:—The furrow ought to be given early in winter, and as deep as possible, that the earth may be sufficiently loosened and room afforded for the roots of the plant to search for the requisite nourishment. This first furrow is usually given across the field, which is the best method when only one spring furrow is intended; but as it is now ascertained that two spring furrows are highly advantageous, perhaps the one in winter ought to be given in length, which lays the ground in a better situation for resisting the rains, and renders it sooner dry in spring, than can be the case when ploughed across. On the supposition that three furrows are to be given, one in winter and two in spring, the following is the most eligible preparation:—The land being ploughed in length as early in winter as is practicable, and the cross gutter and headland furrows sufficiently dug out, take the second furrow across the first as soon as the ground is dry enough in spring to undergo the operation; water-furrow it immediately, and dig again the cross gutter and headland furrows, otherwise the benefit of the second furrow may be lost. This being done, leave the field for some days till it is sufficiently dry, when a cast of the harrows becomes necessary, so that the surface may be levelled; then enter with the ploughs and form the drills. (*Treatise on Rural Affairs.*)

5230. *Manure is frequently applied to the bean crop*, especially if it succeeds wheat. By some, dung is spread on the stubble previously to the winter ploughing; but this cannot always be done in a satisfactory manner, at least in the northern parts of the island, unless during frost, when it may lie long exposed to the weather before it can be turned down by the plough. The most desirable mode, therefore, is to lay the manure into drills immediately before the beans are sown. (*Supp. &c.*)

5231. *The best way*, according to *Brown*, is to apply the dung on the stubble before the winter furrow is given, which greatly facilitates the after process. Used in this way, a fore stock must be in hand; but where the farmer is not so well provided, spring dunging becomes necessary, though evidently of less advantage. At that season it may either be put into the drills before the seed is sown, or spread upon the surface and ploughed down, according to the nature of the drilling process which is meant to be adopted. Land dunged to beans, if duly hoed, is always in high order for carrying a crop of wheat in succession. Perhaps better wheat, both in respect of quantity and quality, may be cultivated in this way than in any other mode of sowing.

5232. *The climate* most favourable to the bean is one neither very dry nor very moist; the first brings on the fly, and the last prevents the setting of the blossoms. In general, however, a dry summer is most favourable to the production of seed, and moist weather to the growth of the haulm.

5233. *The time of sowing* beans is as early as possible after the severity of winter is over; in the south, sometimes in January, but never later than the end of March, as the ripening of the crop and its safe harvesting would otherwise be very precarious in this climate. *Bannister* thinks that the proper time for planting beans in Kent is towards the latter end of January or early in the following month; though this business may be continued with advantage till the middle or latter end of March, if the weather should prevent their being got in at an earlier season: but in general it is best to embrace the first opportunity of sowing them after Candlemas, as they often miscarry when the season is procrastinated beyond that time, especially if a dry summer should succeed.

5234. *The mode of sowing* is almost always in rows. Though still sown broad-cast in several places, and sometimes dibbled, they are for the most part drilled by judicious cultivators, or deposited after the plough in every furrow, or only in every second or third furrow. In the latter method the crop rises in rows, at regular intervals of nine, eighteen, or twenty-seven inches, and the hand-hoe ought invariably to be employed; but it is only where the widest interval is adopted that the horse-hoe can be used with much effect in their subsequent culture.

5235. *There are two modes of drilling beans*. In one of these the lands or ridges are divided by the plough into ridgelets or one bout stitches, at intervals of about twenty-seven inches. If dung is to be applied, the seed ought to be first deposited, as it is found inconvenient to run the drill-machine afterwards. The dung may then be drawn out from the carts in small heaps, one row of heaps serving for three or five ridgelets, and it is evenly spread and equally divided among them in a way that will be more minutely described when treating of the culture of turnips. The ridgelets are next split out or reversed, either by means of the common plough or one with two mould-boards, by which means both the seed and the manure are perfectly covered. When beans are sown by the other method, in the bottom of a common furrow, the dung must be previously spread over the surface of the winter or spring ploughing. Three ploughs then start in succession, one immediately behind another; and a drill harrow either follows the third plough or is attached to it, by which the beans are sown in every third furrow, or at from twenty-four to twenty-seven inches asunder, according to the breadth of the furrow-slice.

5236. *Another approved way of sowing beans*, when dung is applied at seed-time, is to spread the dung and to plough it down with a strong furrow; after this shallow furrows are drawn, into which the seed is deposited by the drill-machine. Whichever of these modes of sowing is followed, the whole field must be carefully laid dry, by means of channels formed by the plough, and when necessary by the shovel; for neither then nor at any former period should water be allowed to stagnate on the land.

5237. *The dibbling of beans* is considered by *Arthur Young* as an excellent method when well performed; but the grand objection to it is the difficulty of getting it well done.

5238. *When dibbling becomes the common husbandry of a district*, the workmen find that great earnings are to be made by it, and this is much too apt to make them careless and eager to earn still more; and if a very minute attention is not paid to them by the constant attendance of the farmer, they strike the holes so shallow that the first peck of a rook's bill takes the seed, and acres may be destroyed if the breed of those birds be encouraged. Boys are employed for weeks together to keep the fields, but all works that depend on boys are horribly neglected, and thus the farmer suffers materially; however, if the seed is deposited two and a half or (better) three inches deep, it is not so easily eradicated. In some districts, as Middlesex, Surrey, &c., the method is to plant this pulse in rows struck out by a line, by which a great saving is made in the article of seed, a circumstance which is thought to compensate for the extraordinary charge of this mode of husbandry; and thus far it may be fairly acknowledged that the method of planting beans by the dibber is greatly to be preferred to that of sowing the seed at random. The economy of this agricultural process is thus explained:—The rows are marked out one foot asunder,

and the seed planted in holes made two inches apart : the lines are stretched across the lands, which are formed about six feet over ; so that when one row is planted, the sticks to which the line is fastened are moved by a regular measurement to the distance required, and the same method pursued till the field is completed. The usual price for this work is ninepence per peck, and the allowance two bushels per acre. Great confidence must necessarily be reposed in the people who transact the business of planting beans by the dibber ; for, if inclined to fraud, they have it in their power to deceive their employer, by throwing a great part of the seed into the hedge ; by which means their daily profits are considerably enhanced, their own labour spared, and every discovery effectually precluded till the appearance of the crop. Then, indeed, the frequent chasms in the rows will give sufficient indications of the fraud ; but by this time perhaps the villainous authors of the mischief may have escaped all possibility of detection, by having conveyed themselves from the scene of their iniquity.

5239. *The quantity of seed* allowed is very different in the southern and northern parts of Britain : in the former, even when the rows are narrow, only two bushels or two bushels and a half ; but in Scotland, seldom less than four bushels to the English statute acre, even when sown in ridgelets twenty-seven inches distant, and a bushel more when sown *broad-cast*. When beans are sown or planted thick, the top pods only fill to the number of three, and four, and half a dozen ; when thin, the plants will pod and fill to the bottom. Both in the broad-cast and drill husbandry, it is common to mix a small quantity of peas along with beans. This mixture improves both the quantity and quality of the straw for fodder, and the pea straw is useful for binding up the sheaves in harvest.

5240. *The after culture* of the bean crop commences with harrowing just before the young plants reach the surface. When sown in rows, in either of the modes already mentioned, the harrows are employed about ten or twelve days after ; and, being driven across the ridgelets, the land is laid completely level for the subsequent operations, and the annual weeds destroyed.

5241. *After the beans have made some growth*, sooner or later, according to the state of the soil with regard to weeds, the horse-hoe is employed in the intervals between the rows ; and followed by the hand-hoe for the purpose of cutting down such weeds as the horse-hoe cannot reach ; all the weeds, that grow among the beans beyond the reach of either hoe, should be pulled up with the hand. The same operations are repeated as often as the condition of the land, in regard to cleanness, may require.

5242. *Before the introduction of the horse-hoe*, which merely stirs the soil, and cuts up the weeds, a common small plough, drawn by one horse, was used in working between the rows, and is still necessary where root-weeds abound. This plough goes one bout, or up and down in each interval, turning the earth from the beans, and forming a ridgelet in the middle ; then hand-hoes are immediately employed ; and, after some time, a second hand-hoeing succeeds, to destroy any fresh growth of weeds. The same plough, with an additional mould-board, finally splits open the intermediate ridgelet, and lays up the earth to the roots of the beans on each side. The benefit of laying up the earth in this manner, however, is alleged to be counterbalanced by the trouble which it occasions in harvest, when it is difficult to get the reapers to cut low enough ; and it may be properly dispensed with, unless the soil is very wet and level.

5243. *In moist warm seasons*, this grain hardly ever ripens effectually ; and it is exceedingly difficult to get the straw into a proper condition for the stack. In such cases, it has been found of advantage to switch off the succulent tops with an old scythe blade set in a wooden handle, with which one man can easily top-dress two acres a day. This operation, it is said, will occasion the crop to be ready for reaping a fortnight earlier, and also, perhaps, a week sooner ready for the stack-yard after being reaped.

5244. *Before reaping beans* the grain ought to be tolerably well ripened, otherwise the quality is impaired, whilst a long time is required to put the straw in such a condition as to be preserved in the stack. In an early harvest, or where the crop is not weighty, it is an easy matter to get beans sufficiently ripened ; but, in a late harvest, and in every one where the crop takes on a second growth, it is scarcely practicable to get them thoroughly ripened for the sickle. Under these circumstances, it is unnecessary to let beans stand uncut after the end of September, or the first of October ; because any benefit that can be gained afterwards, is not to be compared with the disadvantages that accompany a late wheat seed-time.

5245. *Beans are usually cut with the sickle*, and tied in sheaves, either with straw ropes, or with ropes made from peas sown along with them. It is proper to let the sheaves lie untied several days, so that the winning process may be hastened, and, when tied, to set them up on end, in order that full benefit from the air may be obtained, and the grain kept off the ground. (*Brown.*)

5246. *Beans are sometimes mown*, and, in a few instances, even pulled up by the roots. They should in every case be cut as near the ground as possible, for the sake of the straw, which is of considerable value as fodder, and because the best pods are often placed on the stems near the roots. They are then left for a few days to wither, and afterwards bound and set up in shocks to dry, but without any head sheaves. (*Supp. &c.*)

5247. *Beans are stacked* either in the round or oblong manner ; and it is always proper, in the northern counties at least, if the stack is large, to construct one funnel or more to allow a free circulation of air.

5248. *The threshing of beans* is nearly as easy as that of peas. Threshing them by a machine may be considered advantageous as breaking the coarser ends of the straw, and separating the earth from their root-ends, or roots, if they have been reaped by pulling.

5249. *The produce of beans*, when proper management is exercised, and where diseases have not occurred, is generally from twenty-five to thirty-five bushels per acre. Donaldson says, that a crop of beans, taking the island at large, may be supposed to vary from sixteen to forty bushels, but that a good average crop cannot be reckoned to exceed twenty. In Middlesex, Middleton tells us, that bean-crops vary from ten to eighty bushels per acre. They are rendered a very precarious crop by the ravages of myriads of small black insects of the Aphis kind. The lady-birds (*Coccinella*) are supposed to feed on them, as they are observed to be much among them. Foot says, the average produce is from

three and a half to four quarters per acre. In Kent, A. Young thinks, they probably exceed four quarters; but in Suffolk, he should not estimate them at more than three; yet five or six are not uncommon.

5250. *The produce in haulm*, in moist seasons, is very bulky.

5251. *In the application of beans*, the grain in Scotland is sometimes made into meal, the finer for bread, and the coarser for swine; but beans are for the most part applied to the purpose of feeding horses, hogs, and other domestic animals. In the county of Middlesex, all are given to horses, except what are preserved for seed, and such as are podded while green, and sent to the London markets. When pigs are fed with beans, it is observed that the meat becomes so hard as to make very ordinary pork, but good bacon. It is also supposed that the mealmen grind many horse-beans among wheat to be manufactured into bread.

5252. *The flour of beans is more nutritive than that of oats*, as it appears in the fattening of hogs; whence, according to the respective prices of these two articles, Dr. Darwin suspects that peas and beans generally supply a cheaper provender for horses than oats, as well as for other domestic animals. But as the flour of peas and beans is more oily, he believes, than that of oats, it may in general be somewhat more difficult of digestion; hence, when a horse has taken a stomachful of peas and beans alone, he may be less active for an hour or two, as his strength will be more employed in the digestion of them than when he has taken a stomachful of oats. A German physician gave to two dogs, which had been kept a day fasting, a large quantity of flesh food; and then taking one of them into the fields, hunted him with great activity for three or four hours, and left the other by the fire. An emetic was then given to each of them; and the food of the sleeping dog was found perfectly digested, whilst that of the hunted one had undergone but little alteration. Hence it may, he says, be found advisable to mix bran of wheat with the peas and beans, a food of less nutriment, but of easier digestion; or to let the horses eat before or after them the coarse tussocks of sour grass, which remain in moist pastures in the winter; or, lastly, to mix finely cut straw with them. It is observed in the fifth volume of *The Bath Papers*, that it has been found by repeated experience, that beans are a much more hearty and profitable food for horses than oats. Being out of old oats the two last springs, the writer substituted horse-beans in their stead. In the room of a sack of oats with chaff, he ordered them a bushel of beans with chaff, to serve the same time. It very soon appeared the beans were superior to the oats, from the life, spirit, and sleekness of the horses.

5253. *Bean straw*, when mixed with peas, Brown considers as affording almost as much nourishment when properly harvested as is gained from hay of ordinary quality; when it is well got the horses are fonder of it than of pea straw. It should either be given when newly threshed, or else stacked up and compressed by treading or coverings, as the air is found materially to affect both its flavour and nutritive quality.

5254. *The produce of beans in meal* is, like that of peas, more in proportion to the grain than in any of the cereal grasses. A bushel of beans is supposed to yield fourteen pounds more of flour than a bushel of oats, and a bushel of peas eighteen pounds more, or, according to some, twenty pounds. A thousand parts of bean flour were found, by Sir H. Davy, to yield 570 parts of nutritive matter, of which 426 were mucilage or starch, 103 gluten, and 41 extract, or matter rendered insoluble during the process.

5255. *The diseases of beans* are, the rust, mildew, black fly or A'phides, and in consequence the honey dews.

5256. *A'phides, when they live on beans*, are of a dirty bluish-black colour, similar to those on the elder and cherry. The larvæ of the *Coccinella septempunctata*, as well as the perfect insects, devour the A'phis. Several of the small summer birds, viz. largest willow-wren, middle, and smallest wren, white-throat, lesser white-throat, black-cap, and Dartford warbler, also live on them. The A'phides of beans are brought on by very dry weather: they are most prevalent on the summits of the plants; and some have attempted to mitigate the evil by cutting off the tops. In general, however, the disease is without remedy, either preventive or positive. In extreme cases they destroy the leaves, stalks, and fruit; and when this is foreseen, the best thing the farmer can do is to mow the crop or plough it down, and prepare the land for wheat or otherwise, according to the rotation.

SECT. III. *The Tare*. — *Vicia sativa* L.; *Diadélphia Decándria* L., and *Leguminòsæ* J. *Vesce commun de printemps et d'hiver*, Fr.; *Wicke*, Ger.; *Loglio*, Ital.; and *Arveja*, Sp.

5257. *The tare, vetch, or fitch* (*Vicia sativa*, fig. 742.), has been cultivated for its stem and leaves from time immemorial. It is considered as a native plant, and is found wild also in China and Japan. Ray, in 1686, informs us, that the common tare or vetch was then sown almost all over Europe; that it was chiefly used in England, mixed with peas and oats, to feed horses; but that it was sometimes sown separately for soiling cattle, and was reputed to cause milch cows to yield much milk. The tare, Brown observes, is of hardy growth, and, when sown upon rich land, will return a large supply of green fodder for the consumption of horses, or for fattening cattle.

5258. *The varieties of tares* are chiefly two, the winter and spring tare; both have local names, as gore vetch, rath ripe vetch, &c. Some consider them as distinct species, but this is doubtful.

5259. *As the result of an experiment* tried for two years at Bury, in Suffolk, Professor Martyn observes, that there appears a material difference in the constitution, if we may so call it, of the two tares in question. Not to say any thing of a trifling difference in the colour and size of their seeds, the only visible mark of distinction seems to be a disparity in the first leaves of the upright stalks, which in the spring

742



tares are elliptic, and rounded or notched at the end, but in the winter tare linear and drawn to a point. The leaves on the branches which afterwards issue below, and in time form the bulk of the plants, are the same in both vetches. But, whatever the difference may be, it is evident that the seeds of the two sorts ought to be kept separate; since each sown out of its proper season is found not to prosper.

5260. *New varieties of tare* may be obtained by the usual means; and it is thought that some of the numerous species of this plant, which are natives of Europe, might be cultivated with advantage. The French cultivate a variety which they call *Vesce blanche*, or *Lentille du Canada*, *Vicia sativa* alba. They include also among their forage vetches *Vicia angustifolia*, *Cracca*, *Pseudo-Cracca*, biennis, sèpium, and lùtea. The *Vicia narbonensis* and *serratifolia* are cultivated in Germany. Dr. Anderson has recommended the *V. sèpium*; and a writer in *The Bath Agricultural Transactions*, the *V. Cracca*. Some species of *Láthyus*, *O'robis*, and *Ervum* might probably also be tried with success.

5261. *In choosing* between the spring and winter tare, every thing must depend on the intention of the crop. If the object is to have early feed, the winter variety is undoubtedly to be preferred; but where the land is foul and requires to be two or three times ploughed in spring, or where a late crop is desired, or a crop for seed, then the spring variety will generally deserve the preference.

5262. *The soil* preferred by the tare is a clay, but they will grow in any rich soil not over dry. In a moist climate, the haulm grows so luxuriant as to rot at bottom; and in one over dry it is deficient in length. A dry season, however, is on the whole more favourable than a moist one, as this crop soon covers the surface.

5263. *The preparation of the soil* seldom consists of more than one ploughing, if for autumn sowing; and of a winter and spring ploughing, when to be sown in spring. If in the latter case the land is very foul, several ploughings are given, or one ploughing and several stirrings with the cultivator. In general, tares succeed some of the corn crops. In England manure is sometimes given either with a view to eating them off early, and following with a crop of turnips, or to enriching the soil for a crop of wheat.

5264. *The time of sowing* depends on the kind of tare, and the purpose in view.

5265. *The winter variety* is sown in September and October; and the first sowing in spring ought to be as early as the season will permit. If they are to be cut green for soiling throughout the summer and autumn, which is the most advantageous method of consuming them, successive sowings should follow till the end of May. Summer tares, when meant for seed, Brown observes, ought to be sown early, "otherwise the return will be imperfect; but when for green food, any time betwixt the first of April and the latter end of May will answer well, provided crops in succession, from the first to the last-mentioned period, be regularly cultivated. Instances are not wanting of a full crop being obtained even when the seed was sown so late as the middle of June, though sowing so late is a practice not to be recommended. In Middlesex, the winter sowings are commenced about the beginning of August: in the northern counties no winter-sowings are made, as the tare there will not endure the severity of that season.

5266. *The mode of sowing tares* is mostly broad-cast, which should be performed as evenly as possible over the surface of well-prepared land; the seeds being afterwards covered in by proper harrowing, in order to prevent their being picked up by birds, and ensure their perfect vegetation and growth. It has been suggested, however, that, in rich clean soil, it is probable the row-method would succeed well with this sort of crop, which, as Marshal states, is the practice in some of the southern districts of the island. After the seed is sown, and the land carefully harrowed, a light roller ought to be drawn across, so that the surface may be smoothed, and the scythe permitted to work without interruption. It is proper also to guard the field for several days against the depredations of pigeons, who are remarkably fond of tares, and will pick up a great part of the seed, unless constantly watched.

5267. *The quantity of seed* to an acre is from two and a half to three and a half bushels, according to the time of sowing, and to whether they are to be consumed green or left to stand for a crop.

5268. *When tares are intended for seed*, less seed is required than when they are grown for soiling or for drying the haulm. A writer in *The Farmer's Magazine* (vol. i.) has suggested, that the most productive method of sowing this crop, when intended for seed, is to mix them amongst beans when drilled, at the rate of one firlot of tares to one boll of beans. From trials made it is ascertained, it is said, that the quality of the tares is vastly improved by being blended with beans, as, by clinging to the latter, they are kept from the ground, and enjoy the full benefit of the sun for ripening them in a perfect manner; and they are in this way much easier harvested than when sown by themselves. They answer, at the same time, for bands to tie the principal crop; and the produce may, on an average of seasons, be considered as at least double. A little rye sown with winter tares, and a few oats with the spring sort, not only serve to support the weak creeping stems of the tares, but add to the bulk of the crop by growing up through the interstices.

5269. *In the choice of the seed* it is hardly possible to distinguish the grain of the winter from that of the spring variety: the former is alleged to be rather smaller and lighter coloured; but the only reliance must be on the honesty of the vendor. Plump seed, and a sample free from the seeds of weeds, will of course be selected, whatever be the variety.

5270. *The after culture* given to tares consists merely in pulling out the larger weeds, unless they are in rows, in which case the horse or hand hoe is applied; or intended for seed, in which case weeding must be more particularly executed.

5271. *In reaping tares for soiling* they ought always to be cut with the scythe, as the sickle, by breaking asunder the stalks, and tearing up a number by the roots, renders the second crop of little value. When mown early, they will in a moist season produce three mowings, but generally two. In reaping tares for seed, they may be either mown or taken with the sickle, and treated like peas in drying, stacking, and threshing.

5272. *Tares are eaten off the ground* in some places by different kinds of live stock, particularly by sheep; and as the winter-sown variety comes early in spring, the value of this rich food is then very considerable. The waste, however, in this way, even

though the sheep are confined in hurdles, must be great ; and still greater when consumed by horses or cattle.

5273. *Tare crops are sometimes made into hay*, in which case more attention is found necessary than in those of most of the artificial grasses, as wet is more injurious to them, and they require more sun and air ; but in other respects they demand the same cautious management, in order to preserve the foliage from being lost. . The time for cutting for this purpose is, according to the author of *The Synopsis of Husbandry*, when the blossoms have declined and they begin to fall and lie flat. When well made, the hay is of the best and most nutritious quality.

5274. *The produce of tares cut green* is, according to Middleton, ten or twelve tons per acre, which is a large crop ; and when made into hay about three tons per acre, which shows the disadvantage of making these crops into hay. It is found that the spring tare-crops are lighter, and most liable to be injured by a dry season.

5275. *The produce in seed* is likewise found to be considerable, being by some stated at from three to six sacks ; but in other instances forty bushels, or more, have been obtained from the acre.

5276. *In the application of tares* they are found to be a hearty and most nourishing food for all sorts of cattle.

5277. *Cows give more butter* when fed with this plant than with any other food whatsoever. Horses thrive better upon tares than they do upon clover and rye-grass ; and the same remark is applicable to the fattening of cattle, which feed faster upon this article of green fodder than upon any kind of grass or esculent with which we are acquainted. Danger often arises from their eating too much, especially when podded ; as colics, and other stomach disorders, are apt to be produced by the excessive loads which they devour. Perhaps a great quantity of fixed air is contained in this vegetable ; and as heavy crops are rarely dry at the root when cut, it is not to be wondered that accidents often happen, when the animal is indulged with the unrestrained consumption of them. Were oat straw mixed with the tares in the racks or stalls in which they are deposited, it is probable that fewer accidents would follow, though this assistant is only required when the tares are wet, foul, or over succulent. If the plants are cut green, and given to live stock, either on the field or in the fold-yards, there is, perhaps, no green crop of greater value, nor any better calculated to give a succession of herbage from May to November. The winter-sown tare, in a favourable climate, is ready for cutting before clover. The first spring-crop comes in after the clover must be all consumed or made into hay ; and the successive spring sowings give a produce more nourishing for the larger animals than the aftermath of clover, and may afford green food at least a month longer. In the county of Sussex, Young observes, "tare crops are of such use and importance that not one tenth of the stock could be maintained without them ; horses, cows, sheep, hogs, all feed upon them ; hogs are soiled upon them without any other food. This plant maintains more stock than any other plant whatsoever. Upon one acre Davis maintained four horses in much better condition than upon five acres of grass. Upon eight acres he has kept twelve horses and five cows for three months without any other food ; no artificial food whatever is equal to this excellent plant." This statement must be coupled with the usual produce of turnips in Sussex, 10 or 15 tons per acre : hence the supposed superiority of tares to every other green crop. Tares cut green, Professor Thaer observes, draw no nourishment from the soil whatever ; while made into hay, they afford a fodder preferred by cattle to pea straw, and more nutritive than hay or any other herbage.

5278. *The use of the grain of tares* is generally for reproduction ; but they are also given to pigeons, by which they are highly relished, and it is thought they would form a very good food for poultry. In Germany they are given to horses, cows, sheep, and swine.

5279. *The diseases of tares* are so few as to be of no consequence. A crop is sometimes, but rarely, lost by mildew.

SECT. IV. Various Legumes which might be cultivated in British Farming.

5280. *The lentil, kidneybean, and chick pea* are grown both in France and Germany, as field plants, for their seeds, which are used as food. They are by no means likely to become articles of general culture in Britain ; but it is worth while to know that they may be cultivated here instead of being imported, and also that they form very excellent articles of human subsistence.

5281. *The lentil* is the *E'rvum Léns* L. ; *Lentillon*, Fr. ; *Lentzen*, Ger. ; and *Lenticcia*, Ital. (fig. 743.)



It is a legume of the greatest antiquity, being in esteem in Esau's time, and much prized in Eastern countries ever since. In Egypt and Syria, they are parched in a frying-pan and sold in the shops, and considered by the natives as the best food for those who undertake long journeys. The lentil is considered a native of France, but has been known in England from the earliest agricultural records. In Gerarde's time they were sown like tares, their haulm given to cattle, and the seed to pigeons, and used in meagre soups.

5282. *There are three varieties of lentils* cultivated in France and Germany : the small brown, which is the lightest-flavoured, and the best for haricots and soups ; the yellowish, which is a little larger, and the next best ; and the lentil of Provence, which is almost as large as a pea, with luxuriant straw, and more fit to be cultivated as a tare than as food for man. The French have also a winter lentil, *Lentillon d'hiver* ; and they cultivate the *E'rvum Ervilia*, *Lentille Erse ou Ervillier*, and the *E. monánthos*, *Len à une fleur*, *Jarosse d'Auvergne*. The Spanish lentil, — *Gesse cultivée*, *Lentille d'Espagne*, Fr. , *Lenteja*, Span., — is the *Láthyrus sativus*. (fig. 744.) It is sometimes grown in gardens in this country, and occasionally in the fields in France. The lentil of Canada, *Lentille du Canada*, Fr., is the

Vicia pisifórmis Lin. (fig. 745.) *Vicia Ervilia* Willd., *E'rvum tetraspérmum* Lin., and *E. hirsútum* Lin., are also cultivated in some places as lentils ; and indeed the seeds of all the tribe *Viciæ* (*Encyclopædia of Plants*, p. 1066.) may be eaten by man.

5283. *A dry, warm, sandy soil* is requisite for the lentil ; it is sown rather later than the pea, at the rate of a bushel or a bushel and a half to the acre ; in other respects its culture and harvesting are the same,

and it ripens sooner. The lentil, Young observes, is a crop not uncommon about Chesterford in Essex, where they sow a bushel an acre on one ploughing in the beginning or middle of March. It is there the custom to make hay of them, or seed them for cutting into chaff for trough-meat for sheep and horses, and they sow them on both heavy and dry soils. It is, however, added, that the whole country is of a calcareous nature. It is likewise stated, that attention should be paid not to water horses soon after eating this sort of food, as they are apt to hove them. They are asserted to be cultivated for the same purpose in Oxfordshire, and probably in other districts.

5284. *The produce of the lentil* in grain is about a fourth less than that of the tare; and in straw it is not a third as much, the plants seldom growing above one foot and a half high. The straw is, however, very delicate and nourishing, and preferred for lambs and calves; and the grain on the Continent sells at nearly

744



double the price of peas. Einhoff obtained from 3840 parts of lentils, 1260 parts of starch, and 1433 of a matter analogous to animal matter.

5285. *The use of the lentil* on the Continent is very general, both in soups and dressed with a butter sauce as haricot. They are imported from Hamburgh, and sold in London for the same purpose.

5286. *The chick pea* (*Pisicliche Gauance*, Fr.; *Cicer arietinum*, fig. 52.), grows naturally in the south of Europe, and is cultivated there for the same purposes as the lentil, but it is too delicate for field culture in this country.

745



5287. *The kidneybean* (*Phaseolus vulgaris* L.; *Haricot*, Fr.; *Schminkbohne*, Ger.; and *Fagiuolo*, Ital.) is a native of India, but ripens readily in dry summers in most parts of Britain. Its culture has been hitherto confined to gardens; but it might be grown equally well in dry, warm, rich, and sheltered soils, being grown in the fields of Germany, Switzerland, and in similar climates. The sort generally used for

746



this purpose is the small dwarf white; the ground is prepared by several stirrings, and the seed is dibbled in rows eighteen inches or two feet asunder in the beginning of May. The ground is hoed and weeded during the summer, and the crop is ripe in August. It is usually harvested by pulling up the plants, which, being dried, are stacked or threshed. The haulm is of little bulk or use, but the seed is used in making the esteemed French dish called haricot, which it is desirable the cottagers of this country should be made acquainted with. There is, perhaps, no other vegetable dish so cheap and easily cooked, and at the same time so agreeable and nourishing. The beans are boiled and then mixed with a little salt butter or other fat, and a little milk or water and flour. From 3840 parts of kidneybean, Einhoff obtained 1805 parts of matter analogous to starch, 851 of vegeto-animal matter, and 799 parts of mucilage. Haricots and lentils are much used in all Catholic countries during Lent and *maigre* days, as they, from their peculiar constituents, form so excellent a substitute for animal food. During the prevalence of the Roman religion in this country, they were probably much more generally used than at present; as reformations are often carried farther than is necessary, possibly lentils may have been left off by Protestants, lest the use of them should be considered a symptom of popery.

5288. *The white lupine* (*Lupin blanc*, Fr.; *Lupinus albus* L., fig. 746.) was cultivated by the Romans as a legume, and is still occasionally grown in Italy and France. The seeds were formerly, and are sometimes now, used as food; but more generally the whole plant is mown and given as herbage to cattle, and sometimes the crop is ploughed down as manure.

CHAP. IV.

Plants cultivated for their Roots or Leaves in a recent State as Food for Man or Cattle.

5289. *Plants cultivated for their roots or leaves* are various, and most of them are adapted both for human food and that of domestic animals; but some are chiefly or entirely grown for the nurture of live stock. The plants which we include under this head, are the potato, turnip, carrot, parsnep, beet, cabbage tribe, lettuce, and chiccory. The culture of roots may be considered a branch of farming almost entirely of modern origin, and more peculiarly British than any other department. Turnips were cultivated by the Romans, and in modern times brought into notice as objects of field culture in the last century; but they were most imperfectly managed, and of very little utility in agriculture till their culture was undertaken by the British farmer. The potato, carrot, and parsnep were also first cultivated in the fields of this country. Friable or light soil, superior pulverisation and manuring, the row-method, and careful after-culture, are essential to the maturation of the plants to be treated of in this Chapter; and hence the importance of such crops as preparations for those of the bread corns.

5290. *The nutritive products* of these plants are thus given by Sir H. Davy : —

Systematic Name.	English Name.	In 1000 Parts.				
		Whole quantity of soluble or nutritive matter.	Mucilage or starch.	Saccharine matter or sugar.	Gluten or albumen.	Extract, or matter rendered insoluble during evaporation.
<i>Solànum tuberòsum</i> -	Potato - - - {	From 260 to 200.	From 200 to 155.	From 20 to 15.	From 40 to 30.	
<i>Bèta vulgàris</i> - -	Red beet - - -	148	14	121	13	
<i>elcla</i> - - -	Mangold wurtzel	136	13	119	4	
<i>Bràssica Ràpa</i> - -	Common turnip -	42	7	34	1	
var. <i>rutabàga</i>	Swedish turnip -	64	9	51	2	2
<i>Daúeus Caròta</i> - -	Carrot - - -	98	3	95		
<i>Pastinàca satìva</i> - -	Parsnep - - -	99	9	90		
<i>Bràssica oleràcea</i> - -	Cabbage - - -	73	41	24	8	

SECT. I. *The Potato.* — *Solànum tuberòsum* L.; *Pentándria Monogýnia* L., and *Solàneæ* J. *Pomme de Terre*, Fr.; *Cartoffel*, Ger.; *Tartufflo* or *Pomo di Terra*, Ital.; and *Batata*, Span.

5291. *The potato is ascertained to be a native of South America*, having been found wild both in Buenos Ayres and in Chili; though Humboldt was very doubtful if that could be proved: he admits, however, that it is naturalised there in some situations. Sir J. Banks (*Hort. Trans.* vol. i. p. 8.) considers that the potato was first brought into Europe from the mountainous parts of South America, in the neighbourhood of Quito, where they were called *papas*, to Spain, in the early part of the sixteenth century. From Spain, where they were called *battatas*, they appear to have found their way first to Italy, where they received the same name with the truffle, *taratoufli*. The potato was received by Clusius, at Vienna, in 1588, from the governor of Mons, in Hainault, who had procured it the year before from one of the attendants of the Pope's legate, under the name of *taratouflo*, and learned from him that it was then in use in Italy. In Germany it received the name of *cartoffel*, and spread rapidly even in Clusius's time.

5292. *To England the potato was brought from Virginia* by the colonists sent out by Sir Walter Raleigh in 1584, who returned in July 1586, and "probably," according to Sir Joseph Banks, "brought with them the potato." Thomas Herriot, in a report on the country, published in *De Bry's Collection of Voyages*, (vol. i. p. 17.), describes a plant called *openank* (not *openawk*, as in the *Hort. Trans.*), with "roots as large as a walnut, and others much larger; they grow in damp soil, many hanging together, as if fixed on ropes; they are good food, either boiled or roasted." Gerarde, in his *Herbal*, published in 1597, gives a figure of the potato, under the name of the *potato of Virginia*, whence, he says, he received the roots; and this appellation it appears to have retained, in order to distinguish it from the *battatas*, or sweet potato (*Convòlvulus Batàtas*), till the year 1640, if not longer. "The sweet potato," Sir Joseph Banks observes, "was used in England as a delicacy long before the introduction of our potatoes: it was imported in considerable quantities from Spain and the Canaries, and was supposed to possess the power of restoring decayed vigour. The kissing comfits of Falstaff, and other confections of similar imaginary qualities, with which our ancestors were duped, were principally made of these and of eringo roots."

5293. *The potato was first planted by Sir Walter Raleigh*, on his estate of Youghall, near Cork, and, Gough says, was "cherished and cultivated for food" in that country before its value was known in England; for, though they were soon carried over from Ireland into Lancashire, Gerarde, who had this plant in his garden in 1597, under the name of *Battàta virginiana*, recommends the roots to be eaten as a delicate dish, not as common food. Parkinson mentions, that the tubers were sometimes roasted, and steeped in sack and sugar, or baked with marrow and spices, and even preserved and candied by the comfit-makers. There is a tradition among the peasantry in the county of Galway, that the potato was introduced there previous to its being known in any other part of Ireland, owing to a vessel with some of the roots on board having been wrecked on their coast, and a few of the roots having been roasted by children who found them, they were so much approved of, as to induce the planting of the remainder.

5294. *For encouraging the cultivation of potatoes*, with the view of preventing famine, the Royal Society took some measures in 1633. Still, however, although their utility as an article of food was better known, no high character was bestowed on them. In books of gardening, published towards the end of the seventeenth century, a hundred years after their introduction, they are spoken of rather slightly. "They are much used in Ireland and America as bread," says one author, "and may be propagated with advantage to poor people." — "I do not hear that it hath been essayed," are the words of another, "whether they may not be propagated in great quantities, for food for swine or other cattle." Even the enlightened Evelyn seems to have entertained a prejudice against them: "Plant potatoes," he says, writing in 1699, "in your worst ground. Take them up in November for winter spending; there will enough remain for a stock, though ever so exactly gathered." But the use of potatoes gradually spread, as their excellent qualities became better understood. It was near the middle of the eighteenth century, however, before they were generally known over the country: since that time they have been most extensively cultivated. In 1796, it was found that, in the county of Essex alone, about 1700 acres were planted with potatoes for the supply of the London market. This must form, no doubt, the principal supply; but many fields of potatoes are to be seen in the other counties bordering on the capital, and many ship-loads are annually imported from a distance. In every county in England, it is now more or less an object of field culture.

5295. *Potatoes, as an article of human food*, are, next to wheat, of the greatest importance in the eye of the political economist.

5296. *From no other crop* that can be cultivated will the public derive so much food as from this valuable esculent; and it admits of demonstration, that an acre of potatoes will feed double the number of people that can be fed from an acre of wheat. Potatoes are also a nourishing and healthy food, relished by almost every palate; and it is believed there is hardly a dinner served up for six months in the year without them, in any part of the kingdom. Notwithstanding all these things, and they are of great importance in one point of view, we are doubtful whether potatoes can be placed so high in the scale as

They require a great deal of manure, while, generally speaking, little is returned by them; they are a bulky unhandy article, troublesome in the lifting and carrying processes, and interfering with the seed season of wheat, the most important one to him; and, from particular circumstances, they cannot be vended unless when raised in the vicinity of large towns: hence they are in most respects an unprofitable article. To the farmer, the real criterion is the profit which potatoes will return in feeding beasts; and here, we apprehend, the result will altogether be in favour of turnips, and rutabaga, as the most profitable articles for that purpose.

5297. *What is called the yam, or Surinam potato*, was formerly considered of importance to the farmer, as an assistant to his turnip crop, or rather a succedaneum, which is of material benefit when turnips are consumed; but as this variety cannot be used as human food, the extension of its culture cannot be recommended. By cultivating any of the good eating sorts for the use of cattle, a succedaneum may be had for the human species in years of scarcity.

5298. *The value of potatoes as a fallow crop*, and as an article of food for cattle compared with turnips and cabbages for the same purposes, Marshal observes, may be considered thus:—

5299. *Potatoes are more nutritious*; and, in the opinion of those who have used them, fatten cattle much quicker than either turnips or cabbages. Potatoes, too, being secured from the severities of winter, are a more certain article of fattening than turnips or cabbages; both of which are liable to perish under an alternation of frost and thaw; and the turnip, more particularly, is locked up, or rendered more difficult to be come at, during a continuance of snow or frost. Turnips and cabbages, if they out-weather the severities of winter, occupy the soil in the spring when it should be prepared for the succeeding crop; while potatoes, if properly laid up, are a food which may be continued without inconvenience until the cattle be finished, or the grass has acquired the requisite bite for finishing them in the field. On the other hand, potatoes are a disagreeable crop to cultivate: the planting is a tedious dirty business; and taking them up may be called the filthiest work of husbandry, especially in a wet autumn. A powerful argument for the extensive culture of potatoes as food for live stock is, that in seasons of scarcity they can be adopted as human food. Here, as in many other points, the opinion of Marshal and other English agriculturists is rather at variance with that of the Northumberland and Berwickshire cultivators. In Berwickshire and Roxburghshire, a crop of potatoes is often taken before turnips, by means of which the land is restored to a fertile state.

5300. *The varieties of the potato* are innumerable: they differ in their leaves and bulk of haulm; in the colour of the skin of the tubers; in the colour of the interior compared with that of the skin; in the time of ripening; in being farinaceous, glutinous, or watery; in tasting agreeably or disagreeably; in cooking readily or tediously; in the length of the subterraneous stolones to which the tubers are attached; in blossoming or not blossoming; and, finally, in the soil which they prefer.

5301. *The earliest varieties of the potato* are chiefly cultivated in gardens, and therefore we shall only notice such early sorts as are grown in the fields. These are—

The early kidney, The nonsuch, The early shaw, and The early champion.

The last is the most generally cultivated round London; it is very prolific, hardy, and mealy. Early varieties, with local names, are cultivated near most large towns, especially Manchester, Liverpool, Glasgow, Edinburgh, and the metropolis.

5302. *The late field varieties* in most repute are—

<p>The red-nosed kidney. Large kidney. Bread fruit, raised in 1810, from seed, and esteemed one of the best field potatoes, being white, mealy, well tasted, and prolific. Lancashire pink eye, good.</p>	<p>Black skin, white interior, and good. Purple, very mealy, productive, and keeps well. Red apple, mealy, keeps the longest of any. Tartan, or purple and white skinned, an esteemed Scotch potato, prolific, mealy, exceedingly well tasted, and keeps well.</p>
---	--

5303. *The varieties grown exclusively as food for live stock* are—

<p>The yam or Surinam potato; large, red and white skinned, and the interior veined with red; flavour disagreeable, and not such as to admit of its being used as human food. It succeeds best on heavy lands.</p>	<p>The ox noble; large, yellow without and within, very prolific, not fit to eat. The late champion; large and prolific, white skinned, and may be used as human food.</p>
--	--

5304. *New varieties of potatoes* are procured with the greatest ease. The following directions are given in a useful work on this plant:—Pluck off the apples when the stalk has ceased to vegetate and is drying up. The seed being then fully ripe, break the apple in a hair sieve, wash the pulp clean from the seeds, and dry them in the sun; then sow the seed in beds in March, and take the potatoes up in October. They will attain the size of nutmegs, or at most be no larger than walnuts. Select the fairest and best, and keep them secure from frost by thoroughly drying, and intermixing, and covering them with sifted wood or coal-ashes. Plant them in April following, at the distance of fifteen inches asunder; and when the plant is two inches high, hill them with fresh earth. This may be done several times, constantly taking care to keep them clean from weeds. Observe when the stalks decay; some will be found decaying much sooner than others; these are the early kinds, but those that decay last are the sorts which come late. Take them up in rotation as they ripen, and let the produce of each potato be kept separate till the next year. Such as come early may be tried as soon as they are taken up, by dressing one or two: should they be approved, the remainder may be preserved; but those which are late should not be tried before January or February, for it will be found that the late kind of potatoes, newly raised, are very soft, and cut like soap, until they have been hoarded a certain time, when they become mealy. Under each stalk you may expect to find a gallon of potatoes; those planted the third year may, perhaps, produce two sacks; and their increase afterwards will be very considerably greater. Thus it takes full three years to form an adequate judgment of potatoes raised from seed; and, after all, if one in ten succeed so as to be worth preserving, it is as much as can be reasonably expected. In general, the produce of the seed will resemble the parent stock; but red varieties will give both white and red offspring, and among the offspring of kidneys will be found round-shaped tubers. One great advantage of raising varieties from seed is alleged to be the invigoration of the vegetative principle.

5305. *Some of the earlier sorts of potatoes do not blossom*, and consequently do not, under ordinary management, produce seeds. To procure blossoms and seeds from these, it is necessary, from time to time, during the early part of the summer, to remove the earth from the roots of the plants, and pick off the tubers or potatoes as they begin to form. By thus preventing the strength of the plant from being employed in forming tubers at the root, it will flow into the leaves and herbage, and produce blossoms and apples. Knight, the president of the Horticultural Society, by adopting this practice, succeeded in procuring seeds from some sorts of potatoes which had never before produced blossoms; and from these seeds he raised excellent varieties, some hardy and less early, others small and very early. He farther impregnated the blossoms produced by these early potatoes with other sorts, some early and some late (in the way in which graziers cross the breeds of cattle to improve the offspring), and he succeeded in producing varieties, more early than late sorts, and more hardy and prolific than any early potatoes he had seen.

These he cultivated in his fields, deeming them preferable to all other sorts as admitting of later planting and earlier removal; and this practice he justly considered as highly favourable to the succeeding crop of wheat.

5306. *In choosing a sort* or sorts of potatoes from the numerous varieties which are to be found every where, perhaps the best way is, for the selector to procure samples and taste them, and to fix on what best pleases his palate. The shaw is one of the best early potatoes for general field culture; and the kidney and bread-fruit are good sorts to come in in succession. The Lancashire pink is also an excellent potato; and we have never in any part of the British Isles tasted a potato equal in mealiness and flavour to this variety, as cultivated round Prescot, near Liverpool. The red apple and tartan are of undoubted preference as late or long keeping potatoes. The yam is decidedly the best potato for stock, and will produce from twelve to fifteen tons per acre.

5307. *The soil* in which the potato thrives best is a light loam, neither too dry nor too moist, but if rich, it is so much the better. They may, however, be grown well on many other sorts of lands, especially those of the mossy, moory, and similar kinds, where they are free from stagnant moisture, and have had their parts well broken down by culture, and a reasonable portion of manure added. The best-flavoured table potatoes are almost always produced from a newly broken up pasture ground not manured; or from any new soil, as the site of a grubbed up copse or hedge, or the site of old buildings or roads. Repeated on the same soil they very generally lose their flavour. The yam produces the largest crops on a loamy and rather strong soil, though it will grow well on any that is deeply ploughed and well manured.

5308. *In preparing the soil for potatoes*, it is of much importance to free it as completely as possible from root weeds, which cannot be so well extirpated afterwards, as in the culture of turnips, and some other drilled crops, both because the horse-hoe must be excluded altogether at a time when vegetation is still vigorous, and because at no period of their growth is it safe to work so near the plants, especially after they have made some progress in growth. It is the earlier time of planting, and of finishing the after-culture, that renders potatoes a very indifferent substitute for fallow, and in this respect in no degree comparable to turnips. For this reason, as well as on account of the great quantity of manure required, their small value at a distance from large towns, and the great expense of transporting so bulky a commodity, the culture of potatoes is by no means extensive in the best managed districts. Unless in the immediate vicinity of such towns, or in very populous manufacturing counties, potatoes do not constitute a regular rotation crop, though they are raised almost every where to the extent required for the consumption of the farmer and his servants, and, in some cases, for occasionally feeding horses and cattle, particularly late in spring. The first ploughing is given soon after harvest, and a second, and commonly a third, early in spring; the land is then laid up into ridgelets, from twenty-seven to thirty inches broad, as for turnips, and manured in the same manner.

5309. *The best manure for the potato* appears to be littery farmyard dung; and the best mode of applying it, immediately under the potato sets. Any manure, however, may be applied, and no plant will bear a larger dose of it, or thrive in coarser or less prepared manure: even dry straw, rushes, or spray of trees, may be made use of with success. It is alleged, however, that recent horse manure, salt, and soapers' ashes, have a tendency to give potatoes a rank taste, and to render them scabby.

5310. *The best climate* for the potato is one rather moist than dry, and temperate or cool, rather than hot. Hence the excellence of the Irish potatoes, which grow in a dry, loamy, calcareous soil, and moist and temperate climate: and hence, also, the inferiority of the potatoes of France, Spain, and Italy, and even Germany. In short, the potato is grown nowhere in the world to the same degree of perfection as in Ireland and Lancashire, and not even in the south of England so well as in Scotland, and the north and western counties: all which is, in our opinion, clearly attributable to the climate.

5311. *The season for planting* potatoes in the fields, depends much on the soil and climate. Where these are very dry, as they always ought to be for an early crop, the sets are usually put in the ground in March or earlier; but for a full crop of potatoes, April is the best time for planting. Potatoes, indeed, are often planted in the end of May, and sometimes even in June; but the crops, although often as abundant, are neither so mellow nor mature as when the sets are planted in April, or in the first eight or ten days of May. For seed, however, they are preferable.

5312. *In preparing the sets of potatoes*, some cultivators recommend large sets, others small potatoes entire, and some large potatoes entire. Others, on the ground of experience, are equally strenuous in support of small cuttings, sprouts, shoots, or even only the eyes or buds. With all these different sorts of sets, good crops are stated to have been raised, though tolerable-sized cuttings of pretty large potatoes, with two or three good eyes or buds in each, are probably to be preferred.

5313. *Independently of the increased expense of the seed*, it is never a good practice to make use of whole potatoes as sets. The best cultivators in Ireland and Scotland invariably cut the largest and best potatoes into sets, rejecting, in the case of kidney potatoes, the root or mealy end as having no bud, and the top or watery end as having too many. No objection is made to two or even three buds on each set, though one is considered sufficient. A very slight exercise of common sense might have saved the advocates for shoots, scooped out eyes, &c., their experiments and arguments; it being evident, as Brown has observed, to every one with any practical knowledge of the nature of vegetables, that the strength of the stem at the outset depends in direct proportion upon the vigour and power of the set. The set, therefore, ought to be large, rarely smaller than the fourth part of the potato; and if the potato is of small size, one half of it may be profitably used: at all events, rather err in giving over-large sets, than in making them too small; because by the first error no great loss can be sustained; whereas, by the other, a feeble and late crop may be the consequence. It is ascertained beyond doubt in Lancashire, Cheshire, and other counties in the north and west of England, that sets taken from the top or watery end of the potato, planted at the same time with sets taken at the root or mealy end, will ripen their tubers a fortnight sooner. It is ascertained also, and accounted for on the same general principle, that the plants raised from unripe tubers are both vigorous and more early than such as are raised from tubers perfectly ripe. (See *Gard. Mag.* vol. ii.)

5314. *Sets should always be cut some days before planting*, that the wounds may dry up; but no harm will result from performing this operation several weeks or months beforehand, provided the sets are not exposed too much to the drought so as to deprive them of their natural moisture.

5315. *The quantity of sets* depends on the size of the potatoes; in general, where the sets are sufficiently large, from eight to ten cwt. will be required for an acre: more than ten for yams, and fewer than eight cwt. for the early nonsuch and ash-leaved.

5316. *The modes of planting the potato* are various.

5317. *Where spade culture is employed*, they are very frequently planted on beds (provincially lazy-beds), of four or six feet wide, with a trench or gutter of a foot or eighteen inches in width between, which supplies soil for earthing up the potatoes. This is the rudest mode of planting and cultivating potatoes, and unworthy of being imitated either on a farm or in a garden. The next mode is planting on a plain surface, either with or without manure, according to the state of the soil. Here the sets are placed in rows, with a distance of from eighteen inches to two feet and a half between the rows according to the kind of potato, and from four to nine inches in the rows. In planting, a hole for each set is made by a man with a spade, while a woman or boy drops the set, and the earth is replaced; or the potato dibber is used, and the ground afterwards slightly harrowed. Another mode of planting on a plain surface, when the soil is inclined to be dry, is in some cases practised, which is, after the land has been brought into a proper condition by ploughing over twice or oftener and well harrowed, to spread the manure regularly over the whole surface, the sets being planted in every third furrow, and the dung with the fine earth turned upon them by the next furrow of the plough. In this way the manure is however placed upon the sets, which has on experiment been fully shown to be injurious to the produce. Besides, from the whole of the surface of the ground being covered with dung, a considerably larger proportion must be requisite than when deposited only in the drills, and of course the crop cannot be cultivated to advantage in that respect.

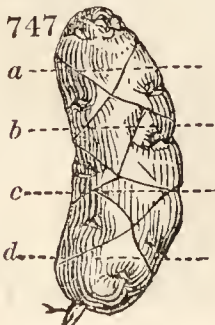
5318. *In planting the potato on sward land*, after it has been prepared by the use of a plough that just pares off the surface and deposits it in the furrow, it is advised by Somerville to place the sets upon the inverted sod, and cover them with the loose mould from below by means of a common plough; or the trench plough may be used with perhaps more advantage; but a better method is that of paring and burning. In some cases the practice is, however, to turn down the turf with or without manure, and then to put in the sets by a dibble; though the former is probably the better practice, as the turfy material on which the sets are put soon begins to decay, and the purpose of a manure is in some measure answered by it. It is a plan that may be adopted with advantage where manure is scarce, as in bringing waste and other coarse grass lands into the state of preparation for grain crops.

5319. *A mode of planting potatoes and at the same time trenching the land*, is practised in Lancashire, and in some districts in the north-east of Scotland. The farmer having carried the dung, and laid it on the field in heaps, at proper distances, the operation is performed by the manufacturers and people who rent the field, and in the following manner:—Across the end of the ridge a trench is formed, about three feet wide, and from ten to fourteen inches deep, according to the depth and quality of the subsoil. That being done, a second trench of the same breadth is marked off, and the surface-soil, to the depth of six or eight inches, is thrown into the bottom of the former trench, over which a sufficient quantity of dung being laid, the potatoes are planted at the distance of eight or ten inches from each other, and then as much earth is taken from the bottom of the second trench as is necessary for covering the potato sets, and making up the first trench to its former level. Thus the field being completely trenched, well manured, and kept thoroughly clean by repeated hand-hoeings, must not only produce an abundant crop of potatoes, but must also be in high condition for receiving whatever kind of seed may be afterwards sown.

5320. *The mode of planting potatoes* practised by the best farmers of the northern districts, is in drills formed by the plough in the same manner as in preparing the land for turnips. The soil is laid up into ridgelets from twenty-seven to thirty inches broad, the manure is distributed between them, and on this manure the sets are placed from four to eight inches asunder: they are then covered by reversing the ridgelets.

5321. *The planting of early potatoes* is carried to a very high degree of perfection in Lancashire. It is stated in *The Lancashire Agricultural Report*, in respect to the raising of seed potatoes, that upon the same ground from which a crop has already been taken, the early seed-potatoes are in some places afterwards planted; which, after being got up about November, are immediately cut up into sets, and preserved in oat husks or saw-dust, where they remain till March, when they are planted, after having had one sprout taken off, which is also planted. The sprouts are of a length sufficient to appear above ground in the space of a week. But the most approved method is, to cut the sets, and put them on a room-floor, where a strong current of air can be introduced at pleasure, the sets laid thinner, as about two layers in depth, and covered with the like materials (chaff or saw-dust) about two inches thick: this screens them from the winter frosts, and keeps them moderately warm, causing them to vegetate; but at the same time admits air to strengthen them, and harden their shoots, which the cultivators improve by opening the doors and windows on every opportunity afforded by mild soft weather. They frequently examine them; and when the shoots are sprung an inch and a half, or two inches, they carefully remove one half of their covering, with a wooden rake, or with the hands, taking care not to disturb or break the shoots. Light is requisite, as well as air, to strengthen and establish the shoots; on which account a green-house has the advantage of a room, but a room answers very well with a good window or two in it, and if to the sun still better. In this manner they suffer them to remain till the planting season, giving them all the air possible by the doors and windows, when it can be done with safety from frost: by this method the shoots at the top become green, leaves are sprung, and are moderately hardy. They then plant them in rows, in the usual method, with a setting-stick; and carefully fill up the cavities made by the setting-stick; by this method they are enabled to bear a little frost without injury. The earliest potato is the superfine white kidney; from this sort, upon the same ground, have been raised four crops, having sets from the repository ready to put in as soon as the others were taken up; and a fifth crop is sometimes raised from the same lands, the same year, of transplanted winter lettuce. The first crop had the advantage of a covering in frosty nights. It is remarked that this useful information was communicated by J. Blundell, Ormskirk, and has hitherto been known only among a very few farmers.

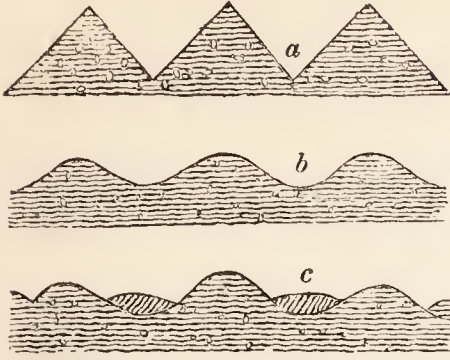
5322. *In the western parts of Lancashire* the early potato is cultivated in the fields in warm situations, and brought to market in the end of May and during June. The chief sorts there grown for this purpose are, the lady's finger, or early Rufford kidney, and the early round potato. The cultivators, aware that the buds from the root and top end of the tuber germinate at different periods, assort their sets in the following manner:—The sets near the top end (*fig. 747. a*) are found to come to maturity a fortnight earlier than those at the root end (*d*); and these, therefore, form two classes of sets for an earlier and a later crop. The sets from the middle (*b, c*) are put together for an intermediate crop. The sets are planted in the month of March or beginning of April, in drills of twenty-four drills in twenty yards, in the following manner:—



After the drills are formed (*fig. 748. a*), loose earth is brushed with a spade or harrowed down, to the depth of six inches, in the interval between them (*b*); dung is then placed over this loose earth, to the depth of four or five inches (*c*); the potato sets of the earliest degree (*fig. 747. a*) are then laid on the manure, at four or five inches apart, for the early crop; and sets of the second degree (*fig. 747. b.*), at from six to eight inches apart, for later crops; and so on. The sets for the early crop are then covered with a spade, to the depth of two inches, and subsequently covered, at two or three different times, to the depth of about five inches. The second and third crops are usually covered with the plough.

Some lay the potatoes intended for plants early in the year, before they are wanted to be cut, loose and separate in straw, or on warm boarded floors; and others put them on flakes or frames, in warm situations near the fire, for the same purpose, in order that they may sprout; and when so sprouted to the length of half an inch or an inch, they are then carefully cut as described, assorted, and planted. (*Gard. Mag.* vol. i. p. 407.)

748



5323. *In the north of Lancashire* the potatoes are removed from their winter quarters in the last week of January, and spread out on a floor or placed on shelves in a room where a fire is kept, or in an upper room of a warm house. On the 2d of February they are covered with a blanket or woollen cloth for about four weeks, which is then taken off in order to harden the sprouts. Towards the latter end of March the sprouts will be found about two inches long, and, if they are carefully set, the potatoes will be ready in seven or eight weeks afterwards. Some bring the sets forward by spreading them out and slightly covering them with light mould under the stage or on the shelves of a greenhouse, or in a cucumber frame, or in a loft over a stable or cow-house. (*Gard. Mag.* vol. ii. p. 48.)

5324. *In Denbighshire* the early potatoes cultivated are the Foxley, the Nelson, and the Rufford kidney. Potatoes intended for sets the following year are taken up before they are ripe, just when the outer skin peels off, and before the stalk or stem begins to wither; they are then laid upon a gravel walk, or any dry surface fully exposed to the sun: they remain in that situation for a month or six weeks, when they become quite green and soft, as if roasted, and often much shrivelled; they are then put away in a cellar or pit, where they will remain dry, and neither invaded by frost nor much heat. In February they are examined, and every eye being then generally found full of long sprouts, they are fit to be planted. The tubers are therefore cut, seldom into more than two sets, viz. the eye or top part, which is planted by itself, and found to come a fortnight earlier; and the root or bottom part, which succeed them. (*Gard. Mag.* vol. ii. p. 172.)

5325. *In gardens in the south of England* potatoes are planted in a warm border from the first week of October, till the latter end of November. They are placed nine or ten inches under the surface, and well covered with dung. About the latter end of March they begin to appear above the surface, when the ground is deeply haeked with a mattock, and made very loose about the plants; then in a fortnight or three weeks move the surface again, but the plants need not be earthed up unless they are very much exposed to the wind, when a little may be drawn about them to keep them steady. By this method fine ash-leaved kidney potatoes may be gathered by the 12th or 15th of May, even in situations not very favourable for early crops, and nearly three weeks earlier than they can be gathered from sets planted in the same situation in the latter end of February; and if ordinary care is taken in planting, no danger need be apprehended from the frost. (*Gard. Mag.* vol. vi. p. 59.) Every farmer knows that, among the corn raised after a crop of potatoes, potato plants will be found which can only have sprung from tubers preserved there all the winter, in consequence of having been buried by the plough deeper than the frost could reach. It is evident, therefore, that this garden mode of raising a crop of early potatoes might be adopted in the field, more especially where the soil was dry; but the success would depend entirely on the deep pronging or grubbing of the soil between the rows early in spring. This might be done to the same degree of perfection as in the garden by the excellent implements of Wilkie or Kirkwood. (2656. and 4955.)

5326. *In Cornwall* early potatoes are planted in October, spring up a few weeks afterwards, are ready before the autumnal frost stops their growth, and the soil being covered with litter to exclude the frost, they are begun to be used about the end of December, and continue in use till May, when they are succeeded by the spring planted crops. Of late years Covent Garden market has received supplies of early potatoes from Cornwall, treated in the above manner. (*Gard. Mag.* vols. ii. v. vi.) Early potatoes, when they first come through the ground, are liable to be injured by spring frosts; but there is an easy and effectual remedy to every cultivator who will take the trouble—and that is to water them, so as to thaw off the frost before sunrise. In Ayrshire, where even late potatoes are liable to this injury, acres are sometimes so watered on a single farm; all the hands being called to business by the break of day, and the water being sprinkled on the young sprouts, from vessels of any sort, by means of a handful of straw. A garden-pot and rose would of course answer better.

5327. *The after culture* of potatoes consists in harrowing, hoeing, weeding, and earthing up.

5328. *All potatoes require to be earthed up*, that is, to have at least one inch in depth of earth heaped on their roots, and extending six or eight inches round their stem. The reason of this is, that the tubers do not, properly speaking, grow under the soil, but rather on, or just partially bedded in, its surface. A coating of earth, therefore, is found, by preserving a congenial moisture, greatly to promote their growth and magnitude, as well as to improve their quality, by preventing the potatoes from becoming green on the side next the light. The earth may be thrown up from the trenches between the beds by the spade; or, where the potatoes are planted in rows, the operation may be performed with a small plough, drawn by one horse, or by the hoe. In Scotland, where the potato is extensively cultivated by the farmer, as food for cattle as well as man, the plough is universally used. In Ireland, where the bed, or lazy-bed, manner is adopted, the earth is thrown up from the intervening trenches. The hoe is generally used by market-gardeners.

5329. *The after-culture, where potatoes are planted in ridgelets, as above described* (5319.), commences when the plants begin to rise above the surface. They are then harrowed across, and afterwards the horse hoe, or small hoeing plough, and the hand-hoe are repeatedly employed in the intervals, and between the plants, as long as the progress of the crop will permit, or the state of the soil may require. The earth is then gathered once, or oftener, from the middle of the intervals towards the roots of the plants, after which any weeds that may be left must be drawn out by hand; for when the radicles have extended far in search of food, and the young roots begin to form, neither the horse nor hand-hoe can be admitted without injury.

5330. *The after-culture* adopted in some parts of Devonshire is somewhat singular, and deserves to be noticed. The sets are there generally cut with three eyes, and deposited at the depth of three inches with the spade or dibber: when the first shoot is three inches high, prepare a harrow with thorns interwoven between the tines, and harrow the ground over till all the weeds are destroyed, and not a shoot of the potatoes left. It may seem strange that such an apparent destruction of a crop should cause an increase; but it may be affirmed as an incontestable fact, that by this means the produce becomes more abundant. The reason appears to be this: although three eyes are left to a piece of potato, one always vegetates before the others, and the first shoot is always single; that being broken off, there is for the present a cessation of vegetation. The other eyes then begin to vegetate, and there appear fresh shoots from the broken eye; so that the vegetation is trebled, the earth made loose, and the lateral shoots more freely expanded. If these hints are observed, the produce of potatoes, it is said, will exceed a fifth of the crop obtained by the usual mode of cultivation.

5331. *The culture of potatoes in the district of Kintyre* is thus given by an intelligent writer in the Transactions of the Highland Society.

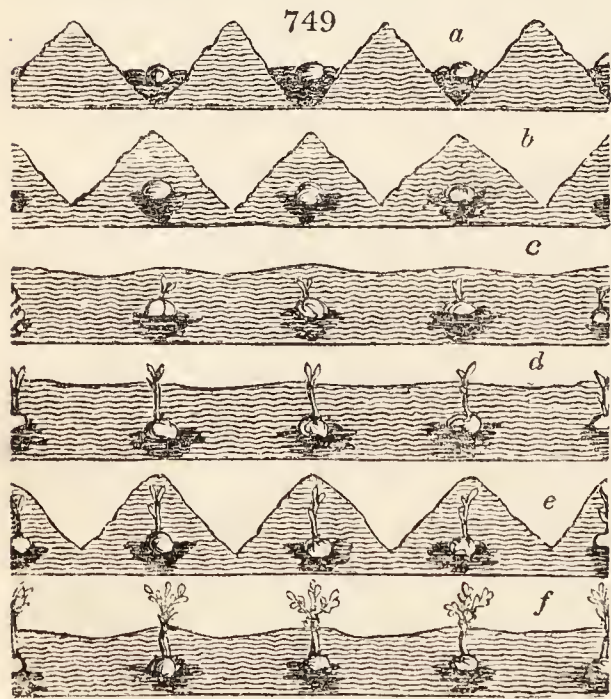
5332. *The land is generally ploughed as early in spring as possible*, and that at least twice. In cases where the two ploughings do not sufficiently pulverise the ground, it receives a third, and after every ploughing is well harrowed. The greatest attention ought always to be given to these preparatory operations.

5333. *The ground being now prepared*, and the season for planting arrived, drills are made for receiving the seed with the common plough; these are drawn about two feet asunder, and three inches in depth. The first seven of them are all drawn from one end of the field, the plough returning out of work from the other end, in order to afford time and room for the operation of putting in the seed, and also the dung, where this last operation is rendered necessary. By the time the ploughman has drawn three of these shallow drills or furrows, the persons in charge of the seed begin to plant the first of them, laying each plant at a distance of from nine to ten inches; these are followed by others who put the dung on the top of it, in the case already mentioned, where the manure is to be put into the drill. The ploughman, having completed seven of these drills, may now proceed to return, by ploughing to the depth of seven inches between the first and second drills, so as to cover the seed in the first. He then opens another of the shallow drills of three inches, at the distance of two feet, as before mentioned, from the last which he had made, being the seventh; and returning back, he makes another of the seven inch deep furrows between the second and third rows of seed, which covers the second: returning, he opens another seed-drill; and back again a deep one, between the third and fourth rows of seed, which covers the third row; and so on from each end of the field. In this manner the drilling and planting will proceed, without any interruption or interference the one with the other, the plough having at first attained a sufficient distance from the planters to have always a drill open before they can overtake it. The great advantage of placing the seed so much nearer the surface than the deeper furrow alongside of it is, that it is more effectually preserved from the bad effects of wet or damp, consequently less liable to be injured by frost, and it springs sooner.

5334. *In this state the field is allowed to remain from a fortnight to three weeks*, when it is cross harrowed to a perfect level. Afterwards, as soon as the drills can be distinguished by the potatoes shooting above the ground, the plough is again applied, and the drills are formed as before; but in doing so, the plough is taken as close as possible to the plant upon both sides; on one side the plough is lightly put in, but on the other it is inserted as deep as possible, throwing the soil over on its neighbouring row of seed, filling up the vacuum which the plough had previously left at it, and forming at the same time a ridge, as it was originally, on the top of the plant. What is thus ploughed in the forenoon is cross harrowed completely level during the same afternoon. The great advantage which I apprehend to be derived from this process is the loosening of the soil, destroying the weeds, and the saving of hand-hoeing. I am satisfied, from my own particular experience and observation, that this mode of treating the young growth of the potato is far preferable to any other I have seen practised, either here or elsewhere, however forbidding the rough usage thus given to the young plant may appear to one inexperienced in this particular mode of cultivating it.

5335. *As soon as the weeds begin to appear*, the plough is again introduced, which, in the idiom of this country, is called "taking from the potatoes," which is done by running pretty close to the plant on both sides, so that a slight ridge is thrown up between the line of plants; and in this situation they remain for eight days, when the plant is "put to" by again applying the plough between the rows, and separating the earth composing the middle ridge above mentioned, towards the plant on each side, but without covering it. After this, the process of "putting to" of earth is continued as the plant grows, and takes place at least twice, until the stems are so high that a single horse going among them may seriously injure them. The "putting to" will now be understood as a deeper insertion of the plough in the middle of the drill. The whole of the labour of ploughing, drilling, "taking from," and "putting to" the potatoes, as above described, is performed with the common plough." (*Highl. Soc. Trans.* vol. viii. p. 68.)

5336. *The field culture of the potato in Argyleshire* is thus given by an experienced cultivator in the *Gardener's Magazine*. The manure is sometimes applied to the field during winter and ploughed in, or it is by the better economists reserved till the field is drilled for planting. When the first plan is adopted, another ploughing is given across the field, which is then planted, the plough going one bout along the furrow of which the set is placed, and then covered by the return of the plough. The best way is to prepare the field in the same way as for turnips, and place the dung in the drill, and the set on it (*fig. 749. a*), and



then cover them up by clearing down the ridgelet, and forming others (*b*): a fortnight or so afterwards, the whole field is harrowed across (*c*). As soon as the plants have so far sprouted as that the drill can safely be traced from end to end (*d*), then the whole field is drilled again, as at first, with a very strong furrow (*e*), and then the harrows are set immediately to work after the plough has finished drilling, and the field is levelled again (*f*). Any one that is unacquainted with the system would suppose the crop ruined, but it is far otherwise. The after-culture is no way different from the common practice of paring away the earth, drill harrowing, and earthing up, as in other countries. It is advisable only to pare or earth, as the case may be, one side of the drill at each turn; as, by this means, the operations are sooner performed at the time, the earth can be more frequently stirred, and at the same expense. The charm of this system consists in the additional drilling up and harrowing down; by this harrowing, all the larger clods are thrown to the furrow, where they are fully pulverised by the drill harrow and after culture, and all the weeds are so effectually drawn from between the plants that there is no use of hand-hoeing. The expense may be calculated at less than a third of hand-hoeing, from the effect and expedition; of course, dry weather is the time for the second drilling and cross harrowing to be performed. (*Gard. Mag.* vol. ii. p. 316.)

5337. *Pinching off the whole of the potato blossoms* is a part of after-culture not unworthy the attention of the farmer. This may at first sight appear too minute a matter to enter into the economy of farm management. But when it is considered that the seed is the essential part of every plant, and that to which the ultimate efforts of nature are always directed, it will be allowed that an important part of the nourishment of every vegetable must be devoted to this purpose. In the case of the potato, every person knows that the weight of the potato-apples, grown by a single plant, is very considerable. Now we have seen (5304.) that apples may be produced instead of tubers in early potatoes; whence it may justly be inferred, that more tubers may be produced in late ones by preventing the growth of the apples. Such was the reasoning of Knight; and, by repeatedly making the experiment, he came to this conclusion, that in ordinary cases of field culture, by pinching off the blossoms of late crops of potatoes, more than one to a

per acre of additional tubers will be produced. The experiments are related in the second volume of *The Horticultural Transactions*, and the practice is similar to one common among the growers of bulbous roots in Holland, as alluded to by Dr. Darwin, who also recommends its application to the potato. A woman or boy will crop the blossoms from an acre of potatoes in a day, or even in less time, when the crop is not excessively luxuriant.

5338. *The taking of the crop of potatoes on a small scale is generally performed with the spade or three-pronged fork; but under judicious farm management, and the row culture, by the common plough.*

5339. *The coulter is removed and the plough goes first along one side of all the ridgelets of a ridge, or any convenient breadth, and then, when the potatoes so brought to view are gathered by women placed at proper distances, it returns and goes along the other side. When the land is somewhat moist, or of a tenacious quality, the furrow-slice does not give out the roots freely, and a harrow which follows the plough is commonly employed to break it and separate them from the mould. Various contrivances have been resorted to for this purpose. A circular harrow or break, of very recent invention, to be attached to the plough, has been found to answer the purpose well, and to effect a considerable saving of labour. A machine for taking up and collecting potatoes is said to have been invented by Mr. Michael Barry of Swords near Dublin; but though we have written to that gentleman, we have been unable to procure a description or drawing of his invention.*

5340. *A mode of taking part of a crop suited to cottagers and others, especially in years of scarcity, deserves to be mentioned. Having ascertained that some of the tubers have attained an eatable size, go along the rows and loosen the earth about each plant with a blunt stick, taking two or three of the largest tubers from each and returning the earth carefully. By keeping the edge of the blunt spatula or spade perpendicular to the main stem of the plant, the flat side will be parallel to the radiating roots, by which means they will be comparatively little injured. By this means both an early supply, and the advantage of two crops, may be obtained; for the tubers which remain will increase in size, having now the nourishment destined to complete the growth of those removed.*

5341. *Potatoes intended for seed should be taken up a fortnight or three weeks before being fully ripe, for reasons that have been given in treating of early potatoes, and will be recurred to in treating of the diseases of this plant. The ill shaped, small, bruised, or diseased tubers should be laid aside, and the fairest and best dried in the sun, spread on a cellar or loft floor, and covered with ashes, or chaff of sufficient thickness to keep out the frost. In this state they may remain till wanted for cutting. Some persons in Ireland plant potatoes from which they intend to procure sets extremely late, namely, the first week in July. The produce consequently never attains the same degree of size or ripeness as that of an earlier planted crop.*

5342. *Potatoes are stored and preserved in houses, cellars, pits, pies, and camps. Whatever mode is adopted, it is essential that the tubers be perfectly dry, otherwise they are certain of rotting, and a few rotten potatoes will contaminate a whole mass.*

5343. *The most effectual mode, and that which is generally adopted, consists in putting them into close houses, and covering them well up with dry straw. In some parts of Scotland it is a common practice to dig pits in the potato-field, when the soil is dry and light, and, putting in potatoes to the depth of three or four feet, to lay a little dry straw over them, and then cover them up with earth, so deep that no frosts can affect them. Another method, which is practised in England as well as Scotland, is to put them together in heaps, and cover them up with straw, in the manner of preserving turnips, with this addition, that the heaps are afterwards well covered with earth, and so closely packed together as to exclude frost. The farmers in Lancashire in the course of taking them up sort and separate their potatoes according to their sizes, and are particularly careful to throw aside all those that are spoiled before raising, or that are cut in the taking up. This is a very necessary and proper precaution (although by no means generally attended to), as the crop must have a much better chance for keeping, than when diseased or cut potatoes are stored up with it. It is also of great advantage to have the work performed in a dry season, as the potatoes seldom keep well when taken up wet, or when placed in any sort of repository for keeping while in that state.*

5344. *Potato pies, as they are called, are recommended by Young as the best mode in which potatoes can be stored. A trench, one foot deep and six wide, is dug, and the earth cleanly shovelled out, and laid on one side, and on the bottom of the trench is laid over them a bedding of straw. One-horse carts shoot down the potatoes into the trench; and women pile them up about three feet high, in the shape of a house roof. Straw is then carefully laid over them six or eight inches thick, and covered with earth a foot thick, neatly smoothed by flat strokes of the spade. In this method he never lost any by the severest frosts; but in cases of its freezing with uncommon severity, another coat of straw over all gives absolute security. These pies when opened should each be quite cleared, or they are liable to depredation. To receive one at a time, besides also being at first filled for immediate use, he has a house that holds about 700 bushels, formed of posts from fir plantations with wattled sides, against which is laid a layer of straw, and against the sides exteriorly earth six feet thick at the bottom and eighteen inches at top; the roof flat, with a stack of beans upon it. This he has found frost-tight. The beans keep out the weather, he says, and yet admit any steam which rises from the roots, which, if it did not escape, would rot them.*

5345. *Several other modes of preserving potatoes are in use in different places. In Rutlandshire, Marshal says, the method of laying up potatoes is universally that of camping them; a method somewhat similar to the above, but which requires to be described. Camps are shallow pits, filled and ridged up as a roof with potatoes; which are covered up with the excavated mould of the pit. This is a happy mean, he thinks, between burying them in deep pits and laying them upon the surface. Camps are of various sizes; being too frequently made in a long square form like a corn-rick, and of a size proportioned to the quantity to be laid up. It has, however, been found by experience, that when the quantity is large, they are liable to heat and spoil; much damage having sometimes been sustained by this imprudence. Experienced campers hold that a camp should not be more than three feet wide; four feet are perhaps as wide as it can be made with propriety, proportioning the length to the quantity; or, if this is very large, forming a range of short ones by the side of each other. The usual depth is a foot. The bottom of the trench being bedded with dry straw, the potatoes are deposited, ridging them up as in measuring them with a bushel. On each side of the roof long wheat straw is laid, neatly and evenly, as thatch; and over this the mould raised out of the trench is evenly spread; making the surface firm and smooth with the back of the spade. A coat of coal ashes is sometimes spread over the mould, as a still better guard against frost. It is needless to observe that a camp should have a dry situation; and that the roots ought to be deposited in as dry a state as possible. These camps are tapped at the end, some bavins, or a quantity of loose straw, being thrust close in the open end, as a bung or safeguard. As it is a matter of the highest importance to preserve this root without spoiling during the whole year, it has been suggested, that the best method yet discovered for keeping potatoes sound for the longest period, is to spread them on a dry floor early in the spring, and to rub off the eyes occasionally, as they appear to have a tendency to push out; by using these precautions, Donaldson has frequently seen potatoes kept in good condition till the month of June.*

5346. *In Canada and Russia the potato is preserved in boxes in houses or cellars, heated when necessary to a temperature one or two degrees above the freezing point by stoves. (Farm. Mag. vol. xx. p. 449.)*

5347. *To keep potatoes any length of time*, the most effectual way is to place them in thin layers on a platform suspended in an ice cellar. There the temperature being always below that of active vegetation, they will not sprout; while not being above one or two degrees below the freezing point, the tubers will not be frost bitten. Another mode is to scoop out the eyes with a very small scoop, and keep the roots buried in earth. A third mode is to destroy the vital principle by kiln-drying, steaming, or scalding. A fourth mode is to bury them so deep in dry soil that no change of temperature will reach them, and consequently, being without air, they will remain upwards of a year without vegetating.

5348. *The produce of the potato* varies from five to eight, and sometimes ten or twelve tons per acre; the greatest produce is from the yam, which has been known to produce twelve tons or 480 bushels per acre. The haulm is of no use but as manure, and is sometimes burned for that purpose, being slow of rotting.

5349. *The most important application of the potato crop* is as human food; on this it is unnecessary to enlarge.

5350. *Einhoff found mealy potatoes* to contain twenty-four per cent. of their weight of nutritive matter, and rye seventy parts: consequently, sixty-four and a half measures of potatoes afford the same nourishment as twenty-four measures of rye. A thousand parts of potato yielded to Sir H. Davy from 200 to 260 parts of nutritive matter, of which from 155 to 200 were mucilage or starch, fifteen to twenty sugar, and thirty to forty gluten. Now, supposing an acre of potatoes to weigh nine tons, and one of wheat one ton, which is about the usual proportion; then as 1000 parts of wheat afford 950 nutritive parts, and 1000 of potato say 230, the quantity of nutritive matter afforded by an acre of wheat and potatoes will be nearly as nine to four; so that an acre of potatoes will supply more than double the quantity of human food afforded by an acre of wheat. The potato is perhaps the only root grown in Britain which may be eaten every day in the year without satiating the palate, and the same thing can only be said of the West India yam and bread fruit. They are, therefore, the only substitute that can be used for bread with any degree of success; and indeed they often enter largely into the composition of the best loaf bread without at all injuring either its nutritive qualities or flavour. (*Edin. Encyc. art. Baking.*) In the answer by Dr. Tissot to M. Linquet, the former objects to the constant use of potatoes as food, not because they are pernicious to the body, but because they hurt the faculties of the mind. He owns that those who eat maize, potatoes, or even millet, may grow tall and acquire a large size; but doubts if any such ever produced a literary work of merit. It does not, however, by any means appear that the very general use of potatoes in our own country has at all impaired either the health of body or vigour of mind of its inhabitants.

5351. *The manufacture of potato flour* is carried on to a considerable extent in the neighbourhood of Paris, and the flour is sold at a price considerably higher than that of wheat, for the use of confectioners and for bakers who prepare the finer sorts of bread. The potatoes are washed and grated, and the starch separated from the pulp so obtained by filtration; it is dried on shelves in a room heated by a flue, and afterwards broken on a floor by passing a cast iron roller over it. It is then passed through a bolting machine and put up in sacks for sale. The most complete manufactory in the neighbourhood of Paris in 1829 was that of M. Delisle at Bondy. (*Gard. Mag. vol. vi.*) Most of the operations there are performed by a steam engine attended by children. It is reported by the Count de Chabrol, in his *Statistical Account of Paris*, that 40,000 tons of potatoes are annually manufactured into flour within a circle of eight leagues around that city.

5352. *The quantity of farina which potatoes produce* varies not only according to the species, but according to the period when the extraction takes place. The variations produced by this last cause are nearly as follows:—Two hundred and forty pounds of potatoes produce of farina, or potato flour, in

August, from 23 to 25 pounds.	March from 45 to 38 pounds.
Sept..... 32 ... 38	April..... 38 ... 28
Oct..... 32 ... 40	May..... 28 ... 20
Nov..... 38 ... 45	

The extraction of the farina should be discontinued at the period when the potatoes begin to grow, the farina being destroyed by germination. Red potatoes produce a smaller quantity of farina. Those which are blue on the outside give little, but it is of good quality; the white, which is often tinged with red in the interior, is the least proper for this extraction. The best of all is that which has a yellow tint, as its farina is of very good quality, and abundant. (*Hygie de Bruxelles.*)

5353. *Potato flour is made into bread* in a very simple manner. Its adhesive tendency does not admit of baking or kneading unmixed with meal or wheaten flour; but it may be made into cakes in the following manner:—A small wooden frame nearly square is laid on a flat pan like a frying-pan; this frame is grooved, and so constructed, that, by means of a presser or lid introduced into the groove, the cake is at once fashioned according to the dimensions of the mould. The frame containing the farina may be almost immediately withdrawn after the mould is formed upon the pan; because, from the consistency imparted to the incipient cake by the heat, it will speedily admit of being safely handled. It must not, however, be fired too hastily, otherwise it is apt to become unpleasantly hard and unfit for mastication. This precautionary measure being observed, it will be found, that, where thoroughly ready, the bread of potato flour, even unaided by any foreign ingredient, will eat very palatably. It might thus, from time to time, be soaked for puddings, like the tapioca; or it might be used like the cassada-cake, which in appearance and quality it so much resembles; that is, when well buttered and toasted, it will make an excellent breakfast appendage. (*Quar. Journ. Agr. vol. ii. p. 69.*)

5354. *The meal of potatoes* may be preserved for years closely packed in barrels, or unground in the form of slices; these slices having been previously cooked or dried by steam, as originally suggested by Forsyth, of Edinburgh. (*Encyc. Brit.*) Some German philosophers have also proposed to freeze the potato, by which the feculent matter is separated from the starch, and the latter being then dried and compressed, may be preserved for any length of time, or exported with ease to any distance. (*Annalen des Ackerbaues, vol. iii. s. 389.*)

5355. *The manufacture of tapioca from potatoes* is thus given in the *Quarterly Journal of Agriculture*. The potatoes selected are thoroughly washed, after which they are grated in a machine constructed for the purpose. The parts thus reduced or grated fall into a vessel placed underneath. From this vessel they are removed, and strained into a tub. On the juice being well expressed for the first time, the fibrous matter is set apart, and cold clean water is thrown over them. These fibres are again put through the same strainer, till the whole of the substance is collected, when they are finally cast aside. On this being done, the contents of the tub, now in a state of mucilage or starch, are allowed to settle. A reasonable interval being suffered to elapse, the old water is poured gently off, and fresh water supplied. After this process of fining and washing, the blanched matter is passed through a smaller strainer.

5356. *The offals are separated*. The starch becomes now much whiter; still fresh water is abundantly dashed over it. When by frequent ablation the surface of this vegetable mass is rendered quite smooth and clean, it is filtrated a third and last time.

5357. *The strainer* now used is of very fine texture, so that no improper or accidental admixture may interfere. As soon as the starch, thus purified, has firmly subsided, it is spread on a board, and exposed to the open air. The damp speedily evaporates, on which it is, as a security for cleanliness, put through a sieve.

5358. *A large circular pan* is now procured, and set upon the fire. The farina is gradually put into the pan, till what is conceived to be sufficient for one cooking be supplied. As the natural tendency of the farina, in a warm state, is to adhere to the pan, great care is requisite in constantly turning and stirring it. This is effectually done with a broad flat piece of wood, having a long handle to prevent inconvenience from the heat. A temperature of 150° Fahrenheit suits best for perfecting the tapioca. When the farina becomes quite hard, dry, and gritty, it is then ready, and may be taken off the fire. (*Quar. Journ. Agr.* vol. ii. p. 68.)

5359. *The ordinary economical applications* of the potato, next to those of the culinary and baking arts, are in starch-making and the distillery. Starch is readily made from the scraped and washed tubers cut into small pieces and steeped in water; and a spirit is distilled from mashed potatoes, fermented so as to change a portion of the starch into sugar. In general it is found that three and a half bushels of potatoes afford the same quantity of spirit as one of malt.

5360. *Potash* may be extracted from potato leaves and stalks by the following process:—Cut off the stalks when the flowers begin to fall, as that is the period of their greatest vigour; leave them on the ground eight or ten days to dry, cart them to a hole dug in the earth about five feet square and two feet deep, and then burn them, keeping the ashes red-hot as long as possible. Afterwards take out the ashes, pour boiling water on them, and then evaporate the water. "There remains after the evaporation a dry saline reddish substance, known in commerce under the name of *salin*; the more the ashes are boiled, the greyer, and the more valuable the *salin* becomes. The *salin* must be calcined in a very hot oven, until the whole mass presents a uniform reddish brown. In cooling it remains dry, and in fragments bluish within, and white on the surface; in which state it takes the name of potash." (*Smith's Mechanic*, vol. ii. p. 381.)

5361. *Among extraordinary applications of the potato*, may be mentioned cleaning woollens, and making wine and ardent spirit.

5362. *Cleaning woollens*. The refuse of potatoes used in making starch when taken from the sieve, possesses the property of cleansing woollen cloths, without hurting their colour; and the water decanted from the starch powder is excellent for cleansing silks, without the smallest injury to the colour.

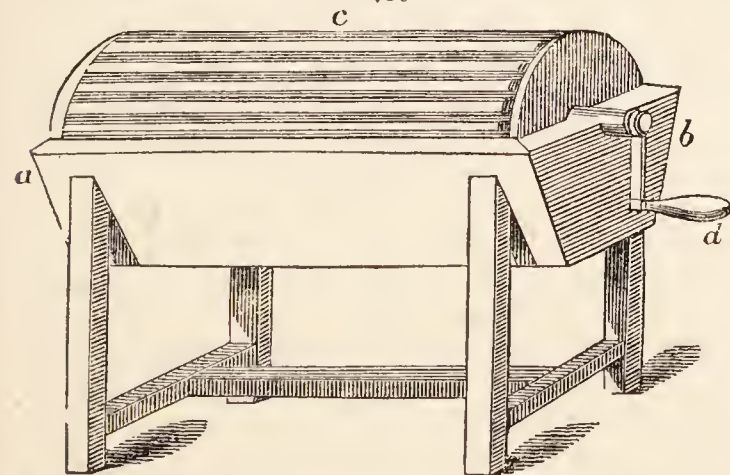
5363. *Wine*, of a good quality, may be made from frosted potatoes, if not so much frosted as to have become soft and watery. The potatoes must be crushed or bruised with a mallet, or put into a cider press. A bushel must have ten gallons of water, prepared by boiling it, mixed with half a pound of hops, and half a pound of common white ginger. This water, after having boiled for about half an hour, must be poured upon the bruised potatoes, into a tub or vessel suited to the quantity to be made. After standing in this mixed state for three days, yeast must be added to ferment the liquor. When the fermentation has subsided, the liquor must be drawn off, as fine as possible, into a cask, adding half a pound of raw sugar for every gallon. After it has remained in the cask for three months, it will be ready for use.

5364. *Ardent spirit*. Potatoes that have been injured by the frost produce a much greater quantity of spirit, and of a much finer quality, than those that are fresh; they require a proportion of malt-wash to promote the fermentation. About one fourth part of malt-worts, or wash, ought to be fermented at least six hours before the potato-wash is joined to it; otherwise the potato-wash, having an aptitude to ferment, will be ripe for the still before the malt-wash is ready; hence the effect will be, to generate an acid which renders the spirit coarse, and, when diluted with water, of a milky or bluish colour. When the spirit is strong, the acid is held in solution; but appears as above, when diluted with water. (*Farmer's Mag.* vol. xvii. p. 325.)

5365. *In the application of potatoes as food for live stock*, they are often joined with hay, straw, chaff, and other similar matters, and have been found useful in many cases, especially in the later winter months, as food for horses, cows, and other sorts of live stock. With these substances, and in combination with others, as bean or barley-meal and pol-lard, they are used in the fattening of neat cattle, sheep, and hogs.

5366. *Potatoes are much more nutritive when boiled*; they were formerly cooked in this way, but are now very generally steamed, especially in the north. The practice has been carried to the greatest extent by Curwen in feeding horses. He gives to each horse, daily, a stone and a half of potatoes mixed with a tenth of cut straw. One hundred and twenty stones of potatoes require two and a quarter bushels of coals to steam them. An acre of potatoes, he considers, goes as far in this way as four of hay. Von Thaeer found them, when given to live stock, produce more manure than any other food: 100 lbs. of potatoes producing 66 lbs. of manure of the very best description. The baking of potatoes in an oven has also been tried with success. (*Comm. Board of Agriculture*, vol. iv.); but the process seems too expensive. Potatoes should not be given *raw* to animals of any description, except, perhaps, when hogs are let in to root and pick up what may have escaped notice in the field. Washing was formerly a disagreeable and tedious business, but is now rendered an easy matter, whether on a large or small scale, by the use of the washing machine.

5367. *Machines for washing potatoes* are numerous, and in addition to that already described, we shall here notice two other forms. One of the simplest is a trough (*fig. 750. a, b*) containing a hollow cylinder (*c*) with a handle (*d*), which is made fast to the axis which passes through the cylinder. "A number of the spars (which run longitudinally) are so constructed as to form a kind of door, which is made fast by two lynch-pins at each end of the cylinder. The vessel being charged with potatoes, and the trough filled with water, all that is necessary for the purpose of cleaning is only to turn the handle of the machine." A machine for washing potatoes by Mr. John Lawson, of Elgin, consists of a wooden or iron trough, with a movable bottom above the fixed one, composed of spars three quarters of an inch apart. The potatoes are laid over the movable ribbed bottom, and water being admitted at one end by a cock, they are moved backwards and forwards by a wooden hoe, till they are clean, when the dirty water which has collected between the two bottoms is let



off by another cock at the opposite end. (*Brit. Farm. Mag.* vol. ii.)

5368. *The boiling of potatoes*, though a simple operation, is in many districts not performed in the best manner. The following is the Lancashire method:—Set them on the fire in cold water; when boiled, pour off the water completely, add a little salt, and dry them well on the fire. Another method:—Choose your potatoes of equal size, and put them into a saucepan, or pot without a lid, with no more water than is sufficient to cover them; more would only spoil them, as the potatoes themselves, on being boiled, yield a considerable portion of water. By being boiled in a vessel without a lid, they do not crack, and all waste

is prevented. After the water is come nearly to boil, pour it off, and replace the hot by cold water, into which throw a good portion of salt. The cold water sends the heat from the surface to the heart of the potato, and makes it mealy. Like all other vegetables, they are improved by being boiled with salt, which ought not, therefore, to be spared. (*Mech. Mag.* i. 13.)

5369. *Frosted potatoes* may be applied to various useful purposes, for food by thawing in cold water, or being pared, then thawed, and boiled with a little salt. Salt, or saltpetre, chaff, or bruised oats, boiled with them, will render them fit food for cattle, swine, poultry, &c. Starch, and paste for weavers, bookbinders, and shoemakers, may be made from them when too sweet to be rendered palatable, and also an ardent spirit, from hydrometer proof to 10 per cent over proof.

5370. *The diseases of the potato* are chiefly the scab, the worm, and curl.

5371. *The scab, or ulcerated surface of the tubers*, has never been satisfactorily accounted for; some attributing it to the ammonia of horse-dung, others to alkali, and some to the use of coal ashes. Change of seed, and of ground, are the only resources known at present for this malady. The worm and grub both attack the tuber, and the same preventive is recommended. The only serious disease of the potato is the curl, and this is now ascertained to be produced by the too great concentration of the sap in the tuber; and this concentration, or thickening, is prevented by early taking up. This discovery was first made by the farmers near Edinburgh, who observed that seed potatoes procured from the moors, or elevated cold ground, in the internal parts of the country, never suffered from the curl, and it consequently became a practice, every three or four years, to procure a change of seed from these districts. On enquiry, it was found, that the potatoes in these upland grounds continued in a growing state till the haulm was blackened by the first frosts of October. They were then taken up, when, of course, they could not be ripe. Subsequent experiments, which will be found detailed in *The Farmer's Magazine*, and *Caledonian and London Horticultural Transactions*, have firmly established the fact, that the curl is prevented by using unripe seed; therefore the farmer ought to select his seed stock a fortnight or three weeks before he takes up the general crop, as already recommended. It is also a safe practice frequently to change the seed, and also to change the variety.

5372. *Shirreff*, an ingenious speculator and practical agriculturist, is of opinion that there are only two causes for the curled disorder in potatoes. The first is excessive seed-bearing, that is, carrying great quantities of plums or apples; from the effects of which, if the plant be not too far advanced in life, it may recover for a time, by removing it to a shady or upland situation. The second cause is time or old age, which never fails ultimately to bring the curled or shrivelled disorder, followed by death, on the whole animal and vegetable kingdoms. An old decaying oak is an instance of the curled or shrivelled state of trees from age, as is "the lean and slippered pantaloons" of the curled disorder from old age in the human species. An apple tree, again, that has carried extraordinary crops of fruit within a few years, is often in the state of a potato curled from excessive apple-bearing; so is a hart, or a buck, immediately after the rutting season. Both the tree and animals will recover their health and vigour for a time, unless they are too old, or have gone to the very greatest and last extremity in seed-bearing and venery, in which cases the effects will be the same as those of time, viz. death. It is not then to over-ripening the tubers that the curled disorder in potatoes is to be attributed, but to time and seed-bearing; that is, carrying great quantities of plums or apples.

SECT. II. *The Turnip*. — *Brássica Ràpa* L.; *Tetradynàmia Siliquosa* L., and *Cruciferae* J. *Rave*, Fr.; *Rübe*, Ger.; *Rapa*, Ital.; and *Nabo*, Span.

5373. *The turnip* is a native of Britain, but in its wild state it is not to be recognised by ordinary observers from wild mustard. It was cultivated as food for cattle by the Romans; and has been sown for the same purpose in the fields of Germany and the Low Countries from time immemorial.

5374. *When they were introduced in this country, as a field plant*, is unknown: but it is probable turnips would be found in some gardens of convents from the time of the Romans; and it is certain that they were in field culture before the middle of the seventeenth century, though then, and for a long time afterwards, in a very inferior and ineffectual manner. It has been stated that turnips were introduced from Hanover in George I.'s time; but so far from this having been the case, George II. caused an abstract of the Norfolk system of turnip husbandry to be drawn up for the use of his subjects in Hanover. (*Campbell's Polit. Survey*, &c. vol. iii. p. 80.) The introduction of improved turnip culture into the husbandry of Britain, Brown observes, "occasioned one of those revolutions in rural art which are constantly occurring among husbandmen; and, though the revolution came on with slow and gradual steps, yet it may now be viewed as completely and thoroughly established. Before the introduction of this root, it was impossible to cultivate light soils successfully, or to devise suitable rotations for cropping them with advantage. It was likewise a difficult task to support live-stock through the winter and spring months; and as for feeding and preparing cattle and sheep for market during these inclement seasons, the practice was hardly thought of, and still more rarely attempted, unless where a full stock of hay was provided, which only happened in very few instances. The benefits derived from turnip husbandry are, therefore, of great magnitude. Light soils are now cultivated with profit and facility; abundance of food is provided for man and beast; the earth is turned to the uses for which it is physically calculated; and, by being suitably cleaned with this preparatory crop, a bed is provided for grass seeds, wherein they flourish and prosper with greater vigour than after any other preparation." (*Treatise on Rural Affairs*.)

5375. *Turnips and clover*, it is elsewhere observed, "are the two main pillars of the best courses of British husbandry; they have contributed more to preserve and augment the fertility of the soil for producing grain, to enlarge and improve our breeds of cattle and sheep, and to afford a regular supply of butcher's meat all the year, than any other crops; and they will probably be long found vastly superior, for extensive cultivation, to any of the rivals which have often been opposed to them in particular situations. Though turnips were long cultivated in Norfolk before they were known in the northern counties, yet it is an undoubted fact that their culture was first brought to perfection in Roxburghshire, Berwickshire, and Northumberland, and chiefly through the exertions of Dawson, of Frogden, in the first named county, and of Culley, in the latter.

5376. *Drilling turnips*, as well as other crops, evidently originated with Tull, whose first work, *Specimen of a Work on Horse-hoeing Husbandry*, appeared in 1731. It appears that Craig, of Arbigland, in Dumfriesshire, began to drill turnips about 1745; and next we find Philip Howard, of Corby, drilling in 1755; and Pringle, drilling "from hints taken from Tull's book," in 1756 or 1757. William Dawson, who was well acquainted with the turnip culture in England, having been purposely sent to reside in those districts

for six or seven years, where the best cultivation was pursued, with an intention not only of seeing, but of making himself master of, the manual operations, and of the minutiae in the practice, was convinced of the superiority of Pringle's mode over every other he had seen, either in Norfolk or elsewhere; and in 1762, when he entered on Frogmore Farm, near Kelso, in Roxburghire, he immediately adopted the practice upon a large scale, to the amount of 100 acres yearly. Though none of Pringle's neighbours followed the example, yet no sooner did Dawson, an actual or rent-paying farmer, adopt the same system, than it was immediately followed, not only by several farmers in his vicinity, but by those very farmers adjoining Pringle, whose crops they had seen, for ten or twelve years, so much superior to their own: the practice in a few years became general. Drilling turnips was first introduced to the county of Northumberland, about the year 1780.

5377. *The varieties of turnip* grown by farmers may be arranged as whites and yellows.

5378. *Of white turnips*, by far the best and most generally cultivated is the globe; but there are also the green-topped, having the bulb tinged greenish; and purple-topped, with the bulb reddish: which, though they do not produce so large a crop as the globe or oval, stand the winter better, and the red-topped, it is said, will keep till February. The pudding, or tankard turnip, has a white bulb which rises from eight to twelve inches high, standing almost wholly above ground. It is less prolific than any of the others, and more liable to be attacked by frost.

5379. *Of yellow turnips*, there are the field or Aberdeen yellow, which is more hardy than the globe, and answers well for succeeding that variety in spring; and the rutabaga, or Swedish turnip, which may be preserved for consumption till June. The Siberian turnip has a bulb and a branchy top, but both of inferior quality. It is a hybrid between a white rutabaga and field cabbage, or between rape and cabbage.

5380. *New varieties* are obtained by selection and by counter impregnation; but in either case the greatest care is requisite to keep the plants at least a furlong from any others of the brassica tribe likely to flower at the same time, otherwise the progeny will certainly be hybridised.

5381. *The choice of sorts* may be considered as limited to the white, globe, yellow, and Swedish, according as early, middling, or late supplies are wanted. No other varieties are grown by the best farmers.

5382. *In the choice of seed* the farmer must rely on the integrity of the seed-dealer, as it is impossible to discover from the grains whether they will turn out true to their kinds.

5383. *Turnip-seed requires to be frequently changed*; and the best is generally procured from Norfolk and Northumberland. The Norfolk seed, Forsyth observes, is sent to most parts of the kingdom, and even to Ireland: but after two years it degenerates; so that those who wish to have turnips in perfection should procure it fresh every year from Norwich, and they will find their account in so doing: for, from its known reputation, many of the London seedsmen sell, under that character, seed raised in the vicinity of the metropolis, which is much inferior in quality.

5384. *Turnip-seed of any age will grow*, if it has been carefully preserved; that which is new, comes up first, and therefore it is not a bad plan to mix new and old together, as a means of securing a braird against drought or the fly. Whether plants from new or old seed are most secure from the depredations of the fly, is perhaps a question which cannot be easily determined, even by experiments; for concomitant circumstances are frequently so much more operative and powerful as to render the difference between them, if there be any, imperceptible. It is, however, known to every practical man, that new seed vegetates several days before the old, and more vigorously; and it is equally well known that the healthy and vigorous plants escape the fly, when the stunted and sickly seldom or never escape it. Hence it would seem, that new seed, *cæteris paribus*, is more secure from the fly than old.

5385. *The soil* for turnips should always be of a light description. In favourable seasons very good crops may be raised on any soil; but from the difficulty of removing them, and the injury which the soil must sustain either in that operation, or in eating them on the spot with sheep, they never on such soils can be considered as beneficial to the farmer. Turnips cannot be advantageously cultivated on wet tenacious soils, but are grown on all comparatively dry soils under all the variations of our climate. On dry loams, and all soils of a looser texture, managed according to the best courses of cropping, they enter into the rotation to the extent of a fourth, a sixth, or an eighth part of the land in tillage; and even on clayey soils they are frequently cultivated, though on a smaller scale, to be eaten by cattle, for the purpose of augmenting and enriching the manure, into which the straw of corn is converted.

5386. *The climate* most desirable for the turnip is cool and temperate. This was long ago noticed by Pliny, and it is so obvious on the Continent that it admits of no dispute. Von Thaer observes that the turnips grown on the fields of Germany seldom exceed half a pound in weight, and that all his care could not raise one beyond fourteen pounds. In France and Italy they are still less. A rapid climate is equally disadvantageous to the turnip; and they are accordingly found of no size in Russia, Sweden, and many parts of North America. Even turnips grown in the southern counties of England, in the same excellent manner as in Northumberland, never equal the size of those grown in the latter county, or further north, or in Ireland.

5387. *The field culture of turnips* is effected either by sowing the seed of the plant from the hand on a flat surface, or by depositing it on the tops of little ridges. In the best cultivated districts, the latter method is universally practised and approved of, chiefly for these reasons:—1. By this method the land may be more easily and perfectly cleaned during the growth of the plants; the width of the rows affording the means of better tilling the intervals. 2. The plants can be more cheaply and quickly hand-hoed, the process being so simple as to be taught to young persons in a few hours; whereas when the plants are not regularly disposed in rows, a considerable degree of experience and time are requisite. 3. The manure may be more perfectly covered, and by being applied in a more effectual manner to the roots of the plants, a smaller quantity will suffice. And lastly, the turnips may be kept drier, and crops of them in conse-

quence raised on land so wet as otherwise to be incapable of yielding a return of any value. We shall give their culture from an excellent paper in the *Quarterly Journal of Agriculture*, vol. i., from which also this paragraph is quoted.

5388. *Preparation of the land.* The land intended for the turnip crop is ploughed in autumn, after the preceding crop of grain has been reaped. If the soil be not of a very dry nature, the land is formed into ridges of fifteen feet or more, and care is taken that no water shall stagnate on the ground. In this condition the land remains during the winter; and it is ploughed again in spring as soon as the ground is sufficiently dry for that purpose, and as soon as the other labour of the farm will allow: this second ploughing is generally made in a direction to cross the previous one. The land is then repeatedly grubbed and harrowed in various directions, for the purpose of pulverising it, and of dragging to the surface, and disengaging all weeds and roots; to assist in which process the aid of the roller is frequently requisite; the roots and weeds disengaged are then gathered with care, and either burnt in little heaps on the ground, or removed away to a larger heap, to be mixed with quick-lime and other substances, to form a compost for the succeeding year; at the same time such stones as impede the tillage may be removed: after this the land is again ploughed, and generally, as before, in a direction crossing the last furrows; and the same process of harrowing, rolling, and collecting the disengaged weeds, is repeated. The earth is once more ploughed, and again the same operations are resorted to; after which the land is usually in a fit state to be formed into ridges or drills. Should this not be so, the operations of ploughing, harrowing, and gathering of weeds must be repeated, and that until the land is cleared of all injurious roots, and reduced to a loose or friable state. The perfect preparation of the ground in this stage of its culture, is of very great importance to the future crop.

5389. *Forming the ridges.* After the preparation described, the land is formed into little ridges or ridgelets, either by the common plough, or by a plough with two mould-boards, formed for that purpose. The first of these is to be preferred when the method of performing the work is once pointed out in the fields. The ridges are formed with a sharp top, as a transverse section (*fig. 751.*) will show. The distance

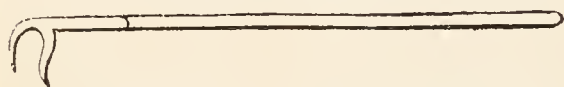
751



of these ridgelets may be from twenty-seven to thirty inches, measuring from top to top. This interval is necessary to allow of the horse-hoe tilling the intervals, in the manner to be afterwards described, and to admit a sufficient circulation of air between the rows of the plants.

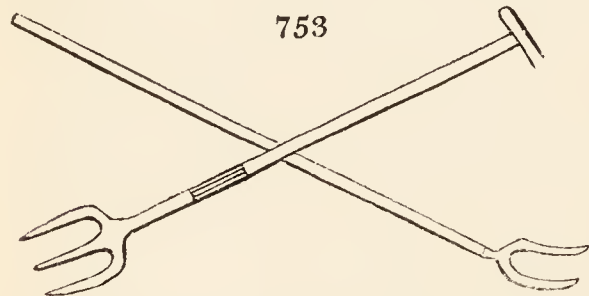
5390. *Manner of applying the manure.* The chief manure applied to this crop is farmyard dung, or that which is produced by the consumption of the straw and other produce of the farm. This manure ought to be well rotted, and to that end either turned over in the court-yard some weeks previously to its being used, or carried out in winter to the fields intended for the turnips, and there laid in one or more large heaps. If the carts are not suffered to go upon these heaps, the putrefactive process will proceed with greater quickness. When the ridgelets are formed in the manner described, the dung is filled into carts drawn by one horse, and transported quickly to the land. The manner of applying it is this:—The horse with the loaded cart walks in the interval of the ridges, so that a wheel of the cart shall go in each of the hollows of the two ridges adjoining. The person who

752



hind follow three young persons, with each a two-pronged or three-pronged fork (*fig. 753.*), each walking

753



new ridge for the reception of the seed is at once

formed, so that a wheel of the cart shall go in each of the hollows of the two ridges adjoining. The person who directs the horse follows the cart, which is open behind, and with a crooked two-pronged fork or dung-hack, (*fig. 752.*) drags out the dung, as the horse moves along, into little heaps in the hollow of every third ridge, at the distance from each other of from eight to ten feet. Behind follow three young persons, with each a two-pronged or three-pronged fork (*fig. 753.*), each walking in the interval of a ridge, and spreading out the dung in as regular a manner as possible; as a cross section of the ridgelets with the dung deposited in the intervals would show (*fig. 754.*)

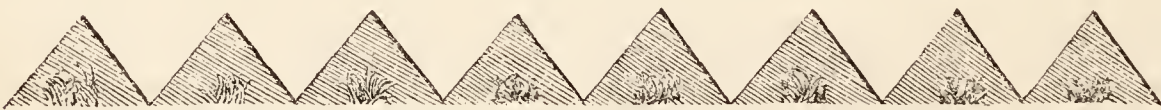
5391. *Covering the dung.* The dung is no sooner spread in this manner than it is covered by the plough. To this end is employed either the common plough, or that with the double mould-board already mentioned: these passing down the middle of each ridgelet split it into two, so that a new ridgelet is formed, whose top is immediately above the former hollow of the old ridgelet, (*fig. 755.*) The dung is now completely covered, and a new ridge for the reception of the seed is at once formed. The double mould-board plough performs this

754



operation at once, the common plough by going and returning up the middle of each ridge.

755



5392. *Broad-cast dunging.* Instead of depositing the manure in the manner described, it is sometimes laid upon the stubble after harvest, and then ploughed in. This is only practicable where there is a supply of manure remaining from the preceding year, or where it can be elsewhere procured; and is only advisable when the land is so clean as to require little preparation in the succeeding spring. As liberal an expenditure as can be afforded of manure is always expedient in the case of this crop, the goodness of which will much depend upon the fertility we are able to communicate to the soil. Ten or twelve tons per acre may be considered the regular manuring on a turnip-farm, where a proper rotation of crops is followed.

5393. *Lime, sea-weed, ashes.* Sometimes lime is applied to the turnip crop, together with dung. This may be done by laying the lime upon the stubble after harvest, or better still, by spreading it upon the ground, and harrowing it well immediately, before the forming of the ridgelets for the reception of the dung. Putrescent manures, however, are considered superior to the calcareous for the production of this plant; and all of the former kind may be used with effect. Street dung is an exceedingly good manure; sea-weed will also be useful: this last, however, is not applied in the manner of the farmyard dung, but is carried off as it is cast on shore, laid on the surface, and suffered to remain so till the land is

ploughed. Ashes generally produce a good effect in causing the seeds to vegetate quickly, but the fertilising powers of some of these do not appear to be of a permanent nature. Bruised bones and various other substances have been used with much benefit; but it is to be observed, that putrescent manures form the main support of the turnip cultivator, and that the others are only to be regarded as subsidiary.

5394. *Sowing the turnips.* The land being formed into ridgelets in the manner described, is ready for the reception of the seed. This is sown on the tops of the ridgelets by machines of various forms.

5395. *The most simple of these* consists of a hollow cylinder of tin, fixed upon an axle, and moving round with two light wheels, distant from each other twenty-seven or thirty inches, which are made to run in the hollows of the ridges. (2688.) The seed is put into the cylinder through an aperture which opens and shuts for that purpose: this cylinder turning round with the axle, the seed drops, through small equidistant holes made in it, into a tin tube, by which it is conveyed to the ground. Immediately before this tube is a hollow coulter of iron, sharp before, which incloses the forepart of the tin tube, and makes a track in the ground from one to two inches deep, into which the seed drops. This simple apparatus is mounted upon a light wooden frame-work, having two shafts behind, by which the workman holds and keeps it steady in its course. It is then attached by a rope to a light wooden roller, in the shafts of which the animal of draught is yoked. More perfect machines, however, may be employed where turnips are cultivated upon a large scale, and we may refer to that of French (2688.) as one of the best.

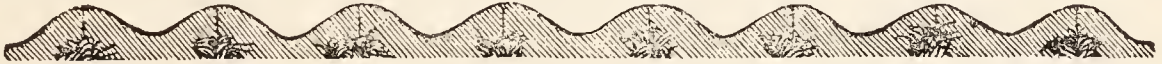
5396. *The preparation of turnip-seed* for sowing, by steeping in the drainings of dung-hills and other similar matters, has been recommended as a likely mode to prevent the fly; but it is not found to have this effect, and is never followed.

5397. *The following mode of preparation is sometimes adopted*:—Half new and half old seed are mixed together; then half is taken and steeped in water for three or four hours; afterwards both steeped and unsteeped seed are mixed and immediately sown. The object of this preparation is to obtain four different brairds or risings of the seed, which are supposed to give four chances of escaping the fly that attacks the infant plants, instead of one. Another mode is to join radish-seed to the above, new and old, steeped in the foregoing manner, it being found that the fly prefers the radish to the turnip. Some recommend the mixing of an equal quantity of rape-seed with the turnip-seed, alleging, that if a fly cuts off the turnips, the rape may be left for a crop; and that if the turnips escape, the rape may be treated as weeds. The most common precaution, however, as to the fly, is to sow thick, or to mix the seed with soot, lime, or ashes.

5398. *The quantity of seed used* may be from two pounds to two and a half pounds avoirdupoise per acre. It is necessary to give a sufficient quantity of seed, to provide against the loss of plants from the ravages of insects, and other contingencies. But the quantity should not be excessive; because the plants, when too thick, get interwoven together, and thence become difficult to be thinned in a proper manner.

5399. *The sowing process being completed*, the ridgelets remain flattened and compressed. (fig. 756.)

756



5400. *The several operations* of forming the ridgelets, spreading the dung, covering it by the plough, and sowing the seed, ought to be carried on in close succession. The dung must be immediately covered, that none of its powers may be lost by evaporation; and the seed, to ensure its early vegetation, ought to be sown as soon as possible upon the moist earth turned up. The various works of the turnip culture, thus carried on at the same time, furnish the best specimen which the culture of the fields affords of the beneficial effects of a proper division of labour. The process has all the appearance and effects of garden culture, with the difference of its being conducted with incomparably greater economy and despatch.

5401. *The period of sowing* in the north of England and Scotland is from the 1st to the end of June, though it is often continued to the middle of July. The turnips, however, sown after the latter of these periods seldom attain to a proper size; and, when sown earlier than the 1st of June, they are apt to shoot forth the seed-stem before winter, by which not only the soil is deteriorated, but the nutritive juices of the root exhausted. In the south of England they may be sown somewhat later than in the north.

5402. *The time of sowing in other countries* must be varied by the nature of the climate and soil. It is to be inferred, that in warmer countries, where vegetation is more rapid, the sowing should be deferred till a later period. At Roville, in the north of France, M. de Dombasle sometimes sows in August, and yet obtains a medium crop.

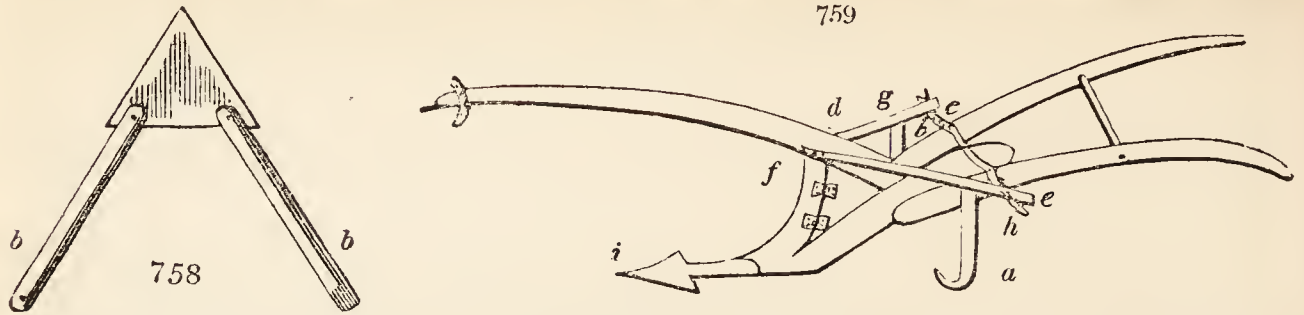
5403. *Hoeing.* When the plants are an inch or more in height, or when weeds appear amongst them, the process of hoeing commences. This is done either by a small plough drawn by one horse, going and returning along the hollow of each ridgelet, and cutting of a slice of earth from the sides, as near to the turnips as possible (fig. 757.)

757



or by the horse-hoe, of which there are various kinds. The most simple of these consists of a flat triangular share (fig. 758. a), with two lateral arms (b, b), formed to set wider or narrower, and fixed to a beam and handles by three upright coulters of iron; or, which is better, the lateral arms are omitted, the triangular share fixed to the beam, and two moveable upright coulters attached by a cross bar.

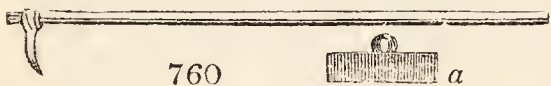
5404. One of the best turnip horse-hoes is formed from the skeleton of a common plough (fig. 759.), by



two coulters of iron curved inwards (a, b), and fixed to wooden bars (e, f, and c, d), which last again are hooked to the beam of the implement, and made, by means of a cross iron bar (g, h), to be set at a greater or smaller distance from each other as it may be required. A broad iron share (i) moves in the middle of the hollow of the ridges, while the two coulters on each side go as near to the rows of turnips as can be done with safety; and in this manner the intervals of the ridges are tilled, and the weeds within them, and as near to the plants as the coulters can go, cut up and destroyed. By removing the wooden bar and coulters of this machine, and hooking to it, on each side, a small cast-iron mould-board, it is converted to the double mould-board plough also, as we have seen.

5405. The brakes or horse-hoes of Wilkie (2666.), Finlayson (2667.), or of Kirkwood (4955.), may easily be set and arranged for this or any other description of culture; so that it requires no new implements.

5406. The hand-hoers go to work, each having a little iron hoe, fixed upon a wooden handle about three feet in length (fig. 760.). The breadth of the blade (a) of this hoe is eight inches; and the workers, standing in the hollow with their faces to the ridges, hoe the turnip plants, leaving them standing singly, at the distance from each other of from ten to twelve inches. By this operation the rows of the turnips are cleaned of all weeds; the superfluous plants cut up and pushed into the intervals, where they die; and the plants to be preserved left standing singly at the distance required. A transverse section of the ridges will then appear thus (fig. 761.), and



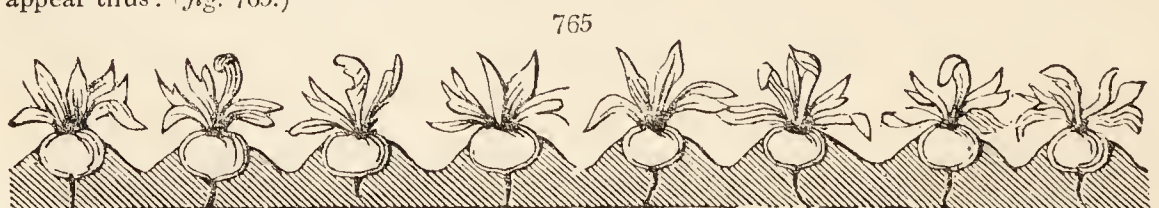
a longitudinal section thus: (fig. 762.) The plants should not be nearer to each other than ten inches, that they may increase to a proper size.



5407. Second horse-hoeing. Soon after the operation in question, weeds will again sprout up in the intervals of the ridges and amongst the plants. In the course, therefore, of twelve days or more the horse-hoe again passes through the intervals of the ridges, cutting up all the weeds that may have sprung up; and soon after the hand-hoers again go to work with the same instrument as before, cutting up all weeds which may have grown amongst the turnips, and carefully singling any plants that may by chance have been omitted in the first hoeing. After this process, a section of the ridges will appear thus: (fig. 763.)



5408. Third horse-hoeing. Sometimes the horse-hoe passes once more down the intervals after a short period; but more generally the previous hand-hoeing concludes the process upon all the drier lands, the weeds being now kept down by the rapid growth of the plant, and the overshadowing of the intervals by its leaves. Very commonly, however, at an interval of eight or ten days after the last hand or horse-hoeing, the earth which had been taken from the roots of the plants by these several hoeings is again laid back, either by the little one-horse plough already mentioned, or by the double mould-board plough, passing down the intervals of the rows and ridging up the earth thus: (fig. 764.) The design in this operation is, that any weeds remaining in the intervals after the former hoeings may be destroyed, and that the land and turnips may be kept more dry during wet weather and the months of winter. This concludes the culture of the turnip, which now grows rapidly without further care; and by the beginning of September the leaves of a good crop will have covered the entire surface, making a transverse section of the ridges appear thus: (fig. 765.)



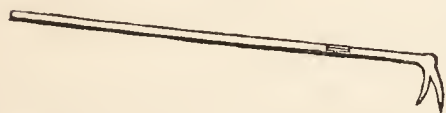
5409. The Swedish turnip is cultivated, used, and stored precisely in the same manner as the common turnip; but it is generally sown several weeks earlier. It does not attain to the same weight by the acre; and, as it is more difficult to raise, it ought to receive a greater quantity of manure, and to be always upon good land. The Swedish has a property which the common turnip has not, that of bearing to be transplanted

when young; so that, where blanks appear in a field, the spaces may be filled up by transplanting. Analogous to the Swedish turnip, in hardness and nutritive qualities, is the large yellow or Aberdeen turnip. This root is perhaps superior to the Swedish turnip, in so far as it may be raised with less difficulty. It serves the same purpose of a succedaneum to the common turnip in spring.

5410. *Consumption of the turnips.* By the end of October or beginning of November, when the pastures have decayed, the turnips begin to be used for food.

5411. *When sheep are to be fed,* the turnips are either pulled up by the hand, and carried away, as wanted, into the fields, in which the sheep are kept, and there spread regularly upon the ground; or more frequently and economically the sheep are at once driven into the fields of turnips, and suffered to consume the roots as they stand. In this case the animals are not suffered to range over the whole field at first, but are confined to a space of an acre or more, by means of nets, or a series of moveable rails or hurdles. When the sheep have eaten the roots very nearly, the remnant in the ground may be picked up by a little hoe (*fig. 766.*) or by the turnip chopper already described (2572.); and when the whole are consumed, the nets or rails, or hurdles, are moved to another division, and so on throughout the field, leaving the spaces before cleared open to the sheep to move upon. This manner of consuming the turnips affords an admirable manure to the land, and prepares it well for the subsequent crops of grain and herbage. In feeding in this manner, it is frequent to place in the field a little rack with a cover, containing a small quantity of hay, which seems

766



to be relished by the animals amid their moister food.

5412. *In the feeding of oxen,* the turnips may be laid down on a dry field, as in the case first mentioned; but the proper and regular manner of feeding these animals is to supply them with the turnip in the house or open yard, littering them at the same time plentifully and regularly with straw, and giving them what they choose to consume of it as provender, with their turnip-food. Cattle are fed either by being tied to upright posts in the house, or they are suffered to go at large in the straw-yard. This last is greatly the better mode of feeding, the turnips being supplied from troughs or otherwise, and a shed for shelter being always at hand and open to the cattle to repose in. It is well, however, that too many animals, of different strength and size, be not put together, lest they disturb each other in feeding. Sometimes courts are made and divided into separate compartments, holding only two cattle in each, and this is found to be an exceedingly good practice. When cattle are of value, and put up for quick fattening, it is common to cut off the leaves and tails of the turnip, giving the leaves to the younger and less valuable stock, and the bulb only to that which is to be fed.

5413. *Young cattle,* not intended to be immediately fattened, receive only a limited portion of turnips, their principal provender being straw. By receiving a portion of turnips with their drier provender, these animals are kept in a much more healthy condition than if confined to the latter food, and continue to grow throughout the whole season, instead of pining away at the time when green herbage can no longer be found for them. With the design, too, of keeping them in a good condition, turnips are supplied in a limited quantity to milch cows, and in particular at the time of calving. The turnip, however, though it adds to the quantity of milk, gives it a strong and disagreeable flavour.

5414. *When both sheep and cattle are fed* upon a farm, it is usual to pull up every alternate four or five rows of turnips for the cattle, leaving the remainder on the ground for the sheep, so that the land on which the turnips had grown may receive its proportion of the manure produced. (*Quar. Jour. Ag.* vol. i. p. 286.)

5415. *The advantages of eating turnips on the place of their growth by sheep,* both in manuring and consolidating the ground, are sufficiently well known to every farmer. One great defect of the inferior sort of turnip soil is the want of tenacity; and it is found that valuable crops of wheat may be obtained upon very light porous soils, after turnips so consumed. It is not uncommon to let turnips at an agreed price, for each sheep or beast, weekly. This varies according to age and size, and the state of the demand, from four-pence or less, to eight-pence or more, for each sheep weekly, and from two shillings to five for each beast. An acre of good turnips, say thirty tons, with straw, will fatten an ox of sixty stone, or ten Leicester sheep. Supposing the turnips worth six guineas, this may bring the weekly keep of the ox to six shillings and three-pence halfpenny, and of the sheep to about seven-pence halfpenny a week. In this way of letting, however, disputes may arise, as the taker may not be careful to have them eaten up clean. The person who lets the turnips has to maintain a herd for the taker; and when let for cattle, and consequently to be carried off, the taker finds a man and horse, and the letter maintains both. The taker has to provide hurdles or nets for fencing the allotments to sheep; but the letter must fence his own hedges if necessary. The period at which the taker is to consume the whole is usually fixed in the agreement, that the seller may be enabled to plough and sow his land in proper season. (*Suppl. to Encyc. Brit.*) The rule for selling turnips in Norfolk is calculated from the fact, that *one acre of good turnips is sufficient for 100 sheep for one week.* Then, whether turnips be dear or cheap, the price per week may be easily found — at 5*l.* per acre, 1*s.* per week per head, and so of all other prices. This is under the supposition that the crop is to be eaten off on the ground.

5416. *The Swedish and yellow turnips* are eaten greedily by horses; and afford a very nutritive and salutary food along with hay or straw for working stock. The best mode is to steam them after previously passing them through the slicing machine, as no root requires so much cooking as the Swedish turnip. Horses will also eat the white turnip, but not freely, unless they have been early accustomed to them, as in some parts of Norfolk.

5417. *Cattle fatten much faster with clean turnips* than with such as are dirty, and therefore Waistell recommends that they should never be given without being previously washed. "The earth upon unwashed turnips," he says, "scours the cattle, and keeps their bodies too loose and open; their dung being thin and almost liquid, carries off with it a white mucous matter from the bowels, which is frequently seen among the dung, the loss of which must necessarily retard the fattening of the cattle; but with washed turnips their dung is wax-like, and figured similarly to the dung of cattle fed on rich meadow hay. Cisterns are also found very useful in frosty weather; for when frozen turnips are thrown into spring water, it speedily draws out of them all the icy particles, which, when retained, must undoubtedly render them much less nourishing and improving to the cattle that eat them." (*Waistell's Designs*, &c. p. 40.)

5418. *Near large towns* the most profitable mode of disposing of turnips is to the cow-keepers and green-grocers.

5419. *The application of turnips in domestic economy* is well known. They may also be used in the distillery; and a wine is said to be made from them by the London manufacturers of imitations of foreign wine.

5420. *The storing of turnips* is attended with too much labour and risk to be of much advantage in the greater part of the kingdom. Common turnips are never stored in any great quantity, though sometimes a portion is drawn and formed into heaps, like

potato camps, and lightly covered with straw, or preserved for some time under a shed. On these occasions, before storing up, the shaws or leaves and the tap-roots must be cut off and removed, to prevent heating and rotting. The heaps must not be covered with earth-like potatoes, for in this case their complete destruction is inevitable. This root contains too much water to be preserved for any length of time in a fresh and palatable state, after being removed from the ground; and though the loss in seasons unusually severe, particularly in the *white globe* variety, is commonly very great, it is probable that a regular system of storing the whole, or the greater part, of the crop every season would, upon an average of years, be attended with still greater loss; besides the labour and expense, where turnips are cultivated extensively, would be intolerable. (*Supp. &c.*)

5421. *Taking up and replacing* is a mode by which turnips have been preserved, by Blaikie of Holkham, and some others. The mode is to cart the turnips from the field where they grow, to a piece of ground near the farm-offices, before the winter rains set in, when, the tap-root being cut off, the plants are set on the surface of the ground, in an upright position, as close to each other as they can stand, where they keep much better than in a store during the whole season. The advantages of having them quite close to the homestead, in place of bringing them most probably from a distant part of the farm in wet or stormy weather, are so obvious, as fully to justify a recommendation of the practice.

5422. *Replating and earthing* have also been tried with success, especially with the Swedish turnip. Being pulled and freed from their roots and leaves, they are carted to a piece of well worked dry soil near the farmery, and there deposited in rows, so close as nearly to touch each other in the bottom of shallow furrows, the plough covering one row as another furrow is opened. In this way many tons are quickly earthed in, and on a very small space, and they can be turned out when wanted with equal facility. (*Farmer's Magazine*, vol. xxiii. p. 282.)

5423. *The produce of turnips* cultivated in the broad-cast manner in England varies from five to fifteen tons per acre: the latter is reckoned a very heavy crop. In Northumberland and Berwickshire, a good crop of white globe turnips drilled usually weighs from twenty-five to thirty tons per acre, the yellow and Swedish commonly a few tons less. Of late there have been instances of much heavier crops, and in Ayrshire it would appear that above sixty tons have been raised on an English acre, the leaves not included. (*Farmer's Magazine*, vols. xv. and xvi.) But such an extraordinary produce must have been obtained by the application of more manure than can be provided, without injustice to other crops, from the home resources of a farm; and where turnips form a regular crop in the rotation, no such produce is to be expected under any mode of culture.

5424. *The produce of the turnip in nutritive matter*, as proved by Sir H. Davy, was forty-two parts in a thousand; of which seven were mucilage, thirty-four sugar, and one gluten. Swedish turnips afforded sixty-four parts in a thousand of nutritive matter, of which nine were starch, fifty-one sugar, two gluten, and two extract. According to Von Thaer, 100 lbs. of turnips are equal to twenty-two of hay; and an ox to get fat on turnips ought to have one third of its weight daily.

5425. *To raise turnip seed*, the usual mode is to select the most approved specimens of the variety to be raised at the season when they are full grown; and either to remove all others from the field and leave them to shoot into flower stems next year, or to transplant them to a place by themselves, where they will be secure from the farina of other plants of their genus. In either case they must be protected by earthing up from the winter's frost and rains, and in the ripening season from the birds.

5426. *The true sort of Swedish turnip* can very easily be kept by only attending to the plants when in flower. All the degenerated ones bear bright yellow flowers, which should be pulled out before the seed ripens. The true sort have a *brownish* yellow flower. This saves the expense of transplanting if a corner or one ridge of a field can be found convenient for saving.

5427. *The Norfolk seed-growers* have a sort of theory on the subject of transplanting turnips for seed which it may be worth while to attend to. According to that theory, where turnip seed is collected from such turnips as have been sown three or four years in succession, the roots are liable to be numerous and long, and the necks or parts between the bulbs and leaves coarse and thick: and when taken from such as have been transplanted every year, these parts are liable to become too fine, and the tap-roots to be diminished in too great a proportion. Of course the most certain plan is to procure seed from turnips that are transplanted one year and sown the next; or, if they be transplanted once in three years, it is supposed, that the stock may be preserved in a proper state of perfection. It is stated, that the method of performing this business in the best way, is to select such turnips as are of the best kinds and of the most perfect forms from the field crops, and after cutting their tops off, to transplant them, about the month of November, or following month, into a piece of ground that has been put into a fine state of tillage by repeated ploughing or digging over, and which should be situated as near the house as it can be, in order that the birds may be better kept from it. The seed will mostly be ready for gathering in the end of July, or in the following month.

5428. *Others cultivators*, however, advise that the seed collected from a few turnips thus transplanted should be preserved and sown in drills, in order to raise plants for seed for the general crop, drawing out all such as are weak and improper, leaving only those that are strong and which take the lead; and that when these have formed bulbs, such as do not appear good and perfect should be taken out, as by this means turnip seed may be procured, not only of a more vigorous nature, but capable of vegetating with less moisture, and of producing stronger and more hardy plants. The practice of transplanting the whole of the turnips for seed for the main crops, they contend, is not only highly expensive, but injurious, by diminishing the strength of the plants from the destruction of their tap-roots. Very good seed may, however, be raised in either of the methods that have been here described.

5429. *The best Norfolk turnip-seed growers* are of opinion that unless the seed be *always* saved from transplanted roots, the stock will infallibly degenerate in the manner here described. The statement that transplanting once in three years is sufficient, was a mere pretence with some of the growers to enable them to save two thirds of the heavy expense which attends transplanting turnips, and to get the same price for their seed as if it had been properly saved. The only exception to this is in what the Norfolk farmers call the "pudding" or "long pudding" turnip, which is too tender to bear the winter. For a *stock*, a few sorts are taken up and protected from cold like mangold wurzel; and for a general crop the

seed is sown broadcast and not hoed, but suffered to grow like *rape*. So treated the plants form very small woody sorts, which are capable of enduring frosts. (*J. L.*)

5430. *After the seed has become fully ripened*, it is mostly reaped by cutting off part of the stems, and afterwards tying them up into sheaves, which, when sufficiently dry, are put into long stacks, and kept through the winter, in order to be threshed out about the time when it is wanted. But as in this way much seed is liable to be lost, by its readiness to escape from the pods in which it is contained, it is advised, as a much better practice, to have it immediately threshed out, either upon a cloth in the field where it grew, or in some other convenient place, being then put into bags proper for the purpose and placed in a situation which is perfectly dry. From seed crops of this sort being subject to much injury, and loss in different ways, the quantity of produce must be very different under different circumstances; but it may in general be stated at not less than from twenty to twenty-four bushels the acre. The price of turnip seed being seldom less than seven or eight shillings the bushel, on account of the great demand for it, it may at first appear to be a very advantageous sort of culture; but from the exhausting nature of the crop, the loss sustained in grain, and the quantity of manure afterwards necessary, it is probable that turnip seed can only be grown to advantage in particular circumstances of soil and situation. In most cases it is, however, well for the farmer to raise his own seed, as that of the shops is seldom to be fully depended upon.

5431. *The diseases and injuries to which turnips are liable* are various. At their first appearance their leaves are liable to the attacks of the fly (*Aphis* and *Háltica*,) the caterpillar, the slug, and the mildew. Their bulbs and roots are attacked by worms of different kinds; by a singular tendency to monstrosity, known provincially by the name of fingers and toes; by the anbury; by canker, and by wasting or gangrene from water or frost. Of all or most of these injurious diseases it may be observed, that they neither admit of prevention or cure by art. Under favourable circumstances of soil, climate, culture, and weather, they seldom occur; therefore all that the cultivator can do is to prepare and manure his land properly, and in the sowing season supply water when the weather is deficient in showers or the soil in humidity.

5432. *The fly* attacks the turnip when in the seed-leaf, and either totally devours it, or partially eats the leaves and centre-bud, so as to impede the progress of the plants to the second or rough leaves. Whether the eggs of these flies are deposited on the plants or in the soil, does not appear to be ascertained; in all probability they are attached to the former, as in the gooseberry caterpillar, and most cases of flies and insects which feed on plants. Preparations and mixtures of the seed, as already treated of, are all that have yet been done in the way of preventive to this evil.

5433. *The caterpillar* makes its appearance after the plants have produced three or more rough leaves; these they eat through, and either destroy or greatly impede the progress of the plants. There can be little doubt that the eggs of these caterpillars are deposited on the leaves of the plants by a species of moth, as the caterpillar may be detected when not larger in diameter than a hair. As preventives to the moths from fixing on the turnips for a depository for their eggs, it has been proposed to place vessels with tar in different parts of the field, the smell of which is known to be very offensive to moths and all insects; or to cause a thick offensive smoke from straw or weeds to pass over the ground at the time when it is supposed the moths or parent flies were about to commence their operations. To destroy the caterpillar itself, watering with tobacco water, lime water, strong brine, and laying on ashes, barley awns, &c. have been proposed.

5434. *The slug and snail* attack the plants both above and under ground, and eat both the leaves and roots. Rolling, soot, quicklime, awns, &c. have been proposed to annoy them; but the only effectual mode is, immediately after the turnips are sown, to strew the ground with cabbage leaves, or leaves of any of the *Brássica* tribe. On these, especially if sweet from incipient decay, the slugs will pasture, and may be gathered off by women or children every morning. If as many cabbage leaves, or handfuls of decaying pea haulm, or any similar vegetable be procured, as will go over a ridge or two, say at the rate of a leaf to every square yard, a whole field may soon be cleared by picking off the slugs and removing the leaves once in twenty-four hours. This mode we have found most effectual, and it is extensively practised by market and other gardeners. (*Encyc. of Gard.* 2275.)

5435. *The mildew* and blight attack the turnip in different stages of its progress, and always retard its growth. Its effects may be palliated by watering and strewing the leaves with sulphur; but this will hardly be considered applicable to whole fields.

5436. *The worms attack the roots*; and, when they commence their ravages at an early period, impede their growth, and ruin or greatly injure the crop. They admit of no remedy or prevention.

5437. *The forked excrescences*, known as fingers and toes in some places, and as the anbury in others, are considered an alarming disease, and hitherto it can neither be guarded against nor cured. The following account of it is given by William Spence, president of the Holderness Agricultural Society in 1811:—

5438. *In some plants, the bulb itself is split into several finger like-diverging lobes*. More frequently the bulb is externally tolerably perfect, and the tap-root is the part principally diseased; being either wholly metamorphosed into a sort of misshapen secondary bulb, often larger than the real bulb, and closely attached to it, or having excrescences of various shapes, frequently not unlike human toes (whence the name of the disease), either springing immediately from its sides, or from the fibrous roots that issue from it. In this last case, each fibre often swells into several knobs, so as distantly to resemble the runners and accompanying tubers of a potato; and not seldom one turnip will exhibit a combination of all these different forms of the disease. These distortions manifest themselves at a very early stage of the turnip's growth; and plants, scarcely in the rough leaf, will exhibit excrescences, which differ in nothing else than size from those of the full-grown root.

5439. *The leaves discover no unusual appearance*, except that in hot weather they become flaccid and droop; from which symptom the presence of the disease may be surmised without examining the roots. These continue to grow for some months, but without attaining any considerable size, the excrescences enlarging at the same time. If divided at this period with a knife, both the bulb and the excrescences are found to be perfectly solid, and internally to differ little in appearance from a healthy root, except that they are of a more mealy and less compact consistency, and are interspersed with more numerous and larger sap-vessels. The taste, too, is more acrid; and, on this account, sheep neglect the diseased plants. Towards the approach of autumn, the roots, in proportion as they are more or less diseased, become gangrenous and rot, and are either broken (as frequently happens) by high winds, or gradually dissolved by the rain. Some, which have been partially diseased, survive the winter; but of the rest, at this period, no other vestige remains than the vacant patches which they occupied at their first appearance. There is no longer any doubt about the cause of this disease; it is the effect of the deposition of the eggs of a small fly (probably a *Scarabæus*) into the pithy parts of the roots, and the alburnous parts of the bulb, which soon changing to a maggot, and ultimately to a perfect insect, eat their way out.

5440. *For the prevention of this disease*, marl has been recommended by Sir Joseph Banks and others; and where marl cannot be procured, it has been thought that an addition of mould of any kind, that has not borne turnips, will be advantageous; such as a dressing taken from banks, woodlands, ditches, &c. and mixed up with a good dose of lime. But lime alone has been tried in vain; and no great dependence

can be placed upon fresh mould, as this disease has been known to prevail upon lands that had scarcely ever before borne a crop of turnips (*Farmer's Magazine*, vol. xiii.). The only effectual preventive would be to hinder the insect from laying its eggs.

5441. *The canker* attacks the roots, and partly the bulbs, of turnips, and is known by the ulcerated appearance it produces. Some consider it owing to the presence of too much iron in the soil, and recommend liming as a preventive.

5442. *Wasting and putrefaction*, from excess of water or frost, are to be prevented by earthing up the bulbs, or taking up and storing.

SECT. III. *The Carrot.* — *Daucus Carota* L. ; *Pentándria Digýnia* L., and *Umbelliferae* J. *Carotte*, Fr. ; *Gelbe Rube*, Ger. ; *Carota*, Ital. ; and *Chirivia*, Span.

5443. *The carrot* is a biennial plant, a native of Britain ; but though long known as a garden plant, it is comparatively but of recent introduction in agriculture. It appears to have been cultivated from an early period in Germany and Flanders, and introduced from the latter country to Kent and Suffolk early in the 16th century. As the carrot requires a deep soil, inclining to sand, it can never enter so generally into cultivation as the potato or turnip ; but, as observed by a judicious writer, it has been too much neglected on lands where it would have yielded a more valuable product, perhaps, than any bulbous or tap-rooted plant whatever. Several contradictory experiments in its culture have been detailed in a number of publications, from which the practical husbandman will be at a loss to draw any definite conclusion : but, in a recent communication to the Board of Agriculture, from Robert Burrows, an intelligent Norfolk farmer, who has cultivated carrots on a large scale, and with great success, for several years, so accurate an account is presented of the culture, application, and extraordinary value of this root, that carrots will probably soon enter more largely into the rotation of crops on suitable soils. (*Supp. &c.*) This person had more experience than any one ; but he, after a few years, discontinued to cultivate carrots so extensively as he did at the time the communication to the Board of Agriculture was made. The consumption of carrot seed in Norfolk had, in 1821, diminished from three or four tons a year to as many cwts.

5444. *The varieties of carrot* cultivated in gardens are numerous, and readily increased by the usual means ; but the only sort adapted for the field is the long red or field carrot. New seed is most essential, as it will not vegetate in the second year. Old seed, or a mixture of old and new, and also the mixture of the horn carrot, the seed of which is sent over in large quantities from Holland, ought to be carefully avoided.

5445. *The best soil for the carrot* is a deep rich sandy loam ; such a soil ought at least to be a foot deep, and all equally good from top to bottom. On any other the field culture of the carrot will not answer.

5446. *In preparing the soil for the carrot*, it is essential to plough it before winter, that it may be pulverised by frost ; and to work it well by the plough and cultivator in spring, to at least the depth of a foot. This deep tillage may be perfectly accomplished either by means of the trench-plough following the common one, or by the common one alone, with a good strength of team ; but the former method is to be preferred, wherever the lands are inclined to be stiff or heavy. Three ploughings are mostly found sufficient, where the land has been previously in a state of tillage ; but more may in other cases be necessary. The first ploughing should be made to the depth of ten, twelve, or fourteen inches, and be performed when the soil is tolerably dry, about the beginning of October. It may remain in this condition till towards the middle of February, when it should be turned over a second time, but in a cross direction, to nearly the same depths. In March a third ploughing may be given, in order to the putting in of the seed. This may be somewhat lighter than the preceding ones. As soon as the last ploughing has been given in March, the land should be harrowed, and the surface made as fine as possible.

5447. *In Suffolk the farmers sow carrots after turnips*, barley, and peas set upon a ryegrass ley ; the crops upon the first have generally been most productive ; next to that they prefer the latter. In the first place, they feed off the turnips by the beginning of February, and then lay the land up in small balks or furrows, in which state it remains till the second week in March, when it is harrowed down, double furrowed to the depth of about twelve inches, and the seed sown.

5448. *The climate* most suitable to the carrot is the same as for the turnip ; but, from the depth to which their roots penetrate, they will thrive better than the turnip in a dry and warm climate.

5449. *Manure*, according to some, should not be given to carrots the year they are sown, as it is alleged that when the roots meet with it they become forked, scabbed, and wormy. This, however, is chiefly applicable to cases in which recent unfermented manure has been given, or where other manure has not been properly broken in pieces and spread over the soil or in the drills. The Suffolk and Norfolk farmers, who are the best carrot-growers, always use dung ; a suitable proportion of well rotted farmyard dung being constantly turned into the soil at the last ploughing in March : for it has been fully shown, by various trials detailed in *The Annals of Agriculture* and other books on husbandry, that though good crops of carrots may be occasionally grown without the use of manure, it is only by the liberal application of that substance that the greatest produce possible can be obtained ; as they are in general found to bear a relative proportion to the quantity that may have been employed.

5450. *Burrows* prepares the land with a good dressing of about sixteen cart-loads per acre of rotten farmyard manure or cottager's ashes : the load is about as much as three able horses can draw ; and, if bought, costs about four shillings and sixpence per load, besides the carting on the land. He usually sows

wheat stubbles after clover, ploughing the first time in autumn, and once more in the early part of the month of February, if the weather permits; setting on the manure at the time of sowing, which is about the last week in March, or sometimes as late as the second week in April.

5451. *In Suffolk, when carrots are intended to be sown after peas, they usually plough the stubble as soon as the harvest is over, in order that the land may clear itself of weeds; in December it is laid up in small balks, to receive the benefit of the frosts; in February it is harrowed down, and manured at the rate of fifteen loads per acre; the manure is ploughed in to the depth of about four inches; and in the month of March the land is double furrowed, and the seed sown. By pursuing this method, they say, the manure lies in the centre of the soil, and not only affords nourishment and support to the carrot in its perpendicular progress, but renders it easy to be turned up by a single ploughing, and greatly promotes the growth of the succeeding crop of barley. In Norfolk it is the practice to sow carrots after a crop of turnips. The manure, after being put on the land in the beginning of March, is first ploughed in with a common plough, and afterwards trench-ploughed about fourteen or fifteen inches deep; it is then harrowed very fine, and the seed sown about the middle of March.*

5452. *The season preferred by Burrows for sowing the carrot is the last week in March or first in April; but he prefers the first period, having generally found early-sown crops the most productive.*

5453. *The usual preparation of the seed for sowing, is mixing it with earth or sand, to cause it to separate more freely; but Burrows adds water, turns over the mixture of seeds and moist earth several times, and thus brings it to the point of vegetating before he sows it. "Having weighed the quantity of seed to be sown, and collected sand or fine mould, in the proportion of about two bushels to an acre, I mix the seed with the sand or mould, eight or ten pounds to every two bushels, and this is done about a fortnight or three weeks before the time I intend sowing; taking care to have the heaps turned over every day, sprinkling the outside of them with water each time of turning over, that every part of the sand heaps may be equally moist, and that vegetation may take place alike throughout. I have great advantage in preparing the seed so long beforehand; it is by this means in a state of forward vegetation, therefore lies but a short time in the ground, and, by quickly appearing above ground, is more able to contend with those numerous tribes of weeds in the soil, whose seeds are of quicker vegetation." (Supp. &c.)*

5454. *Crude, the French translator of Von Thacr's work, describes in a note (tom. iv. 237.) a practice nearly similar to that of Burrows. Crude uses sciure (night soil) instead of earth, and waters with the drainings of dunghills. He keeps the mixture in a warm but shady situation for eight days; by that time the seed is nearly ready to vegetate, and he sows it immediately.*

5455. *The quantity of seed when carrots are sown in rows is two pounds per acre, and for broad-cast sowing five pounds. Burrows sows ten pounds per acre in the broad-cast manner.*

5456. *The usual mode of sowing the carrot is broad-cast; but a much better mode in our opinion would be to sow them in rows at twelve or fourteen inches' distance; drawing the drills, and hoeing the intervals with any suitable drill and hoe.*

5457. *The most common practice, when carrots are best cultivated, is the hand or broad-cast method, the seed being dispersed as evenly as possible over the land, after the surface has been reduced to a very fine state of pulverisation by harrowing, in order to provide a suitable bed for it to vegetate in; being then covered in by means of a light harrow. As the seed of the carrot is not of a nature to be deposited with much regularity by the drill, and as the young plants can be easily set out to proper distances in the operation of hoeing, this is probably the most appropriate method of putting such sort of seed into the ground; and an additional proof of it is indeed found in its being that which is almost universally adopted in those districts where carrot-husbandry is practised to the greatest extent. But with the view of having the after-culture of the crops more perfectly performed, and at the same time to save the great expense of hand-labour in hoeing the crop, the drill method has been attempted by some cultivators, but we believe without complete success. The work is finished in equidistant rows at the distance of from twelve to fifteen or eighteen inches from each other, according to the mode of hoeing that is practised. In this business some cultivators do not make use of drill-machines, but strike the land into small furrows by hoes or other implements contrived for the purpose, and then cast the seed over the ground by the hand, covering it in either by slight harrowing, or hoeing in the tops of the ridgelets. It is added, that "in this method, where a drill-machine is used, it has been advised by an intelligent cultivator to deposit the seed to the depth of one inch in the rows, leaving the spaces of fourteen inches between them as intervals; the seed in these cases being previously steeped in rain-water for twenty-four hours, and left to sprout, after which it is mixed with saw-dust and dry mould, in the proportion of one peck and a half of each to a pound of the seed. The land is afterwards lightly harrowed over once. Two pounds of seed in this mode are found, as it has been observed, sufficient for an acre of land."*

5458. *The after-culture given the carrot consists entirely of hoeing and weeding.*

5459. *In Suffolk they are hoed generally three times in the season. The first time, as soon as the plants can be distinguished from the weeds which surround them. The operation should be performed with three-inch hoes, having handles not above two feet in length; and it requires great attention, as it is extremely difficult to distinguish and separate the young carrots from the weeds. The second hoeing should be given in three or four weeks afterwards, according to the forwardness of the crop; it may be performed with common hoes, care being taken to set out the plants at proper distances. From eight to fifteen or eighteen inches, each way, are the common distances at which they are allowed to stand; and it has been proved, from many years' experience in districts where they are most cultivated, that carrots which grow at such distances always proves a more abundant crop than when the plants are allowed to stand closer together. The third hoeing is commonly given about the middle or end of June; and in this, besides destroying the weeds, another material circumstance to be attended to is, to set out the carrots at proper distances, and also, wherever any have been left double at the former hoeings, to take the worse of the two plants away.*

5460. *Carrots sown according to the plan of Burrows are ready to hoe within about five or six weeks. He hoes three and sometimes four times, or until the crop is perfectly clean: the first hoeing is with hoes four inches long, and two and a quarter inches wide. The second hoeing invariably takes place as soon as the first is completed, and is performed with six-inch hoes, by two and a quarter inches wide. By this time the plants are set; the first time of hoeing nothing was cut but the weeds. He leaves the plants nine inches apart from each other; sometimes they will be a foot, or even farther asunder.*

5461. *Carrots are taken up generally in the last week of October.* Burrows's practice is to let the work to a man who engages women and children to assist him. The work is performed with three-pronged forks; the children cut off the tops, laying them and the roots in separate heaps, ready for the teams to take away.

5462. "*I take up in autumn a sufficient quantity to have a store to last me out any considerable frost or snow that may happen in the winter months; the rest of the crop I leave in the ground, preferring them fresh out of the earth for both horses and bullocks. The carrots keep best in the ground, nor can the severest frosts do them any material injury; the first week in March it is necessary to have the remaining part of the crop taken up, and the land cleared for barley. The carrots can either be laid in a heap with a small quantity of straw over them, or they may be laid into some empty outhouse or barn, in heaps of many hundred bushels, provided they are put together dry. This latter circumstance it is indispensably necessary to attend to; for if laid together in large heaps when wet, they will certainly sustain much injury. When selecting such as I want to keep for the use of my horses until the months of May and June, in drawing over the heaps (which should be done in the latter end of April, when the carrots begin to sprout at the crown very fast) I throw aside the healthy and most perfect roots, and have their crowns cut completely off and laid by themselves; by this means, carrots may be kept the month of June out in a high state of perfection.*" (*Communications to the Board of Agriculture*, vol. vii. p. 72.)

5463. *Storing a whole crop of carrots may be a desirable practice when winter wheat is to follow them, in which case the same mode may be adopted as for turnips or potatoes, but with fewer precautions against the frost, as the carrot, if perfectly dry, is very little injured by that description of weather.*

5464. *The produce of an acre of carrots in Suffolk, according to Arthur Young, is at an average 350 bushels; but Burrows's crops averaged upwards of 800 bushels per acre, which considerably exceeds the largest crop of potatoes.*

5465. *The uses to which the carrot is applied in Suffolk are various. Large quantities are sent to the London markets, and also given as food to different kinds of live stock. Horses are remarkably fond of carrots; and it is even said, that when oats and carrots are given together, the horses leave the oats and eat the carrots. The ordinary allowance is about forty or fifty pounds a day to each horse. Carrots when mixed with chaff, that is, cut straw, and a little hay, without corn, keep horses in excellent condition for performing all kinds of ordinary labour. The farmers begin to feed their horses with carrots in December, and continue to give them chiefly that kind of provender till the beginning or middle of May; to which period, with proper care, carrots may be preserved. As many of the farmers in that country are of opinion that carrots are not so good for horses in winter as in spring, they give only half the above allowance of carrots at first, and add a little corn for a few weeks after they begin to use carrots.*

5466. *The application of the carrot to the feeding of working cattle and hogs is thus detailed by Burrows:— "I begin to take up the carrot crop in the last week of October, as at that time I generally finish soiling my horses with lucern, and now solely depend upon my carrots, with a proper allowance of hay, as winter food for my horses, until about the first week of June following, when the lucern is again ready for soiling. By reducing this practice to a system, I have been enabled to feed ten cart-horses throughout the winter months for these last six years, without giving them any corn whatever, and have at the same time effected a considerable saving of hay, from what I found necessary to give to the same number of horses, when, according to the usual custom of the country, I fed my horses with corn and hay. I give them to my cart-horses in the proportion of seventy pounds' weight of carrots a horse per day, upon an average; not allowing them quite so many in the very short days, and sometimes more than that quantity in the spring months, or to the amount of what I withheld in the short winter days. The men who tend the horses slice some of the carrots in the cut chaff or hay, and barn-door refuse; the rest of the carrots they give whole to the horses at night, with a small quantity of hay in their racks; and with this food my horses generally enjoy uninterrupted health. I mention this, as I believe that some persons think that carrots *only*, given as food to horses, are injurious to their constitutions; but most of the prejudices of mankind have no better foundation, and are taken up at random, or inherited from their grandfathers. So successful have I been with carrots, as a winter food for horses, that with the assistance of lucern for soiling in summer, I have been enabled to prove by experiments conducted under my own personal inspection, that an able Norfolk team-horse, fully worked two journeys a day, winter and summer, may be kept the entire year round upon the produce of only one statute acre of land. I have likewise applied carrots with great profit to the feeding of hogs in winter, and by that means have made my straw into a most excellent manure, without the aid of neat cattle; the hogs so fed are sold on Norwich hill to the London dealers as porkers." The profit of carrots so applied he shows in a subsequent statement, together with an experiment of feeding four Galloway bullocks with carrots, against four others fed in the common way with turnips and hay. (*Communications, &c.*)*

5467. *In comparing the carrot with the potato, an additional circumstance greatly in favour of the former is, that it does not require to be steamed or boiled, and it is not more difficult to wash than the potato. These and other circumstances considered, it appears to be the most valuable of all roots for working horses.*

5468. *The use of the carrot in domestic economy is well known. Their produce of nutritive matter, as ascertained by Sir H. Davy, amounts to ninety-eight parts in one thousand, of which three are starch, and ninety-five sugar. They are used in the dairy in winter and spring to give colour and flavour to butter. In the distillery, owing to the great proportion of sugar in their composition, they yield more spirit than the potato: the usual quantity is twelve gallons per ton. They are excellent in soups, stews, and haricots, and boiled whole with salt beef.*

5469. *To save carrot seed, select annually some of the most perfect and best-shaped roots in the taking-up season, and either preserve them in sand in a cellar till spring, or plant them immediately in an open airy part of the garden, protecting them with litter during severe frosts, or earthing them over, and uncovering them in March following. The seed is in no danger of being contaminated by any other plant, as the wild carrot, even should it happen to grow in the neighbourhood, flowers later. In August it will be fit to gather, and is best preserved on the stalks till wanted. This is the most*

certain mode of procuring genuine and new seed, but still it will be found advisable to change it occasionally.

5470. *The diseases of carrots* are only those which are common to most plants, such as mildew, insects, &c. The mildew and worms at the root frequently injure crops, and are to be guarded against as far as practicable by a proper choice of soil, season of sowing, and after-culture.

SECT. IV. *The Parsnep.* — *Pastinaca sativa* L.; *Pentándria Digýnia* L., and *Umbelíferæ* J. *Le Panais*, Fr.; *Pastinake*, Ger.; *Pastinaca*, Ital.; and *Zanahoria*, Span.

5471. *The parsnep* is a biennial plant with a fusiform root like the carrot, and nearly equal in its products of nutritive and saccharine matter. It is a native of most parts of Europe and generally cultivated in gardens, but is only of late and very partial introduction as a field plant. Its culture has been chiefly confined to the Island of Jersey, where it attains a large size, and is much esteemed for fattening cattle and pigs. It is considered rather more hardy than the carrot, and its produce is said to be greater. It may be sown either in autumn or spring, and its seed admits of drilling by machinery. The plants when they come up are more easily recognised than carrots, and consequently their culture is on the whole more simple, less dependent on manual labour, and, therefore, more suited to farming. For the rest, their culture is the same as that of the carrot.

5472. *The variety* best suited for the field is the large Jersey, the seed of which should be procured from the island, as that of the garden parsnep sold by the seedsmen never attains the same size.

5473. *The soil, preparation, and manure* for this plant are the same as for the carrot.

5474. *The quantity of seed* for sowing in drills is from four to five pounds per acre, and for broad-cast six or eight pounds. It must always be new, as two years' seed does not come up freely. It may or may not be prepared by steeping; but it requires no earth or sand, or rubbing, like carrot seed, as it passes freely through the same drill that will sow tares or peas.

5475. *The time of sowing* is generally about the middle of February; but some sow in September, in which case the seed does not vegetate till early in spring. The latter method, however, is obviously against the culture of the soil, which must thus remain a year in a consolidated state.

5476. *The manner of sowing* is generally in drills at fifteen or eighteen inches' distance; but some sow broad-cast, and harrow in the seed; and in Jersey parsneps and beans are generally cultivated together. The beans are first dibbled in, and afterwards the parsnep seed scattered over the surface and harrowed. It is acknowledged that a good crop of both plants is never obtained; and therefore, though this mode may be found to answer in the mild climate of Jersey, it is not to be imitated in other places. Drills and broad-cast without any intermixture of plants are the only advisable modes.

5477. *The after-culture and taking up* are the same as for the carrot, with this difference, that the parsnep when sown broad-cast is generally thinned out to twelve inches, at an average, plant from plant; and, when in rows eighteen inches apart, to nine inches in the row.

5478. *The produce* is said to be greater than that of carrots; and the economical application the same. In the fattening of cattle it is found equal if not superior, performing the business with as much expedition, and affording meat of exquisite flavour and a highly juicy quality. The animals eat it with much greediness. It is reckoned that thirty perches, where the crop is good, will be sufficient to fatten a perfectly lean ox of three or four years old, in the course of three months. They are given in the proportion of about thirty pounds' weight morning, noon, and night; the large ones being split in three or four pieces, and a little hay supplied in the intervals of those periods. Indeed, the result of experiment has shown that not only neat cattle, but hogs and poultry, become fat much sooner, and are more bulky, than when fed with any other root or vegetable; and that the meat is more sweet and delicate. The parsnep is excellent food for cows; and, with hay during winter, the cows of Jersey and Guernsey yield butter of a fine yellow hue, of a saffron tinge, as excellent as if they had been in the most luxuriant pasture. In these islands beans are cultivated along with parsneps, in double rows, twelve feet asunder, and the beans eighteen inches apart every way. The beans are planted first, and the ground afterwards harrowed, and the parsneps sown broad-cast. (*Com. to B. of Agr.* vol. i. p. 215.)

5479. *Parsnep leaves*, being more bulky than those of carrots, may be mown off before taking up the roots, and given to cows, oxen, or horses, by which they will be greedily eaten.

5480. *The use of the parsnep in domestic economy* is nearly the same as that of the carrot. They are much esteemed to salt fish, and are sometimes roasted for that purpose.

Their produce in nutritive matter is 99 parts in 1000, of which 9 are mucilage and 90 sugar. Gerarde says, that a very good bread was made from them in his time. They afford as much spirit as the carrot, and make an excellent wine.

5481. *To save parsnep seed*, proceed as with the carrot. The parsnep, being more hardy and luxuriant than the carrot, is less liable to the mildew and worms, but equally so to become forked if the soil be not deep and well pulverised, and the manure minutely divided and equally distributed.

SECT. V. *The Field Beet.* — *Bèta* L.; *Pentándria Digýnia* L., and *Chenopòdeæ* J. *Betterave Champêtre*, Fr.; *Mangold-würzel*, Ger.; *Biétola*, Ital.; and *Betarraga*, Span.

5482. *The field-beet*, commonly called the mangold-würzel, and sometimes erroneously the root of scarcity (in German *mangel würzel*), is supposed by Professor Thaer to be a mongrel between the red and white beet. It has a much larger bulb than either, and that bulb, in some varieties, grows in great part above ground. It has been a good deal cultivated in Germany and Switzerland, both for its leaves and roots; the leaves are either used as spinach or given to cattle; and the roots are either given to cattle, used in distillation, or in the manufacture of sugar. The culture of the field-beet in Britain is very recent, and it may be questioned whether it has any advantages over the turnip for general agricultural purposes. It admits, however, of being cultivated on ridgelets and with as little manual labour as the turnip, while it will prosper on a stronger soil, and near large towns it is not liable to the depredations usually committed on turnips or carrots, as the root is unpalatable either raw or boiled.

5483. *The variety* preferred in Germany is one slightly tinged with red for cattle, and the pale yellow variety for the distillery and sugar manufacture. The seed must not exceed a year old, and great care should be taken that the seed of the common red and white beet are not mixed with it. The seed of every variety of beet is very apt to degererate.

5484. *Any soil* will suit this plant provided it is rich: immense crops have been raised on strong clays; but such soils are not easily prepared for this sort of crop, and are also ill adapted for after-culture.

5485. *The preparation* should be exactly the same as for turnips; and the seed should be sown on the ridgelets in the same manner. Some, however, dibble in the seed in order to save the expense of thinning. The season of sowing is the same as for the parsnep, and should not be deferred later than the middle of April. The after culture consists in horse-hoeing, hand-hoeing, and weeding, as in the culture of the turnip, and the plants are thinned out to about the same distance in the rows. Blanks may be filled up by transplanting, or, as in the case of the Swedish turnip, whole crops may be reared in this way; but the produce is never so large. As the transplanting, however, takes place in May, more time is afforded, and drier weather obtained for cleaning the soil. The plants are set by the dibbler along the centre of the ridgelets, which are previously consolidated by rolling.

5486. *The produce* is, *cæteris paribus*, about the same as that of the Swedish turnip; but the nutritive matter afforded by the beet is 136 parts in 1000, of which 13 are mucilage, 119 sugar, and 4 gluten. According to Von Thaer, they afford ten per cent. of nutritive matter, and are in that respect to hay as 10 to 46, and to potatoes as 20 to 46. An acre would thus appear to afford more nourishment than turnips, carrots, or parsneps.

5487. *Practical men* are not agreed as to the value of this root, compared with the Swedish turnip; but the majority seem to think, that as a food for milk cows, the mangold is to be preferred, more especially as it gives no unpleasant taste to the milk and butter. It has this advantage over turnips, that it thrives better than they do in a dry warm season, being a plant that naturally requires more light and heat than the turnip.

5488. *The application of the field-beet* is almost confined to the fattening of stock, and feeding of milch cows. Near London they are in repute for the latter purpose; and, according to Von Thaer, they cause a great increase of milk, as well as improve its flavour. The tops are first taken off, and given by themselves; and then the roots are taken up, washed, and given raw. The roots are much more easily injured by frost than the turnip, carrot, or parsnep, and are stored with difficulty. The leaves make a very good spinach, but the roots cannot be used in cooking like those of the red beet. In the distillery it is nearly half as productive as the potato; but, according to Von Thaer, it is not likely to yield much profit in the manufacture of sugar.

5489. *The manufacture of sugar from mangold würzel* is still, however, carried on in France, and, although we think it can never ultimately compete with that from the cane, it seems of late years to be on the increase. We shall therefore give a short account of the process, premising that the greatest quantity of sugar is not obtained from the greatest bulk of root, but rather from small roots produced from dry calcareous soils, at the rate of from fifteen to twenty-five tons an acre. One cwt. of sugar is the general produce obtained by the most perfect apparatus from one ton of root. As soon as the leaves begin to turn yellow, the root may be said to have arrived at maturity; and it is time to take up the crop, and to begin the process of sugar-making, an operation which continues from October to February in the larger manufactories. Take the roots up dry, and keep them so; the smaller the heap the better, because the least fermentation will effectually prevent the formation of sugar. The difference in amount and quality of sugar is always in favour of that made at the beginning of the season. The root, in keeping, undergoes a chemical change, often amounting to a total loss of its saccharine matter; although its outward appearance indicates no such change.

5490. *Process of sugar-making.* The roots should first be washed, and then rasped, to reduce them to a state of pulp. Of course, in large manufactories, they are provided with rasping machines; and it is

somewhat difficult to find a substitute on a small scale. I should imagine, though, that a stout iron plate, punched with triangular holes, the rough edges of which are left standing, somewhat after the manner of a nutmeg-grater, might answer the purpose, only that I would have it somewhat concave instead of convex. Upon the rough side of this plate I would rub the roots by hand. If there should be a cider-mill and press within a reasonable distance, it might answer to take the roots thither, slice them, and pass them through the mill. When by these or any other means they are reduced to pulp, the juice should be pressed from the pulp, which is thus done:—It is put into canvass bags, not too fine, so as to impede the running of the juice, nor yet so coarse as to let the pulp through the meshes. The bags should be so fitted as, when pressed, to occupy about an inch in depth. Most manufactories use about twenty-five of these bags at one pressing, but this depends on the power of the press. Between every bag of pulp is laid a sort of osier hurdle, to allow the juice to percolate freely from the press into the juice-cistern below. The operation of pressing should immediately follow that of rasping. This point should be particularly attended to.

5491. *Defecation.* The juice being expressed from the pulp, the next process is the defecation of the juice, and here, too, no time should be lost. This is effected by boiling: a copper boiler should be used. Get up the fire till the thermometer indicates 170° or 178°. Then add sifted lime (quick) previously mixed with water, at the rate of five or six pounds for every 100 gallons of juice. Stir it well up, and skim the liquor. Heat it till the thermometer reaches 200°. Add sulphuric acid in small portions, diluted with six times its bulk of water, to neutralise the effect of the lime, stirring it briskly each time. The proper quantity is ascertained by carefully examining the juice every time the acid is added, with a drop of syrup of violets in a spoon, which ought to turn of a green colour. About thirty ounces of the acid to every 100 gallons of juice will be necessary. This done, the fire is quenched, and the boiler left to settle for half an hour; at the end of which time, the liquor is drawn off: by some, bullock's blood is added when the temperature of the juice reaches 190° in the proportion of two pints and a half to every twenty gallons of juice. Some, too, apply the sulphuric acid to the juice when cold, instead of hot, viz. before the boiler-fire is lighted; and one recommends its being applied to the pulp before it goes into the boiler: but all this practice will decide.

5492. *Concentration.* The next process is concentration of the juice, which means nothing more than evaporating from it the water therein contained. This is effected by flat pans, over a brisk fire, but not so as to burn the syrup, which is the great danger in this operation. When reduced in pan 1 from 4 to 2 inches or so in depth, it is put into a smaller pan (2), and reduced to the same depth, and afterwards into a third pan. These three removals are the work of an hour and a half. If the syrup rises, and threatens to overflow the pan, put in a small lump of butter, which will make it subside.

5493. *Clarification.* This the next operation, and may be carried on in one of the pans used for concentration. Animal charcoal (some have even used wood charcoal) is now applied, at the rate of half a pound for every gallon of syrup, which renders it perfectly black and muddy. In this state, add blood mixed with water (stirred up well with the syrup), in the proportion of about a pint and a half of blood to every twenty gallons of syrup.

5494. *Boil it a short time*, after which it is filtered, and then boiled again, care being taken not to burn the pan. Great care is necessary in examining the state of the syrup from time to time. The thermometer ought to stand as high as 234°; on attaining which, the pan should be emptied: eighteen gallons of syrup will be reduced, by boiling, to eleven gallons. The syrup is next cooled in a suitable vessel to 182° or 190°, and then run into moulds; but the cooling is very gradual. The pan is covered, and the heat kept in by closing the edges with flannel. The syrup is then poured into large earthen moulds cone-shaped, and with a hole at bottom, through which the molasses drains. This hole is temporarily stopped till the mould is full. A mould contains ten or twelve gallons, and requires a month to purge itself. As it cools, it crystalises. The syrup, whilst filling, is at 67° to 77°; but, in the course of purging, it is raised to 120° and even 145°, which expedites the flow of the molasses. Our next process is *turning the moulds*, i. e. setting the cones on their bases, and taking them out of the moulds. The point of the cone is moist and syrupy: this is cut off, and boiled over again with the molasses. Thus far the process of making brown sugar: refining is a different business, and one which there is no occasion to particularise here. It is to be observed, that copper utensils are preferred to those of iron, the latter having a chemical effect on the sugar. (*Gard. Mag.* vol. vi. pp. 150, 151.)

5495. *To save seed*, select the finest specimens, preserve them in sand during winter, and plant them in an airy part of the garden in March. The rest is easy.

5496. *To diseases* no plant is less liable than the beet.

SECT. VI. *The Cabbage Tribe.*—*Brássica* L.; *Tetradynàmia Siliquòsa* L., and *Cruciferae* J. *Chou*, Fr.; *Kohl*, Ger.; *Cavolo*, Ital.; and *Col*, Span.

5497. *The cabbage tribe* is of the greatest antiquity in gardens, and most of the species may be cultivated in the fields with success. For the common purposes of farming, however, there can be little doubt that they will afford less profit than any of the plants hitherto treated of in this chapter; but near large towns or sea-ports they may answer the purpose of the farm-gardener. Cabbage culture, Brown observes, is much more hazardous, far less profitable, and attended with infinitely more trouble, than that of turnips; while the advantages to be derived are not, in our opinion, of a description to compensate the extra hazard and trouble thereby incurred.

5498. *The culture of cabbage* has been strongly recommended by several speculative agriculturists, and examples adduced of extraordinary produce and profits; but any plant treated in an extraordinary manner will give extraordinary results; and thus an inferior production may be made to appear more valuable than it really is. One reason why so much has been said in their favour, by Arthur Young and other southern farmers, is, that they compare them with the produce of turnips, which, in the south of England, is averaged at only fifteen tons per acre.

5499. *The variety of cabbage*, cultivated in the fields for cattle, is almost exclusively the large field cabbage, called also the Scotch, Strasburg, drumhead, &c. For the purposes of domestic economy, other varieties of early and late cabbage, as the York, Battersea, sugar-loaf, imperial, &c. are grown; and also German greens, Savoy cabbage, and even Brussels sprouts and broccoli.

5500. *The cow cabbage, Cesarean cole, or tree cabbage* (*Brássica oleràcea* L. var. *acéphala* Dec.; *Chou cavalier*, *Chou à vachcs*, *Chou branchu*, *Chou en arbre*, *Chou mille têtes*, Fr.; *Caulet*, Flem.), is much cul-

tivated for milch cows in French Flanders, the Netherlands, and in Jersey and Guernsey; and it has been introduced, at different periods, into this country, without having ever come into general cultivation. The *Chou caulet de Flandre* differs from the French variety in having red leaves; and the *Chou vert branchu*, the *Chou mille têtes du Poiteau*, differs from the first in not growing quite so high, and in forming a somewhat tufted head. No variety among these, and the many that might be named, appear so suitable for field culture in the climate of Britain as the Scotch or drumhead cabbage.

5501. In Jersey the cow cabbage is sown from about the 20th of August to the 1st of September, in a good soil, and planted out from November to January and February in succession, at from twenty to thirty inches' distance, in a good, substantial, well manured soil; as no plant is more exhausting, or requires a better soil; but perhaps no one plant produces so large a quantity of nutriment during its period of vegetation. About the month of April they begin (from the first crop) to strip the under leaves; cut them in small pieces; mix them with sour milk and bran, or other farinaceous substances; and give them as food to ducks, geese, hogs, &c. During the whole summer they continue stripping the plant as above stated, until it attains the height of from six to twelve feet; and if a scarcity of herbage prevails, the green leaves form excellent food for cows and oxen, with alternate feeds of hay and straw. The tops and side shoots are excellent at table during winter and spring. The longest of the stalks are frequently used to support scarlet runners and other French beans, and as cross rafters for farm buildings, under thatch, and have been known to last more than half a century, when kept dry, for the latter purpose. (*Gard. Mag.* vol. v.)

5502. Any soil that is rich will suit the cabbage, but a strong loam is preferred. The best mode of preparation for field cabbage is that for potatoes or turnips, the plants being dibbled along the centre of each ridgelet. For early cabbage no ridgelets are required, as the plants are inserted in rows, by a line, at much narrower distances.

5503. The season for planting, for a full crop of field cabbages, is usually March; but cabbages may be planted as late as June, and produce a tolerable crop by November; and in this way they may sometimes be made to succeed an unsuccessful sowing of turnips. The plants used in March should be the produce of seed sown, in an open loamy part of the garden, in the preceding August; but those planted in May or June may be the produce of seed sown in the February or March of the same year.

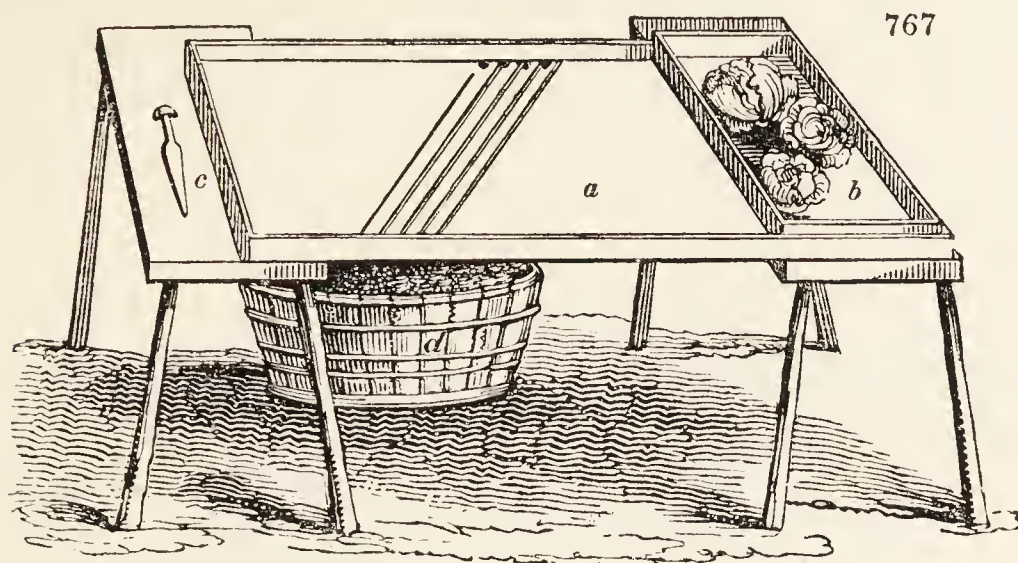
5504. The preparation given to the plants consists in pinching off the extremity of their tap-root, and any tubercles which appear on the root or stem, and in immersing the root and stem in a puddle, or mixture of earth and water, to protect the fibres and pores of the root and stem from the drought. The plants may then be inserted by the dibber, taking care not to plant them too deep, and to press the earth firmly to the lower extremity of the root. If this last point is not attended to in planting by the dibber, the plants will either die, or, if kept alive by the moisture of the soil or rain, their progress will be very slow. When the distance between the ridgelets is twenty-seven inches, the plants are set about two feet asunder in the rows; and the quantity required for an acre is about 6000 plants. Some recommend sowing as for turnips; but, by this mode, one of the advantages of a green crop is infringed on, viz. the time given to clean the land. Where cabbages are sown, that operation must be performed at least a month sooner than if they were planted; consequently, the best month of the cleaning season is lost. To plant or sow a green crop on land in good heart, that does not require cleaning, will seldom be found good husbandry. It may succeed near large towns, where roots and other green produce sell high, but it can never enter into any general system of farming.

5505. The after-culture consists in horse and hand-hoeing and weeding; and the crop is taken by chopping off the heads with a spade, leaving an inch or two of stalk to each. They may be preserved by housing, but only for a short time. The produce is said to be from thirty-five to forty tons per acre. Sir H. Davy found that 1000 parts of cabbage gave seventy-three of nutritive matter, of which forty-one are mucilage, twenty-four saccharine matter, and eight gluten.

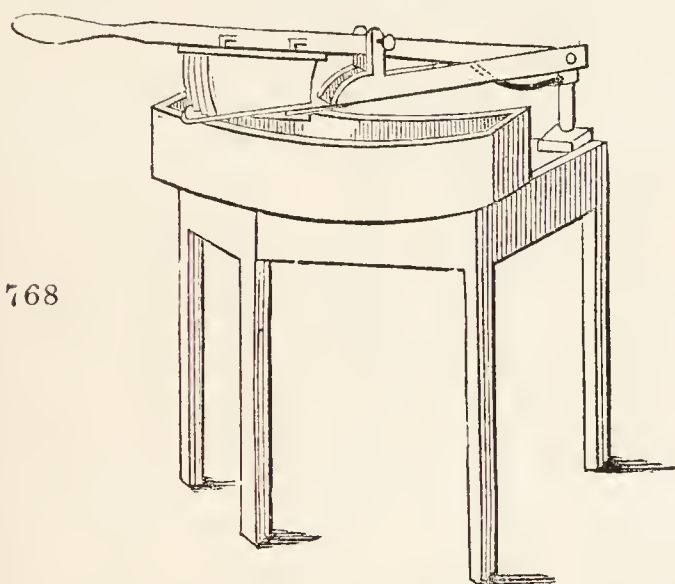
5506. The application of the field cabbage is generally to the feeding of milch cows, and sometimes to the fattening of oxen and sheep. For the former purpose, great care must be taken to remove the outside decaying leaves; otherwise they are apt to give an unpleasant flavour to the milk and butter. Cabbages are also eaten by swine and horses, and are reckoned excellent food for sheep that have newly dropped their lambs, and for calves. A cow will eat from 100 to 150lbs. of cabbage per day, and a sheep ten or twelve pounds, besides a moderate allowance of hay. Some farmers consider that ewes fatten faster on cabbages than on turnips, and that ewes having lambs are much more prolific in milk when so fed. (*Country Times*, Feb. 8. p. 47.) Early or garden cabbages are sold to green-grocers, or to the consumers, or to ships' victuallers for the purpose of being pickled or made into sour crout.

5507. Salted cabbage, or sauerkraut, is thus prepared in Germany:— Any sort of cabbage or kail, or even turnips and kidneybeans, may be prepared in this way; but white, compact-headed, large cabbages are preferred, and next compact-headed red cabbages. The first process of preparing them is to scoop out the interior part of the stalk, with an iron instrument or scoop; they are then cut into small shreds by a wooden machine, composed of a flat board or tray, which has a ledge on two sides, to steady a box or frame into which the cabbages are put. In the middle of the board are four flat pieces of steel, similar to the steel part of a spokeshave, placed in an oblique direction; and the near edge of each being a little raised up, with small spaces between each, to let the shreds fall down into a tub placed underneath to receive them. The cabbages are then put into the box before described, which is pushed backwards and forwards, when the cabbages, being cut by the steel, fall in small shreds into a tub placed below. A barrel stands by ready to receive them when cut, the sides of which are first washed with vinegar. A man stands on a chair by the barrel, with clean wooden shoes on, whose business it is to salt and prepare them, which is done in the following manner: the man first takes as much of the cut cabbage as covers about four inches above the bottom; he next strews upon it two handfuls of salt, one handful of unground pepper, and a small quantity of salad oil; he then gets into the barrel, and treads it down with his wooden shoes till it is well mixed and compact. He next takes another layer of cabbage, and puts salt and pepper on it as before, and treads it again, and so goes on till the barrel is filled. A board is then placed on it, and upon the board some very heavy weights are put; and it remains so ten or fifteen days, when it partially ferments, and a great deal of water swims on the surface: it is then put into the cellar for use. The men

who prepare sauerkraut are Tyrolese, and carry their machine (*fig. 767.*), which has not been invented more than ten or twelve years, on their backs from house to house. This machine contains a cutting tray (*a*), box into which the cabbages are placed (*b*), scoop (*c*), and tub into which the shreds fall (*d*). (*Gard. Mag.* vol. iii. p. 343.)



5508. *Newton's machine for chopping cabbage* or other vegetables, roots, or meat (*fig. 768.*), consists of



of five knives let into an iron plate, and the latter is screwed to the working bar. The knives are fastened, by bolts passing through them, close under and above the iron plate. The sliding plate is for the purpose of preventing the meat from being scattered; and to this plate are added scrapers, which are serewed underneath, for the purpose of cleaning the knives at every stroke. A spring raises the knives, and enables any person to chop at least twenty times as much meat, in the same time, as can be done by the common mode. The length of the knives being equal to the breadth of the trough, no meat can possibly escape the knives; nor will the meat require so much turning as is usually wanted. When it does require turning, it is easily done by alternately pressing the knives at either end of the trough, sliding them towards the middle. The machine is also applicable for cutting fat, suet, &c. previously to rendering them into tallow; likewise to chopping madder and other roots for calico printers, or as used in their recent state for dyers; and for dividing potatoes, carrots, and other esculent roots, cabbage for sauer kraut, and

roots used in feeding cattle. (*Smith's Mechanic*, vol. ii. p. 360.)

5509. *To save cabbage seed*, select a few fine specimens, and plant them by themselves where they will be in no danger of being contaminated by others of the *Brássica* tribe when in flower. The seed will keep many years.

5510. *The diseases of cabbages* are the same as those of the turnip, with the exception of the forked excrescence. On the roots of the plants are frequently found knobs, which, in the preparation for transplanting, should, as we have already observed, be carefully removed.

SECT. VII. *Other Plants which might be cultivated in the Fields for their Roots or Leaves, as Food for Man or Cattle, in a recent State.*

5511. *Every hardy garden plant* may be cultivated in the fields, and with very little manual labour. Accordingly we find onions, spinach, cress, radishes, and even cucumbers, grown by farmers, or farm gardeners in the neighbourhood of the metropolis, and also in other places. None of these plants, however, can be considered as belonging to agriculture; nor should we notice those which follow, but because they have been tried and recommended by zealous cultivators, and are treated of in some works on farming. No plant can be considered as belonging to agriculture that is not in sufficient demand, or of sufficient general use in feeding stock, as to admit of its frequent occurrence in rotations; and such certainly cannot be said to be the case with the Jerusalem artichoke and lettuce, now about to be noticed.

5512. *The Jerusalem artichoke* (*Helianthus tuberosus L.*; *Topinambour*, Fr.) is a tuberous-rooted plant, with leafy stems from four to six feet high. It thrives well on soft moist soils, and even, it is said, on moist peat soils; and it is alleged that its tops will afford as much fodder per acre as a crop of oats, or more, and its roots half as many tubers as an ordinary crop of potatoes. (*Agricultural Magazine*, 1807-8.) The soil may be cultivated in all respects like the potato. The tubers, being abundant in the market gardens, are to be had at little more than the price of potatoes. The fibres of the stems may be separated by maceration, and manufactured into cordage or cloth; and this is said to be done in some parts of the north and west of France, as about Hagenau, where this plant, on the poor sandy soils, is an object of field culture.

5513. *The common Cos lettuce* (*Lactuca sativa L.*) has been grown for feeding pigs, and other purposes. Arthur Young informs us, in his *Calendar of Husbandry*, that he first observed the sowing of lettuces for hogs practised, on a pretty regular system, on the farm of a very intelligent cultivator (not at all a whimsical man) in Sussex. He had every year an acre or two, which afforded a great quantity of very valuable food for his sows and pigs. He adds, that it yields milk amply, and all sorts of swine are very fond of it; and he thinks that the economical farmer who keeps many hogs should take care to have a succession of crops for these animals, that his carts may not be for ever on the road for purchased grains, or his granary opened for corn oftener than is necessary. To raise this sort of crop, the land should have been ploughed before the winter frosts, turning in by that earth twenty loads of rich dung per acre, and making the ridges of the right breadth to suit the drill-machine and horse-hoes, so that in the month of March nothing more may be necessary than to scarify the land, and to drill the seed at one foot equidistant, at the rate of four pounds of seed per acre. Where the stock of swine is large, it is proper to drill half an acre or an acre of lettuce in April, the land having been well manured and ploughed as directed above, being also scuffled in February and March, and well harrowed, repeating it before drilling: and at this period, the crop which was drilled in March (a succession being essentially necessary) should be thinned in the rows by hand, to about nine or ten inches asunder. If this necessary attention be neglected, the plants, he says, draw themselves up weak and poor, and will not recover it. Women do this business as well as men. When about six inches high, they should be horse-hoed with a scarifier or scuffler, having the hoe about four inches, or at most five inches in width. With this sort of green food, some kind of meal or other dry meat should be combined, as without it it is apt to prove very laxative, &c. This Sussex cultivator is not likely to be followed by any rent-paying farmer who can grow any of the clovers, turnips, or potatoes. The quotation affords a good specimen of Arthur Young's mode of writing on agricultural subjects.

5514. *The chicory, wild endive, or succory* (*Cichorium Intybus L.*; *Chicorée sauvage*, Fr. fig. 769.) has long, thick, perpendicular roots, a tuft of endive or lettuce-looking leaves; and, when it shoots into flower, its stems rise from one to three feet high, rigid, rough, branched, and clothed with leaves and blue flowers. It is found wild in dry calcareous soils in England, and in most parts of Europe of similar or greater temperature. It is cultivated in France as an herbage and pasturage plant, and in Germany and Flanders for its roots, from which a substitute for coffee is prepared. It was first cultivated in this country, about 1780, by Arthur Young, who holds it in very high estimation. It is of such consequence, he says, for different purposes of the farm, that on various sorts of soil the farmer cannot, without its use, make the greatest possible profit. Where it is intended to lay a field to grass for three, four, or six years, in order to rest the land, or to increase the quantity of sheep food, there cannot, he thinks, be any hesitation in using it. There is no plant to rival it. Lucern, he says, demands a rich soil, and will always be kept as long as it is productive; but upon inferior land it is not an equal object. Upon blowing sands, or upon any soil that is weak and poor, and wants rest, there is no plant, he supposes, that equals this. On such sort of blowing poor sandy lands as many districts abound with, especially in Norfolk and Suffolk, it will yield a greater quantity of sheep food than any other plant at present in cultivation. On fen and bog lands, and peat soils, it also thrives to much profit. On all land where clover, from having been too often repeated, is apt to fail, chicory may be substituted to great advantage. It does very well for soiling cattle, both lean and fattening. It is of excellent use for those who keep a large stock of swine; and it does exceedingly well in an alternate system of grass and tillage, as it will last four, five, six, and even more years; but it should

not be sown with any view of making hay in this climate, though it forms a considerable proportion of many of the best meadows in the south of France, and in Lombardy. It has, however, he adds, been objected to, on the ground of its rising and becoming a vivacious weed in succeeding crops: and if this circumstance be not guarded against, it will, he says, happen; but not more than with lucern, nor so much. But who, he asks, ventures to forbid chicory culture on account of this quality, which is really founded on its merit? When the land is ploughed, says he, only use a broad sharp share, and harrow in tares for feeding or soiling, or break it up for turnips, and there is an end of the objection.

5515. *The culture of chicory is the same as of clover.* As the plant is grown in gardens for culinary purposes, the seed may be procured in the seed-shops, gathered in many places from wild plants, or saved by the grower. It is small, flat, black, and resembling that of lettuce; it should be procured fresh; and from eight to twelve pounds an acre are usually sown. The culture of this plant for its roots has been noticed in giving the outline of the agriculture of Flanders, and will be adverted to in a succeeding Chapter.

5516. *The rough comfrey*, (*Symphytum asperrimum L.* fig. 770.), a perennial from Siberia, has been

brought into notice by D. Grant, a nurseryman at Lewisham, and tried by a number of cultivators. Cattle of every kind are said to be fond of this plant; and so great is its produce on good soil, that Mr. Grant thinks an acre might be made to produce thirty tons of green fodder in one year. He has grown it to the height of seven feet as thick as it could stand on the ground. The plant is of easy propagation by seed or division of the roots; the better way would probably be to sow in a garden, and transplant when the plants were a year old. All the symphytums are plants of

great durability, so that this species, if once established, would probably continue to produce crops for many years; and, in that point of view, it would seem to be a valuable plant for the cottager who keeps a cow. (*Gard. Mag.* vol. v. and *Country Times*, May 10th, 1830.)

5517. *The day lily* (*Hemerocallis fulva L.*, fig. 771.) was brought into notice by Mr. Elles, late of Longleat. In the years 1826-7, he observed, accidentally, how extremely fond cattle were of this plant, even eating it down to the roots when an opportunity occurred; and as he knew, from long experience, that it would, even in dry ground, produce herbage in the middle and latter end of



April, equal in quantity to any water meadow, the extreme facility with which it may be propagated and grown in almost any soil and situation, and also its apparently nutritious nature, he was induced to give it a trial in a plot of ground of about twenty rods, attached to the cottage in which he lived. He did so, and after two years' trial found the day lily produce a supply of green food in April and towards the middle of May, when there is little or no pasture grass, and never could detect any unpleasant flavour in the milk or butter, though given in considerable quantities. The day lily, of which there are two species, differing very little in appearance, *H. flava* and *fúlva*, is a perennial of great duration, rapid increase, and of easy propagation by division. It certainly well deserves trial as a permanent herbage plant, especially for the cottager and small farmer. (*Gard. Mag.* vol. v. p. 441.)

CHAP. V.

Culture of Herbage Plants.

5518. *The cultivation of clovers and other herbage plants*, used exclusively as food for live stock, is comparatively a modern improvement. They were known, as we have seen, to the Greeks and Romans, and cultivated from a very early period in the low countries; but do not appear to have attracted much notice in Britain till the sixteenth century, when our frequent intercourse with Holland led to the introduction of some of our best field plants and agricultural practices. At present clovers enter largely into the succession of crops, on all soils, and in every productive course of management. Before they were introduced into cultivation, it was necessary, when land was exhausted by grain crops, to leave it in a state of comparative sterility for several years, before it became either valuable as pasture or again fit for carrying corn: but at present clovers are not only indispensable in the cultivation of white and green crops alternately, upon very rich soils, but are the foundation of convertible husbandry on land that is not so rich as to permit of a constant aration, and which therefore requires two or more years' pasturage at certain intervals. Lucern and saintfoin, though of much less value as general crops, are valuable plants in particular situations; more especially the latter, which will produce good crops on dry chalky and limestone soils, where most other agricultural plants, and even grasses, would barely maintain their existence.

5519. *The characteristic points of culture* of this class of plants are broad-cast sowing, mowing, soiling, and hay-making; and that when cut for the two last purposes, two or more crops may be had in a season from the same roots.

5520. *The nutritive products* of the principal herbage plants are thus given by Sir H. Davy: —

Systematic Name.	English Name.	In 1000 Parts.				
		Whole quantity of soluble or nutritive matter.	Mucilage, or starch.	Saccharine matter, or sugar.	Gluten, or albumen.	Extract, or matter rendered insoluble during evaporation.
<i>Trifolium pratense</i> -	Red clover -	39	31	3	2	3
<i>medium</i> -	Cow clover -	39	30	4	3	2
<i>repens</i> -	White clover -	32	29	1	3	5
<i>Hedysarum Onobrychis</i> -	Saintfoin -	39	28	2	3	6
<i>Medicago sativa</i> -	Lucern -	23	18	1	—	4

SECT. I. *The Clover Family.* — *Trifolium* L.; *Diadélphia Decándria* L., and *Leguminosæ* J. *Tréfle*, Fr.; *Klee*, Ger.; *Trifoglio*, Ital.; and *Trebol*, Span.

5521. *The clovers* (*fig. 772.*) are a numerous family, chiefly natives of Europe: those selected by the agriculturist are natives of Britain; and one species, the white or creeping clover, is often found in great luxuriance in native pastures. As rye-grass is very generally sown with clovers, it will be necessary to treat of its culture in connection with these plants, reserving, however, the more particular consideration of rye-grass till we treat of the hay grasses. (Chap. VI.) Many intelligent cultivators consider rye-grass as a very severe crop for the soil; and it is alleged that wheat does not succeed well after the herbage with which rye-grass is intermixed in any considerable quantity. Other plants have accordingly been recommended as a substitute for rye-grass, and cock's-foot (*Dáctylis glomerata*) has been tried, apparently with great success, by Coke of Holkham in Norfolk, and others; but this is a very coarse grass when allowed to rise to any height, and the use of it for hay has not yet been ascertained. Donaldson considers the general introduction of clovers, and the cultivated grasses, as one of the greatest improvements in modern husbandry. The commencement of improvements in the different species of live-stock, in the modes of cultivation, and in the superior quality, as well as quantity, of the crops of grain, may all, he thinks, be dated from the period when the sowing of clovers and grass-seeds was first introduced into the different districts of the kingdom.

5522. *The species of clover in cultivation are: —*

5523. *The red clover* (*Trifolium pratense*, fig. 772. *a*), a biennial, and sometimes, especially on chalky soils, a triennial plant, known from the other species by its broad leaves, luxuriant growth, and reddish purple flowers. In its wild state a perennial.



5524. *The white, or creeping, or Dutch clover* (*T. repens*, *b*), a perennial plant, known by its creeping stems and white flowers.

5525. *The yellow clover, hop-trefoil, or shamrock clover, the black nonsuch of the Norfolk farmers* (*T. procumbens*, *c*), an annual, known by its procumbent shoots and yellow flowers. This species is seldom cultivated; the yellow clover of the seed shops being the *Medicago lupulina*, the lupuline, or minette dorée of the French. (fig. 773.)



5526. *The meadow clover, cow-clover, cow-grass, or marl-grass, the first the best name* (*T. medium*, *d*), a perennial, resembling the red clover, but of a paler hue, dwarfer habit, with pale red or whitish flowers, and long roots very sweet to the taste. This species is but partially cultivated, and it is extremely difficult to procure the seeds genuine. It comes into flower from twelve to fifteen days later than the common red clover, has a solid stalk, a narrower leaf, and both leaves and flowers have a paler hue. A poor sandy soil, it is said, will produce a good crop of cow-clover that would not produce half a crop of the common red clover; it is also as good the second year as the first. Some farmers sow it because the crop comes in between the first and second cutting of the red clover as green food.

5527. *The flesh-coloured clover* (*Trifolium incarnatum* Lin.; *Farouche* or *Trefle de Roussillon*, Fr. fig. 774.) has long been cultivated in some of the southern departments of France, and, though an annual, is found very advantageous on dry sandy soils. The Agricultural Society of Nancy have lately recommended it for culture in the province of Lorraine; and a writer in the *Journal des Pays-Bas*, as suitable to many parts of the Netherlands. M. de Dombasle, a theoretical and practical agriculturist in great estimation, sows it, after harvest, in the stubbles, with no other culture than harrowing in. It grows all the winter, and early in spring affords abundant food for sheep; or, if left till May, it presents a heavy crop for the scythe, and may be used for soiling, or making into hay. (*Gard. Mag.* vol. iv. p. 392. and vol. v. p. 734.) It was introduced into England about the year 1824, by Mr. John Ellman, jun. of Southover, near Lewis, who gives directions for sowing it in March without a corn crop, and states that it will be in full bloom and fit to cut by June. He says it is very productive; but should not be sown with corns like other clovers, because it grows so fast as to choke them. (*Farm. Jour.* March 17. 1828.)



5528. *Trifolium Molinieri filiforme* (with yellow flowers), *campêtre* (also with yellow flowers), and *fragiferum*, are cultivated in France; but we believe chiefly on the poorer soils. Seeds of them and of all the other species may be correctly

obtained from Vilmorin-Andrieux and Co., seed merchants in Paris.

5529. *In the choice of sorts* the red or broad clover is the kind most generally cultivated on land that carries corn and herbage crops alternately, as it yields the largest produce for one crop of all the sorts. White and yellow clover are seldom sown with it, unless when several years' pasturage is intended.

5530. *The soil best adapted for clover* is a deep sandy loam, which is favourable to its long tap-roots: but it will grow in any soil, provided it be dry. So congenial is calcareous matters to clovers, that the mere strewing of lime on some soils will call into action clover-seeds, which it would appear have lain dormant for ages. At least this appears the most obvious way of accounting for the well known appearance of white clover in such cases.

5531. *The climate most suitable for the clovers* is one neither very hot nor very dry and cold. Most leguminous plants delight both in a dry soil and climate, and warm

temperature, and the clover will be found to produce most seed under such circumstances; but as the production of seed is only in some situations an object of the farmer's attention, a season rather moist, provided it be warm, is always attended by the most bulky crops of clover herbage.

5532. *The preparation of the soil and the manures*, which clover receives in ordinary farm culture, are those destined also for another crop; clover mixed with a certain proportion of rye-grass being generally sown along with or among corn crops, and especially with spring-sown wheat, barley, and the early varieties of oats. Unless, however, the soils on which these crops are sown are well pulverised, and have been some years under tillage, clovers will not succeed in them, it being ascertained that newly broken-up leys or pasture grounds cannot be sown down or restored to clover and grasses till the soil is thoroughly comminuted, and the roots of the former grasses and herbage plants completely destroyed.

5533. *The time of sowing* clover-seeds is generally the spring, during the corn seed time, or from February to May; but they may also be sown from August to October, and when they are sown by themselves, that is, unaccompanied by any corn crop, this will be found the best season, as the young plants are less liable to be dried up and impeded in their progress by the sun, than when sown alone in spring and remaining tender and unshaded during the hot and dry weather of July.

5534. *Some prepare the seed* for sowing by steeping in water or in oil as in Switzerland, and then mixing it with powdered gypsum, as a preventive from the attacks of insects.

5535. *The manner of sowing* is almost always broad-cast. When sown with spring corn, clover and grass-seeds are usually put in immediately after the land has been pulverised by harrowing in the corn-seed, and are themselves covered by one course more of the harrows; or, if the corn is drilled, the small seeds are sown immediately before or after hand-hoeing; and the land is then finished by a course of the harrows. Clover is generally sown by hand, though of late years the broad-cast drill (*fig. 722.*) has been used, both in the case of the clovers and the grasses. A lighter harrow is generally employed in covering such seeds, than that used for corn. When the land is under an autumn-sown crop of wheat or other grain, though the clovers and rye-grass are still sown in spring, the proper period must depend both upon the state of the land and the progress of the crops; and it may be often advisable to break the crust formed on the surface of tenacious soils, by using the harrow before the clovers are sown, as well as afterwards to cover them. Sometimes the roller only is employed at this time, and there are instances of clover and rye-grass succeeding when sown, without either harrowing or rolling. But it is commonly of advantage to the wheat crop itself, to use the harrows in spring, and the roller alone cannot be depended on, unless the season be very favourable. In some cases grass-seeds are sown by themselves, either in autumn or spring, but rarely on tillage land. Nature has not determined any precise depth for the seed of red clover more than other seed. It will grow vigorously from two inches deep, and it will grow when barely covered. Half an inch may be reckoned the most advantageous position in clay soil; a whole inch in what is light or loose. It is a vulgar error, that small seed ought to be sparingly covered. Misled by that error, farmers commonly cover their clover seed with a bushy branch of thorn; which not only covers it unequally, but leaves part on the surface to wither in the air.

5536. *In the operation of sowing* some consider it best to sow the clover and rye-grass separately, alleging that the weight of the one seed, and lightness of the other, are unfavourable to an equal distribution of both.

5537. *The quantity of seed* sown on an acre is exceedingly various; not only when more or less white or yellow clover is sown along with grass-seeds and red clover, or when pasturage is intended; but, even when they are the only kinds sown, the quantity is varied by the quality of the soils, and the different purposes of hay, soiling, or one year's pasture, to which the crop is to be applied. When pasture is the object, more seed ought to be allowed than is necessary when the crop is to be cut green for soiling; and for hay, less may suffice than for either of the former. Finely pulverised soils do not require so much seed as clays, on which clover and rye-grass are very frequently sown among autumn or winter-sown wheat, when there is more danger of a part of it perishing from being imperfectly covered. In general, eight or ten pounds may be taken as the *minimum* quantity, though there have been instances of good crops from less; and from that to fourteen pounds or more per English statute acre. Rye-grass, commonly at the rate of a bushel per acre, but in many cases only half, or two thirds of a bushel, is mixed with this weight of clover, and both are sown at the same time. The rye-grass may be either of the perennial or annual variety, as it is understood that the herbage is to be continued for only one year; and the annual is sometimes sown in preference, as producing a bulkier crop than the perennial.

5538. *When it is intended to retain the land in pasture for several years*, the quantity of red clover is diminished, and several kinds of more permanent herbage are added, the most common of which are white and yellow clover, and ribwort. No general rule can be laid down as to the proper quantity of each of these kinds; in some cases red and white clover are sown in equal proportions, and in others the latter is made greatly to predominate. The yellow clover and ribwort are not often sown at the rate of more than two or three pounds per acre. It is scarcely necessary to add, that, in this case, the rye-grass should always be of the perennial sort.

5539. *In the selection of clover and rye-grass seeds* particular attention should be paid to their quality and cleanness; the purple colour of the clover seed denotes that it has been ripe and well saved; and the seeds of weeds may be detected in it by narrow inspection, if there are any; but various noxious weeds are frequently mixed up with the seeds of the rye-grass, which it is difficult either to discover or to separate from them. Between the seeds of the annual and perennial rye-grass the difference is hardly discernible; and therefore, unless it is of his own growth, the cultivator must depend in a great measure on the character of the person from whom he purchases it. Red clover from Holland or France has been found to die out in the season immediately after it has been cut or pastured; while the English seed produces plants which stand over the second, many of them the third, year (*General Report of Scotland*, vol. i. p. 537.); thus remaining in the latter case four summers in the ground from the time of sowing.

5540. *The after-culture* of clover and rye-grass consists chiefly of picking off any stones or other hard bodies which may appear on the surface in the spring succeeding that in which it was sown, and cutting out by the roots any thistles, docks, or other large grown weeds. After this the surface should be rolled once to smooth it for the scythe. This operation is best performed in the first dry weather of March. Some give a top-dressing of soot, gypsum, common lime, peat, or wood-ashes, at this time or earlier:

gypsum has been particularly recommended as a top-dressing for clovers, and the other herbage legumes; because as their ashes afford that substance in considerable quantities, it appears to be a necessary ingredient of their food. Dutch ashes (427.) have been strongly recommended as a top-dressing for red clover, and they also contain gypsum; but where the soil is in good heart, and contains calcareous matter, any description of top-dressing, though it may be of advantage when it does not interfere with the general economy of the farm, cannot be considered necessary. (*Supp. E. Brit. art. Agr.*)

5541. *The taking of the clover, or clover and rye-grass crop*, is either by cutting green for soiling, by making into hay, or by pasturing. It is observed in *The Code of Agriculture*, that it is a most important point to ascertain in what cases cutting, or feeding, is more beneficial. If fed, the land has the advantage of the dung and urine of the pasturing stock; but the dung being dropped in irregular quantities, and in the heat of summer, when it is devoured by insects, loses much of its utility. If the dung arising from the herbage, whether consumed in soiling, or as hay, were applied to the land, in one body, and at the proper season, the operation would be more effectual. The smother of a thick crop, continued for any time upon the ground, greatly tends to promote its fertility; and it has been pretty uniformly found, after repeated trials, upon soils of almost every description, that oats or any other crop taken after clover that has been cut, either for soiling or hay, is superior to the crop taken after clover pastured by sheep.

5542. *Soiling* is a term applied to the practice of cutting herbage crops green for feeding or fattening live stock. On all farms, under correct management, a part of this crop is cut green, for the working horses, often for milch cows, and, in some instances, both for growing and fattening cattle. There can be no doubt of the advantages of this practice, in regard to horses and cows; but for young and for fattening beasts, a sufficient number of experiments are not known to have been yet made with any great degree of accuracy. Young animals require exercise in the open air, and, probably, will not be found to thrive so well in houses or fold-yards, during summer, as on pastures; and though in every case there is a great saving of food, the long, woody, and comparatively naked stems of the plants, with leaves always more or less withered, are perhaps not so valuable in the production of beef on fattening stock as a much smaller weight of herbage taken in by pasturage. Milch cows, however, are so impatient of heat and insects, that this way of feeding them, at least for a part of the day, in warm weather, ought to be more generally adopted; and the convenience of having working horses always at hand, besides that they fill their stomachs speedily, is of not less importance than economy. (*See Communications to the Board of Agriculture*, vol. vii. *Brown's Treatise on Rural Affairs*, vol. ii. *General Report of Scotland*, vols. ii. and iii.)

5543. *In feeding cattle with green clover*, attention must be paid to prevent swelling, or hoving, which is very apt to take place when they are first put on this food, especially if it is wet with rain or dew; and cattle are exposed to this danger, whether they are sent to depasture the clover, or have it cut and brought home to them; though, if the plants are somewhat luxuriant, the danger is greater in the former case. After being accustomed to this rich food for a few days, during which it should be given rather sparingly, the danger is much diminished; but it is never safe to allow milch cows, in particular, to eat large quantities of wet clover.

5544. *The making herbage plants into hay* is a process somewhat different from that of making hay from natural grasses. All the herbage tribe ought to be mown before the seed is formed, and indeed before the plants have fully blossomed, that the full juice and nourishment of the herb may be retained in the hay. By the adoption of this system, the hay is cut in a better season, it can be more easily secured, and it is much more valuable. Nor is the strength of the plant lodged in the seed, which is often lost. The great advantage of converting under-ripe herbage and grass into hay is now beginning to be known. There is much more saccharine matter in it, and it is consequently greatly more nutritious. A crop of clover or saintfoin, when cut in the early part of the season, may be ten per cent. lighter than when it is fully ripe; but the loss is amply counterbalanced, by obtaining an earlier, a more valuable, and more nutritious article; while the next crop will be proportionably more heavy. The hay made from old herbage which has ripened its seed will carry on stock, but it is only hay from herbage cut when young, and soon after it has come into flower, that will fatten them. When the stems of clover become hard and sapless, by being allowed to bring their seeds towards maturity, they are of little more value as provender than an equal quantity of the finer sort of straw of corn.

5545. *The mode of making clover-hay*, and that of all herbage plants, as practised by the best farmers, is as follows:—The herbage is cut as close to the ground and in as uniform and perfect a manner as possible with a sharp scythe. The surface having been in the preceding spring freed from stones and well rolled, the stubble after the mower ought to be as short and smooth as a well shaven grass-lawn. The part of the stems left by the scythe is not only lost, but the after-growth is neither so vigorous nor so weighty, as when the first cutting is taken as low as possible.

5546. *As soon as the swath or row of cut herbage is thoroughly dry above*, it is gently turned over (not tedded or scattered) without breaking it. Sometimes this is done with the hand, or with a small fork; and some farmers are so anxious to prevent the swath from being broken, that they only permit the use of the rake shaft. The grass, when turned over, in the morning of a dry day, is put into cocks in the afternoon. The mode of performing this is very simple and expeditious; and none but women, boys, and girls, under the eye of a confidential servant, are usually employed. If the crop is heavy, a row of cocks is placed in the middle ridge of three, and if light of five ridges. A distinct company of carriers and rakers is allotted to every such number of ridges; and the separate companies proceed each on its own ground, and in the same manner as in reaping grain, which occasions a degree of competition among them for despatch, clean raking, and neat well-built cocks. The carriers gather the hay, and carry it to the ridge where the cock is to be built by one of the most experienced hands. A raker follows the carrier, taking up and bringing to the cocks the remains of the swath. There may be, in general, about five people employed about each row of cocks; a carrier and raker on each side of the ridge on which the cocks are placed, and a person on the ridge, who builds them. But when the crop is not weighty, more rakers are required, and a greater space must be gone over.

5547. *As the cocks are thus placed in a line*, it is easy to put two or more into one afterwards; and the larger cocks may be speedily drawn together, to be put into tramp-ricks, by means of ropes thrown round their bottoms, and dragged along by a horse. It is impossible to lay down any rules for the management of hay, after it is put into cocks; one thing is, however, always attended to, not to shake out, scatter, or expose the hay oftener than is necessary for its preservation. Sometimes the cocks have been put up so large, that they never require to go to a tramp-rick, but are carted to the stack-yard, without ever being broken, and put up in alternate layers with old hay. But where this is attempted, there must not be much clover. The practice of mixing the new with the old hay is, however, a good one, and saves a great deal of time and labour, at the same time that the old hay is much improved by the mixture.

5548. *The best managers disapprove of spreading out the swathes of clover and rye-grass, though this is often necessary with natural grasses, which are cut and harvested later in the season. The more the swath is kept unbroken, the hay is greener, and the more fragrant.*

5549. *Another mode of hay-making, said to have been originally practised in Lancashire, has been found to answer well in the moist atmosphere of the west of Scotland. This is called tipping or rippling; and if the grass is dry, the operation begins as soon as it is mown. "In making a tipple, a person with his right hand rolls the swath inwards, until he has a little bundle; then the same is done by the left, until both meet and form eight to twelve pounds, or nearly so. This bundle is then set up against the legs, or between the feet; a rope is twisted of the grass, while the bundle is supported in this manner, and tied round it near its top; and from the top are drawn up a few straggling stems, which are twisted to make the tipple taper to a point, and give it as much a conical shape as possible. If the crop is strong, there is a row of tipples placed on each swath; if light, two of these are put into one row. After standing a few hours, they become so smooth on the outside, that the heaviest rains seldom wet them through; and when wet, they are soon dried again in good weather. As soon as ready, they are put into the summer-rick, or, if very dry, even into the winter stack, but are never opened out or tedded, to make them dry, as they never require it. By this method, not a blade is lost, and the hay is nearly as green as a leaf dried in a book. In a moderate crop, one woman will tipple to one mower, and a woman will rake to two tippers, or two swathers. But where the crop is strong, it may require three women to keep pace with two mowers. After the hay is put up in this manner, the crop may be considered secure, though it may continue wet weather for a considerable length of time." (General Report of Scotland, vol. ii. p. 11.)*

5550. *The making of clover hay, as practised in Courland, and adopted from that country in Silesia, is said to save not only a number of hands, but the hay is better and more nourishing. The hay is prepared by self-fermentation, whereby it retains its nutritious juices, and only loses its watery particles; it is dried more expeditiously by dissipation of its humidity, and contraction of the sap-vessels, and thus its nutritious juices are concentrated. The process is conducted on the following principle, viz. the sap-vessels are expanded by the circulation of the liquid juices by heat, and the superfluous humidity is exhaled: on cooling, the sap-vessels contract, and thus future intestine fermentation is prevented, and the nutritious quality is preserved.*

5551. *The clover intended for hay, after having been mowed, remains till four o'clock in the afternoon of the following day in swath to dry; it must then be raked together into small coils, and afterwards made into large cocks in the form of a sugar-loaf, and such as it would require six or eight horses to remove. To prevent the air from penetrating these cocks, and to produce a quicker fermentation, they must, whilst forming, be trodden down by one or two men. If it be a still, close, warm night, the fermentation will commence in four hours, and manifest itself by a strong honey-like smell: when proper fermentation is begun, the cocks will, on being opened, smoke, appear brownish, and may then be spread abroad. If in the morning the sun is warm, and a little wind arises, the clover-hay will quickly dry; it may then, towards noon, be turned with the rake or pitch-fork, and about four in the afternoon will be sufficiently dried, so that it may be immediately carted into the barn, without any danger of a second fermentation. By this method of management, the clover will require only three days, from the time of mowing to its being housed, and very little work; whilst, in the common way, even in good weather, it requires six or eight days. In the old method it frequently becomes of a black colour; but in the new method it is only brown, has an agreeable smell, and remains good and unchangeable in the barn. The farmer has also another advantage, that if he has not carts enough to carry it into the barn, he need only, at sun-setting, heap it again into large well trodden cocks, and thatch them with straw, in which state they will remain the whole summer without damage or loss. This clover-hay is not only greedily eaten by sheep and lambs, but also by horses, calves, and cows.*

5552. *This new mode of making hay depends principally upon two circumstances: first, that the mown clover, when brought together in to large heaps, may ferment equally and expeditiously; secondly, that the day succeeding the fermentation be dry, sunny, and windy: on this account it may be proper to point out what should be done when circumstances are unfavourable. Let us suppose, therefore, that the night after the clover-grass has been placed in the great cocks is cold, damp, or rainy, the fermentation will yet take place, although it may require a term of twelve, sixteen, or twenty-four hours to effect it. If it be a second or a third crop, at which season the nights are colder, it may even require from thirty-six to forty-eight hours before the fermentation ensues: it will, however, commence, and may be ascertained from this circumstance, that you can scarcely bear your hand in the interior of the cock. Even if the night be dry, yet if a strong cold wind blows, the cock may not ferment equally, but only in the middle, and on the side opposite to the wind; the other parts may still remain green. In such a case the following rules must be attended to:—*

5553. *Rule first.* If the cock has only fermented in the middle, and on that side where the cold wind did not act upon it, the whole heap must nevertheless be opened on the following morning. That which has already fermented must be separated and spread to dry; it must be turned towards noon, and may be carted into the barn in the evening; but that part of the cock which has not fermented must be again put together into large cocks, and fermented in the same manner as the preceding part, after which it may be spread to dry, and brought into the barn.

5554. *Rule second.* In such cases where a small portion of the cock has fermented thoroughly, but not the greater part, the heap must be spread abroad in the morning, but must be again made into a close cock in the evening, in such a manner that the part which has fermented be placed at the top or outside of the cock, and that which has not fermented be inclosed within it; then on the ensuing morning, or, if the weather be cold and rainy, on the morning afterwards, the clover-heap may be again spread abroad, and the clover treated as in the case first mentioned.

5555. *Rule third.* If, in spreading the heap abroad, it be found that nearly the whole of the clover has fermented, it will not be necessary to delay the housing of the whole on account of some small portion; but the clover may be dried and carted into the barn. The small portion which remained unfermented will not occasion any disaster to the other which has fermented; for there is a material difference betwixt hay thus managed, and the meadow-grass which is brought whilst damp, or wet with rain, into the barn, which will grow musty and putrid.

5556. *Rule fourth.* In such instances, where some of the cocks of clover have thoroughly fermented, and it rains on the morning, they ought to be spread abroad, for the clover must be opened and spread, even if it rains violently; since, if it were suffered to remain longer in the heap, it would take fire, or its juices would be injured by too much fermentation; the leaves and stalks would become black, and the clover unfit for food: therefore, if the rain continues, the spread clover must be turned from time to time, but not carted into the barn till dry. This drying takes place, if the rain discontinues for a few hours, much more expeditiously with the clover which has fermented, than with that made in the common way. Besides which, it must be remarked, that the fermented clover remains good, even if it continues some weeks exposed to the rain, provided it is at last suffered to dry before it is put into the barn; otherwise the wet from the rain will render it musty and bad. The clover which has been for so long a time exposed to the rain will not, however, be so nutritious as that which has been well fermented and sooner dried; but it will be far superior to that which has been exposed to the rain, and got up in the common method. (*Klapmeyer in Thaer's Annalen, &c.*)

5557. *Hay is stacked in circular or oblong stacks, the latter form being most generally approved of, and carefully thatched, as has been already observed in regard to corn. It is never advisable to allow this kind of hay to become heated in any considerable degree, in the stack, though a slight exudation, with a*

very gentle warmth, is usually perceptible, both in the field-ricks and in the stacks, for a few days after they are built. But this is a quite different thing from that intentional heating, carried so far, in many instances, as to terminate in conflagration.

5558. *The after-growth or second crop of clover* is vigorous or weak, according to the proportion of clover plants to rye-grass, to the time when the first crop was cut, and to the moisture and warmth of the season. When the first cutting has been made early for soiling, there will sometimes be three cuttings in one season. The first of these after-cuttings may be made into hay, and sometimes the second; but in general both are consumed by soiling or pasturing, unless in some dry warm districts, as Norfolk, and parts of Suffolk, Kent, &c., where the second growth is left to ripen its seed. In the northern counties the second crop is seldom made into hay, owing to the difficulty of getting it thoroughly dried at a late period of summer, when other more urgent operations usually employ all the labourers of a farm. If it is cut for this purpose, the best method of saving it is to mix it up with straw, which will absorb a part of its juices. It is often cut green, as a part of the soiling system; or, where a sheep stock is kept, pastures by the old ewes, or other sorts, that are to be fattened the ensuing winter on turnips.

5559. *In consuming clover and other herbage plants by pasturing*, or eating down on the spot, three methods have been adopted: tethering, hurdling, and free pasturage.

5560. *Tethering* may be considered a rude practice, and is chiefly confined to the north of Scotland and Ireland. In *The Agricultural Report of Aberdeenshire* it is stated, that there are some cases where the plan of tethering can be practised with more profit than even soiling. In the neighbourhood of Peterhead, for instance, they tether milk cows on their grass fields, in a regular and systematic method; moving each tether forward in a straight line, not above one foot at a time, so as to prevent the cows from treading on the grass that is to be eaten; care being always taken to move the tether forward, like a person cutting clover with a scythe, from one end of the field to the other. In this way, a greater number of cows can be kept, on the same quantity of grass, than by any other plan; except where it grows high enough to be cut, and given them green in houses. In one instance, the system was carried to great perfection, by a gentleman who kept a few sheep upon longer tethers, following the cows. Sometimes, also, he tethered horses afterwards upon the same field, which prevented any possible waste; for the tufts of grass produced by the dung of one species of animal will be eaten by those of another kind without reluctance. This system was peculiarly calculated for the cow-feeders in Peterhead; as, from the smallness of their holdings, they could not afford to keep servants to cut, or horses to carry home, the grass to their houses, to be consumed in a green state. (*Code.*)

5561. *In hurdling off clovers or herbage crops*, a portion of the field is enclosed by hurdles, in which sheep are confined; and as the crop is consumed, the pen is changed to a fresh place, until the whole is fed off. This practice is very extensively adopted at Holkham, and is peculiarly calculated for light and dry soils. Its advantages are, that the grass is more economically consumed; that the stock thrive better, having daily a fresh bite; and that the dung falls, being more concentrated, is more likely to be of use.

5562. *In the common pasturing of clover*, the stock are introduced into the field earlier than in tethering or hurdling, in order to avoid the loss that would be sustained by cattle or sheep treading *ad libitum* on tall herbage. Indeed, the principal advantage of pasturing clovers is, that sheep and lambs may be turned on them more early than on common grass-lands. Sometimes this advantage is taken for a month or six weeks, in the beginning of summer, and the field afterwards shut up for a crop of hay; but more frequently the red clovers are only mown. When white and yellow clovers are sown, the herbage is sometimes not mown at all, but pastured for three years or more; and sometimes a little red clover being sown along with these, a crop of hay is taken the first year.

5563. *The produce of clover-hay*, without any mixture of rye-grass, on the best soils is from two to three tons per acre, and in this state in the London market it generally sells 20 per cent. higher than meadow-hay, or clover and rye-grass mixed. The weight of hay from clover and rye-grass varies, according to the soil and the season, from one ton to three tons per English acre, as it is taken from the tramp-ricks; but after being stacked, and kept till spring, the weight is found to be diminished twenty-five or thirty per cent.

5564. *The value of clover and rye-grass hay*, in comparison with the straw of beans or peas, may be in the proportion of three to two; and with the finest straw of corn crops, in the proportion of two to one. One acre of red or broad clover will go as far in feeding horses or black cattle as three of ordinary pasture; and when it is cut occasionally, and given to them fresh, it will, probably, go still much farther, as no part of it is lost by being trodden down. With the exception of lucern, and the herbage of rich marshes, there is no crop by which so much stock can be supported as by clover. It may be profitably employed in fattening sheep in spring, and with this food they will soon be ready for the butcher. Afterwards, a crop of hay may be got, and two or three weeks after the hay has been taken off, sheep intended to be fattened on turnips may be turned in, and kept there, until the turnips are ready for them.

5565. *The nutritive products of clovers* will be found in the table. (5520.)

5566. *The saving of clover seed* is attended with considerable labour and difficulty. Clover will not perfect its seeds, if saved for that purpose early in the year; therefore it is necessary to take off the first growth either by feeding or with the scythe, and to depend for the seed on those heads that are produced in the autumn. Seed-clover turns out to good account in those years when the crops are not injured by the blight, which is often fatal to them, or by the rains in the autumn, which sometimes prove their destruction; for the time of harvesting this seed falling out late when rainy weather may be expected, renders it, on that account, very tedious.

5567. *When the first crop is fed off*, it is eaten till about the end of May, frequently by ewes and lambs; and this is understood to be an advantageous practice, because the land is less exhausted, and the green food is of great value for stock in the spring months. It is not uncommon, however, to cut the first growth for a hay crop, and this should be done earlier than usual. The growth thus reserved for seed must be suffered to remain till the husks become perfectly brown, when it is cut and harvested in the usual manner, leaving it on the field till it is very dry and crisp, that the seeds may become more fully hardened; it may then be laid up dry, to be threshed out at the farmer's convenience. Much labour and expense are necessary in separating the seed from the capsule or seed-coat, especially when it is effected by threshing, which seldom costs less than from five to six or seven shillings per bushel. By the use of mills the work may be done much cheaper,

5568. *The management of a crop of clover with a view to saving seed* is thus given by a cultivator in Buckinghamshire. A moderate bulk of haulm is generally found most productive of seed, and a moderately rich, sharp, dry soil is the best for having moderate haulm. The field may be pastured till the middle of May, and then shut up till the ripening is completed. August is generally the ripening month, and the maturity of the seed may be known by the leaves becoming brown and dropping off. Observe the seed from time to time, and when it has changed from a bright yellow to a deep purple, it is then ready for the scythe. After the crop is cut down, disturb it as little as possible by fork or rake. Form it into small cocks not larger than muck heaps. Should favourable weather ensue, nothing more is necessary than to turn these cocks once over, shortly before carting home. And, should the weather prove fickle, these small heaps of withered straw are very soon dried, perhaps in one good day, by turning up the bottom, after the top has become a little dried. After remaining some time in the field, the cocks subside considerably and become caked, by which the flowers adhere together and repel the rain; of course, no loss of top can be sustained by gently turning them to dry. It thus appears, that clover for seed is not so liable to be injured as clover for hay. In general six or ten days of favourable weather render it fit to carry to the rick-yard and stack. It may either be threshed by a light flail, or by threshing machines, having a particular additional cover introduced below the drum or beater for that purpose.

5569. *In threshing*, whether by the flail or machine, the first operation is to separate the heads or spikes of seeds from the haulm. This operation separates none of the seed, which remains firm in the withered florets, and requires to be separated by a course of light thrashing, similar to that used for hummelling barley. When on examination it is found that the seed is all separated, the operations of sifting and winnowing ought to be carried on in the usual manner with appropriate sieves; the clover sieve being well known to the sieve-maker. The average produce per acre is three hundred weight.

5570. *Seed may be saved from a second crop*; that is, after the first crop has been mown for hay; but the sample is seldom so strong or plump as that from a first crop.

5571. *White clover*, and also yellow clover, lucern, and saintfoin, when intended for seed, are treated much in the same manner as red clover. (*Farm. Mag.* vol. xix. p. 276.)

5572. *The produce in seed* may generally be from three to four or five bushels per acre, when perfectly clean, weighing from two to three hundred weight. But there is great uncertainty in the produce of clover seed, from the lateness of the season at which it becomes ripe; and the fertility of the soil is considerably impaired by such a crop. Yet the high value of the seed is a great inducement to the saving of it, in favourable situations. (*Dickson's Practical Agriculture*, vol. ii. p. 863.)

5573. *The diseases of clover* are the blight or mildew, and suffocation or consumption, from insects, slugs, and worms. It often happens that clover, after being repeated at short intervals on the same soil, either fails or does no good; whether that is owing to a disease, or to a defect of some peculiar substance which enters into the food of the plant, does not appear to be clearly ascertained. A top-dressing with ashes or lime is said to be unfavourable to the slug; but where vermin of this sort are very numerous, the most certain remedy is a naked fallow well worked in the hottest months.

SECT. II. *Lucern*. — *Medicago sativa* L.; *Diadélphia Decándria* L., and *Leguminosæ* J. *La Lucerne*, Fr.; *Futterklee*, Ger.; *Medica*, Ital.; and *Mielga* Span. (fig. 775.)



5574. *Lucern* is a deep-rooting perennial plant, sending up numerous small and tall clover-like shoots, with blue or violet spikes of flowers. It is a native of the south of Europe, and appears to be acclimated in the warmer parts of England. Lucern or medic is highly extolled by the Roman writers, and also the cytissus, the latter a low evergreen shrub. Lucern is much grown in Persia and Lima, and mown in both countries all the year round; it is also of unknown antiquity in old Spain, Italy, and the south of France. It was introduced to England from the latter country, according to Miller, in 1657. It is mentioned by Hartlib, Blythe, and other early writers, and was tried by Lisle; but it excited little attention till after the publication of Harte's *Essays*, in 1757. It is now only cultivated in a few places, and chiefly in Kent. Columella estimated lucern as the choicest of all fodder, because it lasted many years, and bore being cut down four, five, or six times a year. It enriches, he says, the land on which it grows, fattens the cattle fed with it, and is often

a remedy for sick cattle. About three quarters of an acre of it is, he thinks, abundantly sufficient to feed three horses during the whole year.

5575. *Clover* has found no great reception in this country, though it was so much esteemed by the ancients, and has been long cultivated to advantage in France and Switzerland. If any good reason can be given for this, it is, that lucern is a less hardy plant than red clover, requires three or four years before it comes to its full growth, and is for these and other reasons ill adapted to enter into general rotations. Where the climate and soil suit, perhaps a field of it may be advantageously sown, adjoining the home-stall, to afford early cutting or food for young or sick animals, for which it is said to be well adapted; but though it will produce good crops for eight or ten years, yet from the time the farmer must wait till this crop attains its perfection, and from the care requisite to keep it from grass and weeds, we do not think it is ever likely to come into general culture. The Highland Society have lately offered premiums for the culture of this plant in Scotland, and crops have been produced in dry sandy soils in the neighbourhood of Edinburgh; the climate, however, and the alternate and convertible system of culture generally pursued in the northern parts of the island, and which seems so well adapted to its agricultural circumstances, forbid the hope that it can ever become general.

5576. *There are no varieties of the lucern deserving the notice of a cultivator.*

5577. *What is called the yellow lucern is the Medicàgo falcàta (Lucerne en famille, or Luzerne de Suède, Fr. fig. 776.), a much hardier and coarser plant, common in several parts of England, but not cultivated any where except in some poor soils in France and Switzerland.*

776



5578. *Medicàgo maculàta and muricàta are cultivated in France, but to a very limited extent on poor soils. M. lupulina (lupuline, or Minette dorée, Fr.) resembles our well known hop trefoil, black (from its seeds) nonsuch, or yellow clover; but it is seldom cultivated in Britain.*

5579. *The soil for lucern must be dry, friable, inclining to sand, and with a subsoil equal to it in goodness. Unless the subsoil be good and deep, it is in vain to attempt to cultivate lucern. According to Young, the soils that suit lucern are all those that are at once dry and rich. If, says he, they possess these two criteria, there is no fear but they will produce large crops of lucern. A friable deep sandy loam on a chalk or white dry marly bottom is excellent for it. Deep putrid sand warp on a dry basis, good sandy loam on chalk, dry marl or gravel, all do well; and in a word, all soils that are good enough for wheat, and dry enough for turnips to be fed on the land, do well for lucern. If deficient in fertility, they may be made up by manuring,*

but he never yet met with any land too rich for it.

5580. *The preparation of the soil consists in deep ploughing and minute pulverisation; and, in our opinion, the shortest way to effect this, is to trench it over by the spade to two or three feet in depth, burying a good coat of manure in the middle or at least one foot from the surface. This is the practice in Guernsey, where lucern is highly prized.*

5581. *The climate for lucern, as we have already hinted, must be warm and dry; it has been grown in Scotland and Ireland, and might probably do well in the southern counties of the latter country, but in the former it has not been found to answer the commendations of its admirers.*

5582. *The season most proper for sowing lucern is as early as practicable in the spring months, as in this way the plants may be fully established before the season becomes too hot. The latter end of March, for the more southern districts, may be the most proper period; and the beginning of the following month for those of the north. When sown late, there is more danger of the plants being destroyed by the fly, as it has been observed by Tull. If the plants are intended to be transplanted out in the garden method, it will also be the best practice to sow the seed-bed as early in the spring as the frosts will admit, in order that they may be strong, and fit to set out about the beginning of August.*

5583. *The manner of sowing lucern is either broad-cast or in drills, and either with or without an accompanying crop of corn for the first year. Broad-cast, with a very thin crop of barley or other spring corn, is generally, and in our opinion very properly, preferred. Arthur Young, who has treated largely on this plant, observes, that "the greatest success by far that has been known is by the broad-cast method, which is nearly universal among the best lucern farmers, even among men who practise and admire the drill husbandry in many other articles. But as they mostly (not all) depend on severe harrowing for keeping their crops clean, which is a troublesome and expensive operation, he still ventures to recommend drilling; but very different drilling from that which has been almost universally practised, viz. at distances of eighteen inches or two feet. Objections to these wide intervals are numerous. If kept clean hoed, the lucern licks up so much dirt, being beaten to the earth by rain, &c., that it is unwholesome, and the plants spread so into these spaces, that it must be reaped with a hook, which is a great and useless expense. For these reasons, as well as for superiority of crop, he recommends drilling at nine inches, which in point of produce, mowing, and freedom from dirt, is the same as broad-cast; and another advantage is, that it admits scarifying once a year, which is much more powerful and effective than any harrowing. These facts are sufficient to weigh so much with any reasonable man, as to induce him to adopt this mode or drilling, as nearer to broad-cast by far than it is to drills at eighteen to twenty-four inches, which open to a quite different system, and a set of very different evils. Nine-inch rows might practically, but not literally, be considered as broad-cast, but with the power of scarifying. And in regard to the material point, of with or without corn, two considerations, he says, present themselves. One is the extreme liability of lucern to be eaten by the fly, which does great mischief to many crops when very young, and against which the growing of corn is some protection. The value of the barley or oats is another object not to be forgotten. It is also gained in the first year's growth of the lucern, which is very poorly productive even if no corn be sown; so that he must own himself clearly an advocate for drilling in among corn, either between the rows of nine-inch barley, or across drilled barley, at a foot, if perhaps the latter is the best method, as there is less probability of the crop being laid to the damage of the lucern. The quantity of seed-corn should also be small, proportioned to the richness of the land, from one bushel to a bushel and a half, according to the fertility of the soil; another security against the mischief of lodging. If these precautions are taken, it would be presumptuous to say that success must follow, that being always, and in all things, in other hands than ours; seed may prove bad, the fly may eat and drought prevent vegetation; but barring such circumstances, the farmer may rest satisfied that he has done what can be done, and if he do succeed, the advantage will be unquestionable."*

5584. *The quantity of seed, when the broad-cast method is adopted, is said to be from fifteen to twenty pounds per acre, and from eight to twelve if drilled. The seed is paler, larger, and dearer than that of clover: it is generally imported from Holland, and great care should be had to procure it plump and perfectly new, as two-years-*

old seed does not come up freely. The same depth of covering as for clover will answer.

5585. *Lucern may be transplanted*, and when the soil is very rich and deep, it is said to produce very large plants; but such plants, from the bulk of their stools, are not likely to be so durable as those of a less size; and on the whole, for this reason and others relative to expense, the plan of transplanting does not seem advisable unless for filling up blanks.

5586. *The after-culture of lucern*, sown broad-cast, consists in harrowing to destroy grass and other weeds; rolling, after the harrowing, to smooth the soil for the scythe; and such occasional top-dressings of manure as the state of the plants may seem to require.

5587. *When lucern is drilled*, horse-hoeing may be substituted for harrowing, which, as already observed, is the only advantage of that mode of sowing. The harrowing may commence the second year, and the weeds collected should always be carefully removed: light harrows may be used at first, and in two or three years such as are heavier. In succeeding years two harrowings may be required, one early in the spring, and the other at the close of the summer. For these, and especially the last, Arthur Young recommends the use of a harrow of weight sufficient for four horses, and which does not cover a breadth of more than four feet. The mode of hoeing, either by the hand or horse-hoe, or of stirring by the drill harrow, requires no description.

5588. *The top-dressings* given to lucern may be either of the saline or mixed manures. Ashes are greatly esteemed, and also gypsum and liquid manure of any kind. Arthur Young advises to apply dung, in the quantity of about twenty tons to the acre, every five or six years. Kent, however, thinks it a better practice to put a slight coat on annually in the spring season. Some recommend a slight top-dressing sown by hand every spring. The farmer will in this, as in every case, exercise his own judgment, and be guided by the wants of the plants, the return they yield for the expense bestowed on them, and the equable distribution of manure among his other crops.

5589. *The taking of lucern* by mowing for soiling, or hay, or by tethering, hurdling, or pasturing, may be considered the same as for clover. Lucern frequently attains a sufficient growth for the scythe, towards the end of April, or beginning of the following month; and, in soils that are favourable for its culture, will be in a state of readiness for a second cutting in the course of a month or six weeks longer, being capable of undergoing the same operation, at nearly similar distances of time, during the whole of the summer season. In this last sort of soil, with proper management, in the drill method, it has been found to rise to the height of a foot and a half in about thirty or forty days, affording five full cuttings in the summer. But in the broad-cast crops, in the opinion of some, there are seldom so many cuttings afforded in the season, three or four being more common, as the growth is supposed to be less rapid than by either of the other modes.

5590. *The application of lucern* is also the same as that of clover. The principal and most advantageous practice is that of soiling horses, neat cattle, and hogs: but as a dry fodder, it is also capable of affording much assistance; and, as an early food for ewes and lambs, may be of great value in particular cases. All agree in extolling it as food for cows, whether in a green or dried state. It is said to be much superior to clover, both in increasing the milk and butter, and improving its flavour. In its use in a green state, care is necessary not to give the animals too much at a time, especially when it is moist, as they may be hoven or blown with it, in the same way as with clover, and other green food of luxuriant growth.

5591. *The produce of lucern*, cut three times in a season, has been stated at from three to five and even eight tons per acre. In soiling, one acre is sufficient for three or four cows during the soiling season; and a quarter of an acre, if the soil be good, or half an acre on a moderate soil, for all sorts of large stock, for the same period. Say, however, that the produce is equal in bulk and value to a full crop of red clover, then, if continued yearly for nine or ten years (its ordinary duration in a productive state), at an annual expense of harrowing and rolling; and a triennial expense of top-dressing, it will be of sufficient value to induce farmers, who have suitable soils and climates, to lay down a few acres under this crop near their homestalls.

5592. *The nutritive product of lucern*, according to Sir H. Davy, is $2\frac{3}{10}$ per cent., and is to that of the clovers and saintfoin as 23 to 39. This result does not very well agree with the superior nutritive powers attributed to lucern.

5593. *To save seed*, the lucern may be treated precisely as the red clover, and it is much more easily threshed, the grains being contained in small pods, which easily separate under the flail, or a threshing machine, or clover mill.

5594. *The diseases of lucern* appear to be the same as those of clover. In Kent, blight and the slug are its greatest enemies.

SECT. III. *Saintfoin*. — *Hedysarum Onobrychis* L. ; *Diadélphia Decándria* L., and *Leguminosæ* J. *Bourgogne*, or *Esparcette*, Fr. ; *Espartzette*, Ger. ; *Cedrangola*, Ital. ; and *Esparsita*, Span. (fig. 777.)

5595. *Saintfoin* is a deep-rooting perennial with branching spreading stems, compound

777



leaves, and showy red flowers. It is a native of England and many parts of Europe, but never found except on dry, warm, chalky soils, where it is of great duration. It has been long cultivated in France and other parts of the Continent, and as an agricultural plant was introduced from France to England about the middle of the seventeenth century. It has since been a good deal cultivated in the chalky districts ; and its peculiar value is, that it may be grown on soils unfit for being constantly under tillage, and which would yield little under grass. This is owing to the long and descending roots of the saintfoin, which will penetrate and thrive in the fissures of rocky and chalky understrata. Its herbage is said to be equally suited for pasturage and for hay, and that eaten green it is not apt to swell or hove cattle like the clovers or lucern. Arthur Young says, that upon soils proper for this grass no farmer can sow too much of it ; and in *The Code of Agriculture* it is said to be “ one of the most valuable herbage

plants we owe to the bounty of Providence.”

5596. *There are no varieties* of the saintfoin in England, but many other species of the same numerous family might be cultivated, such, for example, as the French honeysuckle, a biennial that might be substituted for red clover on rich soils. The French have a variety which they call *Sainfoin à deux coupes*, and they also cultivated the *Sainfoin d’Espagne* or *Sulla*.

5597. *The best soil* for this plant is that which is dry, deep, and calcareous ; but it will grow on any soil that has a dry subsoil. Kent thinks that the soils most suited to the culture of this sort of grass are of the chalky loam, and light sandy or gravelly kinds, or almost any of those of a mixed quality, provided they are sufficiently dry, and have a rocky or hard calcareous bottom to check the roots at the depth of a foot or fifteen inches below the surface, which he conceives necessary, as the plants are apt to exhaust themselves in running down ; and for this reason he considers it improper for being sown where there is great depth of mould or soil. It is a plant that is asserted by Marshal to afford a large produce even on those soils which are of the poorest quality, and on such as are of a more rich and friable nature to frequently produce abundant crops. Still, he conceives, that it is only in the calcareous soils, as the dry chalk and limestone, or such as have been well impregnated with that sort of matter, that it succeeds in a perfect manner or becomes durable. The advantages resulting from growing this plant on sandy soils in Norfolk have been already stated. (4744.)

5598. *The best preparation* which any soil fit for this plant can undergo is, unquestionably, trenching ; and we have little doubt that in most cases, all things considered, it would be found the cheapest. The usual preparatory culture, however, is the same as for clover, ploughing more deeply than ordinary, either by means of the trench plough, or, what is better because more simple, by the common plough going twice in the same track. Boys (*Communications to the Board of Agriculture*, vol. iii.) recommends as a preparation for saintfoin : 1st year, pare and burn for turnips, to be eaten on the land by sheep, with the aid of some fodder ; 2d, barley, to be sown very early with clover seed ; 3d, clover eaten off by sheep ; 4th, wheat ; 5th, turnips with manure ; and, 6th, barley with saintfoin. The corn crops must be carefully weeded, and in particular cleared of charlock. Under this system, the produce has been great, and the ground has been laid down in the highest order with saintfoin, or any other grass calculated for this species of soil.

5599. *With respect to the season of sowing* saintfoin, it may be observed, that the earlier it can be put into the soil in the spring the better, as from the greater moisture of such soils there will be a greater probability of its vegetating in a perfect manner. Where the sowing is executed at a late period, and dry weather succeeds, Bannister thinks that much of the seed is prevented from growing, and that the young plants are more exposed to destruction from the fly ; therefore, according to this writer, the sowing of saintfoin seed ought never to be deferred longer than the beginning of March, and it is still better to complete this work in February. Some, however, suppose it may be deferred to the middle of March without injury, and this is soon enough if it is to be sown with barley.

5600. *The manner of sowing* is generally broad-cast ; but it may be sown in drills and even transplanted, though neither of these modes can be recommended. Some advise its being sown with about half the quantity of barley usually sown for a full crop, which may shade and keep it moist during the first summer, and at the same time not injure it from the crop being lighter, which is sometimes the case. Where the barley is drilled, the saintfoin may afterwards be put in, in the same manner, but in a contrary direction. If sown over the wheat, it should be harrowed in, and afterwards rolled. In whatever method it is sown, as the seeds are larger than those of many other herbage plants, they should be covered in with more care, and to a somewhat greater depth. By some the ploughing of the seed in with a very thin or shallow

furrow is recommended. In most cases, especially in all the more light sorts of land in which this sort of erop is grown, the use of the roller may be necessary immediately after the seed is put into the ground. It is the practice in some districts to sow a small portion of clover seed with saintfoin, with the idea of increasing the first year's produce; but as plants of different kinds seldom answer well when grown together, from there being a continual contest in their growth for an ascendancy, it is perhaps a better method to increase the proportion of the seed, without mixing it with that of other sorts. It is, however, supposed by Marshal that such a practice is beneficial in ultimately procuring a fine clean erop of saintfoin upon the land. It is a sort of crop that grows in so perfect a manner in the broad-east method, that there can seldom be any necessity for having recourse to the drill. It may, however, be cultivated in the latter mode with much success; and, in Norfolk, it is the practice with some cultivators to have it drilled at nine inches across the barley crops which have been sown in the same way.

5601. *The quantity of seed* in the broad-east method, which is that mostly employed, is about four bushels the acre, though less is frequently given; but on such soils as are proper for this plant it is always necessary to have a full proportion of seed. By some, however, a much smaller quantity is made use of; and where the drill system is had recourse to, a still smaller proportion is used, as from two to two and a half or three bushels. It has been observed, that in Lincolnshire, where this plant is much grown, "the common allowance of seed is five bushels to an acre, and that a gentleman south of Lincoln advises the sowing a small quantity of trefoil with it (about four pounds on an acre)." The reason for this is, that in that exposed country, the young plants suffer more by the sun in summer than by the frost in winter. Of course the trefoil coming to perfection the first year, and living only three, will be a shelter for the young plants during the first year or two, and die off when the saintfoin wants its room.

5602. *In the choice of the seed* the safest practice for the cultivator is to select it from the best and most abiding plants in this particular soil, as that purchased from the seed-shops can rarely be depended upon. A certain method of knowing the goodness of the seed is, by sowing a number of the seeds, and seeing how many plants are produced by them. But the external signs of the seeds being good are, that the husk is of a bright colour, and the kernel plump, of a light grey or blue colour, and sometimes of a shining black. The seed may be good, though the husk be black, as that is owing sometimes to letting it receive wet in the field, and not to its being half-rotted in the heap. If the kernel on being cut across appears greenish and fresh, it is a certain sign that it is good: but if it is of a yellowish colour, and friable, and looks thin and pitted, it is a bad sign. Others observe that the best seed is plump, heavy, bright, and of a yellowish red colour, and that it should always be sown while quite fresh, as old seed, or seed that has been long kept, never vegetates in a perfect manner; seed of this sort is in general from about three to five shillings the bushel.

5603. *The after-culture and management of saintfoin* consists in occasional dressings with manure, and, in the judicious intervention of mowing and pasturing.

5604. *Some farmers do not mow in the first year*, while others do; but in the second year, and in the succeeding summers, a crop of hay may be taken, and the after-grass fed down with any sorts of stock but sheep, till towards December. These should not be permitted to eat it too close, as, from the largeness of the roots, they might by so doing injure the crowns of the plants. In the following autumn there will, however, be less risk in this respect, and sheep as well as cattle stock may be turned in and kept upon the pastures till they are well eaten down, being always careful to shut them up as early as possible in the beginning of the year. This is the opinion of Kent. As this sort of herbage is thought to be improved in its taste by being nipped by the frost, it may be a proper practice not to turn stock upon these leys too early in the autumnal season; perhaps not before the latter end of September, when this sort of rouen or after-grass will be found to have much effect in promoting the flow of milk in cows, as well as in forwarding the condition of fattening beasts; great store of feed being still left for sheep. But with this sort of stock they should not be too closely fed down, nor should the sheep remain too long upon them. It has been suggested that all sorts of cattle stock should be removed by the beginning of the year from these rouens, as much harm might be done by their continuing longer.

5605. *In top-dressing saintfoin* peat-ashes are the best material that can be made use of where they can be procured in sufficient quantity; and other sorts of ashes are likewise found beneficial where these cannot be had. They should be applied so as to form a thin, even, regular dressing over the whole surface of the crop. In this view soot has also been found of great utility when spread evenly over such leys about the beginning of January, in the proportion of about twenty-five or thirty bushels to the statute acre; and malt-dust has been employed in the same way with great success and advantage, as shown by Bannister in his *Synopsis of Husbandry*. It is supposed that where those sorts of top-dressings can be applied every third or fourth year, the saintfoin erops, when well established in the soils, may be preserved in a state of vigorous growth for ten or fifteen years, or more, and the land be considerably improved by the roots striking so deeply into it.

5606. *In taking and using the saintfoin crop*, the same practices may be followed as in taking clover: it may be mown for soiling, hay, or seed; and eaten on the spot by tethering, hurdling, or common pasturing.

5607. *In making it into hay*, it is cut immediately on its coming into full blossom, and as it remains but a short time in this state, as much expedition as possible should be employed both in mowing and making the produce into hay. It is remarked by the author of *The Synopsis of Husbandry*, who resides in a district where the culture of saintfoin is frequent, that of all other hay plants, it requires the least pains in making. When the season is favourable, the hay-makers may follow the scythe, and having turned over the swaths, throw them into wind-rows the succeeding day after the crop is mown, when it may be immediately formed into cocks, and the whole erop be fit for carting in a week, sometimes in three days after it is mown. Though it may appear very green, and the stack when made take on or acquire a considerable degree of heat, there is no danger to be apprehended, provided the weather has been fair during the hay-making; as it is so far from taking harm by heating in the stack, that the contrary state is the most to be feared. For this reason great care is necessary not to suffer the fodder to continue long either in the swath or in cocks, lest the sun and wind should dry it up too fast, and by exhaling its juices prevent the heating in the stack, and thereby render it of little value. In order to preserve its succulence, in some places they put a number of these cocks together, so as to form large cocks of a size to contain a load in each, and they finish the stacks out of the cocks. It is likewise a practice with many farmers, where the erop is slight, to turn the swaths, and then run them into cocks with a three-pronged barley fork, following with a wooden dew-rake, the head of which is of sufficient width to cover the ground occupied by three or four swaths, in this manner proceeding with the utmost despatch, and saving a deal of labour and expense in the business.

5608. *In regard to the frequency of cutting saintfoin*, it is probable that on the thinner sorts of soils it can seldom be done more than once; but on those of the deeper sorts two crops may sometimes be taken, in the same manner as with clover, care being taken in these cases that the future growth of the plants be not injured by this means.

5609. *The usual duration of saintfoin*, in a profitable state, is from eight to ten years. It attains its perfect growth in about three years, and begins to decline towards the eighth

or tenth on calcareous soils, and about the seventh and eighth on gravels. There are instances, however, of fields of saintfoin, which had been neglected and left to run into pasture, in which plants have been found upwards of fifty years from the time of sowing. It has been cultivated upwards of a century on the Cotswold Hills, and there roots of it have been traced down into stone quarries from ten to twenty feet in length, and in Germany Von Thaer found them attain the length of sixteen feet. In general the great enemy to the endurance of saintfoin is the grass, which accumulates and forms a close turf on the surface, and thus chokes up the plant.

5610. *The quantity of produce* in the state of hay, on a medium of soils and cultivation, may probably be estimated at from about one and a half to two tons the acre; and on the poorer and thinner staple sorts of land it will, perhaps, seldom afford less than from a ton to a ton and a half on the acre.

5611. *The nutritive products of saintfoin* are the same as clover; viz. $3\frac{3}{10}$, being $1\frac{6}{10}$ per cent more than those of lucern.

5612. *In saving seed* from saintfoin, it should remain on the land till the husks become of a somewhat brownish colour, and the seeds are perfectly plump and firm; as by these means they will not only be better in their quality, but be in less danger of being injured in the field, from the very short time that it will be necessary for them to remain, and also less in danger of being hurt by heating when laid up for future use. It has been stated, that it requires some experience to know of what degree of ripeness it is best to cut the seeded saintfoin, because all its seeds do not ripen at the same time. Some ears blossom before others; and every ear begins to blossom at its lower part, and continues to blow gradually upwards for many days; so that before the flower is gone off at the top, the seeds are almost mature at the bottom. From this cause, if the cutting be deferred till the top-seeds are quite ripe, the lower, which are the best, would shed and be lost.

5613. *The best time to cut it* is when the greater part of the seed is well filled, the first blown ripe, and the last blown beginning to be full. The unripe seeds will ripen after cutting, and be in all respects as good as those that were ripe before. Some, for want of observing this, have suffered their saintfoin seed to stand till all of it has shed, and been lost in cutting. Saintfoin should never be cut in the heat of the day, while the sun shines out; for then much, even of the unripe seed, will shed in mowing. The right time for this work is the morning or evening, when the dew has rendered the plants supple. When the weather is fine and clear, the saintfoin will soon dry sufficiently in the swaths, without turning them; but if any rain has fallen, and there is a necessity for turning them, it should be done very gently while they are moist, and not with two swaths together, as in hay made of saintfoin before it has seeded. If the swaths are turned with the handle of the rake, it is best to raise up the ear-sides first, and let the stub-side rest on the ground in turning; but if it is done with the teeth of the rake, let the stub-side be lifted up, and the ears rested on the earth. If it be cocked at all, the sooner it is done the better; because, if the swaths are dry, much of the seed will be lost in separating them, the ears being entangled together. When moist, the seeds stick fast in the ear; but when dry, they drop out with the least touch or shaking. It is, however, the best practice, as soon as the proper degree of maturity has been attained by the crop, to mow it in as short a time as possible, and let it remain exposed in the swath until the upper surface is fully dried, when it must be wholly turned over, but in a very careful manner, so as to prevent the seeds from shedding and being lost. When this side has been rendered perfectly dry and crisp in the same way as the other, the crop should either be threshed out upon cloths in the field where it is grown, or laid up in stacks to be afterwards threshed when the farmer has more leisure and convenience for the work.

5614. *The work of threshing out the seeds* in this kind of crop is much less troublesome and expensive than in the clover kind. In cases where threshing-machines are in use, the business may be executed by them with great ease and facility. It has, however, been observed by a late writer, that "when the season is favourable, the practice of threshing it out in the field is probably the most beneficial, as the stems or haulm may be laid up for the purpose of fodder in the stack."

5615. *As the threshing in the field* cannot be done but in very fine weather, and while the sun shines in the middle of the day, the best manner of performing it is to have a large sheet pegged down to the ground, for two men to thresh on with their flails, while two others bring them fresh supplies in a smaller sheet, and two more clear away the hay that has been threshed. The seed is emptied out of the larger sheet, and riddled through a large sieve, to separate it from the chaff and broken stalks; after which it is put into sacks, and carried into the barn to be winnowed. Care should be taken not to let the hay get wet, as in that case it would be spoiled. It is a very important, but difficult matter, to keep the seed that has been threshed in the field from becoming wet. If it be winnowed immediately, and laid in a heap or put into a sack, it will ferment to such a degree in a few days that the greater part of it will lose its vegetative quality. During that fermentation it will be very hot, and smell sour. Spreading it upon a barn-floor, though but seven or eight inches thick, will answer no end, unless it be frequently and regularly turned until the heating is over: but even this will not make its colour keep so bright as if it were well housed, well dried, and threshed in the winter. Laid up unthreshed it will keep without any danger of spoiling, because it does not lie close enough to heat. The best way to preserve the seed threshed in the field is to place a layer of straw upon a barn-floor, and upon that a thin layer of seed; then another layer of straw, and another layer of seed; and so on. By this means the seed, mixing with the straw, will be kept well, and come out in the spring in as fresh colour as when it was put in.

5616. *In respect to the produce in seed*, it is said to be usually "from about four to five sacks in some districts, but in others it will probably be much less, especially on the shallower sorts of saintfoin soils." But this must obviously be liable to great variation from seasons, &c.

5617. *The diseases of saintfoin* are few, there being little danger of failure after it has escaped the fly, which attacks the clover tribe in germinating.

SECT. IV. *Various Plants (not Gramineæ) which are or may be cultivated as Herbage and for Hay.*

5618. Among the inferior herbage plants which are occasionally cultivated, are burnet, ribwort, furze, and spurry. Those which might be cultivated are very numerous, and includes several species of *Vicia*, *Láthyrus*, *Galèga*, *Lòtus*, *Trifòlium*, *Medicàgo*, and others of the native *Legumindsæ*, or pea-like flowering plants; and *Achillèa*, *Alchemilla*, *Cheiránthus*, *Spártium*, *Àpium*, and a variety of others of different families. With the exception of the chiccory and furze, there are none of these plants that deserve the attention of the professional farmer; ribwort and burnet are occasionally sown; but they are of little value as hay plants, and in most pastures their place might be more advantageously occupied by one or other of the natural grasses. With respect to the other plants enumerated, they have never been tried but by way of experiment, and are only mentioned as resources under peculiar circumstances, and as a field of enquiry and exertion for the amateur cultivator.

5619. The burnet (*Pimprenelle grande*, Fr.; *Potèrium Sanguisórba* L. fig. 778.) is a native plant, a hardy perennial with compound leaves, blood coloured flowers, and a long tap-root. It was originally brought into notice by Roque, a commercial gardener, at Wallham green, near London, who found means to procure the patronage of the Dublin and other societies to this plant, which, being a novelty, attracted the attention and called forth the eulogies of Arthur Young, and other leading agriculturists of the day. Miller, however, at the time observed, that whoever will give themselves the trouble to examine the grounds where it naturally grows, will find the plants left uneaten by the cattle, when the grass about them has been cropped to the roots; besides, in wet winters and on strong land, the plants are of short duration, and therefore very unfit for the purpose of pasture or hay, nor is the produce sufficient to tempt any persons of skill to engage in its culture.



5620. Curtis says of burnet, that it is one of those plants which it has for some years past been attempted to introduce into agriculture; but not answering the farmer's expectation, it is now in a great degree laid aside. Cattle are said not to be fond of it; nor is its produce sufficient to answer the expense attending its culture. It is to be lamented that persons do not pay a little attention to the nature of plants before they so warmly recommend them. A small plant, scarcely ever met with but on hilly and chalky ground, and to which cattle in such situations do not show any particular attachment, is not likely to afford better or more copious nourishment than the clovers and other plants already in use.

5621. According to Boys, in *The Agricultural Survey of Kent*, it affords herbage in the winter and spring months, but is not much liked either by cattle or sheep.

5622. Dr. Anderson reports, that burnet retains its verdure pretty well during the winter months, but affords such scanty crops as hardly to be worth the attention of the farmer.

5623. A correspondent in the *Musèum Rústicum*, a work very favourable to burnet, confesses with reluctance that it is not deserving of any exalted character, but rather the contrary; and that it is in no degree to be compared to the common clover, which is cultivated at half the expense. It appears from some accounts there that horses will not eat it at all, and that kine frequently will not take it without great reluctance. Its slow growth is also made a great objection: being only about five inches high, and having scarcely one head in flower; whilst lucern, on the same soil, sown the same day and much thicker, was eighteen or twenty inches in height. It is not meant by this, however, to discourage that laudable spirit of improvement which so happily prevails at present; but to caution such as introduce any new plant to make themselves well acquainted with its natural history.

5624. Those who wish to cultivate burnet, as an herbage and hay plant, may treat it exactly as directed for saintfoin: as a pasture plant it is sown among the grasses in the same way as white or yellow clover. A bushel of seed is commonly sown to an acre.

5625. The ribwort plantain (*Plantain des Près*, Fr.; *Plantàgo lanceolàta* L., fig. 779.) is a hardy native with a tuft of long ribbed leaves springing from the crown of the root, long naked flower-stems, and a long moniliform tap-root. It abounds in dry soils, as do several other species of plantain, especially the *P. mèdia*. On dry soils it affords little herbage, and is often left untouched by cattle. Curtis, Withering, and other British botanists, speak unfavourably of the ribwort as a pasture herb; but Haller attributes the richness of the milk in the Swiss dairies to the flavour of this plant, and that of the *Alchemilla*, in the mountain pastures. In rich moist or watered lands its herbage is more abundant, and its flavour altered, — a circumstance not uncommon in the vegetable kingdom, but from which it does not always follow that the plant so altered is deserving of culture. In conformity with this observation, though the ribwort is a scanty and rejected herbage, on poor dry soils, it is said by Zappa of Milan to grow spontaneously in every meadow of Lombardy, especially in those which are irrigated. It vegetates early, flowers at the beginning of May, ripens in five weeks, and is cut with the *P. à triviàlis*; the height of the leaves is about one foot, and of the stalk a foot and a half; it multiplies itself much by the seed, and a little by the roots, which it continues for some time to reproduce. Ribwort, more especially in a cultivated state, is eaten heartily by every sort of cattle, and in particular by cows, who like it most in May, when it has great influence on the milk, as the hay has on the flesh. In Scotland it is a useful addition to the proper grasses on lands to be pastured by sheep, at the rate of two or three head to the acre. Where kept well fed down by stock, there can be no doubt of its being a very good and nourishing pasturage plant for both cattle and sheep; but it is by no means adapted for hay or soiling.



5626. Young says, that he had long before recommended this plant for laying land to grass, and sowed it on his own farm. At the same time, he thinks it extravagant to propose dandelion and sorrel as plants

proper for a cow pasture, and conjectures that those plants, being found among good ones, have qualities given them which do not properly belong to them: he is likewise inclined to make the same conjecture in respect to narrow-leaved plantain, ribwort, or rib-grass, and should even have preferred dandelion and sorrel to it; but he is cautious of opposing theory to practice.

5627. *Dr. Anderson* states, that narrow-leaved plantain or rib-grass is well liked by horses and cattle, and yields a very good crop upon rich ground tending to dampness, if it is at the same time soft and spongy; but that upon any soil which has a tendency to bind, or upon dry ground, it furnishes a very scanty crop. It has been made use of in some parts of Yorkshire as a summer grass. As an article of pasturage for cattle and sheep, it is there in high esteem: it is not, however, well eaten by horses. As an article of hay, it is held to be detrimental to the crop; retaining its sap an unusual length of time, and when fully dry falling into a small compass, or being broken into fragments and left behind in the field.

5628. *The culture of the plantain is the same as that of clover; its seed is about the same size, and consequently the same proportion of it will sow an acre.*

5629. *The whin, furze, or gorze (Ajonc, Jonc marin, Genét épineux, Fr.; Ulex europæa L., fig. 780.)*, is

780



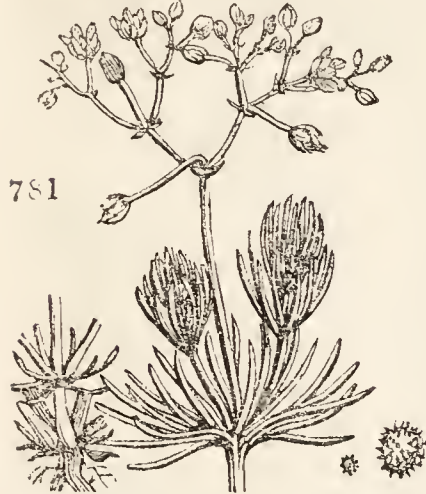
a well known shrub, found wild on dry light soils, and in rather hilly situations, in the warmer and more temperate parts of Europe; but not in Sweden, or in Russia or Poland, north of Cracow and Casan. It has been known as a nourishing food for cattle from a very early period, and has been sown in some parts of England for that purpose and for fuel. *Dr. Anderson* knows few plants that deserve the attention of the farmer more than the whin. Horses are peculiarly fond of it; so much so, that some persons think they may be made to perform hard work upon it, without any feeding of grain: but he thinks it tends more to fatten a horse than to fit him for hard labour, and that therefore some grain should be given with it where the work is severe. Cattle, he says, eat it perfectly well when thoroughly bruised, and grow as fat upon it as upon turnips; but unless it be very well bruised for them, they will not eat it freely, and the farmer will be disappointed in his expectations. It has lately been found excellent food for horses in the Highlands of Scotland. (*High. Soc. Trans.* vol. v.) Cows fed upon it yield nearly as much milk as while upon grass, and it is free from any bad taste. The best winter-made butter he ever saw was obtained from the milk of a cow fed upon this plant. This food should be made use of soon after being prepared. Two bushels, with a proper allowance of hay, have been found to be sufficient for a day for three horses performing the same labour as with corn. It also seemed useful to horses labouring under broken wind and grease.

Poor hungry gravelly soils, which would not have let for five shillings an acre, have been rendered worth twenty shillings by sowing them with furze-seed, in places where fuel has been scarce; the furze being frequently used for heating ovens, burning lime and bricks, and also for drying malt: but it is not worth cultivating in countries where fuel of any kind is cheap, or upon such lands as will produce good grass, corn, or other crops employed as the food of animals.

5630. *The culture of the whin is thus given by the same author:—* A field of a good dry loamy land, being well prepared, he sowed, along with a crop of barley, the seeds of the whin in the same way as clover is usually sown, allowing at the rate of from fifteen to thirty pounds of seed to the acre. The seeds, if harrowed in and rolled with the barley, quickly spring up, and advance under the shelter of the barley during the summer, and keep alive during the winter. Next season, if the field has not a great tendency to run to grass so as to choke them, they advance rapidly after midsummer, so as to produce a pretty full crop before winter. This you may begin to cut with a scythe immediately after your clover fails, and continue to cut it as wanted during the whole of the winter; but it is supposed that, after the month of February, the taste of this plant alters, as it is in general believed that after that time horses and cattle are no longer fond of it. He, however, observes, that never having had a sufficiency of whins to serve longer than towards the middle of February or beginning of March, he cannot assert the fact from his own experience. He has frequently seen horses beating the whins with their hoofs, so as to bruise the prickles, and then eating them, even in the months of April and May; and he says, that sheep which have been used to this food certainly pick off the blossoms and the young pods at that season, and probably the prickles also; so that it is possible the opinion may only be a vulgar error. This is, he thinks, the best way of rearing whins as a crop for a winter food for cattle or horses. But for sheep, who take to this food very kindly when they have once been accustomed to it, less nicety is required; for if the seeds be simply sown broad-cast, very thin (about a pound of seed per acre) upon the poorest soils, after they come up the sheep of themselves will crop the plants, and soon bring them into round close bushes, as this animal nibbles off the prickles one by one very quickly, so as not to be hurt by them. Sheep, however, who have not been used to this mode of browsing do not know how to proceed, and often will not taste them; but a few that have been used to the food will, he observes, soon teach all the rest how to use it.

5631. *Another very economical way of rearing whins*, but which he has seen practised rather than experienced himself, is this:— Let a farm be enclosed by means of a ditch all round, with a bank thrown up on one side, and if stones can be had, let the face of that bank be lined with the stones, from bottom to near the top, this lining to slope backwards with an angle of about sixty or seventy degrees from the horizon. Any kind of stones, even round ones gathered from the land, will answer the purpose very well; upon the top of the bank sow whin-seeds pretty thick, and throw a few of them along the face of the bank. Young plants will quickly appear. Let them grow for two years, and then cut them down by means of a hedge-bill, sloping down by the face of the bank. This mode of cutting is very easy, and as the seeds soon insinuate themselves among the crannies of the stones, the whole face of the bank becomes a close hedge, whose shoots spring up with great luxuriance. If another ditch be made on the other side of the bank, and if this be managed in the same way, and the hedge cut down only once every second year (and in this way it affords very good food for beasts), the inside and outside being cut down alternately, the fence will at all times continue good, as the hedge at the top will at all times be complete. This mode of rearing whins is, he remarks, both convenient and economical. But where stones cannot be obtained for making the facing, the bank very soon moulders down, and becomes unfit for the purposes of a fence. Circumstances have prevented him from ascertaining what is the weight of the crop that may be thus attained, but he thinks he may safely venture to say, that it is at least equal to that of a crop of green clover; and if it be considered, that this affords a green succulent food during winter, on which cattle can be fattened as well as on cut grass in summer, it will, he thinks, be admitted, that it must be accounted even a more valuable crop than clover. After being cut, he also remarks, that it springs up the following season with greater vigour than before, and in this situation acquires a degree of health and succulence very different from what it is ever observed to possess in its natural state. He has seen shoots of one season near four feet in length. The prickles too are so soft, and the stems so tender, that very little bruising is necessary; indeed horses, that have been accustomed to this food, would eat it without any bruising at all; but horned cattle, whose mouths seem to be more tender, always require it to be well bruised. How long crops of this sort may continue to be annually cut over without wearing out, he cannot say, but he believes a long while in favourable circumstances. One thing, however, it is necessary to attend to in

order to guard against its being destroyed: as, during the beginning of the season, nature seems to be solely employed about the great work of fructification, and it is not till near Midsummer that the whin begins to push forth its wood-bearing branches, which advance with great luxuriance during the latter part of the season only, it may happen, that if care be not taken to have the grass that springs up on the field, before the whin begins to send out its shoots, eaten close down, that grass will acquire such a luxuriance before the young branches of the whin begin to advance, as to overtop them, and choke them entirely. Whoever, therefore, has a field under this particular crop, must be careful to advert to this circumstance, or, if the field be in good heart, he will infallibly lose it. The field therefore should be kept as



781

a pasture, bare as possible during the beginning of the season, and the cattle should only be taken from it when the shoots of the whin begin to advance with vigour. Under this management, he presumes, it may be kept for many years, and yield full crops; but, unless the mowers be particularly attentive at the beginning, to cut it as low as possible, it will very soon become impossible to cut the field with a scythe, as the stumps will acquire so much strength as to break the scythe when it happens to touch them.

5632. *The spurry* (*Spergule*, Fr.; *Spérgula arvensis* L., fig. 781.) is a diminutive annual weed, on dry sandy corn-lands, in most parts of Europe. In Germany and the Netherlands, it is sown on the corn stubbles, and in the intervals of time that occur between some crops is fed with sheep. It may be sown and reaped in eight weeks, either in autumn or spring. It is said to enrich the milk of cows, so as to make it afford excellent butter; and the mutton fed on it is preferable to that fed on turnips. Hens eat spurry greedily, and it is supposed to make them lay a great number of eggs. Whether in hay, or cut green, or in pasture, Von Thaer observes, it is the most nourishing, in proportion to its bulk, of all forage, and gives the best flavoured milk and butter. It has been recommended to be cultivated in England; but it ever pay the expense of seed and labour in this country, even on the poorest soil, or at all events, as Professor Martyn observes, we have many better plants for such soils.

is not likely that such a plant can

5633. *The common broom* (*Genêt commun*, Fr.; *Spártium scoparium* L., fig. 782.) is cultivated in the



782

southern parts of France, on the poorer sorts of soil, in the same way as hemp, for the purpose of stripping the bark from it, and converting it into a kind of thread. It is likewise cultivated in these places as a winter-food for sheep, and it is said they eat it with great avidity, preferring it to many other plants. It is, however, liable to produce diseases of the urinary passages, by its diuretic qualities. It has been recommended by Young to be cultivated in England as food for sheep and horses, who are said to eat it after they get accustomed to it; also for thatch, ropes, besoms, food for bees, fuel, and burning on the spot to improve the soil. Its culture is the same as that of the whin; but very peculiar, indeed, must be that situation, where its culture is attempted for any of the above purposes. It is a useful protection of game in plantations, from which source abundance may be had for besoms. The Spanish broom (*S. júnceum* L., fig. 783.) might



783

be grown perhaps still more advantageously than the common species.

5634. *The parsley* (*Persil commun*, Fr.; *Apium Petroselinum* L., fig. 784.) is a well known biennial



784

with a large sweet tap-root. It is a native of Sicily, but endures the British winter like a native plant. It is sown along with clover and grass seeds in some places, and especially in Lincolnshire, as a preventive of the rot in sheep. Fleet, of Hampshire, famous for curing the rot in sheep, cultivates it largely with success: he sows half a bushel to the acre, with a bushel of rye-grass with spring corn; and he finds that it lasts in the ground till it is permitted to seed. He feeds it constantly; it being excellent for sheep, and, when suffered to get a-head, wonderfully fed upon by pigs in the autumn. After September, it will not, he says, run to seed. When it was ploughed up he obtained good oats. The land was poor, and in the next round of the course, the clover was much the better for the parsley having been sown or the clover omitted; for in a field half parsley, half clover, when the clover came again to be sown, it was excellent on the parsley half, but bad on the clover part. In laying down land to grass, Hoyte, in the fourth volume of *Communications to the Board of Agriculture*, advises the sowing with twelve pounds of white clover, two pounds of red clover, two pecks of rye-grass, and two pounds of parsley to the acre, as the parsley stands two years, and by its diuretic qualities prevents the sheep from dying of the red-water, which too luxuriant clovers are apt to produce. In Scotland, also, it has been sown with success, and greedily eaten by horses, cows, and hogs. The seed requires a longer period to germinate than that of any other agricultural plant, and might probably be advantageously prepared by steeping and turning. It must be fresh, as two-year-old seed will not grow. It is easily procured by the pound or bushel, from the seedsman,

and as easily raised by letting a few drills in a garden shoot into flower-stems.

5635. *The Spiræa Ulmária* L.; queen of the meadows, *Reine des Prés* Fr.; the *Scabiòsa arvensis*; the *Hé-speris matronális*; the *Centaurèa Jácea*, are sown in France along with the perennial grasses, and their seeds may be had in the French seed shops, but they cannot be recommended in soils and climates where any of the clovers or true grasses will thrive so as to form an abundant herbage.

5636. *The wallflower* (*Cheiránthus Cheiri* L.) is a well known garden flower, and at the same time a native, and very hardy on dry soils. Like the parsley it is an antiseptic, and has been recommended to be cultivated for the same purposes, and in the same manner.

5637. *The bird's foot trefoil* (*Lotier*, Fr. ; *Lötus corniculätus* L., fig. 785.) has been tried as a substitute



for white clover on moist lands, and seems to succeed very well, but to have no particular advantages over the clover. *Lötus major* has been found by Mr. Sinclair to afford triple the weight of green food and hay afforded by *Lötus corniculätus*; its nutritive powers compared with that plant are as nine to eight; but on the whole, he says, both species are greatly inferior to white clover. (*Gram. Wob.* 2d ed. p. 311.) *Lötus villosus* and *tetragonolobus*, the *Lotier cultivé* of the French (fig. 786.), are a good deal cultivated in France on light soils. The latter is an annual sown in our gardens.



5638. *The fenugreek* (*Sennegrain*, Fr. ; *Trigonëlla Fœnum-græcum* L., fig. 787.), Greek hay, was formerly cultivated in Italy, and still holds a prominent place in the agriculture of Egypt. In France it is cultivated to a limited extent near Paris for its seeds, which are used in medicine.

5639. *The serradilla* (*Ornithopus sativus* of Persoon's *Synopsis*) was introduced for purposes of field culture about the year 1818, from Portugal, and sown upon the light barren downs of Thetford in Norfolk, and Amptill and other places in Bedfordshire. It is said to have produced abundant crops, two

feet high, of excellent fodder, where scarcely any thing else would grow. Its culture, however, is no longer in use in England, and it does not enter into the agriculture of France.

5640. *Galëga officinälis*; *Láthyus Cícera*, *latifolius*, *sylvestris*, *pratënsis*, *hirsütus*, *heterophýllus*, and *tingitänus*; *Ervum Ervilia*, and *monänthos*; *Lötus villosus*, and *tetragonolobus*; *Vicia angustifolia*, *Crácca*, *Pseüdo-Crácca*, *biënnis*, *sëpium*, and *lütea*; *Anthýllis vulneräria*; and *Astrágalus glyciphyllus* and *galegifórmis*, are all used as herbage plants in the agriculture of France.

5641. *The oriental bunias* (*Bünias orientälis* L., fig. 788. a) is a perennial plant, with leaves, branches, and its general habit of herbage, not

unlike the wild chiccory. It is a native of the Levant, and has been cultivated by way of experiment in the grass garden at Woburn. It is less productive than chiccory, bears mowing well, and affords the same nutriment, in proportion to its bulk, as red clover. (*Agricultural Chem.* p. 374.)

5642. *The yarrow* (*Millefeuille*, Fr. ; *Achillëa Millefolium* L. fig. 788. b), the *common and alpine ladies' mantle* (*Alchemilla vulgaris* and *alpina* L.), and others, have been tried among perennial grasses, sown in parks, with a view to give flavour to milk, butter, mutton, and venison. Sinclair considers yarrow as an essential ingredient of the most fattening and healthy pastures. In all the pastures most celebrated for fattening or dairy produce, which he examined in Devonshire, Lincolnshire, and in the vale of Aylesbury, yarrow was present more or less in every part of the surface. (*Hort. Gram. Wob.* 2d edit. p. 412.)



CHAP. VI.

Cultivated Grasses.

5643. *The forage or hay and pasture grasses*, of which we are now about to treat, are found clothing the surface of the earth in every zone, attaining generally a greater height, with less closeness at the root in the warm climates; and producing a low, close, thick, dark green nutritive herbage, in the cooler latitudes. The best grass pastures, those which are most productive and nutritive, are such as are found in countries that have least cold in winter, and no excess of heat in summer. Ireland, Britain, and part of Holland and Denmark, may equal or surpass any countries of the world in this respect; but in every zone where there are high mountains, there are certain positions between the base and summit, where, from the equability of the temperature, turf may be found equal to that in marine islands. It is a singular circumstance with regard to grasses,

that in the greater part of North America, the sorts that grow naturally on the plains are almost all annuals, and consequently with the first frost they die, and the ground remains naked till a fresh crop rises from the self-sown seeds next spring. Nearly the same thing may be said of Poland and Russia, with the exception of the banks of rivers and the mountains.

5644. *The universal presence of the forage grasses*, and the rapidity with which all soils become covered with them when left uncultivated, are the obvious reasons why their systematic selection and culture are but of recent date. Though the Romans cultivated clovers, and were careful of their meadows, it does not appear that the seeds of the proper grasses were collected and sown by them. None of the agricultural writers, from Peter of Bologna to Parkinson in 1640, say a word about sowing grasses, though they all mention clover and lucern. This branch of culture appears to have originated in England about the middle of the seventeenth century, and the grass made choice of was the rye-grass. The first mention made of it for cultivation is in Dr. Plot's *Oxfordshire*, printed in 1677. "They have lately sown," says he, "ray-grass, or the *Græmen loliæcum*, by which they improve any cold, sour, clay-weeping ground, for which it is best, but good also for drier upland grounds, especially light stony or sandy land, which is unfit for saintfoin. It was first sown in the Chiltern parts of Oxfordshire, and since brought nearer Oxford by one Eustace, an ingenious husbandman of Islip, who, though at first laughed at, has since been followed even by those very persons that scorned his experiment." The first grass tried after rye-grass appears to have been the *Phlèum pratense*, by Rocque of Walham Green, about 1760. Soon afterwards the seed of cock's-foot grass was introduced from Virginia, under the name of orchard-grass, by the Society of Arts. (*Ann. Reg.* 1765. 141.); fox-tail was tried at a later period, on the suggestions of Stillingfleet and Curtis.

5645. *Stillingfleet*, about 1759, drew the attention of the reading agriculturist to the selection of different species of grasses; as did Dr. Anderson about the same time, and Swayne (*Gràmina Pâscua*) and Curtis (*Observations on British Grasses*) soon afterwards. The origin of this attention to grasses and native plants may be traced to the practice of forming local floras by botanists, and especially to the *Flora Suécica* of Linnæus; and the *British Floras* of Hudson, Withering, Lightfoot, Smith, &c. in which the medical and economical properties of the plants were mentioned; and, in imitation of Linnæus, particular notice taken of the animals which fed upon them.

5646. *John Duke of Bedford* made the latest and most laborious efforts towards attaining a knowledge of the comparative value of all the British and some foreign grasses worth cultivating. The result is given in an appendix to Sir H. Davy's *Agricultural Chemistry*, and more at large in Sinclair's *Hortus Gramineus Woburnensis*, 8vo. 2d edit. 1825, a work which may truly be said to form an epoch in this department of agriculture, and which will probably long continue to be the ground-work of all that shall continue to be done in this branch of the subject.

5647. *With respect to the general culture of grasses*, though no department of agriculture is more simple in the execution, yet, from their nature, considerable judgment is required in the design. Though grasses abound in every soil and situation, yet, all the species do not abound in every soil and situation indifferently. On the contrary, no class of perfect plants is so absolute and unalterable in its choice in this respect. The creeping-rooted and stoloniferous grasses will grow readily on most soils; but the fibrous-rooted species, and especially the more delicate upland grasses, require particular attention as to the soil in which they are sown; for in many soils they will either not come up at all, or die away in a few years, and give way to the grasses which would naturally spring up in such a soil when left to a state of nature. Hence, in sowing down lands for permanent pasture, it is a good method to make choice of those grasses which thrive best in adjoining and similarly-circumstanced pastures for a part of the seed; and to mix with these what are considered the very best kinds.

5648. *The most important feature* in the culture of pasture grasses is mixture of sorts. The husbandman, observes one of the most scientific agriculturists in Scotland, who clothes his fields only with rye-grass and clover, employs a limited machinery, the former being unproductive in summer, the latter moderately so in spring; but when he, for this purpose, uses a variety of plants differing in their habits of growth, and periods of luxuriance, a numerous and powerful machinery is kept successively in full operation. (*Quar. Jour. Ag.* vol. ii. p. 247.)

5649. *The effect of a mixture of grasses* may be accounted for from some species putting forth their foliage, and reaching a maximum of produce at different periods from other kinds. From some being gregarious or social, and others solitary and never producing a close turf; by sowing seeds of several species together, which are dissimilar in their habits of growth, and arrive at a maximum of produce at different periods of summer and autumn, there is secured throughout the season a succession of fresh herbage, rendered, by the erect and creeping foliage of the different species, so dense and abundant as greatly to surpass in quantity that obtained from the cultivation of two or three kinds only. (*Ibid.* p. 246.)

5650. *New and excellent varieties* of many of the grasses, especially those used or fit to be used in the convertible husbandry, might no doubt be obtained by selection and cross-breeding, and it is much to be wished that this were attempted by cultivators.

5651. *The grasses to be here treated of* may be classed as tall sorts, or those best fitted for hay; and dwarf grasses, or those fit only for pasturage: those experimented on at Woburn will next be noticed.

SECT. I. *Tall-growing or Hay Grasses.*

5652. *The hay grasses* for the purposes of agriculture may be advantageously divided into those of temporary, and those of permanent duration.

SUBSECT. 1. *Tall or Hay Grasses of temporary Duration.*

5653. *The most valuable of this division* are the biennial, or, as it is commonly but erroneously called, the annual, perennial, and subperennial rye-grass (*fig.* 789. a), the



cock's-foot grass (*b*), and woolly soft grass (*c*). Where a crop of hay is desired within the year, it is necessary to resort to such grasses as are annuals in the strict sense of the word; and none can be better for this purpose than the common oat (*Avèna sativa*), cut and made into hay when it comes into flower. Next in order may be mentioned the other cereal grasses and the annual varieties of *Bròmus*: the latter, however, are very coarse grasses, though prolific in culm.

5654. *The biennial rye-grass* (*Lòlium perénne* var. *biénne* L.) is well known, as being universally sown, either with or without clover, among corn crops, with a view to one crop of hay in the succeeding season.

It attains a greater height, and produces a longer broader spike of flowers, than the perennial rye-grass, and the produce in hay is considered greater than that of any other annual grass, equally palatable to cattle. It prefers a rich loamy soil, but will grow on any surface whatever, not rock or undecayed bog.

5655. *The perennial rye-grass* (*Lòlium perénne* L. *Ivraie vivace*, Fr.; *Daurende Lolche*, Ger.; and *Loglio vivace*, Ital.) differs from the other in being of somewhat smaller growth, and in abiding for several years, according to the variety and the soil and culture.

5656. *Many consider this grass coarse, benty, and very exhausting to the soil*; but, after all the experiments that have been made on the other grasses, none have been found to equal it for a course of mowing and pasturing for two, three, or seven years. It is sown in Italy, and especially in Lombardy, and also in France and Germany, along with clover, for the same purposes as in this country; and, as Von Thaer has remarked, though some have tried other species, both in these countries and in England, they have in the end returned to rye-grass. When intended as a pasture-grass, if stocked hard, and when for hay, if mown early, the objections to it are removed. (*Code of Agriculture*.) G. Sinclair says the circumstance of its producing abundance of seed, which is easily collected, and vegetates freely on any soil, its early perfection and abundant herbage the first year, which is much relished by cattle, are the merits which have upheld it to the present day, and will probably for some time to come continue it a favourite grass among farmers. But the lattermath is inconsiderable, the plant impoverishes the soil in a high degree if not cut before the seed ripens. When this is neglected, the field after midsummer exhibits only a brown surface of withered straws. Let the produce and nutritive powers of rye-grass be compared with those of the cock's-foot grass, and it will be found inferior nearly in the proportion of 5 to 18; to meadow fox-tail of 5 to 12; and to meadow fescue of 5 to 17. (*Hort. Gram. Wob.* 2d edit. 215. and see § 5662.) In a subsequent page he observes, "The new varieties, however, of this species of grass, which have been discovered of late years, remove in a considerable degree the serious objections which applied to the common rye-grass." (*Ib.* 412.) The varieties alluded to are all perennial, and as under:

Slender rye-grass, common in dry impoverished pasture land.

Compound or broad spikèd rye-grass, found in rich soils, long under grass, and chiefly in beaten parts, as cart-ways, &c. It has a short broad spike, crowded with spikelets at the top.

Pacey's rye-grass, found in rich meadow lands, and introduced by Pacey, a cultivator in the uplands of Staffordshire; spike nearly upright, spikelets shorter than in the compound rye-grass, the stem furnished with long leaves, and the root leaves large and numerous. Sinclair considers this the most valuable variety of the rye-grass.

Whitworth's rye-grass, introduced by G. Whitworth, Esq.,

of Acre House, Lincolnshire, an eminent cultivator of the pasture grasses, who, in 1823, had 60 varieties of *Lòlium perénne* under experiment.

Stickney's rye-grass, introduced by Stickney of Holderness.

Russell's rye-grass, first cultivated by the late B. Holditch, Esq., editor of *The Farmer's Journal*, from seed obtained of a plant in a rich fen pasture, pointed out to Holditch by the Duke of Bedford.

Church bennet, or Church bent-grass, an excellent variety of rye-grass, cultivated in some parts of Berkshire.

All the above, except the first two, are excellent varieties. Pacey's and Russell's are considered the best.

5657. *The proportional value* which the grass at the time of flowering bears to the grass at the time the seed is ripe, is as 10 to 11. The proportional value which the grass of the lattermath bears to the grass at the time of flowering, is as 4 to 10; and to grass at the time the seed is ripe, as 4 to 11.

5658. *The seed of perennial rye-grass* is not to be distinguished from that of the annual variety. It may be collected by hand, in most parts of Britain, from old pastures, and a considerable quantity is annually so procured in Kent and Sussex. It is also grown purposely for seed in England and Scotland. Formerly it was the practice for farmers to collect the seed which dropped from the hay used by their horses; but rye-grass, grown for hay, is now cut, by all judicious farmers, when it is just coming into flower; and therefore to collect the glumes or empty husks can be of no use as seed. It has also been a common practice, in regard to rye-grass, to let the mixed crop of that and clover stand till the seeds of the former have attained a considerable degree of ripeness, when it is cut down and made into hay, in the usual manner; and the seeds of the rye-grass are separated by the use of the flail, commonly before the hay is put into the field-ricks. Sometimes, when but a small quantity is wanted, the hay is merely shaken well upon a cloth, when it is building in the stack-yard; or afterwards in the stable-loft, before it is put into the horse's racks. But in all of these methods, in order to obtain good seed, the clover must remain uncut beyond the proper season; and it is thus materially injured in quality, while the value of the rye-grass seed, in such a crop, is merely a secondary consideration.

5659. *When seed is the principal object* of the culture of rye-grass, it ought not to be mixed with clover at all, though it may be sown along with any of the kinds of corn, and treated the year after in every respect as a crop of corn; bound up in sheaves, built in stacks, threshed with the flail, and dressed by the winnowing-machine in the same manner.

5660. *The difficulty of distinguishing between the annual and perennial varieties of rye-grass* has led to the practice, in some places, of cutting or pasturing the first year's crop, and taking a crop for seed the second year. If the growth of the rye-grass plants be close and vigorous the second year, there is reason to be satisfied that the seed is of the perennial variety; and though red clover was sown with the rye-grass, a great part of it disappears by that time, and forms but a small portion of the second year's cutting. (*Sup. Encyc. Brit.* art. Agr.)

5661. *The cock's-foot grass* (*Dáctylis glomeràta L., fig. 788. b*) is an imperfect perennial, and grows naturally on dry sandy soils. This grass may be known by its coarse appearance, both of the leaf and spike, and also by its whitish green hue.

5662. *One writer says*, he has cultivated it largely, and to his satisfaction, on wet loams on a clay marl bottom, upon which the finer grasses are apt to give way in a few years to the indigenous produce. If suffered to rise high, it is very coarse; but, fed close, is a very valuable sheep pasture. He has sown two bushels an acre, and 10lbs. common red clover; and when the clover wears out, the grass fills the lands and abides well in it. It grows well in winter. It has been found highly useful as an early sheep feed. It is early, hardy, and productive, but is a coarser plant than rye-grass, and requires even greater attention in regard to being cut soon, or fed close. It does best by itself, and the time of its ripening being different from that of clover, it does not suit well to be mixed with that plant. The pasturage it affords is luxuriant, and particularly agreeable to sheep. It is cultivated to a great extent, and with astonishing success, at Holkham. The quantity of sheep kept upon it, summer and winter, is quite surprising; and the land becomes renovated by lying two or three years under this grass, and enriched by the manure derived from the sheep. A field, in the park at Woburn, was laid down in two equal parts, one part with rye-grass and white clover, and the other part with cock's-foot and red clover: from the spring till midsummer, the sheep kept almost constantly on the rye-grass; but after that time they left it, and adhered with equal constancy to the cock's-foot during the remainder of the season. In *The Code of Agriculture* (p. 497. 3d edit.) it is stated, that Sinclair of Woburn considers "no grass so well suited for all purposes as cock's-foot;" and in the second edition of the *Hortus Gramineus Woburnensis*, it is observed, that if one species only is thought preferable to another in the alternate husbandry, that species is the *Dáctylis glomeràta*, from its more numerous merits. But a certain supply of the most nutritious herbage throughout the season will be in vain looked for from any one species of grass, and can only be found where nature has provided it in a combination of many. None appear better fitted for mixing with *Dáctylis* than *Festùca duriúscula* and *praténsis*, *Pòa triviàlis*, *Hólcus avenàceus*, *Phlèum pratense*, *Lólium perénne*, and white clover. "A combination thus formed, of three parts cock's-foot, and one part of these species just mentioned, will secure the most productive and nutritive pasture in alternation with grain crops, on soils of the best quality; and even on soils of an inferior nature, under the circumstances of unfavourable seasons, will afford nutritive herbage, when otherwise the land would have been comparatively devoid of it, if one species of grass only had been employed." (*Hort. Gram. Wob. 2d edit. 414.*)

5663. *The proportional value* which the grass at the time of flowering bears to the grass at the time the seed is ripe, is as 5 to 7 nearly. The proportional value which the grass of the lattermath bears to the grass at the time of flowering, is as 6 to 10; and to the grass at the time the seed is ripe, as 6 to 14. Sixty-four drachms of the straws at the time of flowering afford of nutritive matter 1·2 dr. The leaves or lattermath, and the straws simply, are therefore of equal proportional value; a circumstance which will point out this grass to be more valuable for permanent pasture than for hay. The above details prove, that a loss of nearly one third of the value of the crop is sustained, if left to the period when the seed is ripe, though the proportional value of the grass at that time is greater, *i. e.* as 7 to 5. The produce does not increase if the grass is left growing after the period of flowering, but uniformly decreases; and the loss of lattermath (from the rapid growth of the foliage after the grass is cropped) is very considerable. These circumstances point out the necessity of keeping this grass closely cropped, either with the scythe or cattle, to reap the full benefit of its merits.

5664. *The woolly soft grass* (*Hólcus lanàtus L., fig. 580. c*) is an imperfect perennial, and rather late flowering grass, of a short unsubstantial appearance, and found chiefly in poor dry soils. It is, however, a very common grass, and grows on all soils, from the richest to the poorest. It affords abundance of seed, which is light, and easily dispersed by the wind.

5665. *It was cultivated at Woburn on a strong clayey loam*, and the proportional value which the grass at the time the seed is ripe, bears to the grass at the time of flowering, is as 11 to 12. Young of Essex observes of this grass, that it flourishes well on any moist soil, and should be sown chiefly with a view to sheep, for it is not so good for other stock: many acres of it have been cultivated on his farm for sheep, and it has answered well when kept close fed. Marshal, in his *Midland Counties*, mentions it as a good grass for cows and other cattle, but bad for horses. In his *Rural Economy of Yorkshire*, he, however, condemns it altogether.

5666. *According to Sinclair, of Woburn*, "it appears to be generally disliked by all sorts of cattle. The produce is not so great as a view of it in the fields would indicate; but being left almost entirely untouched by cattle, it appears the most productive part of the herbage. The hay which is made of it, from the number of downy hairs which cover the surface of the leaves, is soft and spongy, and disliked by cattle in general." The Woburn experiments lead to the conclusion that the *Hólcus móllis* is a better hay plant than the species here noticed; but as that is a more durable perennial it is less fitted for the temporary purposes of this section.

5667. *The culture of these grasses* may be considered the same as that of rye-grass, which was discussed when treating of clover and rye-grass. (5540.) The seeds of all of them are sold by the principal seedsmen, or may be gathered on grass-fields, or hedge wastes, by women or children at an easy rate.

SUBJECT. 2. *Tall or Hay Grasses of permanent Duration.*

5668. *No permanent grass* has been found equal to the rye-grass for the purposes of convertible husbandry, but others have been selected which are considered superior for hay meadows. The principal of these are the fescue, fox-tail, and meadow-grass. Agriculturists, indeed, are not all agreed on the comparative merits of these grasses with rye-grass; but there are none who do not consider it advisable to introduce a portion of each, or most of these species along with rye-grass, in laying down lands to permanent pasture. The nutritive products of these grasses, of perennial rye-grass, and of that singular grass florin, are thus given by Sir H. Davy: —

Systematic Name.	English Name.	In 100 Parts.				
		Whole quantity of soluble or nutritive matter.	Mucilage or starch.	Saccharine matter or sugar.	Gluten or albumen.	Extract or matter rendered insoluble during evaporation.
<i>Festuca loliàcea</i> (fig. 790. c)	Spiked fescue grass	19	15	2	—	2
<i>Hólcus odoràtus</i>	Sweet-scented soft grass	82	72	4	—	6
<i>Anthoxánthum vérnium</i>	Sweet-scented vernal grass	50	43	4	—	3
<i>Alopecùrus praténsis</i> (d)	Meadow fox-tail grass	33	24	3	—	6
<i>Pòa fértilis</i> (e)	Fertile meadow grass	78	65	6	—	7
<i>triviàlis</i> (f)	Roughish meadow grass	39	29	5	—	6
<i>Cynosùrus cristàtus</i>	Crested dog's-tail grass	35	28	3	—	4
<i>Lòlium perénne</i>	Perennial rye-grass	39	26	4	—	5
<i>Agròstis stolonífera</i>	Fiorin	54	46	5	1	2
	Fiorin cut in winter	76	64	8	1	3



5669. Of the fescue grass there are three species in the highest estimation as meadow hay grasses, viz. the meadow, tall, and spiked fescue. (fig. 790. a, b, c.)

5670. The *F. praténsis* (a), or the meadow or fertile fescue grass, is found in most rich meadows and pastures in England, and is highly grateful to every description of stock. It is more in demand for laying down meadows than any other species except the rye-grass. By the Woburn experiments, the value of this grass at the time the seed is ripe, is to that of the grass at the time of flowering, as 6 to 18. The loss which is sustained by leaving the crop of this grass till the seed be ripe is very great. That it loses more of its weight in drying at this stage of growth, than at the time of flowering, perfectly agrees with the deficiency of nutritive matter in the seed crop, in proportion to that in the flowering crop: the straws being succulent in the former, they constitute the greatest part of the weight; but in the latter they are comparatively withered and dry, consequently the leaves constitute the greatest part of the weight. It may be observed here, that there is a great difference between straws or leaves that have been dried after they were cut in a succulent state, and those which are dried by nature while growing. The former retain all their nutritive powers; but the latter, if completely dry, very little, if any.

5671. The tall or infertile fescue grass (*Festuca elàtior* E. B. b) is closely allied to the *Festuca praténsis*, from which it differs in little, except that it is larger in every respect. The produce is nearly three times that of the *F. praténsis*, and the nutritive powers of the grass are superior, in direct proportion, as 6 to 8. The proportional value which the grass at the time the seed is ripe, bears to the grass at the time of flowering, is as 12 to 20. The proportional value which the grass of the lattermath bears to that of the crop, is as 16 to 20; and to the grass at the time the seed is ripe, as 12 to 16 inverse. Curtis observes, that as the seeds of this plant, when cultivated, are not fertile, it can only be introduced by parting its roots and planting them out; in this there would, says he, be no great difficulty, provided it were likely to answer the expense, which he is strongly of opinion it would in certain cases; indeed he has often thought that meadows would be best formed by planting out the roots of grasses, and other plants, in a regular manner; and that, however singular such a practice may appear at present, it will probably be adopted at some future period: this great advantage would, he says, attend it, noxious weeds might be more easily kept down, until the grasses and other plants had established themselves in the soil.

5672. The spiked fescue grass, or darnel fescue grass (*Festuca loliàcea* L. c), resembles the rye-grass in appearance, and the tall fescue grass in the infertility of its seeds. It is considered superior to rye-grass either for hay or permanent pasture, and improves in proportion to its age, which is the reverse of what takes place with the rye-grass.

5673. The meadow fox-tail grass (*Alopecùrus praténsis*, d) is found in most meadows; and when the soil is neither very moist nor very dry, but in good heart, it is very productive. It also does well on water meadows. Sheep and horses seem to have a greater relish than oxen for this grass.

5674. In the Woburn experiments, it was tried both on a sandy loam and a clayey loam, and the result gave nearly three fourths of produce greater from a clayey loam than from a sandy soil, and the grass from the latter is comparatively of less value, in proportion as 4 to 6. The straws produced by the sandy soil are deficient in number, and in every respect less than those from the clayey loam; which will account for the unequal quantities of the nutritive matter afforded by them; but the proportional value in which the grass of the lattermath exceeds that of the crop at the time of flowering, is as 4 to 3: a difference which appears extraordinary, when the quantity of flower-stalks which are in the grass at the time of flowering is considered. In the *Anthoxánthum odoràtum* the proportional difference between the grass of these crops is still greater, nearly as 4 to 9; in the *Pòa praténsis* they are equal; but in all the

latter flowering grasses experimented upon, the flowering straws of which resemble those of the *Alopecurus pratensis*, or *Anthoxanthum odoratum*, the greater proportional value is always, on the contrary, found in the grass of the flowering crop. Whatever the cause may be, it is evident that the loss sustained by taking the crops of these grasses at the time of flowering is considerable. The proportional value which the grass at the time of flowering bears to that at the time the seed is ripe, is as 6 to 9. The proportional value which the whole of the lattermath crop bears to that at the time the seed is ripe, is as 5 to 9; and to that at the time of flowering, proportionably as 13 to 24. Next to the fescue, this grass is in the greatest reputation for laying down mowing grounds; but it is unfortunately subject to the rust in some situations.

5675. *Of the meadow grass* there are two species in esteem as hay plants, the smooth-stalked, and roughish. These plants compose the greater part of the celebrated Orcheston meadows near Salisbury, and also of the meadows near Edinburgh.

5676. *The great or smooth stalked meadow grass*, the spear grass of America (*Poa pratensis*, e), is distinguished by its height, smooth stem, and creeping roots. According to Sole it is the best of all the grasses: its foliage begins to shoot and put on a fine verdure early in the spring, but not so soon as some other grasses. Every animal that eats grass is fond of it; while it makes the best hay, and affords the richest pasture. It abounds in the best meadows about Laycock and Chippenham, and has the valuable property of abiding in the same land, while most other grasses are continually changing. According to some it delights in rather a dry than a moist soil and situation, on which account it keeps its verdure better than most others in dry seasons; but it thrives most luxuriantly in rich meadows.

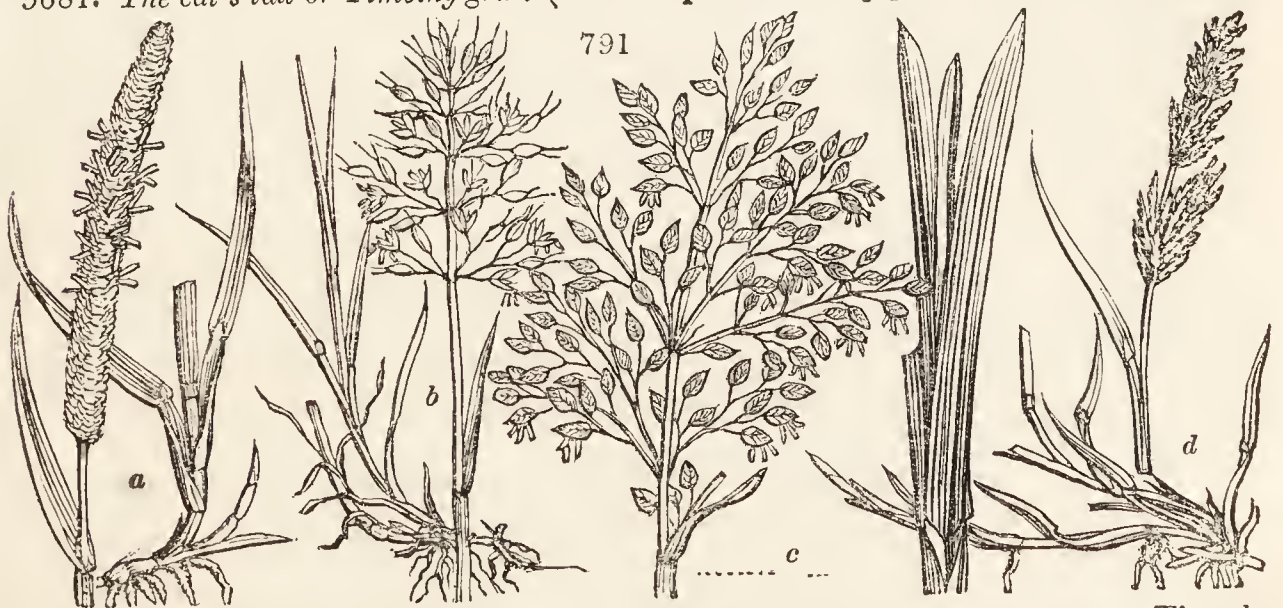
5677. *By the Woburn experiments*, the proportional value in which the grass of the lattermath exceeds that of the flowering crop, is as 6 to 7. The grass of the seed-crop, and that of the lattermath, are of equal value. This grass is, therefore, of least value at the time the seed is ripe; a loss of more than one fourth of the value of the whole crop is sustained if it is not cut till that period; the straws are then dry, and the root-leaves in a sickly decaying state: those of the lattermath, on the contrary, are luxuriant and healthy. This species sends forth flower-stalks but once in a season, and those being the most valuable part of the plant for the purpose of hay, it will, from this circumstance, and the superior value of the grass of the lattermath, compared to that of the seed-crop, appear well adapted for permanent pasture. It was of this grass that the American prize bonnet, in imitation of Leghorn, was manufactured by Miss Woodhouse.

5678. *The roughish meadow grass* (*Poa trivialis* L., f) delights in moist, rich, and sheltered situations, when it grows two feet high, and is very productive. By the Woburn experiments it appears that the proportional value in which the grass of the seed crop exceeds that at the time of flowering, is as 8 to 11. The proportional value by which the grass of the lattermath exceeds that of the flowering crop, is as 8 to 12; and that of the seed crop, as 11 to 12. Here, then, is a satisfactory proof of the superior value of the crop at the time the seed is ripe, and of the consequent loss sustained by taking it when in flower; the produce of each crop being nearly equal. The deficiency of hay in the flowering crop, in proportion to that of the seed crop, is very striking. Its superior produce, the highly nutritive powers which the grass seems to possess, and the season in which it arrives at perfection, are merits which distinguish it as one of the most valuable of those grasses which affect moist rich soils and sheltered situations: but on dry exposed situations, it is altogether inconsiderable; it yearly diminishes, and ultimately dies off, not unfrequently in the space of four or five years.

5679. *The above are six of the best British grasses*, for either dry or watered meadows. The seeds of the meadow fescue, fox-tail, and smooth and rough meadow grasses may be had from the seedsmen, and they are sown in various proportions with the clovers and rye-grass. The seeds of the two sorts of meadow grass are apt to stick together, and require to be well mixed with the others before being sown. The tall and spiked fescue grasses, having a number of barren flowers, are not prolific in seeds, and they are therefore seldom to be got at the seed-shops; though they may occasionally be had there gathered from plants in a wild state.

5680. *As hay grasses, adapted for particular soils and situations*, the cat's tail or Timothy, floating fescue, and fiorin grass, have been recommended; but it cannot be said that the opinions of cultivators are unanimous in their favour. Timothy has certainly been found to answer well on moist, peaty soils, and in several cases fiorin also.

5681. *The cat's tail or Timothy grass* (*Phlèum pratense* L., fig. 791. a) is a native plant,



and found both in dry and moist soils. It was first brought into notice by Timothy Hudson, about 1780, who introduced it from Carolina, where it was in great repute. On moist rich soils it is a prolific grass, but late; on dry soils it is good for little, and for cultivation in any way is disapproved of by Withering, Swaine, Curtis, and others, as having no properties in which it is not greatly surpassed by the *Alopecurus pratensis*.

5682. *The Woburn experiments*, however, present this grass as one of the most prolific for hay. Sixty-four drachms of the straws afforded seven drachms of nutritive matter. The nutritive powers of the

straws simply, therefore, exceed those of the leaves, in the proportion of 28 to 8; the nutritive powers of the grass, at the time of flowering, exceed those of the grass at the time the seed is ripe, in the proportion of 10 to 23; and the nutritive powers of the latter, those of the grass of the flowering crop, in the proportion of 8 to 10. The comparative merits of this grass will, from the above particulars, appear to be very great; to which may be added the abundance of fine foliage that it produces early in the spring. In this respect it is inferior to *Poa fertilis* and *Poa angustifolia* only. The value of the straws at the time the seed is ripe, exceeds that of the grass at the time of flowering, in the proportion of 28 to 10, a circumstance which raises it above many others; for from this property its valuable early foliage may be depastured to an advanced period of the season, without injury to the crop of hay, treatment which in grasses that send forth their flowering straws early in the season would cause a loss of nearly one half in the value of the crop, as clearly proved by former examples; and this property of the straws makes the plant peculiarly desirable for hay. In moist and peaty soils it has in various instances been found highly productive.

5683. *The floating fescue grass, Festuca fluitans (b)*, is found in rich swamps, especially in Cambridgeshire, where it is said to give the peculiar flavour to Cottenham and Cheddar cheese. It is also found in ditches and ponds in most parts of the country.

5684. *It is greedily devoured by every description of stock*, not excepting hogs and ducks, and geese eagerly devour the seeds, which are small, but very sweet and nourishing. They are collected in several parts of Germany and Poland, under the name of manna-seeds (*schwaden*), and are esteemed a delicacy in soups and gruels. When ground to meal, they make bread very little inferior to that from wheat. The bran is given to horses that have the worms; but they must be kept from water for some hours afterwards. Geese, and other water-fowl, are very fond of the seeds. So also are fish; trout, in particular, thrive in those rivers where this grass grows in plenty. It has been recommended to be sowed on meadows that admit flooding; but Curtis justly remarks, that the flote-fescue will not flourish except in land that is constantly under water, or converted into a bog or swamp.

5685. *The water meadow grass (Poa aquatica, c)* is found chiefly in marshes, but will grow on strong clays, and yield, as the Woburn experiments prove, a prodigious produce, flowering from June to September. It is one of the largest of our grasses.

5686. *In the fens of Cambridgeshire, Lincolnshire, &c.*, immense tracts, that used to be overflowed and to produce useless aquatic plants, and which, though drained by mills, still retain much moisture, are covered with this grass, which not only affords rich pasturage in summer, but forms the chief part of the winter fodder. It has a powerfully creeping root; and bears frequent mowing well. It is sometimes cut thrice in one season near the Thames. It grows not only in very moist ground, but in the water itself; and with cat's-tail, burr-reed, &c., soon fills up ditches, and occasions them to require frequent cleansing. In this respect it is a formidable plant, even in slow rivers. In the Isle of Ely they cleanse these by an instrument called a *bear*, which is an iron roller, with a number of pieces of iron, like small spades, fixed to it; this is drawn up and down the river by horses walking along the bank, and tears up the plants by the roots, which float, and are carried down the stream. The grass was, however, cultivated at Woburn on a strong tenacious clay, and yielded considerable produce.

5687. *The fiorin grass (Agróstis stolonifera, d)* is a very common grass both in wet and dry, rich and poor situations. Few plants appear to be more under the influence of local circumstances than this grass. On dry soils it is worth nothing; but on rich marl soils, and in a moist soil, if we may put confidence in the accounts given of its produce in Ireland, it is the most valuable of all herbage plants.

5688. *It was first brought into notice by Dr. Richardson in 1809*, and subsequently extolled, and its culture detailed in various pamphlets by the same gentleman. It appears to be exclusively adapted for moist peat soils or bogs. In *The Code of Agriculture* it is said, "On mere bogs, the fiorin yields a great weight of herbage, and is, perhaps, the most useful plant that bogs can produce." According to Sir H. Davy, the fiorin grass, to be in perfection, requires a moist climate or a wet soil; and it grows luxuriantly in cold clays unfitted for other grasses. In light sands, and in dry situations, its produce is much inferior as to quantity and quality. He saw four square yards of fiorin grass cut in the end of January, in a meadow exclusively appropriated to the cultivation of fiorin by the Countess of Hardwicke, the soil of which is a damp stiff clay. They afforded twenty-eight pounds of fodder, of which one thousand parts afforded sixty-four parts of nutritive matter, consisting nearly of one sixth of sugar, and five sixths of mucilage, with little extractive matter. In another experiment, four square yards gave twenty-seven pounds of grass. Lady Hardwicke has given an account of a trial of this grass; wherein twenty-three milch cows, and one young horse, besides a number of pigs, were kept a fortnight on the produce of one acre. On the Duke of Bedford's farm, at Maulden, fiorin hay was placed in the racks before horses, in small distinct quantities, alternately with common hay; but no decided preference for either was manifested by the horses in this trial. Fiorin has been tried in the highlands of Scotland, and a premium awarded in 1821 for a field of three acres planted on land previously worth very little, at Appin, in Argyleshire. (*Highl. Soc. Trans.* vol. vi. p. 229.) Hay-tea has also been made from fiorin, and found useful in rearing calves, being mixed with oatmeal and skimmed milk. (*Ibid.* p. 233.)

5689. *There are other species of Agróstis*, as the *A. palustris* and *repens*, and some varieties of the *A. stolonifera*, that on common soils are little different in their appearance and properties from fiorin. On one of these, the narrow-leaved creeping-bent (*A. stolonifera* var. *angustifolia*), the following remarks are made in the account of the Woburn experiments. "From a careful examination of the creeping-bent with narrow leaves, it will doubtless appear to possess merits well worthy of attention, though perhaps not so great as they have been supposed, if the natural place of its growth and habits be impartially taken into the account. From the couchant nature of this grass, it is denominated couch-grass, by practical men; and from the length of time that it retains the vital power, after being taken out of the soil, it is called squitch, quick, full of life," &c.

5690. *The culture of fiorin* is different from that of other grasses. Though the plant will ripen its seeds on a dry soil, and these seeds being very small, a few pounds would be sufficient for an acre, yet it is generally propagated by stolones or root-shoots. The ground being well pulverised, freed from weeds, and laid into such beds or ridges as the cultivator may think advisable; small drills an inch or two deep, and six or nine inches asunder, are to be drawn along its surface, with a hand or horse-hoe, or on soft lands with the hoe-rake. In the bottom of these drills, the fiorin shoots (whether long or short is of no consequence) are laid lengthways, so that their ends may touch each other, and then lightly covered with a rake, and the surface rolled to render it fit for the scythe. In six months the whole surface will be covered with verdure, and if the planting be performed early in spring, a large crop may be had in the following autumn. Any season will answer for planting, but one likely to be followed by showers and heat is to be preferred. Those who wish to cultivate this grass will consult Dr. Richardson's *New Essay on Fiorin Grass* (1813), and also *The Farmer's Magazine* for 1810-14. Our opinion is, that neither fiorin, Timothy, nor floating fescue, is ever likely to be cultivated in Britain; though the latter two may perhaps succeed well on the bogs and moist rich soils of Ireland, where, to second the influence of the soil, there is a moist warm climate.

5691. A number of other species of tall grasses, well adapted for meadows and hay making, might be here enumerated; but we have deemed it better to treat only of the most popular sorts, of which seeds may be purchased; all the others of any consequence will be found in a tabular view (Sect. III.), accompanied by a summary statement of their products in hay and aftermath, nutritive matter, and general character.

5692. The preparation of the soil, and the sowing of the usual meadow grasses, differ in nothing from those of clover and rye-grass already given. The after-treatment of dry meadows, including the making of natural hay, will be found in the succeeding Chapter on the management of grass-lands; that of watered meadows was naturally given when treating of their formation. (4431.)

SECT. II. Grasses chiefly adapted for Pasturage.

5693. In treating of pasturage grasses we shall make a selection of such as have been tried to some extent, and of which the seeds are in the course of commerce. On soils in good condition, and naturally well constituted, no better grasses can be sown for pasturage than those we have described as tall grasses for hay-meadows; but for early and late pasturage, and secondary soils, there are others much more suitable.

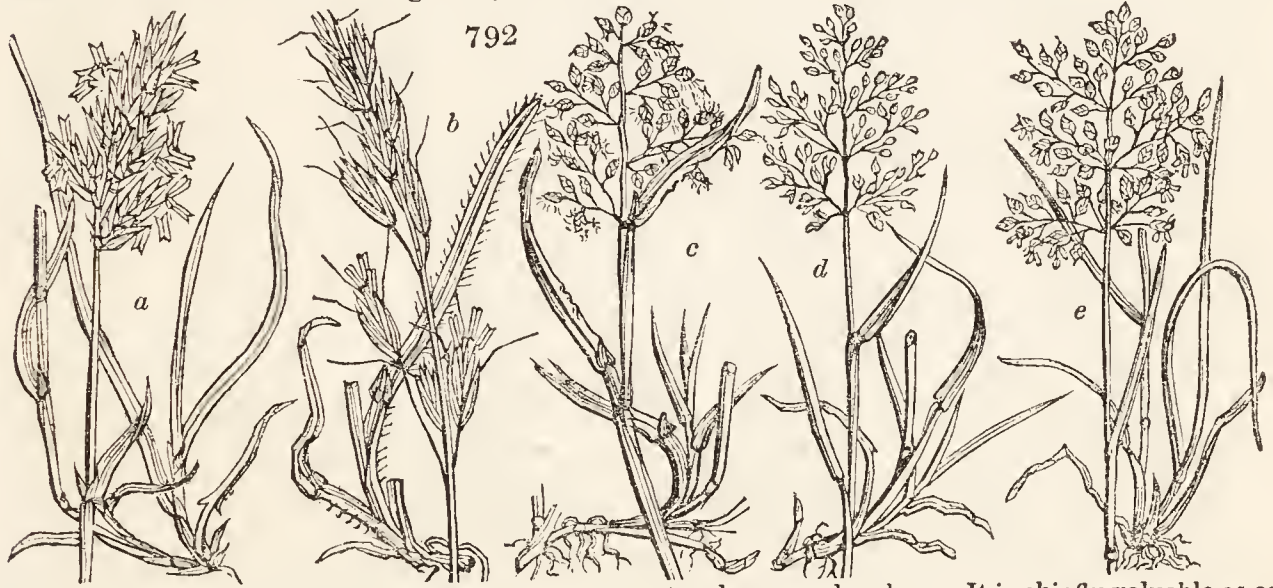
5694. The pasture grasses for early pasturage on all soils are the *Anthoxanthum odoratum*, *Hólcus odoratus*, *Avèna pubescens*, and *Pòa ànnua*.

5695. The pasture grasses for late herbage on all soils are chiefly the different species of *Agróstitis* and *Phlèum*.

5696. The pasture grasses for poor or secondary soils are the *Cynosùrus cristatus*, *Festùca duriúscula* and *ovina*, *Pòa compressa*, *cristata*, and *angustifòlia*.

5697. The grasses that afford most nutritive matter in early spring, are the fox-tail grass and the vernal grass; the former has been already mentioned as one of the best hay-grasses.

5698. The sweet-scented vernal grass (*Anthoxanthum odoratum*, fig. 792. a) is common in almost all



pastures, and is that which gives the fragrance to natural or meadow-hay. It is chiefly valuable as an early grass; for, though it is eaten by stock, it does not appear to be much relished by them. From the Woburn experiments, it appears that the smallness of the produce of this grass renders it improper for the purpose of hay; but its early growth, and the superior quantity of nutritive matter which the lattermath affords, compared with the quantity afforded by the grass at the time of flowering, cause it to rank high as a pasture-grass, on such soils as are well fitted for its growth; such are peat-bogs, and lands that are deep and moist.

5699. The downy oat grass (*Avèna pubescens*, b), according to the Woburn experiments, possesses several good qualities, which recommend it to particular notice; it is hardy, early, and more productive than many others which affect similar soils and situations. Its growth after being cropped is tolerably rapid, although it does not attain to a great length if left growing; like the *Pòa pratensis* it sends forth flower-stalks but once in a season, and it appears well calculated for permanent pasture on rich light soils.

5700. The annual meadow grass (*Pòa ànnua*, c) is the most common of all grasses, and the least absolute in its habits. It is almost the only grass that will grow in towns and near works where the smoke of coal abounds. Though an annual grass, it is found in most meadows and pastures perpetually flowering, and affording an early sweet herbage, relished by all stock, and of as great importance to birds as wheat is to man. It hardly requires to be sown, as it springs up every where of itself. However, it may not be amiss to sow a few pounds of it per acre wherever perpetual pasture (not hay) is the object.

5701. The fine bent grass (*Agróstitis vulgàris*, d) is one of the most common grasses, and, according to the Woburn experiments, one of the earliest. The *A. palústris* is nearly as early in producing its foliage, though both flower late, and neither is very prolific either in bulk or nutritive matter.

5702. The narrow-leaved meadow grass (*Pòa angustifòlia*, e), though it flowers late, yet is remarkable for the early growth of the leaves. According to the Woburn experiments the leaves attain to the length of more than twelve inches before the middle of April, and are soft and succulent; in May, however, when the flower-stalks make their appearance, it is subject to the disease termed rust, which affects the whole plant; the consequence of which is manifest in the great deficiency of produce in the crop at the time the seed is ripe, being then one half less than at the time of the flowering of the grass. Though this disease begins in the straws, the leaves suffer most from its effects, being at the time the seed is ripe completely dried up: the straws, therefore, constitute the principal part of the crop for mowing, and they contain more nutritive matter, in proportion, than the leaves. This grass is evidently most valuable for permanent pasture, for which, in consequence of its superior, rapid, and early growth, and the disease beginning at the straws, nature seems to have designed it. The grasses which approach nearest to this in respect of early produce of leaves, are the *Pòa fértilis*, *Dáctylis glomeràta*, *Phlèum pratense*, *Alopecùrus pratensis*, *Avèna elàtior*, and *Brómus littóreus*, all grasses of a coarser kind.

5703. *The best natural pastures of England, examined carefully during various periods of the season, were found by Sinclair of Woburn to consist of the following plants :—*

- | | | | |
|------------------------------|--------------------------------|------------------------------------|-------------------------|
| <i>Alopecurus pratensis.</i> | <i>Phlèum pratense.</i> | <i>Vicia sepium.</i> | <i>Poa annua.</i> |
| <i>Dactylis glomerata.</i> | <i>Anthroxanthum odoratum.</i> | <i>Lolium perenne.</i> | <i>Avena pratensis.</i> |
| <i>Festuca pratensis.</i> | <i>Holcus avenaceus.</i> | <i>Bròmus arvensis (frequent).</i> | |

These afford the principal grass in the spring, and also a great part of the summer produce :—

- | | | | |
|-----------------------------|----------------------------|----------------------------|----------------------------|
| <i>Avena flavescens.</i> | <i>Festuca duriuscula.</i> | <i>Holcus lanatus.</i> | <i>Lathyrus pratensis.</i> |
| <i>Hordeum pratense.</i> | <i>Poa trivialis.</i> | <i>Trifolium pratense.</i> | |
| <i>Cynosurus cristatus.</i> | <i>Poa pratensis.</i> | <i>Trifolium repens.</i> | |

These yield produce principally in summer and autumn :—

- | | | |
|------------------------------|--|-------------------------|
| <i>Achillea Millefolium.</i> | <i>Agròstis stolonifera and palustris.</i> | <i>Triticum repens.</i> |
|------------------------------|--|-------------------------|

These vegetate with most vigour in autumn :—

- | | | |
|--------------------------|-----------------------------|-----------------------|
| <i>Ranunculus acris.</i> | <i>Plantago lanceolata.</i> | <i>Rumex Acetosa.</i> |
|--------------------------|-----------------------------|-----------------------|

The first and last of these plants are to be considered injurious; and the other is of little value as herbage. (*Hort. Gram. Wob. 2d edit. 133.*)

5704. *The above mixture sown at the rate of four or five bushels to the acre, on well prepared soil without corn or other crop of any kind, could hardly fail of producing excellent pasture in the following year, and for an indefinite period. The best time for sowing is July or August, as spring-sown seeds are apt to suffer with the droughts of June and July. Fifteen of the above sorts are to be had from the seed-shops; and all of them may be gathered from natural pastures, or bespoke from collectors. Sinclair of Woburn, having entered into the seed and nursery business, and having expressed his intention to devote his particular attention to supplying the public with grass and other agricultural seeds, will probably render such seeds more common in commerce. (Adv. by Cormack, Son, and Sinclair.)*

5705. *Of late pasture grasses the different species of cat's-tail (Phlèum) and bent-grass (Agròstis) are the chief, and especially the Timothy and fiorin grass. The grasses, Sir H. Davy observes, that propagate themselves by stolones, the different species of Agròstis, supply pasture throughout the year; and the concrete sap, stored up in their joints, renders them a good food even in winter.*

5706. *Of pasture grasses for inferior soils one of the most durable is the dog's-tail grass (Cynosurus cristatus, fig. 793. a). This is a very common grass on dry, clayey, or firm*



surfaces. It is one of the best grasses for parks, being highly relished by the South Down sheep and deer.

5707. *The hard fescue grass (Festuca duriuscula, b) is one of the best of the dwarf sorts of grasses. It is grateful to all kinds of cattle; hares are very fond of it; at Woburn they crop it close to the roots, and neglect the Festuca ovina and Festuca rubra, which grow contiguous to it. It is present in most good meadows and pastures, and, with F. ovina, is the best for lawns.*

5708. *The Festuca glabra (c), and hordeiformis (d), greatly resemble the hard fescue, and may be considered equally desirable as pasture and lawn grasses.*

5709. *The yellow oat grass (Avena flavescens) is very generally cultivated, and appears, from the Woburn experiments, to be a very valuable grass for pasture on a clayey soil.*

5710. *Of pasture grasses for inferior soils and upland situations, one of the principal is the Festuca ovina, or sheep's fescue grass (fig. 794. a). This grass is peculiarly adapted for hilly sheep pastures. It is a low dwarf grass, but relished by all kinds of cattle. According to Sinclair's experience, "on dry soils that are incapable of producing the larger sorts, this should form the principal crop, or rather the whole; for it is seldom or never, in its natural state, found intimately mixed with others, but by itself.*



(d), and minima, and Agròstis humilis and vulgaris, are all dwarf mountain grasses, well adapted for hilly parks or lawns.

5711. *The Pòa alpina (b), Alopecurus alpinus, and Aira cæspitosa (c), Briza media*

5712. *On the culture of these grasses* it is unnecessary to enlarge, as it must obviously be the same as that of rye-grass or any of the others.

5713. *The chief difficulty is to get the seed in sufficient quantity*, for which a good mode is to contract with a seedsman, a year beforehand, for the quantity wanted. With all the pasture grasses, except the last class, we should recommend at least half the seed to be that of the perennial rye-grass; and we think it should also form a considerable part of the seeds used in laying down all meadows, except those for the aquatic or stoloniferous grasses. These, if they thrive, are sure to choak and destroy it, and therefore neither rye-grass, nor any other grass, should ever be sown with Timothy grass or florin.

5714. *The formation of grassy surfaces by distributing pieces of turf over them* has long been practised in gardening, in levelling down raised, or filling up hollow, fences, and in other cases of partially altering a grassy surface.

5715. *It is said to have been first used* in agriculture by Whitworth, of Acre-house, Lincolnshire; and in 1812 it was brought forward on a large scale by John Blomfield, of Warham, in Norfolk, a tenant of Coke's. Blomfield planted eleven acres in this way. An account of the process, which is styled transplanting turf, or inoculating land with grass, has been published by Francis Blaikie, Coke's steward. (*On the Conversion of Arable Land into Pasture*, 12mo, 1817.)

5716. *An abstract of the process of transplanting turf*, and an opinion on it, are thus given in *The Code of Agriculture*. A piece of good clean, sweet old turf, which ought principally to consist of fibrous-rooted plants, is cut into small pieces of about three inches square, and placed about six inches apart on the surface of ground prepared for that purpose. In this way one acre of turf will plant nine acres of arable land. The pieces of turf should be carefully placed with the grass side uppermost, and the plants pressed well into the ground. No more turf should be cut, carried, and spread in any one day than is likely to be planted before night. If the transplanted turf is found deficient in any particular species of favourite plants, as white clover, permanent red clover, &c. the seeds of those plants should be sown upon the young pasture in April. When the ground is in proper temper (between wet and dry) the pasture should be frequently well pressed down by heavy rollers, which will cause the plants to extend themselves along the ground rather than rise into tufts, which otherwise they would be apt to do. No stock should be permitted to feed upon the transplanted pasture in the first spring or summer, nor until the grasses have perfected and shed their seeds. Indeed the pasturing should be very moderate until the mother grass-plants and their young progeny have united and formed a compact turf. The expense of this operation is about 2*l.* 10*s.* per statute acre; without making any allowance for the charges incurred by summer fallowing the arable land on which the turf has been transplanted; nor for the year's rent, poor's rates, and taxes for that year; nor for restoring the land whence the turf plants were taken, to its previous state. This plan seems to be well calculated to promote the improvement of light soils, not naturally of a grassy nature; for the grasses and their roots being once formed on a rich soil, will probably thrive afterwards even on a poor one, as they will derive a considerable proportion of their nourishment from the atmosphere. For light and gravelly soils, therefore, where permanent pasture is desirable, the plan cannot be too strongly recommended; and if it were found to answer on peat, after the surface was pared for the reception of the plants, and burnt to promote their growth, it would be a most valuable acquisition to sheep farmers in many districts of the country. Thus far Sir John Sinclair; but, from facts related by Sinclair of Woburn, it appears to be a plan of little or no merit, and only brought into notice by its novelty. (*H. G. Wob.* 2d edit. 420, 421.)

SECT. III. *General View of the Produce, Uses, Character, and Value of the principal British Grasses, according to the Result of John Duke of Bedford's Experiments at Woburn.*

5717. *In all permanent pastures*, Sir H. Davy observes, nature has provided a mixture of various grasses, the produce of which differs at different seasons. Where pastures are to be made artificially, such a mixture ought to be imitated; and, perhaps, pastures superior to the natural ones may be formed by selecting due proportions of those species of grasses fitted for the soil, which afford respectively the greatest quantities of spring, summer, lattermath, and winter produce; a reference to the results of the Woburn experiments, he adds, will show that such a plan of cultivation is very practicable.

5718. *The manner in which these experiments were conducted* is thus described:—"Spots of ground, each containing four square feet, in the garden at Woburn Abbey, were enclosed by boards in such a manner that there was no lateral communication between the earth included by the boards, and that of the garden. The soil was removed in these enclosures, and new soils supplied; or mixtures of soils were made in them, to furnish as far as possible to the different grasses those soils which seem most favourable to their growth; a few varieties being adopted for the purpose of ascertaining the effect of different soils on the same plant. The grasses were either planted or sown, and their produce cut and collected, and dried at the proper seasons, in summer and autumn, by Sinclair, His Grace's gardener. For the purpose of determining, as far as possible, the nutritive powers of the different species, equal weights of the dry grasses or vegetable substances were acted upon by hot water till all their soluble parts were dissolved; the solution was then evaporated to dryness by a gentle heat in a proper stove, and the matter obtained carefully weighed. This part of the process was likewise conducted with much address and intelligence by Sinclair, by whom all the following details and calculations are furnished. The dry extracts supposed to contain the nutritive matter of the grasses, were sent to me for chemical examination. The composition of some of them is stated minutely; but it will be found from the general conclusions, that the mode of determining the nutritive power of the grasses, by the quantity of matter they contain soluble in water, is sufficiently accurate for all the purposes of agricultural investigation." (*Agr. Chem. app.*)

5719. *The leading results of these experiments* we have endeavoured to present in a tabular view; farther details will be found in the paragraphs (antecedent and posterior) referred to in the first column. On the other columns of the table, it may be observed, that the height is given more by a guess than measurement, and after the appearance of the plants in a state of nature or medium soils. It is to be regretted that the height of the plants was not included in the published details. The time of flowering is given as it took place at Woburn; on which it is observed, that "to decide positively the exact period or season when a grass always comes into flower, and perfects its seed, will be found impracticable; for a variety of circumstances interfere. Each species seems to possess a peculiar life in which various periods may be distinctly marked, according to the varieties of its age, of the seasons, soils, exposures, and modes of culture."

5720. *The soils*, as denominated in the column devoted to them, are thus described. 1st, By loam, is meant any of the earths combined with decayed animal or vegetable matter. 2d, Clayey loam, when the greatest proportion is clay. 3d, Sandy loam, when the greatest proportion is sand. 4th, Brown loam, when the greatest proportion consists of decayed vegetable matter. 5th, Rich black loam, when sand, clay, animal, and vegetable matters are combined in unequal proportions, the clay, greatly divided, being in the least proportion, and the sand and vegetable matter in the greatest. The terms light sandy soil, light brown loam, &c., are varieties of the above, as expressed. The abbreviations of the names of books and native soils, with all abbreviations used in this work, will be found explained in the General Index.

5722. *On the nutritive products*, Sir H. Davy has the following valuable remarks, some of which, concerning the mode in which the animal economy is operated on by the different substances composing the nutritive matter, the agriculturist will find useful, as applied to the tables before given (5000. 5190. &c.) of the nutritive products of the corns, legumes, and roots. The only substances which Sir H. Davy detected in the soluble matters procured from the grasses, are mucilage, sugar, bitter extract, a substance analogous to albumen, and different saline matters. Some of the products from the aftermath crops gave feeble indications of the tanning principle. In the experiments made on the quantity of nutritive matter in the grasses, cut at the time the seed was ripe, the seeds were always separated; and the calculations of nutritive matter made from grass and not hay.

5723. *The order in which these substances are nutritive* is thus given:—“The albumen, sugar, and mucilage, probably when cattle feed on grass or hay, are for the most part retained in the body of the animal; and the bitter principle, extract, saline matter, and tannin, when any exist, probably for the most part are voided in the excrement, with the woody fibre. The extractive matter obtained by boiling the fresh dung of cows, is extremely similar in chemical characters to that existing in the soluble products from the grasses. And some extract, obtained by Sinclair from the dung of sheep and of deer, which had been feeding upon the *Lolium perenne*, *Dactylis glomerata*, and *Trifolium repens*, had qualities so analogous to those of the extractive matters obtained from the leaves of the grasses, that they might be mistaken for each other. The extract of the dung, after being kept for some weeks, had still the odour of hay. Suspecting that some undigested grass might have remained in the dung, which might have furnished mucilage and sugar, as well as bitter extract, I examined the soluble matter very carefully for these substances. It did not yield an atom of sugar, and scarcely a sensible quantity of mucilage.” Sinclair, in comparing the quantities of soluble matter afforded by the mixed leaves of the *Lolium perenne*, *Dactylis glomerata*, and *Trifolium repens*, and that obtained from the dung of cattle fed upon them, found their relative proportions as 50 to 13.

5724. *From these facts it appears probable* that the bitter extract, though soluble in a large quantity of water, is very little nutritive; but probably it serves the purpose of preventing, to a certain extent, the fermentation of the other vegetable matters, or in modifying or assisting the function of digestion, and may thus be of considerable use in forming a constituent part of the food of animals. A small quantity of bitter extract and saline matter is probably all that is needed; and beyond this quantity the soluble matters must be more nutritive in proportion as they contain more albumen, sugar, and mucilage, and less nutritive in proportion as they contain other substances.

5725. *In comparing the composition of the soluble products afforded by different crops* from the same grass, Sir H. Davy found, in all the trials, the largest quantity of truly nutritive matter in the crop cut when the seed was ripe, and least bitter extract and saline matter; most extract and saline matter in the autumnal crop; and most saccharine matter, in proportion to the other ingredients, in the crop cut at the time of flowering.

5726. *The greater proportion of leaves in the spring*, and particularly in the late autumnal crop, accounts for the difference in the quantity of extract; and the inferiority of the comparative quantity of sugar in the summer crop probably depends upon the agency of light, which tends always in plants to convert saccharine matter into mucilage or starch. Amongst the soluble matters afforded by the different grasses, that of the *Elymus arenarius* (fig. 711. a) was remarkable for the quantity of saccharine matter it contained, amounting to more than one third of its weight. The soluble matters from the different species of *Festuca*, in general, afforded more bitter extractive matter, than those from the different species of *Poa*. The nutritive matter from the seed crop of the *Poa compressa* was almost pure mucilage. The soluble matter of the seed crop of *Phleum pratense*, or meadow cat's-tail, afforded more sugar than any of the *Poa* or *Festuca* species. The soluble parts of the seed crop of the *Holcus mollis*, and *Holcus lanatus*, contained no bitter extract, and consisted entirely of mucilage and sugar. Those of the *Holcus odoratus* afforded bitter extract, and a peculiar substance having an acrid taste, more soluble in alcohol than in water. All the soluble extracts of those grasses, that are most liked by cattle, have either a saline or subacid taste; that of the *Holcus lanatus* is similar in taste to gum arabic. Probably the *Holcus lanatus*, which is so common a grass in meadows, might be made palatable to cattle by being sprinkled over with salt.

5727. *No difference was found in the nutritive produce of the crops of the different grasses cut at the same season*, which would render it possible to establish a scale of their nutritive powers; but probably the soluble matters of the aftermath crop are always from one sixth to one third less nutritive, than those from the flower or seed crop. In the aftermath the extractive and saline matters are certainly usually in excess; but the aftermath hay mixed with summer hay, particularly that in which the fox-tail and soft grasses are abundant, would produce an excellent food.

5728. *Anthroxanthum odoratum* E. B. — The proportional value which the grass, at the time of flowering, bears to that at the time the seed is ripe, is as 4 to 13. The proportional value which the grass of the lattermath bears to that at the time the seed is ripe, is nearly as 9 to 13.

5729. *Holcus odoratus* Host, G. A. — The proportional value which the grass, at the time of flowering, bears to that at the time the seed is ripe, is as 17 to 21. The grass of the lattermath crop, and that of the crop at the time of flowering, taking the whole quantity, and their relative proportions of nutritive matter, are in value nearly as 6 to 10: the value of the grass, at the time the seed is ripe, exceeds that of the lattermath in proportion as 21 to 17. Though this is one of the earliest of the flowering grasses, it is tender, and the produce in the spring is inconsiderable. If, however, the quantity of nutritive matter which it affords be compared with that of any of those species which flower nearly at the same time, it will be found greatly superior. It sends forth but a small number of flower-stalks, which are of a slender structure compared to the size of the leaves. This will account, in a great measure, for the equal quantities of nutritive matter afforded by the grass at the time of flowering, and the lattermath.

5730. *Cynosurus cæruleus* E. B. (*Sesleria cærulea* E. of P. 1070.) — The produce of this grass is greater than its appearance would denote; the leaves seldom attain to more than four or five inches in length, and the flower-stalks seldom arise to more. Its growth is not rapid after being cropped, nor does it seem to withstand the effects of frost, which, if it happens to be severe and early in the spring, checks it so much as to prevent it from flowering for that season; otherwise, the quantity of nutritive matter which the grass affords (for the straws are very inconsiderable) would rank it as a valuable grass for permanent pasture.

5731. *Avena pubescens* E. B. (*Trisetum pubescens* E. of P. 1062.) — The proportional value which the grass at the time of flowering bears to that at the time the seed is ripe, is as 6 to 8. The proportional value which the grass at the time of flowering bears to that of the lattermath, is as 6 to 8. The grass of the seed-crop, and that of the lattermath, are of equal value. The downy hairs which cover the surface of the leaves of this grass, when growing on poor light soils, almost entirely disappear when it is cultivated on a richer soil.

5732. *Poa cærulea* var. *pratensis* E. B. — If the produce of this variety be compared with that of

Poa pratensis, it will be found less; nor does it seem to possess any superior excellence. The superior nutritive power does not make up for the deficiency of produce by 80 lbs. of nutritive matter per acre.

5733. *Festuca hordeiformis* H. Cant. — This is rather an early grass, though later than any of the preceding species: its foliage is very fine, resembling the *F. duriuscula*, to which it seems nearly allied, differing only in the length of the awns, and the glaucous colour of the whole plant. The considerable produce it affords, and the nutritive powers it appears to possess, joined to its early growth, are qualities which strongly recommend it to further trial.

5734. *Festuca glauca* Curtis. — The proportional value by which the grass at the time of flowering exceeds that at the time the seed is ripe is as 6 to 12. The proportional difference in the value of the flowering and seed crops of this grass is directly the reverse of that of the preceding species, and affords another strong proof of the value of the straws in grass which is intended for hay. The straws at the time of flowering are of a very succulent nature; but, from that period till the seed be perfected, they gradually become dry and wiry. Nor do the root-leaves sensibly increase in number or in size, but a total suspension of increase appears in every part of the plant, the roots and seed-vessels excepted. The straws of the *Poa trivialis* are, on the contrary, at the time of flowering, weak and tender; but as they advance towards the period of ripening the seed, they become firm and succulent; after that period, however, they rapidly dry up, and appear little better than a mere dead substance.

5735. *Festuca glabra* Wither. B. — The proportional value which the grass at the time the seed is ripe bears to that of the crop at the time of flowering is as 5 to 8. The proportional value which the grass of the lattermath bears to that of the crop at the time of flowering, is as 2 to 8; and to that of the crop, at the time the seed is ripe, is as 2 to 5. The general appearance of this grass is very similar to that of the *Festuca duriuscula*: it is, however, specifically different, and inferior in many respects, which will be manifest on comparing their several produce with each other; but if it be compared with some others, now under general cultivation, the result is much in its favour, the soil which it affects being duly attended to.

5736. *Festuca rubra* Wither. B. — The proportional value which the grass at the time of flowering bears to that at the time the seed is ripe is as 6 to 8. This species is smaller in every respect than the preceding. The leaves are seldom more than from three to four inches in length; it affects a soil similar to that favourable to the growth of the *Festuca ovina*, for which it would be a profitable substitute, as it will clearly appear on a comparison of their produce with each other. The proportional value which the grass of the lattermath bears to that at the time the seed is ripe is as 6 to 8, and is of equal value with the grass at the time of flowering.

5737. *Festuca ovina* E. B. — The dry weight of this species was not ascertained, because the smallness of the produce renders it entirely unfit for hay.

5738. *Festuca cambrica* Hud. — This species is nearly allied to the *Festuca ovina*, from which it differs little, except that it is larger in every respect. The produce, and the nutritive matter which it affords, will be found superior to those given by the *F. ovina*, if they are brought into comparison.

5739. *Brómus diándrus* Curt. Lond. (*B. madritensis* E. of P. 1140.) — This species, like the *Festuca cambrica*, is strictly annual; the above is therefore the produce for one year; which, if compared with that of the least productive of the perennial grasses, will be found inferior, and it must consequently be regarded as unworthy of culture.

5740. *Poa angustifolia* With. 2. — In the early growth of the leaves of this species of *Poa*, there is a striking proof that early flowering in grasses is not always connected with the most abundant early produce of leaves. In this respect, all the species which have already come under examination are greatly inferior to that now spoken of. The culms are most valuable for the manufacture of the finest straw plait.

5741. *Avèna elàtior* Curt. (*Hólcus avenàceus* E. of P. 1427.) — This grass sends forth flower-straws during the whole season; and the lattermath contains nearly an equal number with the flowering crop. It is subject to the rust, but the disease does not make its appearance till after the period of flowering; it affects the whole plant, and at the time the seed is ripe the leaves and straws are withered and dry. This accounts for the superior value of the lattermath over the seed crop, and points out the propriety of taking the crop when the grass is in flower.

5742. *Poa elàtior* Curt. — The botanical characters of this grass are almost the same as those of the *Avèna elàtior*, differing in the want of the awns only. It has the essential character of the *Hólci* (florets, male and hermaphrodite; calyx husks two-valved, with two florets); and since the *Avèna elàtior* is now referred to that genus, this may with certainty be considered a variety of it.

5743. *Festuca duriuscula* E. B. — The proportional value which the grass at the time the seed is ripe bears to that at the time of flowering, is as 6 to 14 nearly. The proportional value which the grass of the lattermath bears to that at the time of flowering, is as 5 to 14; and to that at the time the seed is ripe as 5 to 6. The above particulars will confirm the favourable opinion which was given of this grass when speaking of the *F. hordeiformis*, and *F. glabra*. (5733. and 5735.) Its produce in the spring is not very great, but of the finest quality, and at the time of flowering is considerable. If it be compared with those affecting similar soils, such as *Poa pratensis*, *Festuca ovina*, &c. either considered as a grass for hay or permanent pasture, it will be found of greater value.

5744. *Mílum effusum*. — This species in its natural state seems confined to woods as its place of growth; but the trial that is here mentioned confirms the opinion that it will grow and thrive in open exposed situations. It is remarkable for the lightness of the produce in proportion to its bulk. It produces foliage early in the spring in considerable abundance; but its nutritive powers appear comparatively little.

5745. *Poa marítima* E. B. — The proportional value which the grass of the lattermath bears to that at the time of flowering, is as 4 to 18.

5746. *Avèna pratensis* E. B. — The proportional value which the crop, at the time the seed is ripe, bears to that at the time of flowering, is as 4 to 9.

5747. *Brómus multiflorus* E. B. — This species is annual, and no valuable properties have as yet been discovered in the seed. It is only noticed on account of its being frequently found in poor grass lands, and sometimes in meadows. It appears, from the above particulars, to possess nutritive powers equal to some of the best perennial kinds, if taken when in flower; but if left till the seed be ripe (which, from its early growth, is frequently the case), the crop is comparatively of no value, the leaves and straws being then completely dry.

5748. *Festuca loliiæca* Curt. Lond. — The proportional value which the grass, at the time of flowering, bears to that at the time the seed is ripe, is as 12 to 13; and the value of the lattermath stands in proportion to that of the crop, at the time of flowering, as 5 to 12; and to that of the crop taken at the time the seed is ripe, as 5 to 13. This species of *Festuca* greatly resembles the rye-grass, in habit and place of growth; it has excellences which make it greatly superior to that grass, for the purposes of either hay or permanent pasture. This species seems to improve in produce in proportion to its age, which is directly the reverse of the *Lólium perénne*.

5749. *Poa cristàta* Host, G. A. — The produce of this species, and the nutritive matter that it affords, are equal to those of the *Festuca ovina*, at the time the seed is ripe: they equally delight in dry soils. The greater bulk of grass, in proportion to the weight, with the comparative coarseness of the foliage, renders the *Poa cristàta* inferior to the *Festuca ovina*.

5750. *Festuca Myúrús* E. B. (*Mygalúrús caudàtus* E. of P. 1118.) — This species is strictly annual; it is likewise subject to the rust; and, the produce being but little, it ranks as a very inferior grass.

5751. *Festuca calamària* E. B. — The proportional value which the grass, at the time the seed is ripe, bears to that at the time of flowering, is as 12 to 18. This grass, as has already been remarked, produces

a fine early foliage in the spring. The produce is very great, and its nutritive powers are considerable. It appears, from the above particulars, to be best adapted for hay. A very singular disease attacks, and sometimes nearly destroys, the seed of this grass: the cause of this disease seems to be unknown; it is denominated *clavus* by some; it appears by the seed swelling to three times its usual size, in length and thickness, and the want of the corcle. Dr. Willdenow describes two distinct species of it: first, the simple *clavus*, which is mealy and of a dark colour, without any smell or taste; secondly, the malignant *clavus*, which is violet blue, or blackish, and internally too has a bluish colour, with a fetid smell, and a sharp pungent taste. Bread made from grain affected with this last species, is of a bluish colour; and when eaten, produces cramps and giddiness.

5752. *Brōmus littōreus* Host, G. A. — The proportional value which the grass, at the time of flowering, bears to that at the time the seed is ripe, is as 6 to 14. This species greatly resembles the preceding, in habit and manner of growth; but is inferior to it in value, which is evident from the deficiency of its produce, and of the nutritive matter afforded by it. The whole plant is likewise coarser, and of greater bulk in proportion to its weight. The seed is affected with the same disease which destroys that of the former species.

5753. *Festūca fluitans* Curt. Lond. (*Glycēria fluitans* E. of P. 1090.) — The above produce was taken from grass that had occupied the ground for four years; during which time it had increased every year. It appears, therefore, contrary to what some have supposed, to be capable of being cultivated in perennial pastures.

5754. *Pōa fertilis* Host, G. A. — If the nutritive powers and produce of this species be compared with any other of the same family, or such as resemble it in habit and the soil which it affects, a superiority will be found, which ranks this as one of the most valuable grasses. Next to the *Pōa angustifolia*, it produces the greatest abundance of early foliage, of the best quality, which fully compensates for the comparative lateness of flowering.

5755. *Arūdo colorata* Hort. Kew. — The strong nutritive powers which this grass possesses recommend it to the notice of occupiers of strong clayey lands which cannot be drained. Its produce is great, and the foliage will not be denominated coarse, if compared with grasses which afford a produce equal in quantity.

5756. *Hōrdeum pratense* E. B. — The specific characters of this species are much the same as those of the *Pōa fertilis*, differing in the compressed figure of the straws and creeping root only. If the produce were of magnitude, it would be one of the most valuable grasses; for it produces foliage early in the spring, and possesses strong nutritive powers.

5757. *Avēna flavescens* Curt. Lond. (*Trisetum flavescens* E. of P. 1060.) — The proportional value which the grass, at the time the seed is ripe, bears to that at the time of flowering, is as 9 to 15. The proportional value which the grass of the lattermath bears to that at the time of flowering, is as 5 to 15; and to that at the time the seed is ripe, as 5 to 9.

5758. *Brōmus stērilis* E. B. — 64 dr. of the flowers afford of nutritive matter 2·2 dr. The nutritive powers of the straws and leaves are, therefore, more than twice as great as those of the flowers. This species, being strictly annual, is of comparatively little value. The above particulars show that it has very considerable nutritive powers, more than its name would imply, if taken at the time of flowering; but if left till the seed be ripe, it is, like all other annuals, comparatively of no value.

5759. *Hōlcus mollis*. — 64 dr. of the roots afford of nutritive matter 5·2 dr. The proportional value which the grass, at the time the seed is ripe, bears to that at the time of flowering, is as 14 to 18. The above details prove this grass to have merits, which, if compared with those of other species, rank it with some of the best grasses. The small loss of weight which it sustains in drying might be expected from the nature of the substance of the grass; and the loss of weight at each period is equal. The grass affords the greatest quantity of nutritive matter when in flower, which makes it rank as one of those best adapted for hay.

5760. *Pōa fertilis* var. β . Host, G. A. — The proportional value which the grass, at the time of flowering, bears to that at the time the seed is ripe, is as 12 to 20. The proportional value which the grass of the lattermath bears to that at the time of flowering, is as 6 to 12; and to that at the time the seed is ripe, as 6 to 20.

5761. *Phlēm noddsum* Wither. — This grass is inferior in many respects to the *Phlēm pratense*. It is sparingly found in meadows. From the number of bulbs which grow out of the straws, a greater portion of nutritive matter might have been expected. This seems to prove that these bulbs do not form so valuable a part of the plant as the joints, which are so conspicuous in the *Phlēm pratense*, the nutritive powers of which exceed those of the *P. noddsum* as 8 to 28.

5762. *Agrōstis vulgaris* Wither. — This is one of the most common of the bents, and likewise the earliest; in these respects it is superior to all others of the same family, but inferior to several of them in produce, and the quantity of nutritive matter it affords. As the species of this family are generally rejected by the cultivator, on account of the lateness of their flowering; and this circumstance, as has already been observed, does not always imply a proportional lateness of foliage, their comparative merits in this respect may be better seen, by bringing them into one view, as to the value of their early foliage.

	The apparent Difference of Time.	Their nutritive Powers.		The apparent Difference of Time.	Their nutritive Powers.
<i>Agrōstis vulgaris</i>	- Middle of April	- 1·2 $\frac{3}{4}$	<i>Agrōstis nivea</i>	- Three weeks later	- 2
<i>paūstris</i>	- One week later	- 2·3	<i>littoralis</i>	- Ditto ditto	- 3
<i>stolonifera</i>	- Two ditto	- 3·2	<i>repens</i>	- Ditto ditto	- 3
<i>canina</i>	- Ditto ditto	- 1·3	<i>mexicana</i>	- Ditto ditto	- 2
<i>stricta</i>	- Ditto ditto	- 1·2	<i>fascicularis</i>	- Ditto ditto	- 2

5763. *Panicum sanguinale* E. B. — This species is strictly annual; and from the results of this trial, its nutritive powers appear to be very inconsiderable.

5764. *The grasses which afford the best culms for straw plait* are, according to Sinclair, as follow: —

For heath or moor soil. *Festuca ovina*, *duriuscula*, and *hordeiformis*, *Nardus stricta*.

Dry soils. *Cynosurus cristatus*, *Pōa angustifolia*, *Hōrdeum pratense*, *Antioxanthum odoratum*, *Agrōstis lobata*, *spica venti*, *flavescens*, and *vulgaris mutica*, *Avēna pubescens*, *Festuca heterophylla*.

Moist soils. *Agrōstis canina*, *fascicularis*, *canina mutica*, *stolonifera angustifolia*, *stolonifera cristata*, *alba*, *stricta*, *repens*, *Pōa nemoralis*, *angustifolia*.

Cereal grasses. Wheat, spelt-wheat, rye, and oats have been sown on poor soils, and cut green and bleached; but are found inferior to the above grasses for the finest plait.

5765. *The period for cutting the culms* is when they are in blossom. They are bleached by pouring boiling water over them, in which they remain ten minutes, and are afterwards spread on a grass-plot for seven or eight days. Sinclair found that by letting the culms remain in hot water from one to two hours, only two or three days' bleaching was required. When bleached, they are taken up, washed clean, and put in a moist state in a close vessel, where they are subjected to the fumes of burning sulphur for two hours. Green culms, immersed for ten minutes in a strong solution of acetic acid, and then subjected to the sulphureous acid gas, are bleached perfectly white in half an hour. Green culms, immersed for fifteen minutes in muriatic acid, diluted with twenty times its measure of water, and then spread on the grass, became in four days as perfectly bleached as those culms which were scalded and bleached eight days on the grass. The texture of the straw was not in the least injured by these processes. The application of the sulphureous acid gas to the moistened culms, even after scalding and bleaching on the grass, had, in every instance, the effect of greatly improving the colour, and that without being productive of the smallest injury to the texture of the straw. (*Hort. Gram. Wob.* 2d edit. 427.)

5766. *To imitate the Leghorn plait in the most perfect manner*, the straws should be plaited the reverse way of the common English split-straw plait. In the English plait, the straws are flattened by a small hand-mill made for the purpose; but the Leghorn plait has the straws worked without flattening, and pressure is applied after the plait is made. It is essential that these two points should be observed by those who wish to rival the finest Leghorn manufacture. By reversing the common mode of plaiting, the fingers have a much greater power in firmly and intimately knitting the straws; and the round or unflattened state of the straws allows of their being more closely knitted, — a circumstance that gives an appearance similar to the real Leghorn plait. (*Ibid.*) The varieties of wheat or rye already mentioned (5052, and 5057.) are now generally considered far preferable to any of the forage grasses for the purposes of straw plait.

CHAP. VII.

Management of Lands permanently under Grass.

5767. *In every country by far the greater proportion of perennial grass lands is the work of nature*: and it is not till an advanced period in the progress of agriculture that much attention is paid to their management. But as the extension of tillage, planting, and the formation of parks and gardens, limit the range of the domestic animals, their food becomes more valuable; and it then becomes an object to increase it by the culture of roots and artificial herbage on some lands, and by the improved management of the spontaneous productions of others. In a highly cultivated country like Britain, therefore, those lands retained in grass either are, or ought to be, such as are more valuable to the owners in that state than they would be in any other. Such lands naturally divide themselves into two classes: those which are fit either for mowing or pasture; and those which are fit for pasture only.

SECT. I. *Perennial Grass Lands fit for mowing, or Meadow Lands.*

5768. *Under the term meadow*, we include all such land as is kept under grass chiefly for the sake of a hay crop, though occasionally, and at particular seasons of the year, it may be depastured by the domestic animals; and we usually include under this term the notion of a greater degree of moisture in the soil, than would be thought desirable either for permanent pasture or lands in tillage. Where hay is in great demand, as near large towns, and especially if a good system of cropping is but little understood, a great deal of arable land may be seen appropriated to hay-crops; but the most valuable meadows are such as are either naturally rather moist, or are rendered so by means of irrigation. There are three descriptions of these meadows: those on the banks of streams and rivers; those on the uplands, or more elevated grounds; and bog-meadows; and each of these kinds may be stocked with grasses, either naturally or by art, and may be irrigated by one or other of the different watering processes already described.

5769. *River-meadows*, or those which are situated in the bottoms of valleys, are in general by far the most valuable. They are the most productive of grass and hay, yielding sustenance for cattle through the summer and the winter, and producing an everlasting source of manure for the improvement of the adjoining lands.

5770. *The soil is deep, and commonly alluvial*, having been deposited by water, or washed down from the adjoining eminences; the surface is even, from the same cause; and, what is of considerable importance, it has a gradual declivity or surface-drainage to the river or stream which almost invariably flows in the lowest part of every valley, and which is essential to this description of meadow. The principal defects to which such lands are liable are, the oozing out of springs towards their junction with the rising lands, and the inundations of the river or stream. The former evil is to be remedied by under-draining, and the latter by embanking. Such meadows are generally stocked with the best grasses; and their culture consists of little more than forming and keeping open a sufficient number of surface-gutters or furrows to carry off the rain-water; rooting out such tufts of rushes, or bad grasses and herbage, as may occasionally appear; destroying moles, and spreading the earth they throw up; removing heavy stock whenever their feet poach the surface; shutting up, bush-harrowing, and rolling at the commencement of the growing season; and finally so adjusting the mowing and pasturing as to keep the land in good heart without laying on manure.

5771. *The most suitable meadows for irrigation* are of this description; the necessary drains and other works are executed with greater care, and with less expense; and the management, as we have seen (4380.), is also comparatively easier than in watering sloping surfaces.

5772. *Upland meadows*, or mowing lands, are next in value to those of valleys.

5773. *The soil is either naturally good*, and well adapted for grass, or, if inferior by nature, it is so situated as to admit of enrichment by ample supplies of manure. Of this last description are the upland meadows or hay lands of Middlesex; which, though on the most tenacious, and often stony clays, are yet, by the abundance of manure obtained from the metropolis, rendered as productive as the best upland soils employed as hay lands. The roots of perennial grasses, whether fibrous or creeping, never strike deep into the soil; and thus, deriving their nourishment chiefly from the surface, top-dressings, of well-rotted manure, repeated on the same field for centuries, form at last a thin black stratum among the roots of the grass, which produces the most luxuriant crops.

5774. *The culture of upland meadows* requires more attention and expense than that of valleys; being more difficult to drain, and requiring regular supplies of manure. The irregular surface of uplands is apt either to contain springs or to stagnate the surface water; the first produce marsh plants and coarse herbage, and the latter destroys or weakens whatever is growing on the surface, and encourages the growth of moss. Both evils are to be remedied by the obvious resources of drainage. Moss is a very common enemy to grass lands, and is only to be effectually destroyed by rich dressings of manure. Rolling, and top-dressings of lime and salt, have been recommended for destroying it; but there is no mode by

which it can be subdued and kept under, but by adding strength to the grass plants, and thereby enabling them to suffocate their enemy. Moss is never found on rich lands unless they are completely shaded by trees. Besides mole-hills, upland meadows, when neglected, are frequently troubled with ants, which form heaps or hillocks of grass and earth, more injurious and more difficult to get quit of than those of moles. The mode of taking moles is a simple operation, and will be described in the proper place; that of destroying ants is more complicated and tedious, and, being peculiar to grass lands, shall here be described.

5775. *Ant-hills, or habitations*, are injurious to meadow lands, by depriving the farmer of a crop in proportion to the surface they occupy, and by interfering with the operations of rolling and mowing. They consist of little eminences, composed of small particles of sand or earth, lightly and artfully laid together, which may often be computed at a tenth part, or more, of old grass-lands. In some places, where negligence has suffered them to multiply, almost half the land has been rendered useless; the hills standing as thick together as grass-cocks in a hay-field: and what is very surprising, this indolence is defended by some, who affirm, that the area or superficies of their land is thereby increased; whereas it is well known that very little or no grass ever grows thereon, and, therefore, if the surface is increased, the produce is proportionably decreased.

5776. *In order to remove ant-hills*, and destroy the insects, it has been a custom in some places, at the beginning of winter, and often when the weather was not very cold, to dig up the ant-hills three or four inches below the surface of the ground, and then to cut them in pieces, and scatter the fragments about; but this practice only disseminates the ants, instead of destroying them, as they hide themselves among the roots of the grass for a little time, and then collect themselves together again upon any little eminence, of which there are great numbers ready for their purpose, such as the circular ridges round the hollows where the hills stood before. It is, therefore, a much better method to cut the hills entirely off, rather lower than the surface of the land, and to let them lie whole at a little distance, with their bottom upwards; by this means the ants, which are known to be very tenacious of their abodes, continue in their habitations until the rains, by running into their holes of communication, and stagnating in the hollows formed by the removal of the hills, and the frosts, which now readily penetrate, destroy them. If a little soot were thrown on the places, and washed in with the rains, it would probably contribute greatly to the intended effect. The hills, when rendered mellow by the frosts, may be broken and dispersed about the land. By this method of cutting the hills, one other advantage is gained; the land soon becomes even and fit for mowing, and the little eminences being removed, the insects are exposed to the wet, which is very disagreeable and destructive to them. It would, perhaps, be a better practice than that of suffering the hills to remain on the ground, to collect the parts of them which have been pared off into a heap, in some convenient place, and then form them into a compost, by mixing a portion of quick-lime with them. In wet weather these insects are apt to accumulate heaps of sandy particles among the grass, called by labourers sprout-hills, which quickly take off the edge of the scythe. These hills, which are very light and compressible, may be conveniently removed by frequent heavy rolling.

5777. *In the Norfolk mode of cutting and burning ant-hills*, the process is, to cut them up with a heart-shaped sharp spade or shovel, in irregular lumps of from ten to fifteen inches in diameter, and from two to five or six inches thick. These are to be turned the grass-side downwards, until the mould-side is thoroughly dry, and then to be set the grass-side outwards, until they are dry enough to burn. The fire may be kindled with brushwood, and kept smothering, by laying the sods or lumps on gradually, as the fire breaks out, until ten or fifteen loads of ashes are raised in one heap, which the workmen formerly completed for a shilling or eighteen-pence each load of ashes. The places from which the hills have been removed may be sown with grass-seeds. Besides the destruction of the ants, this is a ready, though by no means an economical, way of raising manure, and in some cases ought not to be neglected, on grounds where such a process is required.

5778. *What is called "gelding" ant-hills* is thus described:—With a turving-iron make two cuts across the hill at right angles to each other; then turn back the four quarters thus obtained from off the hill, leaving it bare; next cut out and throw to a distance the interior earth of the hill with all the ants; turning their winter's hoard of provision, as well as all their excavated abode, to the very bottom. Now return the quarters of turf to their former place, treading them down to form a basin to hold the winter's rain, which will prevent the settlement of any new colony of the ants, and they, being thrown on the surface, will perish by the frost.

5779. *Where grass lands are sufficiently rolled* with a heavy roller once or oftener every year, no ant-hills will ever be formed greater than the roller can compress, and consequently no injury will be sustained. In this, as in most other cases of disease, proper regimen is the best cure. In domestic economy, various directions are given for destroying bugs, lice, and other vermin; but who ever had any to destroy, who attended properly to cleanliness?

5780. *The surface of some grass lands that have been long rolled* is apt to get into that tenacious state denominated hide bound. When this is the case, scarifying the turf with a plough, consisting only of coulter, or harrow-teeth, or, in preference to all other implements, with Wilkie or Kirkwood's brakes, so that the whole surface may be cut or torn, is to be recommended. That tenacious state, rolling tends to increase; whereas, by scarifying, the surface is loosened, and the roots acquire new means of improved vegetation. This operation seems particularly useful, when it precedes the manuring. When hay land of a retentive quality is depastured by cattle or horses in wet seasons, it receives much injury from their feet, and becomes what is technically called poached. Every step they take leaves an impression, which fills with rain water, and then the hole stands full like a cup. This wetness destroys the herbage, not only in the hole, but that also which surrounds it, while at the same time the roots of the grasses, as well as the ground, are chilled and injured. No good farmer, therefore, will permit any cattle to set a foot on such land in wet weather, and few during the winter months, on any consideration. Sheep are generally allowed to pasture on young grasses in dry weather, from the end of autumn to the beginning of March; they are then removed, and it rarely happens that any animal is admitted till the weather be dry, and the surface so firm as to bear their pressure without being poached or injured.

5781. *In manuring upland meadows*, the season, the sort, the quantity, and the frequency of application are to be considered.

5782. *With regard to the season at which manure should be applied*, a great difference of opinion prevails among the farmers of England. In the county of Middlesex, where almost all the grass lands are preserved for hay, the manure is invariably laid on in October (*Middlesex Report*, p. 224.), while the land is sufficiently dry to bear the driving of loaded carts without injury, and when the heat of the day is so moderated as not to exhale the volatile parts of the dung. Others prefer applying it immediately after the hay-time, from about the middle of July to the end of August, which is said to be the "good old time" (*Com. to Board of Agriculture*, vol. iv. p. 138.); and if that season is inconvenient, any time from the beginning of February to the beginning of April. (*Dickson's Practical Agriculture*, vol. ii. p. 915.) It is, however, too common a practice to carry out the manure during frosty weather, when, though the ground is not cut up by the carts, the fertilising parts of the dung are dissipated, and washed away by the snow and rains before they can penetrate the soil.

5783. *There is scarcely any sort of manure that will not be useful when laid on the surface of grass grounds*; but, in general, those of the more rich dung kinds are the most suitable for the older sort of sward lands; and dung, in composition with fresh vegetable earthy substances, the most useful in the new leys or grasslands. In Middlesex it is the practice of the best farmers to prefer the richest dung they can procure, and seldom to mix it with any sort of earthy material, as they find it to answer the best with regard to the quantity of produce, which is the principal object in view; the cultivators depending chiefly for the

sale of their hay in the London markets. It is the practice to turn over the dung that is brought from London in a tolerable state of rottenness, once chopping it well down in the operation, so as to be in a middling state of fineness when put upon the land. It is necessary, however, that it should be in a more rotten and reduced state when applied in the spring, than when the autumn is chosen for that purpose. (*Dickson's Practical Agriculture*, vol. ii. p. 915.)

5784. *Some interesting experiments have been made with different kinds of manure*, for the purpose of ascertaining their effects, with regard to the quantity and quality of the produce on different kinds of land. Fourteen lots, of half an acre each, were thus manured, and the grass was made into hay, all as nearly alike as possible. The greatest weight of hay was taken from the lot manured with horse, cow, and slaughterhouse dung, all mixed together, of each about an equal quantity. It lay in that state about two months; and was then turned over, and allowed to lie eight or ten days more, after which it was put on the land before it had done fermenting, and spread immediately. To ascertain the quality of the produce of the different lots, a small handful from each was laid down on a dry clean place, where there was little or no grass, and six horses were turned out to them one after another. In selecting the lots, there seems to have been little difference of taste among the horses; and all of them agreed in rejecting two lots, one of which had been manured with blubber mixed with soil, and the other with soot, in both instances laid on in the month of April preceding. (*Lancashire Report*, p. 130. *et seq.*)

5785. *The proportion of manure* that is necessary must, in a great measure, depend upon the circumstances of the land, and the facility of procuring it. In the district of London, where the manure is of a very good and enriching quality, from its being produced in stables and other places where animals are highly fed, the quantity is usually from four or five to six or seven loads on the acre, such as are drawn by three or four horses, in their return from taking up the hay to town. (*Dickson's Pract. Agr.* vol. ii. p. 916.)

5786. *Manure is laid on at intervals of time* more or less distant, according to the same circumstances that determine the quantity of it. Though there are some instances of hay grounds bearing fair crops every year during a length of years, without any manure or any advantage from pasturage, except what the after-grass has afforded (*Marshal's Review of Reports to the Board of Agriculture*, p. 183. *Western Department*); yet, in general, manure must either be allowed every third or fourth year, in the land depastured one year, and mown the other; "or, what is better, depasture two years, and mow the third." (*Northumberland Report*, p. 111.) A succession of hay crops without manure, or pasturage, on meadows not irrigated, is justly condemned by all judicious farmers, as a sure means of impoverishing the soil.

5787. *Bog meadows* are the least valuable of any: they are of two kinds; peat bogs, and earthy bogs.

5788. *Peat bogs* are situated in hollows or basins, which, from having no natural outlet for water, and not being so deep or so plentifully supplied with that element as to constitute lakes, becomes filled up with aquatic plants and mosses. By the decay of these after a certain time, and the drainage and culture of art, a surface of mossy soil is formed on which some of the inferior grasses may be sown or will spring up naturally. In warm moist climates, and where the mould of the bog is rich, florin or Timothy grass may be found to answer; but in general the woolly soft grass and cock's-foot are resorted to, unless indeed lime be applied, or a coating of sand or earth, in which cases the clovers and better grasses will sometimes answer. These bogs are in general too soft for pasturing any other animals than sheep.

5789. *Earthy bog meadows* are situated either in hollows or on slopes. They are formed by an accumulation of water in the subsoil, which not finding a free passage in any one point, spreads under and filtrates upwards through a considerable extent of surface. The grasses on such meadows before they are drained are chiefly of the sprot or *Juncus* kind; but by draining the quality of these is improved, and better kinds appear. Such meadows yield a considerable produce of coarse hay; they abound chiefly in cold hilly districts devoted to breeding.

5790. *The culture and management of bog meadows* differ in nothing essential from those of the river kinds. A lighter roller is used in spring, the greatest care is taken in eating down the latter grass, whether with small cattle or sheep; and in some cases, in very dry weather in summer, the main drains are dammed up for a few weeks in order to stagnate the water, and supply the soil with moisture. No manure is ever given unless in the case of some cultivated peat bogs, which are dressed with earthy or saline mixtures.

5791. *As branches of culture common to every description of hay lands* may be mentioned, the hay-making, the application of the after-grass, and pasturage.

5792. *The making of natural or meadow hay* has been carried to greater perfection in the neighbourhood of London than any where else; and it may therefore, with great propriety, be recommended as an example to the rest of the kingdom. The following account of it is drawn from *Middleton's Agricultural Survey of Middlesex*:

5793. *When the grass is nearly fit for mowing*, the Middlesex farmer endeavours to select the best mowers, in number proportioned to the quantity of his grass and the length of time it would be advisable to have it in hand; which having done, he lets it out, either as piece-work, or to be mown by the acre. In the latter way, each man mows from one acre and a half to an acre and three quarters per day; some there are who do two acres per day during the whole season. About the same time he provides five hay-makers (men and women, including loaders, pitchers, stackers, and all others) to each mower. These last are paid by the day, the men attending from six till six, but the women only from eight till six. For an extra hour or two in the evening, when the business requires despatch, they receive a proportionate allowance.

5794. *The mowers usually begin their work at three, four, or five o'clock in the morning*, and continue to labour till seven or eight at night; resting an hour or two in the middle of the day. Every hay-maker is expected to come provided with a fork and a rake of his own; nevertheless, when the grass is ready, and labourers scarce, the farmer is frequently obliged to provide both, but for the most part only the rake. Every part of the operation is carried on with forks, except clearing the ground, which is done with rakes; and loading the carts, which is done by hand.

5795. *First day.* All the grass mown before nine o'clock in the morning is teded, in which great care is taken thoroughly to loosen every lump, and to strew it evenly over all the ground. By this regular method of teding grass for hay, the hay will be of a more valuable quality, heat more equally in the stack, and will consequently not be so liable to damage or fire; will be of greater quantity when cut into trusses, and will sell at a better price; for when the grass is suffered to lie a day or two before it is teded out of the swath, the upper surface is dried by the sun and winds, and the interior part is not dried, but withered, so that the herbs lose much, both as to quality and quantity, which are very material circumstances. Soon after the teding is finished, the hay is turned with the same degree of care and attention; and if, from the number of hands, they are able to turn the whole again, they do so, or at least as much of it as they can, till twelve or one o'clock, at which time they dine. The first thing to be done after dinner is to rake it

into what are called single wind-rows; and the last operation of this day is to put it into grass-cocks.

5796. *Second day.* The business of this day commences with teding all the grass that was mown the first day after nine o'clock, and all that was mown this day before nine o'clock. Next, the grass-cocks are to be well shaken out into staddles (or separate plots) of five or six yards' diameter. If the crop should be so thin and light as to leave the spaces between these staddles rather large, such spaces must be immediately raked clean, and the rakings mixed with the other hay, in order to its all drying of a uniform colour. The next business is to turn the staddles, and after that, to turn the grass that was teded in the first part of the morning, once or twice, in the manner described for the first day. This should all be done before twelve or one o'clock, so that the whole may lie to dry while the work-people are at dinner. After dinner, the first thing to be done is to rake the staddles into double wind-rows; next, to

rake the grass into single wind-rows; then the double wind-rows are put into bastard-cocks; and lastly, the wind-rows are put into grass-cocks. This completes the work of the second day.

5797. *Third day.* The grass mown and not spread on the second day, and also that mown in the early part of this day, is first to be tedded in the morning, and then the grass-cocks are to be spread into staddles as before, and the bastard-cocks into staddles of less extent. These smaller staddles, though last spread, are first turned, then those which were in grass-cocks; and next the grass is turned once or twice before twelve or one o'clock, when the people go to dinner as usual. If the weather has proved sunny and fine, the hay which was last night in bastard-cocks will this afternoon be in a proper state to be carried; but if the weather should, on the contrary, have been

cool and cloudy, no part of it probably will be fit to carry. In that case, the first thing set about after dinner, is to rake that which was in grass-cocks last night into double wind-rows; then the grass which was this morning spread from the swaths into single wind-rows. After this, the hay which was last night in bastard-cocks, is made up into full-sized cocks, and care taken to rake the hay up clean, and also to put the rakings upon the top of each cock. Next, the double wind-rows are put into bastard-cocks, and the single wind-rows into grass-cocks, as on the preceding days.

5798. *Fourth day.* On this day the great cocks, just mentioned, are usually carried before dinner. The other operations of the day are such, and in the same order, as before described, and are continued daily until the hay harvest is completed.

5799. *As general rules,* the grass should, as much as possible, be protected both day and night, against rain and dew, by covering. Care should also be taken to proportion the number of hay-makers to that of the mowers, so that there may not be more grass in hand at any one time than can be managed according to the foregoing process. This proportion is about twenty hay-makers (of which number twelve may be women) to four mowers; the latter are sometimes taken half a day to assist the former. But in hot, windy, or very drying weather, a greater proportion of hay-makers will be required than when the weather is cloudy and cool. It is particularly necessary to guard against spreading more hay than the number of hands can get into cocks the same day, or before rain. In showery and uncertain weather, the grass may sometimes be suffered to lie three, four, or even five days in swath. But before it has lain long enough for the under side of the swath to become yellow (which, if suffered to lie long, would be the case), particular care should be taken to turn the swaths with the heads of the rakes. In this state, it will cure so much in about two days, as only to require being tedded a few hours when the weather is fine, previously to its being put together and carried. In this manner hay may be made and put into the stack at a small expense, and of a moderately good colour; but the tops and bottoms of the grass are insufficiently separated by it.

5800. *The hay-tedding machine* has been invented since Middleton described the hand process as above. This machine (*fig. 372.*) is found to be a most important saving of manual labour. It is computed that a boy and horse with the machine will ted as much in an hour as twelve or fifteen women. The hay-rake, which may be added to the same axle when the tedder is removed, is also an equal saving, and a requisite accompaniment to it; as where few or no women are kept for tedding, there must necessarily be a deficiency of rakers. These machines are coming into general use near London, where the price of manual labour is high and hands sometimes scarce. They are also finding their way among the proprietors of extensive parks in all parts of the country, as saving much labour in making hay from natural pasture.

5801. *There are no hay-stacks* more neatly formed, nor better secured, than those made in Middlesex. At every vacant time, while the stack is carrying up, the men are employed in pulling it, with their hands, into a proper shape; and, about a week after it is finished, the whole roof is properly thatched, and then secured from receiving any damage from the wind, by means of a straw rope, extended along the eaves, up the ends, and on each side of the ridge. The ends of the thatch are afterwards cut evenly below the eaves of the stack, just of sufficient length for the rain-water to drip quite clear of the hay. When the stack happens to be placed in a situation which may be suspected of being too damp in the winter, a trench, of about six or eight inches deep, is dug round and nearly close to it, which serves to convey all the water from the spot, and renders it perfectly dry and secure.

5802. *During the hay harvest* it is of great advantage to the farmer, to give constant personal attendance on every party, directing each operation as it goes on. The man who would cure his hay in the best manner, and at a moderate expense, must not only urge the persons who make the hay, the men who load the waggons, and those who make the stack, but he should be on the alert, to contrive and point out the manner in which every person may do his labour to the most advantage. Unless he does this, one moiety of the people in his hay-field will be of no material use to him; and if he should be absent for an hour or more, during that time little or nothing will be done. The farmers of Middlesex engage many hay-makers. Some of them have been known to employ two or three hundred; such men find it necessary to be on horseback, and the work-people find them sufficient employment. A man of energy will make the most of every hour, and secure his hay while the sun shines; one of an opposite description lounges his time away, and suffers his hay to be caught in the rain, by which it is frequently half spoiled. Or if the latter should have the good fortune of a continuance of dry weather, his hay will be a week longer in the field than his neighbour's, and the sap of it dried up by the sun.

5803. *The waste of grass, on being dried into hay,* is supposed to be three parts in four by the time it is laid on the stack; it is then further reduced, by heat and evaporation; in about a month, perhaps one twentieth more; or 600 lb. of grass are reduced to 95 lb. of hay, and between that and 90 it continues through the winter. From the middle of March till September, the operations of trussing and marketing expose it so much to the sun and wind, as to render it considerably lighter, probably 80; that is, hay which would weigh 90 the instant it is separated from the stack, would waste to 80 (in trussing, exposure on the road, and at market for about 24 hours), by the time it is usually delivered to a purchaser. During the following winter, the waste will be little or nothing. It is nearly obvious, that the same hay will weigh on delivery 80 in summer, and 90 in winter. From this circumstance, and others which relate to price, a farmer may determine what season of the year is the most advisable for him to sell his hay.

5804. *In making the hay of bog meadows,* considerable care is requisite both from the inferiority of the climates where such bogs abound, and from the nature of the grasses they produce. In some cases, the grass is of so soft a quality, that it is difficult to convert it into hay. To prevent its being consolidated in the cocks, it must be frequently opened up, and when the weather permits, completely exposed to the sun and wind; this sort of grass being only capable of sustaining a very moderate degree of fermentation.

5805. *When the natural herbage is of a coarser description,* it may be put into small cocks, in rather a green or damp state, so as to go through the progress of "a sweating," or slight fermentation. The woody fibres in coarse hay are thus rendered more palatable and nutritious, while its condition for becoming fodder is considerably improved: but when any warmth becomes perceptible, if the weather will permit, the hay should be spread out, and put into large cocks, the moment it is in a dried state.

5806. *In the moister pastoral districts,* in the north-west parts of Scotland, hay-barns, it is thought by some, would be advantageous; the construction should be as open as possible, for the purpose of drying, as well as of preserving the hay. In some of these districts, a curious device has been fallen upon, of making the dried hay into ropes of two fathoms in length, and then twisted twofold. Being thus compressed, less room is required in the barn; and in this shape it is carried, with greater facility, to distant glens, for the use of cattle during stormy weather.

5807. *In making florin hay* (if hay it may be called, which is never dried) it is merely cut and put into small cocks, from which it is commonly taken as wanted. When it is to be put into larger cocks, it must be proportionally better dried. The stolones of this grass being remarkably vivacious, cannot easily be so dried as to admit of stacking in large bodies.

5808. *The salting of hay,* at the time of stacking, has been practised in Derbyshire and in the North Riding of Yorkshire. The salt, particularly when applied to the crop of rouen, or when the first crop has received much rain, checks the fermentation, and prevents moulding. If straw is mixed with the hay, the heating of the stack is still further prevented, by the straw imbibing the moisture. Cattle will eat, not only such salted hay but even the straw mixed with it, more eagerly than better hay not salted, and

will also thrive as well upon it. The quantity recommended is, a peck of salt to a ton of hay. By this application, hay that had been flooded was preferred by cattle to the best hay that had not been salted.

5809. *To make hay-tea.* Boil at the rate of a handful of hay to three gallons of water, or, if the water be poured boiling hot on the hay, it will answer nearly as well. Give it to the cattle and horses to drink when cold; or if the cattle and horses are anywise ill, and under cover, give it to them blood-warm. This drink is so extremely nutritive, that it nourishes the cattle astonishingly, replenishes the udders of the cow with a prodigious quantity of milk, makes the horse stale plentifully, and keeps him healthy and strong; and by this method one truss or hundred of hay will go as far as eight or ten would otherwise do. The cattle and horses do not seem to like it at first; but if they are kept till very thirsty, they will drink freely of it ever afterwards. The hay, after being used as before mentioned and dried, may be used as litter for horses and cattle; it will make very good manure, and save straw, which is a considerable advantage, especially where there is a scarcity of that article. (*Davis's Rep. of Wilts.*)

5810. *The after-grass on all meadows* is generally fed off; on firm lands, and in the dry season, by either sheep or heavy cattle; but in the winter only by sheep, unless the soil is so dry as not to be injured by the feet of cows or horses. The feet of the latter are much less injurious than those of the former; but their bite being closer is more apt to tear up the plants, than the bite of the horned tribe.

5811. *Cattle are generally removed* from meadow-lands in Middlesex in November; horses in the month following, and sheep allowed to remain till February. In Lincolnshire, Leicestershire, and on many river-meadows, every description of stock is allowed to remain till April, and sheep till May. In some districts, the whole of the after-growth is preserved from every species of stock till the following May, when it is fed off with sheep: but this greatly retards the hay crop for that year. It is evident that a good deal must depend on the farmer's other resources for keep for his stock.

5812. *The after-grass, where manure is very abundant,* is sometimes mown and made into hay or rouen, a soft and not very nutritive food, given to cows or sheep; but this is reckoned a bad practice, even in the neighbourhood of London, where manure may be had in abundance. It is also the usage of some to leave the after-grass on the ground without being eaten till spring, when it is said to be preferable, for ewes and lambs, to turnips, cabbages, or any other species whatever of what is termed spring-feed. This mode of management, which is strongly recommended by Young, and in some cases by Marshal also, is unknown in the north; where, though it is, in many instances, found beneficial, with a view to an early spring growth, not to eat the pasture too close before winter, it would be attended with a much greater loss of herbage, than any advantage in spring could compensate, to leave the after-growth of mown grounds untouched till that season.

5813. *A system of alternate mowing and feeding* is practised on some hay lands, partly to save labour and manure, and partly to subdue mosses and coarse grasses. On some soils even rich grass lands, when annually mown, become subject to weeds; for it tends to encourage moss, and gives advantage to the stronger-rooted grasses, which gradually change, and deteriorate the nature and quality of the herbage. The bottom becomes thin, the white clover disappears, and coarser plants occupy the ground. When this takes place, the pasture should be fed, instead of being mown, for the space of two or three years, until the weeds have been subdued, and the finer grasses re-appear.

5814. *By adopting the plan of mowing and feeding alternately,* a farmer, it is said, may go on longer without the application of manure, but his fields, in the end, will be ruined by it. It is contended, that to maintain a proper quantity of stock, the land must be accustomed to keep it, particularly in the case of sheep: that where land has been used to the scythe, if manured for pastures, it will often produce more grass; but that grass will not (*cæteris paribus*) support so much stock, nor fatten them nearly so well; and that old pasture will not produce so much hay as land that has been constantly mowed; for each will grow best as it has been accustomed to grow, and will not readily alter its former habits. On the other hand, it is asserted, that many experienced farmers prefer the system of feeding and mowing alternately, as they find that, under that system, the quality and quantity of the hay have been improved; and the pasturage, in the alternate year, has been equally sweet and productive.

SECT. II. *Permanent Pastures.*

5815. *Permanent pastures* may be divided into two kinds: rich or feeding lands; and hilly or rearing pastures. Under the former, we may comprehend all old rich pastures capable of fattening cattle; and under the second, such as are only adapted to rearing them, or are more advantageously depastured with sheep.

SUBSECT. 1. *Rich or feeding Pastures.*

5816. *Feeding pastures* may include such as are equally fit for hay-lands, or for being converted to arable husbandry; their characteristic being, that they are used for feeding stock, and keeping working animals and milch cows in good condition. We mentioned in a former chapter, that pasturage for one year, or for two, or more, is frequently interposed in the course of cropping arable land, to prevent that exhaustion of the soil which is commonly the consequence of incessant tillage crops. The same culture and management recommended here for rich grass lands are equally applicable to them; there being no difference, except that the latter are generally considered less suitable than rich old turf for fattening heavy stock, such as large oxen.

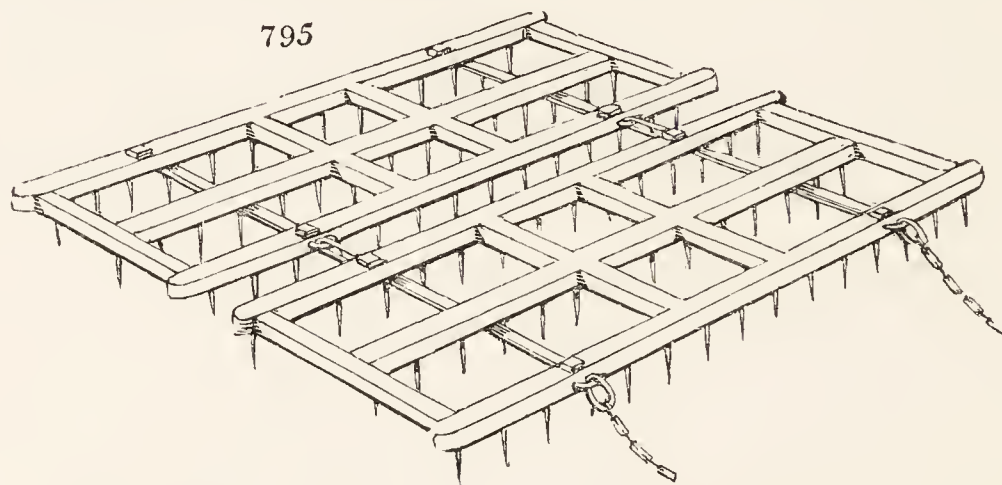
5817. *The culture and management of feeding pastures,* whether of a few years, or of perpetual duration, may be considered in regard to those necessary operations already noticed under the former section: such as the extirpation of weeds and noxious shrubs, clearing away ant and mole-hills, the application of manure, the time of stocking, the number of the animals and whether all should be of one or of different species, &c., the extent of the enclosures, and the propriety of eating the herbage close or leaving it always in a rather abundant state; all these are questions which it is scarcely possible to decide in a satisfactory manner, by the application of general rules. They can only be solved,

with any pretensions to utility, by a reference to the particular circumstances of each case; for the practice of one district, in regard to these and other points, will be found quite inapplicable to others where the soil and climate, and the purposes to which the pastures are applied, are materially different.

5818. *The weeding of pastures* should be regularly attended to. Weeds in pastures injure the farmer by the ground they occupy, the seeds they disperse, and sometimes, by influencing the quality of milk, or the health of the cattle.

5819. *On the large scale of a farm* small creeping weeds cannot be removed: but large perennial plants, such as the dock, fern, nettle; and biennials, such as the thistle, and ragweed; together with rushes and coarse tufts or tussocks of tall oat-grass, should never be permitted to shoot up into flower. The dock ought to be taken out by the root with the dock-weeder, and the others cut over with spadlets or spuds. Nettles may be mown over, as may some other weeds, and some descriptions of rushes; fern is most effectually killed by bruising or twisting asunder the stem, when the frond or herb is nearly fully expanded. Smaller weeds may be mown, and this operation should never be deferred later than the appearance of the flowers. Where the sloe-thorn forms part of the enclosure hedges, or the English elm, hoary poplar, and some other trees, grow in or around the field, they are apt to send up suckers; these should be pulled up, otherwise they will soon become a serious nuisance. In some parts of England, especially in the central districts, the hedge wastes, from the spread of the sloe-thorn and creeping rose (*Rosa arvensis*), are sometimes six or ten yards in width.

5820. *To prevent the growth of mosses* is one of the greatest difficulties in the management of old pasture land; by these the finer species of grasses are apt to be overwhelmed, and the coarse sorts only remain. Drainage, and the use of rich composts, are in this case necessary. Harrowing and cross harrowing with a common harrow, or with what are called grass harrows (*fig. 795.*), which go from one to two inches



deep, with a sprinkling of grass-seeds afterwards, and some lime or well prepared compost, are the most likely means of destroying the moss, and improving the pasture. Feeding sheep with oil-cake, and allowing them to pasture on the land, has also been found effectual for the destruction of moss, and bringing up abundance of grass. But the radical remedy is to plough up such grass lands upon the first appearance of moss, or before it has made any considerable progress, and sow them with corn.

5821. *The removal of ant and mole hills* should be attended to during the whole summer. The manner of destroying ants has already been described; mole-hills spread on grass lands may be considered as of service rather than otherwise. These operations, together with weeding, and spreading the manure dropped by the larger stock, should go on together at intervals during the whole summer.

5822. *The application of manures* to grazing lands, which not being used as hay grounds afford no means of supply, may certainly be considered a preposterous practice, and one that must be ruinous to the other parts of a farm.

5823. *In the Code of Agriculture* it is nevertheless stated, that "to keep grass in good condition, a dressing of from thirty to forty cubic yards or cart-loads of compost is required every four years. The application of unmixed putrescent manure will thus be rendered unnecessary, which ought at least to be avoided, in meadows appropriated for the feeding of dairy cows, from its affecting the quality of the milk." (p. 476.) Grass lands kept at an expense of this kind will seldom, it is believed, be found to remunerate a farmer sufficiently. The same thing is recommended (probably from inadvertence or mere following the track of preceding writers) in *Dickson's Practical Agriculture*, vol. ii. p. 953. But, except the dung dropped by the pasturing animals, which should always be regularly spread from time to time, it may be laid down as a rule of pretty extensive application, that if grass lands do not preserve their fertility under pasturage, it would be much better to bring them under tillage for a time, than to enrich them at the expense of land carrying crops of corn. (*Sup. &c. art. Agr.*)

5824. *Teathing* or stacking on the field, or carrying to be consumed there during winter, the provender that ought to have furnished disposable manure for the use of the farm at large, is another practice not less objectionable. It is to no purpose that such a wasteful practice is defended on dry light soils, which are alleged to be thus benefited by the treading of the cattle. (*Marshal's Rural Economy of Yorkshire*, vol. ii. p. 131.) During the frequent and heavy falls of rain and snow in winter, there is scarcely any land so dry as not to be injured by the treading of heavy cattle; and were there any thing gained in this respect by this management, it would be much more than counterbalanced by the loss of a great part of the manure, from the same cause. The able writer to whom we have just now referred very properly disapproves of carting on manure in winter; and for the same reason, namely, the loss of it, which must necessarily be the consequence, he ought to have objected to foddering on the land, or teathing at that season. The practice, however, is but too common in those districts, both in South and North Britain, where the knowledge of correct husbandry has made but little progress. It is equally objectionable, whether the fodder is consumed on meadows where it grew, or on other grass lands. The fodder should, in almost every instance, be eaten in houses or fold-yards, instead of the dung being dropped irregularly over the surface; or, as must be generally the case, accumulated in some spots sheltered by trees and hedges, to which the animals necessarily resort during the storms of winter.

5825. *The time of stocking pastures* in spring must evidently be earlier or later, according to the climate, and in the same climate according to the season; and the state of

growth, which it is desirable that the grass should attain before being stocked, must in some degree be determined by the condition and description of the animals to be employed in consuming it; whether they are only in a growing state or approaching to fatness; whether milch cows or sheep, or a mixture of animals of different species. It conveys no very precise idea respecting these points, though the remark itself is just, to say that the herbage should not be allowed to rise so high as to permit the coarser plants to run to seed; and that it is bad management to suffer store stock to be turned upon a full bite. (*Marshal's Yorkshire*, vol. ii. p. 129.)

5826. *The great objects to be aimed at* are, that the stock, of whatever animals it may consist, should be carried forward faster or slower, according to the purposes of their owner; and that no part of the herbage should be allowed to run to waste, or be unprofitably consumed. But nothing but careful inspection of the land and of the stock, from time to time, can enable any grazier to judge with certainty what are the best measures for attaining these objects. "Fattening cattle," says Marshal, "which are forward in flesh, and are intended to be finished with grass, may require a full bite at first turning out; but for cows, working oxen, and rearing cattle, and lean cattle intended to be fattened on grass, a full bite at the first turning out is not requisite. Old Lady-day to the middle of April, according to the progress of spring, appears to me, at present, as the best time for shutting up mowing grounds and opening pastures." (*Marshal's Yorkshire*, vol. ii. pp. 152, 153.)

5827. *In regard to the state of the growth of pastures when first stocked*, some distinction should be made between new leys and old close swards. To prevent the destruction of the young plants, whether of clover or other herbage, on the former description of pasture, which would be the consequence of stocking them too early, especially with sheep, they should be allowed to rise higher than would be necessary in the case of old turf; and to secure their roots from the further injury of a hot summer, it is advisable not to feed them close in the early part of the season, and probably not at any time throughout the whole of the first or second season, if the land is to be continued in pasture. The roots of old and firm sward, on the other hand, are not in so much danger, either from close feeding or from the heats of summer; and they are in much less danger from the frosts and thaws of winter.

5828. *With regard to the stock which should be employed*, all soils rather moist and of such a quality, as is the case with rich clays, as to produce herbage suited to the fattening of cattle, will, in general, be more advantageously stocked with them than with sheep: but there can be no other rule for the total exclusion of sheep, than the danger of the rot; nor any other general rule for preferring one kind of stock to another, than their comparative profits. (*Sup. art. Agr.*)

5829. *Whether the stock should be all of one or of different kinds* is another question to be discussed.

5830. *With regard to a mixed stock*, the sentiments and practice of the best graziers seem to be in its favour. "It is generally understood that horses and cattle intermixed will eat grass cleaner than any species will alone, not so much from their separately affecting different grasses, as from the circumstance of both species disliking to feed near their own dung." (*Marshal's Yorkshire*, vol. ii. p. 154.) "Some few graziers follow the old custom of keeping only one kind of stock upon the same ground, whilst others, we think, with more propriety, intermix with oxen and cows a few sheep, and two or three colts in each pasture, which both turn to good account, and do little injury to the grazing cattle. In some cases sheep are a real benefit, by eating down and destroying the ragwort (*Senecio Jacobæa*), which disgraces some of the best pastures of the county, where oxen only are grazed." (*Northumberland Report*, p. 126.) In Lincolnshire, where grazing is followed to a great extent, and with uncommon success, as well as in most other districts, the practice seems to be almost invariably, to keep a mixed stock of sheep and cattle on the same pasture (*Lincolnshire Report*, p. 174.), in proportion varying with the nature of the soil and the quality of the herbage.

5831. *To estimate the number of animals that may be depastured on any given extent of ground* is obviously impossible, without reference to the particular spot in question; and the same difference exists with regard to the propriety of feeding close, or leaving the pastures rough, that prevails in most other parts of this subject. Though there is loss in stocking too sparingly, the more common and dangerous error is in overstocking, by which the summer's grass is not unfrequently entirely lost. On rich pasture lands in the neighbourhood of Banbury, in Oxfordshire, one ox and two sheep are calculated as stock sufficient for one acre.

5832. *With respect to the size of enclosures*, small fields are much to be preferred to large ones, for heavy stock.

5833. *Besides the advantages of shelter*, both to the animals and the herbage, small fields enable the grazier either to separate his stock into small parcels, by which means they feed more at their ease, or to give the best pastures to that portion of them which he wishes to come earliest to market. The advantages of moderate-sized enclosures are well known in the best grazing counties; but the subdivisions are in some instances much more minute than is consistent with the value of the ground occupied with fences, or necessary to the improvement of the stock. In all cases, says Marshal, where fattening cattle or dairy cows make a part of the stock, and where situation, soil, and water will permit, every suit of grazing grounds ought, in my idea, to consist of three compartments: one for head stock, as cows or fattening cattle; one for followers, as rearing and other lean stock; and the third to be shut up to freshen for the leading stock. (*Marshal's Yorkshire*, vol. ii. p. 158.)

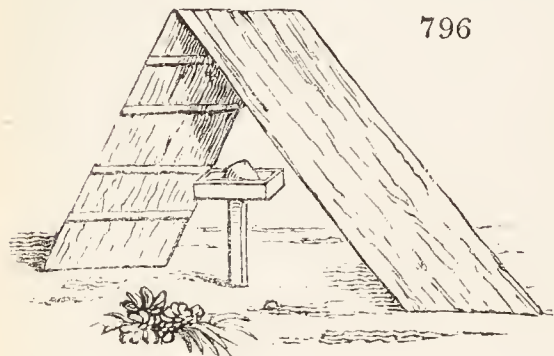
5834. *Large enclosures* are in general best adapted for sheep. These animals are not only impatient of heat and liable to be much injured by flies, in small pastures often surrounded by trees and high hedges, but they are naturally, with the exception perhaps of the Leicester variety, much more restless and easily disturbed than the other species of live stock. "Sheep," says Lord Kaimes, "love a wider range, and ought to have it; because they delight in short grass: give them eighty or ninety acres, and any fence will keep them in; confine them to a field of seven or eight acres, and it must be a very strong fence that keeps them in." (*Gentleman Farmer*, p. 203.) Though fields so large as eighty or ninety acres can be advisable only in hilly districts, yet the general rule is nevertheless consistent with experience, in regard to all our least domesticated varieties.

5835. *With respect to the propriety of eating the herbage close, or leaving it rather in an abundant state*, an eminent agriculturist observes, that there seems to be a season, some time during the year, when grass lands, particularly old turf, should be eaten very close.

not merely for the sake of preventing waste, but also for the purpose of keeping down the coarser kinds of plants, and giving to the pastures as equal and fine a sward as possible.

5836. *The most proper period* must partly depend upon the convenience of the grazier; but it can hardly be either immediately before the drought of summer or the frost of winter. Some time in autumn, when the ardent heat of the season is over, and when there is still time for a new growth before winter, may be most suitable for the land itself, and generally also for the grazier, his fat stock being then mostly disposed of, or carried to the after-grass of mown grounds. The sweeping of pastures with the scythe may be employed as a substitute for this close feeding; the waste and labour of which, however, though but trifling, it does not seem necessary to incur on rich grazing lands, under correct management. (*Sup. E. Brit. art. Agr.*)

5837. *Fogging pasture lands* is a practice which is sometimes adopted in districts where there is a scarcity of winter food. Under that system, fields in pasture are shut up early in May, and continued in that state till November or December, when the farmer's stock is turned in, and continue to pasture till the May succeeding. Such management, however, can only be advisable on a soil of the driest nature, which will not be injured by poaching in the wettest seasons. It is practised in a few places in Cardiganshire; but is considered by the late Thos. Johnes, Esq., of Hafod, as the result of necessity, the farmers not being able to bring sufficient stock to eat it down in season, when its nutritive powers are in their best state.



5838. *Water* should be provided for every field under pasture; and also shelter and shade, either by a few trees, or by a portable shed, which may be moved with the stock from one enclosure to another. Where there are no trees, rubbing posts are also found a desirable addition. In Germany they have portable sheds which are employed both in summer and winter, and generally with a piece of rock-salt fixed to a post for the cattle to suck at. (*fig. 796.*)

SUBJECT. 2. *Hilly and Mountainous Pastures.*

5839. *Hilly pastures* include such low hills as produce fine short herbage, and are with much advantage kept constantly in pasture, though they are not altogether inaccessible to the plough; as well as such tracts as, from their acclivity and elevation, must necessarily be exclusively appropriated to live stock. The former description of grass lands, though different from the feeding pastures, of which we have just treated, in respect to their being less convenient for tillage management, are nevertheless in other circumstances so nearly similar, as not to require any separate discussion. These low hills are for the most part occupied with sheep, a very few cattle being sometimes pastured towards their bases; and they frequently comprise herbage sufficiently rich for fattening sheep, together with coarser pastures for breeding and rearing them.

5840. *In regard to the management of upland pastures*, of the rules which judicious farmers practise, the following deserve to be selected:—

5841. *To enclose those pastures*, as the same extent of land, when sheltered, and properly treated, will feed a greater quantity of stock, and to better purpose, than when in an open and exposed state. Not to overstock upland pastures; for when this is done, the cattle are not only starved, and the quantity of herbage diminished, but the soil is impoverished. When the pasture ground is enclosed and subdivided, so as to admit of it, the stock ought to be shifted from one enclosure to another, at proper intervals; giving the first of the grass to the fattening, in preference to the rearing, stock. This practice tends to increase the quantity of grass, which has thus time to get up; and the ground being fresh and untainted, when the stock returns to it, more especially if rain has fallen, they will feed with greater appetite and relish. The dung dropped by the stock, while feeding, should be spread about, instead of being suffered to remain where it was deposited, in a solid body. Where the larger and the smaller kinds of stock are to be fed on the same pastures, the larger species should have the first bite; and it is not thought by some advisable to depasture land with a mixed collection of different species of live stock, unless the field is extensive, or unless the herbage varies in different parts of the field. It is generally found, that the grass produced by the dung of cattle or horses is injurious to sheep, producing grass of too rich a quality for that species of stock. There is no mode by which such pastures are more effectually improved, than by the application of lime, either spread upon the surface or mixed with the soil. In the latter case, it is essential that the lime should be mixed with the surface soil only; as lime is apt to sink, if covered deeply by the plough. The coarse grasses would, in that case, regain possession of the soil, and the dung afterwards deposited by the cattle will not enrich the land in the same manner as if the lime had been incorporated with the surface only. (*Code.*)

5842. *Mountainous pastures*, from which the plough is altogether excluded, have been commonly classed among waste lands; even such of them as bear herbage by no means of inconsiderable value; as well as heaths and moors with patches of which the green pastures are often chequered. The general term wastes is therefore a very indefinite expression; and, indeed, is not unfrequently made to comprehend all that extensive division of our territory that neither produces corn nor rich herbage. Yet it is on such tracts that by far the greater part of our butcher's meat and wool is grown, and not a little of the former fully prepared for the market. Foreigners and superficial readers at home must accordingly be greatly mistaken, if they imagine that what are called *wastes* by the Board of Agriculture, and other writers on rural economy, are really altogether unproductive; and it would be a still grosser error to believe that all those wastes owe their continuance to neglect or mismanagement; and that any exertions of human industry can ever render the greater part of them, including all the mountainous tract of Great Britain, more valuable than they are at present, without a much greater

expenditure of capital than, under almost any circumstances, they could possibly return—*(Sup. art. Agr.)*

5843. *Menteath of Closeburn*, in Dumfriesshire, has regenerated old pasture by paring up the turf with a paring plough or spade, laying it to one side for a week or two, and again replacing it where it was before, after the subsoil had been stirred by ploughing and harrowing, and a little lime, ashes, or other manure added. A field so treated was found, in four years, to keep fifteen head of cattle fully better than it did ten in its former state. The improvement is considered to give of annual profit one third of the prime cost, so that in little more than four years it will clear itself. *(Gard. Mag. vol. vi.)*

5844. *Improving pasture without taking a crop of corn.* The same gentleman having had a considerable extent of the poorest moorland in Scotland in his estate of Closeburn, Dumfriesshire, entertained the opinion that it might pay for improving the pasture without taking a crop of corn from this poor soil, which in general was a peat earth upon a gravel or sand or red freestone, and which he considered too poor to produce a remunerating crop of corn. He accordingly set to work to improve about a thousand acres of this poor soil from four hundred to eight hundred feet above the sea, and sometimes pared and burned nearly two hundred acres in one summer, which he ploughed in the autumn and allowed to lie in that state till the next spring, when he laid on about one hundred and seventy bushels of quicklime, or lime shells, as they are there called from their shelling or falling to pieces when watered, per English acre, and in the month of July harrowed in between five and six bushels of *Hólcus lanátus* grass seed. The greatest part of this land has now been improved about twenty years, and is continuing to yield abundance of grass, and is worth from 12s. to 14s. per acre, while in its natural state it was scarcely worth 2s.; and Mr. M. is convinced it would pay amply for another dressing of lime, which a Scotch farmer, he says, would not think of, as the plough is upon all occasions the implement in most active operation with him. In the improvement of moor ground, Mr. M. thinks it highly important to state that the very worst effects result from pulverising or bringing the peaty or vegetable soil to a complete state of putrefaction or pulverisation, before being laid down to pasture; and that this must certainly take place when two or three corn crops are taken before sowing out. Moory peaty soil after this treatment is liable to be poached in wet weather, and in dry weather is almost equally incoherent, and is difficult to be again restored without dung or great quantities of earth. *(C. G. Stuart Menteath, March 1830, in Gard. Mag. vol. vi.)*

5845. *The chief improvements of which mountainous pastures are susceptible* are, draining and sheltering by plantations. Some parts might probably be enclosed by strips of plantation between stone walls, or by stone walls alone; but as the stock on mountain pastures are generally under the care of a herdsman, the advantages of change of pasture and alternate eating down and saving or sparing the grass, by keeping out the cattle, are obtainable without the use of fields.

SECT. III. *Improvement of Grass Lands, by a temporary Conversion to Tillage.*

5846. *The practice of breaking up grass lands*, either with a view to their being soon after restored, or to their permanent retention in aration, has occasioned much discussion, and even attracted the attention of the Legislature, and the Board of Agriculture. In *The Code of Agriculture* it is stated, that a “much larger proportion of the united kingdom, than is at present so cultivated, might be subjected to the alternate system of husbandry, or transferred from grass to tillage, and then restored to grass.” Much of the middling sorts of grass lands, from 200 to 400 feet above the level of the sea, is of this description; and many husbandmen, and most indiscriminate friends of the corn laws and the lauded monopoly, regret that such lands are left in a state of unproductive pasture, and excluded from tillage. Were the trade in corn free, the idea of tilling such lands would be at least problematical.

5847. *A very extensive enquiry* was made, in consequence of a requisition from the House of Lords to the Board of Agriculture, in December 1800, “into the best means of converting certain portions of grass lands into tillage, without exhausting the soil, and of returning the same to grass, after a certain period, in an improved state, or at least without injury;” and the information collected by the Board, upon that subject, is in the highest degree satisfactory and important.

5848. *On this subject the opinion of one of our first writers* is, “that though it is impossible to deny that much grass land in England would be more productive, both to the proprietor and occupier, under a good course of cropping, than under pasture; yet it is no less certain, that there are large tracts of rich grazing land, which, in the present state of the demand for the produce of grass lands, and of the law of England, with regard to tithes, cannot be employed more profitably for the parties concerned, than in pasture. The interest which the Board of Agriculture has taken in this question, with a view to an abundant supply of corn for the wants of a rapidly increasing population, seems, therefore, not to have been well directed. Instead of devoting a large portion of their volumes to the instruction of farmers, regarding the best method of bringing grass lands into tillage, and restoring them again to meadow or pasture, without deterioration; the first thing required was, to attempt removing the almost insuperable obstruction of tithes, by proposing to the legislature an equitable plan of commutation. If some beneficial arrangement were adopted on this head, there is no reason to doubt, that individual interest would soon operate the wished-for change; and that all grass lands capable of yielding more rent and profit under tillage than under pasture would be subjected to the plough, as fast as the demands of the population might require. *(Sup. E. B. art. Agr.)*

5849. *In giving the essence of the information collected by the Board*, we shall first state the opinions as to such grass lands as should not be broken up, and next the directions for breaking up and laying down the others.

SUBJECT 1. *Grass Lands that ought not to be broken up by the Plough.*

5850. *There are various sorts of grass lands that ought not to be broken up*; as water meadows; salt marshes; lands apt to be overflowed; lands near large populous towns, where the produce of grass land is always in demand, and consequently dear; and low-lying tracts, in the valleys of mountainous countries, particularly in chalky districts, where old meadow land is scarce, and where a portion of it, to raise early and late food for stock, gives a great additional value to the adjoining upland. But whether rich lands, which have long remained in grass, and continue productive, should ever be converted into tillage, is a question respecting which a great diversity of opinion has been entertained.

5851. *The lands considered as best adapted for permanent pasture* are of three kinds: strong tenacious clays, unfit for turnips or barley, which are said to improve the more the longer they are kept under a judicious system in grass; soft clayey loams, with a clayey or marly bottom or substratum; and rich, sound, deep-soiled land, or vale land, enriched by nature at the expense of the higher grounds, generally lying in a situation favourable with respect to climate.

5852. *The advantages of such pastures* are represented in the strongest light. It is affirmed, that they feed cattle to a greater weight; that they are not so easily scorched by the summer's drought; that the grasses are more nutritive, both for sheep and cattle; that milch cows fed upon them give richer milk, and more butter and cheese; that the hoofs of all animals pastured on them are much better preserved; that they produce a greater variety of grasses; that, when properly laid down, they yield a succession of pasture throughout the whole season; that the herbage is sweeter, and more easily digested; and that they return an immense produce at a trifling expense.

5853. *To break up lands possessing these advantages*, it is said, can only be justified by the most urgent public necessity, and to prevent the horrors of famine. The real value of such lands will appear by considering their rent and produce. The grass lands in Lincolnshire are accounted the richest in the kingdom. The rents are various; from 1*l.* 15*s.* to 3*l.* per acre; and the value of the produce from 3*l.* per acre to 10*l.* This produce arises from beef, mutton, and wool; and is obtained subject to little variation from the nature of the seasons, and at a trifling expense. The stock maintained per acre on the best grazing lands surpasses what could be fed by any arable produce. It is not at all uncommon to feed at the rate of from six to seven sheep in summer, and about two sheep in winter. The sheep, when put on the grass, may weigh from 18 lbs. to 20 lbs. per quarter, and the increase of weight would be at the rate of 4 lbs. per quarter, or 16 lbs. per sheep. But suppose in all only 100 lbs. at 8*d.* per pound, that would amount to 3*l.* 17*s.* 10*d.* The wool would be worth about two guineas more, besides the value of the winter keep; and the total may be stated at about 7*l.* per acre, got at little expense. Such lands, it is evident, cannot be better employed than in feeding stock.

5854. *Grass land on tenacious clays and heavy loams*, when brought in a succession of years, or perhaps of ages, into a state of great productiveness, cannot be ploughed without the risk of great injury, and are more profitable in the production of herbage than they could be in the production of grain.

5855. *Grass on deep-soiled sound vale lands* would be productive of corn if ploughed; but would be probably injured by cultivation: from their texture being altered, and rendered unduly loose and open by tillage; from the native plants being more or less destroyed or enfeebled; and from the great decomposition and waste of the principles of fertility resident in the soil.

5856. *The extent of these descriptions of land*, however, is not so great that the advantages of breaking them up could probably ever be a national object, or worth the risk of injuring their future productiveness in grass. But there are pasture lands of an inferior sort, which are too apt to be confounded with those already described; and respecting the propriety of occasionally appropriating them to arable culture, there can hardly be a doubt. Such lands do not depend upon their intrinsic fertility, but upon annual supplies of manure derived from the arable land in their neighbourhood.

SUBJECT. 2. *Advantages and Disadvantages of breaking up Grass Lands.*

5857. *The advantages of breaking up grass lands*, not of the richest quality, will appear by a comparison of their produce with that of arable lands.

5858. *From the enquiry of the Board of Agriculture*, it appears that an acre of clover, tares, rape, potatoes, turnips, cole, or cabbages, will furnish at least thrice as much food as the same acre would have done, had it remained in pasture of a medium quality; and, consequently, that the same extent of land would maintain at least as much stock as when in grass, besides producing every other year a valuable crop of corn; and this, independently of the value of the straw, which, whether consumed as litter, or as food for cattle, will add considerably to the stock of manure. It follows that, with the exception of rich pastures, arable land is, on an average, superior to grass land, with respect to furnishing articles of human food, in the proportion of three to one; and consequently every piece of land unnecessarily kept in grass, the produce of which will only maintain one person, is depriving the community of food capable of maintaining two additional members.

5859. *The principal objection to the conversion of old turf into arable land* arises from an alleged inferiority, both in bulk and nutritive properties, in the new when compared to the old herbage. It is certain, that by no art can we at once produce a surface of grasses which can be at all compared to some of the richest pastures in Buckinghamshire, Lincolnshire, and Leicestershire; but these are not the pastures which any prudent agriculturist would recommend to be broken up, whatever might be the price of corn; and more especially in Britain, and with a prospect of the trade in corn being at no distant period free. Still, in by far the greater number of cases where the soil will admit of the convertible husbandry, and where that husbandry is as well understood and practised as it is in the north of England and south of Scotland, we should have no hesitation in leaving it to the farmer to break up whatever pastures he thought he could do with profit during a fourteen or twenty-one years' lease. A gentleman who had a large farm, principally consisting of strong rich clay (every field of which, with hardly any exception, he occasionally broke up), was accustomed to lay them down with a crop of barley, and to sow fourteen pounds of white clover, a peck of rib-grass, and three quarters of hay seeds, per acre. By this liberal allowance of seed, he always secured a thick coat of herbage the first year, which differed from old pasture in being more luxuriant. Such lands, therefore, under judicious management, will rarely be injured by the plough. When laid down from tillage into grass, they may not carry for the first year or two such heavy cattle as they would afterwards; but they will support more in number, though of a smaller size, and bring a greater weight of butcher meat to market. It is often desirable to keep one or two moderate-sized enclosures, of from ten to twenty acres, according to the size of the farm, in perennial pasture, for the feeding of cattle and sheep, and as a resource for the stock to go to in case of a severe spring or summer drought; but the retaining of any considerable portion of a farm in old turf, or permanent pasture, unless of the richest quality, is in general injurious to the landlord, the tenant, and the public. The value of any estate, where the system of permanent pasture has been carried to an unreasonable extent, may be easily and greatly augmented by appropriating the manure of the farm to turnips and other green crops, and by the adoption of the convertible system of husbandry."

5860. *There are many cases where this doctrine, though in general to be recommended, ought not to be carried to its full extent.* In Norfolk, where the land is commonly light, and where the sheep are both bred and fed upon the same farm, a proportion of permanent pasture is essential. Much injury, in particular, has been sustained by breaking up permanent pastures on such soils, more especially when subject to rectorial tithes. Many lands of an inferior soil, which kept two sheep on an acre, paying only vicarial tithes, and rented at ten shillings per acre, since they have been broken up cannot pay, even without rent, the tithes of corn and the expense of cultivation. A farm in general lets best with a fair proportion of grass land upon it, which admits of a mixed management; in consequence of which, if one object fails another may be successful.

5861. *With respect to the disadvantages of breaking up pastures, it is alleged in The Code of Agriculture, that there is a risk of tenants breaking through their engagements (p. 473. 3d edit.); by which we suppose is to be understood, the chance of their taking a few good crops from the newly broke-up lands, and then leaving the farm. Tenants who would do this must certainly be as wicked as the landlords who would put in their power would be imbecile. No other disadvantage is stated, and this may safely be left to work its own cure.*

SUBJECT. 3. *Breaking up Grass Lands, and afterwards restoring them to Grass.*

5862. *On the subject of breaking up and laying down grass lands, the following particulars are discussed in the Code of Agriculture, as the result of the information communicated to the Board: — Whether any previous steps are necessary before lands in grass are broken up? the proper mode of effecting that object; the course of crops; the manure necessary; the system of management during the rotation; the mode of laying down the land again to grass; that of sowing the grass-seeds; and the subsequent management.*

5863. *If the land be wet, it is advisable to drain it completely, previously to its being broken up; for it is not improbable that its being kept in pasture was partly on account of its wetness.*

5864. *Land that has been long in pasture does not require dung during the first course of crops that is taken after being broken up; but the application of calcareous manure is always, in such cases, expedient. Sometimes lime is spread on the ground before it is ploughed; at other times when it is either under summer-fallow, or a drilled crop of turnips. Marl and chalk also have been used for the same purpose with great advantage. The land thence derives additional strength and vigour; the succeeding crops are much improved; the soil is commonly so softened in its texture, that it may be ploughed with half the strength that would otherwise be necessary; and whenever it is restored to grass, the herbage is abundant.*

5865. *Wherever the soil is not too shallow, nor of a friable nature, or when the turf cannot soon be rotted, if land is to be broken up from old pasture, the system of paring and burning is proper. In this way, good tilth is speedily procured; the damage that might otherwise be sustained by the grub, the wire-worm, and other insects, is avoided, while the soil receives a stimulus which ensures an abundant crop.*

5866. *Where paring and burning cannot take place, the land may be trenched or double-ploughed. This is effected by means of two ploughs following each other, the first plough taking off a thin surface of about three inches, and the second going deeper in the same place, covering the surface-sod with fine mould; both furrows not exceeding the thickness of the vegetable mould or other good soil. If the land is ploughed with one furrow, the operation ought to be performed before winter, that it may receive the benefit of the succeeding frosts, by which the success of the future operations will not only be promoted, but most of the insects lodged in the soil will be destroyed. When one furrow alone is taken, the best size is four inches and a half deep by eight or nine broad. The strain on horses in ploughing ley land is mostly from the depth.*

5867. *The rotation of crops to be adopted, when grass lands are broken up, must partly depend upon the soil, and partly on the manner in which it is prepared for cultivation. As a general principle, however, it may be laid down, that unless by the course of cropping to be pursued the bad grasses and other plants indigenous to the soil are extirpated, they will, when the land is again laid down to grass, increase and prevail with more rapidity and effect than seeds chosen by the farmer; and the consequence must be, a heavy disappointment in the future crops of grass, perhaps solely, or at least principally, attributable to a previous defective management. It is necessary, therefore, to enter into details upon this subject as applicable to clay, chalk, peat, loam, and sand.*

5868. *Clay.* The process of conversion in clayey soils should be commenced with paring and burning, especially where the grub is suspected. The following course may then be adopted: — 1. Rape, fed with sheep; 2. beans; 3. wheat; 4. beans; 5. wheat; 6. fallow; 7. wheat, sown with grass-seeds. This may seem severe cropping, but it is justified by experience when old grass clay-land is broken up. If the land has not been pared and burnt, the first crop ought to be either oats or dibbled beans. To do justice to the plan of restoring the land to grass, there ought to be, in all cases, according to the soil, either a naked or turnip fallow, before the sowing of grass-seeds is attempted. But on mellow loamy clay land, consisting of fine old grass pasture, where it is thought necessary or advisable to break up such land, it should be done in detached pieces, so as to suit the convenience of the occupier, and the following course should be adopted: — 1. Autumnal ploughing for oats in spring; 2. fallow for rape, to be eaten with sheep; 3. beans; 4. wheat, sown with clover; 5. clover; 6. clover; 7. wheat; 8. rape, to be partially eaten, and hoed in spring, and to stand for seed; and 9. wheat with grass-seeds. This is a very profitable rotation, and applicable to the best grazing land in Lincolnshire.

5869. *Chalk.* Paring and burning are considered in this case to be indispensable as a preparation for turnips, which ought, where manure can be got, to be raised two years in succession; then, barley, clover, wheat; and, after one or two additional crops of turnips, the land may be laid down with saintfoin to great advantage.

5870. *Peat.* On this soil paring and burning are essentially necessary. Under a judicious system, the greatest and quickest profit is thus secured to the farmer, with advantage to the public, and without injury to the landlord. Draining also must not be neglected. The crops to be grown on peat soils are, 1. rape or potatoes; 2. oats; 3. turnips; 4. oats or wheat; and 5. clover or grass-seeds. A liberal application

of lime, where it can be obtained, is of the greatest service in enabling such soils to bring corn to its full perfection. In the fens of Thorney, the following course was recommended:—1. Paring and burning for rape; 2. oats; and 3. wheat with grass-seeds; if the land were safe from water, the Lammas sort, if not, spring wheat. This short course, it is contended, preserves the land in heart; and it afterwards produces abundant crops of grass. But long courses, in such a soil, run the lands to weeds and straw, without quality in the grain.

5871. *Loam.* The courses of crops applicable to this soil are too numerous to be here inserted. If the sward is friable, the following rotation may be adopted:—1. Oats; 2. turnips; 3. wheat or barley; 4. beans; 5. wheat; 6. fallow or turnips; 7. wheat or barley, and grass-seeds. If the sward is very tough and coarse, instead of taking oats, it may be pared and burnt for turnips.

5872. *Sand.* On rich and deep sandy soils, the most valuable that can be raised is a crop of carrots. For inferior sands, turnips, to be eaten on the ground; which should then be laid down with barley and grass-seeds.

5873. *According to the improved system of laying down lands to grass,* land ought to be previously made as clean and fertile as possible. With that view, all the green crops raised ought to be consumed upon the ground; fallow or fallow crops ought not to be neglected; and the whole straw of the corn crops should be converted into manure, and applied to the soil that produced it. Above all, the mixing of calcareous matter with the soil, either previously to, or during the course of, cropping, is essential. Nothing generally improves meadows or pastures more than lime or marl: they sweeten the herbage, render it more palatable to stock, and give it more nourishing properties.

5874. *When turnips are raised upon light land,* sheep should be folded on them; whereas, if the land is strong or wet, the crop should be drawn, and fed in some adjoining grass-field, or in sheds. If the land is in high condition, it is customary to cart off half the turnips, and eat the other on the ground. But this is not a plan to be recommended on poor soils.

5875. *It has been disputed whether grass-seeds should be sown with or without corn.* In favour of the first practice, that of uniting the two crops, it is maintained, that where equal pains are taken, the future crop of grass will succeed as well as if they had been sown separately, while the same tilth answers for both. On the other hand, it is observed, that as the land must, in that case, be put into the best possible order, there is a risk that the corn-crop will grow so luxuriantly as to overpower the grass-seeds, and, at any rate, will exclude them from the benefit of the air and the dews. If the season also be wet, a corn crop is apt to lodge, and the grass will, in a great measure, be destroyed. On soils moderately fertile, the grasses have a better chance of succeeding; but then, it is said, that the land is so much exhausted by producing the corn-crops, that it seldom proves good grass land afterwards. In answer to these objections, it has been urged, that where, from the richness of the soil, there is any risk of sowing a full crop of corn, less seed is used, even as low as one third of the usual quantity; and that a moderate crop of grain nurses the young plants of grass, and protects them from the rays of a hot sun, without producing any material injury. Where the two crops are united, barley is the preferable grain, except on peat. Barley has a tendency to loosen the texture of the ground in which it grows, which is favourable to the vegetation of grass-seeds. In the choice of barley, that sort should be preferred which runs least to straw, and which is the soonest ripe. On peat, a crop of oats is to be preferred. The most recent practice of the best farmers is in favour of sowing the grass-seeds without the addition of corn, or any other temporary plant.

5876. *The manner of sowing the grass-seeds* also requires to be particularly attended to. Machines have been invented for that purpose, which answer well, but they are unfortunately too expensive for the generality of farmers. It is a bad system, to mix seeds of different plants before sowing them, in order to have the fewer casts. It is better, to sow each sort separately; for the expense of going several times over the ground is nothing, compared to the benefit of having each sort equally distributed. The seeds of grasses being so light, ought never to be sown in a windy day, except by machinery, an equal delivery being a point of great consequence. Wet weather ought likewise to be avoided, as the least degree of poaching is injurious. Grass seeds ought to be well harrowed, according to the nature of the soil.

5877. *When the corn is carried off, the young crop of grass should be but little fed during autumn,* and that only in dry weather; but heavily rolled in the following spring, in order to press the soil home to the roots. It is then to be treated as permanent pasture. By attention to these particulars, the far greater proportion of the meadows and pastures in the kingdom, of an inferior, or even medium quality, may be broken up, not only with safety, but with great profit to all concerned.

CHAP. VIII.

Plants cultivated on a limited Scale for various Arts and Manufactures.

5878. The plants used as food for men and animals are by far the most generally cultivated in every country; and, next, *those of clothing, building, and other arts of convenience or luxury.* The former are often called agricultural, and the latter commercial or manufatorial plants. Of manufatorial plants, only a few are at present cultivated in Britain; the national policy rendering it preferable to import them, or substitutes, from other countries. Some, however, are still grown in nearly sufficient quantities for home consumption, as the hop, mustard, rape, and a considerable quantity of flax, anise, and carraway; some hemp, teasle, and woad are also raised. These and other plants may be classed as grown for the clothing, distilling, brewing, oil-making, and domestic and medical arts.

SECT. I. *Plants grown chiefly for the Clothing Arts.*

5879. *The clothing plants* are flax, hemp, teasle, madder, woad, and weld; the first three are used by the manufacturer of the fabric, and the others by the dyer.

SUBJECT. 1. *Flax*. — *Linum usitatissimum* L.; *Pentándria Pentagýnia* L., and *Línea* Dec. *Lin*, Fr.; *Flacks*, Ger.; and *Lino*, Ital. and Span. (fig. 797. a.)

5880. *The flax* has been cultivated from the earliest ages, and for an unknown length of time in Britain, of which it is now considered a naturalised inhabitant. It is cultivated both for its fibre for making thread, and its seed for being crushed for oil; but never has been grown in sufficient quantity for either purpose. The legislature of the country, as Brown observes, has paid more attention to framing laws regarding the husbandry of flax than to any other branch of rural economy; but it need not excite surprise that these laws, even though accompanied by premiums, have failed to induce men to act in a manner contrary to their own interest. The fact is, the culture of flax is found on the whole less profitable than the culture of corn. It is one of the most severe crops when allowed to ripen its seed; but by no means so when pulled green.



5881. *The varieties of the common flax* are few, and scarcely deserving of notice. Marshal mentions the blue or lead-coloured flax as being

cultivated in Yorkshire, and Professor Thaer mentions a finer and coarser variety; he also, as well as some other agriculturists, has tried the *Linum perenne* (b), but though it affords a strong fibre, it is coarse and difficult to separate from the woody matter.

5882. *The soils most proper for flax*, besides the alluvial kinds, are deep and friable loams, and such as contain a large proportion of vegetable matter in their composition. Strong clays do not answer well, nor soils of a gravelly or dry sandy nature. But whatever is the kind of soil, it ought neither to be in too poor nor in too rich a condition: because, in the latter case, the flax is apt to grow too luxuriantly, and to produce a coarse sort; and, in the former case, the plant, from growing weakly, affords only a small produce. (*Tr. on Rural Affairs.*)

5883. *If there is water at a small depth below the surface of the ground*, it is thought by some still better; as in Zealand, which is remarkable for the fineness of its flax, and where the soil is deep and rather stiff, with water almost every where, at the depth of a foot and a half or two feet. It is said to be owing to the want of this advantage, that the other provinces of Holland do not succeed equally well in the culture of this useful plant; not but that fine flax is also raised on high lands, if they have been well tilled and manured, and if the seasons are not very dry. It is remarked, in the letters of the Dublin Agricultural Society, that moist stiff soils yield much larger quantities of flax, and far better seed, than can be obtained from light lands; and that the seed secured from the former may, with proper care, be rendered full as good as any that is imported from Riga or Zealand. M. Du Hamel, however, thinks that strong land can hardly yield such fine flax as lighter ground.

5884. *The place of flax in a rotation of crops* is various, but in general it is considered as a corn or exhausting crop, when the seed is allowed to ripen; and as a green, or pea, or bean crop, when the plant is pulled green.

5885. *Flax, Donaldson observes*, is sown after all sorts of crops, but is found to succeed best on lands lately broken up from grass. In Scotland, the most skilful cultivators of flax generally prefer lands from which one crop of grain only has been taken, after having been several years in pasture. When such lands have been limed or marled, immediately before being laid down to grass, the crop of flax seldom or never misgives, unless the season prove remarkably adverse. In the north of Ireland flax is generally sown by the small farmers after potatoes. In Belgium, it is supposed not to do well after peas or beans; nor to succeed if sown oftener on the same soil than twice in nine years. (*Von Thaer.*)

5886. *The preparation of the soil*, when grass land is intended for flax, consists in breaking it up as early in the season as possible, so that the soil may be duly mellowed by the winter frosts, and in good order for being reduced by the harrows, when the seed process is attempted. If flax is to succeed a corn crop, the like care is required to procure the aid of frost, without which the surface cannot be rendered fine enough for receiving the seed. Less frost, however, will do in the latter than in the former case; therefore, the grass land ought always to be earliest ploughed. At seed-time, harrow the land well before the seed is distributed, then cover the seed to a sufficient depth, by giving a close double harrowing with the harrows. Water-furrow the land, and remove any stones and roots that may remain on the surface, which finishes the seed process.

5887. *The ordinary season of sowing flax-seed* is from the middle of March to the middle or end of April, but the last week of March and the first ten days of April are esteemed the best time; and accordingly within these periods the greatest quantity of flax-seed is sown in this country. In France and Italy it is often sown in the autumn, by which a larger crop is produced, especially when seed is desired.

5888. *The quantity of seed* depends on the intention of the crop. When a crop of seed is intended to be taken, thin sowing is preferable, in order that the plants may have room to throw out lateral shoots, and to obtain air in the blossoming and filling seasons.

But it is a mistake to sow thin when flax is intended to be taken; for the crop then becomes coarse, and often unproductive. From eight to ten pecks per acre is the proper quantity in the last case, but when seed is the object, six pecks will do very well. (*Brown.*) Thick-sown flax runs up in height, and produces fine soft flax; if sown thin, it does not rise so high, but spreads more and puts forth many side branches, which produce abundance of seed, and such seed is much better filled, plumper and heavier, than the seed produced from thick-sown flax. (*Donaldson.*)

5889. *In the choice of seed*, that which is of a bright brownish colour, oily to the feel, and at the same time weighty, is considered the best.

5890. *Linseed, imported from various countries*, is employed. That brought from Holland is, however, in the highest estimation; as it not only ripens sooner than any other that is imported, but also produces greater crops, and flax of that quality which best suits the chief manufactures of the country. American seed produces, in common, fine flax; but neither the quantity of flax nor of the pods, provincially the "bolls," which contain the seeds, is so large as the produce from Dutch linseed. Riga seed yields a very coarse sort of flax, but a greater quantity of seeds than any other. It is common in some parts of Scotland to sow seeds saved from the crop of the preceding year, especially when that crop was raised from seed imported from Holland. The success of this practice is found to depend greatly on changing the seed from one sort of soil to another of an opposite nature; but the saving in the expense of purchasing that sort of seed, in place of what is newly imported from Holland, is so inconsiderable, and the risk of the crop misgiving so much greater in the one case than in the other, that those only who are ignorant of the consequences, or who are compelled from necessity, are chargeable with this act of ill-judged parsimony. Flax-seed is by some farmers changed every three years, but many have sown the same seed ten years in succession without perceiving any degeneracy. When any degeneracy takes place, the seed of flax grown on a different soil, as moss, moor, sand, &c. without any view to the produce in fibre, will, it is said, answer as well as foreign seed.

5891. *The manner of sowing* is almost always the same; but when seed is the main object, drilling may be adopted, by which seed will be saved in sowing, cleaning conducted at less expense, and the plants rendered more vigorous and branchy by the stirring of the soil and the admission of air between the rows. The fibres of flax grown in this way, however, will be shorter, and less equal in thickness throughout their length, than flax grown by the broad-cast mode, and tolerably thick.

5892. *The after-culture of flax* consists chiefly in weeding, but sometimes it commences with rolling the surface, which is a very proper operation when the soil is very dry, the season advanced, or the earth very porous. By this process the earth is pressed firmly to the seeds, and they are thereby stimulated to vegetate sooner, and the drought is kept out. On some soils, and in wet or stormy seasons, flax is apt to be laid, to guard against which some cultivators run across their flax field slender poles fixed to stakes: but a better method is to run small ropes across the field, both lengthwise and breadthwise, where necessary; for these being fastened where they intersect one another, and supported by stakes at due distances, form a kind of network, which is proof against almost every accident that can happen from tempestuous weather.

5893. *In Scotland* a crop of flax, it is said, has been sometimes weeded by turning a flock of sheep at large into the field. They will not taste the young flax plants, but they carefully search for the weeds, which they devour.

5894. *The flax crop is taken by pulling*, on which there is a considerable difference of opinion. None, however, think of pulling it before it comes into flower, when fibre is the sole object; or before the seed in the capsules acquires a brownish colour, when fibre and seed jointly are required, or when seed alone is the object.

5895. *Some argue for it pulling while green*, in order that its fibres may be softer and finer; others, with the same view, pull it up before its seeds are quite formed; and others again think that it should not be pulled till some of the capsules which contain the seeds have begun to open, being of opinion that the fibres of green flax are too tender, and that they fall into tow. On the other hand, it is certain the fibres of flax which has stood till it is very ripe are always stiff and harsh, that they are not easily separated from the reed, and that they do not bleach well. Here, therefore, as in most other cases, both extremes should be avoided; and it consequently seems most reasonable to think that the properest time for pulling flax, is when its stalks begin to turn from a green to a yellow, when its leaves begin to fall, and when its seeds begin to be brown. Donaldson observes, that a crop of flax frequently grows short, and runs out a great number of seed-bearing branches. When that is the case, the seeds, not the flax, ought to be the farmer's chief object, and the crop should be allowed to stand till the seeds are in a great measure perfected. But that when the crop thrives, and is likely to become more valuable for the flax than the seeds, it should be pulled soon after the bloom drops off, and before the pods turn hard and sharp in the points. When flax is grown for its fibre, Brown considers it the safest course to take it a little early, any thing wanting in quantity being, in this way, made up by the superiority of quality.

5896. *The operation of pulling flax* differs according to the intention of the crop. When it is grown for the fibre it is pulled and tied into sheaves like corn, and carried off immediately to be watered. But when the seed is to be taken from the plant, it is pulled and laid in handfuls.

5897. *In pulling flax*, it is usual, when it is intended to save the seeds, to lay it in handfuls, partly across each other; the reason for which is, that the business of rippling is thereby facilitated, as the rippers, in place of having to separate each handful from the bundle, find it by this simple precaution already done to their hand. Although it is of much importance, yet it very seldom happens that much attention is bestowed to separate the different sorts of flax from each other, in pulling the crop. In most fields, there are varieties of soils; of course some parts of a field will produce fine flax, others coarse; some long, and some short: in a word, crops of different lengths and qualities. It cannot be supposed that all these sorts of flax will undergo an equal degree of watering, grassing, breaking, and heckling, without sustaining great injury.

5898. *As the flax is pulled*, it is laid together by handfuls, with the seed end turned to the south. These handfuls should

neither lie quite in a line with each other, nor directly across, but a little slanting upwards, so that the air may easily pass through them. Some, instead of this method, tie the handfuls of flax loosely at the top, then spread out their roots, and thus set several of them together upright upon their roots. In either of these ways, the flax is generally left twelve or fourteen days in the field to dry it. This drying is certainly not necessary for the rippling, because the ripple will separate the capsules from the flax as effectually before it has been dried as it will afterwards; and if it is done with a view to ripen the seed, it should be considered, that the flax will be more hurt by the longer time of steeping, which will become necessary in consequence of this drying, than the seed can be benefited; because, the more the membrane which connects the fibres to the reed is dried, the greater must be the degree of putrefaction necessary to loosen and destroy the cohesion of this connecting membrane; the finer parts of the flax itself must necessarily be

destroyed by this degree of putrefaction; and if the putrefaction does not arise to such a degree as to destroy the cohesion of this membrane, the fibres of the flax will adhere so strongly to the reed, that the force necessary in scutching will prove

equally detrimental to the flax. The practice adopted in some parts of Britany seems therefore much more rational, which is, to ripple the flax after it has lain in the air two or three days; but even one day will be sufficient, if the weather is dry.

5899. *In the process of rippling*, which is the next operation, a large cloth should be spread on a convenient spot of ground, with the ripple placed in the middle of it.

5900. *In performing this business*, the pods containing the seeds are forced from the stalks by means of the iron comb called a ripple, fixed on a beam of wood, on the ends of which two persons sit, who, by pulling the seed end of the flax repeatedly through this comb, execute the operation in a very complete manner. It is remarked by the author of *The Present State of Husbandry in Great Britain*, that "those who bestow much attention on the cultivation of flax in Scotland generally ripple off the seed, even when there is no intention of saving it; as it is found, when flax is put into water without taking off the pods, the water soon becomes putrid, in consequence of which the flax is greatly injured."

5901. *The management of the capsules, and the separation of the seed*, form the next operation.

5902. *The capsules obtained should be spread in the sun to dry*, and those which separate from the pods of their own accord, being the fullest and ripest, should be set apart for sowing, in case the precaution of raising some flax purposely for seed has not been attended to. The capsules are then broken, either by treading or by threshing, in order to get out the remaining seeds, the whole of which, as well as the others, should be carefully sifted, winnowed, and cleaned. When the seed is laid up, it must be frequently stirred, or ventilated, to prevent its heating. Even this second seed affords a considerable profit, by the oil which it yields, and also by being used when broken for fattening of cattle.

5903. *To facilitate the separation of the fibre from the bark*, it is necessary to accelerate the process of decay or putrefaction. This may be done in different ways; but the chief are bleaching alone, and steeping and bleaching.

5904. *Bleaching is a tedious and laborious operation* when it is intended as a substitute for steeping, but it is less likely to injure the fibre, and may be adopted on a small scale when steeping places are not at hand. In Dorsetshire, and some other places, flax, instead of being steeped, is what is called dew-retted; that is, the stalks are allowed to arrive at that state in which the harl or woody parts separate most easily from the boon, reed, or fibre, by a more gradual process, that of ripening by the action and influence of the dew. This is nothing more than exposing the flax to the influence of the weather for a longer period than is necessary, when the operation of watering has been previously performed. Steeping, however, is the most universal practice both in Britain and on the Continent.

5905. *Steeping or watering*, however, is and will be the general practice till flax-dressing machines come into universal use. In performing this operation, the flax, whether it has been dried and rippled, or pulled green, is loosely tied into small bundles, the smaller the better, because it is then most equally watered; and these bundles are built in the pool in a reclining upright posture, so that the weight placed above may keep the whole firmly down. The weights made use of are commonly stones placed on planks, or directly on the flax.

5906. *The Flemish mode of steeping flax*, as described by Radcliff, is said to improve the quality of the flax; and greatly increase its whiteness. This mode differs from the common practice, in placing the bundles in the steep vertically, instead of horizontally; in immersing the flax by means of transverse sticks, with that degree of weight annexed which shall not push it down to the bottom, but leave it the power to descend spontaneously towards the conclusion of the steepage; and in leaving at first a space of at least half a foot between the bottom and the roots of the flax. The spontaneous descent of the flax is an indication of its being sufficiently steeped; and the strength and quality of the fibre are said to be much better preserved by this mode, in which the temperature of the atmosphere acts with most force on the upper part of the plant, which needs it most.

5907. *The water most proper for steeping flax* should be clear, soft, and in standing pools. Compared with running water, pools occasion the flax to have a better colour, to be sooner ready for the grass, and even to be of superior quality in every respect. When soft, clear, stagnating water cannot be obtained without art, a pit or canal is commonly formed, adjoining to a river or stream, whence water can be easily brought. This pit or canal is filled with water for some time (a week or two) before it is proposed to pull the flax; by this means the water acquires a greater degree of warmth than river-water possesses, which contributes greatly to facilitate the object farmers have in view in immersing green flax in water, namely, to make the harl or flaxy substance part easily and completely from the boon or reed.

5908. *The period that flax ought to remain in the water*, depends on various circumstances; as the state of ripeness in which it was pulled, the quality and temperature of the water, &c. The most certain rule by which to judge when flax is sufficiently watered is, when the boon becomes brittle, and the harl separates easily from it. In warm weather, ten days of the watering process are sufficient; but it is proper to examine the pools regularly after the seventh day, lest the flax should putrefy or rot, which sometimes happens in very warm weather. Twelve days will answer in any sort of weather; though it may be remarked, that it is better to give too little of the water, than too much, as any deficiency may be easily made up by suffering it to lie longer on the grass, whereas an excess of water admits of no remedy. (*Brown.*)

5909. *Grassing or bleaching flax* is the next operation, the intention of which is to rectify any defect in the watering process, and carry on the putrefactive process to that point when the fibre will separate from the bark, boon, reed, or harl (as the woody part of the stem is called), with the greatest ease. In performing this operation, the flax is spread very thin on the ground, and in regular rows; the one being made to overlap the other a few inches, with a view of preventing, as much as possible, its being torn up and scattered by gales of wind. Old grass-ground, where the herbage does not grow to any great height, is the best for the purpose; as when the flax is covered by the grass or weeds, it is frequently rotted, or at least greatly injured thereby.

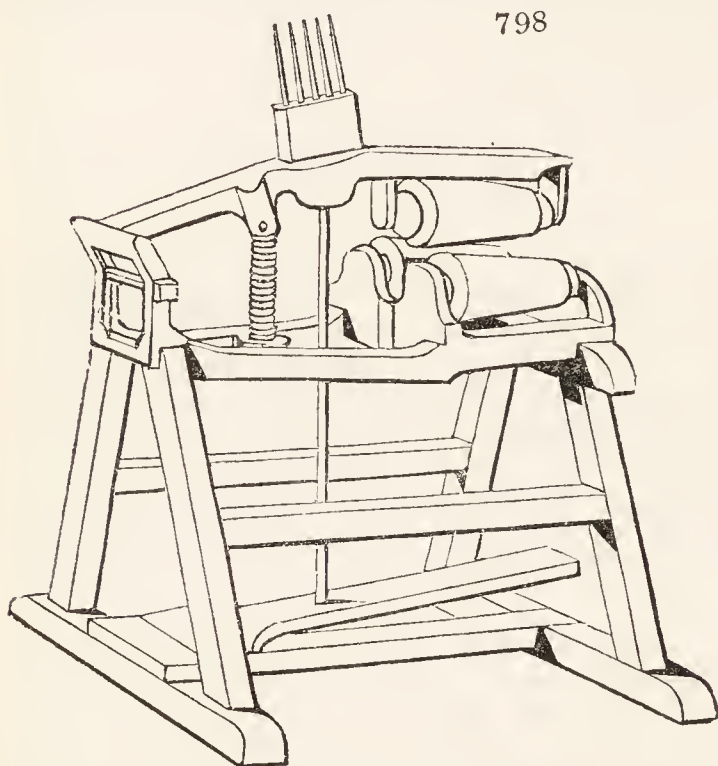
5910. *The time allowed for grassing* is regulated by the state of the flax, and seldom exceeds ten or twelve days. During this time it is repeatedly examined; and when it is found that the boon has become very brittle, so that, on being broken, and rubbed between the hands, it easily and freely parts from the harl, it is taken up, a dry day being chosen for the purpose, and, being bound in sheaves, is either sent directly to the mill, which is the usual practice in the northern districts, or broken and scutched by a machine or implement for the purpose.

5911. *Steeping flax in hot water and soft soap* (said to be the invention of Lee, and for which he was granted by parliament a secret or unenrolled patent) is said to separate the fibre from the woody matter better than steeping in water simply; and this in the short space of two or three hours, and either with green flax, or such as has been dried and stacked for months or years. When flax is to be separated by this new mode, the cultivator has only to pull it in handfuls, dry it, bind it into sheaves or faggots, and put it up in stacks like corn, till wanted by the manufacturer.

5912. *The dressing of flax* consists of various operations, such as scutching, tracking,

or breaking, by which the woody part is broken ; and heckling or combing, by which the fibre is separated from the woody part, and sorted into lengths. These operations are often all performed by the cottager, or small farmer, who grows flax for the purpose of spinning the fibre in his own family. But there are also public flax mills, impelled by water or other powers, by which flax is scutched, and it is then heckled by professed hecklers.

5913. *A method of preparing flax in such a manner as to resemble cotton in whiteness and softness*, as well as in coherence, is given in *The Swedish Transactions* for the year 1747. For this purpose a little sea-water is to be put into an iron pot or an untinned copper kettle, and a mixture of equal parts of birch-ashes and quicklime strewed upon it ; a small bundle of flax is to be opened and spread upon the surface, and covered with more of the mixture, and the stratification continued till the vessel is sufficiently filled. The whole is then to be boiled with sea-water for ten hours, fresh quantities of water being occasionally supplied in proportion to the evaporation, that the matter may never become dry. The boiled flax is to be immediately washed in the sea by a little at a time, in a basket, with a smooth stick at first, while hot ; and when grown cold enough to be borne by the hands, it must be well rubbed, washed with soap, laid to bleach, and turned and watered every day. Repetitions of the washing with soap expedite the bleaching ; after which the flax is to be beat, and again well washed ; when dry, it is to be worked and



carded in the same manner as common cotton, and pressed betwixt two boards for forty-eight hours. It is now fully prepared and fit for use. It loses in this process nearly half its weight, which, however, is abundantly compensated by the improvement made in its quality.

5914. *Lee's method of breaking flax and hemp, without dew-retting*, was invented in 1810, and was the first step towards a great improvement, brought nearer perfection by the new patent machines of Messrs. Hill and Bundy.

5915. *Hill and Bundy's machines* (fig. 789.) are portable, and may be worked in barns or any kind of out-house ; they are also well calculated for parish workhouses and charitable institutions ; a great part of the work being so light that it may be done by children and infirm persons ; and such is the construction and simplicity of the machines, that no previous instruction or practice is required ; their introduction, therefore, into those asylums would be the means of effecting a considerable reduction of the poor's rate. The woody part is removed by a very simple machine ; and, by passing through a machine equally simple, the flax may be brought to any degree of fineness, equal to the best used in France and the Netherlands, for the finest lace and cambric. The original length of the fibre, as well as its

strength, remains unimpaired ; and the difference of the produce is immense, being nearly two thirds ; one ton of flax being produced from four tons of stem. The expense of working each ton obtained by this method is only five pounds. The glutinous matter may be removed by soap and water only, which will bring the flax to such perfect whiteness, that no further bleaching is necessary, even after the linen is woven ; and the whole process of preparing flax may be completed in six days.

5916. *The produce of flax in seed* is generally from six to eight, sometimes as high as ten or twelve, bushels per acre ; and the price depends in a great measure on that of foreign seed imported ; as, when sold to oil-makers, it is generally about one half of that of Dutch seed sold for the purpose of sowing.

5917. *The price of home-cultivated linseed* is considerably advanced of late in some of the southern and western counties of the kingdom, in proportion to what it is in the northern, owing to the circumstance of its being much used as food for fattening cattle. The average price of the linseed cultivated in the kingdom at large cannot, it is supposed, be rated higher than from three to four shillings the bushel. The seed is separated into three qualities ; the best for sowing, the second best for crushing for oil, and the inferior for boiling or steaming for cattle.

5918. *The produce of flax in fibre* varies exceedingly. Before being sorted, the gross product of fibre varies from three cwt. to half a ton per acre.

5919. *The use of flax* in the linen manufacture is well known. The seed is crushed for oil, which is that in common use by painters ; the cake or husk, which remains after the expression of the oil, is sold for fattening cattle, and in some places as a manure ; and the inferior seed, not fit to crush, is boiled and made into flax-seed jelly, which is esteemed excellent nutriment for stock.

5920. *As the making of flax-seed jelly* is an agricultural operation, we shall here describe it. The proportion of water to seed is about seven to one. The seed having been steeped in part of the water for eight-and-forty hours previously to the boiling, the remainder of the water is added cold, and the whole boiled gently about two hours, being kept in motion during the operation, to prevent its burning to the boiler. Thus the whole is reduced to a jelly-like, or rather a gluey or ropy, consistence. After being cooled in tubs, it is given, with a mixture of barley-meal, bran, and cut chaff ; a bullock being allowed about two quarts of the jelly per day, or somewhat more than one quart of seed in four days : that is, about one sixteenth of the medium allowance of oil-cake.

5921. *The diseases of flax* are few, and are chiefly the fly, which sometimes attacks the plants when young, the midew, and the rust.

SUBJECT. 2. *Hemp*. — *Cánnabis sativa* L.; *Diœ'cia Pentándria* L., and *Urtíceæ* J. *Chanvre*, Fr.; *Hanf*, Ger.; *Canapa*, Ital.; and *Canomo*, Span.

5922. *The hemp* is a plant of equal antiquity with the flax. It is supposed to be a native of India, or of some other Asiatic country, being too tender to be even naturalised in Europe. It is one of the few plants employed in British agriculture in which the male and female flowers are in different plants, a circumstance which has some influence on its culture and management. It grows to a great height on good soils; sometimes to six or seven feet in this country, but in Italy generally higher; and Crud states, that in the Bolognese territory he has seen it fifteen feet eight inches high, and a friend of his eighteen feet six inches: in both cases the fibre being of remarkable beauty. This luxuriance of the hemp in warm countries may be one reason why it has never been much cultivated in England. In the Isle of Axholme, in Lincolnshire, it has been cultivated from time immemorial, and also for some centuries in Suffolk, but chiefly for local manufacture. The culture, management, and uses of hemp are nearly the same as those of flax. When grown for seed, it is a very exhausting crop; but when pulled green, it is considered a cleaner of the ground, and is said to have the property of preserving from insects any crop which it may surround. The objections to this crop are, that its coming in the midst of harvest is embarrassing; and that the attention it demands in every state of its progress is too great, where it is only a secondary consideration.

5923. *The soils* most suitable for hemp are those of the deep black putrid vegetable kind, which have a situation low and somewhat inclined to moisture, as well as the deep mellow loamy or sandy sorts. But the quantity of produce is in general much greater on the former than the latter; though, according to some, of an inferior quality. Mellow rich clayey loams do well; and nothing better than old meadow land.

5924. *The preparation of the soil*, and the place in the rotation, are the same as for flax.

5925. *The season of sowing* is towards the end of April, when there is no longer any danger of frost injuring the rising plants. The quantity of seed is from two to three bushels, according to the quality of the land. In quality the seed must be fresh, heavy, and bright in colour. Broad-cast is the universal mode of sowing; and the only after-culture consists in keeping off birds when it is coming up; in weeding; and sometimes in supporting the crop by cross rods or lines, as in the case of flax.

5926. *In taking the hemp crop*, two methods are in use, according to the object in view. When the crop is grown entirely for the fibre, it is pulled when in flower, and no distinction made between the male and female plants. But as it is most commonly grown both with a view to fibre and seed, the usual practice is to pull the male plants as soon as the setting of the seed in the females shows that they have effected their purpose. As the female plants require four or five weeks to ripen their seeds, the males are thus pulled so long before them.

5927. *In the operation of pulling the males*, the pullers walk in the furrows between the ridges, and reach across to the crown of the ridge, pulling one or two stalks at a time, and carefully avoiding to tread down the female plants. The male stalks are easily known by their yellowish hue and faded flowers. They are tied in small bundles, and immediately carried to the watering pool, in the manner of flax.

5928. *The operation of pulling the females* commences when the seed is ripe, which is known by the brownish or greyish hue of the capsules and the fading of the leaves. The stalks are then pulled and bound up into bundles, being set up in the same manner as grain, until the seed becomes so dry and firm as to shed freely; great care should be taken in pulling not to shake the stalks rashly, otherwise much of the seed may be lost. It is advised that, after pulling the seed, hemp may be set to stand in shocks of five sheaves, to dry the seed; but, in order to prevent any delay in watering, the seed-pods may be cut off with a chopping-knife, and dried on canvass exposed to the air under some shed or cover. This last method of drying the seed will prove of great advantage to the hemp, as the seed and pods, when green, are of such a gummy nature that the stems might suffer much by sun-burning or rain, which will discolour and injure the hemp before the seed can be sufficiently dried upon the stalks. Besides, the threshing out the seed would damage the hemp in a considerable degree.

5929. *Hemp is watered* (provin. water-retted), *bleached* (provin. dew-retted), and *grassed* in the same manner as flax. Grassing is omitted in some places, and drying substituted; and in other districts watering is omitted with the female crop, which is dried and stacked, and dewed or bleached the following spring. On the Continent hot water and green soap have been tried; and here, as in the case of flax, it is found that steeping for two hours in this mixture is as effectual in separating the fibre from the woody matter, as watering and grassing for weeks.

5930. *Although hemp, in the process of manufacturing*, passes through the hands of the breaker, heckler, spinner, whitester, weaver, and bleacher, yet many of these operations are frequently carried on by the same person. Some weavers bleach their own yarn and cloth; others their cloth only: some heckle their tow, and put it out to spinning; others buy the tow, and put it out; and some carry on the whole of the trade themselves.

5931. *The produce of hemp in fibre* varies from three to six cwt. per acre; in seed from eleven to twelve bushels.

5932. *The uses of hemp* are well known, as well as its great importance to the navy for sails and cordage.

5933. *Exceedingly good huckaback* is made from it, for towels and common table cloths. The low priced hempen cloths are a general wear for husbandmen, servants, and labouring manufacturers; the better sorts for working farmers and tradesmen in the country; and the finer ones, seven-eighths wide, are pro-

ferred by some gentlemen for strength and warmth. They possess this advantage over Irish and other linens, that their colour improves in wearing, while that of linen declines. English hemp, properly manufactured, stands unrivalled in its strength, and is superior in this respect to the Russian. Considerable quantities of cloth are imported from Russia for sheeting, merely on account of its strength; for it is coarser at the price than linen: our hempen cloth, however, is preferable; being stronger, from the superior quality of the thread, and at the same time lighter in washing. The hemp raised in England is not of so dry and spongy a nature as what we have from Russia and India, and therefore it requires a smaller proportion of tar to manufacture it into cordage. Tar being cheaper than hemp, the rope-makers prefer foreign hemp to ours; because they can make a greater profit in working it: but cordage must certainly be stronger in proportion as there is more hemp and less tar in it, provided there is a sufficient quantity of the latter to unite the fibres. An oil extracted from the seeds of hemp is used in cookery in Russia, and by painters in this country. The seeds themselves are reckoned a good food for poultry, and are supposed to occasion hens to lay a greater quantity of eggs. Small birds in general are very fond of them; but they should be given to caged birds with caution, and mixed with other seeds. A very singular effect is recorded, on very good authority, to have been sometimes produced by feeding bullfinches and goldfinches on hempseed alone, or in too great quantity, — that of changing the red and yellow on those birds to a total blackness.

5934. *The hemp* has few or no diseases.

SUBJECT. 3. *The Fuller's Thistle, or Teasel.* — *Dipsacus fullonum* L.; *Tetrandria Monogynia* L., and *Dipsacæ* J. *Chardon à foulon*, Fr.; *Kardendistel*, Ger.; *Dissaco*, Ital.; and *Cardencha*, Span. (fig. 799.)

5935. *The fuller's thistle* is an herbaceous biennial, growing from four to six feet high; prickly or rough in the stem and leaves, and terminated by rough burr-like heads of flowers. It is a native of Britain, flowers in July, and ripens its seed in September. It is cultivated in Essex and the west of England, for raising the nap upon woollen cloths by means of the crooked awns or chaffs upon the heads; which, in the wild sort, are said to be less hooked. For this purpose they are fixed round the circumference of a cylinder, which is made to turn round, and the cloth is held against them. In the *Journal of a Naturalist* we are informed, that the teasel forms an article of culture in cottage gardens in the clothing districts of Gloucestershire.

5936. *There are no varieties* of the cultivated teasel, and the wild species is not materially different from it, and may be used in its stead, though its chaff is not quite so rigid.

799



5937. *The soils* on which the teasel grows strongest are deep loamy clays, not over-rich. The situation should be rather elevated, airy, and exposed to the south. In a rotation it may occupy the place of a green and corn crop, as in the first year the plants are treated like turnips, and in the second the crop is ripened. The soil should be ploughed deep, and well comminuted by cross-ploughings, or stirrings with pronged implements, as the cultivator.

5938. *The sowing season* is the beginning of April: the quantity of seed is from one peck to two pecks per acre, and in quality it should be fresh and plump.

5939. *The mode of sowing* is almost always broad-cast, but no crop is better adapted for being grown in drills, as the plants require hoeing and thinning. The drills may be either sown on ridgelets or a flat surface, in the manner of turnips, or by ribbing. The distance between the rows may be from eighteen inches to two feet. In Essex, caraway is commonly sown with the teasel-crop; but this is reckoned a bad plan.

5940. *The after-culture* of this crop consists the first year in hoeing and stirring the soil, and in thinning out the plants to the distance of one foot every way, if sown broad-cast, or to the distance of six inches if sown in rows. Vacancies may be filled up by transplanting; and a separate plantation may be made with the thinnings, but these never attain the same vigour as the seedlings. The culture in the second year consists also of hoeing, stirring, and weeding, till the plants begin to shoot.

5941. *When the teasel is grown broad-cast*, the intervals between the plants are dug by means of spades which have long narrow blades, not more than about four inches in breadth, having the length of sixteen or eighteen inches. With these the land is usually worked over in the intervals of the plants three or four times during the summer months; and in the course of the following winter, as about the latter end of February, the land between the plants is to be again worked over by the narrow spades, care being taken that none of the mould falls into the hearts of the plants. Again about the middle of May, when they begin to spindle, another digging over is given, the earth being raised round the root-stems of the plants, in order to support and prevent them from being blown down by the wind. Some cultivators perform more frequent diggings, that the ground may be rendered cleaner and more mellow; consequently the growth of the plants will be the more effectually promoted. This business, in Essex, has usually the name of spaddling, and is executed with great despatch by labourers accustomed to perform it.

5942. *The taking of the teasel crop*, when no regard is had for seed, commences about the middle of July, when the blossoms begin to fall from the top, or terminating heads of flowers.

5943. *It is the best method* to have the heads cut as they become ripe; but the work is mostly executed at three times, at the distance of about ten days or a fortnight from each other. It is performed by means of a knife, contrived for the purpose, with a short blade and a string attached to the haft. This last is done in order that it may be lunged over the hand. A pair of strong gloves is likewise necessary. Thus prepared,

the labourer cuts off the ripe heads along the rows or lines with about nine inches of stem, and ties them up in handfuls with the stem of one that is more perfectly ripened. On the evening of the day on which they are cut, they should be put into a dry shed; and when the weather is fine and the air clear, they should be taken out and exposed to the sun daily till they become perfectly dry. Much care must, however, be taken that no rain falls upon them. In doing this, some make use of long small stakes or poles, on which these handfuls are hung during the time of their preparation.

5944. *As soon as they are completely dried*, they should be laid up in a dry room, in a close manner, till they become tough and of a bright colour, and ready for use. They should then be sorted or separated into three kinds, by opening each of the small bundles. These are distinguished into kings, middlings, and scrubs, according to their different qualities. They are afterwards, the author of *The Somerset Report* says, made into packs, which, of the first sort, contain nine thousand heads, but when of the second, twenty thousand; the third is a sort of very inferior value. By some, before forming them into packs, they are done up into what are termed staves, by means of split sticks, when they are ready for sale.

5945. *The produce of teasel varies from ten to fifteen packs on the acre*; nine packs of kings, nineteen of middlings, and two of scrubs, are reckoned a large crop, with a great bulk of haulm. Often, however, the crop fails.

5946. *The use of the heads of the teasel has been already mentioned*. The haulm is of no use but for burning as manure. Parkinson observes, that this is a sort of crop that may be grown to advantage on many lands, in a rotation, as a fallow to prepare for wheat; and by burning the straw and refuse stuff after the crop is reaped, it will be found not to impoverish, but rather to improve the land. In their young state, the teasel plants stand the winter without danger; and are a good crop for clearing land of all weeds, from their lateness in the process of hoeing, their being few weeds that vegetate at so advanced a season. On all these accounts they become an advantageous crop for the farmer.

5947. *To save seed*, leave a few of the very best plants uncropped, and then, when the seed is ripe, cut off only the largest and terminating heads, from which the seed is easily separated by beating with flails, and cleaned by the winnowing machine, or a sieve.

5948. *The chief injuries to which the teasel is liable* are those inflicted on it while young, by the fly and slug.

SUBJECT. 4. *Madder*.—*Rubia tinctorum* L.; *Tetrándria Monogýnia* L., and *Rubiðceæ* J. *Garance*, Fr.; *Färberröthe*, Ger.; *Robia*, Ital.; and *Rubia*, Span. (fig. 800.)

5949. *The dyer's madder has a perennial root, and an annual stalk*. The root is com-

posed of many long, thick, succulent fibres, almost as large as a man's little finger; these are joined at the top in a head, like the roots of asparagus, and strike very deep into the ground, being sometimes more than three feet in length. From the upper part (or head of the root) come out many side roots, which extend just under the surface of the ground to a great distance, whereby it propagates very fast; for these send up a great number of shoots, which, if carefully taken off in the spring soon after they are above ground, become so many plants. It is a native of the south of Europe, flowers in June, and seeds soon afterwards; but by them it is never propagated. Madder is mentioned by the Greeks as a medical plant, but when it was first used in dyeing is uncertain. It has been cultivated in Holland and Flanders, and other parts of the Continent, for the latter purpose for many centuries, and has been tried in this country; but unless the importation of the root from the Continent be entirely prevented, it will not answer. Its culture has been attempted at different times when our



commerce with the Dutch was interrupted, or when they raised the price of the article exorbitantly high. At present it may be imported not only from Holland, but from France, Italy, and Turkey.

5950. *The soils most suited to the cultivation of madder* are deep, fertile, sandy loams, not retentive of moisture, and having a considerable portion of vegetable matter in their composition. It may also be grown on the more light descriptions of soil, of sufficient depth, and in a proper state of fertility.

5951. *The preparation of the soil* may either consist in trench ploughings, lengthwise and across, with pronged stirrings, so as to bring it to a fine tilth; or, what will often be found preferable, by one trenching two feet deep by manual labour.

5952. *The sets or plants* are best obtained from the runners, or surface-roots of the old plants. These being taken up, are to be cut into lengths of from six to twelve inches, according to the scarcity or abundance of runners. Sets of one inch will grow if they have an eye or bud, and some fibres; but their progress will be injuriously slow for want of maternal nourishment. Sets may also be procured by sowing the seeds in fine light earth a year before they are wanted, and then transplanting them; or sets of an inch may be planted one year in a garden, and then removed to the field plantation.

5953. *The season of planting* is commonly May or June, and the manner is generally in rows nine or ten inches asunder, and five or six inches apart in the rows. Some plant promiscuously in beds with intervals between, out of which earth is thrown in the lazy-bed manner of growing potatoes; but this is unnecessary, as it is not the surface, but the descending, roots which are used by the dyer.

5954. *The operation of planting* is generally performed by the dibber, but some ley-plant them by the aid of the plough. By this mode the ground is ploughed over with a shallow furrow, and in the course of the operation the sets are deposited in each furrow, leaning on and pressed against the furrow-slice. This, however, is a bad mode, as there is no opportunity of firming the plants at the roots, and as some of the sets are apt to be buried, and others not sufficiently covered.

5955. *The after-culture* consists in hoeing and weeding with stirring by pronged hoes, either of the horse or hand kind. Some earth up, but this is unnecessary, and even injurious, as tearing the surface-roots.

5956. *The madder-crop is taken* at the end of the third autumn after planting, and generally in the month of October. By far the best mode is that of trenching over the ground, which not only clears it effectually, but fits it at once for another crop. Where madder, however, has been grown on land prepared by the plough, that implement may be used in removing it. Previously to trenching, the haulm may be cleared off with an old scythe, and carted to the farmery to be used as litter to spread in the straw-yards.

5957. *Drying the roots* is the next process, and, in very fine seasons, may sometimes be effected on the soil, by simply spreading the plants as they are taken up; but in most seasons they require to be dried on a kiln, like that used for malt or hops. They are dried till they become brittle, and then packed up in bags for sale to the dyer.

5958. *The produce* from the root of this plant is different according to the difference of the soil, but mostly from ten to fifteen or twenty hundred weight where they are suitable to its cultivation.

5959. *In judging of the quality of madder-roots*, the best is that which, on being broken in two, has a brightish red or purplish appearance, without any yellow cast being exhibited.

5960. *The use of madder-roots* is chiefly in dyeing and calico-printing. The haulm which accumulates on the surface of the field, in the course of three years, may be carted to the farm-yard, and fermented along with horse-dung. It has the singular property of dyeing the horns of the animals who eat it of a red colour.

5961. *Madder-seed* in abundance may be collected from the plants in the September of the second and third years; but it is never so propagated.

5962. *Madder is sometimes blighted*; but in general it has few diseases.

SUBJECT. 5. *Woad*. — *Isatis tinctoria* L.; *Tetradynamia Siliquosa* L., and *Cruciferae* J. *Pastel* or *Guède*, Fr.; *Waid*, Ger.; *Guade*, Ital.; and *Gualda*, Span. (fig. 801.)

5963. *The common woad* is a biennial plant with a fusiform fibrous root, and smooth branchy stem rising from three to five feet in height. It is a native, or naturalised in England, flowers from May to July, and its seeds are ripe from July to September. It has been cultivated in France for an unknown length of time, and was introduced to England in 1582, and grown with success. It is now chiefly cultivated in Lincolnshire, where it is a common practice to take rich flat tracts near rivers, at a high price, for the purpose of growing it for two or four years. Those who engage in this sort of culture form a sort of colony, and move from place to place as they complete their engagements. It is sometimes, however, grown by stationary farmers. The leaves are the parts of the plant used, and it is considered a severe crop.

5964. *There is a variety* of woad called the Dalmatian, described by Miller, and also a wild sort; but only the common is cultivated in this country.

5965. *The soil* for woad should be deep and perfectly fresh, such as those of the rich, mellow, loamy, and deep, vegetable kind. Where this culture is carried to a considerable degree of perfection, as in Lincolnshire, the deep,

rich, putrid, alluvial soils on the flat tracts extending upon the borders of the large rivers, are chiefly employed for the growth of this sort of crop; and it has been shown by repeated trials that it answers most perfectly when they are broken up for it immediately from a state of sward.

5966. *The preparation of the soil*, when woad is to be grown on grass land, may either be effected by deep ploughings, with the aid of the winter's frost, cross ploughing and



harrowing in spring ; by deep ploughing and harrowing in spring ; by paring and burning ; or by trench-ploughing, or spade trenching.

5967. *The first mode appears the worst*, as it is next to impossible to reduce old turf in one year, and, even if this is done, the danger from the grub and wire-worm is a sufficient argument against it. By ploughing deep in February, and soon afterwards sowing, the plants may germinate before the grub is able to rise to the surface ; by trench-ploughing, the same purpose will be better attained ; and, best of all, by spade trenching. But a method equally effectual with the first, more expeditious, and more destructive to grubs, insects, and other vermin, which are apt to feed on the plants in their early growth, is that of paring and burning. This is, however, chiefly practised where the sward is rough and abounds with rushes, sedge, and other plants of the coarse kind, but it might be had recourse to on others, with benefit.

5968. *The time of sowing* may be extended from February to July. Early sowing, however, is to be preferred, as in that case the plants come up stronger and afford more produce the first season.

5969. *The mode of sowing* is generally broad-cast, but the plant might be most advantageously grown in rows and cultivated with the horse-hoe. The rows may be nine inches or a foot apart, and the seed deposited two inches deep. The quantity of seed for the broad-cast method is five or six pounds to the acre ; for the drill mode, two pounds are more than sufficient, the seed being smaller than that of the turnip. New seed, where it can be procured, should always be sown in preference to old ; but, when of the latter kind, it should be steeped for some time before it is put into the ground.

5970. *The after-culture* of the woad consists in hoeing, thinning, prong-stirring, and weeding, which operations may be practised by hand or horse tools, as in the culture of teazle.

5971. *Gathering the crops.* The leaves of the spring-sown plants will generally be ready towards the latter end of June or beginning of July, according to the nature of the soil, season, and climate ; the leaves of those put in at a later period in the summer are often fit to be gathered earlier. This business should, however, constantly be executed as soon as the leaves are fully grown, while they retain their perfect green colour and are highly succulent ; as when they are let remain till they begin to turn pale, much of their goodness is said to be expended, and they become less in quantity, and of an inferior quality for the purposes of the dyer.

5972. *In the execution of this sort of business*, a number of baskets are usually provided in proportion to the extent of the crop, and into these the leaves are thrown as they are taken from the plants. The leaves are detached from the plants, by grasping them firmly with the hand, and giving them a sort of a sudden twist. In favourable seasons, where the soils are rich, the plants will often rise to the height of eight or ten inches ; but in other circumstances, they seldom attain more than four or five : and where the lands are well managed they will often afford two or three gatherings, but the best cultivators seldom take more than two, which are sometimes mixed together in the manufacturing. It is necessary that the after-croppings, when they are taken, should be constantly kept separate from the others, as they would injure the whole if blended, and considerably diminish the value of the produce. It is said that the best method, where a third cropping is either wholly or partially made, is to keep it separate, forming it into an inferior kind of woad.

5973. *The produce* is mostly from about a ton to a ton and a half of green leaves. The price varies considerably ; but for woad of the prime quality, it is often from twenty-five to thirty pounds the ton, and for that of an inferior quality six or seven, and sometimes much more.

5974. *To prepare it for the dyer*, it is bruised by machinery to express the watery part ; it is afterwards formed into balls and fermented, re-ground, and fermented in vats, where it is evaporated into cakes in the manner of indigo. The haulm is burned for manure or spread over the straw-yard, to be fermented along with straw-dung.

5975. *The use* of woad in dyeing is as a basis for the black and other colours.

5976. *To save seed*, leave some of the plants undenuded of their leaves the second year, and when it is ripe, in July or August, treat it like turnip-seed.

5977. *The only diseases* to which the woad is liable are the mildew and rust. When young it is often attacked by the fly, and the ground obliged to be re-sown, and this more than once even on winter-ploughed grass lands.

SUBJECT. 6. *Weld, or Dyer's Weed.* — *Resèda Lutèola* L. ; *Dodecándria Trigýnia* L., and *Resedàceæ* Lindl. *Gaude*, Fr. ; *Waud*, Ger. (fig. 802.)

5978. *Weld* is an imperfect biennial, with small fusiform roots, and a leafy stem from one to three feet in height. It is a native of Britain, flowers in June and July, and ripens its seeds in August and September. It is cultivated in a few places in England, and chiefly in Essex, for its spike of flowers, and sometimes also for its leaves, both of which are used in dyeing. Its culture may be considered the same as that of woad, only being a smaller plant it is not thinned out to so great a distance. It has this advantage for the farmer over all other colouring plants, that it only requires to be taken up and dried, when it is fit for the dyer. It is, however, an exhausting crop.

5979. *Weld will grow on any soil*, but fertile loams produce the best crops. In Essex, it is grown on a stiff loam, moderately moist.



5981. *The crop is taken by pulling up the entire plant: and the proper period for this purpose is when the bloom has been produced the whole length of the stems, and the plants are just beginning to turn of a light or yellowish colour; as in the beginning or middle of July in the second year. The plants are usually from one foot to two feet and a half in height. It is thought by some advantageous to pull it rather early, without waiting for the ripening of the seeds; as by this means there will not only be the*

greatest proportion of dye, but the land will be left at liberty for the reception of a crop of wheat or turnips; in this case, a small part must be left solely for the purpose of seed.

5982. *In the execution of the work, the plants are drawn up by the roots in small handfuls; and, after each handful had been tied up with one of the stalks, they are set up in fours in an erect position, and left to dry. Sometimes, however, they become sufficiently dry by turning without being set up. After they have remained till fully dry, which is mostly effected in the course of a week or two, they are bound up into larger bundles, each containing sixty handfuls, and weighing fifty-six pounds. Sixty of these bundles constitute a load, and, in places where this kind of crop is much grown, are tied up by a string made for the purpose, which is sold under the title of weld cord.*

5983. *The produce of weld depends much on the nature of the season; but from half a load to a load and a half per acre is the quantity most commonly afforded. It is usually sold to the dyers at from five or six to ten or twelve pounds the load, and sometimes at considerably more. It is mostly bought by persons who afterwards dispose of it to the dyers. The demand for it is sometimes very little, while at others it is so great as to raise the price to a high degree. It is sometimes gathered green and treated like woad or indigo; but in general the dried herb is used by the dyers in a state of decoction.*

5984. *The use of weld in dyeing is for giving a yellow colour to cotton, woollen, mohair, silk, and linen. Blue cloths are dipped in a decoction of it, which renders them green; and the yellow colour of the paint called Dutch pink is obtained from weld.*

5985. *To save seed, select a few of the largest and healthiest plants, and leave them to ripen. The seed is easily separated.*

5986. *The chief disease of weld is the mildew, to which it is very liable when young, and this is one reason that it is often sown with other crops.*

SUBJECT. 7. Bastard Saffron. — *Carthamus tinctorius* L.; *Syngènesia Polygàmia Æqudlis* L., and *Cynarocéphalæ* J. *Carthame*, Fr.; *Wilder Safran*, Ger. (fig. 140. p. 174.)

5987. *The bastard saffron is an annual plant, which rises with a stiff ligneous stalk, two feet and a half or three feet high, dividing upwards into many branches, with ovate pointed sessile leaves. The flowers grow singly at the extremity of each branch; the heads are large, enclosed in a scaly calyx; each scale is broad at the base, flat, and formed like a leaf of the plant, terminating in a sharp spine. The lower part of the calyx spreads open, but the scales above closely embrace the florets, which stand out nearly an inch above the calyx; these are of a fine saffron colour, and this is the part which is gathered for the use of the dyer.*

5988. *It grows naturally in Egypt and some of the warm parts of Asia; but, being an annual, our summers admit of its going through a course of existence in this country. Sown in April, it flowers in July and August, and the seeds ripen in autumn; but if the season proves cold and moist, when the plants are in flower, there will be no good seeds produced; so that there are few seasons wherein the seeds of this plant come to perfection in England.*

5989. *It is cultivated in great plenty in Germany, and was formerly grown in England. In Houghton's Collections, it is related by a gentleman, in 1683, that twenty-five acres in the Vale of Evesham, in Gloucestershire, were sown with this seed; the soil a mixed sand of about fifteen shillings an acre in value; it bore a crop of wheat the year before, was dressed for barley, and had a harrowing extraordinary. This piece of ground was taken for two years by an adventurer in this seed, at the rate of twenty-five pounds per acre, in consideration that this plant is said to be a great impoverisher of land. He sold the flowers in London for 10l. per pound; a price, he said, much below his expectation. He gained above thirty shillings an acre clear profit, except the price of the seed; but of this there was a plentiful return (about one hundred and forty bushels), which, had it been well managed, would have amounted to a considerable value. Like*

most other manufactory plants it is considered an impoverisher of the ground; both by exhausting it, and by affording but little haulm as manure.

5990. *The soil* it requires is light, and the preparation and culture, according to Von Thaer, equal to that of the garden. The seed is sown in rows, or deposited in patches two feet apart every way, and when the plants come up, they are thinned out, so as to leave only two or three together. The soil is stirred and weeded during summer. In August the flowers begin to expand: the petals of the florets are then to be cut off with a blunt knife, and dried in the shade, or on a kiln, like the true saffron. This operation is performed in the early part of the day, and continued daily till October. The plants are then pulled up, sheaved and shocked, and threshed for their seed.

5991. *The use* of the flower of bastard saffron is chiefly in dyeing. It is also put in soups, pies, and puddings, like the leaves of the marigold or the common saffron. The oil produced from the seed is used both in medicine and painting. The stalks of the plants are commonly burnt for manure.

SUBSECT. 8. *Various Plants which have been proposed as Substitutes for the Thread and dyeing Plants grown in Britain.*

5992. *Though few of these are likely to come into cultivation*, yet it may be useful to notice them, with a view to indicating our resources for extraordinary occasions; to leading the young cultivator to reflect on the richness of that immense store-house, the vegetable kingdom; and to pointing out sources of experiment and research for the amateur agriculturist. Every kind of limitation has a tendency to degrade the mind, and lessen enterprise. The plants to be here enumerated, naturally arrange themselves as thread plants and colouring plants.

5993. *The thread plants* that have been tried are the *Asclèpias syriaca*, *Urtica dioica* (or nettle), *Urtica canadense* (or Canadian nettle), the *Spàrtium júnceum*, and *Cýtisis scopàrius* (brooms), *Epilòbium angustifòlium*, *Eriòphorum polystàchyon*, &c. The *Asclèpias syriaca*, Syrian swallow-wort, or Virginian silk, is a creeping-rooted perennial, with strong erect stems from four to six feet high. It is a native of Virginia, and flowers in July. The flowers are succeeded by pods, containing a down or cotton, which the poor people in Virginia collect and fill their beds with. In Germany, and especially at Leignitz, attempts were made, in 1790 and 1800, Von Thaer informs us, to cultivate the plant as a substitute for cotton. It was found to grow readily on a poor soil; but the growers could not undersell the importers, nor produce so good an article. The *Eriòphorum polystàchyon*, or cotton grass, grows abundantly in our bogs, and its seeds are furnished with a cottony substance, gathered by the country people to stuff pillows, &c. This substance has been spun and woven into very good cloth. The common nettle affords a fibre which has also been spun and manufactured. The fibre of the *Spàrtium júnceum*, rush-like, or Spanish broom, a native of the south of Europe, but quite hardy in Britain, is made into very good cloth both in the south of France and in Spain. The fibre of the common broom makes an inferior description of cordage in the former country. The *Epilòbium angustifòlium*, and other species of willow herb, common by the sides of brooks, afford a very good fibre, as do a great variety of plants: and in Sweden a strong cloth is made from the stems of the wild hop (*Hùmulus Lupulus*), and the same thing has been done in England. (*Trans. Soc. Arts.* 1791.) Indeed there are few plants the fibres of which might not be separated and rendered available for the purpose of spinning threads for weaving into cloth, or of mashing for making paper. The fibres of all nettles and square-stalked herbaceous plants answer for the former purpose; and both the fibres and bark of several plants, for the latter. The fibres of all the herbaceous mallows are uncommonly white, and finer than camel's hair; and in Germany they are used in making an imitation of India paper for engravers. The filaments of the common field-bean are among the strongest yet discovered: these, with a little beating, rubbing, and shaking, are easily separated from the strawy part, when the plant has been steeped ten or twelve days in water; or is damp, and in a state approaching to fermentation, or what is commonly called retting. Washing or pulling it through heckles, or iron combs, first coarse, and then finer, is necessary to the dressing of bean hemp; and is perhaps the easiest mode of separating the filaments from the thin membrane that surrounds them. The fibre of the common nettle is very similar to that of hemp or flax, inclining to either according to the soil and different situations in which it grows; and it has been shown by experiment, that they may be used for the same purposes as hemp or flax, from cloth of the finest texture down to the coarsest quality, such as sail-cloth, sacking, cordage, &c. (*Smith's Mechanic*, vol. ii.) It might be worth the attention of any one who had leisure to collect a few, say only two, stalks, of a great number of species from a botanic garden, to immerse them a sufficient time in soft soap and warm water, and prove their absolute and comparative value as fibre plants.

5994. *Broom flax* is prepared by steeping the twigs or most vigorous shoots of the former year, for two or three weeks, more or less, according to the heat of the season, in stagnant water, or by boiling them for about an hour in water. This done, the flax comes freely from the twigs; and, where there is not machinery for the purpose, may be easily peeled or stripped off; by children or others, at any time when not quite dry, in the same way as hemp is peeled from the stalks. Being cleared of the

flax, and steeped for some time in hoiling water, the twig, or wood, becomes tough and beautifully white, and is worth, at a medium, from a shilling to eighteen-pence per pound for making carpet brooms, &c. When stripped from the twigs, the flax requires only to be well washed in cold water, then wrung and shaken well, and hung out to dry, previously to its being sent off to the paper manufacturers. (*Smith's Mechanic*, vol. ii.)

5995. *Of colouring plants*, the number that may be, and even are employed, is almost endless. The reader has only to look into any botanical catalogue, and observe the number of plants whose specific names are formed from the adjective tinctòrius; and these, though numerous, are still only a small part. On looking into the *Flòra Britànnica*, or *Flòra Suécica*, he will there find a number of plants, trees, and even mosses and ferns used for dyeing. A number have been tried in this country and given up; as an instance, we mention *Gàlium verum*, which, in 1789, when the price of madder was high, was tried under the authority of the privy council for trade. The *Cròton tinctòrium*, *Genísta tinctòria*, *Rhàmnus cathàrticus* and *infectòrius*, and *Plantàgo Psýllium*, are cultivated in France as dyeing plants.

SECT. II. *Plants cultivated for the Brewery and Distillery.*

5996. *Of plants grown expressly for their use in the brewery*, the only one of consequence is the hop; the anise and caraway are grown on a very limited scale for the distillery.

SUBJECT. 1. *The Hop.* — *Humulus Lupulus* L. ; *Diœcia Pentândria* L., and *Urticææ* J. *Houblon*, Fr. ; *Hoppen*, Ger. ; *Lupolo*, Ital. ; and *Lupulo*, Span. (fig. 803.)



5997. *The hop* is a perennial-rooted plant, with an annual twining stem, which, on poles or in hedges, will reach the height of from twelve to twenty feet or more. It is a native of Britain, and most parts of Europe, in hedges, flowering in June, and ripening its seeds in September. The female blossom is the part used : and as the male and female flowers are on different plants, the female only is cultivated.

5998. *When the hop was first used for preserving beer*, or cultivated for that purpose, is unknown ; but its culture was introduced to this country from Flanders in the reign of Henry VIII. Walter Blith, in his *English Improver Improved*, 1649, the third edition, 1653, p. 240., has a chapter upon improvement by plantations of hops, &c. He observes, that “hops were then grown to be a national commodity : but that it was not many years since the famous city of London petitioned the parliament of England against two anuſancies ; and these were Newcastle coals, in regard to their stench, &c., and hops, in regard they would spoyl the taste of drink, and endanger the people ; and had the parliament been no wiser than they,

we had been in a measure pined, and in a great measure starved, which is just answerable to the principles of those men who cry down all devices or ingenious discoveries as projects, and thereby stifle and choke improvements.”

5999. *The hop has long been cultivated extensively* in many parts of England, but not much in Scotland or Ireland. According to Brown, hops are not advantageous in an agricultural point of view ; because much manure is abstracted by them, while little or none is returned. They are an uncertain article of growth, often yielding large profits to the cultivator, and as often making an imperfect return, barely sufficient to defray the expenses of labour. In fact, hops are exposed to more diseases than any other plant with which we are acquainted ; and the trade affords a greater room for speculation, than any other exercised within the British dominions. (Brown.) Parkinson in a paper on the culture of the hop in Nottinghamshire, published in the *Farm. Mag.* vol. xvi., observes that “the hop is said to be a plant very properly named, as there is never any certainty in cultivating it.”

6000. *There are several varieties of the hop.* The writer of *The Synopsis of Husbandry* distinguishes them under the titles of the Flemish, the Canterbury, the Goldings, the Farnham, &c., and says that the Flemish is held in the lowest estimation of any.

6001. *The Flemish hop*, he says, is of a smaller size, of a much closer contexture, and of a darker green colour, than any of the rest, and grows on a red bind ; and has so near an affinity to the wild or hedge-hop, that it would never answer for cultivation, did it not possess the property of resisting the blast with greater vigour than the other kinds ; so that, in years when these last are covered with flies and lice, the Flemish hop appears strong and healthy. At picking time, likewise, this kind of hop, he says, takes less damage, either by the sun or rain, than any other ; and upon these accounts, it may answer the views of the planter to have a few acres of it, which will secure him a crop in a blasting season, when those of the more valuable class are destroyed, so as to be worth nothing.

6002. *The soils most favourable to the growth of hops* are clays and strong deep loams : but it is also of great importance that the subsoil should be dry and friable ; a cold, wet, tenaceous, clayey understratum being found extremely injurious to the roots of the plants, as, when they penetrate below the good soil, they soon become unproductive, and ultimately decay.

6003. *A chalky soil*, Bannister says, is, of all others, the most inimical to the growth of this vegetable ; the reason of which he takes to be the dry and parching quality of the chalk, by which the roots are prevented from absorbing a quantity of moisture, equal to the supply to the vine or bind with sap during its growth ; for though a dripping summer is by no means kindly to the welfare of the hop, yet since the vine in a healthy state is very luxuriant, and furnished with a large abundance of branches, leaves, fruit, &c., it follows that the demand of moisture from the soil must be proportionably great to preserve the plant in health and vigour ; and for this reason the ground ought not to be deficient in natural humidity. Hence we generally find the most luxuriant vine growing on deep and rich land, as moulds, &c. ; and in these grounds it is common, he says, to grow a load on an acre. But it is to be observed, however, that the abundance of fruit is not always in proportion to the length of the vines ; since those soils which, from their fertility, cause a large growth of vine are more frequently attacked by the blast, than land of a shallower staple where the vine is weaker and less luxuriant.

6004. *But though rich moulds generally produce a larger growth of hops than other soils*, there is one exception to this rule, where the growth is frequently eighteen or twenty hundred per acre. This is on the rocks in the neighbourhood of Maidstone, in Kent, a kind of slaty ground, with an understratum of stone. On these rocks there is a large extent of hop-garden, where the vines run up to the tops of the longest poles, and the increase is equal to that on the most fertile soil of any kind.

6005. *The most desirable situation for a hop plantation* is ground sloping gently towards the south or south-west, and screened, by means of high grounds or forest-trees, from the north and north-east. At the same time it ought not to be so confined as to prevent that free circulation of air which is indispensably necessary where plants grow so close together, and to such a height. A free circulation of air, in a hop-ground, not only conduces to the health and vigour of the plants, but also prevents the crops from being blighted, or what the hop-farmers call fire-blasted, which often happens towards the middle of a large close-planted hop-ground ; while the outsides, in consequence of the more free circulation of air that there takes place, receive no injury whatever.

6006. *Bannister* asserts, that those fields which lie within a few miles of the sea, or in the neighbourhood of marshy or fenny levels, are seldom favourable to the growth of hops, as such grounds generally miscarry in a blasting year ; and though, from the fertility of the soil, they may perhaps bring a plentiful crop in those seasons when the growth is general, such a situation is eligible for a hop ground. In Worcester-shire and Herefordshire hops are very generally grown between the rows of fruit trees in dug or ploughed orchards.

6007. *In preparing the soil* previously to planting, considerable attention is necessary, by fallowing, or otherwise, to destroy the weeds, and to reduce the soil to as pulverised a state as possible. The ridges should also be made level, and dung applied with a liberal hand. The most effectual preparation is trenching either by the plough or by manual labour.

6008. *The mode of planting* is generally in rows, making the hills six feet distant from each other; though there are some people who, from avaricious motives, prefer a five-foot plant. But as this vegetable, when advanced in growth, produces a large redundancy of bind or vine, and leaves, it should seem that six feet cannot be too wide a distance; and that those which are planted closer will, from too confined a situation, be prevented from enjoying a free circulation of the air; from which much injury may proceed, as blasts, mildews, moulds, and other accidents, not to mention the disposition of the vine to house or grow together at the tops of the poles, whereby the hops are so overshadowed as to be debarred the influence of the sun, and prevented from arriving at half their growth.

6009. *As the planters differ in the number of hills* to be made on the same given quantity of land, so are they no less capricious as to the manner of placing them; some choosing to set them out with the most cautious regularity in rows of equal distances, whilst others prefer planting in quincunx. The former method has this advantage; that the intervals may, in the early part of the summer, be kept clean by means of the cultivator and harrow; but, in the latter method, these implements are rendered inadmissible by the irregular station of the plants; and the ground must be tilled with the hoe at a greatly increased expense, as the same labour might be performed to as much advantage with one horse, a man, and a boy, who will do more work in a day than half a dozen labourers can with a hoe.

6010. *The ordinary season for planting* is spring, in February or March; but if bedded plants, or such as have been nursed for one summer in a garden, are used, then by planting in autumn some produce may be had in the succeeding year. But, according to the author of *The New Farmer's Calendar*, "the time for planting is commonly that of dressing and pruning the old vines when cuttings may be had, which is in March or April; but when root-sets are used, as on the occasion of grubbing up an old plantation, October to the beginning of November. But at whatever period they are planted, great care should be taken that the same sorts be planted together, as by this means there are advantages derived in their after-culture."

6011. *The plants or cuttings are procured* from the old stools, and each should have two joints or eyes; from the one which is placed in the ground springs the root; and from the other the stalk, provincially the bind. They should be made from the most healthy and strong binds, each being cut to the length of five or six inches. Those to be nursed are planted in rows a foot apart, and six inches asunder, in a garden; and the others at once where they are to remain.

6012. *The mode of performing the operation of planting in Kent* is as follows:—

6013. *The land having been previously cleaned and prepared*, dung is laid on the field in small heaps near the places where it is proposed to plant the hop slips or sets. These places are commonly marked off, by infixing a number of stakes at proper and regular distances; that done, small pits are formed by taking out a spit, or spade's depth of earth; and the earth below being gently loosened, a certain quantity, about half a bushel, of dung is laid thereon; then the earth that was formerly taken out is again replaced, and so much added as to form a small hillock. On this hillock, five, six, or seven sets, procured from the roots or shoots of the old stock, are dibbled in. The plants are placed in a circular form towards the top of the hillock, and at the distance of five or six inches from each other. They are made to incline towards the centre of the hillock, where another plant is commonly placed.

6014. *Another mode of planting* is as follows:—Strike furrows with the plough at equal distances of eight feet; when finished, repeat the same across in the opposite direction, which will divide the piece into eight-foot squares. The hills are to be made where the furrows cross each other, and the horse-hoe may be admitted between the rows both ways. According to the Suffolk husbandry, the plantations are formed into beds sixteen feet wide, by digging trenches about three feet wide, and two or three feet deep; the earth that comes out being spread upon the beds, and the whole dug and levelled. Upon this they, in March, form the holes six feet asunder every way, twelve inches diameter, and a spit deep, by which three rows are formed on each bed. Into each hole they put about half a peck of very rotten dung, or rich compost, and scatter earth upon it; and in each they plant a set, drawing earth enough to it afterwards to form something of a hillock.

6015. *An interval crop* is generally taken in the first summer of a hop plantation. Beans are very generally grown; and Bannister is of opinion that two rows of beans may be planted in each interval without any damage to the hops, whether bedded sets or cuttings. In the latter case, this method may be pursued in the second year, at the end of which the vine from the cuttings will not be in a more forward state than that from the bedded sets in the first autumn after planting. Others, however, think that neither beans, cabbages, nor any other plants, except onions, should be put in.

6016. *The after-culture of the hop*, besides the usual processes of hoeing, weeding, stirring, and manuring, includes earthing-up, staking, and winter dressing.

6017. *Hoeing* in hop plantations may always be performed by a horse implement; and one in use for this purpose in the hop counties, and of which the expanding horse-hoe (*fig. 335.*) is an improvement, is known by the name of hop-nidget. When the hop-stools are formed in the angles of squares, the intervals may be hoed both lengthwise and across, and thus nothing is left to be performed by manual labour but pulling out any weeds which may rise in the hills.

6018. *Stirring*, in the hop districts, is chiefly performed in winter with a three-pronged fork (provincially spud); but it might be equally well effected then or at any season of the year with the common plough, and the expanding horse-hoe set with coulters or prongs. With the latter implement the soil might be stirred to any desirable depth, either in summer or winter; and, with the plough, the surface could be changed at discretion. Once going and returning would effect this, either by the paring or clearing out;

that is, forming either a ridglet, or gutter between the rows, both lengthwise and across. Twice or thrice going in the same direction would also succeed, and would be the preferable mode of covering in manure.

6019. *In the application of manure*, various modes are adopted. Some always use well rotted stable dung; others, composts of earth and dung; and a few, littery dung. In laying it on, many prefer the autumn to the spring, and heap it on the hills without putting any between the rows. Others put it all between the rows, alleging that laying it on the hills encourages insects, exposes the dung to evaporation and loss, and sometimes, when mixed with earth, hinders the plants from coming up. A great deal will be found in favour of, and against each of these modes, in the numerous works on the culture of the hop, which have been written during the last three centuries; but it must be obvious to any person generally conversant with vegetable culture, that well rotted stable dung must be the best kind for use; and early in spring the best season for laying it on; that little benefit can be derived by the roots when it is laid on the hills, and, consequently, that it ought to be turned into the soil between the rows by the plough. Fifty cart-loads of dung and earth, or thirty of dung, once in three years, is reckoned a good dressing; but some give ten or twelve loads every year. Too much dung renders the hops what is called mouldy, and too little causes the crop to be poor and more liable to be eaten by insects.

6020. *Earthing-up* commences the first May after planting, whether that operation be performed in spring or autumn. By the end of the spring season, the young shoots have made some progress, and the earth is then drawn up to their roots from the surrounding intervals, in order to strengthen them. The next earthing-up is in autumn, when the hills are by some covered with compost or manure; but by such as prefer ploughing in the manure between the rows, this earthing-up is not given. Some give an earthing-up of this kind in spring, and generally in February, chiefly to retard the plants, as that is found to render them less liable to disease, and the attacks of insects; for the shoots not beginning to grow till the weather is warm, they then shoot more rapidly. In April and May, their progress is slow; but in June and July, when the nights are warm, they will grow nearly an inch in the hour. The only essential earthings up, however, are those given the first year in May, and those given annually after the operation of dressing, whether in autumn or spring, which indeed may be called replacings of earth, rather than earthings-up.

6021. *In dressing the hop plants*, the operations of the first year are confined to twisting and removing the haulm, to which some add cuping or earthing-up in autumn.

6022. *The operation of twisting* is confined to such plants as have been planted in spring, and are not expected to produce any crop that season. It is performed in the end of June or in July, and consists in twisting the young vines into a bunch or knot; so that, by thus discouraging their growth, the roots are enabled to spread out more vigorously, and to acquire strength previously to the approach of the winter season.

6023. *Removing the haulm* takes place soon after Michaelmas, and consists simply in cutting it over with a sickle, and carrying it off the field for litter or burning. After this operation, some add cuping, or covering the hill with a compost; but this does not appear necessary, and is in many cases left undone.

6024. *The first year's dressing* of hops expected to produce flowers, such as those planted from bedded sets in the preceding autumn, consists in supplying three or four half poles, that is, poles of four or five feet in length to each hill, and on removing the haulm in autumn, as in the other case.

6025. *The yearly dressing of established hop plantations* consists of what is provincially called picking. This operation is gene-

6026. *The yearly operation of stacking or setting the poles* commences towards the end of April, or at whatever period, earlier or later, the shoots may have risen two or three inches.

6027. *The poles are straight slender shoots of underwood*, ash, oak, chestnut, or willow, from sixteen to twenty feet high. These poles are set two, but more frequently three, to a hill; and are so placed as to leave an opening towards the south, to admit the sunbeams. The manner of fixing them is by making deep holes or openings in the ground with an iron crow. Into these holes the root-ends are put, when the earth is rammed so hard about them, that they very seldom alter from the position in which they were placed, except on occasion of very violent gales of wind. Great care is necessary in placing the poles, and no less judgment and experience in determining what ought to be the proper height. When very long poles are set in a hop-ground, where the stocks are too old or too young, or where the soil is of indifferent quality, the stocks are not only greatly exhausted, but the crop always turns out unproductive; as, till the vines reach the top, or rather till they overtop the poles, which depends on the strength of the stocks and the quality of the soil, the lateral branches on which the hops grow never begin to shoot out, or make any progress.

6028. *Planters are much divided in their sentiments as to the number of poles to be set against each hill.* Three poles are the general allowance, observing to place the stoutest pole to the northern aspect of the hill; though it is no uncommon practice to set four poles, and in strong land five or six, to a hill. In behalf of this latter mode it is urged, that, where the land usually produces a great redundancy of vine, it is prudent to set a number of poles answerable to the luxuriance of the shoots. But, if a free circulation of the air be a matter of such importance to the well-being of a crop of hops as is generally imagined (and this is a doctrine which, it is believed, cannot be controverted), the incumbering of the hills with an additional number of poles cannot fail to be of infinite dis-service to the future growth of the hops; and it will be readily acknowledged, that the quantity of hops on the same given number of hills will be more considerable where three poles only are set up, than where the hills are crowded with a larger number; whether we consider the mischief likely to accrue from the stagnated air, or from the redundancy of the vine, by which the hops are prevented from arriving to their proper size or growth. The chief art in poling a hop-ground is, first, to pitch the hole to a proper depth, about twenty inches; next, to set down the pole with some exertion of strength, so that being well sharpened it may fix itself firmly at the bottom; thirdly, that the tops of the poles may stand in such a direction as to lean outwards from the hill, to prevent, as much as possible, the housing of the vine; and lastly, to tread the earth close to the pole with the foot. For want of regard to these particulars in the labourer, a moderate blast of wind will loosen the poles, so as not only to occasion a double expense, but the hazard of injuring the future crop by tearing asunder the vine, which, from its great luxuriance, will become twisted together, or, as it is termed, housed at the extreme parts of the poles.

6029. *With respect to the species of woods proper for poles*, it is suggested that the hop appears to prefer a rough soft bark, to one which is more smooth and polished. An experienced grower particularises the maple, whose bark is peculiarly soft and warm; adding, that he has frequently observed, when the morning has been cold, the sensitive leader of a tender fresh

rally commenced on the return of good weather, in March, when the hills are spread out, in order to give opportunity to prune and dress the stocks. The earth being then cleared away from the principal roots by an iron instrument called a picker, the remains of the former year's vines are cut off, together with the shoots which were not allowed to attach themselves to the poles in the former season, and also any young suckers that may have sprung up about the edges of the hills; so that nothing is allowed to remain that is likely to injure the principal roots, or impede their shooting out strong vigorous vines at the proper season. After the roots have been properly cleaned and pruned, the hills are again formed, with an addition, if not every year, at least every second or third year, of a proper quantity of compost manure, that had been previously laid in small heaps on the hop-ground in the course of the winter, or in the early part of spring. At this season such sets are procured as may be wanted for the nursery, or for new plantations.

poled vine reclining its head against the velvet bark of the maple, while others held theirs aloof, from chilly smooth-barked poles. This is probably more fanciful than correct, since we find the hop twining with equal luxuriance round the smooth-barked ash and the rough-barked larch or acacia; and with respect to chilly smooth poles, the hop is known to twine with as much vigour round iron or copper wire as round any wood whatever. (*Gard. Mag.* vol. vii.)

6030. *In regard to the size of the pole*, hops, likewise, it is well known, have their instinctive choice or approbation, with respect to the thickness of their support; embracing, with greater readiness, a pole that is moderately small, than one which is thick at the bottom. The ordinary circumference of poles, at the thickest end, may be set down at from six to nine inches, tapering to the size of a walking-cane at the top; and the length from fifteen to twenty feet, or upwards. Different grounds require different lengths of pole. In the rich grounds, in the neighbourhood of Maidstone, the poles of grown hops stand, in general, from fourteen to sixteen feet above the hills, and have from eighteen inches to two feet beneath the surface. But, on weaker lands, poles are not seen to rise more than ten to twelve feet high. Hence, a variety of ground is convenient; as the poles, by decaying at the roots, grow shorter, and, in a course of years, get too short for strong vines, on rich land. They are, in this case, sold, and transferred to less productive lands, and vines of humbler growth.

6031. *New poles have sometimes the bark shaved off*, under an idea that it saves them from the worm; while some men are of opinion that there is a warmth in the bark, which is acceptable to the young vines; and although in two or three years the bark drops off, the surface of the wood has, by that time, acquired a degree of softness. Whether a hard, smooth, polished pole is unfriendly to the hop or not, to peel the poles would evidently be improper, as promoting their decay.

6032. *Short light poles are usually pointed in hand*, without other support; but the tall heavy pole requires something to keep the top steady. This is obtained by tying together three poles of equal length, two or three feet from their tops; and setting them up in the form of what is called a triangle, in use for loading timber on wheel-carriages. The top of the pole to be sharpened, being dropped in between the points or horns of the triangles, receives the required stay; and a block is placed in a convenient situation below to work upon. This sort of work, whether on new or on old poles, is sometimes done before they are stacked, or set up in piles; sometimes immediately before they are used. In pointing poles that have been used, the part which stood in the ground the preceding year is, if much tainted, struck off, and a fresh point given to the sound part; but, if the bottom part remains firm, it is sharpened again for another season.

6033. *Wires of copper or iron* have been tried as substitutes for wooden poles in the north of France; but, having seen a plantation treated in this way, we do not think it any improvement. The wires are stretched horizontally in the direction of the row of plants, the first wire five feet from the ground, the second one foot above that, and so on, say to the height of fifteen feet. The plants are led to the lowest wire by short sticks, and left to twine up or along the others at pleasure.

6034. *Tying the shoots or vines to the poles* is the last operation in the after or summer culture of the hop. This requires the labour of a number of persons, generally women, who tie them in several different places with withered rushes, but so loosely as not to prevent the vines from advancing in their progress towards the tops of the poles. When the vines have got out of reach from the ground, proper persons go round, with standing ladders, and tie all such as appear inclined to stray.

6055. *The season for this operation* varies from the middle of May to the end of June, and one important part of the operation consists in selecting the shoots. The forwardest vine should always be extirpated, as it is well known that the branches arising from these early shoots will produce little, if any, fruit. The second shoots, where the hills are not overloaded with plants, and where the ground is not of a nature to send forth a very luxuriant vine, may with safety be tied up: but where the land is apt to push forward a great redundancy of shoots, where the vine is always strong and vigorous, and where the failure in the crop chiefly arises from this cause, the greatest prudence is necessary, at the season for tying, to make choice of a proper vine; especially in years which may be supposed to be attended with a blast; such as those wherein an easterly wind has prevailed throughout the month of March, whence one may fairly conclude that the same weather will happen during the course of the month of May, which never fails to

bring the long-winged fly. In such a season it would be well worth while to eradicate all the vine which first appears, and trust to a later shoot, so as to protract the tying till the last week in May. This hint was taken from the observations made in such blasting years on the poor and thin lands where the vine is naturally backward, and seldom becomes fit for the tyers till towards the latter end of May, when that on the forward ground will have advanced nearly to the tops of the poles, and to an inattentive observer seems to promise fair for a crop; whereas, to those who have been conversant in these matters, the loss of the crop, though the vine at that time be green and flourishing, may be easily foreseen; whilst on the poorer soils there is generally a saving crop even in years when the blast is most prevalent. These considerations have suggested the protracting of the growth of the vine in the manner above mentioned, which seems conformable to reason and experience.

6036. *Taking the crop* is a most important operation in the hop economy

6037. *Hops are known to be ready for pulling* when they acquire a strong scent, and the seeds become firm and of a brown colour, which, in ordinary seasons, happens in the first or second week of September. When the pulling season arrives, the utmost assiduity is requisite on the part of the planter, in order that the different operations may be carried on with regularity and despatch; as the least neglect, in any department of the business, proves in a great degree ruinous to the most abundant crop, especially in precarious seasons. Gales of wind at that season, by breaking the lateral branches, and bruising the hops, prove nearly as injurious as a long continuance of rainy weather, which never fails to spoil the colour of the crop, and thereby render it less saleable.

6058. *As a preparation for pulling the hops*, frames of wood, in number proportioned to the size of the ground, and the pickers to be employed, are placed in that part of the field which, by having been most exposed to the influence of the sun, is soonest ready. These frames, which are called *bins* or *cribs*, are very simple in the construction, being only four pieces of boards nailed to four posts, or legs, and, when finished, are about seven or eight feet long, three feet broad, and about the same height. A man always attends the pickers, whose business it is to cut over the vines near the ground, and to lay the poles on the frames to be picked. Commonly two, but seldom more than three, poles are laid on at a time. Six, seven, or eight pickers, women, girls, and boys, are employed at the same frame, three or four being ranged on each side. These, with the man who sorts the poles, are called a set. The hops, after being carefully separated from the leaves and branches, or stalks, are dropped by the pickers into a large cloth, hung all round within-side the frame on tenter-hooks. When the cloth is full, the hops are emptied into a large sack, which is carried home, and the hops laid on a kiln to be dried. This is always done as soon as possible after they are picked, as they are apt to sustain considerable damage, both in colour and flavour, if allowed to remain long in sacks in the green state in which they are pulled. In very warm weather, and when they are pulled in a moist state, they will often heat in five or six hours: for this reason the kilns are kept constantly at work, both night and day, from the commencement to the conclusion of the hop-picking season.

6059. *To set on a sufficient number of hands* is a matter of prudence, in the picking season, that the oasts or kilns may never

6041. *The operation of drying hops* is not materially different from that of drying malt; and the kilns, or oasts, are of the same construction.

6042. *The hops are spread on a hair-cloth*, and from eight to ten, sometimes twelve, inches deep, according to the dryness or wetness of the season and the ripeness of the hops. A thorough knowledge of the best method of drying hops can only be acquired by long practice. The general rules are, to begin with a slow fire, and to increase it gradually, till, by the heat on the kiln, and the warmth of the hops, it is known to have arrived at a proper height. An even steady fire is then continued for eight or ten hours, according to the state or circumstances of the hops, by which time the ends of the hop-stalks become quite shrivelled and dry, which is the chief sign by which to ascertain that the hops are properly and sufficiently dried. They are then taken off the kiln, and laid in a large room or loft till they become quite cool. They are now in condition to be put into bags, which is the last operation the planter has to perform previously to sending his crop to market.

6043. *When hops are dried on a cockle-oast*, sea-coal is the usual fuel, and a chaldron is generally esteemed the proper allowance to a load of hops. On the hair kilns, charcoal is commonly used for this purpose. Fifty sacks of charcoal are termed a load, which usually sells for about fifty shillings. The price for burning is three shillings per load, or twelve shillings for each cord of wood. The process of drying having been completed, the hops are to be taken off the kiln, and shovelled into an adjoining chamber called the stowage-room; and in this place they are continually to be laid as they are taken off the kiln, till it may be thought convenient to put them into bags, which is rarely done till they have lain some time in the heap; for the hops, when first taken off the kiln, being very dry, would (if put into the bags at that time) break to pieces, and not draw so good a sample as when they have lain some time in the heap; whereby they acquire a considerable portion of toughness, and an increase of weight.

6044. *The bagging of hops* is thus performed:—

6045. *In the floor of the room, where the hops are laid to cool*, there is a round hole or trap, equal in size to the mouth of a hop bag. After tying a handful of hops in each of the lower corners of a large bag, which serve afterwards for handles, the mouth of the bag is fixed securely to a strong hoop, which is made to rest on the edges of the hole or trap; and the bag itself being then dropped through the trap, the packer goes into it, when a person who attends for the purpose puts in the hops in small quantities, in order to give the packer an opportunity of packing and trampling them as hard as possible. When the bag is filled, and the hops trampled in so hard as that it will hold no more, it is drawn up, unloosed from the hoop, and the end sewed up, other two handles having been previously formed in the corners in the manner mentioned above. The brightest and finest coloured hops are put into pockets or fine bagging, and the brown into coarse or heavy bagging. The former are chiefly used for brewing fine ales, and the latter by the porter brewers. But it is to be observed, that where hops are intended to be kept for any length of time, it is most proper to put them into coarse cloth. The proper length of a bag is two ells and a quarter, and of a pocket nearly the same, being one ell in width. The former, if the hops are good in quality, well cured, and tight trodden, will weigh about two hundred and a half; and the latter, if of the Canterbury pocketing, about one hundred and a half. If the weight either exceeds or falls much

be unsupplied with hops; and if it is found that the hops rise faster than could have been expected, and that there are more gathered in a day than can be conveniently dried off, some of the worst pickers may be discharged; it being very prejudicial for the green hops to continue long in the sacks before they are put on the oast, as they will in a few hours begin to heat, and acquire an unsightly colour, which will not be taken off in the drying, especially if the season be very moist; though, in a wet hopping, it is no easy matter to prevent the kilns from being overrun, supposing that there were pickers enough to supply them if the weather had been dry, because in a wet cold time the hops require to lie a considerable while longer on the kiln, in order that the superabundant moisture may be dried up. It is therefore expedient in this case that each measuring be divided into a number of green pockets or pokes. The number of bushels in a poke ought never to exceed eleven; but when the hops are wet, or likely to continue together some time before they go on the kiln, the better way is to put only eight bushels in a sack, pocket, or poke.

6040. *Donaldson* asserts that diligent hop-pickers, when the crop is tolerably abundant, will pick from eight to ten bushels each in the day, which, when dry, will weigh about one hundred weight; and that it is common to let the picking of hop-grounds by the bushel. The price is extremely variable, depending no less on the goodness of the crop than on the abundance or scarcity of labourers. The greatest part of the hops cultivated in England is picked by people who make a practice of coming annually from the remote part of Wales for that purpose.

short of this medium, it induces a surmise, that the hops are either in themselves of an inferior quality, or have been injudiciously manufactured in some respect or other.

6046. *Fallance's apparatus for packing and preserving hops*, is a hexagonal case of wood, eighteen feet long and two feet in diameter, with a piston or rammer, to be worked by a screw or other means so as to compress the hops more closely than has hitherto been done. When the case is full, a lid is fastened down by iron plates and nails, and any crack or joint that may appear is filled with cement, so as to exclude the air. With this precaution, Mr. Fallance states, hops may be kept perfectly good for half a century. (*Newton's Journal*, vol. vii. p. 12.)

6047. *The stripping and stacking of the poles* succeed to the operation of picking. It is of some consequence that this business be executed as soon as possible after the crop is removed; not only because the poles are, when set up in stacks, much safer from thieves, but because they are far less damaged by the weather than when dispersed about the ground with the vine on them. The usual price for stripping and stacking is five shillings per acre. At this time, such poles as may be deemed unfit for further service should be flung by, that the planter may have an early knowledge of the number of new poles which will be wanted; and thus the business of bringing on the poles may be completed in the winter time, when the horses are not required about other labour; and these new poles may be drawn from the wood on the ground, and adjusted to the separate stacks, as the state of the different parts of the ground may require, and the whole business finished before the poling season: whereas, when this method of flinging out the old poles is neglected at the stacking, the planter, being ignorant of the number of new poles that will be required for the ensuing year, often finds at the poling season that he has not laid in a sufficient stock.

6048. *In performing the operation of stacking* the poles are set up in somewhat conical piles, or congeries of from two hundred to five hundred each. The method of proceeding is this:— Three stout poles of equal length are bound together, a few feet from their tops, and their feet spread out, as those already mentioned for pointing the poles. These serve as a stay to the embryo pile; the poles being dropped in on each side, between the points of the first three, cautiously keeping an equal weight on every side; for on this even balance the stability of the stack depends. The degree of inclination or slope, and the diameter of the base of the pile, vary with the length and the number of poles set up together. A stack of three or four hundred of the long poles of the environs of Maidstone, occupy a circle of near twenty feet in diameter. It is observable, however, that the feet of the poles do not form one entire ring; but are collected in bundles or distinct divisions, generally from three to six or eight in number; each fasciculus being bound tightly together, a few feet from the ground, with a large rough rope made of twisted vines, to prevent the wind from tearing away the poles. The openings between the divisions give passage to violent blasts, and tend to prevent the piles from being thrown down in a body: a circumstance which does not often take place in screeded grounds; but, on the high exposure of Cox Heath, where great quantities of new poles brought out of the Weald are piled for sale among the Maidstone planters, it is not uncommon for the piles to be blown down, and to crush in their fall the sheep or other animals that may have taken shelter under them. A caution this to the inexperienced in the business of stacking; and an apology, if one is wanted, for the minuteness of the detail.

6049. *The operation of stripping* is generally performed by women; being nothing more than tearing off the bind or vines. Many people burn it on the ground; others suffer it to be carried off by their workmen for firing; and there are some who tie it up into small bundles, which they bring home and form into a stack, to answer the purpose of bavins in heating their ovens or coppers.

6050. *The produce* of the hop crop is liable to very considerable variation, according to soil and season, from two or three to so much as twenty hundred-weight; but from nine to ten, on middling soils, in tolerable seasons, are considered as average crops, and twelve or fourteen as good ones. Bannister asserts that sixty bushels of fresh-gathered hops, if fully ripe, and not injured by the fly or other accident, will, when dried and bagged, produce a hundred-weight. Where the hops are much eaten by the flea, a disaster which often befalls them, the sample is not only reduced in value, but the weight diminished; so that, when this misfortune occurs, the planter experiences a two-fold loss.

6051. *To judge of the quality* of hops, as the chief virtue resides in the yellow powder contained in them, which is termed the condition, and is of an unctuous and clammy nature, the more or less clammy the sample appears to be, the value will be increased or diminished in the opinion of the buyer. To this may be added the colour, which it is of very material consequence for the planter to preserve as bright as possible, since the purchaser will always insist much on this article; though, perhaps, the brightest-coloured hops are not always the strongest flavoured.

6052. *The duration of the hop plantation* on good soil may be from fifteen to thirty years; but in general they begin to decline about the tenth year. Some advise that the plantation should then be destroyed, and a fresh one made elsewhere; others consider it the best plan to break up and plant a portion of new ground every two years, letting an equal quantity of the old be destroyed, as in this way a regular succession of good plantation will be kept up at a trifling charge.

6053. *The expense of forming new hop-plantations* is in general very great, being estimated, in many districts, at from not less than seventy to a hundred pounds the acre. The produce is very uncertain; often very considerable; but in some seasons nothing, after all the labour of culture, except picking, has been incurred. Where the lands are of proper sort for them, and there are hop-poles on the farm, and the farmer has a sufficient capital, it is probably a sort of husbandry that may be had recourse to with advantage; but under the contrary circumstances, hops will seldom answer. In growing them in connection with a farm, regard should be had to the extent that can be manured without detriment to the other tillage lands. On the whole, the hop is an expensive and precarious crop, the culture of which should be well considered before it is entered upon.

6054. *The use of the hop in brewing* is to prevent the beer from becoming sour.

6055. *In domestic economy* the young shoots are eaten early in the spring as asparagus, and are sold under the name of hop-tops. They are said to be diuretic; and taken in an infusion, to be good against the scurvy. The herb will dye wool yellow. From the stalks a strong cloth is made in Sweden: for this purpose they must be gathered in autumn, soaked in water all winter; and in March, after being dried in a stove, they are dressed like flax. They require a longer time to rot than flax, and, if not completely macerated, the woody part will not separate, nor the cloth prove white or fine. Hence a farmer who has a hop plantation need neither grow asparagus nor flax, and may, when the flowers fail from disease, separate the fibre from the vine, and employ the poor, or machinery, in spinning and weaving it. A decoction of the roots of hops is considered as good a sudorific as sarsaparilla; and the smell of the flowers is found to be soporific. A pillow filled with hops was prescribed for the use of George III. in his illness of 1787.

6056. *The hop is peculiarly liable to diseases.* There is scarcely any sort of plant cultivated as a field-crop that is more liable to become diseased than the hop. It is apt, in the very early stage of its growth, to be devoured, as it rises above the surface of the ground, by the ravages of an insect of the flea kind. At a more advanced stage, it is subject to the still more injurious effects of the green or long-winged fly, red spider, and otter moth: the first, by the depositing of their ova, afford the means of producing lice in great abundance, by which the plants are often very greatly, if not wholly, destroyed; and the larvæ of the last prey upon the roots, and thus render the plants weak and subject to disease. The honey-dew is another disease to which the hop is exposed about the same time, and by which it is often much injured. The mould occurs in general at a somewhat later period, and is equally injurious. Hop-crops are also exposed to other injuries, as the blight and fire-blast; but which take place at different times, though mostly towards the latter periods of the growth of the plants.

6057. *The flea*, which is said to be an insect of the same kind as that which is so prejudicial to the young turnip, is observed to make the greatest havoc in seasons when the nights are cold and frosty, and the days hot and inclined to be dry; eating off the sweet tender tops of the young plants, which, though not wholly destroyed, shoot forth afterwards in a far less vigorous manner, and of course become more exposed to diseases. It has been found to commit its depredations most frequently on the plants in grounds that have been dunged the same year: on which account it has been suggested that the manure employed for the purpose of covering the hills should be previously well mixed and incorporated, as directed above (6019.); and that it should be applied either over the whole of the land, or only the hills, as soon as possible after the plants have been cut over; but the former practice is probably the best. It makes its greatest depredations in the more early, cold, spring months, as the latter end of April and beginning of the succeeding month, disappearing as the season becomes more mild and warm. In these cases, the principal remedy is that of having the land in a sufficient state of fertility, to enable the young plants to shoot up with such vigour and rapidity as to become quickly incapable of being fed upon and devoured by the insect. The frequent stirring of the mould about the roots of the plants with the hoe may be of utility in the same view.

6058. *The green or long-winged fly* is highly destructive to the young leaves of the plants, and mostly makes its appearance about the latter end of May, and in the two succeeding months; being ignorantly supposed to be produced by the prevalence of north-easterly winds about that period. Under such a state of the wind, they are said to scarcely ever fail of covering the leaves; and by dropping their ova, of producing abundance of lice, which often much injure the crops; as when they have once obtained complete possession of the plants, they seldom or never leave them before they have wholly destroyed them. Insects of this sort generally attack the forwardest and most luxuriant hop-vines. Their removal chiefly depends upon the wind's changing more to the south, and the setting in of more mild, warm, and temperate weather.

6059. *The otter moth*, by depositing its eggs upon the roots of the plants, renders them liable to be attacked by the larvæ, and the healthy growth of the hops is thereby greatly impaired, the crops being of course much injured in their produce. Stirring the earth well about the roots of the plants may probably sometimes be serviceable in cases of this kind.

6060. *The honey-dew* mostly occurs after the crops have been attacked by some of these kinds of insects, and when the weather is close, moist, and foggy. In these cases, a sweet clammy substance, which has the taste of honey, is produced upon the leaves of the plants, and they have at first a shining appearance, but soon afterwards become black. It is a disease that mostly happens in the more forward crops; and the chief dependence of the planter for its removal, according to Bannister, is that of heavy thunder showers taking place; as by this means, when the destruction of the hops has not proceeded too far, they are often much restored, the insects that devour the leaves and vines being greatly destroyed, the growth of fresh shoots promoted, and a favourable bloom brought on the plants.

6061. *The fen, mould, or mildew*, is a disease to which the crop is exposed at a later period of its growth, and which chiefly attacks the part where the hop is attached to the stem. It is said that its production is greatly promoted by moist damp weather, and a low situation; those crops that grow on low, close, rich grounds being most liable to be attacked by it: and it is found to soon spread itself over the whole crop, after it has once seized upon any part of it. The nature of this vegetable disease has not been yet sufficiently investigated. It has been suggested by Darwin and Willdenow to be a plant of the fungus kind, capable of growing without light or change of air, attaching itself to plants already in a morbid condition, and by its roots penetrating their vessels: and on this supposition, the best remedy is believed to be thinning the plants, in order to afford a more free circulation of air, and admit the light more extensively, by which the vigour of the hop-plants may be restored, and the disease be of course removed. In this view, it is probable, by planting the hills more thinly, and making them at greater distances from each other, the disease might in some measure be prevented from taking place. (See 1694.)

6062. *Diseases termed blights* are frequently met with in hop-crops, at different periods of the growth of the plants, but mostly in the more early stages of their rising from the hills, while the nights are cold and frosty in the spring months, and the days have much sun and heat; by which the living powers of the plants are greatly exhausted in the day-time by the stimulus of heat, and of course much injured or wholly destroyed in the nights, from being exposed to a freezing air, which is incapable of exciting the actions necessary for the preservation of vegetable life. As the presence of this disease is supposed to be greatly connected with the prevalence of winds from the northern or easterly quarters, there is often a flea produced of a similar kind to that which attacks the shoots in their early growth. (6057.) It is highly injurious, by preying upon the nutriment of the blossoms, and thereby diminishing their weight and changing them to a brown colour, which is very prejudicial in their sale at the market.

6063. *The fire-blast* is a disease that hop-crops are exposed to in the later periods of their growth, and is generally supposed to proceed from the particular state of the air or weather. Others consider this disease as nothing more than the result of the attacks of the red spider. It has been conjectured to be the effect of lightning, as it takes place, for the most part, at those seasons when lightning is the most prevalent,

and in a very sudden manner : and besides the most forward and luxuriant vines are the most subject to be affected. It has been suggested, that in exposures where the crops are particularly liable to injury, it may be advisable to plant thinner, to keep back the growth of the plants as much as possible, by extirpating all the most forward shoots, and to employ a less proportion of the earthy compost in their culture.

6064. *In respect to the duty on hops*, it is best for the planter to have the acts before him. But every grower of hops in Britain is legally obliged to give notice to the excise, on or before the first day of September, of the number of acres he has in cultivation, the situation and number of his oasts, and the place or places of bagging, which, with the store-rooms, or warehouses, in which the packages are intended to be lodged, are entered by the revenue officer. No hops can be removed from the rooms thus entered, before they have been weighed and marked by a revenue officer ; who marks, or ought to mark, not only the weight, but the name and residence of the grower, upon each package.

SUBJECT. 2. *Culture of the Coriander and Caraway.* (fig. 804. a, b.)

6065. *The coriander* (*Coriándrum sativum* L., fig. 804. a) is a small-rooted annual, with branchy stems rising from one foot to one foot and a half in height. It is a native of the south of Europe, and appears to be naturalised in some parts of Essex, where it has been long cultivated. It flowers in June and July, and the seeds ripen in July and August.



6066. *The culture and management of coriander* consist in sowing it on a light rich soil in September, with seeds ripened the same year. Twenty pounds of seed will sow an acre. When the plants come up, thin them to six or eight inches' distance every way, and, next spring, stir the soil with a pronged hoe. In August the seed will be ripe, and if great care be not used, the largest and best part of it will be lost. To prevent this, women and children are employed to cut plant by plant, and to put them immediately into cloths, in which they are carried to some convenient part of the field, and there threshed upon a sail-cloth. A few strokes of the flail get the seeds clean out, and the threshers are ready for another bundle in a few minutes. In Essex it is sometimes cultivated with caraway and teazle. (See Caraway.)

6067. *The produce of coriander* is from ten to fourteen cwt. on an acre. It is used by the distillers for flavouring spirits, by the confectioners for encrusting with sugar, and

by the druggists for various purposes ; for all of which it is said to have a ready sale.

6068. *The caraway* (*Càrum Càruí*, b) is a biennial plant with a taper root, like a parsnep, but much smaller, running deep into the ground. The stems rise from eighteen inches to two feet, with spreading branches and finely cut deep green leaves. It is a native of England, in rich meadows in Lincolnshire and other places, and has been long cultivated in Essex. It flowers in May and June, and the seeds ripen in autumn.

6069. *The culture and management* are the same as those of coriander. In all probability both plants would answer if sown like clover among a crop of corn ; and hoed and thinned when the crop was removed, and again in the following spring. The method of culture in Essex is, about the beginning of March to plough some old pasture land : if it has been pasture for a century the better ; and the soil should be a very strong clayey loam. Twelve pounds of caraway seed are mixed with ten pounds of coriander, and twelve pounds of teasel seed : this is sufficient for one acre ; and is sowed directly after the plough, harrowing the land well. When the plants appear of sufficient strength to bear the hoe, which will not be until about ten weeks after sowing, it must not be omitted ; and in the course of the summer, the crop will require three hoeings, besides one at Michaelmas. The coriander being annual, will be fit to cut about the beginning of July. It is left in the field after cutting, and threshed on a cloth in the same manner as rape seed. About April following the caraway and teasel will want a good hoeing done deep and well ; and another about the beginning of June. The caraway will be fit to cut in the beginning of July, and must be threshed in the same manner as the coriander. This compound crop is mostly sown on land, so strong as to require being a little exhausted to make it fit for corn. Caraway and coriander are oftener sown without teasel : the latter being a troublesome and uncertain crop, and the produce of caraway much greater without it.

6070. *The produce of caraway*, on the very rich old leys in the hundreds or low lands of Essex, has often amounted to twenty cwt. an acre. There is always a demand for the seed in the London market.

6071. *The uses of the caraway* are the same as those of coriander, and its oil and other preparations are more used in medicine. Dr. Anderson says, both the roots and tops may be given to cattle in spring.

SUBJECT. 3. *Plants which may be substituted for Brewery and Distillery Plants.*

6072. *As substitutes for hops*, we may mention the common box (*Búxus sempervirens*), the leaves and twigs of which are said to be extensively used in all the beer brewed in Paris. The marsh trefoil (*Menyanthes trifoliata*) is much employed in Germany, and on the Continent generally ; and, it is said, was formerly used in this country. One ounce of the dried leaves is considered equivalent to half a pound of hops. The plant is of easy culture in moist soil : all the plants of the same natural order, *Gentiànea*, and especially the different species of *Gentiàna*, might be used in the same manner, more particularly the *G. lutea*, *rubra*, and *purpurea*. In Switzerland, a spirit is distilled from the roots of *G. lutea*. The dried roots of *Cèum urbànum*, common in hedges, are sliced,

enclosed in a thin linen bag, and suspended in the beer cask, by the brewers of Germany, to prevent, it is said, the beer from turning sour, and to give it the odour of cloves. (*Gard. Mag.* vol. vi. p. 148.) In Sweden, Norway, and the north of Scotland, the heath (*Erica L.*) and common broom were, and still are, occasionally used as substitutes for the hop. In some parts of France and Germany nothing else is used but broom tops. In Guernsey the *Teucrium Scorodonia* is used, and found to answer perfectly. In England, the different species of mugwort and wormwood have been used for that purpose; and the foreign bitter, quassia, a tree of Guiana, is still used by the porter brewers. Whoever has good malt, therefore, or roots, or sugar, and understands how to make them into beer, need be at no loss for bitters to make it keep.

6073. *Carminative seeds*, equal in strength to those of the caraway and coriander, are furnished by a very considerable number of native or hardy plants, and of flavours to which the drinkers of cordials and liqueurs are attached. Such are the fennels (*Fœniculum*) cultivated in Germany, parsley, myrrh, angelica, celery, carrot, parsnep, cow parsnep, and many other umbelliferous plants; avoiding, however, the hemlock, fool's parsley, æthusa, and some others which are poisonous. In Dantzic, where perhaps more seeds are used for flavouring spirits than any where else, several of the above and other plants are employed. Kümmel, their favourite flavour, is that of the cumin (*Cuminum Cyminum*), an annual plant, a native of Egypt, and cultivated in the south of Europe; but too tender for field culture in this country. But caraway or fennel seeds are very generally mixed with cumin, or even substituted for it in distilling kümmel-wasser.

SECT. III. *Oil Plants.*

6074. *In Britain there are few plants grown solely for the production of oil*; though oil is expressed from the seeds of several plants, grown for other purposes, as the flax, hemp, &c. Our chief oil plant is the rape.

6075. *Rape* is the *Brassica Napus L.*; *Navette*, Fr.; *Rübsamen*, Ger.; *Rapa silvatica*, Ital.; and *Naba silvestre*, Span. It is a biennial plant of the turnip kind, but with a caulescent or woody fusiform root scarcely fit to be eaten. Von Thaer considers the French and Flemish colza (*Kohlsaar*, Ger.) a different plant from our rape: colza is more of the cabbage kind, and distinguished by its cylindrical root, cut leaves, and greater hardiness. Decandolle seems to be of the same opinion.

6076. *Brassica campestris oleifera*, according to these writers, is the colsat or colza, or rape of the Continent, the most valuable plant to cultivate for oil; its produce being to that of the *Brassica Napus*, or British colsat or rape, as 955 to 700. It is distinguished from the *B. Napus* by the hispidity of its leaves. It would be desirable for agriculture, Decandolle observes, that, in all countries, cultivators would examine whether the plant they rear is the *B. campestris oleifera* or the *B. Napus oleifera*, which can easily be ascertained by observing whether the young plant is rough or smooth; if hispid, it is the *B. campestris*; if glabrous, the *B. Napus*. Experiments made by Gaujuc show the produce of the first, compared with that of the second, to be as 955 to 700. (*Hort. Trans.* v. 23.)

6077. *For its leaves as food for sheep, and its seed for the oil-manufacturer, rape, or coleseed*, has been cultivated from time immemorial. It is considered a native, flowers in May, and ripens its seeds in July. It may be sown broad-cast, or in rows, like the common turnip, or it may be transplanted like the Swedish turnip. The culture of rape for seed has been much objected to by some, on account of its supposed great exhaustion of the land; but where the soil and preparation are suitable, the after-culture properly attended to, and the straw and offal, instead of being burnt, as is the common practice, converted to the purposes of feeding and littering cattle, it may, in many instances, be the most proper and advantageous crop, that can be employed by the farmer.

6078. *The Culleys in Northumberland* used to cultivate rape on thin clays, as a preparation for wheat, of which they had valuable crops afterwards. The land, in the early part of the season, was prepared as for fallow, and the rape sown in June or July, and eaten off by sheep in September or October; after which the soil was once ploughed for wheat. The rape may also be sown among a crop of drilled winter beans in May.

6079. *The soils best suited for rape* are the deep, rich, dry, and kindly sorts; but, with plenty of manure and deep ploughing, it may be grown in others.

6080. *Young says*, that upon fen and peat soils and bogs, and black peaty low grounds, it thrives greatly, and especially on pared and burnt land, which is best suited to it; but it may be grown with perfect success on fenny, marshy, and other coarse waste lands, that have been long under grass, when broken up and properly prepared. As a first crop on such descriptions of land, it is often the best that can be employed. The author of *The New Farmer's Calendar* thinks that this plant is not perhaps worth attention on any but rich and deep soils; for instance, those luxuriant slips that are found by the sea-side, fens, or newly broken up grounds, where vast crops of it may be raised.

6081. *The preparation of old grass lands*, if not pared and burned, need be nothing more than a deep ploughing and sufficient harrowing to bring the surface to a fine mould; and this operation should not be commenced in winter, because the grub and wire-worm would have time to rise to the surface; but in February or March, immediately before sowing, or in July, or after the hay crop is removed, if the sowing is deferred till that season. When sown on old tillage lands, the preparation is pretty much the same as that usually given for the common turnip: the land being ploughed over four or five times, according to its condition, as a fine state of pulverisation or tilth is requisite for the perfect growth of the crop. In this view, the first ploughing is mostly given in the autumn, that the soil may be exposed to the influence of the atmosphere till the early part of the spring, when it should be again turned over twice, at proper intervals of time; and towards the beginning and middle of June one or two additional ploughings should be performed upon it, in order that it may be in a fine mellow condition for the reception of the seed.

6082. *In a rotation of crops*, the place which rape occupies is commonly between two of the culmiferous kind. On rich soils it may be succeeded to the greatest advantage by wheat, as it is found to be an excellent preparation for that sort of grain; and by its being taken off early, there is sufficient time allowed for getting the land in order for sowing wheat.

6083. *The season for sowing rape* is the same as that for the common turnip, and the manner, whether in broad-cast or rows, the same.

6084. *The row method* on the flat surface seems the best for newly broken up lands; and the rows on ridglets, with or without manure, the best for lands that have been under the plough. Where the object is the keep of sheep in autumn or winter by eating it down, the broad-cast method and thick sowing are evidently the best, and are generally resorted to in Lincolnshire and the fenny districts. The quantity of seed when sown thick may be a peck an acre; but when drilled or sown thin, two or three pounds will suffice. The seed should be fresh, black, and plump. Vacancies may always be filled up by transplanting.

6085. *The season of transplanting* begins as soon after the corn harvest as possible, being generally performed on the stubble of some description of corn crop.

6086. *One deep ploughing*, and a degree of harrowing sufficient to pulverise the surface, are given; and the plants may be dibbled in in rows a foot apart, and six inches in the row or narrower, according to the lateness of the season of planting, and the quality of the soil; for it must be considered that plants transplanted so late as September or October will be far from being so strong in the succeeding spring, as those sown in June and left where they are to run. The seed-bed from which the plants are obtained should have been sown in the June or July preceding the transplanting season, and may be merely a ridge or two in the same or in an adjoining field. We have already noticed (464.) the Flemish mode of transplanting, by laying the plants in the furrow in the course of ploughing; but as the plants cannot be properly firmed at the lower part of the root, we cannot recommend it.

6087. *The after-culture of rape* is the same as that of the turnip, and consists in hoeing and thinning.

6088. *The plants on the poorer soils* may be left at six or eight inches apart or narrower, but on the rich they may be thinned to twelve or fifteen inches with advantage to the seed. Few are likely to grow the plant on ridglets with manure; but, if this were done, the same distance as for turnips will ensure a better crop of seed than if the plants were closer together. In close crops the seed is only found on the summits of the plants; in wide ones on rich soils, it also covers their sides. When rape seed is grown purposely for sheep keep, no hoeing, thinning, or weeding, are necessary. Rape grown for seed will not be much injured by a very slight cropping from sheep early in the autumn, but considerably so by being eaten down in winter, or in the succeeding spring. The seed begins to ripen in the last week in June, and must then be protected as much as possible from birds.

6089. *In harvesting rape* great care is requisite not to lose the seed by shaking, chaffing, or exposure to high winds or rains.

6090. *It is reaped with the hook*, and the principal point is to make good use of fine weather; for, as it must be threshed as fast as reaped, or at least without being housed or stacked like other crops, it requires a greater number of hands in proportion to the land, than any other plant. The reaping is very delicate work; for if the men are not careful, they will shed much of the seed. Moving it to the threshing-floor is another work requiring attention. One way is to make little waggons on four wheels with poles, and cloths strained over them; the diameter of the wheels being about two feet, and the cloth body five feet wide, six long, and two deep; these are drawn by one horse, and the whole expense is not more than 30s. or 40s. In large farms, several of these may be seen at work at a time in one field. The rape is lifted from the ground gently, dropped at once into these machines without any loss, and carried to the threshers, who keep hard at work, being supplied from the waggons as fast as they come, by one set of men, and their straw moved off the floor by another set. Many hands of all sorts being employed, a great breadth of land is finished in a day. Some use sledges prepared in the same way. All is liable to be stopped by rain, and the crop much damaged; it is, therefore, of very great consequence to employ as many people as possible, men, women, and boys, to make the greatest use of fine weather. The seed is likewise sometimes cleaned in the field, and put into sacks for the market. But when large quantities of seed are brought quickly together, as they are liable to heat and become mouldy, it may be a better method to spread them out thinly over a barn, granary, or other floor, and turn them as often as may be necessary.

6091. *The produce* where the plant succeeds well, and the season is favourable for securing the seed, amounts to forty or fifty bushels or more on the acre. Marshal thinks, indeed, that on the whole it may be considered as one of the most profitable crops in husbandry. There have been, says he, instances, on cold, unproductive, old pasture-lands, in which the produce of the rape crop has been equal to the purchase value of the land. The seed is sold by the last of ten quarters, for the purpose of having oil expressed from it in mills constructed for that purpose. The price, like that of all crops of uncertain and irregular demand, is continually varying.

6092. *The uses* to which the rape is applied are the following:—

6093. *The use of the seed* for crushing for oil is well known; it is also employed as food for tame birds, and sometimes it is sown by gardeners, in the same way as mustard and cress, for early salading.

6094. *The rape-cake and rape-dust*, the former adhering masses of seed husks, after the oil has been expressed, and the latter loose dry husks, are used as a top-dressing for crops of different kinds. They are reduced to powder by a malt mill or other grinding machine, and sometimes sown broad-cast over young clovers, wheats, &c., and at other times drilled along with turnip seed. Four hundred weight of powder sown with turnip seed will go over one acre in drills, but three times the quantity is required for an acre sown broad-cast. Experience has proved, that the success of this manure depends in a great measure on the following season. If rain happens to fall soon after the rape-dust is applied, the crop is generally abundant; but if no rain falls for a considerable period the effects of this manure are little discernible, either on the immediate crop or on those which succeed it. There are turnip drills contrived so as to deposit the manure along with the seed.

6095. *The use of the haulm* to cattle in winter is very considerable. The *stover* (pods and points broken off in threshing) is as acceptable as hay, and the tops are eaten nearly as greedily as cut straw, and are at least better than wheat straw. When well got, the smaller stalks will be eaten up clean. The offal makes excellent litter for the farm-yard, and is useful for the bottoms of mows, stacks, &c. The haulm of this plant is frequently burned; and, in some places, the ashes, which are equal to potash, are sold; by which practice, if no manure is substituted, the soil must be greatly deteriorated. It is a custom in Lincolnshire,

sometimes to lay lands down with cole, under which the grass seeds are found to grow well. But this sort of crop, as already observed, is most suited to freshly broken-up or burned lands, or to succeed early peas, or such other green crops as are mowed for soiling cattle.

6096. *The leaves* as a green food for sheep are scarcely surpassed by any other vegetable, in nutritious properties, and in being agreeable to the taste of the animals; but in quantity of produce, it is inferior to both turnips and cabbages. The crops are fed off occasionally from the beginning of November to the middle of April: being found of great value, in the first period, for fattening dry ewes, and all sorts of old sheep; and, in the latter, for supporting ewes and lambs. The sheep are folded upon them in the manner practised for turnips, in which way they are found to pay from 50s. to 60s. the acre; that quantity being sufficient for the support of ten sheep, for ten or twelve weeks, or longer, according to circumstances. Rape has been found, by experience, to be superior to turnips in fattening sheep, and in some cases, even to be apt to destroy them by its fattening quality. In *The Corrected Report of Lincolnshire* it is likewise observed, that rapè grown on fresh land has the stem as brittle as glass, and is superior to every other kind of food in fattening sheep; while that produced on old tillage land has the stem tough and wiry, and containing comparatively little nourishment.

6097. *The Sésamum orientale* (*Sésame*, Fr.; *Sesamo*, Ital.), Bignoniàceæ, is cultivated in Italy for its seeds, which are eaten roasted like those of maize, boiled like those of the millet, made into a coarse flour like those of the beech or buck wheat, but principally bruised for an oil used as a substitute for butter.

6098. Among other plants which may be cultivated by the British farmer as oil plants, may be mentioned all the species of the *Brássica* family, the *Sinàpis* or mustard family, and the *Ráphanus* or radish family, with many others of the natural order of *Crucíferæ*. The seeds of these plants, when they remain too long on the seedsman's hands for growing, are sold either for crushing for oil, or grinding with mustard seed. This includes a good deal of wild charlock and wild mustard seed, which is separated in the process of cleaning grain by the farmers among whose corn these plants abound, and sold to the seed agents, who dispose of it to the oil or mustard millers. Various other *Crucíferæ*, as the *Mýagrum sativum*, *Ráphanus chinénsis* var. *olèifer*, both cultivated in Germany, the *Erýsimum*, *Sisýmbrium officinále*, *Turritis*, &c., might also be cultivated for both purposes.

6099. *The small or field poppy* (*Papàver Rhæas*; *Oilette*, Fr.), and also the *Maw seed* (*P. somníferum*, var. *Pavot*, Fr.), a variety of the garden poppy, are, as we have seen (467.), cultivated on the Continent as oil plants; the oil being esteemed in domestic economy next to that of the olive. Other species might be grown for the same purpose. All of them being annual plants require only to be sown on fine rich land in April; thinned out to six or eight inches' distance when they come up, according to the species; kept clear of weeds till they begin to run; and to have their capsules as they ripen gathered by hand and dried in the sun.

6100. *The sunflower* (*Heliánthus ánnuus*; *Turnesol*, Fr.; and *Girasole*, Ital.) has been cultivated in Germany for its seeds, which are found to yield a good table oil; its husks are nourishing food for cattle.

6101. *The Arachis hypogæa*, *Mýagrum sativum*, *Hésperis matronális*, *Ráphanus sativus olèifer*, and *Rícinus communis* are cultivated in France as oil plants.

SECT. IV. *Plants used in Domestic Economy.*

6102. Among agricultural plants used in domestic economy, we include the *Mustard*, *Buck-wheat* or *Beech-wheat*, *Cress*, *Tobacco*, *Chiccorry*, and a few others; with the exception of the first, they are grown to a very small extent in Britain, and therefore our account of them shall be proportionately concise.

SUBJECT. 1. *Mustard*. — *Sinàpis* L.; *Tetradynàmia Siliquòsa* L., and *Crucíferæ* J. *Moutarde* or *Sénévé*, Fr.; *Senf*, Ger.; *Senapa*, Ital.; and *Mostaza*, Span.

6103. There are two species of mustard in cultivation in the fields, the white mustard (*Sinàpis álba*, fig. 805. *a*), and the black or common (*Sinàpis nìgra*, *b*). Both are annuals, natives of Britain and most parts of Europe, and cultivated there and in China, for an unknown period. White mustard flowers in June, and ripens its seeds in July. Black mustard is rather earlier. Mustard is an exhausting crop, but profitable when the soil answers; and especially in breaking up rich loamy lands, as it comes off earlier, and allows time for preparing the soil for wheat. In breaking up very rich grass lands, three or four crops are sometimes taken in succession. It cannot, however, be considered as a good general crop for the farmer, even if there were a demand for it, as, like most of the commercial plants, it yields little or no manure. The culture of black or common mustard is by far the most extensive, and is chiefly carried on in the county of Durham. The seed of the black mustard, like that of the wild sort and also of the wild radish, if below the depth of three or four inches, will remain in the ground for ages without germinating: hence, when once introduced it is



difficult to extirpate. Whenever they throw the earth out of their ditches in the Isle of Ely, the bank comes up thick with mustard; and the seed, falling into the water and sinking to the bottom, will remain embalmed in the mud for ages without vegetation.

6104. *No such luxury as mustard*, in its present form, was known at our tables previously to 1720. At that time the seed was only coarsely pounded in a mortar, as coarsely separated from the integuments, and in that rough state prepared for use. In the year I have mentioned, it occurred to an old woman of the name of Clements, resident at Durham, to grind the seed in a mill, and to pass the meal through the several processes which are resorted to in making flour from wheat. The secret she kept for many years to herself, and, in the period of her exclusive possession of it, supplied the principal parts of the kingdom, and in particular the metropolis, with this article; and George I. stamped it with fashion by his approval. Mrs. Clements as regularly twice a year travelled to London, and to the principal towns throughout England, for orders, as any tradesman's rider of the present day; and the old lady contrived to pick up not only a decent pittance, but what was then thought a tolerable competence. From this woman's residing at Durham, it acquired the name of Durham mustard. (*Mech. Mag.* vol. iv. p. 87.)

6105. *Any rich loamy soil* will raise a crop of mustard, and no other preparation is required than that of a good deep ploughing and harrowing sufficient to raise a mould on the surface. The seeds may be sown broad-cast at the rate of one lippie per acre; harrowed in and guarded from birds till it comes up, and hoed and weeded before it begins to shoot. In Kent, according to the survey of Boys, white mustard is cultivated for the use of the seedsmen in London. In the tillage for it, the ploughed land is, he says, harrowed over, and then furrows are stricken about eleven or twelve inches apart, sowing the seed in the proportion of two or three gallons per acre in March. The crop is afterwards hoed and kept free from weeds.

6106. *Mustard is reaped in the beginning of September*, being tied in sheaves, and left three or four days on the stubble. It is then stacked in the field. It is remarked that rain damages it. A good crop is three or four quarters an acre; the price from 7s. to 20s. a bushel. Three or four crops are sometimes taken running, but this must in most cases be bad husbandry.

6107. *The use of the white mustard* is or should be chiefly for medical and horticultural purposes, though it is often ground into flour, and mixed with the black, which is much stronger, and far more difficult to free from its black husks. The black or common mustard is exclusively used for grinding into flour of mustard, and the black husk is separated by very delicate machinery.

6108. *The French either do not attempt to separate the husk*, or do not succeed in it, as their mustard when brought to table is always black. It is, however, more pungent than ours, because that quality resides chiefly in the husk. The constituents of mustard seed appear to be chiefly starch, mucus, a bland fixed oil, an acrid volatile oil, and an ammoniacal salt. The fresh powder, Dr. Cullen observes, shows little pungency; but when it has been moistened with vinegar and kept for a day, the essential oil is evolved, and it is then much more acrid.

6109. *The leaves of the mustard family*, like those of all the radish and *Brássica* tribe, are eaten green by cattle and sheep, and may be used as pot-herbs. The haulm is commonly burned; but is better employed as litter for the straw-yard, or for covering underdrains, if any happen to be forming at the time.

6110. *As substitutes for either the black or common mustard*, most of the *Cruciferae* enumerated when treating of oil plants (6098.) may be used, especially the *Sinàpis arvensis*, or charlock, *S. orientàlis*, chinensis, and *brassicata*, the latter commonly cultivated in China. The *Ráphanus Raphanístrum*, common in corn fields, and known as the wild mustard, is so complete a substitute, that it is often separated from the refuse corn and sold as Durham mustard seed.

SUBJECT. 2. *Buck-wheat.* — *Polygonum Fagopyrum* L.; *Octándria Trigýnia* L., and *Polygòneæ* J. *Blé noir* or *Blé Sarrazin*, Fr. (corrupted from Had-razin, *i. e.* red corn, Celtic); *Buchweizen*, Ger.; *Miglio*, Ital.; and *Trigo negro*, Span. (fig. 806.)



806

6111. *The buck-wheat*, or more properly beech-wheat (from the resemblance of the seeds to beech mast, as its Latin and German names import), is an annual fibrous-rooted plant, with upright flexuous leafy stems, generally tinged with red, and rising from a foot to three feet in height. The flowers are either white or tinged with red, and make a handsome appearance in July, and the seeds ripen in August and September. Its native country is unknown; though it is attributed to Asia. It is cultivated in China and other countries of the East as a bread corn, and has been grown from time immemorial in Britain, and most parts of Europe, as food for poultry and horses, and also to be ground into meal for domestic purposes. The universality of its culture is evidently owing to the little labour it requires: it will grow on the poorest soil, and produce a crop in the course of three or four months. It was cultivated as early as Gerard's time (1597), to be ploughed in as manure: but at present, from its inferior value as a grain, and its yielding very little haulm for fodder or manure, it is seldom grown but by gentlemen in their plantations to encourage game. Arthur Young, however, "recommends farmers in general to try this crop. Nineteen parishes out of twenty, through the kingdom, know it only by name. It has

numerous excellencies, perhaps as many to good farmers, as any other grain or pulse in use. It is of an enriching nature, having the quality of preparing for wheat, or any other crop. One bushel sows an acre of land well, which is but a fourth of the expense of seed-barley." Its principal value is not so much in the crop as in the great good it does the land by shading it from the heat of the sun. When the wheat fallow can be perfectly cleaned before the middle of June, it is far better to sow the ground with buck-wheat than let it be bare; the wheat crop, whether the dung be laid on before or after the buck-wheat, will be one third better than without it. (*J. M.*)

6112. *There are different species in cultivation, and P. tatáricum (fig. 807. a.) is said by some to be nearly as productive as P. Fagopÿrum. Von Thaer, however, is of a different opinion. In Nipal P. emarginátum (b) is cultivated. According to M. Decandolle, the farmers of Piedmont, especially in the valley of Lucerne, chiefly employ the P. tatáricum; because it ripens more quickly, and is therefore less likely to suffer from cold summers, or from being sown on the sides of the mountains. The Piedmontese distinguish the P. Fagopÿrum by the name of "Formentine de Savoie," and the P. tatáricum by that of "granette," and "Formentine de Luzerne." The principal objection to the latter is, that its flowers expand irregularly and unequally, and that the flour is blackish and rather bitter. The P. Fagopÿrum is, however, cultivated in the richest parts of Europe as a food for domestic fowls or other birds, rather than for the use of man. Cakes made of the flour of this species, we are told by Thunberg, round, coloured, and baked, are sold in every inn in Japan. Loureiro states, that P. odorátum is cultivated throughout the kingdom of Cochin China, as an excellent vegetable for eating with broiled meat and fish. (Bot. Reg.)*



6113. *In the culture of the buck-wheat the soil may be prepared in different ways, according to the intention*

of the future crop; and for this there is time till the end of May, if seed is the object, and till June if it is to be ploughed in. It will grow on any soil, but will only produce a good crop on one that is tolerably rich. It is considered one of the best crops to sow along with grass seed; and yet (however inconsistent) Arthur Young endeavours to prove that buck-wheat, from the closeness of its growth at the top, smothers and destroys weeds, whilst clover and grass-seeds receive considerable benefit by the shade it affords them from the piercing heat of the sun!!

6114. *The season of sowing cannot be considered earlier than the last week of April or first of May, as the young plants are very apt to be destroyed by frost. The mode is always broad-cast, and the quantity of seed a bushel per acre; it is harrowed in, and requires no other culture than pulling out the larger weeds, and guarding from birds till the reaping season.*

6115. *Buck-wheat is harvested by mowing in the manner of barley. After it is mown, it must lie several days, till the stalks are withered, before it is housed. It is in no danger of the seeds falling, nor does it suffer much by wet. From its great succulency it is liable to heat, on which account it is better to put it in small stacks of five or six loads each, than in either a large one or a barn.*

6116. *The produce of the grain of this plant, though it has been known to yield seven quarters an acre, may be stated upon the average at between three and four; it would be considerably more did all the grains ripen together, but that never appears to be the case, as some parts of the same plant will be in flower, whilst others have perfected their seed.*

6117. *The use of the grain of buck-wheat in this country is almost entirely for feeding poultry, pigeons, and swine. It may also be given to horses, which are said to thrive well on it; but the author of The New Farmer's Calendar says, he thinks he has seen it produce a stupefying effect.*

6118. *It has been used in the distillery in England; and it is a good deal used in that way, and also as horse-corn, on the Continent. Young says, a bushel goes farther than two bushels of oats; and mixed with at least four times as much bran, will be full feed for any horse for a week. Four bushels of the meal, put up at 4cwt. will fatten a hog of sixteen or twenty stone in three weeks, giving him afterwards three bushels of Indian corn or hog-peas broken in a mill, with plenty of water. Eight bushels of buck-wheat meal will go as far as twelve bushels of barley meal.*

6119. *The meal of buck-wheat is made into thin cakes called crumpits in Italy, and even in some parts of England; and it is supposed to be nutritious, and not apt to turn acid upon the stomach. (Withering.)*

6120. *The blossoms of this plant afford a rich repast to bees, both from the quantity of honey they contain, and from their long duration. On this account it is much prized in France and Germany, and Du Hamel advises bee farmers to carry their hives to fields of this crop in the autumn, as well as to heath lands.*

6121. *The haulm* of buck-wheat is said to be more nourishing than clover when cut while in flower. Banister says, it has a peculiar inebriating quality. He has seen hogs, after having fed heartily on it, come home in such a state of intoxication as to be unable to walk without reeling. The dried haulm is not eaten readily by any description of animal, and affords but very little manure. On the whole, the crop is of most value when ploughed in green for the latter purpose.

6122. *As a seed crop*, the author of *The New Farmer's Calendar* seems justified in saying, it is only valuable on land that will grow nothing else.

SUBJECT. 3. *Tobacco*. — *Nicotiana L.*; *Pentándria Monogýnia L.*, and *Solàneæ J.* *Le Tabac*, Fr.; *der Tabak*, Ger.; *Tabacco*, Ital.; *Tabaco*, Span.; and *Petum* or *Petume*, Brasil.

6123. *The species cultivated* are annuals, natives of Mexico, or other parts of America, and, according to some, of both hemispheres. It was brought to Europe early in the sixteenth century, after the discovery of America by Columbus, probably about 1519; from Portugal to France about 1560, by John Nicot, after whom the plant is named; and to England, according to Lobel, about 1570; according to Hume by Ralph Lane, in 1586, from the island of Tobacco in the Gulf of Mexico, whence the popular name.

6124. *The custom of smoking* is of unknown antiquity in Asia, Persia, and other eastern countries; but whether the plant used was tobacco is very doubtful. The natives of Mexico, in the present day, not only use it as an article of luxury, but as a remedy for all diseases, and, when provisions fail them, for allaying the pains of hunger and thirst. The use of smoking was introduced to England by Capt. Lane, who had learned the custom in Virginia, in 1586. He brought home with him several pipes and taught the custom to Sir Walter Raleigh, who soon acquired a taste for it, and began to teach it to his friends. He gave, we are told, "smoking parties" at his house at Islington, when the guests were treated with nothing but a pipe and a mug of ale and nutmeg. (*Biog. Brit.*) Down to the time of Elizabeth, it was not uncommon for ladies to smoke. During the reign of James her successor, most of the princes of Europe violently opposed its use. James of England wrote a book against it; the Grand Duke of Moscow forbade its entrance into his territory under pain of the knout for the first offence, and death for the next. The emperor of the Turks, the king of Persia, and pope Urban VIII., issued similar prohibitions, all of which were as ridiculous as those which attended the introduction of coffee, or Jesuit's bark. At present, all the sovereigns of Europe, and most of those of other parts of the world, derive a considerable part of their revenue from tobacco.

6125. *The cultivation of tobacco on the Continent* was not attempted, except in gardens, till the beginning of the seventeenth century. Under Louis XIII. and XIV., its cultivation was allowed in certain provinces of France; and about the same time it was introduced as an article of cottage or spade culture, in Holland, Germany, and part of Sweden. It also spread into Switzerland and Italy, and to various countries of the East. It is at present cultivated in almost every country of the world, but for commercial purposes chiefly on the Continent and islands of North America, and more especially in Virginia, Cuba, and St. Domingo. In no other parts of the world is it so well manufactured for the purpose of smoking as in Havanna.

6126. *In England* the practice of planting and growing tobacco began to creep in in the time of Charles II.; and an act was passed fixing a penalty of 10*l.* for every rood of land so cultivated, but making it lawful, however, to grow small quantities, not exceeding half a pole, "in a physic or university garden, or in any private garden for physic or chirurgery." This act and others were confirmed by different acts during the reign of Geo. III. Notwithstanding this act, however, tobacco was much cultivated a few years prior to 1782, in the vales of York and Ryedale. In the latter district it did not excite the notice of regal authority; and was cured and manufactured by a man who had formerly been employed upon the tobacco plantations in America; who not only cured it properly, but gave it the proper cut, and finally prepared it for the pipe. But in the vale of York the cultivators of it met with less favourable circumstances. Their tobacco was publicly burnt, and themselves severely fined and imprisoned. Penalties, it was said, were paid to the amount of 30,000*l.* This was enough to put a stop to the illegal cultivation of tobacco. But, perhaps rather unfortunately, it has likewise put a stop to the cultivation of that limited quantity of half a rood, which the law allows to be planted for the purpose of physic and chirurgery, or destroying insects.

6127. *In Scotland*, about the same time, tobacco was cultivated in various parts, more especially in the neighbourhood of Kelso and Jedburgh. Its produce was so great, that thirteen acres at Crailing fetched 104*l.*, at the low rate of 4*d.* per lb. (being 480 lbs. per acre), and would have brought more than three times as much, had not an act of parliament obliged the cultivator to dispose of it to government at that price. (*County Reports*.)

6128. *In Ireland*, tobacco was introduced into the county of Cork, with the potato, by Sir Walter Raleigh; but the culture of the former does not appear to have made much progress, though, according to Humboldt, it preceded that of the potato in Europe more than one hundred and twenty years, having been extensively cultivated in Portugal at the time that Sir Walter Raleigh brought it from Virginia to England in 1586. A writer in 1725, quoted by Brodigan, says, I have not heard that a rood of tobacco was ever planted in this kingdom. An act of George III. repealed several preceding acts, that prohibited the growth and produce of tobacco in Ireland; and this is the foundation on which Ireland now rests her claim to that branch of culture. Until the year 1828, Brodigan observes, the culture was limited; but in that year there were one hundred and thirty acres under tobacco; and in 1829, one thousand acres in Wexford alone. "It has been partially cultivated in the adjoining counties of Carlow, Waterford, and Kilkenny, and in other places. In the province of Connaught an experiment was made in the vicinity of Westport. It has been grown in one or two instances near Dublin; in the northern section of the kingdom two or three trials have taken place on a small scale;" and Mr. Brodigan, the author of the treatise from which we quote, has cultivated several acres in the neighbourhood of Drogheda, preparing the soil by horse labour as for turnips.

6129. *The restrictive system* will probably, at no distant time, be removed from tobacco, and from every other crop; but that tobacco ever will enter into the general course of crops of the British farmer, we do not think likely; because, when trade in this, as in every thing else, is once made free, the tobacco of warmer climates will unquestionably be preferred to that of the British isles. At present there is a number of gentlemen in the House of Commons who use tobacco; but should its use become unfashionable among the higher classes, we should not be surprised to see an attempt made to lay such a tax on the foreign commodity as would give the landed interest a monopoly of an inferior article, which would thus be forced by the rich on the poor. We trust, however, to the growing political sense of the country, to the force of opinion, in short, to the press, to avert such an evil. In the mean time, we ardently desire to see the culture of tobacco permitted and successfully attempted in Ireland, in order to aid in employing the population of that country; and we should wish also to see every cottager in the three kingdoms growing his half rood, which the law permits, and which, at a moderate calculation, ought to produce 4 lbs. of tobacco for his own smoking or snuff, or for selling to his neighbours. For this purpose we shall enter into the culture of tobacco at greater length than might otherwise be advisable.

6130. *The annual species of tobacco*, like the annual species of almost all dicotyledonous plants, may be grown in every country and climate; because every country has a summer, and that is the season of life for annual plants.

In hot, dry, and short summers, like those of the north of Russia and Sweden, tobacco plants will not attain a large size, but the tobacco produced will be of delicate quality and good flavour: in long, moist, and not very warm summers, such as those of Ireland, the plants will attain a very large size, perhaps as much so as in Virginia, but the tobacco produced will not have that superior flavour, which can only be given by abundance of clear sunshine, and free dry air. By a skilful manufacture, and probably by mixing the tobacco of cold countries with that of hot countries, by using different species, and perhaps by selecting particular varieties of the Virginian species, the defects in flavour arising from climate may, it is likely, be greatly remedied.

6131. *Species and varieties.* The species almost every where cultivated in America is the *N. Tabacum* (fig. 808.), or Virginian tobacco, of which there is a variety or sub-species known as *N. macrophylla*, but of which we have never seen any plants. *N. rustica* (fig. 809.), the common green tobacco (*fausse tabac* of the French, and *Bauern Tabac* of the Germans), is very generally cultivated almost to the exclusion of the other species in the north of Germany, Russia, and Sweden, where almost every cottager grows his own tobacco for smoking. It also seems to be the principal sort grown in Ireland. There is a variety of it cultivated in Wexford, erroneously denominated Oronooko, and another commonly called negro-head. Both are very hardy and very productive, but the produce is not of a very good flavour. There are other species grown in America; the best Havannah cigars are said to be made from the leaves of *N. repanda* (fig. 810. a), a species introduced to this country from Havannah so late as 1823. The Indians of the Rocky Mountains of North America are said to prepare their tobacco from *N. quadrivalvis* (fig. 810. b), introduced in 1811, and *N. mana* (fig. 810. c) introduced in 1823. These species are all annuals, and the last requires the protection of a green-house to make it ripen its seeds. There are several very distinct varieties, if not species, cultivated in the Caraccas, of which some account by Mr. Fanning, proprietor of the Botanic Garden of the Caraccas, will be found in the *Gardener's Magazine*, vol. vi. p. 327. There are also some other annual species, and some species of the genus *Petunia* which is nearly allied to the *Nicotiana*, the leaves of which might be manufactured into very good tobacco. There can be little doubt that the *N. Tabacum*, the seeds of which may be purchased in every seed-shop, is alone deserving the attention of the British cultivator, as a first experiment.

6132. *Soil.* In a strict sense, the native soil of the tobacco is unknown in this country; by which we mean the primitive earths or rocks to which it belongs. We are inclined to attribute it to alluvium and sand-stone rather than to clay or lime. In

808



(fig. 809.), the common green tobacco (*fausse tabac* of the French, and *Bauern Tabac* of the Germans),

809



10



Virginia the best tobacco is grown in a rich loamy, but rather light soil, which has been newly taken into cultivation. In Alsace, where we have seen stronger tobacco of the Virginian kind than in any other part of France or in Germany, the soil is a brown loam, rather light than heavy, such as would grow excellent potatoes and turnips, and which has been for an unknown period under the plough. Wherever potatoes or turnips may be cultivated, there we think tobacco may be grown.

6133. *Climate.* As it is beyond a doubt that the best tobacco is produced in countries within the tropics, it is evident that it cannot be worth culture in Britain in situations not naturally mild or warm. Tobacco can never be worth growing in situations much above the level of the sea, nor on wet springy soils or northern exposures.

6134. *Culture.* We shall notice in succession the practice in the West Indies, Virginia, and Maryland, in Alsatia, in Holland, in the South of France, and in Ireland, as lately practised by Mr. Brodigan, and suggest what we think the best mode. We shall draw our information chiefly from a valuable article in the *Nouveau Cours Complet d'Agriculture*, edition 1823, and from the treatise of T. Brodigan, Esq., 1830; looking into Carver's *Treatise on the Tobacco Plant*, 1779; Tatham's *Historical and Practical Essay*, 1800; Jennings's *Practical Treatise*, 1830; and our own notes of 1813-15, 18, 19, and 1828, on Sweden, Germany, and France.

6135. *Culture in the West Indies.* In the island of Tortuga, the tobacco seeds are sown in beds twelve feet square, and transplanted into the fields when about the size of young lettuces, in rows three feet apart, and the plants three feet distant in the row. The soil is hoed and kept clear of weeds, and the plant stopped when about a foot and a half high. The buds which push from the axillæ of the leaves are taken out with the finger and thumb, in order to throw the whole force of the plant into the leaves. When the edges and points of the leaves begin to get a little yellow, the stalks are cut over by the surface when the leaves are wholly freed from dew; they are then carried into a close house, so close as to shut out all air, and hung upon lines tied across for the purpose of drying. When the stalks begin to turn brownish, they are taken off the lines and put into a large bin or chest, and heavy weights laid on them for twelve days. They are then taken out, and the leaves stripped from the stalks, again put into the bin, and again well pressed, and completely excluded from air for a month. They are now taken out and tied into bundles, of about sixty leaves in each, which bundles are kept completely excluded from the air in a box or chest till wanted for disposal to the manufacturer. (*Dr. Barham, a contemporary of Sir Hans Sloan, in Jamaica, as quoted by Brodigan, p. 121.*) The species to which the above account refers, is, in all probability, the *N. repanda*.

6136. *Culture in Virginia and Maryland.* New soil of a medium quality is preferred: the seeds are mixed with six times their bulk of wood-ashes or sand, sown on beds of finely prepared earth, as early in spring as possible, and covered with straw, branches, or boards at nights when any danger is apprehended from frosts; they are of course kept clear of weeds. The field intended for the plants is in the mean time well laboured with the plough; it is laid into ridglets three feet wide, and along the centre of each a row of plants is placed by means of a line marked with knots, at three feet apart; the plants of the one row alternating with the intervals of the other; so that when the field is completed, the whole stand in quincunx. The plants are taken from the seed-bed to the field when they have five or six leaves exclusive of the seed leaf; but they may be transplanted with fewer or more leaves in moist or cloudy weather. They are taken up carefully, raising the earth under them with a spade, and carrying them to the field in a basket, and they are planted with dibbers an inch in diameter and fifteen inches long. They are inserted as deep as the seed leaf, but no deeper. In a month afterwards they will have grown a foot in height, and will require to be hoed and weeded. When they have attained the height of two feet, the summit of each plant is pinched out, and the lower small leaves, and any others dirtied or injured by insects, picked off. From eight to twelve good leaves may now remain on each plant. The remaining part of the culture consists chiefly in removing weeds or insects, and in pinching out the buds which appear in the joints or axillæ of the leaves. From the time that the tops of the plants are pinched off, till that when the crop is fit to be gathered, is generally about five or six weeks. During this time the plants are looked over two or three times every week, for the purpose of pinching off the lateral buds, so as to confine the entire effort of vegetation to the nourishing of the eight or twelve leaves. When the leaves begin to change colour, droop at the extremities, begin to smell rather more strongly, to become furrowed, rougher to the touch, and easily broken when bent, the plants are cut over by the surface when the dew is completely removed from them. Some cut them an inch under the surface, and others an inch above it. Each plant is left on the spot where it is cut for one day, and turned in the course of that day three or four times, to expose every part equally to get dried by the heat of the sun. Sometimes the plants are gathered into heaps, and remain on the field during the night in order to be spread out again the next day; but more generally they are collected together before the dew begins to fall, and put into a bin covered with boards on which stones are laid, and left in that situation, excluded from the air, for three or four days to ferment. Afterwards they are taken out, two and two tied together at the root end of the stem, or the same effect produced by running a peg through them, then hung across lines or cross-beams, and thus dried in open sheds. After the plants have been completely dried, they are taken down from the cords, poles, or beams, to which they have been attached, in a moist day; because if they were to be handled in a very dry day, the leaves would fall to pieces, or crumble into powder. They are now spread on hurdles in heaps, and covered with mats for a week or two to sweat: during this time the heap is frequently examined and turned, in order that every part may be equally heated and fermented, and no part burnt. This is said to be the most difficult part of the preparation, as it unquestionably is of the art of making hay; experience alone can teach its attainment. The fermentation being completed, the leaves are separated from the stems, the latter thrown away, and the former separated into three classes, bottom leaves, top leaves, and middle leaves. These leaves are now dried under cover, and tied together in bundles of ten or twelve, which are called manoques or hands; these are packed in regular layers into casks or boxes, and compressed so as to exclude all air by means of a round board of the same diameter as the interior of the cask, and which is every now and then put in and pressed down by means of a lever, which communicates a pressure of between 3000 and 4000 pounds. This manner of close packing is essential for the preservation of the tobacco. The operation is always performed when the air is humid, because, as before observed, dried tobacco is extremely brittle. Good tobacco thus prepared no longer ferments, except very slightly in the succeeding spring or summer, and which is found to be an advantage. The finest tobacco is grown in the west of Virginia and Maryland, near the Alleghany Mountains, where the temperature, during its growing season, is between 60° and 70°. (*N. Cours Complet d'Agr. &c.*) The species in this case is unquestionably *N. Tabacum*.

6137. *Culture of the tobacco in Holland.* The species is chiefly *N. Tabacum*, but sometimes *N. rustica*. The culture is carried to a considerable extent, especially in the provinces of Guelders and Utrecht. The seed is sown in hotbeds, ten feet broad, and of any convenient length; the depth of the dung of the bed is two feet, and the frame which is placed on it is sometimes covered with sashes, but more commonly with mats only during nights. The plants are transplanted into fields which receive a sort of garden culture.

The surface is laid out into beds or ridglets two feet and a half wide, with alleys between of nine inches or a foot. The beds are raised two feet above the alleys, and are composed of alternate layers of rich soil and dung rotten almost to mould. The direction of the bed is north and south, and on each two rows of plants are inserted at eighteen inches' distance between the rows, and at the same between plant and plant; the plants of one row alternating with the interstices of the others. The summer culture is the same as in Virginia, but the gathering of the crop is differently performed. When the leaves have shown the usual symptoms of maturity, the lowest, or those of the third quality, and the middle leaves, or those of the second quality, are stripped off and kept separate, and from four to six at top left on for some time longer. The leaves stripped off are separately dried, and in the mean time the plants watched, and every sucker or bud which makes its appearance pinched off. The top leaves, or those of the first quality, are gathered when ready; and all the remaining parts of the process with the three qualities is exactly the same as in Virginia. (*Ibid.*)

6138. *Culture in Alsatia*, and generally in the north and west of France and south of Germany. The seed, chiefly of *N. Tabacum*, is sown in March, or even earlier, in beds of fine mould in a garden, covered at night, and till it comes up, during day also, with straw mats. When it begins to come up, these are removed by nine o'clock in the morning, and put on again when the sun goes down. After the plants have produced their seed leaves, the straw mats are supported by hoops or rods, so as not to injure the plants. About the end of April, the plants will be found to have attained from two to four leaves, exclusive of their seed leaves; and from this time to the middle of June is considered the season for transplanting them into the fields. The best crops, other circumstances the same, are obtained from plants transplanted before the middle of May. Both in Holland and Alsatia, sheep's dung is found the best manure for the tobacco. The ground is made as fine as possible, not laid into ridges unless wet, and the plants are planted in rows, generally two feet and a half apart, and the plants alternating at the same distance in the row. Much of the value of the crop depends on the dryness and warmth of the summer, a good wine year being invariably a good tobacco year. In cold wet seasons many of the lower leaves become rusty or spotted; and though these do not always appear before the second fermentation, yet they ultimately become obvious by changing into holes after the last drying; their inferiority then becomes obvious to the purchaser. The top leaves alone are those used for manufacturing into snuff, and they bring much the highest price. These leaves generally remain on the plant till the twentieth of August; but the lower leaves are commonly gathered by the fifteenth of July. The tops of the plants are not generally pinched off till about the beginning of August, and they continue gathering leaves from that time till they are interrupted by white frost. Every eight days after the operation of topping, the side buds are pinched off. After the leaves are gathered, they are tied on the spot in bundles according to their qualities; and when they are taken to the drying shed, they are again separated and picked, and all those of one quality threaded together on lines, leaving a space about the width of a finger between each leaf. The lines thus charged with leaves are stretched from one side to the other of the drying shed, or lengthwise under the eaves of cottage roofs, which are made to project from one foot to three feet for the purpose of drying tobacco and maize. The more extensive growers have large sheds or barns on purpose, and these are always constructed with openings on all sides, so as to admit of the most perfect ventilation. When the air does not circulate freely among the leaves, instead of drying yellow they dry green or black, lose their grateful odour, and the midribs become rotten, and the whole leaf falls to pieces. Leaves which on the plant were most exposed to the sun and dews, such as the top leaves, always dry to the finest yellows. The leaves remain in the drying sheds till the weather has become decidedly cold in November or December, though some of the leaves of inferior qualities are frequently purchased for the manufacture of smoking tobacco in the month of October. But these must be immediately manufactured, otherwise when lying together they contract a bad smell. The threads of leaves being ready to take down, the leaves are not taken off the threads, but they are laid down in a humid mild day on a dry airy floor, one above another to the depth of from fourteen inches to half a foot. Here they lie for some time, being examined occasionally to see that they are not heating; if they heat, they are immediately hung up again; if they do not, they remain in that position till wanted by the manufacturer. Often, indeed, they are manufactured as soon as properly dried on the strings. (*Ibid.*)

6139. *The culture of tobacco in the south of France* is not materially different from what it is on the south banks of the Rhine. The tobacco of the south of France is naturally of a better quality; but the care taken of it by the cultivators, especially in the drying and fermenting, being less than in less favourable climates, the quality becomes reduced, so that the tobacco of Alsace is preferred to that of Garonne. The plants are cut over with all their leaves on as in Virginia, and they are hung up to dry in pairs across strings or beams. Being thoroughly dried, the leaves are separated, tied up in hands, and laid in heaps to ferment. These heaps are placed on boarded floors raised three or four inches above the surface of the soil; they are made two feet broad and two feet high, the width requiring exactly two hands, half of the one hand overlapping half of the other, and the ends or footstalks of the leaves of both being outwards. This operation is commonly performed between the fifteenth of November and the fifteenth of January, and the tobacco remains in that state till it is purchased by the manufacturer. The manufacturer having agreed for the price, makes up the hands into round balls of three or four hundred pounds weight; takes these home, unrolls them, separates the leaves, classes them according to their qualities, and finally puts them in hogsheads, packing them closely by means of presses. In these hogsheads the tobacco remains till taken out to be made into snuff, cigars, or common smoking tobacco.

6140. *The culture of tobacco in Ireland*, as practised by Brodigan in Meath, is thus given. Hotbeds like those made for cucumbers are to be prepared in March, and the seeds, Mr. Brodigan does not seem to have known what species he cultivated, sown any time from the fifteenth of that month to the first of April. In the beginning of May the plants may be hardened by exposure to the air, and by the fifteenth or twentieth of that month they may be transplanted into the open field without injury. Forty thousand plants fit for transplanting may be raised on an area of one hundred square feet. According to Carver, a square yard will rear about five hundred plants, and allow proper space for their nurture till they are fit for transplanting. The field was prepared in every respect the same as for turnips; the drills or ridglets were eighteen inches apart, and the manure, of which a good supply was given, buried in the centre of each ridglet. The plants were put in with spades, at eighteen inches apart, along the centre of the ridglet, and afterwards watered. "The planters were followed by women, with their aprons full of long grass, with which they covered each plant, and confined it by placing a stone or lump of earth at both ends; this covering is indispensable, unless the weather prove wet and cloudy. Such is the extreme delicacy of the plant, that it will not bear the heat of the sun, until it has so far set in the soil as to be able to supply the loss by evaporation. This will not be for some days, during which time the cover cannot be safely removed, and watering, to the extent of a pint a plant, may be daily used. Some of the respectable planters in the county of Wexford have used pots as a covering for the plants, of which some thousands will be necessary. Others have used large oyster shells, cabbage, or dock leaves. I tried all these methods, and experience has satisfied me that the mode I practised has decided advantages. It protects the plant sufficiently against the sun, and the water passes freely through it: whereas where pots or leaves are used, they must be removed to admit water, and in case of rain the plants receive little or no benefit from it. The operation of planting may be continued until the twentieth of June, but the earlier the better after the frosts have passed away. In America and France, I found, that four months were generally considered as necessary for the nutrition of the plants; and that time in this climate cannot be allowed, unless they are put down early." (p. 160.)

6141. *The summer management of tobacco*, by Mr. Brodigan, consisted in loosening the soil about the plants, removing the weeds, watering "for weeks together," taking off the decayed leaves at bottom, topping when the plant has from nine to fourteen good leaves, and removing the side buds as they appear.

6142. *The curing process, by Mr. Brodigan*, is as follows :—About the middle of August, the plants having attained their full size, four or five of the bottom leaves of each plant are taken off, “suffered to lie on the ground for some time; and when they lose their brittleness, and can be safely handled, they are carried home to a barn, and there put in a heap for fermentation. The heap is turned, placing that in the centre which was before in the bottom or exterior, and the temperature is not allowed to exceed 100° or 110°. After remaining two or three days in this heap, the leaves are spread out and cooled, and strung by the midrib on lines of packthread; they are then hung up in an airy shady place, roofed in. When the leaves thus suspended have acquired an auburn colour, they are fit for a second fermentation. “A quantity of hay must be placed between the tobacco and the ground, and the heap may be made of an oblong or conic figure, the end of the stems being placed inwards. The heap being made, it is to be surrounded with hay, blankets, or other close covering. The period for this fermentation will depend upon the state of the weather, and the dryness and size of the leaves. In four or five days I generally found the heat sufficiently high to penetrate and reduce the stems, and when that is accomplished the heap is to be cooled by spreading it out to dry. In reducing very strong tobacco, I found it necessary to permit the heat to ascend to 126°. In 60 hours I found the heat had attained 110°, and in 72 hours, 126°; but the general range of the second fermentation was from 120° to 125° Fahrenheit. In some cases I had to resort to a third fermentation of the same tobacco, but the heat did not rise beyond 90°. Upon this important point of fermentation, or sweating the tobacco, I have given the result of my practice. For greater accuracy, and the benefit of the inexperienced, I have given it from a thermometer; but, at the same time, the hand and feeling of a practised overseer can direct the process. As soon as the tobacco has been perfectly dried, by exposure to the sun and the weather, it is still necessary to dry any remaining moisture in the midribs, for which purpose they must be packed so as to be outside, that the air may have its influence upon them. When they are perfectly dry and hard, the tobacco may be considered as fit for use, although it will possess more or less of crudeness until the month of March following. To correct this crudity, or any acrimony that may exist, different preparations are used in different countries. In Brazil the leaves are steeped in a decoction of tobacco and gum copal. In Virginia, I understood, they sprinkle the tobacco, in the packing process, with diluted rum and molasses; and in Ireland they sprinkle, in the packing process, with a decoction of the green tobacco stems, or a decoction of hay, with a small portion of molasses: the effect of this innocent application is to soften and improve the flavour, darken the colour of the tobacco, and render it, in appearance, a more merchantable commodity. The next and last operation is to tie the leaves in hands, and pack them in bales or portable packages.” (p. 166.)

6143. *Improvements in the curing process.* Some of Mr. Brodigan’s tobacco, he informs us, only wanted age to be as good as Virginia. Tobacco improves by a sea voyage, as it undergoes a certain degree of fermentation in the hogsheads in the spring or summer months. Drying houses heated by flues or steam, as now erected in America, he thinks would be an improvement in Ireland. Captain Basil Hall visited a tobacco plantation on James River, and found the house in which the *hands* were hung up with fires of wood made upon the earthen floor. The flavour of the wood burnt in this way, Mr. Brodigan states, is now strongly perceptible in the tobacco of late years imported from America.

6144. *As suggestions* derived from considering what we have read and observed on the subject of cultivating and curing tobacco, we submit the following.

6145. *Where a farmer*, who thoroughly understands and successfully practises the Northumberland mode of cultivating turnips, intends growing tobacco as a field crop, we would recommend him to prepare the soil exactly as for Swedish turnips, give a double dose of well rotted manure, mix the seed with fifty times its bulk of sand or bone dust, and sow with Common’s turnip drill, usually called French’s, about the middle of May. When the plants come up, they may be thinned out as turnips are, to sixteen or eighteen inches apart, and topped in the beginning of August. The rest of the process may be conducted as in Alsace, drying, however, in a barn or house heated by an iron stove. A cottager, or spade cultivator, may find it worth his while to sow in a hotbed or in a flower pot, and transplant: he may dry his leaves the first time under the eaves of his cottage, and the second time in his garret; or if the quantity is small for home use, in his kitchen. For his tobacco liquor, or sauce, he may grow a score or two of poppy plants, collect the opium from them, and mix this with whisky or spirit of any kind, in which abundance of peach leaves, or a few leaves of *Laúrus nóbilis*, or one or two of the common laurel, have been infused, adding water and salt as directed above. A gardener, where there are hothouses and hothouse sheds, may dry and ferment in them; and indeed with such opportunities, and seeds of *N. repándum*, he ought to grow better tobacco than any person whatever not in Virginia or the West Indies.

6146. *Produce.* According to Morse (*American Geography*), “An industrious person in Maryland can manage 6000 plants, which, at a yard to each plant, cover considerably more than an English acre of ground:—the produce of these 6000 plants is 1000 lbs. of tobacco. ‘A hogshead,’ says Warden, ‘weighing 1350 lbs., is considered a good crop, and sufficient employment for one labourer. In general four plants will yield a pound, though very rich land will yield double the quantity. On the fresh, rich lands of Kentucky, from 1000 to 1500 lbs. are raised per acre.’” (*Brodigan*, p. 189.) The leaves of four plants in Virginia make one pound of tobacco. According to Brodigan, the average produce in the county of Wexford is 1200 lbs. per English acre. In Meath, he has had 1680 lbs. per English acre. The money cost of production he estimates at 18*l.* where the land is prepared by horse labour, and 30*l.* where it is prepared by manual labour, per English acre. The produce, at 16*l.* 8*s.* per hogshead of 1350 lbs., barely pays the expense.

6147. *To save seed.* Allow a few of the strongest plants to produce their flowers; they will have a fine appearance in July and August, and in a favourable season each plant will ripen as much seed in September as will sow a quarter of an acre by the drill system of culture, or stock half a dozen acres by transplanting.

6148. *The value of tobacco as an agricultural crop* is much diminished, from the circumstance of its producing no manure.

6149. “*The arguments of the immortal Jefferson* against the culture of tobacco, and in favour of wheat, have their weight in Virginia, where manure is not to be procured in proportion to the demand, and where the produce of that state has to enter into competition with that of the fresh lands of the western country. It is perfectly true, that where tobacco is generally cultivated, his picture of wretchedness is realised. It is the same in France, in the wine districts, where the people, from the want of corn, and the hogs, poultry, and other essential comforts it produces, are the most wretched of any in that country. It is with tobacco in America as with sugar in the West Indies, both are cultivated from their relative advantages over other crops. Sugar is more profitable than tobacco in the West Indies, although the tobacco grown there is of superior quality, and tobacco is preferred in America to wheat, where the soil and climate admit its cultivation. In some situations it is grown as a matter of necessity; such is the richness of their alluvial and fresh lands, that wheat cannot be produced until that excess of fertility is reduced by a course of

tobacco, maize, or hemp." (*Brodigan*, p. 84.) The farmers of Virginia, as the immortal Jefferson predicted (*Hist. of Virginia*), have now ascertained that it is better to raise wheat at one dollar a bushel than tobacco at eight dollars per hundred weight. (*Ibid.* p. 127.) As a source of labour, Mr. Brodigan thinks the culture and cure of tobacco a desirable employment for the rural population of Ireland. Its great advantage is that it affords employment for those intervals when the labouring poor are at present destitute of occupation. "The cultivation of a potato crop is of vital importance to the Irish peasant; but as soon as that crop is planted, there is a long interval of idleness and distress. The stock of potatoes is then generally exhausted or unfit for use, and the summer months are the most pinching times with the poor. The planting of tobacco may be said to commence when the other is furnished; and the field management occupies the interval until the corn-harvest. Again, between the corn-harvest and the taking up of the potatoes there is another interval of idleness, and that is occupied in the curing of the tobacco." (*Brodigan*, p. 178.) As a cleaning crop and a preparation for wheat, it must be at least equal to the potato.

6150. *The analysis of the tobacco stalk* is given by Mr. Brodigan on the authority of Mr. Davy of Dublin. The object was to ascertain whether the stalks contained any quantity of the tannin principle, of alkali, or of any useful vegetable substance.

6151. *The presence of the tannin principle* could not be detected; and the alkali afforded was not very considerable. One thousand parts of the stalks yielded fifty-eight of ashes, which afforded three parts and a quarter of alkali, mostly potash. The stalks contain nearly one tenth of their weight of tobacco; and where tobacco is employed either in fumigating or in making decoctions for the destruction of insects, it may be useful to know, that ten parts of the stalk will always produce effects equal to one part of the leaves.

6152. *Diseases and enemies.* "In Virginia, the diseases and injuries to which tobacco is liable, are, in the language of the planter, worm-holes, ripe-shot or sun-burnt, moon-burnt, house-burnt, stunted by growth, torn by storms of hail or wind, injured or killed by frost. In Ireland we are exempt from those damages, except what may arise from heavy gales, which, in exposed situations, lacerate and break off the leaves; or an early frost, which is seldom injurious before Michaelmas, at which time, if the planter be careful, he can have his tobacco off the ground." (*Brodigan*, p. 197.)

6153. *The same writer, however, enumerates the enemies of the tobacco in Ireland*, as "the red or ring worm, which is so destructive in some situations to wheat and corn crops, the grub, slug, caterpillar, and the tobacco-worm. Where the first two predominate in the soil, it is better not to plant tobacco; for there is no effectual mode of arresting their ravages. A correspondent in the county of Wexford has informed me, that two gentlemen in his neighbourhood attempted the planting of six acres of tobacco this last season, and the plants were no sooner put down than they were cut off by the red worm; they planted again, and the same fate attended them; they planted a third time, and they were a third time destroyed. Thus all their labour and expense were lost; and in the month of July, they sowed the ground with turnips. The grub, or rook-worm as it is called, marches from plant to plant beneath the soil, secure from observation; he attacks the roots of the plants when grown to a considerable height, and thus prostrates a whole field. Where numerous, it is in vain that you seek for the enemy; but as soon as the plant appears sickly, it is advisable to pull it up, and you are likely to meet a pair of grubs, as they are companionable travellers. The other enemies are visible, and not so destructive. The slug attacks the young plants in the seed-bed and in the field, and devours the young leaves: he will also cut the leaves of the tobacco in every stage of its growth, which is a proof that its caustic or poisonous property does not attach to it in the green state. The caterpillar generally appears in the warm month of July; it is large and of a voracious aspect. As soon as the leaves appear perforated, this enemy must be sought for, and he will be found in the day-time in the shaded parts of the plants. The caterpillar appears to exist only in close and warm situations." (*Brodigan*, p. 161.) Limewater or cow urine effectually destroys slugs, snails, and worms, and probably some of the sorts of caterpillars.

6154. *The manufacture of tobacco* we have slightly described in the *Encyclopædia of Plants*. We have since had an opportunity of witnessing the progress of all the different operations carried on in preparing shag and other kinds of smoking tobacco, pig-tail and other chewing tobacco, various snuffs, and different kinds of cigars, in one of the most extensive manufactories in London; and the conviction on our mind is, that very little in the way of manufacturing can be attempted by the gardener or cottager. That little we shall shortly describe.

6155. *The tobacco*, being properly fermented and cured, may be kept closely pressed and excluded from air, in casks, till wanted; or when the curing process is completed, smoking tobacco and snuff may be made from it as follows:—Open out the leaves singly, and from each tear out the midrib. The midribs are better adapted for rasping into snuff than for cutting into shag for smoking; and being scented by any essence, such as that of thyme, anise, lemon, or more especially by that of *Iris florentina*, the orris root of the druggists, may be tied up in what are called carrots, or rolls, about eighteen or twenty inches long, two or three inches in diameter in the middle, and half an inch at each end. They are tied with packthread drawn as tight as possible, and the threads quite close, so as to compress the tobacco into one solid substance, and completely to exclude the air. When snuff is wanted, unroll a part of the packthread at one end, and rasp the tobacco into snuff with a file or grater. The carrot may then be laid in a dry place till wanted for a fresh supply. The soft parts of the leaves may be treated in the same manner, and a snuff produced which some prefer to the other. Gardeners may dry leaves of any odoriferous plant, such as thyme, mint, *Aloysia citriodora*, &c., and tie them up in the tobacco carrot as substitutes for liquid scents; and, if thought necessary, they may add a leaf or two of *Veràtrum álbum* to add pungency. For cottagers, there are agrimony, wild thyme, and various other plants, which may be added. The soft parts of the leaves, from which the midribs have been removed, may be slightly sprinkled with water, without any admixture whatever, and twisted into a rope, about the thickness of a common straw rope. The rope may then be coiled up in a ball, as firmly and compactly as possible, tied round in two or three places with packthread, wrapped in paper, and placed in a dry situation, excluded from the air, till wanted for use. When to be used for smoking, cut off a few inches of the rope, open it out, and cut it into shreds with a knife or chopper, so that it may resemble shag tobacco. If it is to be made into snuff, open out the leaves, dry them over the fire or in an oven, and pound them in a mortar, adding to the powder any scented water, or volatile odoriferous oil, at pleasure. If more snuff is made than is wanted for immediate use, put it in a glass bottle, and cork it closely. In manufacturing snuff various matters are added to give it an agreeable scent, and hence its numerous varieties. The three principal kinds are rappees, Scotch, or Spanish, and thirds. The first is only granulated, the second is reduced to a very fine powder, and the third consists of the siftings of the second sort. The Scotch and Irish snuffs are, for the most part, made from the midribs; the Strasburgh, French, and Russian snuffs from the soft parts of the leaves.

6156. *The process of forming cigars* is very simple; but, as it cannot be done well without much practice, it would be of little use to offer a description. Whoever wishes to make himself master of all that is known on the culture of tobacco in different parts of the world, and all the different modes of its manufac-

ture, may consult *Cours d'Agriculture Complet*, Paris, 8vo, edit. 1823, art. Tabac; Carver's *Treatise*, London, 8vo, 1779; Tatham's *Essay*, London, 8vo, 1800; the *Experienced Bremen Cigar Maker*, or fundamental and practical instructions for making twenty-five sorts of cigars according to the latest experience, Chemnitz, Kretschmar, 1824, 8vo; Schmidt's *Tobacco Culture of the French and Dutch combined*, with the Mode of preparing the Plant for Use. Dresden, 8vo, 1824. Arndt. The two latter works are in German.

SUBJECT. 4. *Other Plants used in Domestic Economy, which are or may be cultivated in the Fields.*

6157. *Many garden plants might be cultivated in the fields, especially near large towns, where manure is easily procured, and a demand for the produce exists. Among such plants may be mentioned the cress, parsley, onion, leek, lettuce, radish, &c. There are also some plants that enter into the agriculture of foreign countries where the climate is not dissimilar to our own, which might be very effectually cultivated in this country were it desirable. Among these is the chiccory, the roots of which are used as a substitute for coffee. The lettuce might be grown for its milky juice, as a substitute for, or rather a variety of opium. Of dwarf fruits, as the strawberry, currant, gooseberry, raspberry, &c., we add nothing here, having already alluded to them in treating of orchards.*

6158. *The agriculturist who attempts to grow any of the above plants can hardly expect to succeed unless his knowledge extends beyond the mere routine of country husbandry, either by reading and the study of the nature of vegetables, or by some experience in the practice of gardening. No farmer on a moderately extensive scale will find it worth while to attempt such productions, whatever may be his knowledge or resources; and for the garden-farmer, or the curious or speculative amateur, we would recommend observation and enquiry round the metropolis, and the reading of books on horticulture. All that we shall do here, will be to give some explanation of the culture and management of cress and chiccory.*

6159. *The garden cress (*Lepidium sativum* L.), too well known to require any description, is grown in the fields in Essex, the seed being in some demand in the London market.*

6160. *It is sown on any sort of soil, but strong loam is the most productive. After being well pulverised on the surface, the seed is sown broad-cast and lightly harrowed in. The season of sowing for the largest produce is March, but it will ripen if sown the first week in May. The quantity of seed to an acre varies from two to four pecks, according to the richness of the land; the seed will not grow the second year. No after-culture is required but weeding. The crop is reaped and left in handfuls to dry for a few days, and then threshed out like rapeseed or mustard in the field.*

6161. *The use of the cress seed is chiefly for sowing to cut for young turkeys; and for forcing salads by the London cooks on hot moist flannels and porous earthenware vessels. A very considerable quantity is also used in horticulture, it being one of the chief early salads, and cut when in the seed leaf. The haulm is of very little use as litter, and, on the whole, the crop is exhausting.*

6162. *The culture of the chiccory as an herbage plant has already been given (5514.); when grown for the root to be used as a substitute for coffee, it may be sown on the same soil as the carrot, and thinned out to the same distance as that plant.*

6163. *These roots are taken up in the first autumn after sowing in the same manner as those of the carrot. When they are to be manufactured on a large scale, they are partially dried, and in that state sold to the manufacturers of the article, who wash them, cut them in pieces, roast them on a kiln, and grind them between fluted rollers into a powder, which is packed up in papers, containing from two ounces to three or four pounds. In that state it is sold either as a substitute for coffee, or for mixing with it. But when a private family cultivates this plant for home manufacture, the roots are laid in a cellar among sand, and a few taken out as wanted, washed, cut into slices, roasted in the coffee roaster till they become of a brown colour, and then passed as wanted through the coffee mill.*

6164. *The value of the chiccory as a coffee plant, Von Thaer observes in 1810, is proved by its having been cultivated for that purpose for thirty years. Dr. Howison has written some curious papers on the subject in *The Caledonian Horticultural Memoirs* (vol. iv.), and both that gentleman and Dr. Duncan approve of its dietetic qualities. The former indeed says, he thinks it preferable to coffee, which may be a matter of taste, as some prefer the flavour of the powdered roots of dandelion to that of either coffee or chiccory. Dr. Duncan is of opinion that chiccory might be cultivated with great national advantages as a substitute for the exotic berry. (*Disco. to Caled. Hort. Soc.* 1820.) Bose says the decoction of chiccory roots is wholesome, but that it has nothing more belonging to it of coffee than the colour. He sees no objection to its use as a substitute, but deprecates as fraudulent its mixture with the powder of real coffee.*

6165. *The value of the chiccory as a salad plant appears to us not to be sufficiently appreciated in this country. Great quantities of the blanched leaves of chiccory are sold in the markets of the Netherlands very early in the spring, and supply a grateful salad long before lettuces are to be had. The roots are taken up on the approach of winter, and packed in cellars in alternate layers of sand, so as to form ridges with the crowns of the plants on the surface of the ridge. Here, if the frost be excluded, they soon send*

811



out leaves in such abundance as to afford a supply of salad during winter. If light is excluded, the leaves are perfectly blanched, and in this state are known under the name of *Barbe de Capucin*. On ship-board it is customary to use a barrel of sand with numerous holes (fig. 811.), or a hamper, for the same purpose. (*Gard. Mag.* vol. ii. and *Ency. of Gard.*)

6166. *The *Astragalus bæ'ticus* (fig. 812.), an annual distinguished by its triangular pods, a native of the south of Europe, is cultivated in Hungary (§ 630.), and in some parts of Germany, for the seeds as a substitute for coffee. The culture is the same as that of the common pea or tare.*

812



6167. In a former section (6055.) we have hinted that no farmer who cultivates the hop need be without a vegetable equal to asparagus, or fibre similar to that of flax to employ his servants in spinning; and from the foregoing observations it would seem that whoever has a garden may grow his own coffee and tobacco.

SECT. V. *Plants which are or may be grown in the Fields for Medicinal Purposes.*

6168. A number of medicinal plants were formerly grown in the fields; but vegetable drugs are now much less the fashion; a few powerful sorts are retained, which are either collected wild or are natives of other countries, and the rest of the pharmacopœia is chiefly made up of minerals. It may safely be affirmed that there are no plants belonging to this section which deserve the notice of the general farmer; but we have thought it desirable to notice a few sometimes grown by farming gardeners, and which may be considered as belonging almost equally to horticulture and agriculture, or as points of connection between the two arts. These are the saffron, liquorice, rhubarb, lavender, mints, chamomile, and thyme.

6169. *The saffron, or autumn crocus (Crœcus sativus L., fig. 813. a), is a bulbous-rooted*



perennial, which has been long cultivated in the south of Europe, and since Edward III.'s time in England, and chiefly at Saffron Walden in Essex. It was abundantly cultivated there, and in Cambridgeshire, Suffolk, and Herefordshire, in the beginning of the seventeenth century; but the quantity of land under this crop has been gradually lessening for the last century, and especially within the last fifty years, so that its culture is now almost entirely confined to a few parishes round Saffron Walden. (*Young's Essex.*) This is owing partly to the material being less in use than formerly, and partly to the large importations from the East, often, as Professor Martyn observes, adulterated with bastard saffron (*Carthamus tinctorius*) and marigolds (*Calendula officinalis*).

6170. *The bulbs of the saffron are planted on a prepared soil, not poor nor a very stiff clay, but, if possible, a hazel mould on chalk. They are planted in July, in rows six inches apart across the ridges, and at three inches' distance in the rows.*

6171. *The flowers, which are purple, and appear in September, are gathered, carried home, and the stigmas picked out, together with a portion of the style; these are dried on a kiln between layers of paper, and under the pressure of a thick board, to form the mass into cakes.*

6172. *The crop of an acre averages two pounds of dried cake after the first planting, and twenty-four pounds for the next two years. After the third crop the roots are taken up, divided, and replanted.*

6173. *The uses of saffron in medicine, domestic economy, and the arts, are various. It is detersive, resolvent, anodyne, cephalic, ophthalmic, &c.; but its use is not without danger; in large doses it promotes drowsiness, lethargy, vomiting, and delirium; even its smell is injurious, and has been known to produce syncope. It is used in sauces by the Spaniards and Poles; here and in France it enters into creams, biscuits, conserves, liquors, &c., and is used for colouring butter and cheese, and also by painters and dyers.*

6174. *The liquorice (Glycyrrhiza glabra L., fig. 813. b; Liquoritia officinalis H.B. 10493.) is a deep-rooting perennial, of the Leguminosæ, with herbaceous stems rising four or five feet high. It has long been much cultivated in Spain; and since Elizabeth's time has been grown in different parts of England.*

6175. *The soil for the liquorice should be a deep sandy loam, trenched by the spade or plough, or the aid of both, to two and a half or three feet in depth, and manured if necessary. The plants are procured from old plantations, and consist of the side roots, which have eyes or buds. In autumn, when a crop of liquorice is taken up for use, these may be taken off and laid in earth till spring, or they may be taken from a growing plantation as wanted for planting. The planting season may be either October or February and March. In general the latter months are preferred. The plants are dibbled in rows three feet apart, and from eighteen inches to two feet in the row, according to the richness of the soil. The after-culture consists in horse-hoeing and deep stirring, in weeding, and in cutting over and carrying away the haulm every autumn after it is completely withered. As the plants do not rise above a foot the first season, a crop of onions or beans is sometimes taken in the intervals. The plants must have three summers' growth, at the end of which the roots may be taken up by trenching over the ground. These are either immediately sold to the brewers' druggists, or to common druggists, or preserved in sand, like carrots or potatoes, till wanted for use. They are used in medicine and porter-brewing.*

6176. *The rhubarb* (*Rhèum palmatum* L., fig. 813. c) is a perennial, with thick oval roots which strike deep into the ground, large palmate leaves, and flower-stems six or eight feet high. Its leaves are the best of all the kinds of rhubarb for tarts. The Society of Arts exerted itself for many years to promote the culture of this plant, as did Dr. Hope of Edinburgh. It has accordingly been cultivated with success both in England and Scotland; though the quality of the root produced is considered by the faculty inferior to that of the Russia or Turkey rhubarb, as Professor Martyn thinks, an inferiority probably owing to the moisture of our climate, and the imperfect mode of drying.

6177. *In the culture* of this plant, if bulk of produce be the object, then a deep, rich, loamy sand should be chosen; but if flavour, then a dry, warm, somewhat calcareous sand. Prepare as for liquorice, and sow in patches of two or three seeds, in rows four feet apart, and the same distance in the rows. Transplanting from seed-beds may be adopted; but the roots are never so handsome and entire. As soon as the plants appear, leave only one in a place. The plants will now stand in the angles of squares of four feet to the side. The after-culture consists in horse-hoeing and deep stirring, both lengthwise and across; in ploughing in the same directions; in never letting the flower-stems rise higher than two feet, or show flowers or seed unless some is wanted for propagation; and in removing the decayed haulm every autumn. The plants, having stood three or four summers, may be taken up, and their main roots dried in a very slow manner by any of the following modes:—The common British mode of curing or drying the rhubarb, after cleaning the roots, is to cut them into sections, an inch or more in thickness, string them, and dry them in airy lofts, laundries, or kitchens, in a gradual manner. This has long been the practice of private gardeners who grow the root for their own use, and has also been adopted by cultivators for the druggists. The rhubarb is cured in Tartary by being thoroughly cleaned, the smaller branches cut off, and then cut transversely into pieces of a moderate size; these are placed on long tables or boards, and turned three or four times a day, that the yellow viscid juice may incorporate with the substance of the root. If this juice be suffered to run out, the roots become light and unserviceable; and if they be not cut within five or six days after they are dug up, they become soft and decay very speedily. Four or five days after they are cut, holes are made through them, and they are hung up to dry exposed to the air and wind, but sheltered from the sun. Thus, in about two months, the roots are completely dried, and arrive at their full perfection. The loss of weight in drying is very considerable; seven loads of green roots yielding only one small horse-load of perfectly dry rhubarb.

6178. *The Chinese in curing rhubarb*, after having cleaned the roots, by scraping off the outer bark, as well as the thin yellow membrane underneath, cut them in slices, an inch or two in thickness, and dry them on stone slabs, under which large fires are kindled. They keep continually turning these slices on the warm slabs; but as this operation is not sufficient to dry them thoroughly, they make a hole through them, and suspend them on lines, in a place exposed to the greatest heat of the sun, till they are in a condition to be preserved without danger of spoiling. A copious account of all the experiments made in Britain for the culture and curing of the rhubarb up to 1805, is given by Professor Martyn, in his edition of *Miller's Dictionary*, art. *Rhèum*; and of the Turkey, Russian, and Chinese rhubarb, in *Thomson's Dispensatory*, 2d edit. 1822, p. 469. It has been alleged of late, that the true medicinal rhubarb is not the *Rhèum palmatum* as hitherto supposed, but the *R. australe* (fig. 814.) This species appears to be peculiar to the great table lands of central Asia, between the latitudes of 31° and 40°, where it is found to flourish at an elevation of 11,000 feet above the level of the sea. Large quantities of the roots are annually collected for exportation in the Chinese provinces, within the lofty range of the Himalaya. The best is that which comes by way of Russia, as greater care is taken in the selection; and on its arrival at Kiachta, within the Russian frontiers, the roots are carefully examined, and the damaged pieces removed. Mr. Sweet has been informed that the stems of the leaves have the same effect as the root; only, of course, a greater portion of them will require to be used. They may be made up in a small tart, like the stems of the common rhubarb. (*Gard. Mag.* vol. v. p. 161.)

814



6179. *The lavender* (*Lavándula Spica* L. fig. 813. d) is a dwarf odoriferous shrub of three or four years' duration, grown in the fields in a few places round London, and chiefly in Surrey, for the spikes of flowers used by the druggists, perfumers, and distillers. The soil should be a poor dry calcareous gravel. The seeds should be sown in a garden in spring, and the plants may be transplanted in September or March following, in rows two feet apart, and kept free from weeds. The second season they will yield a few flowers, and a full crop the fourth, after which the plants will continue productive for five or six years. The spikes are gathered in June, dried in the shade, and sold in bundles to the herbalists, druggists, &c.

6180. *Thyme, wormwood, marjoram, savory*, and some other aromatics, are cultivated in the same manner, and for similar purposes. Being usually smaller plants, they should be planted closer; but to have much flavour the soil must be dry and calcareous.

6181. *Chamomile* (*Anthemis nobilis*) is a creeping perennial, grown for its flowers. It only requires to be planted on a poor soil, in rows a foot apart, and hoed between. It will produce abundance of flowers annually from June to September, which are gathered, and dried in the shade. They are sold by weight to the druggists and apothecaries. The double-flowered variety is, from its beauty, that commonly cultivated; but the single possesses more of the virtues of the plant according to its weight.

6182. *The mints* (*Méntha*), and especially the *peppermint* (*Méntha piperita*), are creeping-rooted perennials, cultivated on rich marshy or soft black moist soils for distilling. The plants are grown in beds with trenches of a foot or more in width and

depth between, so as to admit of irrigation. The sets are obtained from old plantations, and planted in rows across the beds at six inches' distance every way, in March or April. No produce worth notice is obtained in the first year, but a full crop in the third, and the shoots will continue to produce for five or six years. The spikes of flowers, and in some cases the entire herbage, are cut over in June, as soon as the flowers expand, and carried immediately to the druggist's still. Some growers distil it themselves.

6183. *The common valerian* (*Valeriana officinalis* L.) is sometimes cultivated for its roots for the druggists. It is a native plant, and prefers a loamy soil. In Derbyshire the plants, which are either procured from the offsets of former plantations, or from wild plants found in wet places in the neighbouring woods, are planted six inches asunder, in rows twelve inches apart. Soon after it comes up in the spring the tops are cut off, to prevent its running to seed, which would spoil it. At Michaelmas, the leaves are pulled and given to cattle, and the roots dug up carefully, and clean washed; the remaining top is then cut close off, and the thickest part slit down to facilitate their drying, which is effected on a kiln, after which they must be packed tight, and kept very dry, or they will spoil. The usual produce is about 18 cwt. per acre. This crop receives manure in the winter, and requires a great deal.

6184. *The orchis or salep plant* (*O'rchis mascula* L.) is a tuberous perennial, which grows plentifully in moist meadows in Gloucestershire, and other parts of the country. It flowers in May and ripens seeds in July. It has been proposed to cultivate it for its tubers to be used as salep; but the plant is very difficult of propagation from seed, and can hardly be multiplied at all by the root; and, though it may answer to collect the tubers and prepare them, it is not likely their culture will ever pay. As the plant is very abundant in some situations, it may be useful to know its preparation, which is thus described in *Phil. Trans.* vol. lix.

6185. *The bulb is to be washed in water*, and the fine brown skin which covers it is to be separated by means of a small brush, or by dipping the root in hot water, and rubbing it with a coarse linen cloth. When a sufficient number of bulbs are thus cleansed, they are to be spread on a tin plate, and placed in an oven heated to the usual degree, where they are to remain six or ten minutes, in which time they will have lost their milky whiteness, and acquired a transparency like horn, without any diminution of bulk. Being arrived at this state, they are to be removed, in order to dry and harden in the air, which it will require several days to effect; or, by using a gentle heat, they may be finished in a few hours. By another process, the bulb is boiled in water, freed from the skin, and afterwards suspended in the air to dry; it thus gains the same appearance as the foreign salep, and does not grow moist or mouldy in wet weather, which those that have been barely dried by heat are liable to do. Reduced into powder, they soften and dissolve in boiling water into a kind of mucilage, which may be diluted for use with a large quantity of water or milk. Thus prepared, they possess very nutritious qualities; and if not of the very same species as those brought from Turkey and used for making salep, they so nearly resemble them as to be little inferior. In Turkey the different species of the *O'rchis* are said to be taken indifferently; but in England, the *O'rchis mascula* is the most common. (*Gloucestershire Report*, 377.)

CHAP. IX.

Marine Plants used in Agriculture.

6186. *All marine plants may be used as manure* with great advantage, either in a recent state or mixed with earth. It is used in this way more or less in all agricultural countries bordering on the sea, and in Britain in all those friths and estuaries, where, from the water not being at the maximum of saltness, the plants which grow in it are not sufficiently charged with soda to render it worth while to burn them for the sake of the salt.

6187. *The use of sea-weed*, as an article from which kelp might be manufactured, seems to have been practically recognised in Scotland about the beginning of the eighteenth century. The great demand for kelp in the manufacture of glass and soap at Newcastle, and of alum at Whitby, seems to have introduced the making of this commodity upon the shores of the Forth, so early as about the year 1720. It began to be manufactured in the Orkney Islands in the year 1723, but in the western shires of Scotland the making of kelp was not known for many years after this date. The great progress of the bleaching of linen cloth in Ireland, first gave rise to the manufacture of kelp in that kingdom; and from Ireland it was transferred to the Hebrides about the middle of the eighteenth century. On the shores of England the kelp plants are not abundant.

6188. *All marine plants may be used for the manufacture of kelp*, but the principal species in use on the British shores belong to the Linnean genus *Fucus*. *Fucus vesiculosus* (*fig.* 815. *a*) is considered by kelp-makers as the most productive; and the kelp obtained is, in general, supposed to be of the best quality. *Fucus nodosus* (*b*) is considered to afford a kelp of equal value to that of the above species, though perhaps it is not quite so productive. *Fucus serratus* (*c*), or black-weed, as it is commonly called, is neither so productive as the preceding, nor is the kelp procured from it so valuable. This weed is seldom employed alone for the manufacture of kelp; it is in general mixed with some of the other kinds. *Fucus digitatus* (*Laminaria digitata* *H. B.* 15, 343.) (*d*) is said to afford a kelp inferior in quality to that obtained from any of the others; it forms the principal part of the drift-weed.

6189. *The plants are cut in May, June, and July*, and exposed to the air on the ground till nearly dried, care being taken to prevent them, as much as possible, from being exposed to the rain. They are then

burned in a rude sort of kiln, formed by digging a pit in the sand, or by enclosing a portion of the surface with loose stones. On the bottom of this kiln a peat fire is kindled, and the weed is gradually added, till



the fire extends over the whole floor; the weed is then spread lightly on the top, and added in successive portions. As it burns it leaves ashes, which accumulating towards evening, become semifused, and are then well stirred. Another day's burning increases the mass; and this is continued till the kiln is nearly filled. On some occasions the kiln consists of a cavity in the ground, over which bars of iron are placed; and on this the ware is burned, the ashes falling into the cavity, where they are well worked by the proper instruments.

6190. *Kelp is generally divided into two kinds*; the cut-weed kelp, and the drift-weed kelp; the former made from the weed which has been recently cut from the rocks, the latter from that which has been drifted ashore. The latter is supposed to yield a kelp of inferior quality. Some specimens of kelp, however, made from sea-weed which had been drifted ashore, tend to prove that this is not always the case. Weed which has been exposed to rain during the process of drying, affords a kelp of inferior quality. It is of the utmost importance to the manufacturer of kelp, to keep his weed as much as possible free from rain. For this purpose many employ sheds; when these are not at hand, the weed which has been laid out to dry should be collected into one heap during the rain; when this ceases, it should again be immediately spread out. It has often been matter of dispute, how old the plants should be before they are cut. In general, three years is considered sufficient: this, however, from some trials which have been made to ascertain this point, seems to be too long. From experiments, it appears, that the produce of kelp, from one ton of three years' old weed, is only eight pounds more than that from the same quantity of two years' old; from this we would conclude, that the weed ought to be cut every two years. Though perhaps less weed may be procured from the same extent of ground occupied by weed of two, than of three years' growth, yet the difference may not be so great as to render it worth while to allow the weed to remain for three years.

6191. *In order to increase the quantity of kelp*, it has been suggested to the Highland Society, that the seed of the *Salsòla Sòda* might be imported and cultivated at a small distance from the shore, with the design of mixing the plant with the sea-ware, for the improvement of the kelp. It was formerly imagined, that the barilla plant would not produce any quantity of alkali, worth its cultivation, if planted in France; but in the year 1782, some spirited individuals procured a quantity of barilla seed, and made a plantation of it near the coast of the Mediterranean, in the province of Languedoc, and had the satisfaction for several years to find, that the barilla which they produced from these plants was of a quality equal to that which they usually procured from Alicant. Why, then, may not a similar attempt in our own country be equally successful?

6192. *Other plants.* If the growers of kelp could contrive to make some considerable plantations of the most productive of the kali, or of fumitory, wormwood, and other inland plants, which yield large quantities of potash, and collect the crop to burn with the other materials, the carbonate of potash resulting from their incineration would decompose the sea salt, and a great accumulation of carbonate of soda would be produced. It was proved long ago by Du Hamel, that the marine plants produced soda merely in consequence of their situation, for when they have been cultivated for some years in an inland spot they yield only potash.

6193. *There are immense tracts of shore on the mainland and islands of Scotland* which may be easily cultivated for the production of kelp, from which at present not one penny is derived. All the cultivation requisite is, to place whin or other hard stones, not under the size of the crown of a hat, upon such vacant spaces. Contracts have been made to plant shore lands in the Highlands with such stones, at the rate of 20*l.* per Scots acre. Such stones are generally to be found at high-water mark, on all the shores of the lochs of the Highlands. They are put into a boat at high water, then carried to the ground to be planted, and thrown overboard; on the ebb of the tide they are distributed regularly over the shore, preserving a clear space of one foot round every stone, which distance, after very minute examination, appears to be the most eligible for producing the greatest crop of ware. It is evident these stones should be of a round shape; as the more surface that is exposed to the alternate action of the air and water, so much more kelp ware will be produced from a given space of ground. In four years the first crop may be cut, which, on the above data will yield about four per cent on the original expense. But the crop may be manufactured into kelp in every third year thereafter, which, on the same data, is equal to about five per cent. In this improvement there is no hazard of bad crops; and if the manufacture is begun early enough in the season, there is little danger to be apprehended from bad weather, it being understood that the operation of kelp-making can be carried on, should there be no more than two dry days in eight. (*Highland Society's Trans.* vols. v. and vi.)

6194. *The cultivation of barilla* (*Salsòla Sòda*, *Chenopòdeæ*, a native of Spain), on a small scale, was tried in the gardens of Tynningham, the seat of the Earl of Haddington, in 1789, but without success, although planted under a south wall, in a most sheltered part of the garden. (*J. M. in Gard. Mag.*) The culture of this and other species is practised to some extent in the neighbourhood of Alicant in Spain, and the details given

in the *Cours Complet*, &c. art. *Soude*. The ground is brought into good tilth, and manured; and the seed sown broadcast in October or November: in the following spring the plants will be found an inch high, and must be kept clear of weeds till the month of August, when, being at its full growth, it may be mown or pulled up (for it has scarcely any roots), dried, and afterwards burnt in holes in the ground like kelp.

6195. *The sea-wrack grass* (*Zostera marina*; *Fluviàles*) is found in abundance on different parts of our own shores, as at Yarmouth, the bays of the Orkney Islands, and other bays not exposed to the immediate fury of the ocean.

6196. *It grows in banks of sand and mud*, which banks appear to be held together principally by the roots of this plant, which are strong and succulent, and throw out numerous lateral fibres. It grows at such depths as to be left nearly dry by the ebbing of spring tides. During the autumn and beginning of winter these leaves are thrown on shore in large quantities. They are of a very imperishable nature, and may be kept for any length of time in fresh or salt water, without any apparent decay. In the Orkney Islands this grass is thrown ashore during winter in large quantities, and collected by the inhabitants with other marine plants into heaps, for manure. In these heaps it is allowed to ferment, and sometimes, before being applied, it is mixed with earth or other matters. It is also used as thatch, and forms a more durable defence against the violent winds and heavy rains of that climate than straw. A few years ago, in consequence of premiums offered by the Highland Society, this grass was applied as a substitute for horse-hair, and stuffing mattresses and furniture: for this purpose it is carefully washed twice in fresh water, then dried quickly; and afterwards, any sea-weed that had got mixed with it picked out. In the Orkneys it is steeped in fresh-water lakes for a week, then taken out and spread wet on the ground, and picked, while in this state, from extraneous matters. Exposure to drought for one day will make it sufficiently dry for packing. When dry, care must be taken, if the weather is windy, to gather it into heaps or cocks, otherwise it may be blown away, being then extremely light. It is sent to market in large bags of sacking, or twisted into ropes of the thickness of a man's waist, and then compactly made up in nets, formed of ropes made of bent grass. It is sold at the Asylum for the Industrious Blind at Edinburgh, who employ it in stuffing mattresses. (*Highl. Soc. Trans.* vol. vi. p. 592.)

CHAP. X.

Weeds or Plants injurious to those cultivated in Agriculture.

6197. *Every plant which appears where it is not wanted may be considered injurious*, though some are much more so than others. A stalk of barley in a field of oats is a weed, relatively to the latter crop, but a thistle is a weed in any crop; weeds, therefore, may be classed as relative and absolute.

6198. *Relative weeds*, or such cultivated plants as spring up where they are not wanted, give comparatively little trouble in extirpating them. The most numerous are the grasses when they spring up in fields of saintfoin or lucern, or among corn crops in newly broken up grass lands. The roots of chiccory, in fields that have been broken up after bearing that crop for some years, those of madder, liquorice, &c., are of difficult extirpation. When the potato crop has not been carefully gathered, or mustard has been allowed to shed its seed, they also occasion trouble. Other cases will readily occur to the practical man, and need not be mentioned.

6199. *Absolute weeds*, or such native plants as are considered injurious to all crops, are very numerous, and may be variously arranged. Some affect in a more peculiar manner corn-fields and tillage lands, and these are chiefly annuals, as wild mustard, wild radish, poppy, blue-bottle, cockle, darnel, &c.; or biennials, as the thistle; or perennials, as couch-grass, knot-grass, black-couch, polygonum, &c.; on lands laid down to grass for a few years, dock, ox-eye daisy, ragweed, &c. Others infest grass lands, and these are chiefly perennials, such as crowfoot, one of the most difficult of weeds to extirpate; thistles, docks, rushes, sedges, moss, and an endless variety of others. Some are more particularly abundant in hedges; of which the reedy and coarse grasses, as couch-grass, brome-grass; the climbing and twining plants, as goose-grass (*Galium Aparine*); and the twiners, as bind-weed (*Convólulus*), are the most injurious.

6200. *With regard to the destruction of weeds*, they may be classed first according to their duration.

6201. *All annuals and biennials*, as salad-wort (*fig. 816. a*), and sorrel (*b*), are effectually destroyed by cutting over the plant at any point below that whence the seed leaves originated, as this prevents them from ever springing again from the roots. Perennials of the fibrous-rooted kind may be destroyed in the same manner, as the crowfoot, ragweed, the fibrous-rooted grasses, and many others. Some fusiform-rooted perennials may also be destroyed by similar means; but almost all the thick-rooted perennials require to be wholly eradicated.

6202. *The perennial weeds*, which require their roots to be wholly eradicated, may be classed according to the kind of roots. The first we shall mention are the stoloniferous roots or surface shoots of plants, by which they propagate themselves. Of this kind are the creeping crowfoot, goosefoot or wild tansy, potentillas, mints, strawberries, black couch-grass, and most of the *Agrostidæ* and other grasses. The next are the under-ground creeping roots, as the couch-grass, *Convólulus arvensis*, and other species of bind-weed, coltsfoot (*fig. 816. c*), sowthistle, several tetradynamous plants, as toadflax, *Scrophularia*, nettle, hedge-nettle (*Stachys*), *Lamium*, *Ballota*, &c. Some of these, as the bindweed and corn-mint, are extremely difficult to eradicate: a single inch of stolone, if left in the ground, sending up a shoot and becoming a plant. The creeping and descending vivacious roots are the most difficult of all to eradicate. Of this class are the *Polygonum amphibium* (*fig. 817. a*), the reed (*Arundo Phragmites*), the horse-tail (*Equisetum*, *fig. 817. b*), and some others. These plants abound in deep clays, which have been deposited by water, as in the carses and clay-vales of Scotland. In the Carse of Falkirk for example, the roots of the *Polygonum amphibium* are found



every where in the subsoil alive and vigorous. They send up a few leaves every year in the furrows and on the sides of drains; and when any field is neglected or left a year or two in grass, they are found all



over its surface. Were this tract left to nature for a few years, it would soon be as completely covered with the *Polygonum* as it must have been at a former age, when it was one entire marsh partially covered by the Frith of Forth. The horse-tail is equally abundant in many soils, even of a drier description; and the corn-thistle (*Serratula arvensis*, fig. 817. c) even in dry rocky grounds. Lightfoot (*Flora Scòtica*) mentions plants of this species dug out of a quarry, the roots of which were nineteen feet in length: it would be useless to attempt eradicating the roots of such plants. The only means of keeping them under, is to cut off their tops or shoots as soon as they appear; for which purpose, lands subject to them are best kept in tillage. In grass lands, though they may be kept from rising high, yet they will, after being repeatedly mown, form a stool or stock of leaves on the surface, which will suffice to strengthen their roots, and greatly to injure the useful herbage plants and grasses.

6203. *Tuberous and bulbous-rooted weeds*, are not very numerous; wild garlic, arum, and bryony are examples; and these are only to be destroyed by complete eradication.

6204. *Ramose, fusiform, and similarly rooted perennials*, of which rest-harrow, fern, and scabious are examples, may in general be destroyed by cutting over below the collar or point whence the seed-leaves have issued. Below that point the great majority of plants, ligneous as well as herbaceous, have no power of sending up shoots; though there are many exceptions, such as the dock, burdock, &c., among herbs, and the thorn, elm, poplar, cherry, crab, &c., among trees.

6205. *Holdich* has taken a different view of the subject of weeds, and classed them, not according to the modes by which they may be destroyed, but according to the injuries which they do to the soil or the crop. He has divided them into two classes, weeds of agriculture, or arable lands, and pasture weeds.

6206. *Arable weeds* are arranged as, 1. those which infest samples of corn; 2. root or fallow weeds, and such others as are hard to destroy; 3. those which are principally objectionable as they incumber the soil; 4. underling weeds, such as never rise with the crop, nor come into the sickle. Under these heads, each weed in its respective division is treated of as to its deteriorating qualities and mode of destruction.

6207. *The weeds which infest the sample* are, 1. Darnel (*Lolium temulentum*); 2. Cockle (*Agrostemma Githago*); 3. Tares (*Ervum tetraspermum*); 4. Melilot (*Trifolium Melilotus officinalis*); 5. Wild oats (*Avena fatua*); 6. Hariff (*Galium Aparine*); 7. Crow needles (*Scandix Pecten*); 8. Black bindweed (*Polygonum Convolvulus*); 9. Snake-weed (*Polygonum lapathifolium*); 10. Charlock seeds, (*Sinapis, Raphanus, and Brassica*) in barley sometimes.

6208. *Weeds which are principally objectionable as they encumber the soil* are, 1. Charlock, a name which is applied to four species of Cruciferae (viz. *Sinapis arvensis* and *nigra, Raphanus Raphanistrum*, and *Brassica Napus*); 2. Corn poppy (*Papaver*

Rhoeas); 3. Blue-bottle (*Centaurea Cyanus*); 4. Mayweed (*Anthemis Còtula*); and 5. Corn marigold (*Chrysanthemum segetum*).

6209. *The weeds called underlings*, or such as never rise in the crops, are, 1. Groundsel (*Senecio vulgaris*); 2. Annual meadow grass (*Poa annua*); 3. Chickweed (*Stellaria media*); 4. Shepherd's purse (*Thlapsi bursa pastoris* and *erecta*); 5. Spurry (*Spergula arvensis*); 6. Chamomile (*Matricaria Chamomilla*); 7. Fat-hen (*Chenopodium album*); 8. Common corn salad (*Fedia olitoria*); 9. Flix-weed (*Sisymbrium Sophia*); 10. Common fumitory (*Fumaria officinalis*); 11. Sand mustard (*Sinapis muralis*).

6210. *Pasture weeds* are, 1. Dwarf-thistle (*Carduus aculís*); 2. Common chamomile (*Anthemis nobilis*); 3. Star-thistle (*Centaurea Calcitrapa*); 4. Ox-eye daisy (*Chrysanthemum leucanthemum*); 5. Great fleabane (*Conyza squarrosa*); 6. Cheese-rennet (*Galium verum*); 7. Long-rooted hawkweed (*Apargia autumnalis*); 8. Wild thyme (*Thymus Serpyllum*); 9. Sheep's sorrel (*Rumex Acetosella*); 10. Knot-grass (*Polygonum aviculare*); 11. Yellow rattle (*Rhinanthus Crista galli*); 12. Common carline thistle (*Carlina vulgaris*).

6211. *Pasture weeds which generally prevail in loamy soils*, and such also as are prevalent in clayey and damp soils, are principally as follows:—1. Yellow goat's-beard (*Tragopogon pratensis*); 2. Marsh thistle (*Carduus palustris*); 3. Melancholy thistle (*Carduus heterophyllus*); 4. Meadow thistle (*Carduus pratensis*); 5. Common butter-bur (*Tussilago Petasites*);

6. Common ragwort (*Senecio Jacobæa*); 7. Common daisy (*Bellis perennis*); 8. Common black knapweed (*Centaurea nigra*); 9. Broad-leaved dock (*Rumex obtusifolius*); 10. Orchis (*O'rchis mascula, maculata, latifolia, mörto, and pyramidalis*); 11. Common cow-parsnep (*Heraclium Sphondylium*); 12. Sedge (*Carex*), various species.

6212. *A catalogue of weeds* could be of little use to the agriculturist, as the mere names could never instruct him as to their qualities as weeds, even if he knew them by

their proper names. Besides, weeds which abound most, and are most injurious in one district, are often rare in another. Thus, the poppy abounds in gravelly districts, the charlocks on clays, the chickweed, groundsel, nettle, &c., only on rich soils. A local Flora, or any of the national Floras, as Lightfoot's *Flora Scôtica*, and Smith's *British Flora*, and, we may be allowed to add, our own *Encyclopædia of Plants* and *Hortus Britânnicus*, by pointing out the habits of indigenous plants, may be of considerable use to the agriculturist who has acquired a slight degree of the science of botany.

BOOK VII.

THE ECONOMY OF LIVE STOCK AND THE DAIRY.

6213. *THE grand characteristic of modern British farming*, and that which constitutes its greatest excellence, is the union of the cultivation of live stock with that of vegetables. Formerly in this country, and in most other countries, the growing of corn and the rearing of cattle and sheep constituted two distinct branches of farming; and it was a question among writers, as, according to Von Thaer, it still is in Germany, which was the most desirable branch to follow. The culture of roots and herbage crops at last led gradually to the soiling or stall-feeding husbandry, in imitation of the Flemings; and afterwards, about the middle of the last century, to the alternate husbandry, which is entirely of British invention, and has been more effectually than any thing else the means of improving the agriculture of the districts where it is practised.

6214. *It is observed* by Brown, that "though horses, neat cattle, sheep, and swine are of equal importance to the British farmer with corn crops, yet we have few treatises concerning the animals, compared with the immense number that have been written on the management of arable land, or the crops produced upon it. But though so little has been written, the improvement of those animals has not been neglected; on the contrary, it has been studied like a science, and carried into execution with the most sedulous attention and dexterity. We wish it could be stated, that one half of the care had been applied to the selecting and breeding of wheat and other grains, which has been displayed in selecting and breeding the best proportioned and most kindly feeding sheep. A comparison cannot, however, be made with the slightest degree of success; the exertions of the sheep-farmers having, in every point of view, far exceeded what has been done by the renters of arable land. Even with cattle considerable improvement has taken place. With horses, those of the racing and hunting kinds excepted, there has not been correspondent improvement; and as to swine, an animal of great benefit to the farmer, in consuming offal which would otherwise be of no value, it is to be regretted that very much remains to be done."

6215. *The first important effort in the improvement of live stock* was made by Robert Bakewell, who was born on his father's estate of Dishley, in 1726. Mr. Bakewell wrote nothing himself; so the first scientific work on the subject was written by George Culley, in 1782, who had formed himself on Bakewell's model. The systematic improvements of Mr. Bakewell were developed in various agricultural reports, and consisted in attempts to lessen such parts of the animal frame of cattle and sheep as were least useful to man, as bone, cellular substance, and appendages; at the same time increasing such other parts, as flesh or muscle, and fat, as become more important in the furnishing man with food. These ends he endeavoured to accomplish by a judicious selection of individuals, possessing the wished-for form and qualities in the greatest degree; which being perpetuated in their progeny in various proportions, and the selection being continued from the most approved specimens among these, enabled him at length to establish breeds with the desired properties. Later improvements have been grafted on these, and we find excellent observations on the subject from the pens of Cline, Dr. Coventry, Sir J. Sebright, Hunt of Leicester, and the Rev. H. Berry; and we have witnessed the strenuous and successful efforts of a Russell, a Coke, an Ellman, and others. The improvement in the sciences of comparative anatomy and physiology has also led to an amended practice both in breeding and in pathology. The example of various opulent proprietors and farmers in all parts of the empire tended to spread this improvement, by which the pursuit became fashionable. Add to these the accounts of the management of live stock in almost every county of the British Isles, as contained in Marshal's *Works* and the *County Reports*. From these sources we shall draw the information we are about to submit, and shall adopt the arrangement of the horse, the ass, the mule and hinny, the bull family and the dairy, the sheep, the swine, minor stock, and injurious animals or vermin.

CHAP. I.

The cultivated Horse. — *E`quus Cabállus* L.; *Mammàlia Bélluæ* L., and *Pachydérmes Solípedes* Cuvier. *Cheval*, Fr.; *Pferde*, Ger.; *Cavallo*, Ital.; and *Caballo*, Span.

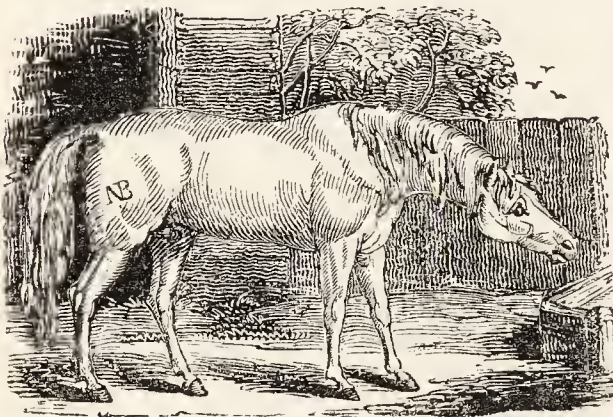
6216. *The horse family*, by far the most important among the brute creation as a servant to man, includes several species both in a wild and cultivated state, as the *E`quus Hemionus*, or wild mule, a native of Arabia and China, and which it is supposed would form an excellent race of small horses, could they be reduced to a state of domestication; the *E. Asinus*, or ass, well known; the *E. Zèbra*, or striped ass; the *E. Quágga*, by some considered a variety of the zebra; and the *E. bisúlcus*, or cloven-footed horse, a native of Chile, and by many supposed to belong to a distinct genus.

6217. *The common horse, justly considered as the noblest of quadrupeds*, is found in a wild state in the deserts of Great Tartary, in the southern parts of Siberia, and in other parts of Asia, and in the interior of Africa. He has long been domesticated and cultivated in most parts of the earth, for the various purposes of war, hunting, parade, the saddle, and draught; and in some places, partly for his flesh and the milk of the female. The parts of a horse, when no longer endued with life, are applied to various useful purposes. The blood is used as manure. The bones are broken and boiled, to produce oil, and are afterwards ground into an excellent manure; some of the bones are also employed in the mechanical arts. The flesh supplies food for the domestic carnivorous animals, the cat and dog; for carnivorous birds, kept for amusement or curiosity; for fish, &c. We shall consider the horse in regard to its varieties, organology, anatomy, physiology, diseases, breeding, rearing, training, feeding, and working

SECT. I. *Varieties of the Horse.*

6218. *The varieties of the domestic horse* are numerous. The indigenous horse of every country, operated on by climate, assumes that form best adapted to its locality. Man would soon, however, be led to mix with the native breeds that variety which presented in its aboriginal state the finest form and most valuable qualifications. This being found centred in the horses of Arabia, Persia, and Barbary, the inhabitants of Europe generally sought an amelioration of their own breeds by an admixture of oriental blood.

6219. *The Arabian horses* (fig. 818. is a portrait of one brought by Buonaparte from Egypt, and now living in the royal garden of Paris,) are reckoned the best, and the solicitude with which the Arabs preserve these horses pure and unmixed is remarkable. The care with which they are nurtured, and the skill displayed in their equestrian management, are no less admirable. None but stallions of the finest form and purest blood are allowed access to their mares, which is never permitted but in the presence of a professional witness or public officer, who attests the fact, records the name, and signs the pedigree of each. The *Persian horses* are considered next in value; and after them the horses of Andalusia in Spain. The *Barbary horses* are descended from the Arabians, and much esteemed. Jackson (*Empire of Morocco*, p. 42.) mentions one very fleet variety, used for hunting the ostrich, and fed entirely on camel's milk. The *horses of India*, though active and not ill formed, are small and vicious, the climate being unfavourable to their greater development. *Those of Tartary* are of a



moderate size; but strong, muscular, full of spirit, and active. The Tartars are considered skilful riders. Like the Kalmucks, they eat the flesh of horses as we do that of oxen, and use their milk either in curd or fermented.

6220. *Of the European varieties of the horse*, those of Italy were formerly in greater esteem than at present; but still those of the Neapolitans shine both under the saddle and in traces. Great numbers are bred in Sicily; those of Sardinia and Corsica are small, but active and spirited. The Swiss horses partake of the same qualities.

6221. *The Spanish horses* have long been highly esteemed. The invasion of the Moors, in 710, brought a vast influx of oriental blood into Spain; and the continuance of the Moorish yoke during several centuries produced altogether so improved a race there, that the best Spanish horses are preferred by some to the Barbs. The Spanish Genette has long been celebrated for its elegance, sprightliness, and durability. The best breeds of Spain are generally finely carcased, and well limbed, active, ready, and easy in their paces, docile and affectionate to their owners, full of spirit and courage, but tempered with mildness and good-nature; they are, for the most part, of a moderate size. Those which are bred in Upper Andalusia are deemed the most valuable. The Portuguese horses, or rather mares, were famous of old for being very fleet and long-winded; but of late, it is said, they are much degenerated.

6222. *France* abounds in horses of all kinds, whose origin may be traced to a mixture of their native breeds with the Asiatic introduced by the irruption of the Goths, and originally received from the Scythians, and the true eastern blood received from Spain, Barbary, and Arabia. With these admixtures, however, the horses of France have not yet borne a high character throughout Europe; and although under the dominion of Napoleon more than two hundred pure Arabian stallions were imported, and the northern states plundered of their choicest specimens, by which the breeds have been much improved; still France imports yearly vast numbers from this country, particularly hunters and high bred carriage horses. Of their own breeds, Limousin furnishes some good saddle horses, and hunters also. Next to those, Normandy claims precedence for a well-formed and useful breed. There are also very good *bidets*, or ponies, in Auvergne, Poitou, and Burgundy. Lower Normandy and the district of Cotentin furnish some very tolerable coach horses, and which are more active and appear more elastic in their motions than the Dutch horses. They have, however, a noble race of large draught horses equal to any seen in England, and among which the chesnut colour seems to prevail. The French horses generally are apt to have their shoulders although oblique, yet too loose and open, as those of the Barbs are usually too confined and narrow.

6223. *The Flemish horses* are inferior in value to the Dutch, having usually large heavy heads and necks; their feet also are immoderately large and flat, and their legs subject to watery humours and swellings.

6224. *Holland* furnishes a race of horses which are principally serviceable in light draught work: the best come from Friesland.

6225. *Germany* is not destitute of good horses. The native breeds, heavy and ill-formed, received their first improvement from admixture with the Asiatic horses. In after-times the Germans obtained still

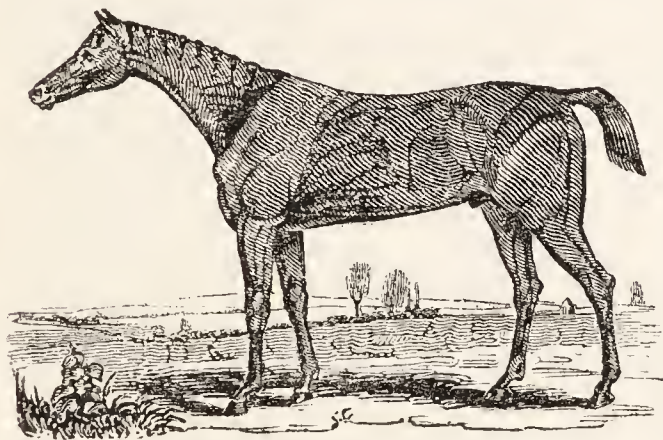
finer breeds from the Arabs, Turks, and the Barbary states, which they still preserve with some care as stallions: some good specimens are also obtained from Spain. In a general point of view, however, the German horses are more fitted for the manege than for racing or hunting; in which qualities they are inferior to the Hungarian and Transylvanian horses. The horses of Bohemia are not distinguished by any eminent qualities. The Hussars and Transylvanians are accustomed to slit the nostrils of their horses, under a notion of giving their breath a free passage, and improving their wind, as well as to render them incapable of neighing, which, in the field, would be often inconvenient. The Croatian horses are nearly allied in qualities and character to the Hungarian and Bohemian: these, as well as the Poles, are remarkable for being, as the French term it, *bégué*, or keeping the mark in their teeth as long as they live.

6226. *The Polish horses* are hardy, strong, and useful, but they are generally of a middling size. In the marshy parts of Prussia, and towards the mouth of the Vistula, there is a breed of tall strong horses, resembling those of Friesland, but of inferior value.

6227. *The horses of Russia* are not much regarded by other nations. They are small but hardy, and capable of enduring great fatigue. Great attention is, however, paid to such as are very fast in their trot; and such a breed is much encouraged for trotting matches on the snow and ice. Those of the Turkish breed are handsome and finely shaped, but too slight and weak for heavy cavalry. The Kalmuck horses are somewhat higher than the Russian common horses, and are so lasting and constitutionally strong as to be able to run three or four hundred English miles in three days. They subsist, summer and winter, solely upon grass in the great deserts which are between the rivers Don, Volga, and Yaik, where they are collected in great herds of four hundred, five hundred, or even a thousand. They are excellent swimmers, and pass the river Volga, where it is from one mile to two miles broad, with great ease.

6228. *The horses of Sweden* are low and small, and the Norway breed may be comprehended under the same description, but they are strong, hardy, and active. Denmark, and also Holstein and Oldenburg, boast a large variety of horses, which has long been esteemed as peculiarly adapted for heavy cavalry and carriage uses, though they are apt to fail with respect to elegance of limb and symmetry of parts; their heads being large, their shoulders heavy, their backs long, with croups too narrow to correspond with their fore parts. In the Islands of Feröe there is a race of horses of small growth, but strong, speedy, and very sure-footed. They are never shod, and feed abroad without shelter both summer and winter. In Suderoe, one of these islands, they have a peculiarly swift breed, of great use to the inhabitants, who catch their sheep, which are wild, by hunting them with a dog, pursuing them at the same time with their horses. The horses of Lapland are small of stature, but active and willing; they are used only in the winter season, in drawing sledges over the snow, and transporting wood, forage, and other necessaries; but in summer they are turned into the forests, where they form separate troops, strictly confined to their own quarters.

6229. *The British varieties of saddle horse* may be reduced to the racer, the hunter, the improved hack, the old English road horse, the galloway, and the pony; the two latter of which we shall consider in another place.



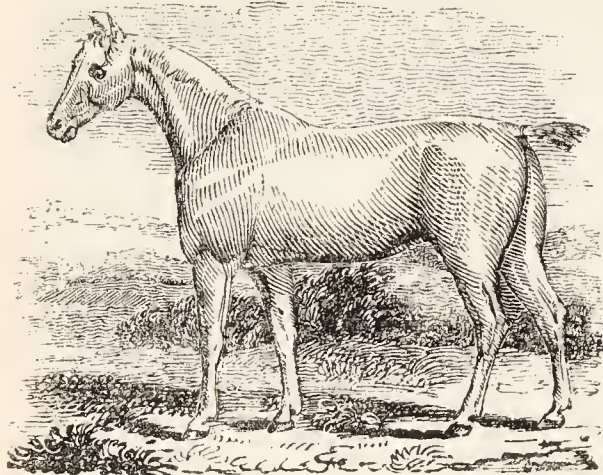
6230. *The race horse* (fig. 819.) is descended nearly in a direct line from the Arabian, the Persian, and the Barb. In an agricultural point of view, this celebrated breed might at first sight appear of little importance; but it is probable, that to the amusement afforded by it to the rich and powerful, we are indebted for the principal improvements in every other variety of this most valuable animal. Races or courses were very early a part of British sports; and it is natural to suppose that, on this account, endeavours would be made to improve and enlarge the breeds of the native horses. Roger de Bellesme, Earl of Shrewsbury, is the first on record who imported a Spanish stallion, the progeny of which was afterwards extolled by Michael Drayton, in his *Poly-olbion*; and, it is probable, the first amelioration of the native breeds was derived altogether from horses brought from Spain and the southern parts of

Gaul. In the reign of Henry IV., public ordinances were made favourable to the improvement of the breeding of horses, which would tend still further to extend the search after better specimens. There is reason, however, to believe, that the courses of those times were little more than ordinary trials of speed between the *indigenæ*, or these slightly improved breeds; and it was not until the days of Henry VII. and VIII., that the true eastern blood was collected in any considerable quantities. During these reigns, however, it becoming very general to import stallions from Arabia, Barbary, and Persia, a new and highly improved race rapidly extended itself. This improvement was carried subsequently to its acmé by an equally careful selection of mares as of horses; and thus we find king James importing a set of mares of the purest blood, significantly called the royal mares. From these periods, the breeding of the race horse was pursued with the utmost care, as well in regard to purity of blood, as in the increase of his bodily powers, by the most nutritious food and duly apportioned exercise, during his training for the courses, then becoming so fashionable in England. Thus has been produced a breed unrivalled throughout the world for symmetry of form, swiftness of progression, and durability under exertion. The accounts on record of feats performed by some of our horses on the turf are truly astonishing. Bay Malton ran at York four miles in seven minutes and forty-three seconds. Childers, known by the name of the flying Childers, moved through a space equal to eighty-two feet and a half in a second. After these Eclipse, Highflyer, Matchem, Hambletonian, and others, have contributed to keep up the reputation of the English racer.

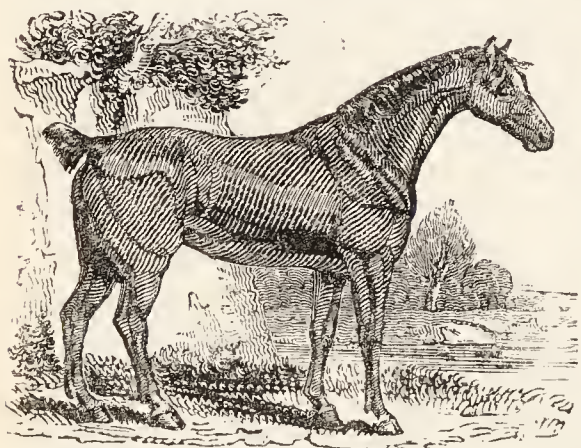
6231. *Climate has a great influence over the form of animals*, and that form is found indigenious to each which best fits it for the purposes required of it. In the arid plains of the east, where herbage is scarce, a form is given which enables its brute inhabitants to readily transport themselves from one spot to another; and as in every situation the flesh of the horse is greedily sought after by the predatory tribes, so here, where those are peculiarly strong and active, the horse is formed peculiarly agile and swift to escape their attack, as well as peculiarly light, that his weight might not sink him in the sandy plains, nor his bulk retard him in his flight. Removed, however, to more temperate climes, where vegetation affords by its luxuriance more nutriment, and where the restrictions of danger have ceased to operate, we no longer see him equally small and slender; but, with equal capacity for swift progression, we find him expanded into a form capable of keeping up that progression with a durability unknown to the original breeds from which he sprang. Symmetrically formed as we now see him, he at once evinces his claim to great speed. His bony skeleton exhibits a base founded on the justest geometrical principles, presenting a series of lengthened levers acting by means of a condensed muscular and tendinous organization of great power, on angles capable of great flexion and extension; while his pointed form fits him to cleave that atmosphere, from which his deep chest enables him to draw by extensive inspirations wind and vigour to continue his exertions. Purity of blood, by which is meant the result of confining to particular races or

breeds the means of continuing their species, is observed

820

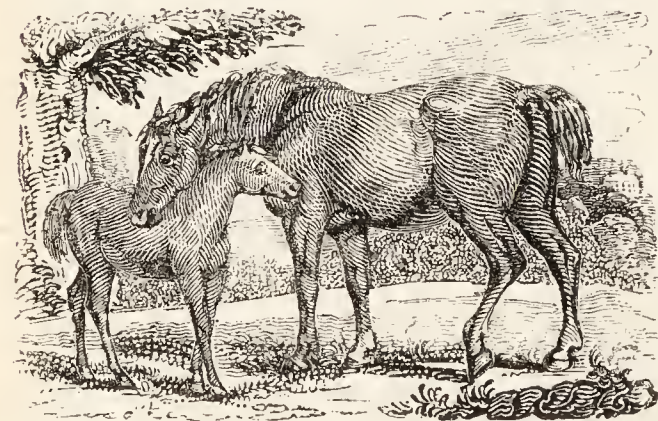


6233. *The improved hackney* (fig. 821.) is derived, like the former, from a judicious mixture of the blood breed with the native horse, but exhibiting a greater proportion of the latter. Hackneys are now, however, mostly bred from stallions possessing nearly the same proportion of blood with the hunter; but with a form and qualities somewhat different. In the hackney, as safety is as requisite as speed, we look particularly to the fore parts to see that they are high and well placed; that the head is not heavy, nor the neck disproportionately long or short; that the legs stand straight (that is, that a perpendicular line drawn from the point of the shoulder should meet the toe); and that the elbows turn out: and although a perfect conformation in the hinder parts is necessary to the hackney, it is in some measure subordinate to the same perfection in the fore parts; whereas in the racer and hunter, but particularly in the former, the form of the hinder is even of more consequence than that of the fore parts.



might almost be reckoned among its *indigenæ*: although it is probable that it originally sprang from a judicious culture from horses of Norman, German, or Flemish extraction, which horses were very early im-

822



ported to enlarge our small breeds, and to render them equal to the heavy loads they were accustomed to carry as pack-horses; and of which kind the old English road horse unquestionably is. (fig. 822.) Neither is it at all impossible, that, in the more fertile parts of the island, an original breed existed of considerable power and bulk. Athelstan expressly prohibited the exportation of English horses, and the "scythed chariots drawn by fiery steeds" of the ancient Britons struck terror even into Caesar's legions. These accounts of the antiquity of the English horse, receive additional strength from the notices we obtain of the fossil bones of horses having been found, according to Parkinson, in various parts of the island. The old English road horse possessed great power, with short joints, a moderate shoulder, elevated crest, with legs and feet almost invariably good. The heights varied from fifteen hands to fifteen hands two inches; and the colours were frequently mixed.

6235. *The objection, however, to English horses*, both of the original and of the more early improved breeds, and which is even still seen among them, is, that they want grace or expression in their figure and carriage; that they are somewhat obstinate and sullen; and that a certain stiffness in their shoulders, and want of suppleness and elasticity in their limbs, render them unfit for the manege. As this is an important charge against the excellence of our breeds, it may be worth consideration how far it is founded in truth. Commerce requires despatch, and England as a great commercial country makes every thing subservient to an economical use of time. Conformably to these principles, many of the qualities of our horses, but principally those of flexibility and safety in progression, are certainly sacrificed to speed, in which they undoubtedly excel all horses in the world. It is well known that all animals intended by nature for quick progression, are formed low in their fore parts, and have usually narrow upright shoulders; which defects are too common in English horses in general. On the contrary, in most of the improved breeds of continental horses, the fore hands are elevated, and the shoulders wide and oblique; by which, flexibility and safety in progression are gained at some expense of celerity; for the strong lumbar muscles of horses so formed, operating on the lengthened spinous processes of the dorsal vertebrae with increased advantage, elevate the fore parts higher; and even in default of this form in the fore parts, yet a corresponding effect is produced in foreign horses by the great strength and expansion of their haunches and croups, and by the greater inclination in their hinder extremities towards the common centre of gravity of the body: for as speed depends first on the extent to which the angles of the limbs can be opened, and secondly, on the efforts of the body in its transit to counteract the tendency to the common centre of gravity, the earth; so it is evident that the form which is the most favourable to speed, is less so to safety or flexibility in progression.

6236. *The Irish road horse, or hunter*, coeval with, or probably in some measure subsequent to, the culture of the old English road horse, was a still more excellent breed. With similar properties, but an improved form, with a great acquired aptitude for leaping, it gained the name of the Irish hunter; and when the dogs of the chace were less speedy than they now are, this horse was equal to every thing required of him as a hunter; even now the possessors of the few which remain find, particularly in an enclosed and deep country, that what others gain by speed these accomplish by strength to

observed with equal care and jealousy by the breeders of the English race, as by the Arabians; and turf jockeys assert they can discover a taint or departure from this purity to the sixteenth remove.

6232. *The hunter* (fig. 820.) is derived from horses of entire blood, or such as are but little removed from it, uniting with mares of substance, correct form, and good action. In some instances hunters are derived from large mares of the pure breed, propagating with powerful stallions of the old English road horse. This favourite and valuable breed is a happy combination of the speed of the Arabian, with the durability of the native horse. More extended in form, but framed on the same principles, he is able to carry a considerable weight through heavy grounds, with a swiftness equalled only by the animal he pursues, and with a perseverance astonishing to the natives of every other country. Hence the extreme demand for this breed of horses in every European country; our racing stallions being now sent to propagate in the eastern climes, whence they were some of them originally brought.

6234. *The old English road horse*. This most useful breed is now nearly extinct, although some northern agriculturists appear to be making efforts to revive the race. It has so long been known in this country that it

might almost be reckoned among its *indigenæ*: although it is probable that it originally sprang from a judicious culture from horses of Norman, German, or Flemish extraction, which horses were very early im-

go through any ground, and activity sufficient to accomplish the most extraordinary leaps. As roadsters, these horses have ever proved valuable, uniting durability, ease, and safety with extreme docility. In form they may be considered as affording a happy mixture of an improved hack with our old English roadster.

6237. *The British varieties of saddle horse of more inferior description* are very numerous, as cobs, galloways, and ponies. Cobs are a thick, compact, hackney breed, from fourteen hands to fourteen hands two inches high, in great request for elderly and heavy persons to ride, or to drive in low phaetons, &c. Galloways and ponies are lately in much request also for low chaises; a demand which will lead to a cultivation of their form; the number bred requires little increase, as several waste districts or moors throughout England are already appropriated principally to the purpose of rearing ponies.

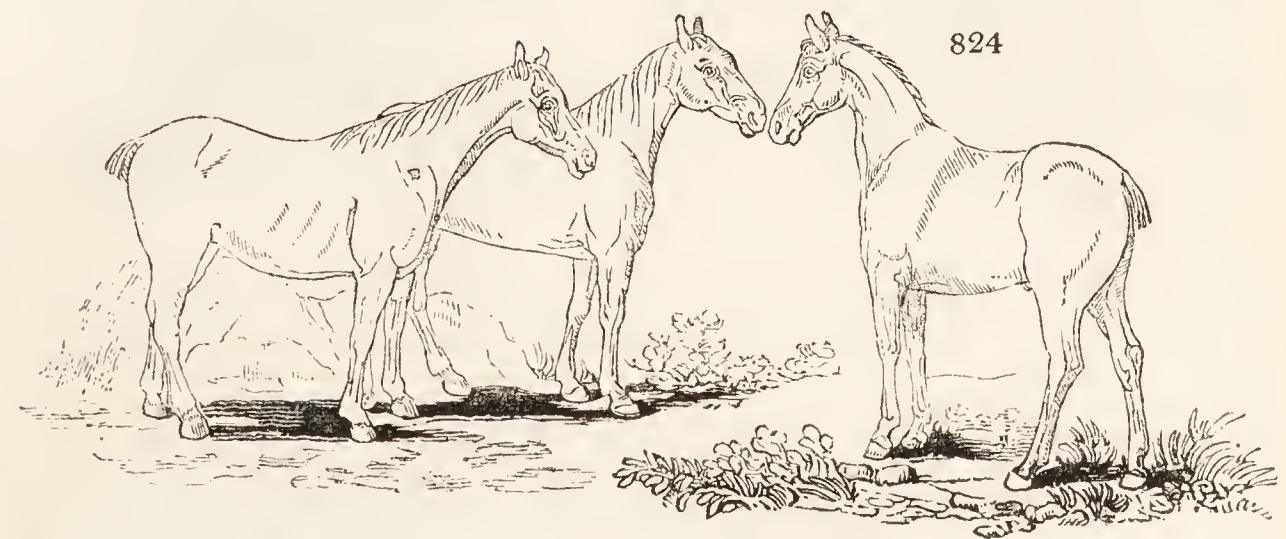
6238. *The British varieties of war or cavalry horse, and of carriage and cart horse*, are considered to have been derived from the German and Flemish breeds, meliorated by judicious culture. Most of the superior varieties contain a mixture of Arabian or Spanish blood. Cavalry horses are found amongst the larger sort of hackneys; and the observations made in the late wars sufficiently show the justice of the selection. Except in a few unhappy instances, where a mistaken admiration of the Hulus had led to selecting them too light, the English cavalry horse possessed a decided superiority over the best French horses in strength and activity, as well as over the Germans, whose horses on the other hand, by their bulk and heavy make, were incapable of seconding the efforts of the British dragoons. The coach, chariot, and stage horses are derived many of them from the Cleveland bays, further improved by a mixture of blood. Others are bred from a judicious union of blood and bone, made by the breeders in Yorkshire, Lincolnshire, and other midland counties.

6239. *The varieties of draught horse* were originally as numerous as the districts in which they were bred, each having its favourite breed; but since the intercourse among farmers and breeders has been greater, those in common use are so mixed as to render it difficult to determine of what variety they partake the most. At present the principally esteemed draught horses are the Suffolk punch, the Cleveland bay, the black, and the Lanark or Clydesdale. The native breeds of draught horses of England, Scotland, Wales, and Ireland, are much too small for the purposes of agricultural draught as now conducted; but by cultivation, the improved breeds pointed out have furnished such animals as are equal to every thing required of them.

6240. *The black horse* (fig. 823.), bred in the midland counties of England, is a noble and useful animal; and furnishes those grand teams we see in the coal, flour, and other heavy carts and waggons about London; where the immense weight of the animal's body assists his accompanying strength to move the heaviest loads. But the present system of farming requires horses of less bulk and more activity for the usual agricultural purposes, better adapted for travelling, and more capable of enduring fatigue; consequently this breed is seldom seen in the improved farms. The black cart horse is understood to have been formed, or at least to have been brought to its present state, by means of stallions and mares imported from the Low Countries; though there appears to be some difference in the accounts that have been preserved, in regard to the places whence they were originally brought, and to the persons who introduced them. (*Culley on Live Stock*, p. 32., and *Marshal's Economy of the Midland Counties*, vol. i. p. 306.) Marshal, under too confined a view, and probably prejudiced against the breed on account of its fancied want of spirit, as well as for the alleged tendency to become flat and

pommiced in the feet, is most unreasonably severe on it, when he says, "the breed of grey rats, with which this island has of late years been overrun, are not a greater pest in it than the breed of black fen horses; at least while cattle remain scarce as they are at present, and while the flesh of horses remains to be rejected as an article of human food." (*Marshal's Yorkshire*, vol. ii. p. 164.) The present improved sub-variety of this breed is said to have taken its rise in six Zealand mares, sent over from the Hague by the late Lord Chesterfield, during his embassy at that court.

6241. *The Cleveland bays* (fig. 824.), which owe some of their most valuable properties to crosses with

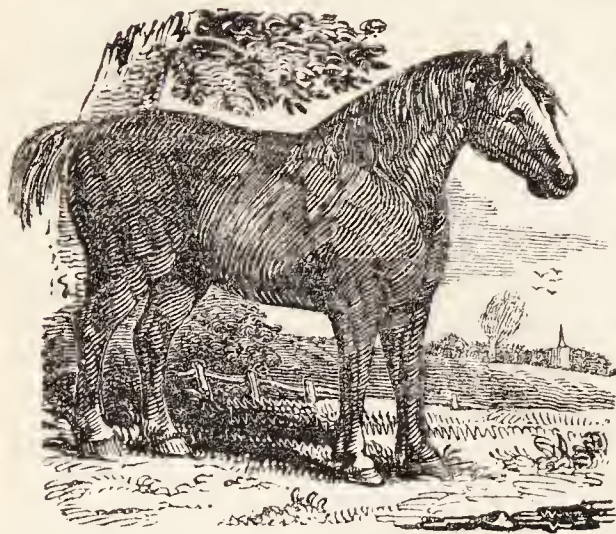


the race-horse, have been long celebrated as one of the best breeds in the island; but they are said to have degenerated of late. They are reared to a great extent in Yorkshire, the farmers of which county are remarkable for their knowledge in every thing that relates to this species of live stock. In activity and hardiness, these horses, perhaps, have no superior. Some capital hunters have been produced by putting full-bred stallions to mares of this sort; but the chief object latterly has been to breed coach-horses, and such as have sufficient strength for a two-horse plough. Three of these horses draw a ton and a half of coals, travelling sixty miles in twenty-four hours, without any other rest but two or three baits upon the road; and frequently perform this labour four times a week.

6242. *The Suffolk punch* (fig. 825.) is a very useful animal for rural labour, and is particularly esteemed by the farmers of Norfolk, Suffolk, and Essex, but the merit of this breed seems to consist more in constitutional hardiness than in any apparent superiority of shape. "Their colour is mostly yellowish or sorrel, with a white ratch or blaze on their faces; the head large, ears wide, muzzle coarse,

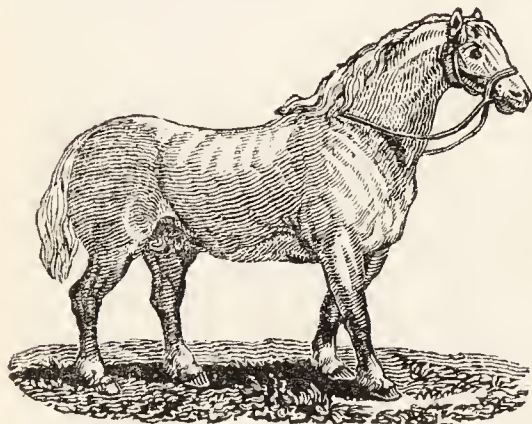
fore-end low, back long sometimes, but always very straight, sides flat, shoulders too far forward, hind-

825



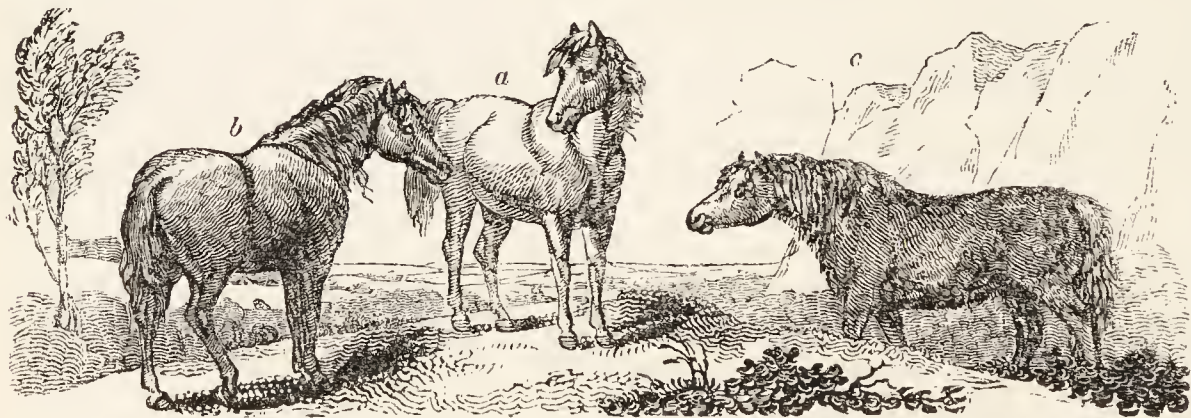
quarters middling, but rather high about the hips, legs round and short in the pasterns, deep-bellied, and full in the flank. Here, perhaps, lies much of the merit of these horses; for we know, from observation and experience, that all deep-bellied horses carry their food long, and consequently are enabled to stand longer and harder days' works. However, certain it is, that these horses do perform surprising days' works. It is well known, that the Suffolk and Norfolk farmers plough more land in a day than any other people in the island; and these are the kind of horses every where used in those districts." (*Culley on Live Stock*, p. 27.) Since Culley's time much pains have been taken to improve this useful breed, and to render them, by cultivation, fitted not only for heavy but for light work. It is no uncommon thing for a Suffolk stallion to fetch from 200*l.* to 300*l.* The best show of these stallions in England is at Woodbridge Lady-day fair, where Suffolk cart mares have brought from 100*l.* to 150*l.*, and one mare and her offspring a few years ago at this fair brought 1000*l.* The figure (825.) hardly does justice to the animal. (M.)

6245. *The Clydesdale horse* (fig. 826.) has been long in high repute in Scotland and the north of England; and, for the purposes of the farmer, is probably equal to any other breed in Britain. Of the origin of this race, various accounts have been given, but none of them so clear, or so well authenticated, as to merit any notice. They have got this name, not because they are bred only in Clydesdale or Lanarkshire, for the same description of horses are reared in the other western counties of Scotland, and over all that tract which lies between the Clyde and the Forth, but because the principal markets at which they are sold, Lanark, Carnwath, Rutherglen, and Glasgow, are situated in that district, where they are also preserved in a state of greater purity than in most other parts. They are rather larger than the Suffolk punches, and the neck is somewhat longer; their colour is black, brown, or grey, and a white spot on the face is esteemed a mark of beauty. The breast is broad; the shoulder thick, with the reaching cartilaginous portion of the blade-bone nearly as high as the withers, and not so much thrown backwards as in road horses; the hoof round,



and usually black, with wide heels; the back straight and broad, but not too long; the hucks visible, but not prominent, and the space between them and the ribs short; the tail heavy, and well haired; the thighs meeting each other so near as to leave only a small groove for the tail to rest on. One most valuable property of this breed is, that they are remarkably true pullers, a restive horse being rarely found among them.

6244. *The Welsh horse* (fig. 827. a) bears a near resemblance, in point of size and hardiness, to the best of



the native breed of the highlands of Scotland, and other hilly countries in the north of Europe. It is too small for the present two-horse ploughs; but few horses are equal to them for enduring fatigue on the road. "I well remember," says Culley, "one that I rode for many years, which, to the last, would have gone upon a pavement by choice, in preference to a softer road." (*Observations on Live Stock*, p. 35.)

6245. *The galloway* (b), properly so called as being found chiefly in that province of Scotland, has now become very rare, the breed having been neglected from its unfitness for agricultural purposes. Galloway is, however, used as a term for any horse between the pony size and the hack; and in this point of view is sufficiently numerous, and very commonly bred by small farmers on commons and wastes. The true galloway is somewhat larger than the Welsh horse, and is said to resemble the Spanish horses; there is also a tradition, that some of the latter, that had escaped from one of the vessels of the Armada, wrecked on the coast of Galloway, were allowed to intermix with the native race. Such of this breed as have been preserved in any degree of purity are of a light bay or brown colour, with black legs, and are easily distinguished by the smallness of their head and neck, and the cleanness of their bone.

6246. *The still smaller horses of the Highlands and isles of Scotland*, (c) are distinguished from larger breeds by the several appellations of ponies, shelties, and in Gaelic of garrons or gearrons. They are reared in great numbers in the Hebrides, or western isles, where they are found in the greatest purity. Different varieties of the same race are spread over all the Highland districts, and the northern isles. This ancient breed is supposed to have been introduced into Scotland from Scandinavia, when the Norwegians and Danes first obtained a footing in these parts. "It is precisely the same breed that subsists at present in Norway, the Feroe Isles, and Iceland, and is totally distinct from every thing of horse kind on the continent of Europe, south of the Baltic. In confirmation of this, there is one peculiar variety of the horse in the Highlands, that deserves to be noticed: it is there called the eel-backed horse. He is of different colours, light bay, dun, and sometimes cream-coloured; but has always a blackish list that runs along the ridge of the back, from the shoulder to the rump, which has a

resemblance to an eel stretched out. This very singular character subsists also in many of the horses of Norway, and is nowhere else known." (*Walker's Hebrides*, vol. ii. p. 158.) "The Highland horse is sometimes only nine, and seldom twelve hands high, except in some of the southern of the Hebrides, where the size has been raised to thirteen or fourteen hands by selection and better feeding. The best of this breed are handsomely shaped, have small legs, large manes, little neat heads, and are extremely active and hardy. The common colours are grey, bay, and black; the last is the favourite one." (*General Report of Scotland*, vol. iii. p. 176.)

SECT. II. *Organology or exterior Anatomy of the Horse.*

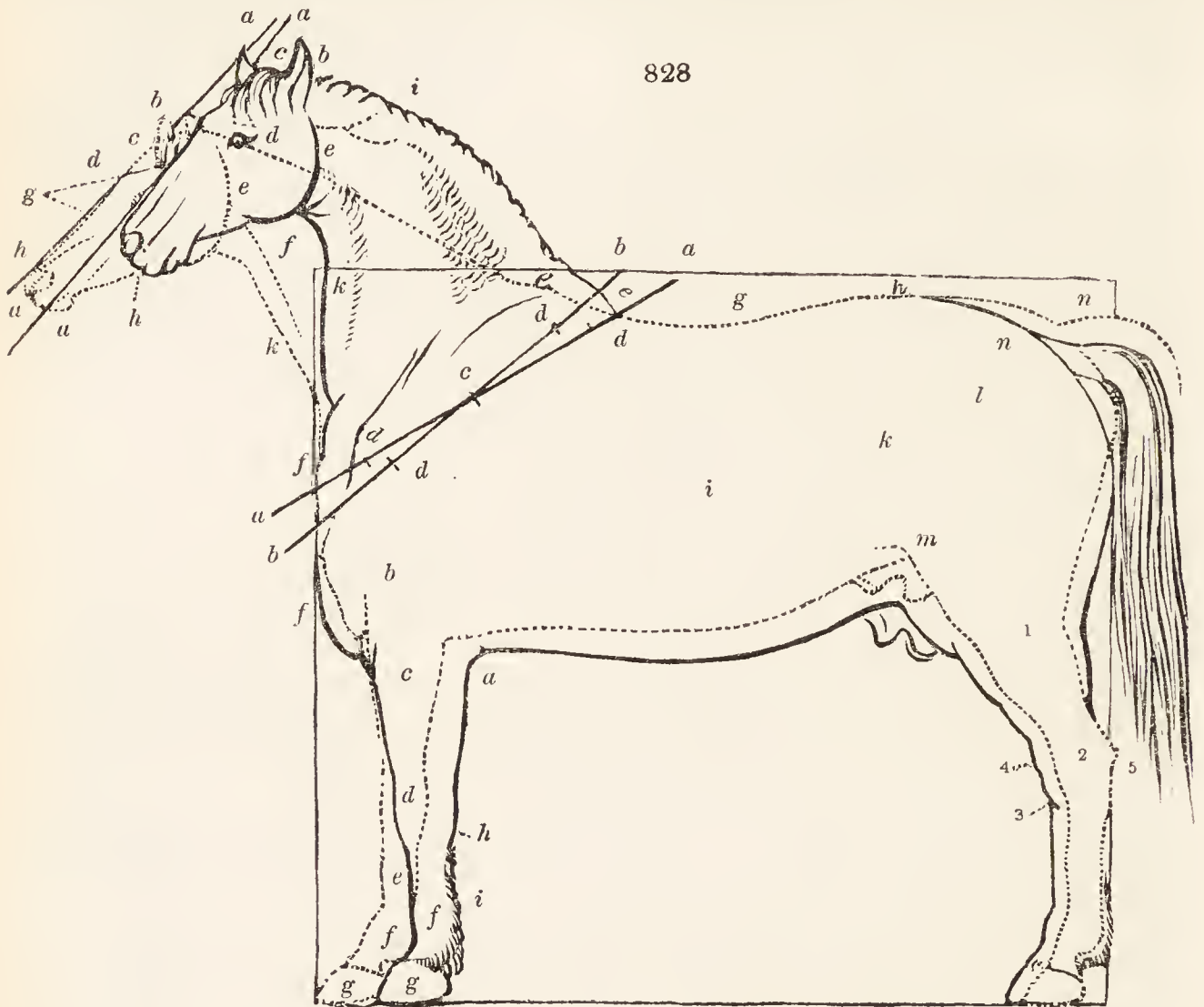
6247. *A just knowledge of the exterior conformation of the horse*, to be able to form a correct judgment on the relative qualities of the animal, forms the *ne plus ultra* of a scientific horseman's aim; but it is a branch of knowledge not to be obtained without much study and experience. In considering a horse exteriorly, his age, his condition, and other circumstances should be taken into the account; without which attention it is not possible to determine, with precision, the present or future state of a horse when he is seen under various peculiarities. A horse of five years old, though considered as full grown, yet experiences very considerable alterations of form after that period. He then becomes what is termed *furnished*; and all his points (*i. e.* his adult form), before hidden in the plumpness of youth, or disguised by extreme obesity, now show themselves. From the effects of muscular exertion promoting absorption, he becomes more angular, and to the painter's eye, would prove more picturesque, but less beautiful. A horse likewise low in flesh and condition, is hardly the same animal as one in full flesh and condition; and again, the sleekness acquired from relaxed labour, with full and gross feeding, is very unlike the robust form acquired from generous diet with correspondent exertion.

6248. *The examination of the subject of organology* is conveniently pursued by dividing it into head, neck, trunk, or body, and extremities or legs. The greater number of well proportioned horses, with the exception of the head and neck, come within a quadrangle; not one strictly equilateral as depicted by Lawrence (Richard) and Clark, but one whose horizontal dimensions are usually between a twenty-fourth and twenty-eighth greater than their perpendiculars. It must, however, be kept in mind, that with some considerable deviations from this quadrangular form, many horses have proved superiorly gifted in their powers; and that a deviation from these proportions appears in some instances, as in that of the race horse, not only favourable, but necessary also to his exertions. Nature will not be limited, and the perfection of her operations is not alone dependent on the arbitrary arrangement of parts, but on a harmony and accordance of the whole, internal as well as external. To the artist, however, such admeasurement is useful, inasmuch as it prevents any singular departure from a symmetrical appearance, which is but too common among our animal draughtsmen. To the amateur it also offers a convenient, though not an unerring guide. Our exemplification of the organology appears by placing a blood and a cart horse within the same square (*fig.* 828.), by which the differences between the various parts of the one and the other are readily contrasted.

6249. *The organs of the head.* The head of the horse is remarkable for its dimensions, formed by an elongation of the jaws; yet in him, as in most of the grazing tribes, its bulk is in an inverse proportion to the length of the neck, otherwise the muscles would not be able to lift it. It is an important part considered as relative to beauty alone, it being in the inferior heavy breeds but little marked by grace or expression; but in the improved varieties it presents lines worthy the painter's pencil and the poet's fancy. Neither is it too much to say, that in no part of the body is this amelioration of breed so soon detected as in the head. Can any thing be conceived more dissimilar than the small inexpressive features of the cart horse, and the bold striking ones that grace the head of the blood horse? The quick succession of movements in his pointed ears, the dilatations of his expanded nostrils, or his retroverted eyes, which give fire and animation to the character of his head when under the influence of any excitement. This is the more worthy of remark, when it is considered that some of the principal aids to expression in the human countenance are wanting in the horse. Man borrows much of his facial expression from his eyebrows, and when to these the varied action of the mouth is added, it amounts to more than a half of the total expression. A great accession of beauty is gained in the improved breeds by the increase of the facial angle, which in them is about 25° , but in the heavy breeds is usually only 23° (*aaa*).

6250. *The ears (bb)* in the improved breeds are small and pointed; in the heavy they are not only large and ill shaped, but they frequently separate from each other; these defects gave rise to the barbarous custom of cropping, now happily in a great measure abolished. The ears are criteria of the spirit, as well as of the temper; we have seldom seen a horse which carried one ear forward and the other backward during his work that was not hardy and lasting. Being not subject to early fatigue, he is attentive to every thing around him, and directs his ears different ways to collect sound from every quarter. The ears are also indications of temper, and a horse is seldom either playful or vicious but his ears are laid flat on the neck. It is fortunate that we are provided with such a warning, by an animal that does not want craft to surprise us, nor strength to render his resentment terrible.

6251. *The forehead* next presents itself (*c c*), straight, and of a proper width in the improved breeds, adorned by nature with an elegant portion of hair, which, detaching itself from the rest of the mane, flows down the face to protect both that and the ears from the attacks of insects.



6252. *The eyes* (*d d*) deserve particular attention, not only for their utility, but as objects of beauty and expression. In the blood horse the orbital fossæ, or eye-sockets, are more prominent and more inclined, by which the axes of his eyes diverge more from each other than those of the heavy breed; by which not only he is enabled to see further behind him, but the prominence of his eyes gives great beauty and expression to the blood head. The further consideration of the eyes, and their criteria of soundness, will be postponed to the anatomical detail. In old horses most of the fat of the body, which is more superficially placed in the young, becomes absorbed; in this way the eye, which is usually embedded in a vast quantity of this matter, losing its assistance, sinks within its orbits, and thus the cavities above, called eye-pits, shows themselves deeply in an aged horse.

6253. *From the ears to the angle of the jaws* (*e e*) large vessels and extensive glands are situated. Within these branches of the posterior jaw is lodged the throat, and it will be observed how necessary it is that these branches should expand sufficiently to admit of the motions of the head, particularly of those influenced by the reining-in of the bridle; otherwise the blood-vessels and other parts must be injuriously pressed upon.

6254. *The hollow between the jaws is called the channel*, and at the under part of it (*f*) a considerable branch of an artery proceeds from the inner side over and around the outer, which branch forms the most convenient situation for feeling the pulse of the horse.

6255. *The face* (*g*) of the improved breed of horses presents either a straight line, or one slightly curved inward towards the lower part; whereas, in the heavy breeds, it is very commonly found to be curved outward. This part comprises, as with man, from the forehead to the lips. When the face is covered with white, it is considered a blemish; but when a white spot only exists in the forehead, it is considered a beauty.

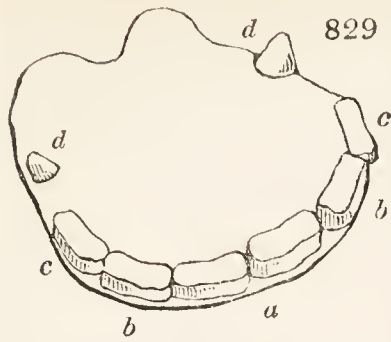
6256. *The markings in the face are useful to describe a horse by*, and frequently lead to the recovery of a strayed or stolen one. In regimental accounts these marks are carefully noted. When a spot extends down the face, it is termed a blaze; and when further continued into the muzzle, it is called blaze and snip. When a star is distinct, but with it there are white markings which begin some distance below it, and are continued downwards, it is called a race.

6257. *The muzzle* (*h h*) includes the lips, mouth, and nostrils; the darker the colour of this part the more is the horse esteemed: very dark brown horses are an exception, for in them it is usually of a tan colour, and is praised both as a beauty and indicative of excellence. It is both a beauty and an excellence that the nostrils be thin, angular, and large.

6258. *The lips* should be thin, firm, and by no means loose and pendulous, as is the case in the old and sluggish. The lips in the horse are the principal organs of touch and discrimination, and hence are exquisitely sensible.

6259. *The form of the mouth, as receiving the bit, is important.* It is also of more consequence than is usually supposed, that its commissure or opening be sufficiently deep; when shallow, it is not only inelegant, but it will not admit a bridle favourably into its proper resting place upon the bars. Within the mouth are situated the teeth, which are so placed as to have interrupted portions of jaw above and below of considerable extent. These vacancies are called *bars*, and are parts of extreme importance to the horseman, as it is by means of agents called bits resting on these parts, and operating on their sensibility by means of a lever, the long arm of which is in the hand of the rider, that he ensures obedience. In aid of this mechanism, to one portion of this lever is attached a chain, called a curb, which acting on the outer part of the chin, increases the pressure. This latter part has been called the *barb* or *beard*, but its situation is evidently above that.

6260. *The teeth* (fig. 829.), which present themselves on the lower parts of the jaws, are the incisive and canine. The two front incisives are popularly called nippers or gatherers (*a*); the two next adjoining, separators or middle teeth (*b*); and the outer, the corners (*c*); but it would be more definite to say the first, second, and third incisives, beginning at the corner. The tusks or tushes (*d d*) occupy part of the intermediate space between the incisive and grinding teeth. The teeth, as criteria of age, will be considered in another place, and as organs of mastication, they will be further noticed in the anatomical detail.



6261. *The organs of the neck.* The exterior parts which compose the neck are first the upper surface, which is furnished throughout its whole extent with an elegant assemblage of hair called mane (fig. 828. *e e*). In some instances, as in stallions, it is of enormous length and thickness. In dark-coloured horses it is commonly black, but in horses of colours approaching to a light hue the reverse is frequently seen, and the mane and tail are in these often lighter than the body.

6262. *To make the hairs of the mane and tail lie smooth* is an object with most horsemen, but the pulling the hair out in tufts by wrapping it round the fingers is a most erroneous practice, and not only at the time frustrates the end intended, but a mane so pulled will seldom hang well after. The writer of this has always made use of a three-pronged angular mane-puller, which, if used two or three times a week, will bring both mane and tail into perfect order, and will keep them so. This iron is manufactured and sold by Long, veterinary instrument maker in Holborn, London.

6263. *The upper surface of the neck* (*i*) should form a moderate but elegant curve, which is greatly favourable to beauty: this curve is, however, not so considerable in the pure eastern variety as in the better sort of northern horse.

6264. *The under surface of the neck* (*k k*) should be nearly straight; in the cock-throttled horse it arches outwards, and the upper surface in these instances is sometimes hollowed inwards in equal proportions, when such horse is called ewe-necked. When this deformity is considerable, it prevents the head from being carried in its true angle, and particularly so under the action of the bridle; in which case the nose being projected forwards, carries the axis of the eyes upwards: such horses are called stargazers; and it is to be observed that they are seldom safe-goers. In mares and geldings a very just criterion of a sluggish disposition, may be formed from the presence of a considerable quantity of flesh on the upper surface of the neck: when the crest is very thick and heavy, it is almost an unerring prognostic of a decided sluggard. In stallions it, however, forms a distinctive sexual mark, and therefore is less to be depended upon in them. In a well-proportioned horse, the length of the neck, the length of the head, and of the angle uniting the two, should give the height of the withers from the ground. When the neck is too long, the head must of course gravitate by the increased length of the arm of the balance; it likewise seldom presents a firm or proper resistance to the bridle. When, on the contrary, the neck is too short, the head is frequently ill placed, and the lever in the hand of the rider will be too short also.

6265. *The organs of the trunk or carcase* are various. Considered as a whole, Clark has not unaptly likened it, when separated from the limbs, to a boat; within which are disposed various important viscera. The bony ribs he likens to the wooden ones encompassing the vessel, and the sternum or breast-bone, being perpendicularly deep and thin, carries the resemblance further, and fits the machine to cleave the air as the boat does the water. Within this animal vessel, according with the justest mechanical principles, the weightiest of the viscera, the liver, is placed in the centre, and the others follow nearly in the relative order of their gravity; so that the lungs, the lightest of the whole, are stowed in front, where great weight would have been most disadvantageous.

6266. *The shoulders* (*a a, b b*) are commonly considered as extending from the withers above to the point in front, and to the line behind formed from the elbow upwards: but a correct description considers them as those parts immediately concerned in motion; that is, the scapula or blade-bone, and its attachments. The shoulders are too apt to be confounded with the withers above, and with the arm below, erroneously called the point of the shoulders. From this confusion, great error is committed in appreciating their nature and action; but this is removed by recourse to the skeleton (fig. 830. *i, k, l*). The withers (*e e*) may be justly proportioned at the same time that the shoulders may be narrow, straight, and altogether badly formed, and *vice versâ*. The shoulders should be muscular and narrow, but not heavy; and to determine between these essential points, requires the eye of experience in the viewer, and the presence of condition in the viewed. A muscular shoulder is essentially necessary, when we consider that the fore extremities are wholly connected by muscle, and not as in man, by the intervention of the bony union of the clavicle or collar bone. In the horse, therefore, we find that large muscular masses unite the shoulder blade, by its upper and inner surfaces, to the chest; while other powerful muscles suspend as it were the machine between them. By this contrivance, elasticity is preserved and strength gained; for had the shoulders possessed a bony connection, when the body is propelled forwards, its weight and force being received by the fore extremities, painful and hurtful shocks would have been experienced at every step. Powerful muscles for the shoulders are also as necessary for progression as for attachment. It is not therefore with judgment that a very thin meagre shoulder is commonly preferred. It is by the union of strength with just proportions, and a proper situation of the parts, that the value of the animal is determined.

6267. *The centre of action in the shoulders* (*c*) is in their common centre, and the extent of action of any part moving on its centre, is dependent on the length of such part; the motion the shoulder enjoys is confined to the perpendicular backwards, and to as great an elevation of the muscles as they will admit of forwards. It will be therefore evident that the more oblique is the situation of the shoulder blade, the greater number of degrees it can go through; it must be as evident also that when the shoulder blade is long and deep, as well as oblique, that this advantage is increased. It is commonly observed, although it is not invariably the case, that when the shoulder is short, it is also upright (*b b*). Obliquity and length in the shoulder favour the safety of the progression also: for as the angles formed between the shoulder, the arm, and fore-arm, are consentaneous, and make, when in action, a bony arch; so the obliquity and length of the shoulders is favourable to a due elevation of the limb, on which, in a great degree, depends the safety of progression. Thus mares are, *ceteris paribus*, more unsafe than horses, their shoulders being short to correspond with the low mare-like forehead; and their decreased obliquity usually regulates an increased obliquity in the whole limb downwards, or as is familiarly expressed, they stand with their legs under them. Unfavourable as is this form of the mare, both for the speed and safety of their action, it was given for advantageous purposes: for, by such a position in the fore extremities, the hinder are raised higher to afford additional security against the evils of gravitation and dislodgement of the foal from the pelvis. Few rules can be laid down in the exterior conformation that are more important, or of such general application, as that a short and upright shoulder, particularly when united with an

inclined direction of the whole limb backwards, is a sure mark of an unsafe goer, and commonly, though not invariably, of a slow one also. It now and then happens indeed, that horses having defective shoulders prove speedy and good movers, which would appear to contravene these principles; but it will be found, that, wherever horses having these defects in their fore legs yet prove quick and safe in progression, they invariably have hinder parts of great strength and proportion to make up the deficiency. Indeed, it appears probable, that the hind and fore parts do not bear the same relative proportion in all horses alike; in blood horses, the withers are not always high, and although their shoulders are commonly deep and oblique, yet the fore limbs are altogether short in proportion to the hinder, in a great number of the fleetest racers: for, as speed appears to be a principal end in their formation, and as comparative anatomy furnishes us with abundant proof that all animals destined to make considerable leaps (and the full gallop is nothing more than a succession of leaps) are low before, the end of their formation is really best answered by this arrangement of parts; it is also more than probable that, although speed in the gallop may be found with a defective forehead, yet, in the slower paces of the canter, trot, and walk, a justly formed shoulder is more immediately requisite. This subject will be still further elucidated when we treat on the mechanical properties of the skeleton.

6268. *The withers (e e)* are formed by the long transverse processes of the dorsal vertebræ (*fig. 830. y*), and as their use is to serve as levers to muscles, so their length characterised by the height of the withers must be of great advantage, and enable such horses to go high above their ground; for the muscles of the back, acting to greater advantage, elevate the fore parts more forcibly. From this we may also learn that the elevation of the fore parts, or the horse's going above his ground, as elevated action is expressed, is not altogether dependent on the motion of the shoulders, nor on the height to which the animal may be inclined to lift merely his legs; but likewise, on the extent to which the fore half of the machine is altogether elevated by the action of the dorsal and lumbar muscles. When the withers are high, or the forehead well up, as it is termed, it is favourable to the celerity and to the safety of the action; but as these properties are less wanting in the heavy breeds, we find in them a considerable variation of form: in the cart horse, weight of forehead is an essential requisite to his exertions; for drawing being an effort of the animal to preserve himself from the tendency which his weight gives him to the centre of gravity when he inclines forward, so the more weighty and bulky he is before, and the nearer he approximates this centre, the more advantageously he will apply his powers. It is not here intended to be hinted that nature gave him this form purposely to enable him to draw: this, indeed, would be an argument of necessity; but this form has been judiciously imposed on him by men, by regulation of the sexual intercourse, and by a careful selection of specimens having some of the requisites to propagate from, until at last we have produced the massive weighty animal whose powers astonish as well as benefit us.

6269. *The breast or counter (ff)* is the part between the point of the arms or shoulders, and which should be moderately wide and extended: when it is otherwise, the horse is seldom durable, or even strong, although he may be speedy; neither have the lungs sufficient room for expansion, nor the muscles great extent of attachment; frequently too it accompanies a general flatness of ribs, and want of circular form in the carcass in general; all which experience has shown to be necessary to the perfection of the machine. The breast may, however, be too wide; it may also hang over or project beyond the perpendicular of the fore limbs, so as to overweigh the machine: this form, however, though unfavourable to the saddle horse, for the reasons just assigned, is much desired in the heavy draught horse.

6270. *The back.* Where the withers end the back commences (*g*); the length should be moderate only, for a long cylinder cannot be so strong as one of less length; long-backed horses are easy because the action and the reaction are considerable; but what is gained in elasticity is lost in strength. When the back is too short, the extremities are so much approximated that they frequently overreach each other, and the hind foot strikes that before it, in progression: the back should be nearly straight, it has naturally an inclination in the line of its gravity; but this exists in very different degrees in different horses. When the incurvation inwards is considerable, such horses are called saddle-backed, and are usually considered weak; but, to keep up the counterpoise, the crest in such horses is generally good; they also ride pleasantly, and commonly carry much apparent carcass; sometimes indeed too much. When the back is curved upwards, it is called roach-backed; when considerably so, it is unfavourable to the liberty of action, as well as to the elasticity of motion: in these cases, to counteract the curve outward, the head is also usually carried low. A short-backed horse is in considerable request with many persons, who do not consider that when it is too much so there is seldom great speed; for the hinder extremities cannot be brought sufficiently under the body to propel the mass forwards.

6271. *The loins (h)* may be considered as the part which extends from immediately behind the hinder edge of the saddle, when properly placed, to the rump. Anatomically it begins at the sacrum (*fig. 830. z*), whose processes being sometimes defective or interrupted, leave an indentation, as though the union between the back and loins were incomplete; and such horses are said to be badly loined: but although it may in some measure deprive the muscles of some slight attachments, yet the evil is not so considerable as is imagined. The width of the loins is of considerable import to the strength of the animal, as it affords a greater surface for the attachment of the powerful muscles of the back and loins; and the muscles themselves should be so prominent, as to seem to swallow the back-bone amongst them. When the protuberances of the ilium or haunch bone are very prominent, the horse is said to be ragged hipped; but it operates to his disadvantage only in appearance, as extent in these parts, being favourable to muscular attachment, is always beneficial.

6272. *The croup* extends from the loins to the setting on of the tail (*n n*). It should be long and only slightly rounded, which is another characteristic of the blood or improved breed. In the cart horse, on the contrary, it is seen short and much more considerably rounded (*n n*). A long croup is in every point of view the most perfect, for it affords a very increased surface for muscular attachment, and although the large buttocks of the cart horse would at first sight convey an idea of great strength and extent, yet, attentively viewed, it will be found that the early rounding of the sacral line, the low setting on of the tail, and the small space which necessarily exists between the hips and buttocks, all tend to lessen the surface of muscular attachment, compared with the broad croup, wide haunches, and deep spread thighs of the blood horse.

6273. *The flank (k)*, is the space contained between the ribs and haunches; when too extensive it indicates weakness, because it is the consequence of too long a back; and such a horse is said not to be well ribbed up. When the transverse processes of the lumbar vertebræ are short, as in badly loined horses, this part is hollow. The flank is usually looked to also as indicative of the state of respiration: thus, when it rises and falls quicker than ordinary, unless violent exertion has just been used, it betokens present fever, or otherwise, chronic disease of the lungs.

6274. *The belly (i)*. Having taken a tour round the upper parts of the carcass, we will carry the survey downwards and forwards. Anteriorly, the ribs should be wide upwards, and as much deepened below as possible, which affords what is termed great depth in the girth. This form greatly increases the surface of attachment of the motive organs, the muscles, and also allows room for the free expansion of the lungs, and consequently is favourable to the wind. Posteriorly, the ribs should form the body as much as possible into a circular figure, that being of all others the most extended, and affording the best surface for the absorption of nutriment; thus barrelled horses, as they are termed, are greatly esteemed, and found to be lasting in work and readily brought into condition, and more easily kept so. When the chest is too flat and straight, the belly is also small: hence, neither can the blood absorb its vital principle from the air, nor the lacteals the chyloferous juices from the intestines; these horses are therefore seldom durable. As less nutriment is taken up by the constitution, so less is eaten, thus also they are seldom good feeders;

and as the pressure on the intestines must be considerable from the small containing surface, so they are usually likewise what is termed washy; that is, easily purged, whereby an additional cause of weakness exists, from the too early passing off of the food. Such horses are, however, very commonly spirited and lively, although not lasting. A knowledge of the advantages gained by a circular form of carcass or belly, as affording the greatest capacity, is what constituted Bakewell's grand secret in the breeding of cattle: he always bred from such animals as would be most likely to produce this form, well knowing that no other would fatten so advantageously.

6275. *The whirlbone (l)*, among the jockeys and grooms, is the articulation of the thigh bone, with the pelvis, or basin, and forms the hip joint. The ligaments of this powerful joint are sometimes forcibly distended by violence, and a very obstinate lameness is usually the consequence. The situation of the thigh (*l, m*) is in the horse, as in most quadrupeds, enveloped within the range of the trunk.

6276. *The stifle (m)* corresponds with the knee of the human figure, and is the point at the lower portion of the flank. It is evident that the part below this, which is generally called the thigh or gascoin, is erroneously so named. It should be very muscular and extended; it should also make a considerable angle with the femur or thigh, and form a direct line under the hip or haunch. Its length in all animals destined for speed is considerable.

6277. *The fore extremities or legs.* In treating of the mechanical properties of the skeleton, we shall have to point out the essential differences between the geometrical structure and functions of the fore and hinder extremities. We shall here content ourselves with a simple examination of the individual parts.

6278. *The arm of the horse (b)* is apt to be overlooked, nor, without some consideration, does it strike the observer, that the arm covered with muscles, and enveloped within the common skin of the chest, extends from the elbow (*a*) to the point of the shoulder, as it is termed, but correctly to its own point below and before the shoulder blade. (*fig. 830.*) The same reasons which render a muscular, oblique, and deep shoulder advantageous, also make it desirable that this part should be muscular and extensive in length and breadth, and that its obliquity should be proportionate to that of the shoulder: whence it results, that the more acute the angle between them, the greater will be the extent of the motion gained by the flexion and extension of the parts.

6279. *The fore arm (c)*, which horsemen consider and call the arm, is placed upright to counteract the angular position of the real arm and shoulder bones. As it is always found long in animals destined for great speed, as we witness in the hare and greyhound, it should therefore be also of considerable length in the horse, when speed is a requisite quality; but for the cadences of the manege, where the elasticity is required to be distributed equally through all parts of the limb, it is chosen short. The fore-arm is broad and large, particularly upwards, for here the powerful muscles that operate the motions of the parts below, are almost all of them situated. To prevent incumbrance, and to give solidity, these muscles degenerate into tendons and ligaments below the fore-arm; but above, it is essentially necessary to strength that they should be large and well marked.

6280. *The knee (d)*, so called, is properly, with reference to human anatomy, the carpus or wrist. It is composed of many bones to enable it to resist the jar arising from the action of the perpendicular parts above and below it. All the joints of the extremities, but particularly those of the knee and hock, should be broad, that the surface of contact may be increased, and the stability augmented; by this means, likewise, a more extensive attachment is afforded to muscles and ligaments; their insertions are also thereby removed farther from the centre of motion.

6281. *As criteria of safe going, the knees should be particularly examined* when it is contemplated to purchase a horse, to see whether the skin has been broken by falls; and in this, very minute attention is required; for sometimes the wound heals so perfectly, or otherwise so much art is used in shaving the hair, blistering, colouring, and rubbing it down, picking out the white or staring hairs, &c., that more than common nicety is required to detect a slight scar. It is, however, prudent to remember, that it is not every horse whose knees betray a scar, that is a stumbler: the best may have a fall in the dark. It is also necessary to caution persons against the admission of a very common prejudice, that when a horse has once been down, however little he may have hurt his knees, he is rendered more liable than before to a similar accident. If his limbs have not been weakened by the accident, or if the cicatrix be not sufficiently large to prevent the free bending of the knee, he is not at all more liable to fall than another horse. If, therefore, a horse with a scar on his knee have the forehand good, and if his action correspond thereto, he ought not to be refused on this ground: but with a different conformation he ought to be steadily rejected, let the tale told be ever so plausible. In gross heavy horses a scabby eruption often seats itself around the inner bend of the knee (*h*), which is called mallenders.

6282. *The canon or shank (e)* carries the limb down elegant, light, straight, and strong. Much stress is deservedly laid on the necessity that this part of the limb should be wide when viewed laterally. Viewed in front, its being thin is favourable, because made up as it is principally of bone and tendon, any addition to it beyond these must arise from useless cellular matter, or otherwise from matter worse than useless, being placed there by disease. Any thickening of the part generally or partially, should be looked on with suspicion; as, if natural, likely to interfere with motion without adding to strength; or if accidental, as a mark of acquired injury likely to remain. In the bony skeleton may be seen within and behind the knee an apparatus destined to remove the acting ligaments and tendons from the centre of motion, by which great advantage is gained in strengthening and facilitating their flexions. It is a default in this conformation that renders horses *tied in under the knee*, as it is usually termed. The limb below the knee, instead of proceeding downwards of a uniform width, is seen suddenly narrowing immediately as it leaves the knee. Such horses are invariably found to bear exertion badly; their legs at an early period become bowed or arched, and totter on the slightest exertion. In cart horses this conformation is very common; but in them it is of less consequence than in those destined for quicker motion, where the elevation of the limb is so extensively and so frequently repeated. To render this subject familiarly clear, we will recommend that a cord be placed round the ball of the thumb, and passed up close to the arm until it reaches the bend: with the other hand, by straightening and extending this cord, but held close to the arm, endeavour to flex the hand and wrist inwards: operated in this way it will require great force to do it; but remove the hand only two inches from the arm, and the bound hand will yield readily to a less force. Exactly the same happens to the ligaments and tendons called back sinews which flex or bend the fore legs; for by an apparatus, formed from the position of one of the carpal bones (*pisiformis*), they are, in well formed legs, set out wide from the knee.

6283. *The back sinews* should not only be large and firm, but they should, like the limb generally, be very distinct from the knee to the fetlock: in this course, if any thickening be observed, it betokens former injury, as extension or rupture of ligamentous fibres, which usually have a disposition to recurring weakness. If a hard swelling appear on the inner side, not on the tendon, but on the bone, a splint is present which is more or less injurious as it is nearer or farther from the knee, or distinct from or situated among the tendons and ligaments; but when it is considerable in size, hot to the feel, and extends inwards and backwards among them, it usually produces most injurious consequences. To detect these evils the eye alone should not be trusted, particularly where there is much hair on the legs, as on cart horses, and even on hackneys in the winter, but the hand should be deliberately passed down the shank before and behind. An enlargement or scar situated close to and on the inner side of the knee, must not be mistaken for a splint; it more frequently arises from a custom some horses have when trotting fast, of elevating their feet and cutting this part with their shoes, and it is thence called the *speedy cut*.

6284. *The pastern and fetlock (ff).* General usage has applied the term fetlock to the joint itself, and pastern to the part extending from the fetlock to the foot; properly speaking, the fetlock or footlock is only the posterior part of the joint, whence grows the lock or portion of hair, which, in many horses, flows over and around the hinder part of the foot; a short and upright pastern is inelastic, and such horses are uneasy goers; they are unsafe also, for the pastern being already in so upright a position, requires but little resistance, or only a slight shock, to bring it forwards beyond the perpendicular; and the weight of the machine then forces the animal over. Nor are these the only evils arising from this formation, for the ends of the bones being opposed to each other in nearly a perpendicular direction, receive at each movement a jar or shock, which leads to an early derangement of the joint, and to the appearance called overshoot. On the contrary, when the pasterns are too long they are frequently too oblique also; and although their elasticity may be pleasant to the rider, such formation detracts from the strength of the limb. These joints both before and behind are very subject to what is called windgalls, which are swellings formerly supposed full of air, whence their name; but they are now known to contain an increased quantity of the mucus destined to lubricate the parts in their motions. These puffy elastic tumours are originally small and hidden between the lower end of the canon and the flexor tendon, or back sinew; but when hard work has inflamed all the parts, the secretion within increases, and then they become visible to the eye; but unless they are so considerable as to obstruct the due action of the parts, they are no otherwise objectionable than as they tell a tale of inordinate wear of the limbs generally.

6285. *The form of the pasterns influences the defect called cutting,* which arises from a blow given to either the fore or hind fetlocks by one leg to the other during its elevation. Horses narrow in the chest, or which turn their toes out, or have other peculiarities of form, cut permanently, and are then very objectionable; but others only cut when fatigued, or when very low in flesh. Horses often cut when young, who leave it off when furnished, and of mature growth.

6286. *The feet (g g).* These essential and complex organs will be more fully examined in the anatomical detail, but much also presents itself to the consideration in an exterior examination. Horses might be presumed to be naturally born with perfect feet; but experience shows that defects in these organs are hereditary. In some, the peculiarities of climate operate; and in others, a constitutional predisposition exists; dependent on some cause with which we are unacquainted.

6287. *Climate influences the form of the horse's foot.* In the arid plains of the east, where every impediment to an extensive search for food is removed, the feet are hard, dry, and small; this form, notwithstanding the alterations of breed and culture, in some degree still adheres to the blood or aboriginal eastern horse: artificial habits have extended the evil, and now small and contracted feet are to be seen in every variety, except in the coarse heavy breeds.

6288. *Constitutional and hereditary causes operate on the feet.* That a constitutional predisposition exists in the production of a particular form of foot, we know from the fact, that dark chesnut horses are more prone to contraction of the hoofs than any other coloured horse; and that the form of the foot is hereditary, may be gained from the known circumstance that some of the Lincolnshire stallions always get large flat-footed progeny; while some full bred entire horses entail small upright feet on all their offspring.

6289. *Local situation will also affect the form of the feet.* The effect of situation is remarkably exemplified in the horses which we used to obtain from Lincolnshire, Cambridgeshire, and some parts of Norfolk and Yorkshire, before the draining system was perfected. These horses had, almost invariably, large, flat, heavy feet; which, however convenient and natural they might prove to the animals while moving on the qaggy surface of marshy districts, yet were found very unfit for quick light movements in drier situations. Such horses go heavily and stumble: and as the horn of which these enormous feet are formed is always weak, the anterior or front part yields to the heat and inflammation brought on by exercise on hard roads, and falls inwards, which letting the weight of the body fall on the soles pushes that downward; and at last from a concave, it presents a convex surface. The feet cannot then bear shoeing, but with much art and difficulty: pain and tenderness bring on lameness and uselessness; and therefore horses with such feet should be rejected. Feet preternaturally small are equally objectionable, as betokening a disposition to contraction. Horses with a tendency to foundered feet stand with pain in the stable, first placing one foot before, and then shifting it to place the other in the same situation. The contraction usually begins in the heels, which are found higher than natural, and drawn inwards; the foot altogether is likewise narrower, and the sole hard and hollow. When a preternatural fulness is seen around the coronets, *ring-bone* may be suspected; and if heat and hardness be accompanied with any tenderness in going, its existence is certain. But although too much horn is to be avoided, too little produces a weak foot; in which the heels, quarters, and soles all participate: the thin horn cannot resist the impressions of the stones on the road, and then lameness ensues. The under surface of the foot should exhibit a full, healthy, wide frog, with bars prominent and properly inflected. The concavity of the sole should be particularly attended to; when less than natural, it is weak, when more, it indicates contraction; whence such feet have been called too strong. White feet are objectionable, because they are found more liable to this evil than others. *Corns* are an evil to which the under surface of the foot is liable, and which should always be looked for on the purchase or examination of a horse; for which purpose, it would be well that the fore shoes should be removed, and the foot carefully pared by a judicious and clever smith. Merely picking out the foot will often, also, detect the remains of former cuttings or parings out of the corns. Some hoofs are very brittle, and a horse with this defect should, in every instance, be rejected. The evil may in general be easily detected by the marks of the fragile parts detaching themselves from every old nail-hole. This kind of foot, particularly in hot weather, breaks away till there is no room for the nails to hold; when the horse of course becomes useless. *Sandcracks* are also another evil to which the feet are liable; and which should engage the attention in the examination of a horse: they consist of longitudinal fissures; one only is usually present at once; but that one if deep is fully equal to produce lameness. The subject of the feet will be concluded by an observation on their general appearance, well worthy of attention. The eye should be directed to the degree and to the manner in which the shoes are worn; which will often save much useless trouble in trying a horse. A stumbling horse may be frequently, nay commonly, detected by simply lifting up one fore foot: for the unequal wearing away of the shoe at the toe, while the other parts remain good, is a full proof of his going unsafely and *digging his toes*.

6290. *On a review of the conformation of the fore extremities,* it may be remarked, that whereas the hinder may be considered as more particularly concerned in impelling the machine forwards with its requisite velocity; yet, that upon a proper form and a true direction of the various component parts of the fore limbs must depend the stability, the truth, and the safety of the movements. Viewed anteriorly, the fore legs should stand rather widest at the upper part, inclining a little inwards below; but when we view them latterly, they should present a perpendicular from the arm downwards; and the toe should place itself directly under the point of the shoulder, as it is called. If the foot should stand beyond this, which is seldom the case, the action will be confined, for the limb will have already passed over a point of its ground; such a horse, however, generally treads even, flat, and safe; and, in proportion as it stands in the direct line downwards, he generally inherits these desirable properties. When the foot stands behind the perpendicular line the defect is considerable, by the removal of the centre of gravity too much forward, by which an increased tendency to stumble and fall is entailed; and as this in general accompanies a want of extent and obliquity in the shoulder, so it likewise lessens the speed.

6291. *The hinder extremities.* We have already described the thigh, correctly so

called, which is so concealed by muscles as frequently to escape this consideration of it, by which the part immediately below it popularly receives the name of thigh, but which is, in fact, the leg.

6292. *The leg* (1, 2), commonly called *the thigh*, in well formed horses is powerfully furnished with muscles, and very extended in its figure; it should also make a considerable angle with the femur or real thigh, and form a direct line under the hip or haunch; for the same reasons that make it desirable to have a long arm in the fore extremities, it is also advantageous that the leg should be so likewise, and this is the form usual among all quadrupeds of speed.

6293. *The hock* (2) is the important joint immediately below the leg, or thigh commonly so called, and is interposed between the tibia and tarsal bones (*fig. 830.*), purposely to increase the extent of attachment, and to break the shock of great exertion; it may be considered as the most complex and important joint of the body: like the knee, it should be extended and broad; for, in proportion as the calcaneum or point of the hock (5), and which is the real heel, extends itself beyond the other bones, so the powerful tendo Achilles inserted into it, acts with a longer lever, and with a greater increase of power. This joint is subject to several important diseases, which, in the examination of a horse, require particular attention; when a soft puffy swelling is discovered in the ply or bend of the hock (3), it is termed a *blood spavin*, which will be noticed among the diseases; it is, in fact, a similar enlargement with the windgalls before mentioned, and what has been said on them equally applies to these. When similar mucous capsules become enlarged on each side of the hock, the enlargement receives the name of *thorough-pin*. A small bursal enlargement is sometimes found at the very point of the hock (5), and is then called a capulet; to all which what has been said on windgalls applies, that they are only to be deemed of consequence when so large as to interfere with the motion of the parts they are situated with or near; or, as indicative of an undue portion of work. The ligaments at the back of the hock sometimes become strained or extended, and heat, inflammation, and swelling follow, which is then called a *curb*. As rest or very mild treatment soon reduces it, it is not to be considered as of great consequence. The inner part of the joint at the ply or bend, is sometimes attended with a skin affection similar to the mallenders before alluded to, and is called *sellenders* (4); but the most serious disease to which the hock is liable, is a disease of the ligaments of some of the tarsal bones. Sometimes one or more of these bones, or the ligaments which unite them, inflame, and an exostosis or *splint* is formed: to detect the existence of this affection, the hocks should be attentively viewed from behind, when any enlargement in the spavin place (3, 4) may be easily detected. The mechanism of this joint will be further considered when we treat of the skeleton generally.

6294. *The colour of horses* does not depend on their real skin, as with man, but upon an exterior beautiful covering which nature has given them, called *hair*; nevertheless, the hair is, in some measure, influenced by the skin, as light-skinned horses have light hair, and when the hair is light, the eyes are usually so likewise: hair presents many varieties of tint, so horses are said to be of various colours. Buffon has conjectured that horses were originally of one colour, which he presumes to be bay; but such wild horses as have been seen, and which have been supposed to be pure originals, have not justified this opinion. This same author has divided the colours of the horse into simple, compound, and strange or extraordinary.

6295. *The simple colours* are bay, chestnut, dun, sorrel, white, and black; *bay* is a very prevailing tint among European horses, and admits of many shades, but is admired in all: there are bright bays, blood bays, dark and dappled bays; *brown bay* is a very esteemed colour, and consists of bay and black in unequal proportions in different horses: *brown* horses are highly prized; the darker varieties have usually beautiful tan markings, as about the muzzle, &c.: they have commonly also black manes and tails, with legs and feet of the same hue; and it may be here remarked, that horses of compounded colours, of whatsoever tint the mane and tail may be, will be found invariably formed of one of the compounding colours; thus light greys, which are a compound of black and white, have often white manes and tails: sorrels, again, which are formed of white, with a small proportion of red, have also frequently white manes and tails: *chestnut*, which is also a very common colour, admits of almost as many shades as the bay, from the lightest tint to the deepest tone. Very light chestnuts have frequently still lighter manes and tails, with mealy legs and light feet; so marked, they are certainly not to be chosen for strength, durability, or pliancy of temper: the Suffolk punch, however, may be considered in some degree an exception, although the true breed is hardly so light as those hinted at here. Dark chestnuts are considered, and with justice, as fiery in their dispositions; they are also more subject to contracted feet than horses of any other hue. *Dun* is a colour that has several varieties; it is sometimes accompanied with a white mane and tail, at others they are seen even darker than the rest of the hair. In some, a list or line of deeper tint extends along the back, which is regarded by some as an indication of hardihood: a similar line is sometimes seen in the bay. Dun horses do not appear to be at all influenced in their qualities by their colour, or rather no criteria are offered by it, for there are good, bad, and indifferent in all the varieties of shade. The *sorrel* is a variety of the chestnut, but not a favourite one. *White* as a native colour is not in much estimation, neither is it very common, for many horses are white only through age, as all light-grey and flea-bitten horses become so. *Black* is a very usual colour, and in the large heavy northern breed it seems to be an original tint; and perhaps it is to this their goodness may be attributed, for, among the lighter breeds, there are more indifferent black horses than of any other colour. The tempers of black horses are commonly in the extreme, either sluggish to stupidity, or fiery to excess. The colour itself admits of many shades; but a perfect black horse is more unusual than it is generally thought to be: a star on the forehead is common to relieve the ebon hue; and in the absence of that, a few white hairs on the breast frequently interrupts the uniformity. It is, perhaps, on this principle that black horses have white legs so often as they do.

6296. *The compound colours* may be considered as those in which the hairs are compounded, but not the colours themselves; otherwise the bay, the chestnut, brown, &c. might be considered as compounded colours. The *roan* is a mixture of red and white: its varieties are the common, the red, and the dark. All the roans are esteemed. *Grey* admits of a great number of shades and varieties, but all are compounded of black and white, except the iron grey, which receives a few bay hairs among the black and white; a considerable prejudice exists in favour of this colour. Greys are light or dark; there are also the dappled, the markings of which are extremely beautiful, and the silver grey. Grey horses become lighter by age: many old white horses have been grey until age overtook them. Grey horses, like black, admit of no settled character; though, unlike them, they are not to be generally disapproved of. They have, however, all the extremes within their range; the darker ones are usually good, the lighter ones not generally so.

6297. *The extraordinary colours* are not very numerous, and it may be remarked, that white is always the relieving tint, intermixed with distinct markings, in various proportions, of bay, brown, black, or chestnut. *Flea-bitten* is grey or white, with small bay spots. When these spots are very large, and have a marginal surface of lighter markings, they give the name *tiger coloured*; and although they are uncommon with us, they are not unfrequent in Germany and Barbary. Pied or pie-bald is one of the most numerous extraordinary colours, and is usually composed of two colours, in distinct large markings,

Now and then a third interferes: there are pies of all original colours with white, and all are held in estimation.

6298. *Colour, as a criterion of mental and personal qualities*, is laid much stress on by many persons, and long experience has shown that certain tints are usually accompanied by certain qualities of person or disposition. As a general rule, dark-coloured horses are certainly the best; but, as before observed, it is peculiar that black, as the darkest of all, should form an exception to this rule. Light shades appear unfavourable to strength and durability; they are also accompanied frequently with irritability and perverseness of temper. Something like a general law in the animal economy seems to prevail, to make white a distinctive mark of weakness. Age, which is the parent of weakness, brings with it white hairs, both in man and in horses, and most other quadrupeds. The hair formed after a wound has robbed a part of its original covering is often white, because the new formed surface is yet in a state of debility. It is likewise a fact well known among the observant, that the legs and feet when white are more obnoxious to disease than those of a darker tone. The Arabs remark, that light chestnut horses have soft tender feet. It is the observance of these peculiarities that has at length guided our taste, and formed our judgment of beauty. With us much white on the legs is considered as a deformity, and is expressively called *foul marked*, whereas pied markings in other parts are reckoned beautiful. In Africa, however, Captain Lyon informs us a superstitious dependence is placed on horses with legs and feet stockinged with white. It does not appear that climate has the same influence on the colour of horses as on that of other domesticated animals. In all latitudes in which the horse can live, he is black or white indiscriminately; but as he cannot endure extreme rigour, it is not necessary that he should vary.

SECT. III. *The Bony Anatomy or Osseous Structure of the Horse.*

6299. *All quadrupeds* are formed on an earthy base called bone, and the assemblage of bony parts is called a skeleton. Bones are formed of earth and membrane (1881.); they are covered also by an investiture called periosteum. The earthy part is the last formed, and consolidates the bones as the animal becomes fitted to exert all his powers. This deposit of earth in the bones appears to be hastened by any thing that permanently quickens the circulation: heat does this, and hence the human and brute inhabitants of warm climates come to perfection sooner than those of northern regions; but they are generally smaller, for by preternaturally hastening the earthy deposit before the membranous part of the bones becomes fully evolved or grown, they do not attain the bulk they would be otherwise capable of. Undue exertion has the same effect; and thus we learn why horses too early and too hard worked become stunted in their growth. Pressure likewise occasions an early, and also a preternatural ossification: in this way the parts of the spine which bear heavy loads present large masses of bone, brought on by this cause alone. For the same reasons, horses early worked put out splints, spavins, and other bony concretions. Bones are all of them more or less hollow: within their caverns an oily fluid is secreted, called medulla or marrow, which serves for their support, and that of the constitution generally. The bones have nerves, blood-vessels, and absorbents. Bones are capable of reproduction, as proved by their uniting when broken; and also by the yearly renewal of the antlers of the deer, which are not horn as in the ox or sheep, but pure bone. Bones are connected together by *articulation*: when such articulation is moveable, it is termed a joint. In some cases bones articulate by suture or indentation of parts, as in the skull. We shall consider, in succession, the anatomy of the head, trunk, and extremities.

SUBSECT. 1. *Osseous Structure of the Head.*

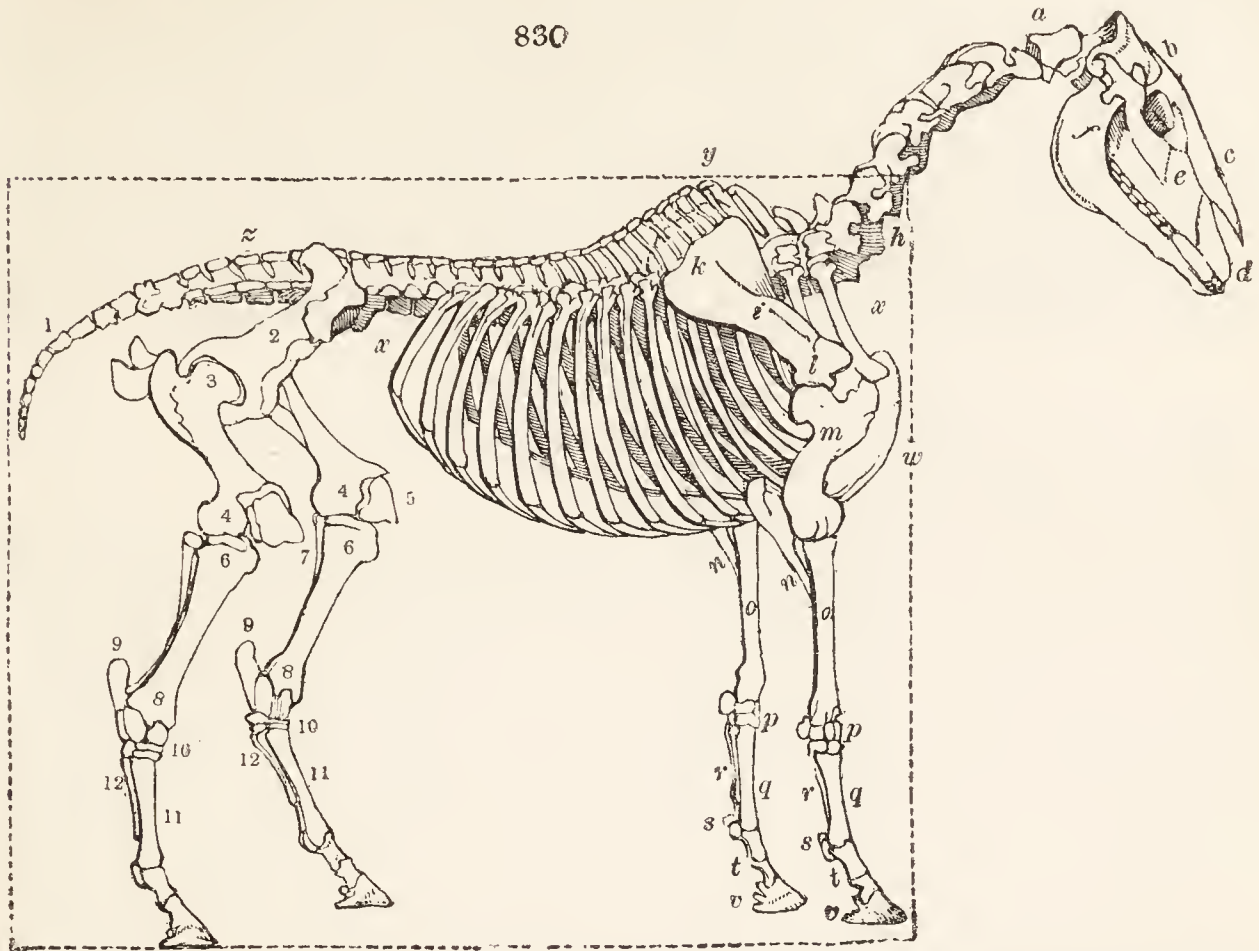
6300. *The bones of the head* are as follows. The *occipital* (*fig.* 830. between *a* & *b*), which is the largest bone of the skull, in the colt is composed of several pieces which unite by age; it articulates with the atlas (*a*) or first of the cervical or neck vertebræ. At its posterior surface it is perforated by a large hole, which gives passage to the spinal marrow. The two *frontal* bones (*b*) unite also by age; and behind them is lodged the anterior and inferior portion of the brain. A division of their bony surfaces forms two cavities called the frontal sinuses, which are lined by the nasal membrane throughout. The sagittal suture unites these two bones. The remainder of the bones of the skull are the *two parietals*, the *two temporals*, divided into a squamous and petrous portion, within the latter of which is situated the internal ear; and to the former the posterior or lower jaw articulates. The *sphenoid* and *ethmoid* bones are hollow and irregular, serving to intersect and attach the others; and also to assist by their cavities in extending the pituitary or smelling membrane.

6301. *The bones of the face* are ten pairs and two single bones. The *nasal* (*c*) pair, within their union, hold the septum narium or long cartilaginous plate which separates one nostril from the other. These bones also greatly assist to extend the surface of the smelling organ. In the old heavy breeds, it was very common to see these bones arched outwards; but in the improved breed, particularly in those approaching full blood, it is not uncommon to find them slightly curved inward. The fossæ within these bones are the principal seat of glands. The two *angulars* form a considerable portion of the orbits of the eyes. The two *malar, jugal, or cheek* bones occupy also a portion of the orbits. The *superior maxillary* bones (*e*) are the largest of the face bones, and contain all the upper molar teeth. The *inferior or intermaxillary* bones (*d*) are wanting in man, in whom the face is short: these bones concur with the former in forming alveoli or sockets for lodging the teeth. The *superior palatines*, the *inferior palatines*, the *pterygoids*, the two *anterior*, and the two *posterior turbinated* bones, with the *vomer* or *ploughshare*, make up the remaining facial bones, with the exception of the *posterior maxillary* or *lower jaw* bone (*f*), which on its anterior edge is pierced to lodge the teeth; at the upper part it extends itself into two angular branches, each of which ends in two processes and an intermediate groove. The superior of these processes articulates with the upper jaw. This bone throughout shows the most admirable mechanism; the molar or grinding teeth, on which most is dependent, and whose exertions are greatest, are placed near the centre of motion: and as the upper jaw in most animals is fixed, or nearly so, it was necessary that the lower should have considerable extent of motion for the purpose of grinding; and it is accordingly so formed as to admit of motion in every direction. The *os hyoides* is a bone situated within the head at the root of the tongue, to which it serves as a support, and for the attachment of muscles.

6302. *The teeth* of the horse are the hardest and most compact bones of the body. There are usually forty of them in the horse, and there are thirty-six in the mare; in which latter the tushes are usually wanting. In anatomical language, they are divided into *incisores cuspidati*, and *molares*, or according to the language of farriers and horsemen, into twelve *nippers* (*fig.* 829. *a, b, c*), four *tushes* (*dd*), and

twenty-four *grinders*, which numbers are equally divided between the two jaws. The teeth are inserted into indentations or sockets between the bony plates of the jaw, called *alveoli*, by cone-like roots. The bodies of the teeth are principally composed of two substances, one of the nature of common bone, giving bulk and form, and one of extreme hardness, called *enamel*, placed in man and carnivorous animals wholly

830



without the teeth, to give strength and durability; but in the horse and other *Gravivora*, the latter particularly, it is placed in the *grinders*, in perpendicular plates, within the body of the teeth; by which contrivance, a rough grinding surface is kept up; for the mere bony parts wearing faster than the *lamellæ* of enamel, it follows that ridges remain to triturate the vegetable matter that passes between the teeth.

6303. *There are two sets of teeth*, a temporaneous or milk set, and a permanent or adult set, in which wise provision man and most brutes participate. The milk set are some of them, as the molars, apparent at birth; there being usually six *grinders* in each jaw, three on each side in the new-born foal, and which number of this set is never increased. The nippers begin to appear soon after birth, and follow a regular order of succession until the animal is three or four months old; at which time he begins to require support from herbage as well as milk. The temporaneous set remove gradually one after another; had they all been displaced at the same time, or even had several of them fallen out together, the animal must have suffered great inconvenience, and perhaps have been starved. This removal, which commences at the age of two years and a half, and is completed between the fourth and fifth year, is effected by the action of the absorbents on their fangs, and appears to be occasioned by the stimulus of the pressure received from the growing teeth under them. For although these two sets appear with an interval of some years between them; yet the rudiments of both are formed at nearly the same period, and both sets may be thus seen in a dissected jaw. Regulated by the stimulus of necessity, as soon as the temporaneous set falls out, the permanent appears: and that such appearance follows the necessity is evident; for a premature or accidental removal of the colt's teeth is soon followed by the appearance of the others. Dealers and breeders, aware of this, draw the milk teeth to make their colts appear as horses. It was necessary there should be two sets of teeth; for, as they grow slowly in proportion to the jaws, had there been but one only, the disproportion of growth between the teeth and jaws must have separated them.

6304. *The forms of the teeth vary more than their structure.* The incisive or nippers are round, which is favourable for the pressure they undergo; the upper more so than the lower. On the upper surface a hollow is seen in the young tooth, which, not extending through the whole substance, naturally wears out with the wear of the tooth; and as a considerable degree of regularity occurs in this wearing away in all horses, it has gradually settled into the general criterion of age. The nippers are not all of them exactly similar; the corner teeth differ most in being nearly triangular, and in having an internal wall or side, which does not become level with the rest until long after those of the others. The cuspidate tusks or tushes are permanent, appearing at about five years or rather earlier; those in the front jaw are usually nearer the nippers than those below. Each presents a slight curve, which follows the direction of all the canine or pugnatory teeth of other *Mammalia*. The pointed extremity wears away by age, leaving merely a buttoned process, which may serve as a guide to the age when a horse is suspected to be *Bishoped*, as it is called, from a man of that name who was peculiarly dexterous in imitating on old teeth the distinctive cavity of youth. The molar or grinding teeth are stronger in the upper than in the lower jaw; which was necessary, as they form the fixed point in the process of grinding. The upper surface presents nearly a long square, indented from the alteration of the enamel with the bony portions; and as the interior or upper teeth hang over the posterior, so the ridges of the one set are received into the depressions of the other.

6305. *Wear of the teeth.* The teeth, in a state of nature, would probably present a surface opposed to each other for mastication, to the latest period of the most protracted life; but the removal of the animal from moist food to that which is hard and dry, must occasion an unnatural wear in those organs; and hence, although the teeth of the horse, even in a domesticated state, are not subject to the caries of the human; yet the *grinders* are liable to become thus injured by continued exertion. In the young or adult horse, the upper and under *grinders* do not meet each other horizontally; on the contrary, they have naturally an inclination obliquely inwards; and those of the upper jaw present small spaces between each other, while those of the lower are more continuous; by which means, as the food, particularly its interrupted portions, as grain, becomes ground, it falls within the mouth to be replaced under the grinding sur-

face, if necessary, by the joint action of the tongue and muscles of the cheek. This arrangement becomes in a great measure frustrated in old horses, by the superior wear of the inner surface of the upper grinders, as well as by the general misapplication of the surfaces of both upper and under teeth, by constant attrition, when worn down nearly to the gums. The unfortunate animal feels sensible of this, and endeavours to remedy it by throwing the wear on the outer edge, by an inclination of the lower jaw and of the head in general; and which is so particular in its appearance as to engage the attention of the by-standers. This defect may be in a considerable degree remedied by casting the animal, and having opened and wedged the mouth so as to keep it so, removing the inequalities with a well tempered concave file, as much as may be. When the defect is considerable, and the horse is mild and quiet, it is better to file the inequalities every day, which will gradually but effectually wear them down. It however happens, that the inclination thus to wear is commonly resumed, and gradually the same loss of nutriment takes place: in which case, soft moist food, as carrots, mashes, soiling, or grazing, must be substituted for harder substances, and if corn be actually necessary, let it be bruised. Whenever an old horse betrays symptoms of want of condition, or weakness, and emaciation, that neither his mode of feeding, nor his ratio of work will account for, and particularly if whole grains should be found in his dung, his teeth should be examined carefully. This undue wearing of the teeth occasions another evil often, which is ulceration of the cheeks, by reason of the projecting ragged surface of the uneven teeth, which can only be remedied by the removal of such portions. These projecting portions are called by farriers *wolves' teeth*.

SUBJECT. 2. *Bony Anatomy of the Trunk.*

6306. *The trunk of the skeleton* consists of the spine, the pelvis, and the thorax or chest, composed of the ribs and sternum.

6307. *The bony column called the spine* is made up of seven cervical, eighteen dorsal, six lumbar, and five sacral *vétebræ*, with the addition of thirteen or fourteen small tail-bones. The spinal bones are thus divided on account of the varieties they present; they have, however, some characteristics in common. Each is composed of a spongy bony body, with protruded points called processes, which processes unite, to form a hollow through which the spinal marrow is transmitted; and by some of these processes the *vétebræ* are articulated with each other, as well as by their bodies, by which their strength as a column is much increased. Though but little motion exists between any two *vétebræ*, yet the flexibility of the whole spine is considerable.

6308. *The cervical or neck vétebræ* (*g, h*) are called, by farriers and butchers, the rack bones. It is remarkable, that, let the neck be long or short, the number of bones is the same in most quadrupeds. The first and second differ from the rest in figure, and present some other peculiarities. The first is the only one of them to which the great suspensory ligament of the neck does not attach itself, which would have interfered with freedom of motion. It articulates with the second by receiving its tubercular process within it, and from which process the second of these bones has been called *dentata*. Between these two neck bones is situated a part, where the spinal marrow is exposed from any bony covering; at which part butchers plunge a pointed knife into what they call the pith of the neck, when they want to kill their animals instantaneously, and without effusion of blood; whence it is called pithing. The remaining five neck bones are not very dissimilar from each other.

6309. *The dorsal vétebræ* (*y*) are now and then, though rarely, nineteen in number; they do not differ materially from each other, but in the length of the spinous processes of the first seven or eight. It is to these elongated spines that we owe the height of the withers; and as the intention of these parts seems principally to serve as levers for the muscles of the back inserted into them, so we can readily understand why their increased or diminished height is favourable or unfavourable to progression. These like the former articulate with each other by processes, as well as by the anterior and posterior surfaces of their bodies; between each of which is interposed a substance, semi-cartilaginous in its structure, which is most compressible at its sides, these permitting the motion of the spine.

6310. *The six lumbar vétebræ* differ from the foregoing in having a longer body, and very long transverse processes to make up for the deficiency of ribs in the loins. These bones often unite by the pressure of heavy weights, and sometimes spontaneously by age, and thus we need not be surprised at the stiffness with which some old horses rise when down.

6311. *The five sacral vétebræ* (*z*) are united into one to give strength to the column, and to serve as a fixed support to the pelvis, or basin, with which it is interwedged. From this detail it will appear how admirably this spinal column is adapted to its important functions of serving as a flexible but powerful support to the machine; and how by the formation of a large foramen within the substance of each *vétebræ*, a bony canal is offered for the safeguard of the spinal marrow, from which, through lateral openings in these *vétebræ*, the spinal nerves are given off in pairs. *The pelvis or basin* (2) is composed of the sacrum, the two *ossa innominata* and *coccygis*. The *ossa innominata* in the foetal colt before birth are each composed of the ilium, the ischium, and the pubis, all traces of which division are lost before birth. The *ilium* is the most considerable, and forms the haunches by a large unequal protuberance which, when very prominent, occasions the horse to be called ragged-hipped. The next largest portion is the *ischium* or *hip bone*, on each side. It forms a part of the cotyloid cavity, or cup for the thigh bone, and then stretches back also into a tuberosity which forms the points of the buttocks. The *pubis* or *share bone* is the least of the three: in conjunction with the former it forms the *acetabulum* or cup-like cavity in which the head of the thigh-bone lodges. The pelvis or basin is attached to the sacrum by ligaments of immense strength; but it has no bony union, by which means, as in the fore extremities, some play is given, and the jar of pure bony connection is avoided. The *ossa coccygis*, or bones of the tail, vary from eight to sixteen, but are very commonly thirteen or fourteen.

6312. *The thorax or chest* comprises the sternum or breast bone, and the ribs. *The sternum* (*w*) of the horse is inclined like the keel of a ship, to which the ribs are attached by strong ties. The *ribs* (*xx*) are usually eighteen to each side, of which eight articulate with the sternum, and are called *true*, while the remaining ten, uniting together by intervening cartilages, are called *false ribs*. The centrals are the longest, those anterior, as well as posterior, are less so: the first is placed perpendicularly, the second less so; and their obliquity, as well as dimensions, increase as they advance, so as to enlarge the chest to an almost circular form, which is the most desirable; but when they are less arched, the belly partakes of the defect, and a flat-sided horse is commonly a bad carcased one also.

SUBJECT. 3. *Bony Anatomy of the Extremities.*

6313. *An examination of the bony parts of the limbs* excites our admiration at the wonderful mechanism displayed in their formation: osseous portions also present themselves, which may be regarded as principally subservient in keeping up that vast chain of continuity and similarity observable throughout Nature's works. In the following explanation we shall have occasion to notice several of these.

6314. *The scápula or shoulder blade* (*k, l*), is a broad, flat, and rather triangular bone. It is very unlike the human scapula, having neither acromion, coracoid, nor recurrent process: neither is its situation at all similar to the human blade bone applied to the back; for, in this instance, the horse may be said to

have no proper back, but to be made up of sides and chest. In man, the scápula is in a direct angle with the humerus, but in the horse it does not pass out of the plane of the arm. Its superior surface is furnished with a considerable cartilage (*l, m*), by means of which its surface is augmented without weight. The posterior surface ends in a superficial cavity called glenoid, which receives the head of the humerus or arm bone. It is divided in its upper surface by its spine. The shoulder blade, as has been already shown in the exterior conformation, has neither bony nor ligamentous union, but is held in its situation by very powerful muscles, as the serratus major, pectoralis, and others. Its usual situation is to a plane perpendicular to the horizon, at an angle of thirty degrees; and it has a motion in its greatest extent of twenty degrees: hence, as it does not pass beyond the perpendicular backwards, so the more oblique its natural situation, the more extensive are its motions.

6315. *The humerus or arm bone (m)* is so concealed by muscles as to be overlooked by a cursory observer, and hence the radius or next bone is popularly called the arm. It extends from what is called the point of the shoulder, but which, in fact, is a protuberance of its own to the elbow, forming an angle with the scápula, and extending obliquely backwards as that does forwards. Near its upper extremity it sends off a very powerful head to articulate with the shoulder blade. The motions of the humerus are necessarily confined to a removal from its inclined point backward to the perpendicular line of the body. When this bone is too long, it carries the fore legs too much under the animal, and if this defect is joined to a shallow upright shoulder, the evil will be increased. It, however, fortunately happens that both the angle and extent of these two parts are usually regulated by each other.

6316. *The fore-arm (n n, o o)* is composed of the radius (*o o*), and an appendage united to it, which, in man and some animals, forms the ulna (*n n*), but which, as the leg of the horse requires no rotatory motion, was unnecessary in him. Here, however, to keep the link of resemblance in all her children of the higher order, Nature has stretched out a large process; which in the colt is really distinct, and may then deserve the name of ulna; and in the adult horse unites with the radius, and serves as an attachment to muscles. On the slightest inspection of the skeleton, it will appear how much the motions of the fore leg must depend on the length and obliquity of this process; which, acting on the principle of a lever in the extension of the arm, must necessarily, as it is either long or short, make all the difference between a long and a short purchase. The breadth of the arm, as it is called, at this part, will, from this reasoning, be seen to be very important. This bone articulates with the knee by its inferior portion.

6317. *The carpus, or wrist, called the knee (p p)*, is composed of seven bones, whose principal uses appear to be to extend the surface of attachment of ligaments and tendons, and by their interruptions to lessen the shocks of progression. It may be remarked that all hoofed quadrupeds have the anterior extremities permanently in the state of pronation, or with what is called the back of the wrist turned outwards. The carpal bones articulate with each other, and have one investing capsular ligament, by which means the smallest wound of the knee which penetrates this ligament has the effect of opening the whole joint: hence the quantity of synovia or joint oil which escapes in these cases, and hence also the dangerous consequences which ensue.

6318. *The metacarpus (q q, r r)*, canon, or shank, is formed of one large metacarpal bone (*q*), and two small ones (*r*). Here the wide palm of the human, and the paw of the digitated animal, is formed into one solid cylindrical bone, and two small additamenta, called splint bones; which are united with it by strong ligamentary attachment, converted by age into a bony one. Although these additions may somewhat increase the surface of attachment, their principal use appears to be to keep up the connection with the digits, of which they appear the rudiments. In the cow there are no splint bones, but the uniformity is more perfectly kept up by the divided hoof: in her, therefore, the canon branches at its inferior surface into condyles for the reception of the two claws.

6319. *The pastern (t t)*. The rest of the extremity below the canon, consists of one phalange only, comprising all the mechanism, and a double portion of complexity of all the phalanges of the digitated tribes. Four bones enter into its composition with two small sesamoids (*s s*) to each fetlock; placed there not only to act as a spring and prevent concussion, but to throw the tendon of the foot which runs over them farther from the centre of motion. The pastern bone is situated obliquely forward, and on this obliquity depends the ease and elasticity of the motion of the animal: nevertheless, when it is too long, it requires great efforts in the tendons and ligaments to preserve it in its situation; and thus long-jointed horses must be more subject to fatigue and to strains than others.

6320. *The lesser pastern or coronary bone (t, v)* receives the great pastern, and below expands into a considerable surface articulating with the coffin and navicular bones.

6321. *The coffin bone (v v)* forms the third phalange, and corresponds in shape with the hoof. It is very porous, and laterally receives two prominent cartilages. It is around the outer surface of this bone that the sensible laminae are attached; and the inferior surface receives the flexor tendon.

6322. *The navicular nut, or shuttle bone*, is situated at the posterior part of the coffin, and unites with that and the preceding bone.

6323. *The posterior extremities differ much from the anterior, not only in their superior strength, and in the different lengths and directions of the parts, but also, in some degree, in their uses.*

6324. *The femur, or thigh bone (3, 4)* is the largest of the body, its vast indentations and risings, almost peculiar to it, show the great strength of the muscles inserted into it. It articulates with the acetabulum or hip joint by a strong head called the whirl-bone. In this situation it is held not only by a powerful capsular ligament, and still more powerful muscles, but by an admirable contrivance resulting from a ligamentous rope, which springs immediately from the middle of its head, and is firmly fixed within the socket of the joint. In its natural situation it is not perpendicular as the human femur, but inclines to an angle of about forty-five degrees. This bone presents large protuberances for the attachment of very powerful muscles called trochanters. Throughout it exhibits a mechanism uniting the combined qualities of celerity and strength unknown to other animals. The inferior end of this bone is received by its condyles into depressions of the tibia, while the patella, or knee-pan, slides over the anterior portions of both bones.

6325. *The patella (5)*, which is by farriers called the stifle, is nearly angular, and serves for the insertion of some of the strongest muscles of the thigh, which are then continued down to the leg. It thus appears to act as a pulley.

6326. *The tibia or leg bone (6, 6)* is usually, in horsemen's language, called the thigh. It is a bone formed of a large epiphysis, with a small attached part called the fibula (7), a long body, and an irregular inferior end, adapted to the peculiarities in shape of the principal bones of the back, with which it articulates. The obliquity in the situation of this bone corresponds with that of the femur, being as oblique backwards as the former is forwards. The length of the tibia is a prominent character in all animals of quick progression; in this respect it corresponds with the fore-arm, and the remarks made on that apply, with even more force, to this — that length is advantageous to the celerity, but less so to the ease, of the motion.

6327. *The fibula (7, 7)* forms a prominent instance, in common with the splint bones, of what was remarked in the outset of our osteological detail of the extremities — that many parts, whose uses were not apparent, would be found to be organs of harmony, placed in the body to prevent interruption to the completing the general plan of animal organisation. In this way the fibula appears but a process springing from the posterior part of the tibia, forming but the rudiments of the human bone of that name.

In the ox it is wanting; in the dog and cat, as requiring numerous motions in their limbs, it is, on the contrary, perfect.

6328. *The t rsus, or hock of the horse* (10, 10), is a striking instance of the perfect mechanism displayed in the bony structure of this admired animal. It is formed by an assemblage of six bones, and sometimes of seven; while in the ox, sheep, and deer, there are seldom more than five. Between these bones there is little motion, yet there is sufficient to give a spring to the parts, and to preserve the joints from the effects of shocks, &c. As the human anatomy is generally received as the standard of comparison, we must, in order to a proper consideration of the hock, consider it as the instep and heel; and all the parts beyond it as the foot. The human t rsus, and that of some beasts, as the monkey and some varieties of the bear, makes a right angle with the tibia in standing or walking; but, in the horse, the hock makes an open angle with the tibia, and is far removed from the ground. In him, and the greater number of quadrupeds, all the bones, from the hock downwards, are much elongated, and form a part of the upright pillar of the limb. In the horse, therefore, the point of the hock is the true point of the heel, and, as in the human figure, the great twisted tendons of the gastrocn mii muscles are inserted into it: but the appellation of t ndo Achilles would be too forced here. A broad hock, as already observed in the exterior conformation, may be now still more plainly seen to be very important to strength and speed; for the longer the calc neum or heel bone of the hock, the longer must be the lever that the muscles of the thigh act by; and a very slight increase or diminution in its length must make a very great difference in the power of the joint. It is by this tendon acting on this mechanism, that, when the animal has inclined the angle between the canon and the tibia, or, in other words, when the extremities are bent under him in the gallop or trot, he is enabled to open it again. The bones of the hock, like those of the knee, are united together by strong ligamentous fibres; and it is to an inflammation of those uniting the calc neum and cuboid bones, that the disease called *curb* is to be attributed; and to a similar inflammatory affection of the ligaments in the front of the hocks, that *spavins* of the first stage are owing: in the latter stages the periosteum and bones themselves become affected. The remainder of the bones below do not differ so essentially from the corresponding bones in the fore extremities as to need an individual description. It may, however, be remarked, that the hinder canon or shank bone is longer than the fore, and that the pastern is also the same, but is less oblique in its situation; by which wise provision the horse is enabled to elevate and sustain his body entirely on his hinder parts without danger; which would not have been the case if the obliquity of those parts had been considerable.

SUBSECT. 4. *General Functions of the Bony Skeleton.*

6329. *The skeleton of the horse* must be considered as a mechanism of admirable wisdom and contrivance, which having considered in detail, we offer the following summary of its functions generally as a whole. It will be found to present nearly a quadrilateral figure, having an inclined cylinder resting on four supporting pillars. The spinal column, as the inclined cylinder, serves as a base for the soft parts, and is found not truly horizontal, but dipping downwards over the fore legs; by which the propelling force of the hinder extremities is relieved by the maximum of strength thus transferred. The increased weight of the hinder part of the cylinder is admirably counterpoised by the head and neck, which are projected forwards; by these means leaving the line of direction near the centre of the whole. The length of a cylinder may be such as not to support its own weight; Nature, therefore, has limited the length of the spines of animals: hence, *ceteribus paribus*, a long-backed horse must be weaker than a short one; and thus, likewise, small horses can carry proportionably more than larger ones. The four pillars which support this cylinder are not perpendicular partially; but they are so totally: for a perpendicular drawn from their common centre of gravity will be found to fall nearly in their common base, by which means they are supported as firmly as though their individual axes had been in a line perpendicular to the horizon. Had they been perpendicularly opposed to each other, there could have been but little elasticity, and consequent ease in motion; every exertion would have proved a jar, and every increased effort would have produced luxation or fracture. To increase our admiration of this mechanism, we need only turn our attention to the contra-disposition of these angles in the fore and hinder supporting pillars. Had these angles presented themselves in the same direction, the body must have been precipitated forward or backward; but each offering a counteraction to the other, the body is firmly sustained within them.

6330. *The bony masses are operated on by muscles*, for this deviation from a perpendicular direction in the various bony portions of the limbs must necessarily have powers to correct it, which is effected by the muscles; and wherever the angles are found most extensive, the muscles will be found proportionally strong and large. This muscular exertion, to counterbalance the angular inclination, occasions fatigue; as the set of muscles immediately employed becoming weary, the animal is obliged to call another set into action, which change is necessarily more or less frequent as the animal is weaker or stronger.

6331. *The extent of the action of the bony portions of the extremities* is the produce of the length and direction of the various parts entering their composition, and of the different angles they are capable of forming; as progression itself is effected by these angles closing, and suddenly extending themselves again. The force of the action arises from the direction of the component parts of the ankles, in combination with the agency of the muscles. The repetition of the action is dependent on the muscles alone; but as the original action arose out of the length and direction of the parts, so it will be evident that in every subsequent repetition, it will be more or less extensive, as these are more or less perfect in their formation, even though the muscular exertions should be the same; thus, some strong animals cannot move so fast as others with less strength, as the cart-horse and racer, or greyhound and mastiff.

6332. *The bony mechanism of the fore and hinder extremities presents some differences.* That of the fore limb may be said to exhibit altogether a different character. The fore-leg bones are much less angular, and appear framed purposely to receive the weight imposed on them by the impulse of the hinder limbs. This weight they are destined to sustain, until the elevation is forced on them by the tendency the general inclined mass has to meet the ground, or to find its common centre in the earth. The fore extremities, under this view of the matter, could not have been placed with equal wisdom in any other situation, nor have taken any other form. The hinder extremities having less weight on them, and at no time bearing an increase of pressure, as the fore do by the impetus communicated from behind, are much more angular; and their angles, by being thrown into a backward direction, afford the necessary impetus for the projection of the body forward. This important operation of impelling the mass being almost wholly dependent on the hind extremities, as that of sustaining it is principally confined to the fore extremities; so the former are also much stronger in point of muscular apparatus; by which their angles can be advantageously opened and closed with superior effect in progression.

SECT. IV. *Anatomy and Physiology of the soft Parts.*

6333. *We shall include under appendages to bone*, the muscles and tendons, blood-vessels, absorbents, nerves and glands, integuments, head, ear, eye, nose, mouth, neck, chest, abdomen, organs of generation, and the foot.

SUBSECT. I. *Appendages to Bone, the Muscles, and Tendons.*

6334. *The appendages to bone* are cartilages or gristle, periosteum, medulla or marrow, ligaments, and synovia or joint oil.

6335. *Cartilages* are of three kinds, *articular* (1887.), which cover the ends of the bones by a thin layer, enabling them to slide easily on one another; *non-articular*, or such as are placed between bones immovably joined; *unattached*, as those of the ears and larynx; and *temporary*, as the ends of bones in very young animals before their earthy deposit is completed. The general nature of cartilage is smooth, white, solid, elastic, and hard.

6336. *The periosteum* is a general uniting membrane to bones and their appendages (1882.); on the skull it is called *pericranium*; when it covers ligaments, *peridæsmium*; and *perichondrium*, when it invests cartilage. Its uses appear to be to furnish vessels to the bones. It is little sensible, except under inflammation, when it becomes highly so.

6337. *Medulla*, or marrow, is a soft fatty substance deposited in the cavities of bones.

6338. *Ligaments* (1891.) are close, compact, fibrous substances, of immense strength in the horse, necessary to bones as a connecting medium; ligament is also a common membrane in every part of the body. Ligament is considered inelastic; there are, however, many exceptions, of which the cervical and metacarpal and metatarsal are instances. In some cases they are semicartilaginous. The *suspensory* ligaments attach and suspend parts, as that of the thigh bone to its socket, &c. *Capsular* ligaments surround the two opposed ends of jointed bones, and form a complete cavity.

6339. *The synovia* or joint oil, being secreted from the inner surface of the capsular ligaments, fills up this cavity, and affords a slippery medium, which enables the bones to slide readily over each other.

6340. *Muscle* is that part of the body of the horse which we term flesh, to distinguish it from skin, gristle, bone, ligament, &c. Muscles appear composed of bundles of reddish fibres, the ultimate division of which it is impossible to trace; and as the motions of an animal are very various, and as almost all motion is operated through the agency of the muscles; so the peculiar shape they take on is very varied. To the generality of muscles, particularly to those ending in bones, is added a portion of a very different nature, called *tendon*.

6341. *Tendons* are insensible, inelastic, tough, fibrous substances, of a whitish colour: expanded into thin layers, they are called *aponeuroses*. The tendons are eminently useful to muscles, diminishing their size without decreasing their strength. What would have become of the light elegant limb, had the large muscular masses been continued to their terminations below in equal dimensions? Muscles are highly vascular, as their colour testifies; but the tendons are very little so, hence their powers of life are very different: one can regenerate itself with ease, the other with extreme difficulty. The muscles also possess a large share of nerves, and consequently of sensibility and irritability, to which properties the surprising phenomena they exhibit must be attributed; while their extreme vascularity furnishes them with powers to keep the energies requisite for these agencies. They contract and shorten at pleasure, acquire a power of acting dependent on their situation, and can change the fixed for the movable point, and *vice versâ*.

6342. *Muscles are voluntary and involuntary*. The former are immediately under the influence of the will, as those of the legs, eyes, mouth, &c. Involuntary muscles are such as are not under the guidance of the will, and whose functions go on without control, as the heart, the respiratory and digestive muscular organs. Muscles are many of them covered by a cellular or membranous covering, called *fascia*, and their tendons by another, but stronger investure, called *théca* or *sheath*. At the tendinous extremity there is usually a *capsule* containing a quantity of lubricating mucus, the diseased increase of which forms what is termed *windgall*.

SUBJECT. 2. *Blood-vessels of the Horse.*

6343. *The arteries are long membranous canals*, composed of three strata, which are called *tunicæ* or *coats*, as, an external elastic, a middle muscular, and an internal cuticular. Each of these coats is the cause of some important phenomena, as well in disease as in health. The *elastic* power enables them to admit a larger quantity of blood at one time than another, and thus they are *turgid* under inflammation: by this also they can adapt themselves to a smaller quantity than usual; otherwise a small hæmorrhage would prove fatal. The muscular tunic appears to exist in much greater proportion in the horse than in man, and this accounts for his greater tendency to inflammation, and also why inflammatory affections run to their terminations so much sooner in the horse than in man. The arteries gradually decrease in their diameter as they proceed from the heart. Our knowledge of the terminations of these vessels is very confined; we know they terminate by anastomosis, or by one branch uniting with another. They terminate in veins, and they terminate on secreting surfaces, in which case their contents become changed, and the secretion appears under a totally different form. Another common termination of the arteries is by exhalant openings, by which sweat is produced. The use of the arteries is evidently to convey blood from the heart to different parts of the body, and according to the part the artery proceeds from, or proceeds to, so does it receive an appropriate name.

6344. *The aorta* is the principal member of this system. Originating from the left ventricle of the heart it soon divides into two branches, one of which, the *anterior*, or *aorta ascendens* (*fig. 833. p*), proceeds forward to be divided into two principal divisions: the *carotids* (*q*), by which the head is furnished, and the *axillaries*, by which the fore limbs receive their blood, under the names of humeral, radial, and metacarpal arteries; and the *posterior*, or *aorta descendens* (*o*), which is distributed to the trunk and hinder extremities.

6345. *The pulmonary artery* is a trunk of five or six inches in length; arising out of the anterior ventricle of the heart, and continued by the side of the aorta. It soon divides and enters the lungs, through which it ramifies.

6346. *The veins* are also membranous canals which begin where the arteries end, and return that blood which has been distributed by their means. They have less solidity, and possess two tunics or coats only. They usually accompany the arteries in their course, but are more numerous, being wisely divided into a superficial and a deep-seated set, to avoid the dangerous effects of interruption. To prevent the return of the blood they are furnished with valves also.

6347. *The original venal trunks of the horse* are ten in number; the anterior cava, the posterior cava, and eight pulmonary, to which may be added the vena porta.

6348. *The vena cava* passes out of the heart by two trunks from separate parts of the right auricle. The *anterior*, or *cava ascendens* (*fig. 833. n*), opposite to the first rib, divides into four principal trunks; two axillaries, and two jugulars, (*fig. 833. r*). The axillaries furnish the fore limbs under the names of the humeral, the ulnar, and the metacarpals. The *jugulars* (*r*) run up one on each side of the trachea to return the blood of the head. The *posterior*, or *cava descendens* (*o*), returns the blood from the body and hinder extremities.

6349. *The vena porta* is formed from the veins returning the blood from the viscera, which, uniting to enter a sac of that viscus, are ramified through all parts of the liver, where the blood having undergone some remarkable alterations is returned by the vena hepatica, and enters the heart by the posterior cava.

6350. *The blood is a homogeneous fluid*, contained in the heart, arteries, and veins, and constantly circulating through the whole body. It appears formed with the body; is red in the arteries, and purple in the veins. The component parts of the blood are the crûor or coagulum; the coagulable lymph, fibrin, or gluten; and the sèrum. The coagulum is composed of red globules, whose intensity of colour is less in the horse than in man. A red colour is not necessary to the essential properties of blood, seeing the blood of some animals is white; and even some parts of the horse's body are furnished with colourless blood, as the transparent part of the eye, &c. The coagulable lymph or fibrin (1941.) appears the most essential part of the blood, and that from which all the parts are formed. The sèrum seems to dilute the whole. The quantity contained in the body is uncertain: young animals possess more than older, and hence bear bodily injuries better. It is less in quantity in fat than in lean animals; and in

domesticated than in those which run wild. An animal will lose one fifteenth before he dies. A horse lost forty-four pounds without apparent injury. Probably the quantity contained in the body may vary according to circumstances: between one eighth and one tenth of the whole mass is a fair medium.

6351. *The pulse.* From the contraction of the heart and consequent dilatation of the arteries to receive the blood, and pass it onward to all parts of the body, which is called the *diastole*; so a dilatation of the heart and contraction of the arteries necessarily occurs, which is called the *systole*; and these two causes operating alternately produce the phenomena of circulation. The momentary increase in capacity in the diameter of the artery is called the *pulse*. As there is seldom disease present, without some alteration in the circulation also, so the pulse is attended to as an indication of health or disease. The circulation being carried on over the whole body, the pulse may be felt universally; but some situations are more favourable than others; as the heart itself, the pasterns, at the root of the ear, &c.: but the most convenient of all is at the branch of the posterior jaw, where the maxillary artery may be readily detected (*fig.* 833. *t*). The natural pulse in the horse is about 45 beats in a minute; in the ox the same; in man 75; in the dog 90. When the pulse is much accelerated, the circulation is accelerated also. If, with its quickness, fulness of vessels and hardness are apparent, the circulation is *morbidly* hurried, and inflammation general or partial is present.

SUBJECT. 3. *Absorbents of the Horse.*

6352. *The absorbent system* is a very extraordinary and a very important one; for if the blood builds up and repairs parts, the absorbents pull down, remove, and take them away again. They are composed of the *lymphatics* and *lacteals*. Both kinds, although thin and transparent, are strong, and appear to have a contractile power: where very minute they are called *capillaries*. The lacteal absorbents are situated in the mesentery and intestines, whence they draw the chyle, or nutritious fluid by which the blood is nourished and augmented. The chyle is carried forward from the mesentery into a tube called the *thoracic duct*, which, passing up by the side of the aorta, pours its contents into the heart through the medium of the jugular vein. The *lymphatic absorbents* differ from the latter only in being situated over the whole body, and being the recipients of the various matters of the body; whereas the lacteals appear to absorb the chyle only. From numerous facts, we know that the various organs are continually suffering a destruction and a removal of parts, and that what the absorbents take away, the arteries renew; and to this constant change, most of the alterations of the body are to be attributed with regard to the structure of parts. We use our power over these vessels in the horse medicinally. We stimulate the absorbents to take up diseased solutions of fluids from various parts of the body, as in watery swellings in the legs by mercury and by friction, or by pressure in the way of bandage. When deposits are made of hard matter, or ligament or bone, we stimulate them by blistering or by firing. It is by stimulating the absorbents that splints and spavins are removed. Exercise is a very powerful stimulus to absorbents; thus it is that swelled legs are removed by half an hour's exercise. In the horse, the lymphatics are more liable to disease than the lacteals, but in man the reverse. Farcy diseases the lymphatics irreparably.

SUBJECT. 4. *Nerves and Glands of the Horse.*

6353. *The nervous system of the horse* is composed of white medullary cords, springing from the brain and spinal marrow, whence they are generally distinguished into the cerebral and spinal nerves: the internal structure of these bodies is fibrous, and their ramifications extend to every part of the body; it is supposed that the brain is the seat of sensation and volition, and that the nerves are only the messengers of it. The sensibility of a part is usually proportioned to the number and size of its nerves; nervous influence occasions motion. From some cause, unknown to us, some motions are voluntary, and some involuntary; but both are brought about by nervous agency. As the nerves are the media of sensation; so a division of their cords has lately been attempted, with success, to relieve certain painful affections; the most prominent instance is, in the division of the pastern nerves for the relief of the painful affection of founder. Tetanus, or locked jaw, which seems a morbid irritation on the nerves, has been recommended to be treated in the same way.

6354. *The cerebral nerves*, arising in pairs immediately from the brain, are the olfactory, optic, motores oculi, pathetici, trigemini, abducentis, auditory, lingual, par vagum, and the pair called the intercostal or great sympathetic, from its extensive connection.

6355. *The spinal nerves* are those which arise immediately from the spinal marrow, as the cervicals, humerals, ulnar, metacarpal, and pastern nerves; the dorsal, the lumbar, crural, sciatic, popliteal, sacral, and the nerves to the posterior extremities, which correspond with those of the anterior.

6356. *The glands* are numerous, and placed in every part of the body; they may be characterised as secretory bodies, composed of all the different vessels enclosed in a membrane; their office appears to be to secrete or form some fluid, as the liver secretes bile, and the kidney urine. They are classed into folliculose, globate, glomerate, and conglomerate; they also receive specific names according to their situations, or according to the fluid they secrete, as lachrymal, salivary, &c.

SUBJECT. 5. *Integuments of the Horse's Body.*

6357. *The common integuments* may be considered as the hair, the cuticle, the epidermis, or insensible or outer skin, the rete mucosum, which is immediately under this, the cutis, sensible or true skin, the cellular membranes, which contain fat and other fluids, and the panniculus carnosus or fleshy pannicle; to these may be added, the unguis, nails or hoofs, which we shall describe separately.

6358. *Hair* is the clothing of brutes, and hence is very important to them, and as it enters largely into the arts, it is also important to us. (1851.) It appears to be a production of the true skin, arising from a bulbous end, which penetrates the rete and cuticle in the form of an elongated cone. In some parts hairs appear singly, as about the muzzle; in others in masses, as on the mane, tail, and over the body generally, as an inclined congregated mass; hair varies in colour, and therefore appears by nature intended both for ornament and use.

6359. *The cuticle is situated immediately under the hair* (1845.), and appears a hard insensible covering, purposely placed to guard or defend the sensible skin underneath. The cuticle lines many of the large openings of the body, as the mouth, whence it is continued into the stomach, lining one half of it. It is perforated by innumerable small vessels that give out and take in various matters; through these blisters act on the true skin, inflame it, and force it to secrete a quantity of fluid, which thus pushes the cuticle from the cutis. It exists before birth, and is speedily renewed after birth, when accidentally destroyed, and, like the true skin, thickens by pressure; it is constantly undergoing changes; it exfoliates in the form of powder, or little scales, over every part of the body, and is that substance called dandruff, which grooms are so careful to remove with the currycomb.

6360. *The rete mucosum* is a mucilaginous substance placed like a net between layers of cuticle and cutis; and although very universal in animated nature, its use is unknown.

6361. *The cutis, corium, or true skin.* (1847.) This very general investiture of the body is situated immediately under the two former; it is very vascular, and is furnished with innumerable small villous processes of exquisite sensibility, and which, without doubt, were intended to constitute it as the real organ of touch. It is much thickened by pressure; asses, from the beatings they are subjected to, have it of immense thickness on the rump. It naturally also exists in various degrees of density according to the wants of the animal. Like the cuticle it is perforated by numerous openings which correspond with those of the latter membrane. Its composition appears principally gelatine, and hence it is employed in the manufacture of glue; its gelatine uniting with the matter called tannin, becomes insoluble

in water, and then forms leather; and the value of the horse's hide in this particular is sufficiently known.

6362. *Adipose membrane and fat.* These form very considerable parts of the body of most animals. The adipose membrane is not so universal as the skin; some parts are completely without it, as the eyelids, ears, sheath, and some portions of the extremities. It is cellular, but the cells fortunately do not communicate or the fat would gravitate. The fat is the unctuous juice poured or rather secreted into these cells. It appears in greater quantities in some parts than in others, and in different degrees of consistence; in the belly of some it is lard, and suet in others; within the bones it is oleaginous in all. Different quadrupeds have their fat of different degrees of consistence, from the firm suet of the ox, and the tallow of the sheep, to the soft lard of the hog, and the intermediate state of the horse; it guards the parts, it preserves warmth; but above all, it is a depôt against occasional want: thus a fat animal can sustain itself without food much longer than a lean one. The torpid bear comes from his hibernation emaciated, because his constitution has been subsisting on his fat.

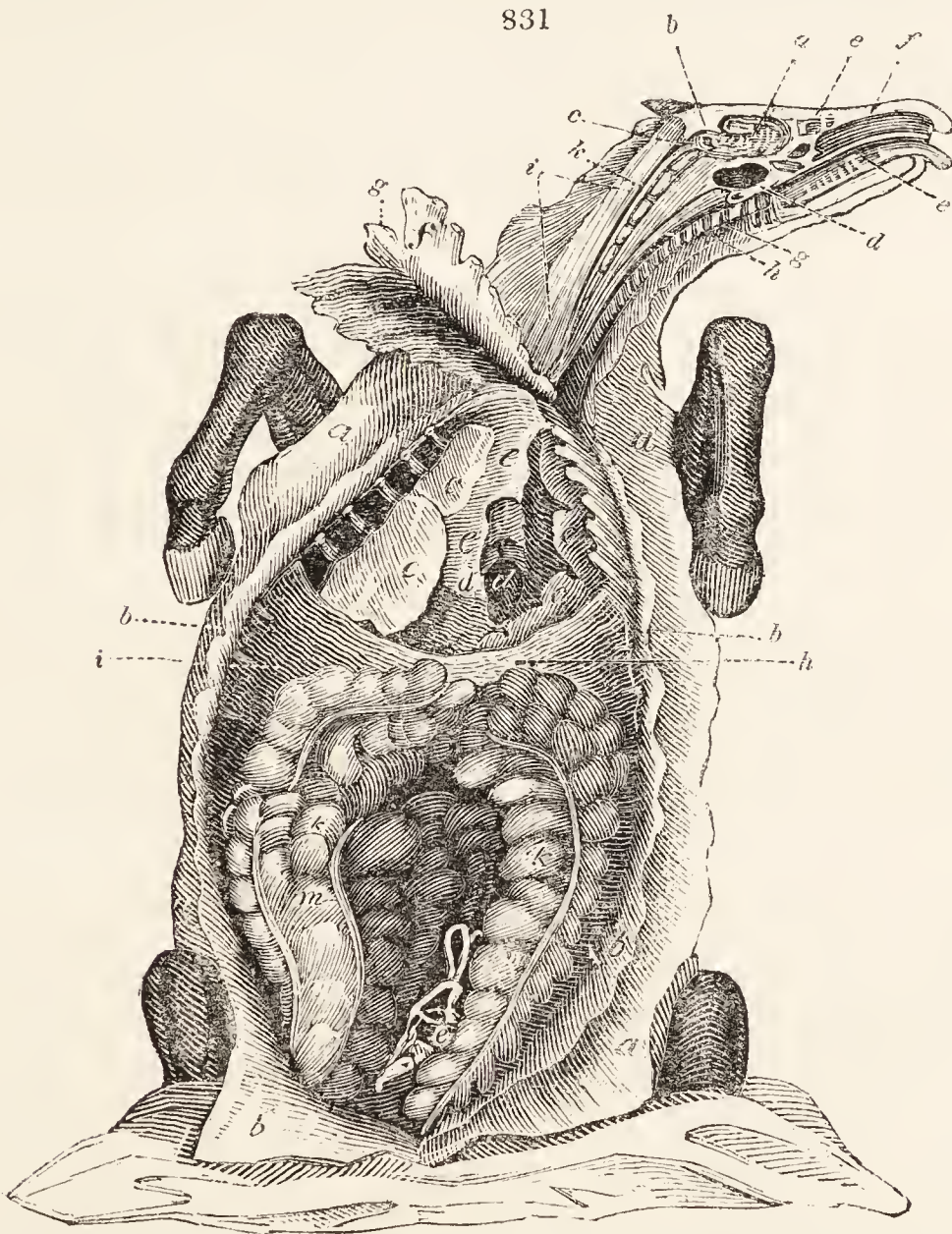
6363. *Cellular membrane.* (1849.) This complete investiture of the body enters every part, and is formed of communicating cells; as we see by the practice of butchers who blow up their meat; and also by the emphysematous effects of a fractured rib, and the gaseous distention in some putrid diseases. It exists in different quantities, and under various modifications of density throughout the body, and is a very universal medium of connection in the form of ligament.

6364. *Panniculus carnosus.* (1848.) The fleshy pannicle was kindly given to quadrupeds in lieu of hands, to enable them to corrugate or pucker the skin, and thus to shake off dust and insects. It is a thin muscular expansion peculiar to brutes, but not to all; the swine family being denied it. By its attachments it can operate variously, as we see by the uses the horse makes of it. It is very vascular and sensible, also, from the numerous nerves which enter it.

SUBJECT. 6. *The Head generally.*

6365. *The parts of the head* are external and internal; some of these have been touched on, as the integuments, &c.: such as have not will follow in the order of their magnitude or situation.

6366. *The brain of the horse* (fig. 831. *a, b, c*), contained within the hollow of the skull, is so similar to



that of man, that to describe the one is to portray the other. Like the human, it is composed of cerebrum (*a*), cerebellum (*b*), and medulla oblongata (*c*). The medulla spinalis is a direct continuation of the brain in the form of a medullary cord, called the pith or spinal marrow (*k*), which passes out of the skull through the occipital foramen. The brain appears to be the organ of consciousness, and the nerves which arise out of the medullary cord are the messengers by which sensation and volition are distributed to the various parts of the body.

SUBJECT. 7. *The Ear.*

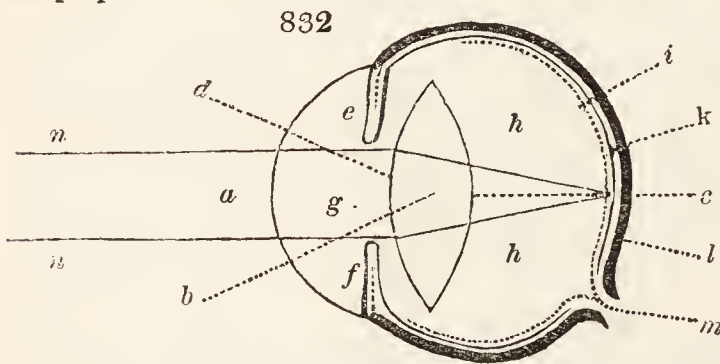
6367. *The ears of the horse* are composed of inner and outer parts. The internal parts do not differ from those of the human, but the outer are adapted to his situation and habits. These exterior parts are composed of the skin, the outer hair, the cartilages, and the muscles by which they are moved. The skin within the ears is furnished with sebaceous glands, which secrete a bitter matter, noxious to insects: and further to guard against these, it is filled with hair; which the false taste of grooms induces them to remove, and thus to expose the animal to dust, hail, rain, and insects.

6368. *The form of the ear is dependent on the concha cartilage*, which is found pointed and small in the Arabian, but large and broad in the heavy breeds. The cavity within the concha is thrown into folds throughout, which increases its surface, and reflects the sonorous waves. This outer ear is attached to the internal, by connecting cartilaginous portions and appropriate ligaments. The parts of the internal ear are, the meatus auditorius internus, or passage; the membrana tympani, or separating membrane between the external and internal parts; the tympanum, drum, or barrel of the ear; and the labyrinth. The *Eustachian tube* is an opening at the upper and anterior edge of the hollow of the tympanum, forming a duct which is in part bony, and in part cartilaginous; extending from the tympanum to a large and peculiar cavity at the posterior part of the nasal fossa.

6369. *The sense of hearing* is formed through the medium of the expansion of the soft portion of the auditory nerve over the internal ear; sounds, therefore, entering the cavity of the concha, are reflected alternately from its sides into the tympanum, whose oscillations are imparted to the brain.

SUBJECT. 8. *The Eye and its Appendages.*

6370. *The appendages to the eye* are, first, a funnel-shaped cavity formed by the concurrence of the bones of the skull, called the *orbit*, not placed directly in front as in man, but inclining laterally, to enable the animal to embrace a larger field of view. The *eyelids* are an upper and under, of which the upper is the most considerable, and enjoys the greatest motion. United, they form an admirable curtain to defend the eye from dust, insects, and the light during sleep; and are moved by two appropriate muscles. Attached to the edge of each is a cartilaginous rim, called the *tarsus*. The *cilia*, or eyelashes, are not, as in man, above and below; the upper lid only is furnished with hairs, and these are not placed in one row, but in several smaller rows. The horse has no supercilia or eyebrows, unless we reckon as such the few long hairs over the orbits. The *lacrimal gland* is a body lodged within the upper part of the orbit; it is furnished with five or six excretory ducts, which secrete the lachrymæ or tears to lubricate the surface of the globe. The superfluous tears are carried off by two openings at the inner angle, called *puncta lachrymalia*, by which means the tears are at once carried into the nose, and not as in man first into a lacrimal sac. The *caruncula lachrymalis* is a small black substance in view at the inner canthus, whose office appears to be to direct the tears aright in this course. The *haw*, or *nictating membrane*, is an important part, seen when the eye is drawn inwards, but which is at all other times hidden within the fatty matter surrounding the globe of the eye. Though called a membrane it is cartilaginous, and when the eye is forcibly withdrawn into the socket, it is pressed out from the inner angle, and passes completely over the surface of the globe, to which its shape is adapted. A moderate pressure only shows about half of it; and it is thus seen in tetanus or stag-evil, by the action of the retractor muscle; and under inflammation of the eye it also becomes visible, which has led ignorant farriers to cut it off, under a suspicion that it formed one cause of the disease. The use of this nictating membrane cannot be for a moment dubious. It is denied to man and to monkeys, because they, having hands, can with their fingers remove dust and dirt from the eyes; but to the horse and most other quadrupeds it is essentially necessary for these purposes.



6371. *A diagram of the eye (fig. 832.)* displays the transparent cornea in front of its globe (a), the crystalline lens (b), its posterior convexity (c), its anterior convexity (d), the iris, or curtain (e, f), the anterior chamber occupied by the aqueous humour of the pupil (g), the posterior chamber filled with the vitreous humour (h h), the retina (i), the choroid coat (k), the sclerotic coat (l), and optic nerve (m), rays of light showing the different degrees of refraction they suffer in passing through the humours of the eye (n n).

6372. *The globe of the eye* is composed of coats, chambers, and humours, and is operated on in its movements by muscles. It may be considered as forming a large cup posteriorly, with a smaller cup applied to its margin anteriorly; or as though the segment of a large sphere were adapted to that of a smaller one. The substance which gives figure and consistence to the larger segment is the *sclerotic coat* (l), which is very firm and fibrous. The anterior cup or segment is supplied by the *cornea*, which is transparent, and formed of thin concentric plates of very different degrees of convexity in different animals, and often in similar animals; to a defect in which is ascribed the indistinct vision or starting of some horses. The *cornea* (a) is vascular and sensible, and in an inflamed state it admits the red blood, as we see by the universal redness over the whole; at other times it admits only the colourless parts of that fluid. Immediately within the sclerotic coat is a thin vascular membrane, called the *choroides* (k), which is spread over it nearly as far as the cornea, where it turns in and expands into the ciliary processes. It also by a peculiar fold forms a ligament, after which it produces another projection into the cavity of the eye, termed the *uvea*. It is here continuous, and presents a veil perforated in the centre.

6373. *The pupil of the eye* (g) is the perforation which is seen annular in the human, oblong in the horse, ox, and sheep, and perpendicular in the cat. The anterior surface of the uvea is covered with a membrane, termed iris, on which the colour of the eye depends: in man it is grey, brown, black, or blue; in the horse it is usually brown, but now and then white, when the animal is said to be wall-eyed. At the central margin of the iris are seen, in a strong light, some little globular bodies or bags, covered with a black pigment. They are usually attached to the upper margin only, but when any exist on the lower they are small; they have been mistaken for disease. The *iris* (e, f) is capable of accommodating itself to circumstances; that is, it can enlarge the diameter of the central aperture or pupil (g), so as to admit or shut out the rays of light. Over the central surface of the choroid expansion is spread a dark mucous substance, called *nigrum pigmentum*. In animals, whose vision is distinct at night, this pigment is found of a lighter colour: in man it is very dark, and his crepuscular vision is, therefore, indistinct. In the grazing tribes it is of a greenish cast, lost in azure blue; in the predaceous tribes it is still lighter. Under this pigment is the mucous expansion, peculiar to quadrupeds, called *tapetum*. The *optic nerve* (m) penetrates the sclerotic coat, and becomes expanded on its inner surface, in a membranous lamina of exquisite fineness, called *retina*. On this, it is supposed, objects are painted, and thus taken cognizance of by the brain.

6374. *The humours of the eye* are the vitreous, the crystalline, and the aqueous. The vitreous humour (h h) is of a jelly-like consistence, and occupies all the globe, except those parts taken up by the other humours. The *crystalline humour* forms a lenticular body of moderate consistence, and is, therefore, more properly called a *lens* (b). It is doubly convex (c, d), its posterior side resting in a concavity of the vitreous humour. It is not of equal consistence throughout, being much firmer in the middle. Different animals have the lens of different figures, to suit the purposes of their existence: in fishes it is nearly spherical, but in quadrupeds, lenticular. It is a diseased opacity of this body that forms cataract. The *aqueous humour* is a limpid fluid which fills up the spaces not occupied by those already described.

6375. *The muscles of the eye*. The motions of the eyeball are operated by seven muscles; four recti or straight, which elevate, depress, and draw to and from; two oblique, which rotate the eye; and a retractor

or choanoid, peculiar to quadrupeds, to draw the eye within the socket and thus preserve it from danger, which draws the globe inwards.

6376. *The phenomena of vision.* If the diagram be examined, it will be evident that the eye of the horse presents an optical instrument of exquisite workmanship and mechanism, admirably fitted to collect the luminous rays from the various objects around, and to transmit them with truth to the brain. If the luminous rays reflected from objects passed through the eye in a rectilinear course, as they do through the atmosphere, no cognisance at all useful to the animal could be taken of them by the eye; all would be glare and indistinctness: but being refracted or bent by the media through which they pass, the rays finally meet at a point called their focus or focal point. Neither would one simple line of refraction have been sufficient to answer all the purposes of perfect vision, under its various modifications. It is necessary that the refraction should be increased in its passage by increased degrees of density in the media of its transit (*n n*). In the passage of the rays through the cornea and aqueous humour, they must encounter their first refraction; and it is evident, that the more convex the anterior portion of the eye may be, the more will this refraction be increased. We need not, therefore, be surprised that a goggler, or horse with this form of eye, should start. The next and largest degree of bending which the rays receive occurs in their passage through the crystalline lens, which from its lenticular form must necessarily be considerable; in their progress through the vitreous humour a farther refraction is effected, till meeting in a point on the rétina, a perfect representation of the object or objects viewed is obtained; the rays forming in their passage numerous cones, the bases of which will be the object viewed, and the apex of each a radiant point. Amidst the number of objects around, it appears that the eye has a capability of collecting rays from such only as are immediately necessary for the purposes of the animal it belongs to; hence, although the general field of view may fall under an angle of vision, yet such rays only as are immediately capable of this convergency produce effect, all others are lost in the black pigment of the eye, apparently placed there purposely to absorb the superfluous rays. As the eye must necessarily have a vast variety of objects painted on it whose distances are widely different, there must be some optical adjustment of the powers of the part to enable it to effect a distinct vision of all objects near or remote; but whether this takes place by means of the angle formed on the two opposite axes, or as has been more lately taught, by a muscular power in the lens itself, is not yet satisfactorily ascertained: certain it is that after the loss of one eye, time is required both in the human and brute subject for the remaining eye to learn to adjust itself to judge of relative distances; which fact is certainly in favour of the opinion that an angle formed between the eyes regulates the judgment of distances. In this way we can account for the well known fact, that hunters, which have before the loss of an eye been excellent and sure leapers, have afterwards lost the power of measuring their leaps. Were it not for some adjustment of the optical organ itself, the rays reflected from objects very near the eye would fall behind it, and those from distant ones would, from being almost parallel, meet together before the rétina. The mechanical adjustment of the focus is also assisted in some measure by the iris, which contracts almost to a point when we look at a very minute object; and by this means only permits such rays to pass through as penetrate the centre of the lens, by which such rays will be very much refracted; but when the eye regards distant objects, the iris becomes dilated, and the rays are then viewed through the edges of the lens, and their inclination is thereby lessened.

6377. *The criteria of soundness in the eyes* are gained by a careful examination of them; and which experience has shown to be best made by placing the horse within a stable, with his head nearly approaching the stable door, which should be fully open. Small eyes are found more prone to inflammation than large, and large goggling eyes are more liable to accompany a starting horse than lesser ones: and when the convexity is extreme, not only is the starting in proportion, but such eyes are more liable than others to become affected with the disease popularly called glass eyes, but medically *gutta serena*. It is not, however, to be understood that all starters have defective eyes; many are so from natural timidity, and still more from harsh usage. The eyes should be examined together, not only to observe whether each presents an equal degree of clearness in the transparent part and within the pupil, but also that an equal degree of contraction exists between each of the pupils. This is of much consequence: if any inequality in size or form be observable between the pupils, the least of them has been in some way affected, and will probably become so again. It is even more suspicious when a turbid milkiness appears on any part of the transparent portion; and equally so, when the inferior part looks other than clear; or, in a very strong light, with a lively bluish tinge. When it is at all turbid, viewed under various aspects, regard it attentively, and there may probably be found an inward speck of perfect white; which is the nucleus or central point of an incipient cataract.

6378. *A glassy greenish cast in the eye should occasion suspicion*, and the hand should be placed over such eye so as to exclude the light; remove the hand suddenly and watch the motions of the iris or curtain of the pupil. If it do not contract, carry the examination still further, and it will probably be found such eyes are totally blind. A blind horse usually carries his ears about, as though in alarm, on his leaving the stable; he also lifts his feet on such occasions, particularly in strange quarters, higher than a sound horse.

SUBJECT. 9. *The Nose and Sense of Smelling.*

6379. *The organ of smell* is, in most quadrupeds, the next in importance to that of vision, and in many points of view it is even of more consequence. With the herbivorous tribe, it forms their principal means of judging between the noxious and the innoxious. It is not therefore to be wondered at, that it should in these tribes form so large a portion of the head; nor that it should be so exquisitely gifted with sensibility, or so admirably formed to answer its important purposes. The external parts of the nasal organ are the two nostrils, and as much of their convolutions and linings as come into immediate view. Internally these two cavities are carried upwards into the pharynx, but completely divided by a cartilaginous septum (*fig. 831. f*). In this course they communicate with numerous openings and cavities, formed within the bones of the skull (6300.), the whole of which are lined by one continuous membrane of exquisite vascularity and sensibility; being largely furnished with blood-vessels, which gives them such a ready tendency to inflame and become red, as we witness under only a slight degree of exertion, and as we see more evidently when violent colds or inflammations on the chest are present. Its sensibility is derived from the olfactory nerves, which are spread over all its surface. It is this membrane which is the peculiar seat of glanders, becoming first inflamed, and next ulcerated throughout its extent; and as the membrane itself appears to be continued to the pharynx and larynx, so we need not wonder why the glanders proceeds to disease the lungs; nor why a common cold, which is at first a simple inflammation of this membrane, so readily degenerates into inflammation of the lungs. The common integuments or coverings of other parts are extended over the nose, but it is little furnished with fat. Of hairs it has a fine thin covering to the edges of the nostrils, and a longer set, which are carefully removed in trimming. By a fold of the skin, within which is a cartilage, the false nostril, as it is termed, is formed, whose use appears to be to keep open the canal for the transmission of air, and yet to offer an interruption to extraneous matter. When the nostrils are a little separated, a small canal may be seen, which is the nasal duct for the transmission of the superfluous moisture from the eyes. The horse breathes or respire wholly through his nostrils in all ordinary cases.

6380. *The sense of smelling.* The volatile particles from all odorous bodies are continually passing off from them, and consequently some must reach the olfactory organs, whose capability of taking cognizance of their qualities appears derived as before pointed out, by the expansion of nervous fibrillæ from the olfactory nerves which transmit impressions to the brain.

SUBJECT. 10. *The Cavity of the Mouth.*

6381. *The external parts of the mouth* are the lips, cheeks, and beard. The *lips* are made up of fleshy masses so disposed as to give them motion every way; they are covered over with a very fine expansion of skin almost devoid of hair, their exquisite sensibility forms them into an organ of touch; and in this point of view they may be considered as supplying the part of the points of the fingers in man. The *cheeks* are equally muscular and moveable, but are more furnished with hair; and the *beard*, in addition to this thin hairy expansion, has a set of long hairs.

6382. *The internal parts of the mouth* are the teeth already described (6260.), the gums, the alveolar edges, the palate, the tongue, and the parts of the great posterior cavity. The *gums* are a spongy substance which embraces and holds fast the teeth in their *alveolar sockets*. The membrane which covers the gums at the lower part of the channel forms a kind of fold to connect and confine the tongue on each side. These folds are called the *barbs*, and are apt to be mistaken and cut off as excrescences. The *bars* are the spaces in the jaw left between the grinders and nipper teeth; and which man, ever ready to take advantage of for his own purposes, has made use of to ensure obedience by placing on its sensitive surface the pressure of the bridle-bit. The *palate* forms a bony arch, covered by membranous folds, which are apt, when the stomach is affected, to become swollen, in which case the horse is said to have the lampas or lampers. (6446.) By means of these rugose folds, the food is retained within the mouth. The *curtain of the palate* or *vèlum palati*, which is situated at the extreme end of the palatine arch, is stretched directly across the hinder mouth, and is not intercepted as in man by the pendulous body termed *uvula*. This palate curtain is intended to shut out the communication between the mouth and the great cavity of the fauces, which it does at all times, except when the horse is swallowing, at which period the curtain is forced back and the food passes. From this cause likewise the horse is prevented from breathing but by his nostrils; and when any air does pass by the mouth, as in coughing, crib-biting, &c. it is only effected by a forcible displacement of the curtain.

6383. *The tongue is a long fleshy mass* (fig. 831. e), which adapts itself below to the form of the channel, and above to the arch of the palate: its external surface is rough by means of papillæ, which are inclined backwards, and thus resist the loss of the food received within the mouth. In some animals, as the ox, bear, &c., they are very large, and in the cat pointed. The tongue is a very principal organ in mastication, carrying, by its great mobility, the food into every direction until fully acted upon, and finally passing it into the pharynx.

6384. *Sense of tasting.* It is not observed that this sense is so diversified in brutes as in man; but it is instinctively so correct, that it seldom errs in the herbivorous tribes; and when it does, there is reason to suspect some present defect in the organ, arising from morbid sympathy, which (as in the instance of salt-water, of which at some times horses will drink immoderately,) prompts them to take in matters they are accustomed to refuse. Taste was given to brutes to regulate their other senses, and thus there are few plants or substances whose application to the tongue, under ordinary circumstances, produces an agreeable effect but such as are proper for food. Nature, therefore, stimulates her creatures to search for edibles by a double motive, the calls of hunger and the pleasures of taste; and these are usually in unison, for the nausea of repletion destroys the appetite of taste.

6385. *The pharynx.* The cavities of the mouth and nose terminate in the great cavity of the fauces called by this name, to which also is appended another lesser opening called the larynx, immediately appropriate to the entrance of the trachea or windpipe. Within this great chamber, at the afterpart of the mouth, shut from it by a membrane only, is the Eustachian cavity, into which the Eustachian tube opens, and which great membranous hollow is unknown in man and most quadrupeds (fig. 831. d.) Its use is not understood, but it is probably connected with the voice.

6386. *The larynx* is situated at the posterior part of the former cavity, and appears as a cartilaginous box between the os hyoides, to which it is attached for support. This cartilaginous box, or entrance to the windpipe, is formed of several pieces, and is furnished with a kind of movable door, which, in ordinary cases, exactly fills up the cavity left by the arch of the palate curtain, thereby shutting the cavity of the mouth, and forcing the animal to breathe through his nasal openings. In extraordinary cases, as when the animal swallows food, this cartilage is forced down, and then it becomes a door to the glottis or funnel part of the trachea, and thus prevents the entrance of extraneous matter into the lungs. All these parts are operated on by numerous muscles.

6387. *The voice.* The larynx has also another important office in being the organ of the voice. The cartilages of the larynx are very movable on one another, and are furnished with muscular cords, which tighten or relax them; besides which, they are also furnished with peculiar and appropriate sacs or cavities, independent of the tracheal opening, and which are of different magnitudes and directions in different animals. The cartilages of the larynx being acted on by the *cordæ vocales*, produce different degrees of density, and consequently different degrees of expansion in the laryngeal sacs; by which, either in expiration or inspiration, are produced different degrees of vibration, and consequent intonation. *Neighing* appears produced wholly by expiration through the nose, as are most of the tones of the horse's voice. This is proved by slitting the nasal cartilage, which wholly stops it. *Knuckering*, as it is termed, is only a lesser neigh, with shorter, deeper, and less forcible tones. The former sound is used as a call, the latter as either call or recognition. It is likewise, when used mildly, significant of joy and affection, and is then beautifully sonorous. The horse has an acute sound produced by inspiration, usually descriptive of lust: in most other cases his intonations are accompanied by expirations; nor does it appear that the tongue or teeth of the horse are much concerned in the modulations of his voice.

6388. *The parotid glands*, or, in the language of farriers, the *vives*, are two considerable bodies on each side of the head, extended from the base of the ear around the angle of the jaw. Each parotid is a conglomerate gland, furnished with numerous little ducts, which unite into one, and enter the mouth about the second molar tooth. These glands furnish saliva for the use of the mouth, and it is an induration and gathering, either in them or the maxillary glands, which form the strangles of young horses. Assistant to these in the furnishing of saliva are the *maxillary glands*, situated within the branches of the lower jaw, and the *sublingual* also.

SUBJECT. 11. *The Neck.*

6389. *The external parts of the neck* are the common coverings which have been described; the cervical ligament, the muscles, and the jugular or neck veins, &c. The *cervical ligament* (fig. 831. i), is a very strong substance, in some parts semimuscular, and in all extremely elastic, stretched from the occipital bone along the back of all the cervical *vétræ* except the first. Continued on the spinous processes of the dorsal *vétræ*, it fills up the dip or depression of the spinal column of the neck, so completely as to form the neck either into a plane, or an elegantly convex line upwards. By its extreme tenacity, the ponderous mass of the head is preserved in its situation, without the necessity of an immense mass of muscle which would, without this contrivance, have been necessary. It is to an injury received at the upper and anterior part of this ligament, that the pole evil is owing. The muscles of the neck are too numerous to allow of particularisation; it is sufficient to say, they most of them run longitudinally. The jugular veins run one on each side of the neck superficially, on the side of the trachea and windpipe, and form the vessel usually bled from (fig. 833. r). A few inches before they reach the angle of the jaw, each divides to furnish the head.

6390. *The internal parts of the neck* are the *vétræ*, within which passes the spinal marrow. The *carotid arteries* pass up under the jugular veins, near the *œsôphagus* (fig. 833. s). The *trachea* or wind-

pipe (*fig. 833. g*), is a large canal for the transmission of air, formed by alternate rings of membrane and segments of cartilage, rendering it at once flexible and cylindrically hollow. The *œsôphagus* (*figs. 831. h & 833. s*) is the continuation of the funnel-like cavity of the pharynx. It is externally muscular, and internally membranous and cuticular, by which formation it is elastic, to allow of distention in the act of swallowing. The *œsôphagus* penetrates the chest within the mediastinum, and passing along the spine (*fig. 833. l*), through an opening in the diaphragm, terminates in the stomach.

SUBSECT. 12. *The Thorax or Chest.*

6391. *The chest* of the horse is bounded anteriorly by the matters filling up the space between the two first ribs, posteriorly by the diaphragm, laterally by the ribs, above by the *vertèbræ*, and below by the sternum or breast-bone. In dissecting the horse, after the interior membranes, muscles, &c. are thrown back (*fig. 831. bb bb*), there appear the lobes of the lungs (*ccc*); the heart (*d*); mediastinum or membranous division of the chest (*ee*); the sternum or breast-bone (*f*); the ensiform cartilage (*g*); and tendinous centre of the diaphragm (*h, i*).

6392. *When the chest is opened* a smooth polished membrane is seen, which covers the surface, and then is reflected over its contents; this is called the *pleura*; and by a junction of the two *pleuræ*, a division of the chest into two nearly equal portions is effected, which membranous division is called the mediastinum. By this division of the chest into two parts, very important benefits arise; as when one cavity is opened the lungs immediately collapse, but the respiration may be carried on by the other. In a similar manner ulceration may proceed to destroy the lobes of one side of the chest, as in glands, but may be checked by the mediastinum from proceeding to the other. The *pleura* does not, as in man, appear to take on inflammation independently of the substance of the lungs; thus the horse is not subject to pleurisy. The thymus gland, which is a considerable body in the colt, and which forms the sweetbread in calves, is hardly discernible in the old horse. It is situated between the folds of the mediastinum, but its uses are unknown.

6393. *The diaphragm or midriff* (*fig. 831. i, h*) is a very important part of the body of the horse, dividing the chest from the belly by its disk, but which is far from elliptical, extending much further backwards than forwards. Its fibres radiate from their origins to unite in one tendinous centre (*h*). In a state of rest it is anteriorly convex, and posteriorly concave; but at each inspiration these appearances are nearly reversed. (6398.) It is perforated for the passage of the *vèna cava*, the *aôrta*, the *vèna ázygos*, thoracic duct, and *œsôphagus*, all which pass through it by means of three openings. It has been found ruptured in some desperate cases of broken wind.

6394. *The heart* (*fig. 831. d*) is the great agent of circulation, and is made independent of the will; were it otherwise, man and other animals might cease to live at their own discretion. The *pericárdium* is first seen surrounding the heart so completely, that it swims within it by means of a little fluid termed liquor pericárdii. The heart is a composition of membranous and muscular fibres, having four principal cavities, and several openings. It is situated within the mediastinum, so as to occupy a cavity of its own, distinct from either side of the chest. Its base is in a line with the dorsal *vertèbræ*, and its apex is directed to the left of the sternum, between the eighth and ninth ribs. Its two ventricles are immediately within its body, and its two auricles are rather without, appended to it. The left ventricle contains arterial blood, and from it originates all the arteries except the pulmonary. The right ventricle is the reservoir of the venous blood, and it receives all the veins except the pulmonary. Within the ventricles are valves to prevent the return of the blood. The auricles are less muscular than the ventricles; the left, or pulmonary, opens into the left ventricle; and the right communicates with the right ventricle. Into the right and larger auricle the anterior and posterior *cavas* enter by two openings, and into the left, the pulmonary veins pass.

6395. *The circulation of the blood* may be shortly described as originating with the left ventricle of the heart, which sends its blood, by means of the great vessel called the *aôrta*, to all parts of the body. The blood thus distributed is collected again by the veins from all parts, and is by them returned into the heart by means of the two *cavas*, which pour their contents into the right auricle, which immediately forces it into the right ventricle. From the right ventricle it is again forced out into the pulmonary artery, which carries it throughout the lungs to undergo a change, and to be finally returned by eight trunks into the left auricle, which immediately empties it into the left ventricle to renew the process described.

6396. *The lungs are spongy masses* divided into right and left, with less divisions called lobes. Their colour varies according to age: thus, in the colt they are of a light lively pink; in the full grown horse they approach to a greyer tint; and in the very old subject they are of a still deeper tone. The bronchia are continuations of the trachea or windpipe, which, dividing on its entrance into the chest, ramifies throughout the substance of the lungs, giving these masses their spongy cellular structure, in which distribution the air vessels are accompanied by ramifications of the pulmonary artery and veins. From the extreme vascularity of these parts they are very liable to inflammation.

6397. *The theory of respiration.* By some extraordinary sympathy, the colt at birth gasps, and air rushes into the lungs before collapsed: having once felt this stimulus, by a common consent between the diaphragm and intercostal muscles, the cavity of the chest is diminished to expel the air received, and to inspire a fresh quantity; and which process is then continued through life. The body appears vitally nourished by two sources: the one through the medium of digestion; the other by means of the blood itself, which, in its progress through the body, gives out its vital principles of heat to the mass, and vitality to the muscular fibre, for unless the blood effect its part in the contractile phenomena it will be in vain for nervous influence to exert its power. Having given out these principles, it is returned by the veins, and is passed forwards into the lungs, circulating throughout their substance, and imbibing, by their contiguity or continuity with the air vessels, oxygen gas from the atmospheric air contained in them. In return for the oxygen received, carbon is given out, which passes off in the form of aqueous vapour. As the blood is renovated, so the air it acted on is deteriorated, and is therefore expired from the chest to make room for a fresh inhalation, to oxygenate a fresh quantity of blood, and thus to renovate afresh the vital powers subservient to its influence.

SUBSECT. 13. *The Abdomen.*

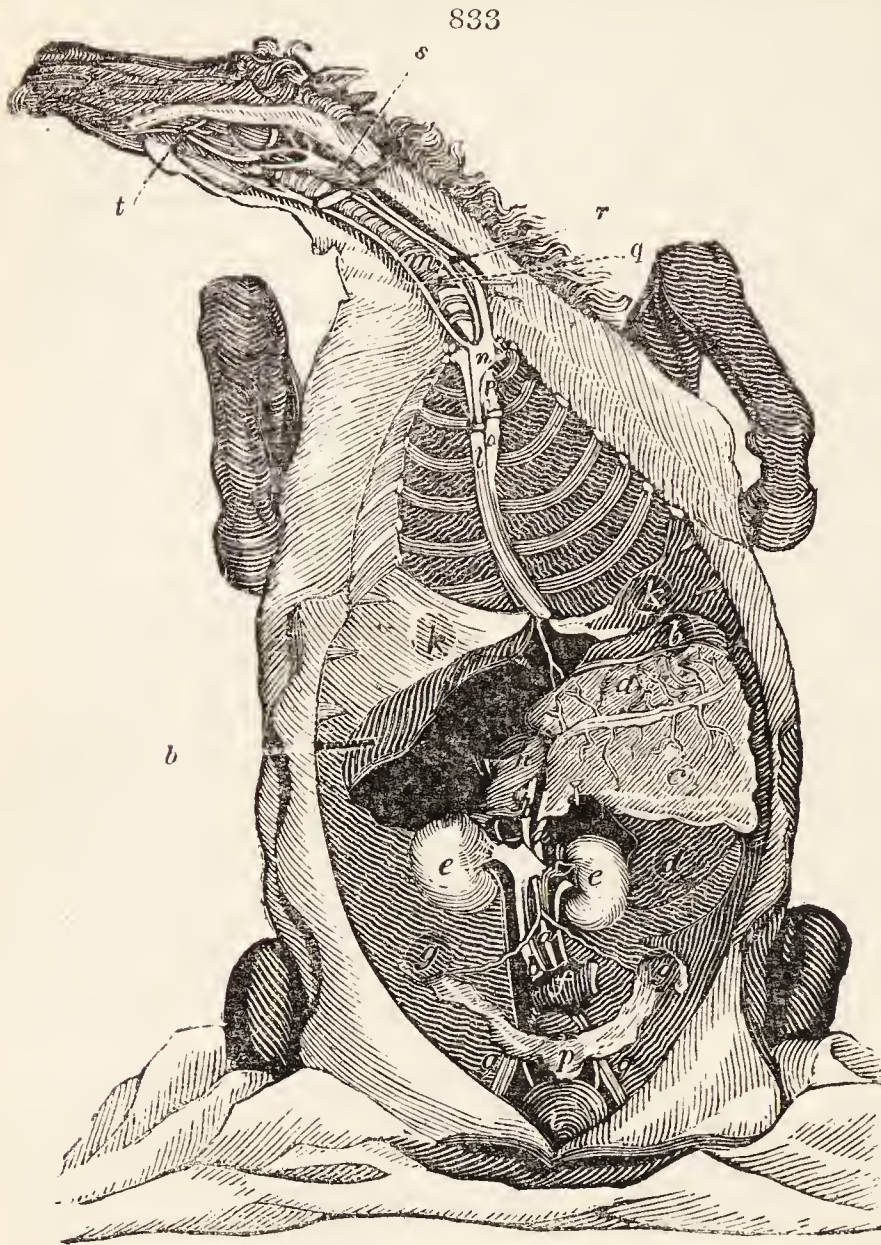
6398. *The viscera of the abdomen* include the stomach (*fig. 833. a*); lobes of the liver (*bb*); omentum or caul attached to the whole inferior curvature of the stomach (*c*); the spleen (*d*); the kidneys (*ee*); the rectum (*f*); the *ovària* (*gg*); the *ùterus* (*h*); the bladder distended with urine (*i*); the diaphragm or muscular partition dividing the belly from the chest (*kk*); *œsôphagus* or gullet proceeding to the stomach (*l*); trachea (*m*); *vèna cava ascèndens* (*n*); *aôrta descèndens* (*o*), which passes through the abdomen (*aa*), as does the *cava descèndens* (*b*); the *aôrta ascèndens* (*p*); carotid arteries (*q*); jugular veins (*r*); *œsôphagus* (*s*); and maxillary artery, forming the most convenient situation for feeling the pulse (*t*); which completes the viscera and general appearances of the horse when laid open.

6399. *The abdomen or cavity of the belly* is the largest cavity of the body, and forms an extensive oval vault, containing very important viscera, which may be considered as the chylopoietic, the urinary, and the spermatic, all which are invested by a membrane called the peritonèum, which, after covering each of these organs separately, is reflected over the cavity of the belly itself. It is very strong, and very elastic, as we perceive by the effects of dropsy, great fatness, and likewise by the increase in pregnancy. The *omentum or caul* (*c*) is the fatty apron which first presents itself on opening an animal's

body, extending in some, as the dog, pig, &c. into the pelvis; but in the horse it is less considerable, from which he is not subjected to epiplocele as they are. Its uses are unknown.

6400. *The stomach and its digestive functions.* The horse has one stomach only, and that a very small one, drawing a very wide line of separation by this means between his family and the ruminants. In fact

the stomach of the horse may be regarded as intermediate between the triturating muscular one of fowls, and the membranous one of the Graminivora. It is peculiarly constructed to keep up this intermediate character, being partly membranous, partly muscular, and partly cuticular; in which latter formation much of its peculiarity consists, and which it shares in common with asses, rats, and mice; whose habits of living on grain give them a like claim to this wise provision. In a state of rest, or only moderately distended, its direction is across the abdomen, with its two orifices directed upwards; but the cardiac or recipient orifice, to which the œsophagus is attached, the most so; while the pyloric or expellent orifice is rather lower, and more inclined backward. The situation of the stomach is immediately contiguous to the diaphragm or great breathing muscle (*fig. 833. k k*), from which we are at no loss to understand why a very full meal obstructs respiration; and why it is so imprudent to gallop a horse very hard after drinking or eating fully. Small as the stomach is in a natural state, it is yet capable of great distention, as has been witnessed in stomach staggers, when upwards of half a hundred weight of undigested food has been extracted from it. The membranous portion of the stomach is gained from the peritonæum; within this is situated its muscular part, principally composed of longitudinal and transverse layers, by which its motions in digestion are regulated. Around the cardiac

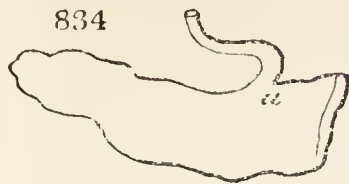


or recipient orifice, a strong band of circular fibres is very evident, which effectually constricts this part, and prevents regurgitation or vomiting in the horse, except under extraordinary circumstances of muscular relaxation and sympathy. It has been already shown that the anterior part of the alimentary canal, as the mouth, throat, and gullet, are lined with cuticle or skin. This cuticle is continued into the stomach, and lines nearly a half of its internal surface, whose office seems to be a more perfect comminution of the food, which the horse has no opportunity of remasticating like the ox, sheep, &c. The villous or sensible portion of the stomach is thrown into folds, so as greatly to increase its surface: here the comminuted food in its passage becomes saturated with the solvent *gastric* juice, and is then passed forward into the intestines.

6401. *The derangements of the stomach* may be explained from its anatomy. Though small, and its sensible parts still smaller, yet it is subject to more diseases, and to more frequent derangement, than is generally supposed. It has been proved to be muscular, and that its digestive functions are performed by means of its muscularity. It has also been shown that the contractile energy of the muscular fibre, is mainly gained from the oxygen derived from the blood; whatever tends to interrupt this separation, as an unhealthy state of the lungs, too quick action of them, &c. must derange the action of the stomach also. The perfection of its digestive powers is also derived from its secreting healthy gastric juice, consequently whatever interrupts this process must likewise interfere with stomachic health; and that such health is more often impaired than is generally supposed, and that many ailments, attributed to other causes, are really dependent on an affection of this organ, experience and observation will fully evince. Out of condition is a most frequent complaint among horsemen; their horses are out of condition, and unfit for work: the appearances are various, but are all well known; yet it is seldom considered that it is owing, in every seven cases out of ten, to the stomach being morbidly affected. (6425.) It is evident that too full feeding must derange it, not only by keeping it constantly distended, and thus weakening its capacity; but by entrenching too much on its secreting office, and requiring an inordinate quantity of gastric fluid to saturate an undue quantity of farinaceous matter. The bots, that are frequently found on its cuticular coat, and are there probably harmless, sometimes displace themselves, and settle on the villous part, where they must occasion uneasiness and probable inflammation.

6402. *The intestines* (*fig. 831. k, l*) in the horse may be considered not merely as discerning organs alone, as in man and many animals, but as really digestive organs, and continuations of the stomachic viscera. This is more particularly the case with the small intestines, and may therefore entitle them to the term of alimentary canal, and the large to that of the excremental; the former measure from twenty-one to twenty-three yards in length, and the latter from seven and a half to eight yards and a half, according to the size of the animal. The duodenum is the first of the small intestines, commencing at the pyloric orifice of the stomach; the jejunum, which is the next and larger portion, and the ilium (*fig. 831. e*), which is still longer, form the remainder. The alimentary canal in its structure does not differ from the sensible part of the stomach, having like that two plans of muscular fibres, a circular and a longitudinal, by which its peristaltic motions are regulated; the longitudinal shortening the canal, and the circular diminishing its size. The alimentary part of the intestinal canal ends with this small gut, which itself

terminates abruptly in the cæcum or first of the large intestines (*fig. 834 a*), and which intestine commences what has been termed the excrementitious canal. This entrance is effected in such a manner as to leave, by a protrusion of its surface inwards, a kind of valvular apparatus, which prevents the return of the contents.



6403. *The large intestines* (*fig. 831. k k*) in the horse are really deserving of that name, being very capacious; while in man and carnivorous animals they are little different from the small. They occupy and completely fill up the lower portion of the abdomen: the cæcum occupies the right side, and carries its blind end towards the diaphragm, which is not furnished with an appendix as in man. A careful inspection of this intestine will show that the appellation of excrementitious canal does not wholly apply to it; but that, on the contrary, it performs some of the offices attributed to the smaller intestines. The colon commences small from the side of the base of the cæcum; but soon enlarging, it makes a turn round the abdomen, when contracting it ends in the rectum, and passes backwards to the anus. Along the course of the large intestines are muscular bands, which throw their surfaces into folds, and also form them into a continuation of cells (*fig. 831. m*). By these means, the matters are detained to be acted on more fully, and finally they are expelled in dry hardened balls.

6404. *The digestive process* in the horse is one of the most curious as well as one of the most important which goes on in the body. The various actions of an animal body produce relaxation and waste, which are indicated by fatigue and hunger. To restore the one, rest is required, and to restore the other, food becomes necessary. For the herbivorous tribes, vegetable matter is sought for, which being collected, is masticated by the grinders and mixed with saliva, until it becomes a softened mass, when it is passed backwards by the tongue and molar muscles, through the arch of the palate, in the form of a bolus. Received into the pharynx, which rises to receive it, and the action of which forces down the epiglottis, all impediment is removed to its falling in the open funnel of the œsophagus; which having received it, the spiral fibres of the œsophagus force it inwards into the stomach. While the food remains within the cuticular part, it is acted on by pressure; but being further removed, it meets the action of the gastric fluid, by which it is reduced to a pulvaceous mass called chyme. In this state it is passed into the small intestines: for in the horse, as before observed, the process of digestion is by no means completed in the stomach, as in man and many animals. The exertions of the horse require that he should eat largely and nutritiously, but the bulky viscera of the ox would have ill suited with his necessities; for he is not only strong, but his motions are designed to be quick also: it was therefore necessary that some speciality should occur to meet these seeming discordances. This consists in the mode of digestion, which being but partially completed in the stomach, requires a less bulk in that organ, the intestines participating in the labour. A horse will eat two or three pecks of corn or ten pounds of hay at a meal, and yet in a natural state his stomach will not hold half of either. He will also drink two pails of water, when the same organ cannot hold one. What is taken into the stomach is therefore quickly passed through it, and more is required. A horse cannot fast long without injury and pain; his food does not produce a lasting effect in the constitution as animal food does on the Carnivora. A dog fed once a day will thrive, and, when fed every other day only, will not suffer materially; but no horse fed once a day would support himself: even oxen and sheep, as having a slower digestion and more intestinal room, can bear fasting better than the horse. As an animal destined for quick as well as great exertions, his wants prompt him to take in a moderate portion of food only at a time, which his digestive powers peculiarly fit him to convert into nutriment quickly and efficaciously, by distributing the task through a long tract of canal; instead of confining it, as in man and the Carnivora, to one simple organ, the stomach.

6405. *The chyme passes into the duodenum from the stomach*, where it receives the addition of the pancreatic and biliary fluids, whose ducts open into that part of the intestinal tracts. Conducted onwards by the creeping *peristaltic motion*, it passes through this long alimentary tract rather rapidly in the horse; but it remains sufficiently long to receive further additions from the secreting surfaces of the smaller intestines, and probably to have its work of division and absorption begun in it. Arrived at the larger part of the intestinal tract, it is purposely delayed to be fully strained and separated, the open mouths of the lacteals spread over the villous surface receiving the nutritious part under the name of chyle, and the residue being carried backward, and thrown out as dung. The chylous orifices belong to minute tubes termed *lacteals*, which pass onwards enveloped in membranous folds termed *mesentery*, until uniting in one trunk called *thoracic duct*, their contents are poured into the heart, whereby they become mixed with and converted into blood, producing an increase to its quantity; as the alteration it receives in the lungs is an amelioration of its quality, which it has been shown is equally necessary to the animal.

6406. *The liver may also be considered as a digestive organ* (*fig. 833. b b*), inasmuch as it secretes a fluid whose office appears to be to quicken the action of the intestines; at the same time that perhaps the very matter separated tends to purify that blood which has been already distributed to the chylopoetic viscera. All other animals, except the horse, ass, and deer, are furnished with a receptacle for the bile, where it may be retained and rendered more acrid: but the horse has no gall bladder, and, in his fetal state, another speciality presents itself in this organ, which is, that he is deprived of a *canalis venosus*, and thus the whole of the abdominal blood flows through the liver. From this simplicity of structure in the horse he is seldom affected with obstructed or concrete bile; but the organ itself is liable to inflammation, and also to a chronic disease of it through the medium of the stomach.

6407. *The pancreas is an assistant to digestion* also, as we have reason to conclude by its pouring its contents into the duodenum with the bile. It is situated behind the liver, between the stomach and left kidney.

6408. *The spleen, or milt* (*fig. 833. d*), is a spongy body situated at the greater extremity of the stomach. Its use is likewise not clearly ascertained; but it has been supposed to be that of a reservoir of blood for the stomach.

6409. *The kidneys are two excremental glands* (*e e*) situated in the lumbar region, the right more forward than the left. The structure of the kidneys exhibits an external reddish part, an internal whitish part, and a cavity called the pelvis. From this cavity passes out the duct called the urèter, and brings with it the urine which is secreted within the kidney. The *urèters* convey the urine to the bladder.

6410. *The urine appears to be a fecal separation from the blood*, and is in some measure connected with the skin in its office. Thus, when the perspiration is great, the urine is less; and on the contrary in winter, when the perspiration is small, the urine is more considerable. The kidneys of the horse are more easily stimulated into increased action by *diuretics* than those of man or of most other animals; and substances which would not appear potent act with violence on his urinary organs. Thus mow-burnt hay, kiln-dried oats, &c., will produce diabetes.

6411. *The bladder of the horse* (*fig. 833. i*) is a membranous sac for the reception of the urine. It rests on the pùbis, and is immediately under the rectum. It is in part muscular, by which it can expel its contents almost to the last drop. At its neck is a kind of sphincter to prevent the involuntary escape of urine, and at its posterior part it is pierced by the urèters. To the bladder is attached a membranous pipe called the *urèthra*, which passes through the penis, and by that means ejects the urine.

SUBJECT. 14. *The Fœtal Colt.*

6412. *The reproductive system* is one of the most important of nature's works; and, whether we examine the subject anatomically or physiologically, we shall be convinced that the utmost wisdom and care have

been displayed to perfect the continuance of the species. The tender embryo, produced by the mutual sympathies of both parents, becomes placed in a situation the best adapted to its necessities and safety.

6413. *Pregnancy and evolution of the foetus.* In the pregnant womb, the rudiments of the future animal are covered with expansions from the neighbouring parts; and derive nourishment from a communication with the mother by means of the umbilical cord, and farther, by a surrounding fluid. In this state a speciality is observed in the foetal sanguineous circulation; the whole of its abdominal blood passing through its liver (5733.) by which it gains a more early and perfect evolution to fit it at its first entrance into life for active exertions. Under these circumstances it daily acquires increase, until the distention it occasions becomes too great for the capacity, when the muscular fibres of the uterus, powerfully assisted by the diaphragm and abdominal muscles, contract, and thus force both the foal and the membranes into the world.

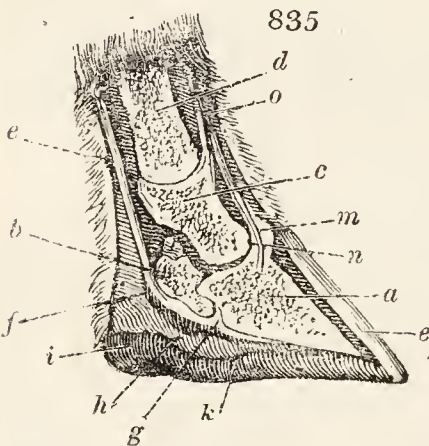
6414. *The new-born foal,* on its entrance into active life, finds its organs of immediate necessity in a full state of capacity. Unlike the infant, it is far from indigent, but can run and perform the common phenomena of an animal with dexterity and ease. Its powers are, however, not sufficiently developed to enable it to live independent: it has therefore a necessity for seeking support from the mother, in the form of milk; and it may therefore be now considered in some measure as carnivorous. The milk is derived from a bag furnished with two nipples, having excretory outlets and valves to prevent the accidental loss of the fluid. These valves the instinct of the foal teaches it to displace by its nose. The milk of the mare being highly nutritious, its evolution rapidly increases and becomes fitted to perform all the more matured functions, and when fully able to counteract its own wants, it sympathises only with itself; when the parent's care being no longer necessary, the lactiferous secretion ceases.

6415. *The period of gestation* varies in different mares: one hundred and two mares were observed by Tessier, of which 3 foaled on the 311th day, 1 on the 314th, 1 on the 325th, 1 on the 326th, 2 on the 333d, 47 from the 340th to the 350th, 25 from the 350th to the 360th, 21 from the 360th to the 377th, and 1 on the 394th day; which gives a latitude of 83 days in the time of gestation.

SUBJECT. 15. *The Foot.*

6416. *The feet of the horse present in their united functions a series of springs* with great complexity of structure. An unreflecting observer considers only the horny box, and perhaps attaches as little merit to its mechanism, as he would to a well turned wooden leg of a man. But a little examination will convince him that all the complexity, all the admirable mechanism displayed in the assemblage of four fingers and a thumb, are here concentrated within this horny box and its appendages. As the parts which compose the hind and the fore feet do not materially differ, a description of one foot will serve for the whole.

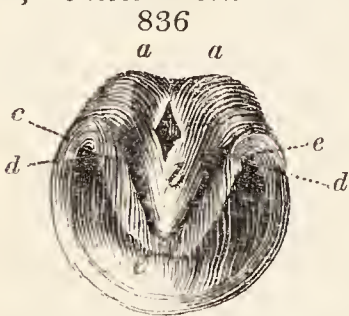
6417. *On examining a perpendicular section of the foot and pastern* (fig. 835.), there appears the coffin bone (a), the navicular or nut bone (b), the coronary or little pastern bone (c), the larger pastern bone (d), the back sinew or great flexor tendon of the foot (e), the same tendon sliding over the navicular bone (f), its termination or insertion into the bottom of the coffin bone (g), the elastic matter of the sensible frog (h), the insensible or horny frog (i), the horny sole (k), which includes the parts of the sensible foot; the outer wall of the hoof (l), the elastic processes (m), the attachment of the extensor tendon to the coffin bone (n), and its attachment to the coronary bone (o), which completes the section.



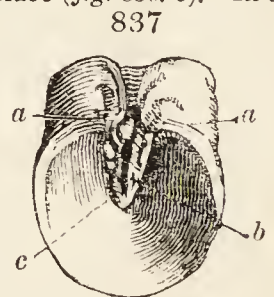
6418. *The coffin bone* (fig. 835. a) adapts itself to the form of the hoof, or rather is adapted by nature to this eligible form. The eminence in front receives the insertion of the tendon of the great extensor muscle of the foot, whose upper attachment is to the humerus or arm bone where it is fleshy, but as it passes onwards, it becomes tendinous, expanding over every joint, both to prevent friction, and to embrace and give attachments to each bone, by which a simultaneous movement of the whole limb is made. In the hinder limb, this extensor and its two less adjuncts arise from the tibia and in part from the femur. To the sides of the coffin bone are attached the lateral cartilages, and around its surface are marks of the attachment of the laminated substance.

6419. *The coronary or small pastern bone* (c), articulates with the coffin at its posterior part, and articulating also with both these is the *navicular or nut bone* (f), whose attachments to them are effected by ligaments.

6420. *The hoof is conical,* or rather, as Clark observes, slightly truncated, and is a secretion as well from the vascular parts of the foot as from the skin, as our nails are from the portion of skin called the quick. The structure of the hoof is firm and fibrous; externally plane and convex, but internally concave and laminated. The *quarters* are the lateral parts. As the horn approaches the heels it becomes soft, and is reflected inwards. The heels are parted by the *horny frog* (fig. 836. b), and without the frog on each side, the hoof inflects its fibres to form the bars which are seen on the under surface (fig. 836. c). In a



healthy foot (fig. 837.) the heels are round, wide, and smooth (a a), the frog fully expanded (b), the bars or binders distinct (c), no corns in the usual angle (d), the sole broad and concave (d). In a diseased foot (fig. 837.), the heels are high and drawn together by contraction (a a), the frog narrow and filled with fissures from contraction and thrush (b), and the sole greatly shortened in its transverse diameter, which is morbidly counterbalanced by the increased heights in the truncated form (c). When the hoof is removed, the *sensible or fleshy sole* (fig. 835. k), above which it im-



mediately lies, presents itself, covering the whole of the horny sole, except so much as is taken up by the *sensible frog* (h). This part is exquisitely sensible and vascular; and thus we learn why injuries to it from punctures produce such serious effects, and why very slight pressure from contraction of the hoof gives so much pain. The sensible frog and the sensible sole form the insensible frog and sole; but when from pressure, too much moisture, or other causes, the sensible frog, instead of forming horn, secretes pus or matter as in thrush, the structure of the whole becomes injured; and the horny frog, thus losing its support, gradually wastes and decays. It is, therefore, evident that no thrush can be entirely harmless, as is erroneously supposed. Above the sensible frog and sole is the great flexor tendon, or back sinew, inserting itself into the vaulted arch of the coffin (fig. 835. e). This important tendon arising from its parent muscle above the knee, whose origin is taken from the humerus and ulna, in its passage unites with an assistant flexor, but which latter is principally distributed to the pastern bones; while the *perforans*, so called because it is perforated by the assistant flexor tendon, is inserted into the vault of the coffin. In the posterior extremities, the attachments of these two leading flexors, and a smaller *lateral* one, are from the femur and tibia.

6421. *The sensible laminae.* Around the surface of the coffin bone it has been noticed that there are

linear indentations, to which about five hundred semi-cartilaginous leaves are attached. Each of these is received between two of the horny lamellæ which line the interior of the horny hoof: and when it is considered what a vast surface of attachment is formed by these means, the strength of the union will not be wondered at. No common violence can separate these parts, and their use, as so many springs to support the actions of an animal, at once weighty, strong, and extremely agile, must be apparent. The vessels and nerves of the foot are derived from the metacarpal arteries, veins, and nerves, which pass behind the pastern, when the main trunks divide to proceed to each side of the foot, and are ramified from thence throughout. It is a division of the metacarpal nerve on each side of the lesser pastern, or of the larger, as occasion suits, which forms the *nerve operation*, now in vogue as a remedy for founder.

SECT. V. *Diseases of the Horse.*

6422. *The diseases of the horse* are as numerous and as important as his complicated structure, and the artificial state of his present mode of life, would lead one to expect. Until of late the treatment of these diseases was confined to the hands of ignorant farriers, presumptive grooms, or shoeing smiths; and the fate of the animals was commensurate with the wretched treatment they were subjected to. The establishment of a school for the veterinary art has disseminated an improved practice, and spread improved practitioners throughout the country; and we would earnestly recommend an application to one of established reputation in all cases of difficulty and danger. But as it is not always that such a one is within reach, to enable the agriculturist to have in his own hands the means of informing himself, or of being a check on others, we submit a concise view of the diseases of the head, neck, trunk, and extremities, preceded by some general observations.

SUBJECT. 1. *General Remarks on the healthy and diseased State of the Horse.*

6423. *Condition of horses.* Being in condition, in stable language, signifies not only perfect health internally, but such an appearance externally as the philosopher would call unnatural, or at least artificial; while the amateur considers it as an essential requisite to the other qualities of the horse. This external condition is denoted by a sleek, short, shining coat, with a degree of flesh neither bordering on fatness nor emaciation. Even in this sense of the term, *condition* must be varied according to the uses of the animal. In the cart horse, provided there be sleekness of coat, looseness of hide, sound wind, freedom from grease or swelled legs, with good digestion; a fulness and rotundity of bulk, instead of detracting from his beauty or impeding his exertions, will add to the one and assist the other. In the coach horse, the hackney, the hunter, and the racer, a different *condition* is expected, varying in different degrees from that of the cart horse. In both cart horse and racer, it is equally necessary that the various internal organs should be in a state to act uninterruptedly for the benefit of the whole; but, in addition to this, it is necessary to the racer, that the greatest possible quantity of animal fibre should be condensed into the smallest possible bulk; and that the absorption of all useless fat and other interstitial matter should be promoted by every possible means, as essentially necessary to unite lightness of body with full strength and elasticity. It is in the attempts to produce such a state in its full perfection, that all the *secrets of training* consist: but whether a total departure from natural rules, by unnatural heat, deprivation of light, stimulating food, restraint from water, and excessive clothing, are best calculated to promote it, admits of much doubt; and it is to be observed, that the dawn of reason and science appears to be shining through the crevices of these darkened casements; for even at Newmarket the system has lately much relaxed from its artificial rigour.

6424. *To bring a horse into condition*, not only should the purposes he is intended for be taken into account, but also his previous state. If he be taken up from grass with much flesh on him, it is evident that what is required is, to remove the soft interstitial matter it may be supposed he has gained by green food, and to replace it by hard flesh; and also to produce a sleekness of coat and beauty of appearance. To accomplish these ends, the horse should be accustomed to clothing and the full heat of the stable by degrees only; and also by degrees only to the meditated change of food, which is best done by mashes. In two or three days a mild dose of physic may be given, during all which moderate exercise only should be allowed, as walking, but which may be continued two hours at a time. After the physic has set, begin to dress his coat, increase his exercise and his food, and accustom him to an increase of warmth. In four or five days' time again mash him for two days, and give a second dose of physic, a very little stronger than the first. (6544.) After this, still further increase his warmth, his exercise, and his food, by which his belly will be taken up, his flesh will harden, and his coat will begin to fall. A third dose of physic, or urine balls, &c., are only necessary in the training of hunters, &c., and even in these, a gradual increase of exercise, rather long continued than violent, with proper food, will effect the end, if not so quickly, more beneficially to the animal. *To bring a lean horse into condition*, a somewhat different plan should be pursued. If from grass, still mash him for a day or two, by no means stint him in his water, and with his mash let corn be also soaked. If corn be speared or malted, it will produce flesh sooner. But even here, give the horse moderate walking exercise, and if he be not too much reduced, add a mild dose of physic to prevent his heels flying, or his getting hide-bound by the increased food; but if great emaciation forbid the physic, give him nightly an alterative. (*Vet. Pharm.* 6550. No. 1.) As his appearance improves, gradually harden his food and increase his exercise.

6425. *Diseased condition of horses.* What has been already said relates to that alteration from one state to another, neither being an unhealthy one, which custom has rendered necessary; thus a man in training for running or fighting, and a man out of training, are both considered equally healthy. But there are circumstances that produce a *morbid state of condition*, different from all these. It is common to hear persons say, "My horse is sadly out of condition; and I cannot tell either what is the matter with him, or how to get him into better case." Various are the causes that may produce this: a sudden alteration of the food or temperature, or of habits altogether, may become a cause. Removing a horse from grass to a heated stable, full feeding, and hard exercise, will often do it: therefore these changes should always be gradual. Bad food, as mow-burnt hay, musty oats, beans, &c., likewise mineral waters, foul air, &c., are frequent causes. Diabètes, or profuse staling, is often brought on by these means, and the *condition* of the horse becomes greatly reduced. It is requisite, therefore, to enquire whether any of these errors are in existence, and to immediately remove them: but it often happens that the stomach has become relaxed and the hide become bound; neither of which readily remove, even though the original evil may be amended. When the relaxed stomach has produced lampas, treat the mouth as described under that disease (6446.); but the stomach itself must be principally attended to. First mash and give a dose of physic; after it has set, commence the treatment, if the horse be of a full habit, by a moderate bleeding and a nightly alterative (*Vet. Pharm.* 6550. No. 1. or 2.) But if he be not in full, but in low flesh, commence by a daily tonic (*Vet. Pharm.* 6551. No. 1. or 2.), which will gradually remove the swelling within the mouth, and loosen the hide. A sudden cold applied to the skin often brings on a want of *condition* with *surfeit*. In which cases bleeding, nightly alteratives (*Vet. Pharm.* 6550. No. 1. or 2.) with or without an assistant dose of physic, as the habit of the horse may require, constitute the proper treatment. *Worms* form another cause of morbid *condition*, which are to be removed as described. (6478.) *Excessive fatigue* is also productive of a bad state of *condition*, which often proves very obstinate. Turning out to very good grass is the quickest cure, and when that is impracticable, soiling in the stable, or feeding with carrots, parsneps, beet-root, &c. will be good restoratives; as medicines give tonics daily. (*Vet. Pharm.* 6551. No. 1. or 2.) It will be only necessary to add, that in considering the state of a horse's *condition*,

the effect is apt to be mistaken for the cause, and the symptoms for the disease. Hide boun l and lampas are not in themselves any thing more than effects, or symptoms; the former being commonly, and the latter being always, dependent on a deranged state of the stomach: both are, therefore, to be treated accordingly. Exactly the same will apply to all the other symptoms of *morbid condition*.

SUBJECT. 2. *Inflammatory Diseases of the Horse.*

6426. *The inflammatory diseases of the horse* are numerous, but his fevers are few; a febrile state being generally brought on by the inflammation of some important organ. Inflammation may be considered as general or diffused, and local or confined, and both seem to arise from an affection of the blood-vessels, and perhaps from a peculiar state of the blood itself.

6427. *General or diffused inflammation* constitutes fever or extensive inflammatory affection, and appears to consist in an increased action of the heart and arteries, accompanied with an increase of heat. In some instances where the fever is purely symptomatic, and dependent on the inflammation of some important organ, as of the lungs or the intestines, the circulation appears retarded rather than increased, from interruption arising to its passage through the heart.

6428. *Local or confined inflammation* is also dependent on an affection of the blood-vessels, but confined principally to the blood vessels of the part affected. It is betokened by redness in the skin, tumour or swelling, heat, and tenderness, with pain. Inflammations, both diffused and local, are brought on by excitements, such as over-feeding, excessive heat, the reaction produced after cold, and the reaction produced by inordinate exertion. Those more exterior arise from injuries, the application of improper substances, &c. Inflammations *terminate* in various ways; but it is to be remarked, that in consequence of the very large circulatory system in the horse, his febrile affections rage higher, and terminate sooner, than in man. The usual termination of inflammatory affections in the horse is, by resolution, effusion, suppuration, and gangrene. Schirrus is not at all a common termination of inflammation in the horse.

6429. *Inflammation of the brain (phrenitis), brain fever, phrensy fever, staggers, mad and sleepy.* There are few diseases more likely to be mistaken by inexperienced farriers than this; it is not to be wondered at, therefore, if indifferent persons should be led into error by it. It appears in two forms, a violent frantic one, and a sleepy lethargic one; and the latter appearance is also common to a disease, not dependent, as this is, on idiopathic inflammation of the brain, but on a paralytic affection of the stomach, and thence it is called stomach staggers. This latter affection, however, may be distinguished from the former by attending to the colour of the eyelids, nose linings, mouth, &c., which, in stomach staggers, are usually more yellow than red; whereas, in sleepy staggers, they are more red than yellow. Inflammation of the brain shows itself, in general cases, by disinclination to food and motion, drowsiness, accompanied by a heaviness and closing of the eyelids, with moisture and redness of them; and also of the linings of the mouth and nose. Sometimes these symptoms increase until the horse becomes comatose, and after a few frightful struggles, he sinks to rise no more. In these cases the pulse is apt to be oppressed instead of increased; but most frequently after the first stages he becomes furious, plunges about, and is vicious to himself and others, approaching to a state of madness, in which state he continues till he sinks from his own exertions, when he rises again to renew his violence.

6430. *The causes of staggers may be various:* the immediate are either an original accumulation of blood within the brain, or the translation of the inflammation of some organ to the brain; as a remote cause it is often brought on by too full feeding, without sufficient exercise, and particularly in horses at one time working very hard, and at another suffered to remain inactive, but which horses, whether used or not, are equally fed. Sudden cold, violence, &c., may bring it on.

6431. *The treatment of staggers* should be begun by abstracting a very large quantity of blood promptly, by opening both jugulars, and letting the horse bleed to the amount of ten or even twelve quarts; repeating the same until the delirium ceases. After the first bleeding, back rake, throw up a laxative clyster (*Vet. Pharm.* 6564.), blister the head, promote a current of free air in the stable, and treat altogether as directed under other febrile affections.

6432. *Locked jaw, stag-evil, or tetanus,* arises from cold, excessive fatigue, sometimes perhaps from worms, but more often from a wound of some part, as pricks in shoeing, &c. Such wound is seldom in a recent state, but after two or three weeks' continuance, sometimes after it has healed even; it follows docking, gelding, and nicking frequently, and is preceded by a flabby unhealthy state of the wound. It is not always produced by an open wound; it is sometimes consequent on a bruise, strain, &c.; and is sometimes brought on by cold, violent exertions, &c. &c. It appears as an affection of the brain, which transmits its morbid irritation, particularly to the nerves attached to muscles, by which they become cramped, or may be considered as in a high state of action, giving the horse a peculiar look of energy, as though immediately stopped from full speed, with his nostrils extended, his head raised, and nose carried forward; his legs straddle wide, and his tail is cocked and quivers, as after violent exercise. The jaws will now be found, if not closed, yet nearly so, when he is called *jaw-set*.

6433. *The treatment* is not often successful; but, however, it is sufficiently frequent that it is so, to deserve the utmost attention. Blaine informs us that enormous bleedings have succeeded; but he places his principal dependence on the application of cold by the means of ice, or of constant dashing with cold water, with an active blister applied the whole length of the spine. Balls of camphor and opium, to the amount of two drachms of each, may be given every three hours. If any room remains in the mouth, the ball may be passed up by means of a stick, or it may be given as a drink by means of a syringe; and even when the mouth is entirely closed, he informs us we may give a drink by the nostrils. Moorcroft used cold also. Fearon, on the contrary, has experienced benefit from a bath, heated to ninety degrees, and kept at that temperature for three hours. White recommends camphor and opium. Wilkinson, of Newcastle, has been very successful by keeping up heat and stimulus over the skin in general, by means of newly stripped sheepskins put on hot. Perhaps if the body were previously rubbed with oil of turpentine one part, and common oil two parts, it might assist Wilkinson's plan. When locked jaw arises from nicking, it might be prudent for a veterinary surgeon to dissect down on the nerves of the tail, and divide them; and when from docking, it would be advisable at once to cut off another portion of the tail; which practices, in both instances, would afford a moderate chance of saving the animal. It is necessary further to remark, that it is of great consequence that the bowels be kept free from fæces, by raking and clysters. With regard to the latter they are very important in this disease, as a medium, commonly the only one, of giving support. A horse has been kept alive on nourishing clysters alone for seven or eight days. (*Vet. Pharm.* 6566.)

6434. *Catarrhal fever, epidemic catarrh, influenza, distemper, cold, morfoundering, &c.* These names apply to one common disease, which often in rainy, variable seasons appears as an epidemic, and affects thousands of horses at once. It is observed to be particularly prevalent in this form in the spring of some years, more than of others. It is not contagious, like the more malignant form, but is brought on as an epidemic by the same causes being applied to nearly all subjects alike; which are alternations of heat with cold, moisture, and dryness, &c. In crowded cities and large towns it is more prevalent than in more open situations, and it is more frequently found in the young than in aged horses. Where it does not exist as an epidemic, it is brought on by an accidental cold taken. It is of great consequence to distinguish it from pure inflammation of the lungs, with which it is very apt to be confounded; and which mistake is often a fatal one, from the treatment being in some essential particulars different. Inflammation of the lungs commences by a short cough, without much other disturbance to the health than the pain it gives the horse to cough; but which is often so considerable as to make him stamp his feet while coughing. If a horse in the distemper coughs early, it is not a hollow, harsh-sounding, and distressing cough of this kind; if he expresses uneasiness, it is principally from a sore throat, which is very common

in distemper, but by no means common in pneumonia. The sore throat in distemper gives the horse a disposition to refuse his food, or he chews it and lets the quid fall without swallowing it. He refuses water, particularly if it be placed on the ground. His cough is quick, short, and usually sounds more moist than harsh and dry; but though common, this is not invariably the case. His eyes are heavy and moist, his breathing is quickened, and his ears and legs are alternately hot and cold. His nose on looking into it is redder than usual, and sometimes his glands, as well submaxillary or jaw glands, as his parotid or vives, are tumified. On the second or third day excessive weakness comes on; the cough becomes more painful, the pulse is quickened, and the nose begins to run. After which the horse either runs off the disease by this suppuration, or it goes on to destroy him by the height of the fever, and degree of weakness produced, or by suffocation from water in the chest. Now and then, although recovery takes place, an obstinate cough is left; and in a few cases the disease terminates in glanders.

6435. *The treatment* may in some cases be cut very short; for as in almost every instance a shivering fit begins the disease, so when many horses are in a stable, and the disease is very prevalent, those who have not been attacked should be watched, and the moment such an attack does take place, give of *sweet spirit of nitre*, or when not at hand of *spirit of hartshorn*, an ounce, in a pint of sound ale. Exercise the horse briskly, then well hand rub him, clothe him warmly, and it is more than probable that the disease will be cut short. But should it proceed, or should the disease have gone on unobserved to the appearance of the symptom detailed, begin by bleeding moderately, if the horse be not already weak, or if there have not appeared the running of matter from the nose. If there have, the bleeding had better be dispensed with, unless the fever appear, from the quick full pulse and redness of the inner surface of the nostrils and eyelids, to be still so considerable as to require it; in which case we must not be deterred from one moderate bleeding; and which, if the febrile symptoms do not abate, may be even repeated. It will, however, in general cases, be advisable to avoid bleeding after the second day of the attack, or after the discharge has appeared from the nose, or after considerable weakness has come on. In all cases a very cool temperature is essentially requisite: hot stables or hot clothing is very pernicious, but particularly the former. A hood is not improper over the head, because it encourages the running to make an early appearance; and for this reason a warm mash may advantageously be hung round the neck three or four times a day. Before the discharge commences, give night and morning the fever powder (*Vet. Pharm.* 6578. No. 1. or 2.) in a mash or drink; after the running has come on, or as soon as the weakness has become considerable, give night and morning either of the fever drinks. (*Vet. Pharm.* 6579. No. 3. or 4.) Malt mashes, when the weakness is great, are proper; at other times bran mashes with plenty of chilled water are best. To relieve the throat, rub the outside with mild liquid blister (*Vet. Pharm.* 6563.); and if the weather be warm enough to allow it, two or three hours turning out in a field each day is proper. Green meat in the stable, when it can be procured, should likewise be given.

6436. *Malignant epidemic, murrain, or pest.* Now and then the distemper or influenza assumes a character of uncommon malignance; which is happily not frequent here, but not unfrequent in continental countries; sweeping off a third of the horses and kine, without any means being found sufficient to arrest its progress. In these cases it is highly contagious, attacking almost all the horses as well as cattle within its sphere of action, or which communicate with each other. Dr. Layard, and Osmer, English writers of established reputation, noticed the appearances of this disease long ago; and their descriptions are not different from the milder kind noticed (6434.) but in degree. The throat is intensely sore, and the mouth ulcerated; the glands of the head swell, and sometimes these and other parts suppurate and burst. The matter from the nose is bloody, and the stench intolerable; the weakness is also peculiarly great, and shows itself early.

6437. *The treatment* recommended by Blaine is the early use of malt mashes; even ale is indispensable. Green meat should be allowed, and a very cool stall is necessary, having a free communication with the open air. As medicine, three doses are necessary, every day, of the malignant epidemic fever drink (*Vet. Pharm.* 6582.); half a pint of yeast with a pint of ale has been given, with good effect, three times a day; also, to prevent the infection from spreading, fumigate the stables and all the outhouses with the preventive fumigation. (*Vet. Pharm.* 6583.)

SUBJECT. 3. Diseases of the Head.

6438. *Epilepsy, megrims, sturdy, or turnsick*, are epileptic attacks of greater or less violence, and which are apt to be confounded with the accidental strangulation that sometimes takes place, from a collar too tight, or from driving a horse hard up hill, &c. The epileptic fit makes its appearance by a sudden stop; if the horse be in action he shakes his head, looks wild and irresolute, but after some time he proceeds; when more violent, he suddenly falls down, is convulsed, dungs and stales insensibly, and remains some time before he recovers. This disease, like staggers, is generally the consequence of too full a habit; and is, therefore, best relieved by bleeding, and a more moderate diet; and, where it is convenient, a run at grass should be allowed to alter the habit.

6439. *The diseases of the horse's eyes* are not numerous, but they are very destructive. The principal are ophthalmia and gutta serena.

6440. *The ophthalmia, lunatic, or moon-blindness*, is a very peculiar disease among horses, affecting their eyes generally about their full growth, but sometimes later, and seldom earlier. It is but little known among mules and asses, and unknown in oxen and sheep. It does not, however, appear to be a disease natural to the horse, as wild ones, or even those little subjected to artificial restraints, are not observed to be subject to it: but among others, it is become so common as to have the tendency handed down in the breed, the progeny of some stallions being more prone to it than others. It is often very sudden in its attack, the eyelids being found swelled and almost closed to avoid the light; they are also very red within, and the haw is half drawn over the surface; the tears flow down the face perpetually, and the whole head is hot: now and then these appearances come on gradually. The suddenness of the attack makes the complaint to be attributed to accident, as blows, hay-seeds within the eye, &c.; and it is frequently difficult to get the owner of such a horse to believe that a constitutional attack, as it usually is, can come on so suddenly. Sometimes as it comes on quickly, so it goes off, the eye, from being opaque and milky, in twenty-four hours becoming clear and almost well. When such an attack has taken place, even if nothing be done, the horse sooner or later amends, and the eye or eyes, — for it is sometimes one, and sometimes both that are so attacked, — become again clear and well, and remain so an indefinite period, from five or six weeks to as many months. Another attack, however, sooner or later follows, to which others succeed, each leaving increased milkiness on the outer coats, and some dimness within the pupil, either speck-like or diffused; and finally the horse becomes blind from *cataract*. When one eye goes blind totally before the other, it is often the means of preventing the future attack on the remaining one; which has given rise to a custom of putting out one eye to save the other, and which has succeeded. As this is a constitutional disease, brought on by artificial habits, as over-exertion, close unhealthy confinement, and heating food; so it is clear the abstraction of all these are necessary to remove the complaint, and to prevent a recurrence; but particularly the close, dark, and unventilated state of the stable should be attended to, as well as the removal of the litter, which retains the volatile alkali of the urine, and irritates the eyes most injuriously. The food should be mild and cooling, and the exercise moderate, but long continued. Under the height of the attack, however, rest is advisable, with moderate light, which may be still further moderated by keeping over the eye or eyes a thick cloth wet with goulard water. (*Vet. Pharm.* 6575.) Sometimes one quarter of vinegar to three quarters of water has been found a useful application; and whichever is used, the eyes and eyebrows should be kept continually wet with it, which

by exciting evaporation will keep the part cool. A seton may be introduced under the eye or jaw. In some cases, blistering the forehead or cheek is found useful; but in every instance bleeding is proper, which should be repeated until the disease lessens. When the horse is very full and gross, physic and alteratives assist the cure. When blistering is used in any part near the eye, the greatest care is requisite to prevent the blistering matter from being rubbed into it. A very peculiar ophthalmic affection is also sometimes occasioned, particularly to the horses of hot climates, by the entrance of a filaria or thread-worm into the globe of the eye, which swimming about in the aqueous humour, eventually occasions violent inflammation. The cure consists in letting out the aqueous humour with a lancet, when, the filaria escaping with the fluid, recovery follows.

6441. *Gutta serena* or *glass eyes*, so called from the peculiar glassy appearance of the eye, arise from a paralysis of the optic nerve. As the eye is not materially altered in appearance, a horse often becomes blind without its being noticed, until his cautious stepping, quick motion of his ears, &c., give notice of the case. On examination it will be found that the pupil remains dilated, however great the light, and the eye is irrecoverably lost. In the very early stages, blisters to the forehead and stimulants to the eyes (as *white vitriol a drachm, water four ounces*;) may be tried, but with faint hopes of success.

6442. *Pole evil*. This complaint commonly requires the attendance of an experienced practitioner: but the prevention is often in the power of owners, and others about horses; and to this point we shall particularly direct their attention. Pole evil is commonly the effect of accident. Repeated small blows of the manger, or continued pressure from hanging back on the halter, &c., will, if not remedied, produce swelling at the nape of the neck, with some tenderness. In this early state, if the collar be removed, and the part be kept continually wet with vinegar and water, the swelling will often disperse; but if, in spite of this, it proceeds to suppuration, let a vent be made for the matter by a seton (6537.) so that it may readily flow out. Introduce nothing healing, but encourage a free discharge, and it may yet heal at once. When such is not the issue, the disease attacks the ligaments, sinuses form, and the matter burrows under the skin and muscles, when a seton must be introduced from the opening above and should be brought out at the bottom: the seton should be then daily wetted with the liquid blister. (*Vet. Pharm.* 6562.) Should this plan fail, escharotics will be required in the form of the *scalding mixture*. (*Vet. Pharm.* 6586.)

6443. *Strangles, vives, or ives*. This disease has been likened to the human measles; because it usually attacks every horse, and most of them at a young period, between three and five years. It is fortunate when it attacks colts at grass, as it seldom occasions inconvenience, which has led some persons into error by turning their horses out as soon as attacked; but it is not found that stabled horses, thus turned out, pass through the disease more mildly, but the contrary, except the disease exists under its very mildest form. White has conjectured that colts breeding the strangles while at grass are afterwards exempt from glanders, but this wants confirmation. Prosser has also affirmed, that inoculation by the matter of strangles is good; because it mitigates the complaint, and renders the horse not liable to any future attack: but the practice has never gained ground. When the strangles occurs in the stable, and now and then also in the field, it proves a severe disease, and shows itself under the appearance of a cold, with cough, sore throat, and swelling of the glands under the jaws, or behind and under the ears. Sometimes there is not much external swelling, and the tumours break inwardly, and nature effects a cure; at others they break outwardly, and the disease runs off that way; and sometimes the swellings disperse either by nature or art, which breeders think unfavourable, as they suppose it renders the animal liable to a future attack, but many so treated pass the remainder of their lives without more affection.

6444. *The treatment of strangles*. When the swelling lingers, and neither comes forward nor recedes, poultices are preferable to fomentations, which, by leaving the horse wet, promote evaporation and produce cold. Peal recommends blistering the part, as the best means of promoting suppuration. The horse should be kept very cool, and bran mashes with warm water should be his principle support, unless the complaint last long, and produce much weakness, when malt mashes should be substituted. Bleeding is only advisable when the early symptoms are violent, as heaving at the flanks, extreme soreness of throat, with much swelling around it, and considerable cough, in which case bleeding and fever medicines are proper.

6445. *Vives, or ives*, is supposed to be a relic of the latter complaint, and it does appear now and then that after the strangles the parotid or vive glands do remain enlarged (6463.), which occasions the disease in question: resolution may be attempted by mercurial frictions; suppuration should be avoided, otherwise the gland may be destroyed.

6446. *Diseases of the mouth, lampas*. All horses, but particularly very young ones, are liable to enlargement of the rugæ or ridges of the palate, dependent not on any local disease confined to the part itself, but occasioned by an affection of the whole passage of the mouth, throat, and stomach. It is usual to attend to the part only, which is scarified or burnt to little purpose, when a mild dose of physic, or gentle alteratives, would prove more certain expedients; to which may be added rubbing the rugæ themselves with bay salt, or with vinegar.

6447. *Bridle sores*. When the bit in colt breaking, or in hard-pulling horses, has hurt the bars, care is requisite to prevent the bone becoming carious. Touch daily with ægyptiacum, and cover the bit with leather, unless total rest can be allowed.

6448. *Diseases of the teeth* are fully treated of under the anatomical description of the bones. (6305.)

SUBJECT. 4. *Diseases of the Neck.*

6449. *Fistulous withers* are brought on usually by pressure from a saddle with too low or narrow a saddle-tree; and what has been said both with regard to prevention and cure on the subject of pole evil, will equally apply here also. (6442.)

6450. *Sore throat* is common to horses in colds, in influenzas, and in strangles. (6434. 6443.) It is discovered by the horse chewing his hay, but instead of swallowing he drops it from his mouth, or, as it is called quids it. He likewise shows a disinclination to drink. In every case, the horse finds great difficulty in reaching every thing that stretches his neck downward or upwards; his water therefore should be held to him, and his hay should be pulled for him: omission of these services greatly aggravates the sufferings of horses labouring under sore throat.

6451. *Swelled neck*. A very serious swelling sometimes follows on bleeding with a rusty or poisoned lancet, or fleam, and sometimes also from causes not apparent. (6547.)

SUBJECT. 5. *The Chest.*

6452. *Inflammation of the lungs* is a disease to which the horse is peculiarly liable; as we might *a priori* suspect, from the vast dimensions of his circulatory system, and the vast alteration from a natural state to which we subject him, and thereby increase his pulmonary circulation.

6453. *The causes* are these deviations remotely, but the immediate attack is generally brought on by sudden cold, acting on a heated surface; and thus it is that knackers and collarmakers in frosty weather expect a glut of horses that die from this disease. Hard riding is a very common cause, and high feeding also. It often commences slowly, a hard dry cough has been slightly noticed, but which has occasioned no alarm for two or three days: gradually, however, the cough appears to give the horse pain; he occasionally shivers, and his ears and feet feel colder than the rest of his body; he heaves at the flanks, and the lining of his nose is found to be much more red than usual, in the worst cases it is seen of a purplish hue; the

inside of the cyclids also are tinged with the inflammation. The appetite now becomes affected; and although there is not much apparent pain, except when the horse coughs, yet there is much anxiety of countenance present. The pulse is usually small but quick. If in this state the horse accidentally or erroneously be taken out and subjected to considerable exertion, it is almost always fatal to him: it likewise happens that this complaint is sometimes mistaken for distemper, and, from a fear of profuse bleeding, the only remedy that is to be depended on is omitted, and the horse is lost. At the veterinary college, in these cases, a small dose of aloes is given every six hours, and after being bled and rowelled, the horse is turned out in the open air; and it is affirmed that many recover from this treatment. Certain it is, that the stable in which a horse is placed in this disease can hardly be too cool; but when entirely turned out, his feet and legs cannot conveniently be hand-rubbed, or bandaged up to promote circulation; neither can we blister a horse when turned out, so conveniently; and on blistering we depend as the second source of cure.

6454. *The treatment* is to be commenced by attempts at lessening the action of the arterial system by early and large bleedings, as seven or eight quarts from a large horse, and which should be repeated in five or six hours if he be not relieved in his breathing. Immediately rub into the brisket, on the chest, and behind the fore legs, the blister. (*Vet. Pharm.* 6559. No. 1.) Give half a dose of physic, and assist it by mashes and warm water, which, if not readily taken, horn down. Back-rake also, and throw up the laxative elyter. (*Vet. Pharm.* 6564.) Avoid all exercise, clothe moderately, allow a free circulation of cool air through the stable, and rub the legs frequently; and when not under this process, keep them bandaged up to the knees with hay-bands or woollen cloths. When the bowels are opened, give the fever drink (*Vet. Pharm.* 6580.) three times a day. The terminations of this complaint are various. It is not uncommon for the horse to appear better, to eat and to drink, and to excite every hope of a perfect recovery; but on some sudden exertion he falls down and expires. On examination after death, it is found that effusion of a large quantity of serous fluid has taken place in the chest.

6455. *Thick wind is another termination of pneumònia*, by leaving the bronchial passages charged with coagulated blood. Moderate exercise and soiling in the stable, with mild mercurial physic, form the best mode of treatment; but frequently the cough resists all these, and terminates in broken wind.

6456. *Roaring is also a termination of pneumònia*, in which case the lungs are not affected, but coagulated blood, under the name of coagulable lymph, remains in the trachea or windpipe, and obstructs the free passage of the air; by means of which the roaring noise is made. It is in vain to expect a cure: blistering the throat sometimes slightly relieves it.

6457. *Chronic cough is also a termination of pneumònia*, and appears dependent on a peculiar irritability the disease leaves in the bronchial passages, which are found afterwards incapable of bearing any sudden alteration of temperature: thus horses with this kind of cough are excited to it as soon as the stable door opens, and by every exertion, by drinking, by eating, and, in fact, by any thing that alters the situation of the body, or is new to the part. But, besides pneumonia or inflammation of the lungs producing it, it is often brought on likewise by gross feeding, which, weakening the stomach, impoverishes the blood, and thus injures the lungs which are fed by that blood. Worms also by the same means are a cause of chronic cough. It is thus that we expect to derive benefit by mediums acting on the stomach. Green food is often found useful, but particularly carrots. The hay should be excellent in quality and small in quantity; and it will be found that soiling in the stable, but particularly a course of carrots, forms a better plan of treatment than turning out. If worms be suspected, treat as under that head. (6478.) Formulæ of chronic cough balls are seen in the *Vet. Pharm.* (6569.)

6458. *Broken wind is also sometimes brought on by pneumònia*, and sometimes by occult causes. It is often occasioned by over-exertion after full meals, in which the lungs become permanently weakened, perhaps ruptured, in their air-cells. Inexperienced persons find some difficulty in detecting broken wind from other chest affections, as chronic cough, occasional colds, &c. &c.

6459. *Criteria of broken wind.* The cough which accompanies broken wind is a short deep hollow grunting noise, and the short grunting expiration is peculiarly excited by turning a horse quickly round, striking him smartly with a stick at the same time, which often produces the deep sound without the cough; and which is so significant as never to be mistaken when once heard and attended to: but the principal peculiarity arises from the beating of the flanks, which operate rather by three efforts than by two as usual. In the first, the air is drawn in, in the usual manner, and the flanks fill up as in common: but in the next, the falling of the flanks is by no means natural; for it is not done by a gradual sinking of the sides, but it takes place at once, with a kind of jerk, as though the horse were sighing; and then a third effort takes place by a more slow drawing up of the muscles of the belly and flanks, to press out the remaining air. Broken wind usually destroys the fecundity of the mare, and hence argues permanent alteration of structure; it is also always incurable, but horses may be rendered very useful that have it, by feeding them very nutritiously, but with their food much condensed in bulk. Little hay should be allowed, and that little should be wetted, water in any other way should be given but sparingly, for which they are however very greedy: from which circumstance, as well as that they are peculiarly flatulent, we learn, that the vitiation of the lungs is either aggravated by the deranged state of the digestive organs; or, which is more probable, that the digestive powers become weakened from the state of the lungs. In some few cases a partial rupture of the diaphragm or midriff has been observed in broken wind.

6460. *Diseases of the belly.* Inflamed stomach seldom attacks the horse as an idiopathic affection, but it is not unfrequent for the stomach to become inflamed by mineral poisons as well as rendered inert by vegetable ones. Over-distention may also inflame it.

6461. *Mineral poisons inflame the stomach* acutely, and produce excessive distress, and cold sweats; the animal lies down, rolls, gets up again, looks short round to his ribs, stamps with his fore feet, and his pulse beats quick and short. When arsenic or corrosive sublimate have occasioned the malady, a viscid mucus distils from the nose and mouth, and the breath is fetid. When copper in the form of vitriolic salts or verdigris has been given, to the foregoing symptoms are usually added ineffectual attempts to vomit. Immediately the poisoning is discovered, pour down two ounces of *sulphuretted potash*, in a quart of water; or in the absence of that, an ounce of common potash in the same quantity of water: or when no better substitute is at hand, even strong soap-suds are advisable. Mineral poisons have also another mode of acting, and are often received into the constitution, neither by design to do mischief, nor by mistake; but are purposely given as remedies. In this way, both mercury and arsenic are frequently given for worms, glanders, farcy, &c., in daily doses, which, when even of considerable magnitude, occasion for many days no inconvenience; all at once, however, the constitution becomes fully saturated with the poison, and although before diffused throughout the blood, it now appears to return and act on the stomach to the great surprise of the owner. In these cases the symptoms are not usually so violent as in the former instance, but they are equally fatal. A similar treatment with the one already prescribed is necessary; and as soon as the first symptoms are abated, give laxatives. In all these cases, large quantities of linseed tea should be horned down, the back should be raked, and clysters thrown up; blood should also be taken away plentifully. As a preventive to this latter mode of poisoning, whenever mineral agents are used, it is prudent every five or six days to stop a while, and then recommence, by which the constitution will part with the previous quantity.

6464. *Salivation is also another mode of poisoning*; and though not equally injurious to the stomach, it often proves distressing, and sometimes fatal. Whenever, therefore, mercurials are given, carefully watch the gums, and as soon as they look red, and the horse quids his hay, give him a mild purge instead of his mercurial.

6463. *Vegetable poisons also inflame the stomach*; but by no means in an equal degree with the mineral poisons; nor is it supposed that it is the inflammation they raise that proves destructive, but by an effect

communicated through the stomach to the nervous system. *Digitalis purpurea* or foxglove, *Taxus baccata* or yew, *Cenánthe crocata* or water dropwort, *Cicuta virōsa* or water hemlock, *Phellandrium aquaticum* or water parsley, *Conium maculatum* or common hemlock, are all poisonous in a high degree to horses, and may be taken accidentally by the animal as food, or given injudiciously as medicine. *Nicotiana* or tobacco, and the vegetable acid or vinegar, are also poisonous, and are sometimes productive of injurious consequences by over-doses, when intended as remedies. It is little known that a pint of strong vinegar has destroyed a horse. As we cannot remove the matters from the stomach, we must endeavour to neutralise their effects by acids and demulcents, as oil, butter, &c. : thus, when narcotics have been taken, a drachm of sulphuric acid or oil of vitriol may be given in a quart of ale; or six ounces of vinegar, with six of gin, and a quart of ale, may be tried. An excellent domestic remedy might be found in two ounces of flour of mustard mixed with ale or other fluid.

6464. *Stomach staggers.* This peculiar complaint, which is even yet but little understood, appears dependent on a particular state of stomach, acting on particular foods; and not on what is taken in acting on the stomach, as was supposed by Coleman, White, and others. From later communications of White, he also now appears to consider it as originating in "a peculiar state of stomach." Blaine appears always to have characterised it as "a specific inflammation of the stomach." It appears among horses of every description, and at grass as well as in a stable; and there is reason to think it epidemic, as it is prevalent in some seasons more than in others. It may, perhaps, be regarded now and then as endemic also; under which circumstance it appears confined to low wet situations, where long marshy grass is abundant, and where noxious aquatic plants mix themselves with the grasses. When it occurs at grass, the horse is found stupidly dull or asleep with his head resting against something. This has occasioned the disease to be called the sleepy staggers: and it has often been confounded with the phrenitis, or inflammation of the brain. (6429.) In the stable the horse dozes, and rests his head in the manger: he then wakes up and falls to eating, which he continues to do until the distention of the stomach becomes enormous; for the peculiarity of the complaint consists in the total stop that is put to digestion, and the uneasy feel of the distention consequent to such indigestion appears to deceive the horse, and by a morbid excitement to force him to take in more. In this way he continues eating until the distention prevents the return of the blood from the head, and the animal dies apoplectic, or his stomach bursts with over-distention. More frequently, however, the stomach becomes flabby, inert, and paralytic, and after death presents marks of inflammation towards the pylorus.

6465. *The treatment.* When recovery has taken place, it has occurred only when the disease has been very mild, and has been assisted by stimulating the stomach into action by purgatives, at once active and invigorating, as an ounce of aloes dissolved in half a pint of gin. When a horse of extreme value is attacked, croton oil might be tried to the amount of 20 or 25 drops in two ounces of tincture of aloes. Warm water in small quantities, or mixed with common salt, should be frequently passed down. Remove every eatable; rake, clyster, and hand-rub; and, if the determination to the head be extreme, bleed, otherwise avoid it.

6466. *Inflammation of the bowels, enteritis, or red colic,* is a very distinct disease from the gripes, gullion, or fret, with which it is, however, very apt to be confounded to the destruction of many horses. The peritoneal inflammation of the bowels, the one here treated on, is an affection of their outer covering.

6467. *The causes are various.* It is not unfrequently brought on by a sudden translation of cold after great heats, as swimming during hunting, or from the removal of a horse from grass at once into heated stables; neglected gripes, or long-continued costiveness, excessive riding, and the immediate drinking of cold water, have brought it on. It begins by restlessness, loss of appetite, and some uneasiness; the mouth is hot and dry; the inner membranes of the mouth, nose, and eyelids are often redder than natural. As the disease advances, the pain, before not violent, now increases so as to force the horse to lie down and rise again frequently; and when very violent, he kicks at his belly, or looks round at his sides, pawing his litter very frequently. The pulse is usually small, quick, or hard; sometimes it is more full and small, but always hard. Breathing is quickened, and the flanks heave; the extremities are alternately hot and cold, but continue longer cold than hot; and the animal is costive: sometimes pain may force away a few hardened balls of feces, but the principal contents are retained. Blaine has given the distinguishing features between this disease and colic, under which head we have stated them.

6468. *The treatment* must be active and immediate, or a fatal termination may be expected. Begin by abstracting a considerable quantity of blood, from a large horse to the amount of seven or eight quarts; proceed to back-rake; throw up a large clyster of warm gruel. Give by the mouth, if the expense be not considered an object, a pint of castor oil, mixed by means of the yolk of two eggs, with half a pint of broth or gruel. If the expense be objected to, give olive oil instead, following it up in half an hour by a gruel drench, in which six ounces of Epsom salts have been dissolved. A sheep-skin, immediately as it is removed from the sheep, may be applied to the belly, which should first be well rubbed with the stronger liquid blister. (*Vet. Pharm.* 6562.) In four hours repeat the bleeding; if a considerable improvement have not taken place, and if the bowels be not unloaded, give more oil, and clyster frequently, having first back-raked. Avoid exercise; first hand rub, and afterwards wrap up the extremities to the knees. As a clear passage for the dung is found, the symptoms mitigate, and the animal slowly recovers; but he must be fed at first very sparingly.

6469. *Inflammation of the inner surface of the intestines* is, in some measure, different from the former, which, as before stated, is an affection of their outer covering; whereas this is usually confined to their villous surface, and may be brought on by superpurgation from over-strong physic, or from mineral acids being taken in, particularly mercurials, which often exert more influence on the bowels than on the stomach. It differs from the former in the symptoms being generally accompanied with purging; neither is there usually so much pain or uneasiness present, nor such cold extremities; but where from the violence of the inflammation these symptoms are present, bleeding to the amount of three or four quarts is a proper preliminary, but can hardly be with propriety continued. The same stimulants to the outside of the belly should be used as in the last disease; but here, warm general clothing is recommended as well as warmth in the stable, as also hand-rubbing to keep up the circulation in the extremities. Give astringent drink (*Vet. Pharm.* 6552. No. 1. or 2.) with a pint of boiled starch every three hours, and give the same by clyster with two quarts of pot liquor, or tripe liquor, free from salt.

6470. *Dysenteric inflammation of the horse's bowels* is happily not very common, but now and then appears, and is then called by farriers molten grease; they mistaking the morbid secretion from the intestines, for the fat of the body melted down and passing off thus: but dysentery is a peculiar inflammation of the mucous surface of the intestines, not contagious as in the human, nor epidemic, nor exhibiting a putrid tendency; but is peculiarly confined to a diseased increase in the mucous secretions, yet very different from simple diarrhoea, which is a mere increase in the peristaltic motion, by which the common aliments are quickly passed through the intestines, and ejected in a liquid form by an increase in their watery secretion. Whereas in the dysentery of the horse, the mucous of the intestines separates from them in large quantities, and comes away with the dung surrounding it; but when it does not pass in this way it appears in membranous films like sodden leather, or in stringy evacuations, like morsels of fat floating in water; sometimes there is a little bloody appearance. The usual symptoms of fever are always present, but not in a very high degree.

6471. *The causes* are cold, over-riding, and not unfrequently acrid substances within the intestines: change of food has occasioned it, and now and then superpurgation from strong physic.

6472. *The treatment.* In the first stages bleed considerably, and give, as the first internal remedy, six ounces of castor oil, which will amend the faecal evacuations considerably; afterwards administer the

following: — *Powdered ipccacuanha, a drachm; powdered opium, a scruple; liquid arrow-root, eight ounces.* Should this not check the evacuation, and should it continue as mucous as at first, again give castor oil, and then follow it up by either of the drinks directed for the cure of scouring or looseness. (*Vet. Pharm.* 6552.)

6473. *Diarrhœa or looseness.* This complaint originates in an increased peristaltic motion of the intestines, with an increase of their watery secretion, and is distinguished from dysentery by the purging being complete from the first, and seldom occasioning much fever or disturbance in the general health, unless exceedingly violent. The stools are merely solutions of the aliment, and unmixed with membranous films as in dysentery or molten grease. It sometimes succeeds to over-strong physic; at others the food itself enters into new combinations, and forms a purge. Some horses have their bowels constitutionally weak, as lank-sided small-carcased ones, where the mechanical pressure hurries the contents forwards. Salt mashes and sea water will purge horses violently sometimes. In violent cases, horn down liquid starch, and throw up the same by clysters. Give astringents (*Vet. Pharm.* 6552. No. 1.) two or three times a day; keep the animal warm and quiet. In the milder cases and in habitual scouring change the food. The change should be generally from one more moist to one less so, as beans, &c. Barley will sometimes stop looseness; malt usually increases it. Buck-wheat is often a check to habitual diarrhœa. Efficacious astringents will be found in the *Vet. Pharm.* (6552.) Repeat either of these night and morning. Give but little water and that little warm.

6474. *Colic, flatulent or spasmodic,* called also *gripes, fret,* or *gullion,* is an important, because a frequent, disease, and because it frequently destroys either quickly by its irritation, or by its degenerating into the red or inflammatory colic, when improperly treated or long continued. It is usually very sudden in its attack.

6475. *The causes of colic are not always apparent.* It is sometimes occasioned by intestinal stones, which accumulate to a great size, remaining for years in the cells of the colon, until some accidental displacement occasions an interruption to the peristaltic motion. Cold in its various forms is a parent of colic; but under the form of cold water given when a horse is hot it is most common. In some horses it is so frequent as to become a constitutional appendage.

6476. *The distinguishing marks between colic and inflammation of the bowels* are gained, according to Blaine, by attending to the following circumstances: — In gripes the horse has violent fits of pain, but they remit, and he has intervals of ease. The pain in red colic is more uniform and less violent. In gripes, the pulse is, in general, natural; in red colic it is quicker than natural, and commonly small. The extremities are not usually cold in gripes; in red colic they usually are. In gripes, the horse attempts to roll on his back, which in red colic he seldom does. There are no marks of fever with gripes, as red eyelids, inflamed nostrils, &c.; but in red colic they are always present. When spasmodic colic has continued some hours, it is always proper to bleed to prevent its ending in inflammation: bleeding in the mouth is quite useless. Back-rake, and throw up clysters of warm water, one after another, as fast as possible, which often overcomes the irritation. La Fosse recommends a curious remedy; but as it can always be obtained, and has the sanction of long experience, it may be tried. An onion is pounded and mixed up with some powdered savin; in default of which, use powdered ginger. This is to be introduced up the rectum as high as possible, and the horse is to be then moved briskly about. An onion put up the fundament whole has long been a domestic remedy. The following is recommended by Blaine: — *Spirit of vitriolic æther, an ounce; powdered opium, one drachm; oil of turpentine, three ounces; warm ale, a pint.* He also recommends the following more simple remedy as always at hand: — *The expressed juice of two or three large onions, common gin, common oil, of each half a pint; mix and give.* White recommends a pint of brandy, or of gin, with water, as an excellent carminative. Clark, who has expressly written on gripes, extols the virtues of a mixture thus made; which, if it have the qualities he attributes to it, and which there is no reason to doubt, no agriculturist, coach or post master should be without it: — *Pimento berry, called also allspice, ground fine, half a pound; spirits of wine, and of water, of each a pint and a half: infuse these together, and keep for use.* Give a quarter of a pint every hour until full relief is obtained; hand rubbing, wiping, or fomenting the bowels with hot water at the time.

6477. *Inflammation of the intestines from wounds in the belly* frequently occurs; and these injuries may happen in leaping over hedges or pale gates, or may be inflicted by the horns of a cow. Sometimes the strong tendinous covering of the belly is ruptured, while the skin remains entire; the gut then protrudes and forces out the skin into a tumour. The first thing to be done is to put the gut back, taking care at the same time, otherwise extensive inflammation follows, to remove any dirt or other matter that may be sticking to it; for which purpose, should it be found necessary, it may be washed with warm water, but with nothing stronger. If the gut cannot be returned, from its being full of air, and the opening in the belly be too small to put it back again, such opening may be carefully enlarged to the necessary size; but if the animal can be thrown upon his back conveniently, a great deal may be done that cannot otherwise be accomplished. After the gut is returned the skin only should be stitched up, and a cushion of several folds of old linen and tow being placed in the wound, it should be kept in its situation by means of a wide bandage rolled round the body, and carefully secured. The animal should then be copiously bled, and have his bowels emptied by clysters. The only food he should be allowed is grass, or bran mashes, and that only in moderate quantity. When the distention of the intestines wholly prevents their return, it would be prudent to puncture them with a very fine instrument, and thus to suffer the air to escape, which, although subjecting the horse to the risk of inflammation, is better than the certainty of death by having the intestines protruded.

6478. *Worms of horses* are of several kinds. First, bots in the stomach; but which, as they mostly attach themselves to the hard insensible part of that organ, seldom do harm. Clark fancifully supposes they do good, and devises means for furnishing them when not in existence. The *bot* is the larva of the *Æstrus equi*, a fly which deposits its eggs, it is supposed, on the grasses on which horses feed, and probably on parts of the horse himself, from whence they pass into the stomach by the food or by being licked off. Certain it is they get there, are hatched, and there remain hanging to the coats of it by two tentaculæ, receiving the juices of the masticated food as nutriment. After a considerable time they make their way out by the anus, drop on the ground, and are first transformed into chrysalids, and afterwards into parent flies. When bots fix themselves on the sensible portion of the stomach they may do harm; but no medicine that we know of will destroy them. The *tères*, or large round worm, sometimes occasions mischief, when it exists in great numbers, such as a staring coat, binding of the hide, irregular appetite, and clammy mouth. The best remedy is the *Spigelia marylandica* or Indian pink, in daily doses of half an ounce. *Tænia* are not common in the horse; now and then they exist, and are best combated by weekly doses of oil of turpentine, three ounces at a time, mixed by means of the yolk of an egg with half a pint of ale. The *Ascaris* or thread-worms are best removed by mercurial purgatives. The existence of worms may be known by the appearance of a yellow matter under the tail, and by the disposition the horse has to rub his fundament. Blaine recommends the following vermifuge: — *Powdered arsenic, eight grains; pewter or tin finely scraped; Venice turpentine, half an ounce: make into a ball, and give every morning.* He also recommends salt to be given daily with the food; which agrees with our own experience as one of the best vermifuges known. It is a fact acknowledged by the residents along the sea-coast, that horses troubled with worms will often voluntarily drink largely of sea water, and thus cure themselves.

6479. *The diseases of the liver are acute inflammation or hepatitis, and chronic inflammation or yellows.* *Hepatitis* is the acute inflammation of this organ, which, like the lungs, stomach, and intestines, may spontaneously take on the affection. The symptoms are not unlike those which attend red colic, but with

less violence. If it be not, however, arrested, the termination will be equally fatal. About the third day the whites of the eyes turn yellow, and the mouth also. Bleeding, blistering, and purgatives form the methods of cure as practised in red colic.

6480. *Chronic inflammation or yellows.* The liver of horses is less complex than that of many other animals, and is therefore not very liable to disease; indeed some authors affirm that the horse is never affected with jaundice, but that the yellowness of skin is a mere stomach affection: this is, however, erroneous; and not only does the liver become hardened and thickened occasionally, but the bile becomes diseased and is thrown out in that state by the blood over the body. If fever be present, bleed, but if the symptoms present no token of active inflammation, give each night ten grains of calomel, and every ten days work it off with a mild dose of physic. It is, however, necessary to remark, that it is not every yellowness of the skin that betokens either an acute or chronic inflammation of the liver. It is the property of every serious inflammation of any of the important organs of the chest and belly, to communicate a portion of the evil to the other organs immediately in conjunction with the liver: thus an affection of the stomach or intestines, of the inflammatory kind, very often occasions redness of the membranes of the nose, eyelids, &c. &c.

6481. *Diseases of the urinary organs.* Inflammation of the kidneys is an idiopathic affection, not one of frequent occurrence; but as brought on by injuries, such as over-riding, heavy loads, or violent diuretics, it is not unfrequent: when idiopathic, it may be the effect either of cold, heating food, or a translation of some other inflammation; in which cases, it comes on suddenly, and assumes the same febrile appearances that other intestine inflammations produce; but there is not often great apparent pain, but a frequent inclination to stale, the quantity made being so small as almost to amount to a stoppage of urine, which is less or more complete, as one or both kidneys are affected. What little urine is made is also at first very thick, and then bloody. When the disease is the effect of external injury, the urine is not so scanty, but is more bloody; and this symptom precedes the other. There is usually much pain and stiffness about the loins; and we learn from Blaine, that a swelling and a paralytic affection of the hind leg, of the side of the affected kidney, sometimes is a feature in the complaint. To distinguish this inflammation from that of the neck or body of the bladder, with which it may be confounded, the same author recommends that the hand be passed up the rectum: when, if the affection belong to the kidneys, the bladder, whether full or empty, will not be hotter than usual; but the contrary occurs when any part of the bladder is the seat of the disease.

6482. *The treatment* must be active, and in most respects similar to what has been recommended for red colic, as regards emptying the bowels, and endeavouring to lessen the arterial action by bleeding; but here we must carefully abstain from irritating the kidneys by diuretics internally, or blisters externally. A newly stripped sheepskin placed over the loins, or active fomentations of hot water, are the only sources of counter-irritation that are proper; neither should diluting liquors be pressed, on account of the distention they occasion, but no evil can arise from frequent warm clustering.

6483. *Inflammation of the bladder.* When the body of the bladder becomes inflamed, there is frequent staling from the very first attack; but when the neck of the bladder is the seat of the evil, the squeezing out of a few drops will only take place when the bladder has become filled, which may be known by passing the hand up the rectum. The treatment will be alike in both cases, and is the same as recommended for the last affection. It must be evident, that warm, mild, and frequent clustering must here be peculiarly advisable.

6484. *Strangury or suppression of urine, incontinence of urine, bloody urine.* Strangury may arise from an injury done to the kidneys, or to the bladder, by strains, or by the absorption of irritating matters. In these cases, bleed if there be fever, and if not, merely give the horse absolute rest; mash him, give gruel, and warm his water for drink. *Bloody urine* should be treated in the same way; some horses have such a natural or acquired weakness of kidneys, as to stale blood with their urine on every occasion of over-exertion: the means frequently used for relief are such as aggravate the complaint, and indeed are often the occasion of it, which are diuretics. Strong diuretics injure horses more than strong physic, and benefit them less than any other of the popular means made use of. In retentions of urine, but particularly in the case of bloody urine, they are absolutely improper.

6485. *Diabetes, profuse staling, or pissing evil.* This disease is more frequently forced on the horse by long-continued diuretics, or from a similar effect brought on by kiln-dried oats, mow-burnt hay, and some green vegetables, than acquired from constitutional indisposition. The horse first stales often and profusely, he then becomes weak and faint, and sweats on any exertion. If it be at all constitutional, his hide is bound from the beginning, and his urine will have a sweet taste; but if his appetite were good, and his coat sleek, bright, and elastic when the urine was first observed to be immoderate, the evil arises from some fault in the feeding, clothing, exercise, or other management of the horse. Examine into these matters, particularly into the food, and next the water. Enquire whether diuretics have been given, under an erroneous supposition of increasing the condition, and alter what may be amiss. If this do not remove the complaint, try the following, after Blaine's directions: — *Liver of sulphur, two drachms; uva ursi, four drachms; oak bark, one ounce; catechu, half an ounce; alum, half a drachm*: give as a daily drink in a pint of water.

6486. *Stone and gravel.* Calculous concretions are not uncommon in the large intestines of horses, where they grow sometimes to an enormous size, lodged in one of the cells usually, and where they occasion but little inconvenience, except a displacement occurs, when serious evils, as colic, inflammation, or total stoppage, follow. In the bladder, stone is very seldom found; and there is reason to believe, that though gravel is a common term in the farrier's list, that it seldom if ever occurs; injuries of the kidneys and bladder being usually mistaken for it.

SUBJECT. 6. *Diseases of the Skin.*

6487. *Mange is a contagious disease* not uncommon among low-bred and badly kept horses, but which is seldom generated in those properly managed. When it is the effect of impoverished blood, a different course of feeding must be substituted, not heating, but cooling though generous; as, carrots, speared corn, malt mashes, stable soiling, &c. When it arises in full-fed horses, bleed twice, lower the feeding, substituting for corn soilings, carrots, or barn mashes. Give a nightly alterative (*Vet. Pharm.* 6550. No. 1. or 2.), and dress with either of the mange dressings. (*Vet. Pharm.* 6589.) After a cure has been effected, carefully clean all the apartments with soap and water.

6488. *Surfeit will now and then degenerate into mange*, but more generally it is brought on by a fulness of habit acted on by sudden transitions from cold to heat, or heat to cold; it is likewise not unfrequently the consequence of over-fatigue. If it show a disposition to spread, and the skin become scaly and scurfy, treat as under mange; otherwise treat as directed under want of condition. (6425.)

6489. *Warbles* are of the nature of surfeits in many instances, in others they are brought on by the pressure of the saddle, which either suppurate and burst, or become indolent and remain under the name of *sifasts*. In the early state, bathe them with chamberlye or vinegar: if they proceed to suppuration, refrain; and when they neither go back nor come forward, put on a pitch plaster, and if this do not promote suppuration, let the sifast be dissected out.

6490. *Warts are common to old horses*, and had better be put up with, unless they be situated in some inconvenient or very conspicuous part. In this case, tie a thread tightly around the root, and the wart will drop off, or it may be cut off. Blaine recommends the following, when warts are too numerous to be so removed: — *Crude sal ammoniac, two drachms; powdered savin, one ounce; lard, an ounce and a half.*

6491. *Hide bound is a state of the skin*, where the interstitial matter between that and the fleshy part

nicle is not in a state to allow of its pliancy and elasticity. The binding down of the hide thus closely acts on the hair, which it protrudes in a contrary direction to its naturally inclined position; and thus a staring coat usually accompanies hide binding. In considering the subject of condition (6425.), we have seen that it is not a disease of itself, but is in every instance a symptom only.

SUBJECT. 7. *Glanders and Farcy.*

6492. *The glanders* is the opprobium medicorum, for hitherto no attempts have succeeded in the cure of more than a few cases. By some peculiar anomaly in the constitution of the horse, although conclusive proofs are not wanting that this and farcy are modifications of one disease, and can each generate the other; yet the one is incurable, while the other is cured every day. When glanders has been cured, the time and labour necessary to accomplish the end has swallowed up the value of the horse; and has also, in many supposed instances of cure, left the animal liable to future attacks which have occurred. The experiments on glanders, pursued at the veterinary college and by White of Exeter, have thrown great light on the disease itself, its causes, connexions, and consequences; but have done little more. From these we are led to conclude that glanders will produce farcy, and that farcy can produce glanders; that glanders is highly infectious, and that such infection may be received by the stomach, or by the skin when it is at all abraded or sore; and it is also probable, that it is received by the noses of horses being rubbed against each other. White's experiments go to prove that the air of a glandered stable is not infectious; but this matter is by no means certain, and should not be depended on without a greater body of evidence.

6493. *The marks of glanders* are a discharge of purulent matter from ulcers situated in one or both nostrils, more often from the left than the right. This discharge soon becomes glairy, thick, and white-of-egg-like: it afterwards shows bloody streaks, and is fetid. The glands of the jaw of the affected side, called the kernels, swell from an absorption of the virus or poison; and as they exist or do not exist, or as they adhere to the bone or are detached from it, so some prognosis is vainly attempted by farriers, with regard to the disease; for in some few cases these glands are not at all affected, and in a great many they are not bound down by the affection to the jaw. As there are many diseases which excite a secretion of matter from the nose, and which is kept up a considerable time, so it is not always easy to detect glanders in its early stages. Strangles and violent colds keep up a discharge from the nostrils for weeks sometimes. In such cases a criterion may be drawn from the existence of ulceration within the nose, whenever the disease has become confirmed. These glandrous chancres are to be seen on opening the nostril a little way up the cavity, sometimes immediately opposed to the opening of the nostril; but a solitary chancre should not determine the judgment. The health often continues good, and sometimes the condition also, until hectic takes place from absorption, and the lungs participate, when death soon closes the scene.

6494. *The treatment of glanders*, it has already been stated, is so uncertain that it is hardly worth the attempt; however, when the extreme value of the horse or the love of experiment leads to it, it may be regarded as fixed by experience, that nothing but a long course of internal remedies, drawn from the mineral acids, can effect it. These have all been tried in their endless variety: White recommends the mildest preparations of mercury, as *æthiops mineral*; under the conviction that the more acrid preparations disturb the powers of the constitution so much, as to destroy as effectually as the disease. At the veterinary college the *sulphate of copper* (blue vitriol) has been long in use. Others have used the *sulphates of iron and zinc*. Clark recommends the daily administration of a drink or ball, composed of the following ingredients:—*Sulphate of zinc, 15 grains; powdered cantharides, 7 grains; powdered allspice 15 grains*; of the utility of which he gives one or two extraordinary proofs, and Mr. Sewell still attaches much importance to its use, in such daily doses as the stomach will bear. Blaine appears but little sanguine as to any medical treatment, but recommends a union of the mineral acids in the same proportions, and with the same cautions, as are detailed under farcy. (6496.)

6495. *The farcy is a disease more easily cured than the glanders*, of which our daily experience convinces us; farcy, or farcin, attacks under distinct forms, one of which affects the lymphatics of the skin, and is called the *bud or button farcy*: the other is principally confined to the hind legs, which it affects by large indurations, attended with heat and tenderness. A mere dropsical accumulation of water in the legs sometimes receives the name of *water farcy*; but this has no connection whatever with the true disease in question. Farcy is very contagious, and is gained from either the matter of farcy or from that of glanders.

6496. *Treatment of farcy.* The distended lymphatics or buds may often be traced to one sore, which was the originally inoculated part; and in these cases the destruction of this sore, and that of all the farced buds, will frequently at once cure the disease, which is here purely local. But when the disease has proceeded farther, the virus must be destroyed through the medium of the stomach; although, even in these cases, the cure is rendered more speedy and certain, by destroying all the diseased buds, by caustic or by cautery. Perhaps no mode is better than the dividing them with a sharp firing-iron; or if deeper seated, by opening each with a lancet, and touching the inner surface with *lapis infernalis*. The various mineral acids may any of them be tried as internal remedies with confidence; never losing sight of the necessity of watching their effects narrowly, and as soon as any derangement of the health appears, to desist from their use. *Oxymuriate of quicksilver* (corrosive sublimate) may be given in daily doses of fifteen grains; *oxide of arsenic* may also be given in similar doses. The *subacetate of copper* (verdigris) may also be tried, often with great advantage, in doses of a drachm daily. Blaine joins these preparations, and strongly recommends the following:—*Oxymuriate of quicksilver, oxide of arsenic, subacetate of copper, of each eight rains; sulphate of copper, one scruple*; make into a ball and give every morning, carefully watching the effects; and if it be found to occasion distress, divide, and give half, night and morning. The same author professes to have received great benefit from the use of the following:—*The expressed juice of clovers or goose-grass, a strong decoction of hempseeds, and of sassafras, of each six ounces*, to be given after the ball. It remains to say, that whatever treatment is pursued either with respect to farcy or glanders will be rendered doubly efficacious if green meat be procured, and the horse be fed wholly on it; provided the bowels will bear such food: but if the medicines gripe, by being joined with green food, add to the diet bean-meal. When green meat cannot be procured, carrots usually can; and when they cannot, still potatoes may be boiled, or the corn may be speared or malted. As a proof of the beneficial effects of green meat, a horse, so bad with farcy as to be entirely despaired of, was drawn into a field of tares, and nothing more was done to him, nor further notice taken of him, although so ill as to be unable to rise from the ground when drawn there. By the time he had eaten all the tares within his reach, he was enabled to struggle to more; finally, he rose to extend his search, and perfectly recovered.

SUBJECT. 8. *Diseases of the Extremities.*

6497. *Shoulder strains* are very rare, most of the lamenesses attributed to the shoulder belong to other parts, and particularly to the feet. Out of one hundred and twenty cases of lameness in the fore extremities, Blaine found that three only arose from ligamentary or muscular extension of the shoulder. When a shoulder strain does happen, it is commonly the consequence of some slip, by which the arm is forced violently outwards. It is less to be wondered at than at first seems probable, that farriers mistake foot lameness for shoulder strains, when we reflect that a contracted foot occasions inaction, and a disposition to favour the limb by pointing it forward, which thus wastes the muscles of the shoulder. Seeing one shoulder smaller than the other, the evil is supposed to be there, and it is pegged, blistered, and fired,

or the horse is swam for it to his torture, and the increase of the foot's contraction by the confinement. In real shoulder strains, the toe is dragged along the ground while in motion; at rest it is planted forward, but resting on the point of the toe. When the lameness is in the foot, the horse points his foot forward also, but he does so with the whole limb unbent, and the foot flat. These differences are highly necessary to attend to, as well as the peculiar difficulty which is always apparent in moving down hill, which he does with reluctance, and by swinging his leg round to avoid flexing it. This lameness may be farther brought to the test by lifting up the fore leg considerably, which, if the evil be in the shoulder, will give great pain. The muscles between the fore legs are likewise tumefied and tender in these cases.

6498. *The treatment* consists, when it is recent, in bleeding in the plate vein, rowelling in the chest, and fomenting with hot water two or three times a day. When the heat and tenderness have subsided, first bathe daily with the astringent wash for strains (*Vet. Pharm.* 6555. No. 1.) for a week; and afterwards, if necessary, proceed to blister in the usual manner.

6499. *Strain in the whirl bone.* (6324.) This important joint is sometimes strained, or its ligaments and muscles unnaturally extended, from a greater force being applied to them than their structure is able to bear, or their powers to resist: a lésion takes place of some of their fibrillæ, or in lesser injuries their elasticity is injured by being put on the stretch beyond their power of overcoming again. In all such cases, the parts react, and inflammation follows; by which heat, tenderness, and swelling ensue.

6500. *Treatment.* The first indication is the same in this as in all ligamentary strains, which is to moderate the inflammation by fomentations, &c. &c., and when that has subsided, to endeavour by astringents and bracers to restore the tone of the parts: after which, if any swelling remains, from the extravasated blood becoming organised, to promote its absorption by mercurial frictions, and blistering. This applies to all strains, and will direct the treatment therefore of that of strain in the articulation of the thigh with the body also.

6501. *Strain in the stifle,* is treated in the same manner.

6502. *Strain or clap in the back sinews.* This is generally an injury done to the sheaths of the tendons, or of the ligaments which bind them down. In very aggravated cases, it sometimes occurs that even the tendons themselves are extended beyond their capacity. The heat, swelling, and tenderness are first to be combated by fomentations, and if these be extreme, bleed also, and give a dose of physic. Next proceed to poultice with saturnine applications, until the heat and swelling are reduced: then use tonics, *astringent wash* (*Vet. Pharm.* 6555. No. 1. or 2.): bandage and exercise very carefully. If swelling remain after heat, pain, and lameness are past; or when lameness only remains, after all heat is gone, proceed to blister mildly twice. In all cases of ligamentary extension when the heat has subsided, the part may be considered as in a state of atony; and bandages judiciously applied are then proper, particularly during the day.

6503. *Rupture of the tendons and ligaments of the leg.* It is very seldom that the tendons themselves are ruptured, but the suspensory ligaments are more often so, and the evil is called breaking down. It is usually very sudden, and the fetlock is brought almost to the ground. A perfect cure is seldom obtained; but the inflammation should be moderated by the means already described, and the heels should be raised. A laced stocking or firm bandage, when the inflammation has subsided, is necessary; and firing is often prudent as a permanent bandage.

6504. *Strains of the ligaments of the fetlock and coffin joints* often occur, and may always be distinguished by the heat, tenderness, and swelling. Treat as already described. In all strains of the leg, attended with inflammation, a goulard poultice is a convenient and useful application. The goulard water should be mixed with bran; and a worsted stocking being drawn over the foot, and up the leg, it is first tied around the foot; the poultice is then put in, and the stocking fastened around the leg above the injury. (6536)

6505. *Mallenders and scellenders* are scurfy scabby eruptions, affecting the back of the knee, and ply of the hock; common only in coarse, low-bred, and in cart horses. Wash with soft soap every day, after which anoint with an unguent formed of equal parts of mercurial ointment, tar, and calamine cerate.

6506. *Broken knees.* The usual cases of broken knees are referrible to wounds in general; and the treatment of them in nowise differs therefrom, with this caution, that here it is more immediately necessary, both for appearance and safety, that if any flap of skin hang apart, to cut it off, or the wound will heal with rugosed edges. But when the joint of the knee is broken into by the violence of the injury, it becomes of a very different nature, and is known first by the extreme lameness and swelling that occur; and next, by the escape of a slippery mucus not unlike the white of an egg. If this continue to escape, violent inflammation follows, and either the horse or the joint are lost by it. Farriers are apt to attempt to stop the flow of the *joint oil*, as it is called, by oil of vitriol, or other escharotics, which treatment is usually followed by the most disastrous consequences. It is, however, necessary to stop the immediate flow, by other means; the best of which is by a fine budding-iron heated. Should the laceration be considerable, this cannot be done; but the treatment must then consist of saturnine poultices, bleeding, low diet, and the other antifebrile remedies, until the swelling has subsided, when apply the astringent paste recommended by Clark, made of pipe-clay and alum, every day; but by no means introduce any escharotics.

6507. *Splints and bone spavins.* The former are usually situated on the inner side of the canon or shank before; and as they are situated, so they are more or less injurious. When buried, as it were, within the tendons or back sinews, they are very apt to lame the horse seriously; but when situated on the plain bone, unless they be very large, they seldom do much injury. If a splint be early attended to, it is seldom difficult to remove. Blaine recommends the swelling to be rubbed night and morning for five or six days, with a drachm of mercurial ointment, rubbing it well in; after which to apply a blister, and at the end of a fortnight or three weeks to apply another. In very bad cases, he recommends firing in the lozenge form.

6508. *Bone spavin* is an exostosis of the hock bones, the treatment of which in nowise differs from that of splint; except that as a spavin in general is more injurious than a splint, so it is more necessary to commence the treatment early, and to continue it energetically. From the greater complexity of structure in the hock, spavin is not so easily removed as splint, and more usually requires the application of firing.

6509. *Ring bone* is of the same nature, being an exostosis or bony circle formed around the coronet, the treatment of which is the same with that of splint and spavin.

6510. *Blood spavin, bog spavin, and thoroughpin,* are all of them originally of the nature of windgalls, and are nothing more than enlargements of the bursal capsules described in the anatomy, as surrounding tendons, ligaments, and bones, to furnish them with a lubricating medium. By over-exertion or hard work these bursal bags become extended, and their contents increased and distended into puffy swellings in the hock, called, when on the ply, *bog spavin*. The pressure of this sometimes occasions a varicose state of the superficial vein, which passes directly over it on the inner side of the hock, and which enlargement then receives the name of *blood spavin*. When the bursal enlargement extends through the hock, it is called *thoroughpin*. When it is situated below, in the bursæ of the flexor tendons, near the fetlock joint, it receives the name of *windgall*.

6511. *The treatment* of all these cases must be similar in principle, and consists in lessening the distended sac; not as was formerly practised, to the destruction of the horse often, by letting out the contents of these windgalls; but by strengthening the sides of the tumours by stimulants or by pressure. The more active stimulants are the liquid blister (*Vet. Pharm.* 6562.), milder ones are found in the astringent wash. (*Vet. Pharm.* 6555. No. 1.) Bandages assist greatly, when well applied to the part, and in desperate cases firing has been resorted to, which is nothing more than a more violent stimulant, and a more permanent bandage.

6512. *Capulet* is a bursal enlargement of the point of the hock, and is to be treated by friction, astringents, and bandage.

6513. *Curb* is an inflammation of the ligaments at the back of the hock, and is usually removed by astringents. (*Vet. Pharm.* 6555.) When it does not give way to these, the sweating liquid blister may be applied. (*Vet. Pharm.* 6563.)

6514. *Cracks and grease* may be considered as modifications of one and the same affection, and are commonly brought on by some neglect in all horses; but when they occur in any but the thick-heeled low-bred animals, they are invariably so. Over-feeding or under-feeding, but much more frequently the former, will bring it on. A very frequent cause of it is the practice of washing the legs of horses, and suffering them to dry of themselves. In every case, without exception, washing the legs should be avoided, unless they be rubbed perfectly dry afterwards. When horses have long hairs about their heels, and are washed and then left wet, the evil must be doubled; as the evaporation going on, cools and chills the heels, and thus produces a species of chilblain: and we well know how difficult these are to heal when broken. Cracks in the heels very often occur in horses removed too suddenly into full keep from previous straw or grass, or from these to a hot stable; which, by the heat and moisture of the litter, occasions a determination of blood and humours to the legs, and they break out into cracks or scabs, from which issue a bloody ichor, or a more thick matter. Between the sores the hair stares and gets pen-feathered, and the horse finds difficulty and pain in moving.

6515. *The treatment* must depend on the state in which the animal is at present. If there be reason to suspect the horse to be full and foul, bleed, lower his food, soil him in the stable; or mash and give a mild dose of physic. But when some mismanagement is the sole cause, remove that, and if the case be a severe one, by means of an old stocking drawn over the foot, bury the whole heel in a poultice, made of scraped carrots or turnips; which will subdue the irritation, and bring the parts into a state to bear the application of the astringent paste (*Vet. Pharm.* 6557. No. 2.), or if more convenient, of the astringent wash. (*Vet. Pharm.* 6555. No. 1. or 2.) Moderate exercise should be continued, and the heels carefully cleaned from dirt by soft soap and water on each return therefrom; after which, always again apply the astringent.

6516. *Grease* is nothing more than an aggravated state of the same affection, and is more common to the hind than to the fore legs. Coarse fleshy-legged horses are peculiarly prone to the affection, from the great accumulation that takes place in their legs; and from the difficulty that the capillaries find in carrying the increased quantity of lymph upwards. In these, long stable confinement should be avoided, and when that is impossible, it should be counteracted by exercise frequently and judiciously administered. Many cart horses never go out but to work: they often work three days incessantly, or nearly so; and they perhaps rest two days entirely. Can it be wondered at, that the change occasions swelling, acting on the weakness and exhaustion of previous fatigue? and could not this be avoided by turning out for an hour, or walking for half an hour night and morning? Stable soiling should be used; bleeding and physicking also in very bad cases; and when the inflammation and irritation or soreness are great, the poultices recommended for cracks should be applied until these circumstances are removed: afterwards commence the use of some of the astringents recommended. (*Vet. Pharm.* 6555.) White has stated two remarkable cases of grease cured by the application of corrosive sublimate, in the form of a wash, as of *two drachms of sublimate to ten ounces of water*; increasing it to three drachms, if the pain occasioned by the first be not too considerable. Blaine says that the clivers or goose-grass has been known to be of great service in bad cases of grease: half a pint of the expressed juice to be given daily as a drink; and a poultice of the herb to be applied to the heels. In some cases of long standing when the running has ceased, a thickened state of the limb remains, which is best removed by firing, and which likewise is a preventive to a return.

SUBJECT. 9. Diseases of the Feet.

6517. *Founder of the feet is of two kinds, acute and chronic. Acute founder* is a disease that, until lately, was less understood than almost any other. After a very severe day's work, or when very much heated, if a horse get a sudden chill by standing in snow or cold water, it is not uncommon for him to be seized with universal stiffness and every symptom of great fever. Such a horse is said to be *body foundered*. By degrees, however, it is observed that the animal has an extreme disinclination to remain on his feet; from whence it will appear that the whole of them are affected. When the horse draws his hind feet under him, his fore only are affected: and when he draws his fore feet under him, the hinder feet are the seat of the complaint; but which is seldom the case. On feeling the feet they will be found intensely hot, and the pastern arteries will beat with great violence. After a few days, unless the disease abate, a separation of the hoofs from the coronet takes place, and at last they fall entirely off.

6518. *The treatment.* At the commencement of the disease bleed largely, as well by the neck as from the toe of each affected foot, by paring, until the blood flows freely. After which immerse each foot in a goulard poultice (6536.), give the fever powder or drink (*Vet. Pharm.* 6578 and 6579.), litter up to the belly; and if amendment do not take place, renew the bleedings, and blister round the pasterns.

6519. *Chronic founder, contraction or fever in the feet.* The artificial life that horses lead subjects them to many diseases; one of the principal of which is that of contracted feet. Blaine considers a neglect of sufficient paring of hoof, the application of artificial heat from hot stables, and hotter litter, the deprivation of natural moisture, constitutional liability, and the existence of thrushes, as among the principal causes of this evil. It is more common to blood horses than to others; and he observes, that dark chestnuts are of all others most prone to it. The appearances of a contracted foot, as contrasted with a healthy one, we have already displayed. (6420.) It is there shown that the contracted hoof becomes longer, higher, and narrower: the heels (*fig. 837. a a*) particularly are drawn in, and seem to screw the frog between them, which becomes wasted and thrushy from this pressure. The hinder hoofs are seldom affected.

6520. *The treatment of contraction in the feet.* It is better to prevent, than to be under the necessity of attempting to cure, the evil. Prevention may be practised by avoiding the acting causes. As soon as at all suspected to be likely to occur, keep the hoofs pared low; never suffer the horse to stand on litter, nor allow the stable to be too hot; feed moderately, and never allow the horse to go without daily exercise; whatever increases the general fulness of habit, flies to the feet. Above all, keep the feet moist by means of wet cloths tied loosely around the coronet, falling over the whole hoof, but not extending beyond the edge. Then moisten repeatedly, and stop the feet (6587.) every night. When contraction has already taken place, many plans have been recommended; as jointed shoes by Coleman, Clark, and others; but it is not found that mechanical expansion in this way produces permanent benefit. The most effectual mode is to obviate all previous causes of contraction; and then to thin the hoofs around the heels from each quarter so thin as to be able to produce an impression by means of the thumb: in fact, to remove so much of the horn as is consistent with safety, from the coronet downwards. It is also prudent to put in a score or two from above downwards, drawn a quarter of an inch deep on each side towards the front of the hoof; but whether this be done or not, the front of the hoof should be rasped thin about an inch in width; by which means a hinge is formed, which operates most advantageously in opening the heels. After this is done, tips should be put on, and the horse should be turned out to grass, where he should remain three months, by which time the new formed heels will have reached the ground, and will bear a shoe. This process is fully described by Blaine in his *Veterinary Outlines*, where a plate completely elucidates the operation, and to which we would recommend the reader.

6521. *The pumiced foot* is a very common consequence of acute founder, in which the elasticity of the laminae becoming destroyed, the support of the coffin bone is removed, and it rests wholly on the sole,

which it gradually sinks from a concave to a convex surface, drawing with it the front of the hoof inwards. In weak, broad, heavy feet, this evil comes on sometimes without founder; the treatment can be only palliative, a wide-webbed shoe exactly fitted to the foot, without at all pressing on it, prevents the lameness consequent to the disease. A shoe exactly the contrary to this has been tried in some cases with benefit, the form of which has been one with a web so narrow as only to cover the crust, but so thick as to remove the feet from accidental pressure. In other cases, no shoe answers so well as a strong bar shoe. (6601)

6522. *Corns* are most troublesome ailments, to which horses are very liable, and which injure and ruin thousands. They are wholly accidental; no horse having any peculiar tendency to them, but being always brought on them by some improper pressure, usually of the shoe, or from something getting in between the shoe and the horny heel. A shoe too long worn is a very common cause, and a still more frequent one is the clubbing the heels of the shoe; neither is it necessary to the production of corns, that the shoe itself should press on the sole; but they are equally produced when the outer horn of the heels or of the bars is the immediate offending part, rendered so by too luxuriant growth, by unequal wear, or by secondary pressure from the shoe, or by gravel working in. (*fig.* 836.) It is the fleshy sole itself that is bruised, from which a speck of extravasated blood follows; and if not immediately relieved, it gathers, or the part becomes habitually defective, and instead of forming healthy horn, it always afterwards forms a spongy substance of extreme sensibility, and thus is always liable to produce pain and lameness when exposed to pressure.

6523. *The treatment of corns* is seldom difficult or unsuccessful at their first appearance, but afterwards it can be only palliative. Blaine directs that, by means of a fine drawing-knife, every portion of diseased horn should be pared away, and the extravasation underneath likewise. Having done this, he advises to introduce some *butter of antimony* into the opening, to place over this some tow, which should be kept in its place by means of a splint. If any contraction of the heels (*fig.* 836. *a a*) be present, it will materially assist the cure to lower them, and to thin the hoof a little around the quarters, and afterwards to put on a shoe without heels opposed to the corn, or a shoe chambered opposite the weak part; or a bar shoe may be applied, so framed as completely to leave the heel untouched. Introduce the butter of antimony once or twice more, with the interval of two days between, and then turn the horse out to grass: in about six weeks' time the foot will be sound. The treatment of corns, when of long standing, does not materially differ; for although they are never wholly eradicated, they may be rendered but little troublesome. The diseased part must be carefully pared out at each shoeing, and such a shoe put on as will completely free the heel from pressure.

6524. *Running thrush* is always a dangerous disease, and few errors in horse management are more glaring than the common one of supposing they are necessary to carry off humours. If less food, more exercise, cool stables, and dry standings, were substituted to correct the fulness, instead of thrushes, which invariably contract the feet whenever they continue any length of time, many valuable horses would be saved to the community. To the cure, begin by clearing out all the fissures of the frog (*fig.* 836. *a a*) from loose ragged horn, and then introduce to the bottom of the sinuses, by means of a thin piece of wood, some of the *thrush paste* (*Vet. Pharm.* 6554.), smeared on tow, which will enable it to be held within the cleft, especially if it be guarded by splints of wood passed under the shoe; renew the dressing daily: turning out to grass may be practised to great advantage for thrushes by this mode of dressing; but without it the disease is sometimes aggravated.

6525. *Sandcracks* are fissures in the hoofs, commonly of those before, and usually towards the inner, but now and then towards the outer quarter also, from above downwards: from the crack, a little oozing of blood or moisture is seen; and the sensible parts underneath getting between the edges of horn, become pressed on and lame the horse. Fire the fissure crossways, so as to destroy the connection between the divided and the undivided parts of the hoof. With melted pitch close up the origin if the oozing be moderate, and bandage tightly. Watch the foot, and if inflammation succeed this plan, remove the dressing.

6526. *Pricks or punctures in the feet* are often very serious evils, either when received by nails in shoeing, or by one picked up on the road, &c. The danger arises from the inflammation, which is always great from any injury done to the sensible and vascular parts within the foot. This inflammation quickly proceeds to suppuration; and the matter is apt to make its way upwards, unless it find a ready vent below. When it does not break out at the coronet, it will often penetrate under the sole, and finally disease the bones, ligaments, or cartilages, and produce quittor. It is very seldom that a horse is pricked in shoeing, but that the smith is aware of it by the peculiarity of the feel on the hammer, and by the finching of the animal. At such times were he to immediately withdraw the nail a little, enlarge the opening, and introduce some spirit within the puncture, nothing would occur; but on the contrary, he sends the horse home to avoid trouble, who, the next or following day, is found lame, and with his foot hot. If the nail be only driven too near the sensible laminae, it will only require to be removed, to free the horse from his evil; but if it have been driven through, and have wounded them, then suppuration ensues, and on examining the foot by the pincers when the shoe is removed, he will finch at the pressure on the diseased part. It is probable, on the removal of the shoe, that matter will at once flow out at the immediate nail hole; if not, the drawing-knife will soon detect the injury. If the heat be great, and instead of matter bloody dark ichor flows out, wrap the foot up in a poultice; but if healthy matter flows out, this will not be necessary: sometimes it is requisite to detach all the horn that is underrun by the matter; but when the injury has not proceeded to this extent, apply over the part a pledget of tow steeped in friar's balsam; tack on the shoe lightly, and retain the dressing by means of *splints*, which are thin pieces of wood (the withy which binds birch brooms is convenient for the purpose) passed under the shoe; repeat the dressing daily, and avoid moisture, which would encourage quittor. A nail picked up on the road, and which passes through the sole, below or through the frog, is to be treated in the same manner, and also when the matter breaks out at the coronet; but when a nail is picked up, and penetrates the coffin joint, which is known by the synovia or joint oil appearing, such opening should be immediately stopped by paring towards the wounded joint, and then applying a heated budding-iron, not to the capsular ligament itself, but to the skin immediately near it; if this be inconvenient, put a pledget dipped in a little butter of antimony just within the opening, but do not press it into the cavity of the joint: if this be insufficient to stop the flow, but more particularly if the original wound penetrated to the bone, it is probable that the bone itself will become, in some measure, diseased, which is known by the rough grating felt at the point of the probe when passed. In this case, enlarge the opening so as to be able to scrape the diseased bone away. *Bruises of the sole*, from whatever cause, will all fall under some of these points of view, according as the case may be.

6527. *Quittor and canker* are the consequences of these injuries when neglected, or originally extensive. In these cases either the bones, ligaments, or cartilages, or all, become diseased; and a cure can only be obtained by removing the diseased parts by the knife or by caustic.

6528. *Treads, over-reach, &c.* A wound on the coronet is not uncommon from one foot being placed on the other; or the hinder foot may strike it, &c. First wipe away the dirt, and remove any loose edges that cannot unite: avoid washing, unless stones and dirt are suspected to be within, and bind up, having first placed over the wound a pledget of lint or tow moistened with balsamic tincture, or tincture of myrrh, or of aloe, &c. *Over-reaching, or over-stepping*, is often an injury done to the fetlock joint before, by the hinder foot, or to the back sinew higher up. Sometimes it is simply a violent bruise, at others the laceration is extensive, in which cases treat as a tread; and when no laceration has taken place treat as a bruise or strain.

6529. *Cutting* is a defect to which some horses are liable from their form, as when they turn their toes

out, or have bent legs. Others cut only when they are lean, which brings their legs nearer together. Weak horses cut because they cross their legs when fatigued, and young unfurnished horses cut at youthful periods, and grow out of it afterwards. The part in which a foot interferes with the opposed limb is very different. When it strikes the shank high up it is called *speedy cut*, and is best remedied by wearing knee-boots or rollers. When it is at the fetlock the cutting is at the side, or rather backward, according to circumstances. Some horses cut by the edge of the shoe, others by the hoof at the quarters; and some by the point of the heels. It is to be remarked, that it is better to put up with the evil of cutting, than to do as is too frequently done, which is, to pare away the hoof until it excites contraction. The shoe may be feather edged, or it may be set a little within the cutting quarter; but by no means alter the size or the form of the hoof's themselves, and particularly avoid taking liberties of this kind with the fore feet. Boots, or rollers, are but little trouble to put on, and when not buckled too tight never injure: whereas, to allow a horse to continue to cut produces a callus, and often throws the animal down.

SECT. VI. *Veterinary Operations.*

6530. *The general practices* to be here enumerated are chiefly the treatment of wounds, the application of fomentations, setons, blisters, clysters, and physicking; and the operations of castrating, nicking, bleeding, &c.

SUBJECT. 1. *Treatment of Wounds.*

6531. *A wound* must be treated, in some measure, according to the part of the horse's body in which it happens; but there are some principles to be observed alike in all horse surgery. There are likewise a few, which, as they differ from the principles of human surgery, should be first noticed, and which should guide the practice of those who might be misled by analogy. The wounds of horses, however carefully brought together and confined in their situation, as well as shut out from the stimulus of the external air, are seldom disposed to unite at once, or, as it is called in surgical language, by the *first intention*. It is always, therefore, necessary to expect the suppurative process: but as the adhesive inflammation does now and then occur, we should never wash a mere laceration with water or other liquids, if no foreign matter, as dirt, &c., be suspected to be lodged within it, still less should we stuff it with candle tow, or tents of any kind. On the contrary, it should be carefully and smoothly brought together, and simply bound up in its own blood; and if it do not wholly unite at once, and by the *first intention*, perhaps some portion of it may; and, at all events, its future progress will be more natural, and the disfiguration less than when stuffed with tents, tow, &c., or irritated with heating oils or spirits. When an extensively lacerated wound takes place, it is common, and it is often necessary to insert sutures, or stitches, into the lips of the wound: and here we have to notice another considerable variation from the principles of human inflammation, which is, that these stitches in the horse, ox, and dog, soon ulcerate out, seldom remaining longer than the third or fourth day at farthest. It therefore is the more necessary to be careful, that by perfect rest, and the appropriation of good bandages, we secure the wound from distortion. In this we may be assisted by strips of sticking plaster, made with diachylon and pitch; but these strips should be guarded from touching the wound itself by means of lint or tow first put over it. When, in addition to laceration in a wound, there is a destruction of substance, then the caution of washing will not apply, as it will be necessary to bathe with some warming spirit, as *tincture of myrrh*, *tincture of aloes*, or *friar's balsam*, to assist in restoring the life of the part, and in preventing mortification. Bleeding must be stopped by pressure and astringents, as powdered alum: when it is very considerable, the vessel from whence the blood comes must be taken up. When great inflammation follows wounds or bruises, counteract it by bleeding, a cooling temperature, opening medicines, and continual fomentations to the part itself.

SUBJECT. 2. *Balls and Drinks.*

6532. *Mode of giving a ball.* Back the horse in his stall, and being elevated on a stool (not a bucket turned upside down), gently draw the tongue a little out of the mouth, so as to prevent its rising to resist the passage of the hand; the tongue should however not be laid hold of alone, but it should be held firmly by the fingers of the left hand against the jaw. The ball previously oiled, being taken into the right hand, which should be squeezed into as narrow a shape as possible, must be passed up close to the roof of the mouth, and the ball placed on the root of the tongue, when both hands being withdrawn, it will readily pass down. This mode is much preferable, when a person is at all handy, to using a balling iron. At Long's, veterinary surgeon's instrument maker, is sold a clever machine for this purpose.

6533. *Mode of giving a drink.* Exactly the same process is pursued, except that a horn holding the liquid matter is forced up the mouth; the passage being raised beyond the level line, the liquid is poured out from the larger end of the horn, and when the tongue is loosened it is swallowed. Clark, however, ingeniously proposes to substitute the smaller end of the horn, the larger being closed, by which, he says, the horn can be forced up the mouth between the teeth, and poured farther back so as to ensure its not returning.

SUBJECT. 3. *Fomentations and Poultices.*

6534. *Fomentations* are very commonly recommended of various herbs, as rue, chamomile, St. John's wort, wormwood, bay leaves, &c.; but the principal virtue is to be found in warmth and moisture, which unload the vessels: but this warmth ought not to be too considerable, except when the inflammation is within, as in inflamed bowels. Here we foment to stimulate the skin, and cannot foment too hot: but when we do it at once to an inflamed part, it ought not to be more than of blood heat; and it should be continued long, and when removed the part should be dried or covered, or cold may be taken, and the inflammation increased instead of diminished. *Anodyne fomentations* are made of poppy heads, and of tobacco, and are frequently of great use.

6535. *The method of applying fomentations* is conveniently done by means of two large woollen cloths wrung out of the heated liquors; as one is cooling the other should be ready to be applied.

6536. *Poultices* act in the same way as fomentations in allaying irritation and inflammation; but are in some respects more convenient, because they act continually. It is an error to suppose that poultices, to be beneficial, should be very hot: however hot they may be applied, they soon become of the temperature of the surrounding parts. When poultices are applied to the extremities, a stocking, as has been before stated, is a convenient method of application. When it is drawn over the leg and bound around the lower part of the hoof, or of the pastern, or otherwise, the matter of the poultice may be put within, and it may be then kept in its situation, if high up on the extremity, by means of tape fastened to one part of it, and passed over the withers or back to the other side, and again fastened to the stocking. In this way, also, loose bandages may be retained from slipping down. *Cold poultices* are often useful in the inflammations arising from strains, &c. In these cases bran and goulard water form a convenient medium; but when the poultice is necessarily hot, a little linseed meal added to the bran will render it adhesive, and give it consistence. It is a very necessary caution in this, as in every instance where bandages are wanted around the extremities, to have them broad, and only so tight as to secure the matters contained, as in a poultice, or as in common bandaging.

SUBJECT. 4. *Setons and Rowels.*

6537. *Setons* are often useful in keeping up a drain to draw what are termed humours from parts ; or by their irritations on one part, they lessen the inflammation in another part not very remote, as when applied in the cheek for ophthalmia or inflamed eyes. They also in the same way lessen old swellings by exciting absorption. Another useful action they have is to make a dependent or convenient orifice for the escape of lodged matter : thus a seton passed from the upper part of the opening of pole evil, through the upper part of the integuments of the neck, as low as the sinuses run, will often effect a cure without farther application. The same with fistulous withers, which sometimes run under the shoulder blade, and appear at the arm point ; in which cases a blunt seton needle, of sufficient length to be passed down to that point, and to be then cut down upon, will form the only efficient mode of treatment. Setons may be passed in domestic farriery with a common packing needle and a skein of thread, or piece of tape ; but in professional farriery they are made by a proper needle armed with tape or lamp cotton, or skeins of thread or silk smeared over with digestive ointment. When the seton needle is removed, the ends of the tape should be joined together, or otherwise knotted, to prevent them from coming out.

6538. *Rowels* in their intention act as setons, and as irritating a larger surface, so when a general drain is required they act better ; as in grease, &c. : but when their action is confined to a part only, setons are more convenient. Any person may apply a rowel by making an incision in the loose skin about an inch, separating with the finger its adherences around, and then inserting in the opening a piece of round leather with a hole in the middle smeared with a blistering ointment. Then plug the opening with tow ; and in three days, when the suppuration has begun, remove it. The rowel leather is afterwards to be daily moved and cleaned.

SUBJECT. 5. *Blistering and Firing.*

6539. *Blistering* answers the same purpose as setons ; and is practised by first cutting or shaving the hair from the part, when the blistering ointment (*Vet. Pharm.* 6559.) should be well rubbed in for ten minutes, or a quarter of an hour. Some of the ointment after the rubbing may be smeared over the part. The head of the horse should now be tied up to prevent his gnawing or licking. If a neck eradle be at hand, it may also for safety be put on ; in which case the head may be let down the third day.

6540. *A neck cradle for blistered horses* is very convenient for other occasions also, when the mouth is to be kept from licking or biting other parts ; or to keep other parts from being rubbed against the head. It is of very simple construction, and may be made by a dozen pieces of wood of about an inch and half in diameter, as old broom handles, &c. These bored at each end admit a rope to be passed through ; and as each is passed on, a knot may be tied to the upper part of the pieces of the eradle, two inches apart ; and those which form the lower part, four inches : by which means the neck will be fitted by the eradle when it is put on ; and the horse will be prevented from bending his head to lick or gnaw parts to be protected. When the lower parts of the legs, particularly of the hinder, require blistering, it is necessary to bear in mind that in gross full horses, particularly in autumn, grease is very apt to follow blistering ; and almost certainly if the back of the heels below the fetlock be blistered. First, therefore, smear this part over with lard or suet ; and afterwards avoid touching it with the ointment. After blistering in summer, the horse is often turned out before the blistered parts are quite sound ; in this case guard them from flies by some kind of covering, or they may become fly-blown : and likewise the fourth or fifth day rub into the blistered part some oil or lard to prevent the skin from cracking.

6541. *Sweating or liquid blisters* (*Vet. Pharm.* 6563.) are only more gentle stimulants, which are daily applied to produce the same effects on a diseased part without removing the hair. Of course less activity is expected ; yet as the action is repeated, they are often more beneficial even than blistering itself : as in old strains and stiffnesses.

6542. *Firing*, as requiring the assistance of an experienced practitioner, we shall not describe ; it will be only prudent to point out that it is a more active mode of blistering ; and that it acts very powerfully as a stimulant, not only while its effects last as blisters do, but also after its escharotic effect is over, by its pressure ; and in this way it is that it operates so favourably in bony exostosis, as splints and spavins ; and in this way it is so useful in old ligamentary weaknesses ; because by lessening the dilatibility of the skin it becomes a continual bandage to the part.

SUBJECT. 6. *Clystering and Physicking.*

6543. *Clystering* should always be preceded by *back-raking*, which consists in oiling one hand and arm, and passing them up the fundament, and by that means to remove all the dung balls that can be reached. The large pewter syringe for clystering is neither a useful nor safe machine. A much better consists in a turned box pipe, to which may be attached a large pig or ox-bladder, by which four or five quarts of liquid can be administered at one time. (*Vet. Pharm.* 6564. to 6567.) The pipe should be previously oiled, by which means it passes more easily : the liquor should then be steadily pressed up ; and when the pipe is removed, the tail should be held down over the fundament a little to prevent the return of the clyster. In some cases of a spasmodic nature, as gripes and locked jaw, great force is made by the bowels to return the clyster, and nothing but continued pressure over the fundament can enable it to be retained. *Clysters* not only act in relaxing the bowels, but they may be used as means of nutriment when it cannot be taken by the mouth ; as in locked jaw, wounds of the mouth, throat, &c. &c. In locked jaw, it was observed by Gibson, that he kept a horse alive many days by clysters alone : and by clysters also many medicines may be given more conveniently than by the mouth.

6544. *Physicking of horses.* It is equally an error to refrain altogether from giving horses physic, as it is to give it on every occasion, as some do. Neither is it necessary for horses to be bled and physicked every spring and autumn, if they be in perfect health, and the less so, as at this time they are generally weak and faint from the change going on in their coats. Nor is it always necessary to give horses physic when they come from grass or a straw yard ; provided the change from the one state to the other be very moderately brought about. But on such a removal, it certainly expedites all the phenomena of condition (6423.), and such horses are less likely to afterwards *fall to pieces*, as it is termed. (6424.) In various morbid states physic is particularly useful, as in worms, hide-bound from too full a habit, &c. &c. It is not advisable to physic horses in either very cold or very warm weather. Strong physic is always hurtful : all that physic can do is as well operated by a mild as by a strong dose, and with infinitely less hazard. No horse should be physicked whose bowels have not been previously prepared by mashing for two days at least before. By these means the physic will work kindly, and a moderate quantity only is requisite. Most of the articles put into the purging balls for horses, to assist the aloes, are useless. Jalap will not purge a horse, nor rhubarb either. Aloes are the only proper drug to be depended on for this purpose, and of all the varieties of aloes the socotorine and Cape are the best. (*Vet. Pharm.* 6584.) Barbadoes aloes are also not improper, but are thought more rough than the socotorine. For formulæ of purging balls, see *Vet. Pharm.* 6584. Blaine gives the following as the process : —

6545. *Physicking process.* The horse having fasted an hour or two in the morning from food, but having had his water as usual, give him his purge, and two hours after offer him a little chilled but not warm water, as is often done, by which horses are disgusted from taking any : it may be here remarked that in this particular much error is frequently committed. Many horses will drink water with the chill taken off, provided it be perfectly clean, and do not smell of smoke from the fire, kettle, or saucepan : but few, very few, will drink warm or hot water ; and still fewer, if it be in the least degree greasy or smoky.

After the ball has been given two hours, a warm bran mash may be offered, and a very little hay. He should have walking exercise as usual, moderate clothing, and altogether he should be kept rather more warm than usual. At noon mash again, and give a little hay, which should be repeated at night, giving him at intervals chilled water. On the following morning the physic may be expected to work; which if it do briskly, keep the horse quiet: but should it not move his bowels, or only relax them, walk him quietly half an hour, which will probably have the desired effect. Continue to give mashes and warm water, repeating them every two or three hours to support him. When physic gripes a horse, give him a clyster of warm water, and hand-rub the belly, as well as walk him out. If the griping prove severe, give him four ounces of gin in half a pint of sound ale, which will soon relieve him. On the next day the physic will probably set, but should it continue to work him severely, pour down some boiled starch; and if this fail, turn to the directions under diarrhœa. (6473.) The horse should return to his usual habits of full feeding and full exercise by degrees; and if more than one dose be to be given, a week should intervene. It is often requisite to make the second and third doses rather stronger than the first. A very mild dose of physic is likewise often given to horses while at grass in very warm weather, and without any injury. When worms or skin foulness are present, and mercurial physic is deemed necessary, it is better to give two drachms of calomel in a mash the previous night, than to put it into the purging ball.

SUBJECT. 7. *Castration, Nicking, Docking, &c.*

6546. *The operations of castration, docking, nicking, and that of cropping* (which is now seldom practised), all require the assistance of a veterinary surgeon; and it is only necessary to remark of them, that the after treatment must be the same as in all other wounds. To avoid irritation, to preserve a cool temperature and a moderate diet; and if active febrile symptoms make their appearance, to obviate them by bleeding, &c. &c. It likewise is proper to direct the attention of the agriculturist who attends to these matters himself, that the moment the wound following any of these operations looks otherwise than healthy, locked jaw is to be feared, and no time should be lost in seeking the best assistance that can be obtained. (6432.)

SUBJECT. 8. *Bleeding.*

6547. *Bleeding* is a very common, and to the horse a very important operation, because his inflammatory diseases, on account of the great strength of his arterial system, run to a fatal termination very soon, and can only be checked in the rapidity of their progress by abstracting blood, which diminishes the momentum of circulation. Bleeding is more particularly important in the inflammatory diseases of the horse; because we cannot, as in the human frame, lower the circulation by readily nauseating the stomach. Bleeding also lessens irritation particularly in the young and plethoric, or those of full habit: hence we bleed in spasms of the bowels, in locked jaw, &c., with good effect. Bleeding is general or topical. *General*, as from the neck, when we mean to lessen the general momentum. *Topical*, when we bleed from a particular part, as the eye, the plate vein, the toe, &c. Most expert practitioners use a large lancet to bleed with; and when the habit of using it is acquired, it is by far the best instrument, particularly for superficial veins where a blow might carry the fleam through the vessel. In common hands the fleam (*fig. 838.*), as the more general instrument, is best adapted to the usual cases requiring the agriculturist's notice. Care should, however, be taken not to strike it with vehemence; and the hair being first wetted and smoothed down, it should be pressed close between the hairs, so that its progress may not be impeded by them. A ligature should be first passed round the neck, and a hand held over the eye, unless the operator be very expert, when the use of the fingers will dispense with the ligature. The quantity of blood taken is usually too small. In inflammatory diseases, a large horse, parti-

838



cularly in the early stage of a complaint, will bear to lose eight or ten quarts: and half the quantity may be taken away two or three times afterwards, if the violence of the symptoms seem to require it; and the blood should be drawn in a large stream to do all the good it is capable of. After the bleeding is finished, introduce a sharp pin, and avoid drawing the skin away from the vein while pinning, which lets the blood escape between the vein and skin: wrap round a piece of tow or hemp, and next day remove the pin, which might otherwise inflame the neck. In drawing blood, let it always be measured: letting it fall on the ground prevents the ascertaining the quantity; it also prevents any observation on the state of the blood, which if it form itself into a cup-like cavity on its surface, and exhibit a tough yellow crust over this cavity, it betokens an inflammatory state of body that will require further bleedings, unless the weakness forbid. After the bleeding, it now and then happens, from rusty lancets, too violent a stroke with the blood stick, or from drawing away the skin too much while pinning up, that the orifice inflames and hardens, and ichor is seen to ooze out between its edges. Immediately this is discovered, recourse must be had to an able veterinary surgeon, or the horse will lose the vein, and perhaps his life.

SECT. VII. *Veterinary Pharmacopœia.*

6548. *The following formulæ for veterinary practice* have been compiled from the works of the most eminent veterinary writers of the present day, as Blaine, Clark, Laurence, Peel, White, &c.; and we can, from our own experience also, confidently recommend the selection to the notice of agriculturists, and the owners of horses in general. It would be prudent for such as have many horses, and particularly for such as live at a distance from the assistance of an able veterinarian, to keep the more necessary articles by them in case of emergence: some venders of horse drugs keep veterinary medicine chests; and where the compositions can be depended on, and the un-compounded drugs are genuine and good, one of these is a most convenient appendage to every stable. The best arranged veterinary medicine chest we have seen was in London, at the veterinary laboratory of Youatt of Nassau Street, Middlesex Hospital.

6549. *The veterinary pharmacopœia for oxen, calves, and sheep* has been included in the arrangement. When any speciality occurs, or where distinct recipes are requisite, they have been carefully noticed; it will therefore only be necessary to be kept in mind, that with the exception of acrid substances, as mineral acids, &c., which no cattle bear with equal impunity with the horse, the remedies prescribed require about the following proportions:—A large ox will bear the proportions of a moderate-sized horse; a moderate-sized cow something less; a calf about a third of the quantity; and a sheep about a quarter, or at most a third of the proportions directed for the cow. It is also to be remarked, that the degrees in strength in the different recipes are usually regulated by their numbers, the mildest standing first.

6550. *Alteratives.*

1. Levigated antimony, 2 drachms.
Cream of tartar,
Flower of sulphur, each half an ounce.
2. Cream of tartar,
Nitre, of each half an ounce.

3.

- Æthiops mineral,
Levigated antimony,
Powdered resin, each 3 drachms.
Give in a mash, or in corn and bran a little wetted, every night, or make into a ball with honey.

6551. *Tonic Alteratives.*

1.

- Gentian,
Aloes,
Ginger,
Blue vitriol, in powder, of each 1 drachm.
Oak bark in powder, 6 drachms.

2.
Winter's bark, in powder, 3 drachms.
Green vitriol, do., one and a half drachm.
Gentian, do., 3 drachms.

Make either of these into a ball with honey, and give every morning.

3.
White vitriol, 1 drachm.
Ginger or pimento ground, 2 drachms.
Powdered quassia, half an ounce.
Ale, 8 ounces.— Mix, and give as a drink.

4.
Arsenic, 10 grains.
Oatmeal, 1 ounce.

Mix and give in mash or moistened corn nightly.

6552. *Astringent Mixtures for Diarrhœa, Lax, or Scouring.*

1.
Powdered ipecacuanha, 1 drachm.
Do., opium, half a drachm.
Prepared chalk, 2 ounces.
Boiled starch, 1 pint.

2.
Suet, 4 ounces; boiled in Milk, 8 ounces.
Boiled starch, 6 ounces.
Powdered alum, 1 drachm.

3.
The following has been very strongly recommended in some cases, for the lax of horses and cattle:—
Glauber's salts, 2 ounces.
Epsom do., 1 ounce.
Green vitriol, 4 grains.
Gruel, half a pint.

4.
When the lax or scouring at all approaches to dysentery or molten grease, the following drink should be first given:—
Castor oil, 4 ounces.

Glauber's salts (dissolved), 2 ounces.
Powdered rhubarb, half a drachm.
Powdered opium, 4 grains.
Gruel, 1 pint.

6553. *Astringent Balls for Diabetes or Pissing Evil.*

Catechu (Japan earth), half an ounce.
Alum powdered, half a drachm.
Sugar of lead, 10 grains.
Conserve of roses to make a ball.

6554. *Astringent Paste for Thrush, Foot-rot, Foul in the Foot, &c.*

Prepared calamine,
Verdigris, of each half an ounce.
White vitriol,
Alum, of each half a drachm.
Tar, 3 ounces: mix.

6555. *Astringent Washes for Cracks in the Heels, Wounds, Sprains, &c.*

1.
Sugar of lead, 2 drachms.
White vitriol, 1 drachm.
Strong infusion of oak or elm bark, 1 pint: mix.

2.
Green vitriol, 1 drachm.
Infusion of galls, half a pint.
Mix, and wash the parts three times a day.

6556. *Powder for Cracks, &c.*

3.
Prepared calamine, 1 ounce.
Fuller's earth, powdered,
Pipe clay, do., of each 2 ounces.
Mix, and put within gauze and dab the moist surfaces of the sores frequently.

6557. *Astringent Paste for Grease.*

1.
Prepared calamine,
Tutty powdered,
Charcoal, do. of each 2 ounces.
Yeast enough to make a paste.

2.
To the above, if more strength be required, add of alum and verdigris each a drachm.

6558. *Astringent Wash for Do.*

3.
Corrosive sublimate, 2 drachms.
Spirit of wine or brandy, 1 ounce.
Soft water, 10 ounces.

Rub the sublimate in a mortar with the spirit till dissolved, then add the water. This is a strong preparation, and has often proved successful in very bad cases of grease, which have resisted all the usual remedies.

6559. *Blisters.*

1. A general one.
Cantharides powdered, 2 ounces.
Venice turpentine, do.
Resin, do.
Palm oil or lard, 2 lbs.

Melt the three latter articles together, and when not too hot stir in the Spanish flies.

2.
6560. *A strong cheap Blister, but not proper to be used in Fevers or Inflammations, as of the Lungs, Bowels, &c.*

Euphorbium powdered, 1 ounce.
Oil of vitriol, 2 scruples.
Spanish flies, 6 ounces.
Palm oil or lard,
Resin, of each 1 lb.
Oil of turpentine, 3 ounces.

Melt the resin with the lard or palm oil. Having previously mixed the oil of vitriol with an ounce of water gradually, as gradually add this mixture to the melted mass; which again set on a very slow fire for ten minutes more: afterwards remove the whole, and when beginning to cool, add the powders previously mixed together.

3.
6561. *A mercurial Blister for Splints, Spavins, and Ringbones.*

Of either of the above, 4 ounces.
Corrosive sublimate, finely powdered, half a drachm.

4.
6562. *Strong Liquid Blister.*

Spanish flies in gross powder, 1 ounce.
Oil of origanum, 2 drachms.
Oil of turpentine, 4 ounces.
Olive oil, 2 ounces.
Steep the flies in the turpentine three weeks, strain off, and add the oil.

5.
6563. *Mild Liquid or Sweating Blister.*

Of the above, 1 ounce.
Olive oil or goose grease, one and a half ounce.

6564. *Clysters, a Laxative one.*

1.
Thin gruel or broth, 5 quarts.
Epsom or common salts, 6 ounces.

2.
6565. *Clyster for Gripes.*

Mash two moderate-sized onions.
Pour over them oil of turpentine, 2 ounces.
Capsicum, or pepper, half an ounce.
Thin gruel, 4 quarts.

3.
6566. *Nutritious Clyster.*

Thick gruel, 3 quarts.
Strong sound ale, 1 quart.
or 4.
Strong broth, 2 quarts.
Thickened milk, 2 quarts.

4.
6567. *Astringent Clyster.*

5.
Tripe liquor, or suet boiled in milk, 3 pints.
Thick starch, 2 pints.
Laudanum, half an ounce.
or 6.

Alum whey, 1 quart.
Boiled starch, 2 quarts.

6568. *Cordial Balls.*

Gentian powdered, 4 ounces.
Ginger, do., 2 ounces.
Coriander seeds, do., 4 ounces.
Carraway do., 4 ounces.
Oil of aniseed, a quarter of an ounce.
Make into a mass with honey, treacle, or lard, and give one ounce and a half for a dose.

6569. *Chronic Cough Balls.*

1.
Calomel, 1 scruple.
Gum ammoniacum,
Horse radish, of each 2 drachms.
Balsam of Tolu,
Squills, each 1 drachm.
Beat all together, and make into a ball with honey, and give every morning fasting.

6570. *Drink for the same.*

2.
Tar water,
Lime water, of each half a pint.
Tincture of squills, half an ounce.

6571. *Powder for the same.*

3.
Tartar emetic, 2 drachms.
Powdered foxglove, half a drachm.
Powdered squill, half a drachm.
Calomel, 1 scruple.
Nitre, 3 drachms.
Give every night in a malt mash.

6572. *Diuretic Balls.*

Resin, yellow, 1 lb.
Nitre, half a pound.
Horse turpentine, half a pound.
Yellow soap, quarter of a pound.
Melt the resin, soap, and turpentine over a slow fire; when cooling, add the

nitre. For a strong dose, an ounce and a half; for a mild one, an ounce. It should be kept in mind, that mild diuretics are always equal to what is required; and that strong diuretics are always hurtful.

6573. *Diuretic Powders.*

Yellow resin, powdered, 4 ounces.
Nitre, do., 8 ounces.
Cream of tartar, ditto, 4 ounces.
Dose—6, 8, or 10 drachms nightly, which some horses will readily eat in a mash.

6574. *Urine Drink.*

Glauber's salts, 2 ounces.
Nitre, 6 drachms.
Dissolve in a pint of warm water.

6575. *Embrocations. — Cooling for Inflammations.*

1.
Goulard's extract, half an ounce.
Spirit of wine or brandy, 1 ounce.
Soft water, 1 quart.

2.
Mindererus spirit, 4 ounces.
Water, 12 ounces.

6576. *For Strains.*

Bay salt, bruised, half a pound.
Crude sal ammoniac, 2 ounces.
Sugar of lead, quarter of an ounce.
Vinegar, 1 pint and a half.
Water, 1 pint.

6577. *For the Eyes.*

1.
Sugar of lead, 1 drachm.
White vitriol, 2 scruples.
Water, 1 pint.

2.
Brandy, 1 ounce.
Infusion of green tea, 4 ounces.
Tincture of opium, 2 drachms.
Infusion of red roses, 4 ounces.

3.
Rose water, 6 ounces.
Mindererus spirit, 3 ounces.

4.
Corrosive sublimate, 4 grains.
Alcohol, 1 ounce.
Lime water, 1 pint.

5.
Alum, powdered, 1 drachm.
Calomel, half a drachm.
Mix and insert a little at one corner of the eye. The custom of blowing it in alarms the horse.

6578. *Fever Powders.*

1.
Tartar emetic, 2 drachms.
Nitre, 5 drachms.

2.
Antimonial powder, 2 drachms.
Cream of tartar,
Nitre, of each 4 drachms.

6579. *Fever Drink.*

3.
Sweet spirit of nitre, 1 ounce.
Mindererus spirit, 6 ounces.
Water, 4 ounces.

6580. *Epidemic Fever Drink.*

4.
Sweet spirit of nitre, 1 ounce.
Simple oxymel, 6 ounces.
Tartar emetic, 3 drachms.

6581. *Malignant Epidemic Fever.*

5.
Simple oxymel,
Mindererus spirit,
Beer yeast, of each, 4 ounces.
Sweet spirit of nitre, 1 ounce.

6582. *Fumigations for purifying infected Stables, Sheds, &c.*

Manganese, 2 ounces.
Common salt, ditto.
Oil of vitriol, 3 ounces.
Water, 1 ounce.

Put the mixed manganese and salt into a basin; then, having before mixed the vitriol and water very gradually, pour them by means of tongs, or any thing that will enable you to stand at a sufficient distance, on the articles in the bason gradually. As soon as the fumes rise, retire and shut up the door close.

6583. *Hoof Liquid.*

Oil of turpentine, 4 ounces.
Tar, 4 ounces.
Whale oil, 8 ounces.
This softens and toughens the hoofs extremely, when brushed over them night and morning.

6584. *Purgng Medicines*

Balls—very mild.
Aloes, powdered, 6 drachms.
Oil of turpentine, 1 drachm.

Mild.
Aloes, powdered, 8 drachms.
Oil of turpentine, 1 drachm.

Strong.
Aloes, powdered, 10 drachms.
Oil of turpentine, 1 drachm.
The aloes may be beaten with treacle to a mass, adding, during the beating, the oil of turpentine. All spices, oil of tartar, cream of tartar, jalap, &c. are useless, and often hurtful additions.

6585. *Liquid Purge.*
Epsom salts, dissolved, 8 ounces.
Castor oil, 4 ounces.

Watery tincture of aloes, 8 ounces.
Mix. — The watery tincture of aloes is made by beating powdered aloes with the yolk of egg, adding water by degrees; by these means half an ounce of aloes may be suspended in eight ounces of water; and such a purge is useful when a ball cannot be got down, as in partial locked jaw.

6586. *Scalding Mixture for Pole Evil.*
Corrosive sublimate, finely powdered, 1 drachm.
Yellow basilicon, 4 ounces.

6587. *Foot Stoppings.*
Horse and cow dung, each about 2 lbs.
Tar, half a pound.

6588. *Wash for coring out, destroying Fungus, or proud Flesh, &c. &c.*
Lunar caustic, 1 drachm.
Water, 2 ounces.

6589. *Wash for Mange.*
Corrosive sublimate, 2 drachms.
Spirit of wine or brandy, 1 ounce.
Decoction of tobacco,
Ditto of white hellebore, of each 1 pint.
Dissolve the mercury in the spirit, and then add the decoctions.

6590. *Ointments for Healing.*
1.
Turner's cerate, 4 ounces.
White vitriol, powdered, half a drachm.
Lard, 4 ounces.

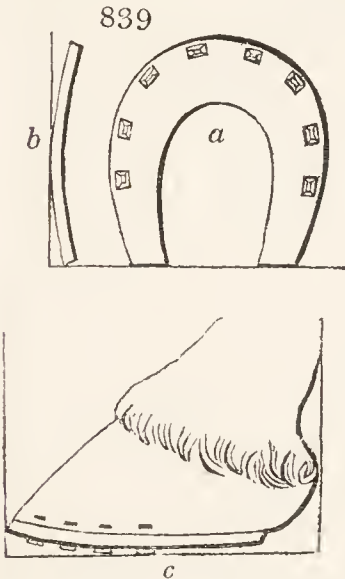
6591. *For Digesting.*
2.
Turner's cerate, 2 ounces.
White vitriol, 1 drachm.
Yellow basilicon, 5 ounces.

6592. *For Mange.*
Sulphur vivum, 8 ounces.
Arsenic in powder, 2 drachms.
Mercurial ointment, 2 ounces.
Turpentine, 2 ounces.
Lard, 8 ounces.
Mix, and dress with every morning.

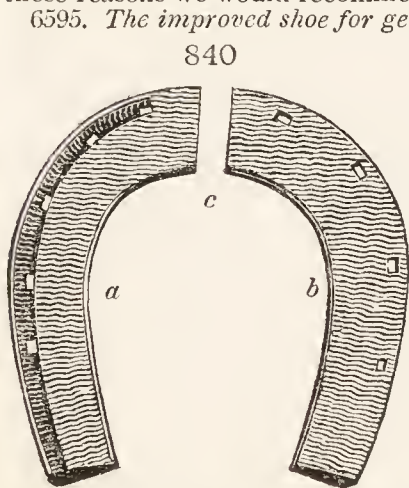
6593. *For Scab or Shab in Sheep, Mollenders and Sellenders in Horses, and foul Blisters and Eruptions in Cattle in general.*
Camphor, 1 drachm.
Sugar of lead, half a drachm.
Mercurial ointment, 1 ounce.

SECT. VIII. *Shoeing of Horses.*

6594. *The importance of the subject of shoeing to the agriculturist is sufficiently attested by the immense number of inventions which the ingenuity of philosophers and artists are every day devising, to render the system complete.* Almost every veterinary professor has his favourite shoe; and we find one of the most ingenious of the present day endeavouring to force on our notice, and introduce into our stables, the French method; which, with the exception of the mode of nailing on, White observes, is the very worst he ever saw. The French shoe (*fig. 839 a*) has a wide web towards the toe, and is concave above and convex below (*b*), on the ground surface, by which neither the toe nor heel touch the ground (*c*); but the horse stands pretty much in the same way with an unhappy cat, shod by unlucky boys with walnut shells. But as Blaine observes, in reference to these inventions, "No one form of foot defence can be offered as a universal pattern." It is, he continues, plain that the principles of shoeing ought to be those that allow as little departure from nature as circumstances will justify. The practice also should be strictly consonant to the principles; and both ought to consist, first, in removing no parts but those which, if the bare hoof were applied to natural ground, would remove of themselves. Secondly, in bringing such parts in contact with the ground (generally speaking) as are opposed to it in an unshod state; and above all, to endeavour to preserve the original form of the foot, by framing the shoe thereto; but never to alter the foot to the defence. The shoe at present made at the forges of the most respectable smiths in the cities and large towns throughout the kingdom, if it have not all the requisites, has however, by degrees, been so improved, that with a few additional alterations, neither difficult to direct or adopt, it is the one we shall hold



up as the most eligible for general shoeing. It is not that a better might not be offered to notice; and, in fact, such a one we shall present to our readers; but so averse are the generality of smiths from having any improvements forced on them, and so obstinately determined are they to adhere to the forms handed down to them by their forefathers, that their stupidity or malevolence, or both, frequently makes the improvement itself, when seemingly acquiesced in, a source of irreparable injury. It is for these reasons we would recommend to agriculturists in general a modified shoe of the common stamp.



6595. *The improved shoe for general use (fig. 840.), is rather wider than what is usually made.* Its nail holes (*a*) extend no further towards the heels than is actually necessary for security; by which the expansion of these parts is encouraged, and contraction is avoided. To strengthen the attachment, and to make up for this liberty given to the heels, the nails should be carried around the front of the shoe (*c*). The nail holes, on the under or ground surface of the shoe (*a*), are usually formed in a gutter, technically called the *fullering*; but in the case of heavy treading powerful horses this gutter may be omitted, or if adopted, the shoe in that part may be steeled. The web should be quite even on the foot or hoof surface (*b*), and not only be rather wider, but it should also have rather more substance than is common: from half an inch to five eighths in thickness, according to circumstance, forms a fair proportion; when it is less it is apt, in wearing, to bend to pressure and force out the clinches. A great error is committed in setting shoes out so much wider than the heels themselves: this error has been devised to correct another, which has been that of letting horses go too long without shoeing; in which case, if the heels of the shoe were not too wide originally, as the foot grew, they became lost within the heels; and were thus bruised and produced corns: but as we will suppose

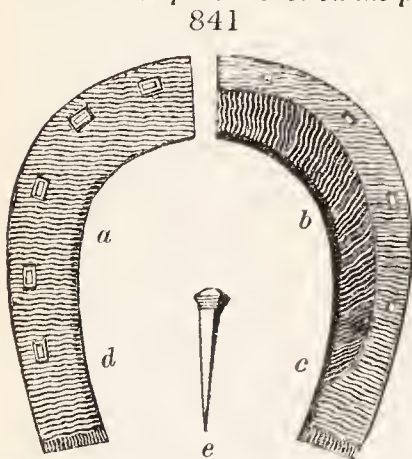
that few will wish to enter into a certain error to avoid an uncertain one, so we recommend that the heels of the shoe should stand only wide enough to prevent the expansion of the quarters pushing the heels of the feet over the outer edge of the heels of the shoe: for which purpose, if the iron project rather less than a quarter of an inch, instead of three eighths, or even half an inch, as it frequently does, many advantages will be gained. Whoever attentively examines a shoe *well set off* at the heels, as it is termed, will find only one third of its flat surface protecting the heels; the remainder projects beyond, and serves but to form a shelf to lodge dirt on; or as a convenient clip for another horse to tread on; or for the wearer to cut his own legs with; or to afford a more ready hold for the suction of clayey grounds to force off the shoe by. The heels of the common shoe are likewise not in general sufficiently long for the protection of the foot; and which defect, more than a want of width, causes the tendency to press on the crust of the heels. It is further to be observed, that if the decreased width of the outer standing of the heels, and the increased width of the web, should make the inner angle of the shoe heel in danger of intertiring with the frog, the corner may be taken off. In forging this shoe, it may be bevelled, or left plain on both surfaces, or rather nearly so, for it is usual with most smiths to thin it in some degree towards the inner edge. This shoe is applicable to most feet, is easily formed, and as such, in country places is all that can be expected.

6596. *The injurious effects of bad shoeing would only require to be known to excite every endeavour to obviate them; and there are some circumstances in the more common shoes of country smiths that ought*

to be impressed on the mind of every agriculturist, and guarded against by every one who possesses a horse. It is too frequently observed that the ground side of their shoe is convex, and that the inward rim, when the foot is on the ground, is the lowest part; on which it is evident the weight must first press; and by which pressure, the crust will be forcibly thrust on the extreme edge of the shoe; and the only resistance offered to its being forced from it, depends on the nails and clinches, instead of its just application to the ground, and the support derived from the uniform pressure of the whole. Every shoe should therefore be perfectly level on its ground surface: nor should any shoe be put on that has not been tried on a *plane iron* purposely made for such trial; which irons are kept in some smithies, but are absent from too many. The substance of the shoe should be the same throughout, forming two parallel lines of upper and under surface; in plain language, the heels, instead of being clubbed as is too frequent, should be the exact thickness of the toe. Neither should the width at the heels diminish in the proportion it usually does; on the contrary, for a perfectly formed foot, the web should present a uniform width throughout.

6597. *Varieties in form of foot, differences in size, weight, and uses of horses*, will necessarily make deviations in the form and substance of shoes. The very shoe recommended may be considered as a variation from what would be immediately necessary, were the feet generally perfect; but it is to be considered that there are but very few feet but what have undergone some unfavourable alteration in their form, which makes them very sensible to concussion. It is for this reason, therefore, that it is recommended that a shoe be used, for general purposes, somewhat wider and thicker than the common one. In weak, tender, flexible feet, it will be found particularly advantageous; and here the benefit of wide heels to the shoe will be most apparent. Good as the roads now are, yet most horses are occasionally subjected to travel on bad ones; some know no other: to these the addition of one, or at the most, two ounces to each shoe is nothing; but the ease to the horse, and its superior covering, as well as support, is incalculable. In very young, very light, and very firm feet, the width and substance may be somewhat diminished at pleasure, and particularly in situations where the roads are uniformly good; but a very long and extensive experience has assured us, that the shoe portrayed is one well calculated to meet the ordinary purposes of travelling, and the present state of the art of horse-shoeing.

6598. *An improved shoe on the present plan* (fig. 841.), would be found to unite all the perfections of the modern English improvements, with some derived from our neighbours the French. What has since been called a *seated shoe* was introduced by Osmer; but from the obstinacy and ignorance of smiths, as it could not be brought into general use, it became little thought of, until revived by Clark of Edinburgh; by whom it was patronised and recommended. It finally was taken up by Moorcroft, and has ever since attracted some attention, and continues to be forged in some shops where the work is superiorly done; and where the employers have liberality enough to pay for such work, and judgment enough to discriminate between its advantages and those of the common shoe. If to this shoe were added the French mode of fastening it to the foot, we think the improvement would almost shut out all others. On examining the figure it will be seen that this shoe presents a flat surface opposed to the ground (a), but a concave one towards the sole (b); but that this concavity does not begin, as in some seated shoes, near the outer edge, but embraces two thirds only of the web, leaving by this means a sufficient surface for the crust: but this bevelling is not intended to reach the heels; it stops short of them (c), leaving the web



at this part plain for the heels to rest upon. The great advantages of this seating are, first, that as the crust rests on a flat surface instead of an inclined plane, as most of the common forged shoes present, so its position is maintained entire, and the inclination to contraction is in a great degree avoided. The nailing on of this shoe we would recommend to be after the French method, which consists in conical nail holes, punched with a square countersink (d), into which are received conical nails (e); which exactly fill up the countersink; by which means so long as any part of the base of the nail remains, the shoe must be held firmly on, and which is not the only advantage gained; for the nail holes being obliquely formed, and at some distance from the outer rim, act less detrimentally on the crust of the foot.

6599. *To prepare the foot for the application of the shoe* is also an important consideration. Avoid taking off more than one shoe at a time; otherwise the edges of the crust become broken away. Observe that the clinches are all carefully removed. Let the rough edges of the crust be rasped away; after which, the sole should be pared throughout until a strong pressure with the thumb can produce some yielding: too strong a sole tends to heat and contraction, too weak a one will not require paring. In this paring imitate the natural arch of the sole as much as possible. The line of concavity should not begin, as it usually is made to do, from the extreme margin of the foot, but should begin from the inner line of the crust only; by which means the crust, or outer wall of the hoof, will have a firm bearing on the flat surface of the shoe. Let no heated shoe be applied to correct the inequalities that may be left, unless it is for a moment, only to observe, but not burn them; but still more carefully avoid putting a plane shoe on an uneven foot. The portion of sole between the bars and quarters (fig. 836. d) should be always pared out as the surest preventive against corns. The heels also should be reduced to the general level of the foot, never allowing their hardness to serve as an excuse for being left; neither suffer the inner heel to be lowered more than the outer. After all the rest has been done, the frog should be so trimmed as to remain on an exact level with the returns of the heels, and no more. The custom of taking away the point or angle of the horny inflexions of the heels, under the false term of opening the heels, is to be carefully avoided. Let all these operations be performed with the drawing knife. The butteris should never be allowed to come near the foot of any horse but the largest and coarsest of the cart breed.

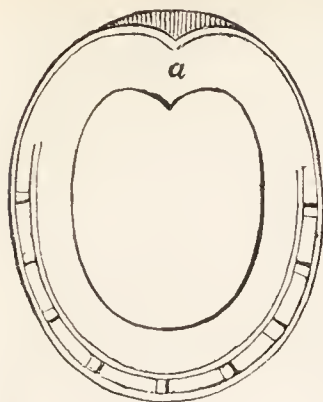
6600. *The shoes for the hind feet are somewhat different to the fore*, being a little squarer at the toe for about an inch; to which squareness the hoof is to be also adapted by rasping it slightly so, avoiding, however, to do it injuriously. By this mode a steady point of bearing is afforded to the hinder feet in the great exertions they are often called upon to make in galloping, leaping, &c. They are, when thus formed, less liable, also, to interfere with the fore shoes by clicking. When horses *click* or *over-reach* very much, it is also common to square, or rather to shorten the toes of the hinder shoes; but not to do so by the horn; by which, the hoof meets the middle of the fore shoe instead of the shoe itself; and the unpleasant noise of the stroke or click of one foot against the other is avoided.

6601. *Varieties which necessarily occur in shoeing*. The *bar shoe* (fig. 842.) is the most important variety; and it is to be regretted that so much prejudice prevails against the use of this shoe, which can only arise from its supposed unsightly appearance as betokening unsoundness. As a defence to weak thin feet it is invaluable, as it removes a part of the pressure from the heels and quarters, which can ill bear it, to the frog which can well bear it; but a well formed bar shoe should not have its barred part raised into an edge behind, but such part should be of one uniform thickness throughout the web of the bar, which, instead of being the narrowest, should be the widest part of the shoe. The thickness of the bar should be greater or less (a), so as to be adapted to take only a moderate pressure from the frog. When the frog is altogether ulcerated away by thrush, the bar may be altogether plain; but this form of shoe is still the best for these cases, as it prevents the tender surface from being wounded. In corns this shoe is invaluable, and may then be so made as to lie off the affected part, which is the great desideratum in corns.

6602. *The hunting shoe* is made lighter than the common one, and it is of consequence that it is

made to sit as flat to the foot as it can safely do without pressing on the sole; by which the great suction in clayey grounds is much lessened. Hunting fore-shoes should also be as short at the heels as is consistent with safety to the foot, to avoid the danger of being pulled off by the hinder shoes: nor should the web project at all. It is the custom to turn up the outer heel to prevent slipping; which is done sometimes to both fore and hind feet, and sometimes only to the latter. As this precaution can hardly be avoided in hilly slippery grounds, it should be rendered as little hurtful as possible by making the tread equal; to which purpose, thicken the inner heel and turn up the outer. This is better than lowering the outer heel to receive the shoe, which still leaves both the tread and foot uneven.

842

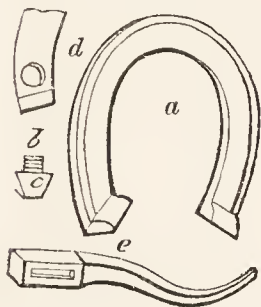


6603. *The racing shoe, or plate*, is one made as light and slender as will bear the weight of the horse, and the operations of forging, grooving, and punching; to enable it to do which, it ought to be made of the very best Swedish iron. Three, or at most four, nails are sufficient on each side; and to avoid the interfering of the hind with the fore feet, the heels of the fore shoes are made as short as they can safely be. As racers are shod in the stable, the owners should be doubly careful that the plate is an exact fit. Many pairs ought to be brought and tried before any are suffered to be put on, and this is more important than is at first considered.

6604. *Grass shoes or tips* are very short pieces placed on the toe alone, in horses turned to grass in summer; at which time they are essentially necessary to guard the fore feet, which otherwise become broken away, and irretrievably injured. They should be looked at occasionally to see that they do not indent themselves into the soles.

6605. *Frost shoes* (fig. 843 *a*) have the ends turned up to prevent the foot from sliding; unless the turning up or calkin be hardened, they soon wear level and require to be renewed, to the injury of the foot by such frequent removals. To remedy this, many inventions have been tried; one of the best of these is that of Dr. Moore, in which the frost clip is made distinct and moveable by means of a female screw (*b*) worked in it, to which a knob or wedge (*c*) and male screw (*d*) are adapted; a key (*e*) being used for fixing or removing it.

843



6606. *High calkins*, or turn-ups, however objectionable in general shoeing, yet, in precipitous counties, as those of Devonshire, Yorkshire, and of Scotland, &c., are absolutely necessary for their draught horses. It greatly obviates the evils of uneven pressure, if a calkin be also put to the toe; and it would be still better were these calkins steeled, particularly the fore ones.

6607. *The shoeing of diseased feet* is necessarily very various, and is too often left to the discretion of the smith, by which the evils themselves are greatly aggravated, if he be ignorant. The most prominent alterations for these purposes will be found described under the respective diseases of the feet requiring them.

6608. *Horse pattens* are in use by some cultivators who occupy soft or mossy soils. Those esteemed the best are constructed of alder or elm, and are fixed to the hoof by means of three links and a staple, through each of which passes a leathern strap that goes twice round the hoof, and is fastened by a buckle. The staple is placed behind the patten, which is ten inches one way, by ten and a half the other. The links are about three inches in length, and rivetted through pieces of hoop iron to prevent the wood from splitting. After numerous trials, it has been found that pattens made in this way answer the purpose better than any other kind. (*Farm. Mag.*)

SECT. IX. *Criteria of the Qualities of Horses for various Purposes.*

6609. *The general criteria of the qualities of a horse* are derived from inspection and trial. His outward appearance among judges affords a pretty just criterion of his powers, and a moderate trial usually enables the same judgment to decide on the disposition to exercise such powers.

6610. *The criteria of a horse derived from his colour* have been already noticed. (6298.) As a general principle dark are preferable to light horses, except in the instance of black, which has fewer good horses within its range, particularly in the lighter breeds, than any other. Grey horses are also, in some degree, an exception to the rule; for there are many good greys. Bay and brown are always esteemed colours.

6611. *The criteria of action* are derived from a due consideration of the form generally, and of the limbs particularly; as well as from seeing the horse perform his paces in hand.

6612. *The criteria of hardihood* are derived from the form of the carcass, which should be circular, or barrelled; by which food is retained, and strength gained to perform what is required. Such horses are also generally good feeders.

6613. *The criteria of spirit, vigour, or mettle*, as it is termed, are best derived from trial. It should always be kept in mind, that a hot fiery horse is as objectionable as a horse of good courage is desirable. Hot horses may be known by their disinclination to stand still; by their mettle being raised by the slightest exercise, especially when in company. Such horses seldom last long, and under accident are impetuous and frightened in the extreme. A good couraged horse, on the contrary, moves with readiness as well alone as in company: he carries one ear forward and one backward; is attentive and cheerful, loves to be talked to, and caressed even while on his journey; and if in double harness, will play with his mate. Good couraged horses are always the best tempered, and, under difficulties, are by far the most quiet, and least disposed to do mischief.

6614. *The criteria of a race-horse*, derived from form, are, that he have the greatest possible quantity of bone, muscle, and sinew, in the most condensed form. There should be a general length of parts to afford stretch, scope, and elasticity, with great muscles hardened by condition, to act on the length of these parts advantageously. In particular his hind limbs should be furnished with ample thighs and broad hocks, which should be low set. His fore-arm ought also to be broad, and the knee, like the hock, should be near the ground.

6615. *The criteria of a hunter* are, that he have somewhat similar proportions with the racer, but with more bulk to enable him to continue his exertions longer, and to carry more weight. In him, a good carcass is essentially necessary to fit him to go through a long chase; and the more, if he be required to hunt more than one or two days in the week. Some light carcassed horses will do one day's hunting work a week very well, but knock up at more. The hunter should be well formed in his loins, and well let down in his thighs to propel him forward in his gallop, and give him strength to rise sufficiently to cover his leaps. It is also of great use to a hunter to be a good trotter; many such horses, when fatigued, break out of the gallop and relieve themselves by trotting, particularly over heavy ground.

6616. *The criteria of a hackney*. If it be necessary that the hackney be well formed behind to give him strength, and to propel him forward, it is even of more consequence that he be well formed before; and in this kind of horse the hind parts are in some measure subordinate to the fore, as safety is preferable to speed. The head in the hackney should be small, and well placed on a neck of due length and substance to make a proper *appui* for the bridle, and that proper resistance to the hand, so pleasant to the feel, and

so necessary for ease and safety. The shoulders should be oblique and well furnished with muscle, but not heavy; and the withers in particular should be high. The elbows should be turned rather out than in, and the legs should stand out straight, and by no means fall under the horse, or it betokens a stumbler. The pasterns should neither be too oblique, which bespeaks weakness; nor too straight, which wears the horse out, and is unpleasant to the rider. The carcase should be round, or the horse will be washy and weak; the loins straight, wide, and ribbed home; the thighs of good substance; and although the being cat-hammed, or having the hocks turned inwards, is defective in beauty, it often bespeaks a trotter.

6617. *The criteria of a cavalry horse* are, that he have considerable extension of bulk or size, to enable him to carry weight, with good carcase to allow him to feed coarsely, and yet thrive at picket or on service. He should have also liberty of action; but great speed is not requisite. The best cavalry horses are those formed of the united properties of hackneys and very light draught horses.

6618. *The criteria of road horses for quick draught*, or coach, chariot, stage and post chaises, &c., are derived from the immediate purposes for which they are intended; as requiring either strength or speed in greater proportions. To make them safe, the fore-hand should rise, the back should be straight, the step should be short but quick, which fatigues least. As they approach the hunter in form, they are best fitted for quick work; and as they resemble the best kind of light agricultural horses, they are calculated for heavy draught, as coaches, &c. But in all, a portion of blood gives courage, durability, and condenses strength into lessened bulk; by which activity is gained. It is of great consequence to a coach-horse that the neck and head be so formed as to be enabled to rein-in well to the bridle.

6619. *The criteria of a dray-horse* are, that he be very broad-breasted and muscular, and thick in the shoulders, which should not lie backward. Nor should the fore-hand be up, as recommended in the road-horse; for, by holding up their heads, such horses may be choked by the collar, as they would, if so formed, draw too much by the throat, and their wind being thus stopped, would be in danger of falling down. The neck of a dray-horse is not the better for being long, and the head should be proportionate to it. Like all horses, he should be chosen with short legs, and good strong hoofs. He ought to be thick in his thighs, and large in bone; but above all, he ought to be a steady collared horse, with courage to make him true to a severe pull; and yet, without a hot fiery spirit to make him fretful.

6620. *The criteria of a waggon horse* are, in some respects, different from those of the dray-horse. He should be more weighty, and altogether larger. Rapidity of motion is greatly subordinate, in the heavy stage-waggons usually seen on our roads, to strength. It is all collar work; nothing is gained from the momentum of the dragged mass, which, the instant the pull ceases, stands still. The waggon horse should be patient in the extreme; willing to lie to his collar up-hill, and yet settle into his share of work on level ground. As his exertions are constant, it is of the greatest consequence that he be a good feeder.

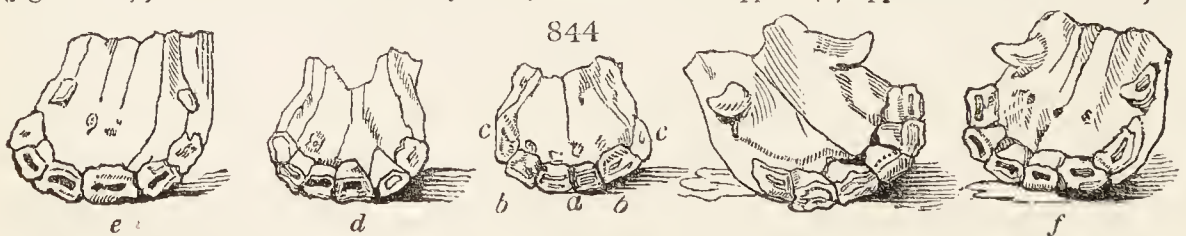
6621. *The criteria of a horse peculiarly adapted to the labours of agriculture*, are thus given by Culley:—His head should be as small as the proportion of the animal will admit; his nostrils expanded, and muzzle fine; his eyes cheerful and prominent; his ears small, upright, and placed near together; his neck, rising out from between his shoulders with an easy tapering curve, must join gracefully to the head; his shoulders, being well thrown back, must also go into his neck (at what is called the points) unperceived, which perhaps facilitates the going much more than the narrow shoulder; the arm, or fore-thigh, should be muscular, and tapering from the shoulder, to meet a fine, straight, sinewy, and bony leg; the hoof circular, and wide at the heel; his chest deep, and full at the girth; his loins or fillets broad and straight, and body round; his hips or hooks by no means wide, but quarters long, and the tail set on so as to be nearly in the same right line as his back; his thighs strong and muscular; his legs clean and fine-boned; the leg-bones not round, but what is called *lathy* or flat.

6622. *The chief points in a farming cart-horse*, in the opinion of the author of the *New Farmer's Calendar*, are, "neck not long, nor too thick; short legs, rather flat than round and gummy; fore-feet even, not too distant; wide chest; strong, but not high, shoulders; considerable length of waist, supported by a wide loin; quarters full, and rather raised; strong muscular thigh; size, fifteen hands one inch to sixteen hands high. Being somewhat forelow gives them an advantage in draught; and a moderate length of waist insures speed in the walk.

6623. *The horse used in husbandry*, according to the writer of the *Experienced Farmer*, ought to be larger, but in other respects like the road horse: and, instead of walking two or three miles an hour, be able to walk four or five. In that case he would be able both to plough more land in a given time, and work in the cart or waggon with more despatch, when wanted. In harvest time, a nimble and strong horse is valuable. In drawing manure into the field, or corn to the market, the farmer will also find his account in strength and activity; for, as the draught in all these cases is light one way, such horses would do their business with speed. The small farmer need not with this kind of horse keep an idle one; he might carry his master to market, and plough the remainder of the week.

6624. *In a horse for the plough*, according to Brown, both strength and agility are required; a dash of blood, therefore, is not disadvantageous. It is not size that confers strength, the largest horses being often soonest worn out. A quick even step, an easy movement, and a good temper, are qualities of the greatest importance to a working horse; and the possession of them is of more avail than big bones, long legs, and a lumpy carcase. To feed well is also a property of great value; and this property, as all judges know, depends much upon the shape of the barrel, deepness of chest, strength of back, and size of the hips or hooks with which the animal is furnished. If straight in the back, and not over short, high in the ribs, and with hooks close and round, the animal is generally hardy, capable of undergoing a great deal of fatigue, without lessening his appetite, or impairing his working powers; whereas horses, that are sharp pointed, flat ribbed, hollow backed, and wide set in the hooks, are usually bad feeders, and soon done up when put to hard work.

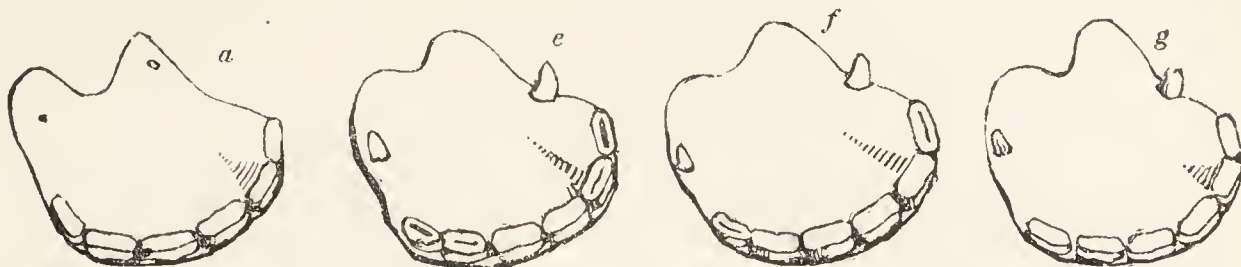
6625. *The criteria of a horse's age* are derived from the appearance of the teeth. According to La Fosse the younger, there are these appearances. The horse is foaled with six molar or grinding teeth in each jaw (*fig. 844. a*); the tenth or twelfth day after, the two front nippers (*a*) appear above and below, and in



fourteen or fifteen days from this, the two intermediate (*b b*) are pushed out; the corner ones (*c c*) are not cut till three months after. At ten months the incisive or nippers are on a level with each other, the front less than the middle, and these again less than the corners; they at this time have a very sensible cavity (*d*). At twelve months this cavity becomes smaller, and the animal appears with four molar teeth on each side, above and below, three of the temporaneous or colts', and one permanent or horse tooth: at eighteen the cavity in the nippers is filled up, and there are five grinders, two of the horse, and three temporaneous: at two years (*fig. 845.*), the first of the colt's molar teeth in each jaw, above and below, are displaced. at two years and a half, or three years, the front nippers fall and give place to the permanent ones: at three and a half the middle nippers are likewise removed, at which period the second milk-molar falls: at four years the horse is found with six molar teeth, five of his new set, and one of his last: at four years and a half the corner nippers of the colt fall and give place to the permanent set

(fig. 844. e), and the last temporaneous grinder disappears: at five years old the tushes in the horse usually appear. at five and a half they are completely out, and the internal wall of the upper nippers, which

845



before was incompletely formed, is now on a level with the rest; at this period the incisive or nippers have all of them a cavity formed in the substance between the inner and outer walls (fig. 844. f), and it is the disappearance of this that marks the age: at six years those in the front nippers below are filled up (fig. 845. e), the tushes are likewise slightly blunted: at seven years the mark or cavity in the middle nippers is filled up, and the tushes a little more worn (fig. 845. f): at eight years old the corner nippers are likewise plain, and the tushes are round and shortened (fig. 845. g). In mares, the incisive or nippers alone present a criterion (fig. 845. a); at this period the horse is said to be aged, and to have lost his mark; but among good judges the teeth still exhibit sufficient indications. At nine the groove in the tushes in worn away nearly, and the nippers become rather rounded: at ten these appearances are still stronger: at twelve the tushes only exhibit a rounded stump, the nippers push forward, become yellow, and as the age advances, appear triangular and usually uneven.

6626. *M. St. Bel*, the late professor of the English Veterinary College, used to assert, that after eight years the cavities in the anterior or upper incisive teeth are filled up with equal regularity; thus from eight to ten the front ones were filled up, from ten to twelve the two middle, and from twelve to fourteen those of the corner; but though some pains have been taken to ascertain this, it does not appear that the disappearance of the cavities in these teeth is attended with sufficient regularity to warrant implicit confidence.

6627. *To make a colt appear older than he really is*, both breeders and dealers very commonly draw the nippers, particularly the corner ones; by which means the permanent set which are underneath immediately appear, and the animal is thus fitted for sale before he otherwise would be.

6628. *To make a horse look younger than he really is*, dealers perform an operation on the teeth called bishopping (from the name of a noted operator); which consists in making an artificial cavity in the nippers, after the natural one has been worn out by age, by means of a hard sharp tool; which cavity is then burned black by a heated instrument. But no art can restore the tushes to their form and height, as well as their internal grooves. It is, therefore, common to see the best judges thrust their finger into a horse's mouth, contenting themselves with merely feeling the tush. To less experienced judges other appearances present themselves as aids. Horses, when aged, usually become hollow above the eyes, the hoofs appear rugged, the under lip falls, and if grey, they become white. In this country, where horses are so early worked before the frame is consolidated, and where afterwards they continue to be exerted unceasingly on hard roads, it is not uncommon to find a horse at six years old feeble, debilitated, and exhibiting all the marks of old age, except in his mouth; on the contrary, when the animal falls into other hands, at ten or twelve he has all the vigour of youth, and his teeth are the only parts that present an indication of age: it is, therefore, more useful to examine the general appearance of the animal, than to be guided altogether by the marks in the teeth; a too strict adherence to which, Blaine observes, lead into great error on the subject of the age of horses. The commonly received marks, he says, grant not a criterion of a third of the natural life of the animal, nor of one half of the time in which he is perfectly useful. Many good judges will not purchase a horse for hunting earlier than eight years old, and regard him only in his prime at twelve. A gentleman at Dulwich has a monument to the memory of each of three several horses which died in his possession at the age of thirty-five, thirty-seven, and thirty-nine years; the latter of which was suddenly taken off by a fit of colic, having been in harness but a few hours before. Culley mentions a horse of forty-five; and an instance lately occurred of one which lived to fifty. Blaine, in continuation, draws the following comparison between the relative situations of the state of the constitution, between the horse and man, under the ordinary circumstances of care towards each: — The first five years of the horse may be considered as equivalent to the first twenty of a man; a horse of ten as a man of forty; of fifteen as a man of fifty; of twenty as a man of sixty; of twenty-five as a man of seventy; of thirty as a man of eighty; and of thirty-five as a man of ninety. (*Vet. Outlines*, p. 35.)

SECT. X. *Breeding of Horses.*

6629. *The general principles of breeding* we have already laid down at length (2023.), and have here to notice what are considered the best practices in the choice of stallions and mares, and in the treatment of the latter during pregnancy. Unfortunately, however, much less attention has been paid to breeding horses, than to breeding cattle or sheep; though, as Brown has observed, a pound of horse-flesh is worth two of that of any other stock; and it costs just as much to breed a bad horse as a good one. Every one, an eminent writer observes, exercises some degree of judgment in regard to the stallion; but there are few breeders, comparatively, who hesitate to employ very ill-formed and worthless mares, and often solely because they are unfit for any thing else than bringing a foal. All the best writers on agriculture reprobate this absurd and unprofitable practice. "In the midland counties of England, the breeding of cart horses is attended to with the same assiduity as that which has of late years been bestowed on cattle and sheep; while the breeding of saddle horses, hunters, and coach horses is almost entirely neglected; or left almost wholly to chance, even in Yorkshire, — I mean as to females. A breeder here would not give five guineas for the best brood mare in the kingdom, unless she could draw or carry him occasionally to market; nor a guinea extraordinary for one which could do both. He would sooner breed from a rip, which he happens to have upon his premises, though not worth a month's keep. But how absurd! The price of the leap, the keep of the mare, and the care and keep of her progeny, from the time they drop to the time of sale, are the same, whether they be sold from ten to fifteen, or from forty to fifty pounds each." (*Marshal's Economy of Yorkshire*, vol. ii. p. 166.) A little consideration will show this error in a still stronger light, when we consider, that united with the characteristic marks common to the breed in general, the progeny of two individuals always exhibits traits of resemblance to each; and as the defects are as certainly propagated as the excellencies, so a neglect in being equally careful in our selection of the female as the male parent is actually bespeaking deformity. It being also now and then observed, that a stronger resemblance is borne to the mother than to the father; so the chances of a worthless colt are increased. It having likewise been remarked, that every variety has a tendency to breed back towards its original, so a breed thus constituted can hardly admit of amelioration, but remains stamped by its original erroneous selection. These remarks, it is hoped, will encourage our breeders to be less indifferent to the choice of their breeding mares.

6630. *In those districts where the breeding of horses is carried on upon a large scale and a regular plan*, the rearing of stallions forms in some degree a separate branch; and is confined, as in the case of bulls

and rams, to a few eminent breeders. These stallions, which are shown at the different towns in the vicinity, sometimes sent to be exhibited at a considerable distance, are let out for the whole season, or sold to stallion men, or kept by the breeder himself, for covering such mares as may be offered, at a certain price per head; and this varies according to the estimation in which the horse is held, and sometimes according as the mare has more or less of what is called blood. For farm mares, the charge for covering by a stallion of the same kind is commonly about a guinea, with half-a-crown to the groom; and it is a common practice in the North, to agree for a lower rate if the mare does not prove with foal; sometimes nothing more is paid in that case than the allowance to the groom.

6631. *In choosing the parents*, or stallion and mare, regard must be had to the kind of stock desired to be bred. Whatever may be the particular purpose of the breed, a stallion ought first to possess all the general properties of a good horse, and next the characteristic criteria of the desired stock. The produce, whether a male or female, much more frequently acquires and retains the form, make, marks, and disposition of the sire than the dam. On this account, stallions with the least appearance of disease, blemish, or bodily defect of any kind, where there is the slightest probability of its being transmitted to the offspring, should be rejected as improper. And it is even considered by some necessary to descend to the minutiae of symmetry in the head, neck, shoulder, forehead, ribs, back, loins, joints, and pasterns, attending even to a strict uniformity in the form, make, and texture of the hoofs: it is also of importance to ascertain the temper and disposition of both sire and dam, in order to avoid the procreation of vices or imperfections. But provided either parents be free from hereditary infirmities, disorders which arise from accident are of no consequence.

6632. *The general properties required in a breeding mare*, are a good shape, a gentle disposition, a large carcass conformably to her height, and belly well let down; she must be perfectly free from all sorts of blemishes and defects. The size, frame, bone, strength, and blood, will of course be regulated by the purposes of the breeder.

6633. *The mare which is intended to supply draught colts* should, according to the author of the *Synopsis of Husbandry*, be large-limbed, close-jointed, short-docked, wide-chested, home-ribbed, with a capacious body; her eyes good, and her nostrils large and open; in disposition she ought to be gentle and tractable; of a constitution healthy and vigorous, free from any blemishes either hereditary or acquired. The horse should be bold and spirited, well made, and of a kindly disposition; his constitution should be strong, his temper good, and, in short, neither in mind or body ought he to be contaminated with vices or disease of any kind; since on the good qualities and strength of constitution in the sire and the dam depends, in a great measure, the future welfare of the colt.

6634. *The age at which horses should be allowed to breed* is not determined by uniform practice; and is made to depend, in some measure, on the degree of maturity, which, in animals of the same species, is more or less early, according to breed and feeding. Yet it would seem, in general, to be an improper practice to allow animals of any kind to propagate, while they are themselves in a raw unformed state, and require all the nutriment which their food affords, for raising them to the ordinary size of the variety to which they belong. It may, therefore, be seldom advisable to employ the stallion till he is about four years old, or the mare till she is a year older, and if the stallion be five also it is better, and still more so if he be six or seven. But the greater number of mares left for breeding are not very young; being in many cases not allowed to bring foals till they are in the decline of life, or otherwise unable to bear their full share in rural labour.

6635. *Three months before a stallion is sexually employed*, he should be fed with sound oats, peas, or beans, or with coarse bread, and a little hay, but a good quantity of wheat straw; he should be watered regularly, and have long continued walking exercise every day, but he should not be over-heated. If he be not prepared and put in condition, the colts will be likely to be weakly, and the horse himself will become injured, begetting humours, or becoming broken-winded. If he be put to too many mares, he will not last long; his mane and tail will begin to fall off through weakness, and it will be difficult to get up his flesh again by the next year. The number of mares should be proportioned to his strength, and twelve, fifteen, or at the most twenty, are as many as a horse will well serve for in a season. This number, indeed, is thought by many too few, and in Suffolk, we are informed on the best authority, the stallions serve from fifty to seventy, and even eighty mares in a season.

6636. *The usual season for the generative process* is from the beginning of April to the beginning of July. The month of June is considered the best season in this country; although from the middle to the end of May is more approved of on the Continent, particularly in Normandy, where the farmers devote much of their attention to this branch of husbandry; and in which, especially in regard to useful farm horses, they have succeeded, perhaps, beyond those in any other part of Europe. This difference, as to the time when a mare should be allowed to take the horse, in the different countries, is easily reconcilable: a mare goes eleven months and a few days with foal; and the great object with all farmers, where practicable, is to have her covered at such a period as to ensure abundance of grass, and the return of warm and comfortable weather at the period of foaling. An early colt is always to be preferred to one that falls late in the season. It is generally understood, and is an opinion that is believed to be well founded, that a mare may be covered on the ninth day after she has foaled, with a greater degree of success than at any other period. This practice is, of course, often followed; but in such cases the mare ought, Donaldson thinks, to be fed in an extraordinary manner, otherwise it is impossible she can do justice to her present and her future foal. But modern farmers would probably, he says, come nearer their purpose, were they to follow the example of the Romans, and content themselves with one foal in the two years.

6637. *At the season of parturition, there should be a suitable supply of food for the mother and young*. The time of covering mares ought, therefore, to be partly regulated by a due regard to this circumstance, and may be earlier in the south than in the north, where grass, the most desirable food both for the dam and foal, does not come so early by a month or six weeks. In Scotland, it is not advantageous to have mares to drop their foals sooner than the middle of April; and as the period of gestation is about eleven months, they are usually covered in May, or early in June. But if mares are intended to bring a foal every year, they should be covered from the ninth to the eleventh day after foaling, whatever may be the time; and the horse should be brought to them again nine or eighteen days afterwards.

6638. *In breeding horses on a large scale* it is easy to contrive so that all the foals may be brought forth at a time when there is plenty of grass. About the end of May the mares are to be put into an enclosure capable of feeding them as long as the stallion is to be with them, or that they are in season. In this enclosure all the mares are to be put together, as well those which are barren as others. The stallion's hind shoes are to be taken off, but the fore shoes should be left, or tips put on to preserve his feet; then lead him forth, and let him cover a mare twice in hand, to render him more tame and gentle. After this take off the bridle and turn him loose among the rest, where he will become familiar with them, and not one of them will be horsed but when they are in season. There should be a little lodge built up in some part of the enclosure, and peas, beans, oats, bread, and other good food, put into the manger in it, that the horse may retire into it in the scorching heats, and eat what he likes best. He must be thus entertained during the whole time he is with the mares, which is to be about six or seven weeks. Mares that are very fat and gross do not hold well; but those which are moderately fat conceive with the greatest success and ease.

6639. *To bring a mare in season*, it is a common thing to give her a quart of hemp-seed, or twice that quantity, night and morning for eight days before she is brought to the horse. If she refuse it alone, it may be mixed with beans or oats, and will go down; and if the stallion eat of it, it will force him also; but it must be remembered that these provocatives are unnatural, and often defeat their own purposes. They

are therefore seldom now resorted to among intelligent breeders. Still more improper is it to attempt an early horsing, by injecting stimulating fluids up the vagina as is sometimes done; for when it succeeds, the future progeny seldom answers the expectation.

6640. *The treatment of a pregnant mare* is in general little different from that of any other horse. Mares of draught are worked in summer as usual, and more moderately in the ensuing winter, till near the time of foaling; when, if the season be somewhat advanced, even though the pasture be not fully sufficient for their maintenance, they should be turned out to some grass field near the homestead, and receive what additional supply of food may be necessary under sheds adjoining. It is both inconvenient and dangerous to confine a mare about to foal in a common stable, and still more so to leave her loose in a close stable among other horses; and confinement is not much less objectionable after dropping her foal.

6641. *Breeding mares are usually worked through the greatest part of the year*, laying them aside only for a week or two before foaling, and during the summer season, when giving suck to the young foal. In this way, Brown observes, the strength and vigour of the mother is not only weakened, but the size and power of the foal stand a great chance of being diminished, by the exertions of the mother when kept at work. Under these impressions we are led to consider the working of breeding mares as an unprofitable practice. Were they suffered to remain at ease, to roam upon coarse pastures, where sheds were erected in which they might find shelter during inclement weather, we are almost certain that their progeny would enter upon action with increased abilities. The expense of a breeding mare kept in this way would not be great, whilst the advantages would be innumerable. In Yorkshire, and in those midland counties where the breeding and rearing of horses is better understood than in any other part of the island, they are often worked till the very time of foaling. Great care, however, is necessary in working and managing a mare heavy with foal: an over-heat, too severe exercise, a fright, or a sudden and violent jerk, are very apt to cause an untimely birth, whereby the foal is lost, and the life of the mare very much endangered.

6642. *In the mountains of Wales, and in the Highlands of Scotland*, the breeding mares are never worked during the summer. They are driven to the hills and mountains at the close of the barley-seed season, where they remain till the inclemency of the weather forces them to return for shelter. But their scanty subsistence, the labour they are subjected to in procuring their food, and the moistness and coldness of the climate in the latter part of the season, render both themselves and their progeny of but little value and importance.

6643. *Farms*, consisting chiefly of pasture land unfit for feeding, are the situations where breeding is generally carried on. Arable farmers may breed occasionally; but the inconvenience of wanting any part of their working stock at the time of foaling operates almost as a prohibition to the breeding of horses. The greater number of horses are bred in situations where a small portion of arable land is attached to farms chiefly occupied with cattle or sheep; or where the farms are so small as not to afford full and constant employment to the number of horses that must, nevertheless, be kept for the labour of particular seasons.

SECT. XI. *Rearing of Horses.*

6644. *Rearing includes the treatment of the foal till it is fit to work*, or to be put in training for use, and also the treatment of the mother till she has weaned her foal.

6645. *In regard to the treatment of the mare till she has weaned her foal* in England, and in the improved parts of Scotland, a mare after having foaled is turned, together with the foal, into a pasture field, and is allowed two or three weeks' rest, before she is again worked, either in plough or cart; the foal being allowed to suck at pleasure during the time. After having had a few weeks' rest, she is again worked in the usual manner; the foal being commonly shut up in a house during the hours of working. In Yorkshire, some farmers are particularly careful not to allow the mare to go near the foal, after her return from labour, till her udder has been bathed with cold water, and not till most of the milk is drawn from it. These precautions are used with a view of preventing any bad consequences from the foal's receiving over-heated milk. Another practice, and which is superior to the above, is also common in Yorkshire, and in many parts of Scotland:—After the foal is a few weeks old, and has acquired strength and agility enough to follow its mother, it is allowed to attend her in the field during the hours of labour, and to suck occasionally. By this means, not only does the foal receive sufficient exercise; nor can any prejudicial effect happen from the over-heated state of the milk, as the foal is allowed to draw it off repeatedly, and at short intervals; but the little animal becomes hardy, and loses all timidity, and afterwards requires less breaking: these may be considered as the general modes of management in those parts of the kingdom mentioned above, during the period while the foal is allowed to suck its dam, which is usually about six months; that is, from the time of foaling till Michaelmas, which is the period at which foals are generally weaned, or prevented from sucking. Breeding mares are evidently unable to endure the fatigue of constant labour, for some months before and after parturition: this has led a few farmers to rear foals upon cow-milk; but the practice is neither common nor likely ever to become so; and as it is a philosophical fact, well established, that all animals partake, in some measure, of the nature of their foster parent, so there is great reason to fear this practice would prove injurious to foals so reared.

6646. *In weaning the foal* at the end of six or seven months, great care should be taken to keep the mare and foal from the hearing of each other, that neither may fret or pine after the other. The best method will be to confine the foal in a small stable by itself, which should be furnished with a rack and manger, where it may be fed with clean shaken hay, and clean sifted oats, bruised a little in a mill, or chopped carrots, or boiled potatoes. With this management, he will quickly forget his dam, and become gentle and familiarised to his keeper, and in fair weather may be suffered to exercise himself in a pasture adjoining to the stable; but this should be only for a little while in the middle part of a sunny day; the tenderness of the young animal rendering it dangerous to keep him out in the night.

6647. *The treatment of weaned foals* in England, is to put them immediately into a good fresh pasture, where they remain as long as the winter continues moderate. On the approach of winter, they are fed with a sufficient quantity of hay, placed in a stable or hovel, erected in the field for the purpose, and into which they have free access at all times. The next summer they are put into other pastures, commonly the most indifferent on the farm, where they remain till the beginning of the following winter, when they are either allowed to range in the pasture fields, or brought home to the straw-yard. The inclemency of the winter in Scotland, and the great falls of snow which generally take place, render it necessary always to house the foals there during that season.

6648. *During the first winter* foals are fed on hay with a little corn, but should not be constantly confined to the stable; for even when there is nothing to be got on the fields, it is much in their favour to be allowed exercise out of doors. A considerable proportion of succulent food, such as potatoes, carrots, and Swedish turnips (oil-cake has been recommended), should be given them through the next winter, and beans and peas meal has been advantageously substituted for oats; but which, if allowed in a considerable quantity, are injurious to the thriving of the young animal, from their heating and astringent nature.

6649. *During the following summer* their pasture depends upon the circumstances of the farms on which they are reared. In the second winter they are fed in much the same manner as in the first, except that straw may be given for some months instead of hay; and in the third winter they have a greater allowance of corn, as they are frequently worked at the harrows in the ensuing spring. (*General Report of Scotland*, vol. iii. p. 183.) When about three years old, the author of the *New Farmer's Calendar* advises

foals to be fed all winter with a little corn twice a day, with hay, oat-straw, &c. Where carrots can be procured, they form a most excellent feed for colts of every age, on which they will thrive surprisingly. With the use of carrots, no corn is necessary, nor any caution requisite against an over-heating effect from a more stimulating diet. Care should, however, be taken to cut them properly, allowing a well littered shed, or warm straw-yard. Colts fed at home with green meat, cut during summer, should have a daily range on a common, or elsewhere, for exercise. Yearlings to be carefully kept separate from the milch mares.

6650. *The time for gelding colts* is usually the same in both parts of the kingdom, which is, when they are about a year old; although, in Yorkshire, this operation is frequently suspended till the spring of the second year, especially when it is intended to keep them on hand, and without employing them in labour till the following season. Parkinson disapproves of delaying this operation so long, and recommends twitching the colts, a practice well known to the ram-breeders, any time after a week old, or as soon after as the testicles are come down; and this method, he says, he has followed himself with great success. (*Parkinson on Live Stock*, vol. ii. p. 74.) Blaine's remarks on the subject of castration appear worthy of notice: he says, when the breed is particularly good, and considerable expectations are formed on the colt, it is always prudent to wait till twelve months: at this period, if his fore parts are correspondent with his hinder, proceed to castrate; but if he be not sufficiently well up before, or his neck be too long and thin, and his shoulders spare, he will assuredly improve by being allowed to remain whole six or eight months longer. Another writer suggests for experiment, the *spaying* of mares, thinking they would work better, and have more wind than geldings. (*Marshal's Yorkshire*, vol. ii. p. 169.) But he does not appear to have been aware that this is by no means a new experiment: for Tusser, who wrote in 1562, speaks of *gelding fillies* as a common practice at that period. The main objection to this operation is not that brood mares would become scarce, as he supposes, but that, by incapacitating them from breeding in case of accident, and in old age, the loss in this expensive species of live-stock would be greatly enhanced. An old or lame mare would then be as worthless as an old or lame gelding is at present.

6651. *The rearing of horses* is carried on in some places in so systematical a manner, as to combine the profit arising from the advance in the age of the animals, with that of a moderate degree of labour, before they are fit for the purposes to which they are ultimately destined. In the midland counties, the breeders sell them while yearlings, or perhaps, when foals; namely, at six or eighteen months old, but most generally the latter. They are mostly brought up by the graziers of Leicestershire, and the other grazing parts of the midland counties, where they are *grown* among the grazing-stock until the autumn following. At two years and a half old they are bought up by the arable farmers, or dealers of Buckinghamshire, Berkshire, Wiltshire, and other western counties, when they are broken into harness, and worked till they are five, or more generally, six years old. At this age the dealers buy them up again to be sent to London, where they are finally purchased for drays, carts, waggons, coaches, the army, or any other purpose for which they are found fit. (*Marshal's Economy of the Midland Counties*, vol. i. p. 311.)

6652. *In the west of Scotland, a similar mode of transferring horses* from hand to hand is common. The farmers of Ayrshire, and the counties adjacent, who generally grow corn on not more than one fourth, or at the most, one third of their arable land, and occupy the remainder with a dairy stock, purchase young horses at the fair of Lanark and Carnwath before mentioned; work them at the harrows in the following spring when below two years old; put them to the plough next winter, at the age of two and a half, and continue to work them gently till they are five years old, when they are sold again at the Rutherglen and Glasgow markets at a great advance of price, to dealers and farmers from the south-eastern counties. A considerable number of horses, however, are now bred in the Lothians, Berwickshire, and Roxburghshire, the very high prices of late having rendered it profitable to breed them, even upon good arable ground; but many farmers of these counties, instead of breeding, still prefer purchasing two and a half or three and a half year old colts, at the markets in the west country, or at Newcastle fair, in October: they buy in a certain number yearly, and sell an equal number of their work horses before they are so old as to lose much of their value. (*General Report of Scotland*, vol. iii. p. 182.)

SECT. XII. *Training of Horses.*

6653. *Horses are trained for various purposes*, but principally for carrying our persons or drawing our burdens. Formerly, burdens were principally borne on the back by pack-horses, but the improvements in our roads have removed them from the back, to machines called carriages, drawn by means of harness applied over the person of the horse. Under saddle, we train horses as racers, hunters, hackneys, or troop horses. In harness we use them in coaches, stages, chariots, and various lighter vehicles, or we employ them in waggons, carts, ploughs, and various other agricultural or commercial machines. Horses are held in obedience by means of bridles, with appendages called reins, which are long or short, as used in riding or driving. Horses are directed and urged forward by whip, spur, and language, and they are chastised by the same means.

6654. *The directive language used to horses* ought to be every where the same, which is the more easily accomplished, as words or phrases are sufficient for giving every requisite direction to a horse. The first of these words may be "on," or go on, or merely the common chuck of the tongue, &c. as used by all coachmen in the world; the second to make the horse go to the right-hand side, "right-hand;" the third, to the left-hand side, "left-hand;" the fourth to make them stop, may be "stop," or "stand-still." Any attempt to modify these directions ought to be given in the correct language of the country, and not in provincial words, as go on, slowly, briskly, right-hand, a little round, or turn, left-hand, a little, or left-hand and round, stop, or stand gently, &c. As a proof that only four words are requisite for giving every requisite direction to horses, we may mention that foreigners in Stockholm, Petersburg, and Moscow, who know nothing of the language, require only four corresponding words of Swedish or Russian to direct the native coachmen and sledge drivers to any street, house, or place, the situation of which they know by the maps, or otherwise.

6655. *The three natural and ordinary movements of horses* are, walking, trotting, and galloping, to which some horses naturally add another, which is known by the name of "ambling," or "pacing." The trot is, perhaps, the most natural motion of a horse, but the pace, and even the gallop, are most easy to the rider.

6656. *In training saddle horses*, the first thing is to make them familiar with man, and other general objects, and which is best effected at the earliest periods, which then saves almost all the trouble of breaking, and docility follows as a matter of course: to effect this, the greatest kindness should be used to the colts from the moment they are dropped: they should be accustomed to be handled, should be fed with bread, patted in various parts of the body, have light matters put on their heads and backs, and subjects of different colours and forms should be shown them with caution. While at foot, the mare and foal should be led out into roads, and where carriages pass, during which time nothing should be allowed to intimidate the foal. By this management, the animal will be easily prepared for the future operations; and it is thus that the single foal the ploughed-land farmer breeds, and which daily follows the mother in her work, as it were breaks itself.

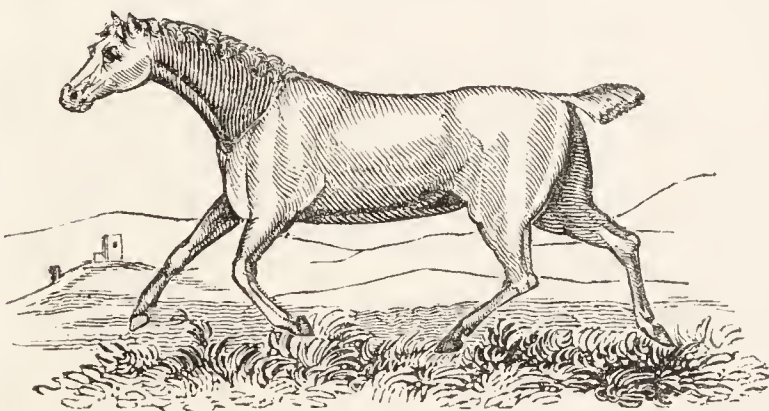
6657. *Backing* is the next operation, and if the colt has been judiciously used, and taught familiarity and docility by early handling and kindness, it is by no means difficult. It should be commenced before the colt is two and a half or three years old. The first backing of a horse is a thing of great consequence, as his value afterwards very much depends of it. The application of the saddle should be gradually done, and without alarm to the horse. After a colt has become habituated to the saddle and bridle, and has been exercised some time, morning and evening in them, and become somewhat obedient, it is usually

recommended that he be taken to some ploughed land, where he is to be walked and trotted until he be slightly fatigued. If the colt be very high spirited or refractory, or if he be not inclined to lift up his legs sufficiently, it may be admissible to practise him on some very light-ploughed lands; but if otherwise, it is better to dispense with this, and a field and a road alternately used will, in general cases, be found preferable. It would be well that this preliminary practice should be performed in a cavesson to ensure obedience. When he is perfectly tractable during his exercise, let a person used to him lay himself gently and by degrees across his back; and if he seem not to be alarmed, let him proceed at a foot-pace with his burden. When this occasions no alarm, let one leg gradually be slid over his back, the person at his head engaging his attention during the time, and encouraging him. The rider may then gradually raise himself up. The next step will be to mount him at once in the usual way, still having a judicious attendant at his head: this must likewise be done suddenly, or at a jerk, but very gradually and slowly, by several risings and heavings. If he bear this patiently, the person is to seat himself firmly on his back; but if he be troublesome and not tame enough, the person is to forbear the attempt to mount, and he is to be trotted in the hand over the same ploughed lands or other ground again, till he is more fatigued, and willing to receive the rider quietly on his back: when this is done, the person who is on his back must encourage him, and the man who has his head must lead him a few paces forward; all the while encouraging him. The feet are to be fitted well in the stirrups, and the toes turned out; afterwards the rider is to shrink and move himself in the saddle, and the person who holds his head is to withdraw his hand a little farther from the mouth. As the rider moves his toes forward, the holder must move him forward with the rein, till he is made to apprehend the rider's motion of body and foot, which must always go together, and with spirit, and will go forward without the other's assistance, and stay upon the restraint of the rider's hands. When this is accomplished, let him be cherished, and again have grass and bread to eat; and then let the rider mount and alight several times, encouraging him between each time, and thus he is to be managed till he will go on, or stand still at pleasure. This being done, the long rein may be laid aside, and the band about the neck, which are always used on this occasion, and nothing will be necessary but the trenches and cavesson, with the martingal. A groom must lead the way before; or another horse going only straight forwards, and making him stand still when desired. In this manner, by sometimes following, and sometimes going before another horse on the trot, the creature will by degrees be brought to know that it is his business to be quiet and governable.

6658. To teach a horse the different movements of walking, trotting, galloping, and ambling, comes next in order.

6659. *Walking* is the slowest and least raised of all a horse's movements. It is performed, as any one may observe, by the horse's lifting up its two legs on a side, the one after the other, beginning with the hind leg first. Thus, if he leads with the legs of the right side, then the first foot he lifts is the far hind foot; and in the time he is setting it down (which in a step is always short of the tread of his fore foot on the same side) he lifts his far fore foot, and sets it down before his near fore foot. Again, just as he is setting down his far fore foot, he lifts up his near hind foot, and sets it down again just short of his near fore foot; and just as he is setting it down, he lifts his near fore foot, and sets it down beyond his far fore foot. This is the true motion of a horse's legs in a walk; and this is the pace in which many things are best taught; for instance, when the horse is to be taught to turn to the right and left, or from one hand to another, he is first to be taught it on the walk, then on the trot, and finally on the gallop. The walk is a pace to which team, carriage, and road horses should constantly be well broke, as being of great use in all such cases and intentions. It is an excellent pace too in a saddle horse, when well performed by being properly taught.

6660. In *trotting*, the limbs are diagonally employed; but their tenses or times, or rising and falling, are very different, as it is conducted slow or fast. In the slow trot the diagonal legs are elevated and replaced simultaneously; while those on the ground are preparing to elevate themselves, and the horse is for a moment on tiptoe; but until the original diagonal legs are set down, these are not wholly elevated: therefore the horse is during the moderate trot at no time without support. But it is very different when the trot is accelerated, as to nine or ten miles an hour; for then there is a period in every spring made by the



diagonal members, when all the feet are in the air at the same time; and the body completely suspended from the ground by these means. Thus during this accelerated action, the off fore leg and near hind leg having been elevated in the air, before they meet the ground, the near fore leg and the off hind one are not only prepared, as in the slow trot, to elevate themselves, but actually do so before the others are set down; consequently, the feet, at this precise time, must be all in air. (fig. 846.) To speed in the trot, it is necessary that a horse pick up his feet quick, and extend them far forward. To the safety also, it is necessary he elevate his knee particularly; at the same time the general

elevation of the whole limb is operated by high withers and oblique shoulders.

6661. *Three qualities are essentially necessary to make the trot useful.* It ought to be extended, supple, and even, or equal: these three qualities mutually depend upon each other, so that you cannot pass to the supple trot without having first worked upon the extended trot; and you can never arrive at the even and equal trot without having practised the supple. The *extended trot* (fig. 846.) is that in which the horse trots out without retaining himself, going directly forwards; and this consequently is the kind of trot with which you must begin. The *supple* trot is that in which the horse, at every motion he makes, bends and plays his joints by the elasticity of the organs composing them; which no colts or raw horses can execute, who have not had their limbs suppled by exercise. The *even* or *equal* trot is that in which the horse moves so equally and exactly, that his legs never cover more ground one than the other nor at one time more than another. To go from the extended trot to the supple, you must gently and by degrees hold in your horse; and when by exercise he has attained sufficient ease and suppleness to manage his limbs readily, you must insensibly hold him in still more and more, and by degrees you will lead him to the equal trot.

6662. *The manner of trotting a colt who has never been backed* is as follows:—Put a plain snaffle in his mouth; fit a cavesson to his nose, to the ring of which tie a longe of a reasonable length. Let a groom hold this longe, who having got at some distance from the colt, must stand still in the middle of the circle which the horse will make. Let another follow him with a long whip or chambrière in his hand. The cold being alarmed, will be forced to go forward, and to turn within the length of the cord, the groom must hold it tight in his hand; by this means he will draw in, or towards the centre, the head of the colt, and his croupe will of consequence be without the circle. In working a young horse after this manner do not press or hurry him. Let him walk first, and afterwards put him to the trot. If you neglect this method his legs will be embarrassed: he will lean on one side, and be more upon one haunch than the other; the inner fore foot will strike against the outer one, and the pain which this will occasion will drive him to seek some means of defence, and make him disobedient. If he refuses to trot, the person who holds

the chambrière will animate him by trotting him, or striking the ground with it. If he offers to gallop instead of trotting, the groom must shake or jerk the cord that is tied to the cavesson, and he will fall into his trot. (*Berenger's Art of Horsemanship*, vol. i. chap. 4.) The value of this longing in a circle is incalculable, inasmuch as it supple the shoulders, and gives them a greater extent of action. It also increases the action of the whole limb downwards, and accustoms the horse to effect other movements, to be performed with an elevated hand.

6663. *The gallop* is the swiftest natural pace of a horse, in which the two fore feet become elevated almost at the same moment, but one slightly takes the lead of the other, and must therefore be set down beyond and somewhat after it: previous to this, however, the hinder legs have become elevated, with also a little precedence in the leg of that side which has been led by the fore. Such is the natural gallop of the horse; when it is performed with its utmost velocity the limbs are simultaneous and synchronous. (6664.) In galloping the horse may lead with which fore leg he pleases; the most usual way is that with the right, in which case the gallop is said to be *just*; but whichever it be, the hind leg of the same side must follow it next, which forms an even or equal gallop; otherwise the legs are said to be disunited, and the gallop to be *false*; to remedy which disorder, the rider must stay the horse a little on the hand, and help him on the spur on the contrary side to that on which he is disunited. However, this rule has not been always strictly observed; for hunting horses have been trained to lead indifferently with both legs, because it has been found, that a horse which has never been suffered to gallop but with his right fore leg, has been worn out on one side, when he has been fresh and sound on the other. In order to make a stop in a gallop straight forwards, the rider should carefully put his horse together, without altering or disturbing the appui, and throw his body back a little to accompany the action, and to relieve the horse's shoulders. In doing this he should seize the time of making the stop, keeping the hand and body quite still, exactly when he feels the horse put his fore feet to the ground, in order that by raising them immediately by the next motion which he makes, he may be upon his haunches. When horses do not answer to the lessons in the gallop, they should be galloped briskly, and then slowly again by turns, and they will thus be compelled to obey the hand and heel. In the slow gallop, as well as in the trot, it is sometimes necessary to close the heels to the horse's sides, which is called *pinching*; but this should be done in such a manner as not to make the horse abandon himself upon the hand, and care must be taken that he be upon his haunches, and not upon his shoulders; and therefore, when he is pinched, he should be kept in the hand. To put a horse well together, and make him bring his hinder legs under him, the rider must close his legs upon him, putting them very much back; this will oblige him to slide his legs under him; at the same instant let the hand be raised a little to support him before, and yielding again immediately. Let him be thus supported, and have the rein again from time to time, till he begins to play and bend his haunches, and gallops leaning and sitting down, as it were, upon them; let the rider then press him with the calves of his legs, and he will thus become quick and sensible to the touch. If a horse has too fine a mouth, gallop him upon sloping ground; this will oblige him to lean a little upon the hand, in order the better to put himself upon the haunches; and through fear of hurting his bars, he will be prevented from resisting the operation of the bit. If the horse is heavy in hand, gallop him up sloping ground; and when his appui is too strong, this will lighten him. The gallop serves to assure and make steady a weak and delicate mouth, and also to supple a horse, and make him steady and active in his limbs. (*Berenger's History and Art of Horsemanship*, vol. ii. p. 104., &c.) In galloping in a circle, the horse is confined always to lead with his fore leg within the turn; otherwise he is said to gallop *false*.

6664. *The varieties of gallop* may be reduced to the *gallop of speed*, the ordinary or *hand gallop*, and the *canter*: all others are but compounds of these. The *gallop of full speed* is the most simple of all the paces, being nothing more than a succession of leaps; but it requires repeated efforts to acquire its full celerity: the fore parts being first raised and thrown forwards are followed by the hinder immediately; as the velocity increases, the fore and the hind legs become opposed to the ground at almost the same instant, thus forming a repetition of leaps. The *ordinary or hand gallop* does not differ from the gallop (6663.), except that the leading leg being elevated still earlier, and being carried still more forward, is followed also by an earlier and a more considerable displacement of its fellow leg behind, which of course retards the velocity considerably, and lessens the exertion. The school gallop is formed of this, with the haunches drawn more under, and the fore hand more thrown up.

6665. *The canter is different from the gallop* in some essential particulars. Whether the gallop be fast or slow, still the legs are at one period wholly removed from the ground, and the horse is all in air. In the canter, on the contrary, at no period is the horse completely elevated from the ground, but has always one or more points of contact with it. Blaine describes its operation thus:—When performed on the right, the horse commences by first placing his off hind leg a little beyond the other; at nearly the same instant he elevates the fore hand, and places first the near fore leg on the ground; the off doubling over and beyond, is placed in an instant after it. In the next movement the hind legs are thrown in, and, while elevated, the off fore leg becomes raised from the ground; but the near fore leg is not elevated until the hinder ones are replaced. The near fore leg is, therefore, the whole point of support in cantering at each remove, and thus it is that cantering horses always first fail on that leg.

6666. *The amble* is a peculiar kind of pace, by which the horse changes sides at each remove; two legs of a side being always in the air, and two on the ground. An amble is usually the first natural pace of young colts, which, as soon as they have strength enough to trot, they quit. There is no such thing as an amble in the modern manege; the riding-masters allowing of no other paces besides walk, trot, and gallop; their reason is, that a horse may be put from a trot to a gallop, without stopping him; but not from an amble to a gallop without stopping.

6667. *The training of cavalry horses* is exclusively performed in the military establishments, and therefore can never be required of the farmer or breeder.

6668. *The training of coach horses* commences with taming, walking, trotting, and repeated longing; and next with yoking and driving in a break or four-wheeled frame, with no other load than that of the coach box or seat placed in the usual position, the driver and his assistant sitting on a board fixed to the perch or hind axle, in order to be ready at a moment's notice to descend and restrain or direct the horses. Coach horses, from fifteen to sixteen hands high, should walk light five miles an hour, and trot twelve. They should be first accustomed to this exercise in the country, next in the outskirts of a large city, and lastly in the most crowded streets.

6669. *The age at which a horse is fit to be worked in a coach* is four and a half or five years; but by the fraudulent practice both of the country and town dealers, horses of three and four years old are frequently employed. The first business of the Yorkshire dealer, who has three or four years old colts to dispose of, is to draw their corner teeth, in order to make them have the mouths of those of five. They also undergo the operation of docking and nicking; and after having been kept two or three months on mashes, made of bran, ground oats, or boiled corn, they are sold to the London dealers, who, it is said, sell these three or four years old horses as if they were five years old. They are then taken into immediate work, either for the coach or saddle; and in a few months are completely destroyed by this premature and too severe labour. The drawing of the teeth is not a fraud practised on the London dealers; they *know* the deception, and *insist* upon its being done by the country dealers. It is requisite to be done some months before the London dealers finally sell them for use, or the tooth which denotes a horse to be five years old would not be grown, consequently the deception could not have taken place.

6670. *The training of cart and plough horses* commences with taming before they are a year old, with walking and rubbing them down in the stable when they are two, and with training to work when they are of three years' growth. They should be placed under the charge of a very steady careful servant, who

will teach them to back, and to go into the shafts. They ought not, however, to be made to draw any other than a very light empty cart till their fourth or fifth year; nor ought they to be put into the shafts of a threshing machine before their fifth year. The first work to which an agricultural horse may be applied is harrowing; but this during the fourth year only half a day at a time, or with a light harrow the whole day. Next he may be put to plough with similar care and caution in regard to strength. In general, agricultural horses require very little training; but one thing is too often neglected, and that is, teaching plough horses a quick step, and keeping them at that step ever after in working them. By not attending to this, and leaving the step to be regulated by lazy spiritless ploughmen, the loss to many farmers is very considerable.

SECT. XIII. *The Art of Horsemanship.*

6671. *Horsemanship, as an art*, is unquestionably of very ancient date, and it is curious how very different are the modes by which it is practised in different countries; but which differences are yet principally confined to the situation of the legs of the rider; for wherever the horse is used to carry the person, it is by the rider placing himself astride the animal. Horses were used in this way for centuries before any apparatus was used or applied to their bodies to spare fatigue to the rider; and we know that the first saddles were mere pads strapped round the body, but without the appendages of stirrups. In England, riding is systematically divided into two kinds, which are manege and jockey riding.

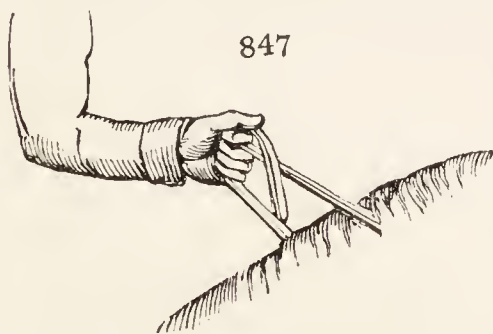
6672. *Manege riding*, called also *riding the great horse*, in the strict application of the term, was formerly more practised than at present; and required a system of education for both horse and rider long and severe. Horses perfectly broke for the manege were formerly taught several paces and motions, as ambling, pacing, passaging, yerking, capriole, and cornetti. The practice of these artificial cadences, it is supposed, injures the natural pace of the horse; and this circumstance, united to a particular form of horse (defective for other purposes) being required for the elasticity of these actions, has tended to bring manege riding, as formerly practised, into disrepute. Manege riding also taught the constant application of the seat of the body of the rider to the seat of the saddle, during all the motions of the horse; and as a severe education, and a particular form, had bestowed ease and elasticity to the rudeness of the manege horse, the inconveniences of this seat were not felt. But when another form of horse, capable of great speed over excellent roads, was in general use, this kind of riding was found hurtful to both horse and rider; fatiguing the one, and injuring the other.

6673. *The art of proper riding*, as practised among experienced horsemen, is derived from a knowledge of the judicious application of the aids of the bridle, as taught in our schools, and as practised in the army generally; and also from a proper application or placing the body on the horse. These we certainly owe to manege riding; and a knowledge of them is as essential to the safety of the rider, as it is to the grace of his appearance as a horseman. The proper art of riding embraces all that is taught in the best schools, or practised on the road; and is equally applicable to both. This is allowed to its fullest extent by those who have possessed themselves of the requisite information and practice on the subject; but is denied by those who, wedded to field riding, contend that the perfection of horsemanship consists in a snaffle bridle and a jockey seat.

6674. *The use of the curb bridle* is considered in the schools to be essential to good riding: by it the horse is not only restrained, but he is also aided and assisted. He is alternately thrown on his haunches, or forced on his forehead, by which changes fatigue is prevented to both. Great nicety, however, is required in the use of the curb; and without an inclination and ability to use it lightly and dexterously, a snaffle is the best and safest bridle. The curb is to be operated by a gentle turn of the wrist only; and the action of the hand in this respect should be as fine and as pliable as the fishing rod and line. The force of the curb should in every instance be proportioned to the mouth of the horse.

6675. *The best form of saddle* for general riding is one in which the cantle is not so high as the military, nor so low as the racing saddle. The pommel should be no more raised than is necessary to keep the whole completely free from the withers. The stirrups should be substantial, not only to prevent breaking, but also that by their weight they may fall to the foot when accidentally slipped away; which is of more consequence than at first sight may appear. If they are of the spring kind, it is also desirable: but it is still more so, that the spring stirrup leather should be used; which prevents the danger arising from horses catching the leather in the projections of doors, gates, &c. Having saddled and bridled our horse, we will proceed to mount our rider.

6676. *If you would mount with ease and safety*, says Hughes, stand rather before the stirrup than behind it; then, with the left hand, take the bridle short, and the mane together, help yourself into the stirrup, with your right, so that, in mounting, your toe do not touch the horse. Your foot being in the stirrup raise yourself till you face the side of the horse, and look directly across the saddle; then, with your right hand, lay hold of the hinder part of the saddle, and, with your left, lift yourself into it. When mounted, let your position on the saddle be square, and the purchase of your bridle such as not to pull your shoulders: and let your body be in such an even posture as if you held a rein in each hand. In



holding the bridle, grasp the reins with your hand, which should be held perpendicular with the reins passed, the lower within the hand, and the upper between the fore and next fingers (*fig. 847.*). The reins are then brought over the fore finger and firmly held by the thumb. It is often directed to place the little finger between the lower reins; the practice of this may be optional with the rider, and in a very fine hand is desirable. The bridle should be held at such a length as to enable you if your horse stumbles, to raise his head and support it with your arms; and by throwing your body backwards at the same time you frequently save a horse that would otherwise fall.

6677. *A graceful and proper seat* on horseback is greatly dependent on a right disposition of the legs and thighs, which should hang nearly straight down, easily, and without force or constraint: all which is brought about from above; by placing the body flat and evenly on the saddle, and opening the knees, whereby the fork will come lower on the saddle. (*fig. 848.*) The thighs should be applied to the saddle and to the sides of the horse by their inner surfaces, so as to bring in the knees and toes; and although the line may be properly broken by some little irregularities, yet the foot, the knee, the hip, and shoulder, should deviate but little from one perpendicular line. The ball of the foot should rest within the stirrup, and should be even with the heel, or very slightly elevated above it. Avoid any stiffness in the legs, thighs, or body; all should be lax, but in a state to be able to embrace the horse, either for support, or as aids to him. The loins, particularly, should be lax and pliable, as a coachman's on his box; and for the same reasons: for by sitting thus loosely, the rough motions of both are broken. To depend on the embrace of the knees for support is to lose the benefit of a true equipoise of body, and is rather to stick on a horse than to sit on one.



6678. *When you are troubled with a horse that is vicious*, which stops short, or, by rising or kicking, endeavours to throw you off, you must not bend your body forward, as is commonly practised in such cases; because that motion throws the breech backward, and moves you from your fork, or twists and casts you out of your seat; but the right way to keep your seat, or to

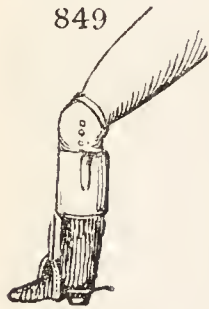
recover it when lost, is to advance the lower part of your body, and to bend back your shoulders and upper part. In flying or standing leaps, a horseman's best security is the bending back of the body. The rising of the horse does not affect the rider's seat; he is chiefly to guard against the lash of the animal's hind legs, which is best done by inclining the body backwards. But the usual method of fixing the knees in all cases of danger only serves, in great shocks, to assist the violence of the fall. To save yourself from being hurt, in these cases, you must yield a little to the horse's motion; by which means you will recover your seat, if displaced, or keep it at such times as would dismount an unskilful horseman.

6679. *If your horse grows unruly*, take the reins separately, one in each hand, put your arms forward, and hold him short, but do not pull hard with your arms low; for, by lowering his head, he has the more liberty to throw out his heels: but if you raise his head as high as you can, this will prevent him from rising behind. Is it not reasonable to imagine, that, if a horse is forced towards a carriage which he has started at, he will think he is obliged to attack or run against it? Can it be imagined that the rider's spurring him on, with his face directly to it, he should understand as a sign to pass it? These rational queries are submitted to the serious consideration of such as are fond of always obliging their horses to touch those objects at which they are, or affect to be, frightened.

6680. *Indifferent horsemen*, Lawrence observes, should never venture on horseback without spurs. Those who reflect upon the predicament of being placed between a deep ditch and a carriage, at which their horse shies, will see the necessity of this precaution.

6681. *Previously to mounting*, every person will find his account in examining the state of both horse and furniture with his own eyes and hands; for, however good and careful his groom may generally be, it is a maxim, that too much ought not to be expected from the head of him who labours with his hands. Besides, all such sedulously avoid trouble, particularly in nice matters. For example, see that your curb is right; that your reins are not twisted; that your girths, one over the other, still bear exactly alike; that the pad be not wrinkled up; but, above all, that your saddle lies exactly level upon the horse's back.

6682. *On getting off the horse's back*, hold the bridle and mane in the same manner as when you mounted, hold the pommel of the saddle with your right-hand; to raise yourself, bring your right leg over the horse's back, let your right-hand hold the hind part of the saddle, and stand a moment on your stirrup, just as when you mounted. But beware that, in dismounting, you bend not your right knee, lest the horse should be touched by the spur.



6683. *The jockey mode of riding* is practised in its fullest extent in racing. With some modification it is also in use by many who esteem themselves excellent fox-hunters. With still greater modification it is by its advocates practised also on the road. English post-boys unite these two kinds of riding in a manner at once easy to themselves and horses. True jockey riding consists in the use of a snaffle bridle, which is held firmly; and, as an advocate for it expresses himself, to enable the rider to give his horse the proper pulls. To this end, the same writer recommends a firm seat, upright, and as you would sit in a chair, with the knees nearly as much bent, and turned inward; the toes somewhat out and upward; the leg falling nearly straight, and the foot home in the stirrup (*fig. 849.*); elbows close to the sides; hands rather above the horse's withers, or pommel of the saddle; and the view directed between his ears. The same writer further advocates the jockey mode, by commenting on the decline of riding-house forms, and the universal preference given to expedition, which, as he says, fully confirm the superior use and propriety of a jockey-seat. Indeed, our riding-

schools are now, he continues, considerably reformed from the stiffness of ancient practice in all respects. It was the custom formerly in the schools, and indeed pretty generally upon the road, to ride with the tip of the toe only in the stirrup; as if it were of more consequence to prepare for falling with safety, than to endeavour to sit securely. Those who preserve a partiality for this venerable custom, we would advise to suspend a final judgment, until they have made a few more essays upon a huge cock-tail half-bred, of that kind which 'cannot go, and yet won't stand still,' and will dart from one side of the road to the other, as if he really desired to get rid of his burden. Nor is the ball of the foot a proper rest; chiefly because inconvenient to that erect, or rather almost kneeling, posture, which is required in speedy riding. The riding-house seat is preserved by the balance or equipoise of the body solely; that recommended here by the firm hold of the knee, which is obviously strengthened by the opposite directions of the knee and toe, the one in, the other outward.

SECT. XIV. *Feeding of Horses.*

6684. *The feeding of horses generally* is an important feature in their management. In considering the food for horses, we are apt to locate our notions to the matters around us, without taking into account that every country has its peculiar products. White observes, that the best food for horses is hay and oats; and had he added for English horses, it might have been just, but without such notice the assertion is much too confined. "In some sterile countries, horses are forced to subsist on dried fish, and even vegetable mould; in Arabia, on milk, flesh balls, eggs, broth, &c. In India, horses are variously fed. The native grasses I judge very nutritious. Few, perhaps no oats are grown in India. Barley is not commonly given to horses; indeed, it is rarely grown. In Persia, barley is a common food for good horses. In some parts of India (in the Mahratta country), salt, pepper, and other spices are made up into balls, as big as billiard balls, with flour and butter, and thrust down the animal's throat. It is supposed to give them animation and fine coats: no doubt it promotes digestion. Meat broth (especially sheep's head) is also given to horses. English gentlemen sometimes adopt these usages. Different kinds of grain are given to horses in different parts of India. In Bengal, a vetch, something like the tare, is used. On the western side of India, a sort of pigeon pea, called gram (*Cicer arietinum L.*), is the usual food; with grass in the season, and hay all the year. Indian corn or rice is, I think, seldom if ever given to horses in India as ordinary food. In the West Indies they are fed on maize, Guinea corn, and sugar-cane tops; and, in some instances, on the sugar itself, in the form of molasses. In France, Spain, and Italy, besides the grasses, the leaves of limes, vines, the tops of acacia, the seeds of the earob tree, &c. are used."

6685. *The food of British horses* may be divided into herbage, grain, roots, and mixtures. Of *herbage*, the principal kind is the proper gramina, eaten either moist or dried into hay. When eaten moist in their natural state, such a horse is said to *graze*; but when these matters are cut, and carried into the stable to a horse, he is said to be *soiled*. Hay is herbage cut during its flowering and seeding processes; which being subjected to the action of the sun and air a proper time, are then collected into large masses called ricks, where a certain degree of fermentation takes place before the matter is fitted to become wholesome or nutritious, or before it receives such alteration as fits it for resisting further decomposition and decay. The judicious management of this fermentative process forms one of the greatest desiderata in hay-making. Pursued to a proper extent, the remaining moisture acting on the farinaceous parts, as the seeds, &c., in conjunction with the heat evolved during the process, as it were malts the whole, and sugar is produced. Pushed beyond this, the hay becomes carbonised, and mow-burnt; its nutritive properties are lessened, and its noxious qualities increased, it being found in this state to excite diabetes, sweating, and extreme weakness and emaciation. (6425.) The quality of the hay is too little attended to, but which is of very great importance; and more particularly so where little corn but much hay is given. Hay should therefore be of the best, whether meadow, clover, or mixed. Many horses thrive best on clover hay, particularly draught horses. It is very grateful to horses, and it saves much waste of saliva; to sprinkle hay with water has the same effect, but it should only be done as it is wanted.

6686. *Hay should never be given in large quantities at a time* ; horses breathe on it, become disgusted, and then waste it. They also, when it is good, eat too much, and distend their stomachs, and then become crib-biters. Hay should not be kept in the stable in great quantities, otherwise it becomes impregnated with the volatile alkali of the stable, and is then spoiled. As substitutes for hay, the straw of wheat, barley, oats, and rye are used ; but these are much less nutritive, and rather serve to excite mastication by mixing them with other matters, than to be depended on for animalisation. On hay, when good, many horses subsist ; and when no exertions are required of them they are sufficiently nourished by it.

6687. *The grain used as horse food* is of various kinds, possessing, it is supposed, different degrees of nutriment, according to their different proportions of gluten, sugar, or farinaceous matter. In South Britain, oats are almost exclusively used as horse grain ; and which, according to the experiments of Sir Humphry Davy, as we have seen (§ 5000.), contain 748 parts of nutritious matter out of 1000. In wheat, 955 parts of 1000 are nutritious ; but wheat is seldom given with us except to racers and hunters, or on extraordinary occasions when great excitement is required, when it is sometimes given in the form of bread. Barley is more frequently given than wheat, and contains 920 parts in 1000 of nutritious particles. Made into malt, where its sugar is evolved, it becomes still more highly nutritious. Barley appears to have been the principal horse food of the ancients.

6688. *The pulse used as horse food*, are the seeds of beans, peas, vetches, &c. Beans are seldom given alone on account of their heating and astringent qualities, but are mixed with straw or hay, cut into chaff, either whole or broken.

6689. *The roots used as horse food*, are such as contain much sugar, but in which the gluten is in small proportion only. Carrots stand deservedly high on this list. They are favourable to condition, as the skin and hair always look well under their use. They are highly nutritious we know, from the fattening that occurs from them. They also generate good flesh, as we know horses can work on them, and have their wind increased by their use ; indeed, so favourable are they to the proper action of the lungs, that a course of carrots will frequently remove the most obstinate coughs. The parsnep has similar properties. Swedish turnips, as having the saccharine particles in abundance, are also found good. Beet-root likewise.

6690. *Mixtures, or mixed food*, is formed of several kinds among agriculturists ; and it possesses many advantages, as it can be varied to every taste, and made either cooling as an alterative, or nutritious and stimulating as a tonic. Although it is principally used for waggon, post, and farm horses, it would be better were its use more universal. Of this manger feeding, one of the best is formed from a chaff made of one part best meadow or clover hay, and two parts wheaten straw ; to three bushels of this mixture add one of bruised oats. The importance of bruising or flattening the oats is very great. When used whole, the grains are apt to slip between the teeth or the chaff in mastication. In fact, corn when either given alone, or with chaff, would, in most instances, benefit by bruising. To horses under great exertion, the stomach must be, to a certain degree, weakened also ; in such cases, by bruising their corn, not only the work of mastication is much of it spared, but that of the stomach also. In old horses with worn teeth, bruised oats are of great consequence. Fast-eating horses do not properly masticate more than one half of their corn ; much of it remains in the dung so perfectly unaltered, that it will afterwards vegetate ; and an experienced agriculturist states, that during his residence in India, in a season of scarcity, half-famished wretches actually followed the cavalry, and drew their principal subsistence from the unchewed grains of corn extracted from the excrement of the horses. Of this manger food, three, four, five, or six pecks may be given daily, according to size and exertions required ; and as but little hay is required, so hard-worked horses are enabled to lie down much more, instead of standing on their already fatigued limbs to eat hay.

6691. *Cooked food* is also now much used by practical agriculturists for horses. The articles made use of are potatoes, carrots, turnips, or parsneps. To horses with their digestion weakened by hard work, old age, or other causes, food in sufficient quantities, thus already reduced to a pulvaceous mass, resembling chyme, without the loss of time, or the waste of saliva, may be very important : for, as Curwen very judiciously observes, a horse will consume nearly six hours in eating a stone of hay, whereas he will eat a stone of steamed potatoes in twenty minutes. Horses are observed of themselves to lie down after eating cooked food sooner than other times.

6692. *The quantity of food* to be given to a horse must be regulated by circumstances, the principle of which is the exertions or nature of the work required of him. If this be simply laborious, as drawing of loads, or carrying of weights, all that is requisite is that the food be sufficiently nutritious. The bulk from whence such nutriment is gained is not a matter of import : but if such exertions are to be combined with celerity, as in our racers, hunters, &c., it is evident that such feeding is best adapted to the end required which combines nutriment without bulk ; and which increases the durability by increasing the mental irritability, and thus giving tone and courage. These are found to be better derived from a proportionate allowance of grain or corn, than any other mode of feeding at present known. It remains only to add, that although experience has fully proved this, in all cases where the exertions are extreme, yet it has also led to another evil, by introducing a plan of treating all horses of value alike. Thus, most of the more valuable hackneys, the carriage horses of the wealthy, &c., are accustomed to be fed, not as though their exertions were moderate, but as though they were unceasing, to the destruction of a vast quantity of valuable corn. From thousands of such horses, at least one third of their hay and corn might be advantageously abstracted.

6693. *Too great a quantity of food* injures not only the community but the horse also. The stomach becomes distended by over-feeding, and it then becomes weak and incapable of a healthy digestion ; crib-biting, hide-bound, and porsiveness follow ; or when the stomach does digest this undue quantity, it generate fulness, which shows itself in inflammations or foulness, appearing in the form of cracks and grease.

6694. *A horse in full work*, of whatever kind, will require, according to his size, a peck of sound oats in twenty-four hours ; and when the work is unremitting, as in post, stage-waggon, or other very large and hard-working horses, even more may be required. Some post horses have an unlimited quantity given them ; but this practice is always erroneous. If they eat more, it serves only to distend the stomach unduly, and also to require stronger digestive powers : if they blow on it they leave it, and it is wasted, or a more greedy one swallows it up without mastication ; and both stomach, horse, and master are thereby robbed. It is of consequence that the oats, as an important part of horse food, should be perfectly sweet, free from must, and not kiln-dried. The skin should be thin, but the grain plump and heavy, yielding from thirty-eight to forty pounds the bushel. To encourage a slow and thorough mastication, sprinkle them with water and spread them well over the manger. The quantity of hay required for saddle horses which are corn-fed is from six to eight pounds in twenty-four hours : if the quantity of corn be small, and the horse large, ten or twelve pounds is not too much. This quantity is also sufficient for carriage or coach horses, as they usually have either corn or mixed food in sufficient plenty also. For waggon and the larger agricultural horses, from fifteen to twenty pounds may be requisite. When it can be conveniently done, the quantity of both hay and corn should be divided into four portions. The largest portion both of hay and corn should be given at night ; the next in quantity in the morning ; the other two portions at noon, and about four in the afternoon. This, however, must depend on the work of the horse, and other circumstances.

6695. *Watering of horses* is an important part of their management, and many errors are committed relative to it. It is equally erroneous to debar them from it, as it is to allow them too much ; and the former is much the most common evil. In summer, or when from great perspiration the animal juices

are wasted, it generates fevers, and wastes the strength and spirits. All horses prefer soft water, and as nature is unerring, there is no doubt but that it is the most wholesome. As some horses drink quicker than others, it is not a good custom to take riding horses to a pond, unless at night, when the quantity cannot injure them; or when not intended for early work the next morning, as hunting, &c.

6696. *The necessary quantity of water* for a horse should be regulated by circumstances, as the weather, the work, &c. In common cases, a large horse requires rather more than the half of a large stable pail full twice in the day. At night a full pail should be allowed. Horses should never be galloped after drinking; it has destroyed thousands, by gripes, inflammations, and broken wind. This custom also uses horses to expect they are to run away directly they are accidentally watered at any time. Others, expecting they are to be fatigued with a gallop, will avoid drinking at all. The most that should ever be done, is to suffer no horse to drink his fill at a river or pond; but having given him half what is necessary, walk him ten minutes, and then give him all that is required, and walk him again.

SECT. XV. *Stabling and Grooming of Horses.*

6697. *The stabling of horses* is likewise a most important point in their management, the more so as being wholly a deviation from nature; hence, under the most judicious management, it is liable to produce some departure from health; and as sometimes managed, is most hurtful to it. Clothing, dressing, or combing, and exercise, are also highly important.

6698. *Every stable should be large, cool, and airy.* It is too common to suppose that warmth is so congenial to horses, that they cannot be kept too hot; but there is reason to suppose that many of the diseases of horses are attributable to the enervating effects of unnatural heat, and of an air breathed and rebreathed over again. Blaine says, Is it not alike repugnant to reason and experience, to expect to keep animals in health, that from stables heated to sixty degrees, and further protected by warm clothing, are first stripped, and then at once exposed to a temperature at the freezing point? If it be argued that habit and exercise render these less hurtful, it will be easy to answer that their original hardihood is lost by confinement and artificial treatment; and that neither does exercise always tend to obviate the effects of this sudden change: for our best carriage horses, and hackneys also, have often to wait hours in roads and streets the convenience of their owners, or the pleasure of the groom.

6699. *The heat of a stable* should be regulated by a thermometer, and the heat shown by it should never exceed 50° of Fahrenheit in winter, or 62° or 63° in summer. To renew the air, the stable should be well ventilated; and which is best done by trunks or tubes passing from the ceiling through the roof.

6700. *A stable should not only be well ventilated, but it should be light also;* and the windows should be so constructed as to admit light and air, without producing a current of wind on the bodies of the horses. Darkened stables are very hurtful to the eyes; neither do they, as was formerly supposed at Newmarket, tend to the condition or rest of a horse.

6701. *A stable should have a close ceiling* to keep the dust and dirt from the hay-loft from entering the horse's eyes. It is also necessary to prevent the ammoniacal gases from ascending and lodging in the hay. It is preferable that the hay-loft be altogether removed from over the stable; and if a very high ceiling even to the roof were substituted, it would be for the benefit of the horses.

6702. *The form of the rack and manger* should be attended to. Sloping racks are disadvantageous, as encouraging dust in the eyes. They should therefore be upright, and by no means so high as they usually are, by which the head and neck are put injuriously on the stretch. As a proof that this is unpleasant to horses, many of them first pull out all the hay, and then leisurely eat it. The manger should be wide at the bottom, and of a proper height: care should be taken that no splinters are present to endanger the lips, nose, and mouth. The halter reins should, in good stables, be suffered to run within a groove within the manger post, to prevent the rein entangling the legs. It is become the practice in some stables appropriated to post, stage-waggon, and other hard-worked horses, to abandon hay-racks altogether; but the hay being placed on the ground before the horse encourages him to lie down and eat it; by which much rest is afforded to the weary limbs, and much improvement to the feet.

6703. *The stalls of a stable should be wide.* Strains in the back, and sometimes even worse evils, are the consequence of the standings being too narrow. Bails are objectionable from the ease with which horses can kick over them; and also from the quickest feeder getting most food, when several horses stand together bailed.

6704. *The acclivity of the stalls* is a matter of much dispute: when too much raised, as in dealers' stables, they put the back sinews on the stretch, and fatigue horses much. It is more natural that they should be even; or that a very slight slope only be allowed to carry off the urine. The best mode, however, of carrying off the urine is by means of a small grating to each stall, communicating with a cess-pool without doors, which should be closed up, that a current of air may not come through the grating. Such a contrivance will effectually carry off the water, and prevent the volatile alkali of the urine from impregnating the air around. For the same reasons, the dung should be removed, if possible, wholly without the stable as soon as dropped; for the exhalations from that are also ammoniacal, and consequently hurtful. To this cause alone we may attribute many diseases, particularly the great tendency stabled horses have to become affected in the eyes. The pungency of this effluvia is familiar to every one on entering a close stable in the morning, and when the long-soiled litter is removed, it is absolutely unbearable.

6705. *The litter of horses* should be kept dry and sweet, and should be often removed. When it is suffered to remain, under the notion of making better dung, the horse may be ruined; neither does the manure benefit as is supposed; for when it is removed to the dung pit, the close confinement does it more good than the open exposure in the stable, when it parts with its salts, on which its properties as manure partly depend.

6706. *Horses should not stand on litter* during the day, although very generally suffered to do so. Litter is thought to save the shoes and even the feet, by preventing the uneven surface of the stable from hurting them: but it holds the urine; it injures the feet; and is very apt to encourage swelling at the heels: as we know by removing it, when they immediately subside. A little litter may be strewed behind to obviate the effect of kicking, or the splashing of urine in mares.

6707. *The clothing of horses* is apt to be carried to as erroneous an extent as the heat of their stables. When horses go out in cold weather, and are intended to have merely a long walking exercise, then clothing is very proper: but it must be evident, that when taken clothed from a stable and exercised briskly so as to produce perspiration, it is erroneous; for not only are the clothes wetted and thus liable to give cold, but the horse is unfitted to go out afterwards with a saddle only. Saddle horses kept in condition stand clothed in a kersey sheet, and girted with a broad roller, with occasionally the addition of a quarter-piece; the breast-plate is sometimes put on when going out to exercise; the hood is used to race horses only, except in case of sickness. All horses, except racers, are best without clothing in the summer season; at the most a linen sheet only should be allowed to avoid the dust and flies.

6708. *The grooming or dressing of horses* is generally thus practised:—Having tied up the horse's head, take a currycomb, and curry him all over his body, to raise the dandruff or scurf, beginning first at his neck, holding the left cheek of the head-stall in your left hand, and curry him from the setting on of his head, all along his neck, to his shoulder, and so go all over his body to the buttocks, down to his hocks; then change your hands, and curry him before on his breast, and laying your right arm over his back, join your right side to his left, and curry him all under his belly to his chest, and so all over very well, from the knees and shoulders upwards: after that, go to the far side, and do in like manner. Then take a dead horse's tail, or a dusting-cloth of cotton, and strike that dust away which the curry-comb has

raised. Then take a round brush, made of bristles, and dress him all over, both head, body, and legs, to the very fetlocks, always cleansing the brush from that dust which it gathers, by rubbing it upon the curry-comb. After that, take a hair-cloth, and rub him again all over very hard, both to take away the loose hairs, and to help to lay his coat; then wash your hands in fair water, and rub him all over with wet hands, as well head as body; for that will cleanse away all those hairs and dust the hair-cloth left. Lastly, take a clean cloth, and rub him all over till he be very dry; for that will make his coat smooth and clean. Then take another hair-cloth (for you should have two, one for his body and another for his legs), and rub all his legs exceedingly well, from the knees and hocks downwards to his very hoof, picking and dressing them very carefully about the fetlocks from gravel and dust, which will lie in the bending of his joints.

6709. *The curry-comb should not be too sharp*, or, at least, not used in a rude and severe manner, so as to be an object of torture and dread, instead of delight and gratification to the horse. It is too often the fate of thin-skinned horses to suffer much from the brutality of heavy-handed and ignorant fellows, who do not recollect that the unhappy animal is suffering, every time he writhes and attempts to escape from the comb or brush, the same tortures that they themselves experience when tickled on the soles of their feet.

6710. *The care of the legs and feet* forms a most important branch of stable discipline. The legs must be kept perfectly dry and clean. Dirt suffered to form a lodgment, or wet remaining upon the legs in cold weather, will fret the skin, and cause cracked heels, grease, mallenders and sellenders, rat's-tail, crown-scab, and such a train of stable plagues, as may baffle the most vigorous efforts during a whole winter. If any disposition to swellings, cracks, &c. make their appearance on the legs, particularly in winter, moderate bandaging, which every good groom knows how to perform, will contribute to remove the evil; if it, however, increase, have recourse to the veterinary directions. It forms a part of the constant attention of a good horse-keeper to see that the feet of his horses be well cleansed beneath the shoe with the picker from all small stones or gravel, at every return from abroad. The shoes must be examined, that their ends do not press into the crust, and that the nails be fast, and that the clinches do not rise to cut the horse. In these cases, instant application must be made to the farrier: horses ought by no means to remain in old shoes until the toe is worn away, or the webs become so thin that there is danger of their breaking, unless in case of brittle hoofs, when it is an object to shoe as seldom as possible. Upon the average, good shoes will wear near a month. Steeling the toes is, in general, a useful practice, but less necessary when the best iron is made use of. Where any tendency to dry hoofs exists, the feet should be stopped with equal parts of clay, cow-dung, and chamberlye every night; otherwise, twice or three times a week will be sufficient. A still better stopping is made by adding a little tar to the other matters. It is also prudent, when the hoofs have any tendency to hardness and contraction, to water the front part of the stall a little; and also occasionally, or constantly, to hang around the hoofs an apparatus, made by doubling a circle of woollen cloth over a tape, which should be tied around the fetlocks loosely: the two segments of the cloth will then fold around the hoof, and correspond to it in shape. This may be dipped in water, and will be found very convenient in keeping the feet moist and cool. Very brittle hoofs are greatly benefited by brushing them over with a mixture of whale oil and tar. It is considered as beneficial, in general, to take off the shoes of a horse who is necessitated to stand long in the stable, and who does no work, and to substitute tips; the growth of the crust and the enlargement of the heels being thereby promoted.

6711. *The care of the furniture and trappings* is another part of the duty of a horse-keeper. These are best kept in order by being instantly rubbed clean after use, and placed in a dry situation; by which method, neither oil nor scouring-paper is often found necessary. Great care should be taken to dry the pads of the saddles after journeys, and never to put a hardened and damp saddle upon the horse's back. The same is also necessary with regard to the body-clothes. The pads of the saddles ought to be kept perfectly soft, and free from dirt and sweat; and, after use, should be dried either in the sun or by the fire, and hung in a dry place: the body-clothes also should be washed much oftener than they generally are, and ever kept perfectly dry, and in a sweet state.

6712. *The exercising of horses* is essentially necessary for their health, as it counteracts the effects of the artificial life we force on them. High feeding, heated stables, and unnatural clothing are, particularly the first, counteracted by proper exercise; and without it, horses become pensive, fat, heavy, and greased; for, when the secretions do not find themselves natural vents by perspiration, &c., they will find themselves artificial ones. Exercise keeps down the fat, and it also hardens and condenses the muscles by drawing their fibres nearer together; it likewise enlarges the muscles. Thus the appearance, as well as the feel, when we handle the flesh of a horse in condition by proper exercise, is totally different from those of one merely full of flesh by fat, &c. Exercise increases the wind by taking up the useless fat, and by accustoming the lungs to expand themselves.

6713. *The quantity of exercise necessary for a horse* must be regulated by a variety of circumstances; as age, constitution, condition, and his ordinary work. A young horse requires more exercise than an old one, but it should be neither very long, nor very fatiguing. Some colts are observed to come out of the breaker's hands with splints and spavins, owing to the severe exercise they have undergone. When horses are in general work, a little walking exercise in the morning in body-clothes, if the condition be very high, or the weather be very cold, is all that is necessary: but, on days when their common work is not expected to occur, a full-fed horse should be exercised twice a day, an hour at each time; or, if only once a day, then an hour and a half or two hours' exercise should be given; two thirds of which ought to be passed in walking; the other should be passed in a moderate trot in the hackney, and divided into galloping and trotting in the hunter. The racer has his regular gallops at stated periods; but the exercise of each should always finish with a walk of sufficient length, to bring the horse in cool, both in person and temper.

SECT. XVI. *Management and Working of Horses.*

6714. *The working of horses* includes the racing, hunting, and journeying of saddle horses; and the treatment in harness of coach, waggon, cart and farm horses.

SUBSECT. 1. *Management and Working of Race Horses.*

6715. *In the managing and working of race horses*, three things are to be considered, the preparation of the horse, the conduct of the rider, and the after-treatment of the horse. The preparation of a race horse for running a race is not the work of a few days, if there be any great dependence on the success. A month at least is required to harden his muscles in training, by proper food and exercise, and to refine his wind, by clearing his body to that degree of perfection that is attainable by art. It is first necessary to ascertain correctly the present state of the horse, as whether he be low or high in flesh; and in either case a proper estimate should be formed of the time and means required to bring him into true running condition.

6716. *If a race horse be low in flesh*, it is necessary to judge of the cause of such state, and to act accordingly, the necessary proceedings for which were detailed in treating of condition. (6425.) It is to be remarked, that spices are less to be depended on for this purpose than generous food, as malt mashes; and if any thing of the kind be used, let it be the simple cordial ball. (*Vet. Pharm.* 6568.) Feed frequently, and by little at a time: while he is thus low, let his exercise be walking only, and by no means spare his water, or he will become hide-bound: carefully watch him, that full feeding may not disagree

by making his heels swell, or his coat unthrifty; and if such appearances occur, mash him, and begin his scourings, otherwise abstain from physicking until he is in better health. As he improves in condition, increase his exercise, but not to such a degree as to make him sweat. His food must now be the best oats and beans, with wheaten or barley bread; the beans and oats are to be put into a bag, and beaten till the hulls are all off, and then winnowed clean; and the bread, instead of being chipped in the common way, is to have the crust clean off.

6717. *If the horse be in good flesh and spirits* when taken up for his month's preparation, cordials are altogether unnecessary; and the chief business will be to give him good food, and so much exercise as will keep him in wind, without over-sweating or fatiguing him. When he takes larger exercise afterwards, towards the end of the month, it will be proper to have some horses in the place to run against him. This will put him upon his mettle, and the beating them will give him spirits. This, however, is to be cautiously observed, that he has not an injurious, or in the language of jockeys, a bloody heat given him for ten days or a fortnight before the plate is to be run for; and that the last heat that is given him the day before the race must be in his clothes: this will make him run with greatly more vigour when stripped for the race, and feeling the cold wind on every part. In the second week, the horse should have the same food and more exercise: and in the last fortnight he must have dried oats, that have been hulled by beating; after this jockeys wet them with the whites of eggs, beaten up, and then laid out in the sun to dry; and when as dry as before, the horse is to have them: this sort of food being considered by them as very light of digestion, and very good for the creature's wind. The beans in this time should be given more sparingly and the bread should be made of three parts wheat and one part beans, or of wheat and barley in equal parts. If he should become costive under this course, he must then have bran-water to drink, or some ale and whites of eggs beaten together; and keep his body moist. In the last week all mashing is to be omitted, and barley-water given him in its place; and every day, till the day before the race, he should have his fill of hay; then he must have it given him more sparingly, that he may have time to digest it; and in the morning of the race-day, he must have a toast or two of white bread soaked in ale, and the same just before he is led out of the field. This is an excellent method, because the two extremes of fulness and fasting are at this time to be equally avoided; the one affecting his wind, and the other occasioning a faintness that may make him lose. After he has had his food, the litter is to be shook up, and the stable kept quiet, that he may be disturbed by nothing till he is taken out to run.

6718. *In the choice of a rider* for winning a race, it is necessary, as far as possible, to select one that is not only expert and able, but honest. He must have a very close seat, his knees being turned close to the saddle skirts, and held firmly there; and the toes turned inwards, so that the spurs may be turned outward to the horse's belly; his left hand governing the horse's mouth, and his right the whip. During the whole time of the race, he must take care to sit firm in the saddle, without waving or standing up in the stirrups. Some jockeys fancy the last a becoming seat; but it is certain, that all motions of this kind do really incommode the horse. In spurring the horse, it is not to be done by sticking the calves of the legs close to the horse's sides, as if it were intended to press the wind out of his body; but, on the contrary, the toes are to be turned a little outwards, that the heels being brought in, the spurs may just be brought to touch the sides. A sharp touch of this kind will be of more service toward the quickening of a horse's pace, and will sooner draw blood than one of the common coarse kicks. The expert jockey will never spur his horse until there is great occasion, and then he will avoid striking him under the fore bowels between the shoulders and the girt; this is the tenderest part of a horse, and a touch there is to be reserved for the greatest extremity.

6719. *As to whipping the horse*, it ought always to be done over the shoulder, on the near side, except in very hard running, and on the point of victory; then the horse is to be struck on the flank with a strong jerk; for the skin is the most tender of all there, and most sensible of the lash. When a horse is whipped and spurred, and is at the top of his speed, if he clap his ears in his pole, or whisk his tail, it is a proof that the jockey treats him hard, and then he ought to give him as much comfort as he can by sawing the snaffle backwards and forwards in his mouth, and by that means forcing him to open his mouth, which will give him wind, and be of great service. If there be any high wind stirring in the time of riding, the artful jockey will let his adversary lead, holding hard behind him, till he sees an opportunity of giving a loose; yet, in this case, he must keep so close behind, that the other horse may keep the wind from him; and that he, sitting low, may at once shelter himself under him, and assist the strength of the horse. If the wind happen to be in their back, the expert jockey is to keep directly behind the adversary, that he may have all the advantage of the wind to blow his horse along, as it were, and at the same time intercept it in regard to his adversary.

6720. *When running on level smooth ground*, the jockey is to beat his horse as much as the adversary will give him leave, because the horse is naturally more inclined to spend himself on this ground; on the contrary, on deep earths, he may have more liberty, as he will there spare himself.

6721. *In riding up hill* the horse is always to be favoured, by bearing him hard, for fear of running him out of wind; but in running down hill, if the horse's feet and shoulders will bear it, and the rider dares venture his neck, he may have a full loose. If the horse have the heels of the rest, the jockey must always spare him a little, that he may have a reserve of strength to make a push at the last post.

6722. *On the jockey's knowing the nature of the horse that is to run against him*, a great deal depends; for by managing accordingly, great advantages are to be obtained: thus, if the opposite horse is of a hot and fiery disposition, the jockey is either to run just behind him, or cheek by jowl with him, making a noise with the whip, and by that means forcing him on faster than his rider would have him, and consequently, spending him so much the sooner; or else keep him just before him, in such a slow gallop, that he may either overreach, or by treading on the heels of the fore-horse, endanger tumbling over. Whatever be the ground that the adversary's horse runs worst on, the cunning jockey is to ride the most violently over; and by this means it will often happen, that in following he either stumbles or claps on the back sinews. The several corrections of the hand, the whip, and the spur, are also to be observed in the adversary, and in what manner he makes use of them: and when it is perceived by any of the symptoms of holding down the ears, or whisking the tail, or stretching out the nose like a pig, that the horse is almost blown, the business is to keep him on to this speed, and he will be soon thrown out or distanced. If the horse of the opponent looks dull, it is a sign his strength fails him; and if his flanks beat much, it is a sign that his wind begins to fail him, and his strength will soon do so too.

6723. *The after-management of a horse who has run* includes the treatment between the heats, and the treatment after the race is over. After every heat for a plate, there must be dry straw, and dry clothes, both linen and woollen, ready to rub him down all over, after taking off the sweat with what is called a sweat-knife; that is, a piece of an old sword-blade, or some such thing. After the horse has been well rubbed, he should be chafed all over with cloths wetted in common water, till the time of starting again. When it is certainly known that the horse is good at the bottom, and will stick at the mark, he should be rid every heat to the best of his performance; and the jockey is as much as possible to avoid riding at any particular horse, or staying for any, but to ride out the whole heat with the best speed he can. If, on the contrary, he has a fiery horse to ride, and one that is hard to manage, hard-mouthed, and difficult to be held, he is to be started behind the rest of the horses with all imaginable coolness and gentleness; and when he begins to ride at some command, then the jockey is to put up to the other horses; and if they ride at their ease, and are hard held, they are to be drawn on faster; and if it be perceived that their wind begins to rake hot, and they want a sob, the business is to keep them up to that speed; and when they are all come within three quarters of a mile of the post, then is the time to push for it, and use the utmost speed in the creature's power.

6724. *When the race is over*, the horse is immediately to be clothed up and rode home; and immediately

on his coming into the stable, the following drink is to be given him: — Beat up the yolks of three eggs, and put them into a pint and a half of sound ale, made warm; and let it be given with a horn. After this, he is to be rubbed well down, and the saddle-place rubbed over with warm water and vinegar, and the places where the spurs have touched, with the same; after this he should have a feed of rye-bread, then a good mash, and at some time after these as much hay and oats as he will eat. His legs, after this, should be bathed some time with a mixture of vinegar and water.

SUBJECT. 2. *Management and Working of the Hunter.*

6725. *The managing and working of the hunter* includes his preparation for hunting, his condition, and his treatment while taking his regular day's work in the field, whether after buck, fox, or hare hounds.

6726. *The preparation of the hunter* must, like that of the race horse, be commenced by an estimate of his state and condition. If taken fresh from grass, it should be in due time: first, that he may be well prepared; and next, because the grass does not yield much nutriment in the heat of summer. A still better method is to continue to let him run out in the day and graze, having a shed to house himself from heat and rain. He is also to be fed and exercised, nearly as in the common training, for hunting condition. In this way he is sure to be free from cracks, hide-bound, or surfeit; and he will prove infinitely more hardy afterwards. It is even the practice with some of the best sportsmen to allow their horses to run out all the hunting season, unless the weather be very severe; when they are only stabled in a loose place. They are allowed as much corn as they can eat, and are found, if a little rougher in their coats, infinitely superior in hardihood, and exemption from the dangers of cold.

6727. *A hunter taken from grass* or in very low case should be treated as already fully detailed under condition. (6424.) Great care must be taken that all the alterations in heat of stable, clothing, feeding, &c., are gradually brought about; by which means his flesh will harden gradually, and by using first walking exercise, and increasing it as he advances in flesh and strength, his wind also will become excellent.

6728. *In the physicking of hunters*, particularly when they are low in flesh, much caution is requisite that it be not over-done. It is the practice with some, and by no means a bad one, to give no physic; but to give more time in the preparation. Others, again, give mild grass physic, which is an excellent plan, when the weather is fine. (See *Physicking*, 6544.)

6729. *The preparation of a hunter in full flesh and not from grass* depends principally on regular exercise, and the best hard food; physicking him or not, according as he may be suspected to be foul, or as his wind may seem to want mending; but above all, whatever is done, should be done regularly; and his exercise should be rather long continued than violent. Oats with beans are the proper hard food for hunters, taking care that the beans do not constipate the bowels; which must be obviated by bran mixed with the other food, if such should be the case. Bread is not necessary, but for tender delicate horses; but every thing should be of the best.

6730. *The day before a horse is to hunt* it is common to treat him somewhat differently, but this is seldom necessary. It is evident he should be well fed, and that not late at night, that he may lie down early. Some feed in the morning, which others avoid; but when it is considered, as has been fully explained (6404.), how ill a horse bears fasting, it will be at once seen, that if very early in the morning, as by five o'clock, he could be fed with a moderate quantity of corn wetted, it would tend to support him through the day.

6731. *On the return of a horse from hunting*, the care bestowed on him should be extreme; as on it depends the immediate recovery of his strength. If he have fasted very long, and particularly if he be disinclined to eat of himself, horn down a pint of ale, with two pints of thick gruel. No prudent sportsman will bring in a horse hot; but if unavoidable accidents prevent this caution, let the horse be again led out for a few minutes, hooded and clothed; but he must have fresh clothes when afterwards dressed. Encourage him to stale as quickly as possible, after which proceed to hand-rub him all over carefully, placing before him a little of the best hay well sprinkled with water. If he refuse this, offer him three quarts of very clean chilled water. When perfectly cleaned, let his feet be carefully examined, that stubs have not pierced them, or that his shoes have not been forced awry by over-reaching, or by the suction of clayey ground; or that thorns be not lodged in his knees, hocks, and sinews. After all these matters have been well attended to, remove him from his stall to a loose box, well bedded up. A loose box is invaluable to a hunter; it gives room for stirring to prevent the swelling of the legs; and is better than bandaging when it can be avoided, which gives a disinclination to lie down. If the horse be off his food the next day, give him a cordial ball (*Vet. Pharm.* 6568.) and a malt mash, and afterwards a few cut carrots, which will assist to bring him round more speedily.

SUBJECT. 3. *Working and Management of Riding Horses.*

6732. *The working and managing of hackney or riding horses* include what is required for them as pleasure horses for ordinary airings; and what they require when used for purposes of travelling or long journeyings. It embraces also their stable management in general, with the proper care of horse and stable appointments: all which are usually entrusted to a servant, popularly called a groom, whose qualifications should be, moderate size, light weight, activity and courage, joined with extreme mildness and good temper; and above all, a natural love of horses, by which every thing required is done as a pleasure for the animal he loves, and not as a task for those he is indifferent to.

6733. *The hackney for gentlemen's airings* should be in high condition, because a fine coat is usually thought requisite; and here the groom ought to be diligent that he may keep up this condition by regularity and dressing, more than by heat, clothing, and cordials. Whenever his master does not use his horse, he must not fail to exercise him (but principally by walking) to keep up his condition, and to keep down useless flesh and swellings of the heels. The horse appointments are to be peculiarly bright and clean. The bridle should be billeted and buckled, that the bits may be removed to clean them without soiling the leather, which cleaning ought not to be done with rough materials, but fine powder and polishing. On the return from exercise, they should be wiped dry and then oiled. Two pair of girths should be used, that a clean pair may always be ready, and the same if saddle cloths are used.

6734. *The preparation for, and the care of a horse on, a journey* involve many particulars which should not escape the eye of the master. The first is, Is the horse in hard travelling condition? Next, Do his appointments all fit, and are they in proper order? The bridle for journeying should always be a double curbed one. The snaffle can be ridden with, certainly; but the snaffle cannot do the work of the curb, in staying a horse, in saving him from the ground under stumbling or fatigue, or throwing him on his haunches, or in lightening his mouth. The bridle should not be new, but one to which the horse is accustomed. It is of still more consequence that the saddle be one that the horse has worn before, and that fits him thoroughly. The girths should also be of the best materials to prevent accidents; and if the saddle be liable to come forward, however objectionable the appearance, a crupper had better be used. Some days before a long journey is attempted, if the shoes are not in order, shoe the horse; but by no means let it be done as you set off, otherwise having proceeded on the journey a few miles, you find that one foot is pricked, and lameness ensues; or, if this be not the case, one or more shoes pinch, or do not settle to the feet; all which cannot be so well altered as by your own smith.

6735. *It is always best to begin a long journey by short stages*, which accustoms the horse to continued exertion. This is the more particularly necessary if he have not been accustomed to travel thus, or if he be not in the best condition. The distance a horse can perform with ease depends greatly on circumstances.

Light carcassed horses, very young ones, and such as are low in flesh, require often baiting, particularly in hot weather; horses in full condition, above their work, and well carcassed, and such as are from seven to ten or twelve years old, are better when ridden a stage of fifteen or twenty miles, with a proportionate length of baiting time afterwards, than when baited often, with short stoppages: the state of the weather should also be considered; when it is very hot the stages should be necessarily shorter.

6736. *To a proper consideration of the baiting times on a journey*, the physiology of digestion should be studied. (6400.) Fatigue weakens the stomach; when we ourselves are tired, we seldom have much inclination to eat, and fatigue also prevents activity in the digestive powers. To allay these consequences, ride the horse gently the last two or three miles. If a handful of grass can be got at the road-side, it will wonderfully refresh your horse, and not delay you three minutes. In hot weather, let the horse have two or three go-downs (gulps), but not more, of water occasionally as you pass a pond; this tends to prevent excessive fatigue. Occasionally walk yourself up-hill, which greatly relieves him, and at such time remove the saddle, by shifting which, only half an inch, you greatly relieve him; and during this time, perhaps, he may stale, which also is very refreshing to him. It may be as well, in a flinty country, to take this opportunity of examining that no stones are got into the feet likewise.

6737. *When a horse is brought into an inn from his journey*, if he be very hot, first let him be allowed time to stale; let his saddle be taken off, and with a sweat knife draw the perspiration away; then, with a rug thrown over him, let him be led out and walked in some sheltered place till cool, by which means he will not afterwards break out into a secondary and hurtful sweat: but by no means let an idle ostler hang him to dry without the stable. Being now dried, remove him to the stable, where let some good hay, sprinkled with water, be placed before him: if very thirsty, give three or four quarts of water now, and the remainder in half an hour, and then let him be thoroughly dressed, hand-rubbed, foot-picked, and foot-washed; but by no means let him be ridden into water; or, if this practice is customary, and cannot be avoided, let it be not higher than the knees, and afterwards insist on the legs being rubbed perfectly dry; but good hand-rubbing and light sponging is better than washing. Having thus made him comfortable, proceed to feed him with corn and beans according as he is used.

6738. *To feed a horse when very hard ridden, or if weakly and tender*, it is often found useful to give bread, or bread with ale: if this be also refused, horn down oatmeal and ale, or gruel and ale. It is of the utmost consequence if the journey is to be of several days' continuance, or if it is to consist of a great distance in one or two days, that the baitings are sufficiently long to allow the horse to digest his food: digestion does not begin in less than an hour, and is not completed in less than three; consequently any bait that is less than two hours fails of its object; and such a horse rather travels on his former strength than on his renewed strength, and therefore it cannot continue. After a horse is fed he will sometimes lie down; by all means encourage this, and if he is used to do it, get him a retired corner stall for the purpose.

6739. *The night baiting of a journeying horse* should embrace all the foregoing particulars, with the addition of foot stopping; and care that his stable be of the usual temperature to that to which he is accustomed; and that no wind or rain can come to him. Give him now a full supply of water: if he has been at all exposed to cold, mash him, or if his dung be dried by heat, do the same; otherwise, let a good proportion of oats and beans be his supper, with hay, not to blow on half the night, but enough only to afford nutriment.

6740. *When returned home from a journey*, if it has been a severe one, let the horse have his fore shoes taken off, and, if possible, remove him to a loose box, with plenty of litter; but if the stones be rough, or the pavement be uneven, put on tips, or merely loosen the nails of those shoes he has on; keep the feet continually moist by a wet cloth, and stop them at night if the shoes be left on; mash him regularly, and if very much fatigued, or reduced, let him have malt or carrots, and if possible, turn him out an hour or two in the middle of the day to graze: bleeding or physicking are unnecessary, unless the horse shows signs of fear. If the legs be inclined to swell, bathe them with vinegar and chamberlye, and bandage them up during the day, but not at night, and the horse will soon recover to his former state.

SUBJECT. 4. *Horses in Carriages and Coaches.*

6741. *In working and managing horses in carriages*, two-wheeled chaises, and similar cases, great feeling and nicety is required, not to overload or overdrive the animal; to see that the weight is duly proportioned between the wheels and horse's back, and that the harness does not pinch; but no directions on



this head can be of much use, unless the driver be a humane and considerate person, and one who sets a just value on the services of the noble animal committed to him. In Russia, the drivers of two-wheeled carriages, as droscheys, sledges, and others, corresponding to our gigs and carriages, have a barbarous custom of teaching the horses to turn round their heads, the one to the left, and the other to the right (fig. 850.), the sight of which is very offensive to a stranger.

6742. *In working and managing coach horses*, the same attention to grooming in all its departments is required as for saddle horses. Coach horses should never be brought into full work before they are five years old: when well fed on hard food, they may be worked at an average of thirty miles a day at twice. In general they should not be longer than five or six hours in the yoke at a time. Their principal meals should be in the morning and after their work is over for the day, as the action of trotting fast materially impedes digestion.

SUBJECT. 5. *Working of Cart, Waggon, and Farm Horses.*

6743. *In working and managing cart and waggon horses*, a similar attention is requisite as for coach horses, though perhaps in a somewhat less degree, the animal being hardier.

6744. *The working and managing of farm horses* includes the age at which they are put to work, the quantity of work they should perform, and their feeding and general management.

6745. *The age at which horses are put to full work, in the labours of a farm*, is usually when four or five years old, according to the nature of the soil, and the numbers of the team; but they are always understood to be able to pay for their maintenance after they are three years old, by occasional work in ploughing and harrowing. Brown thinks it probable they might be put to work at four years old, were the same attention paid to their breeding and rearing that is paid to cattle and sheep.

6746. *The work which a farm horse ought to perform* is evidently a question of circumstances, which does not admit of any precise solution: a two-horse plough may, on an average, work about an English acre a day throughout the year; and, in general, according to the nature of the soil, and the labour that has been previously bestowed on it, a pair of horses, in ploughing, may travel daily from ten to fifteen

miles, overcoming a degree of resistance equal to from four to ten hundred weight. On a well made road, the same horses will draw about a ton in a two-wheeled cart for twenty or twenty-five miles every day; and one of the better sort, in the slow movement of the carrier or waggoner, commonly draws this weight by himself on the best turnpike roads. In some places horses are in the yoke, when the length of the day permits, nine hours, and in others ten hours a day; but for three or four months in winter, only from five to eight hours. In the former season they are allowed to feed and rest two hours from mid-day, and in the latter they have a little corn on the field, when working as long as there is day light, but none if they work only five or six hours. (*Sup. Enc. Brit. art. Agr.*)

6747. *The feeding of farm horses* is a subject of great agricultural importance, and has excited considerable discussion among speculative agriculturists, who have generally urged the great expenses attending it as an argument against horses, in favour of oxen. Others, without preferring oxen to horses, have, instead of corn and hay, proposed to feed them on roots, leaves, whins, and even haws from the hedges. The latter have been given in large quantities by West of Hampshire, and, it is said (*Complete Farmer, art. Team*), were found to answer. That horses as well as men may live on very inferior food is evident; but that either will be able to perform their work under such treatment, as well as if they were properly nourished, is contrary to reason and experience. It is observed by the judicious writer so often quoted, that horses can never perform their labour, according to the present courses of husbandry, on carrots, turnips, potatoes, or other roots alone, or as their chief food. They will work and thrive on such food; but they will work as much more, and thrive as much better, with oats or beans in addition, as fully to repay the difference in expense. One of the three meals a day, which farm horses usually receive, may consist of roots; and a few of them, every twenty-four hours, are highly conducive to the health of the animals: but we have never had occasion to see any horse work regularly throughout the year, in the way they are usually worked in the best cultivated districts, without an allowance of at least an English peck of oats, or mixed oats and beans, daily, less or more at particular periods, but rather more than this quantity for at least nine months in the year.

6748. *Brown* does not approve of giving much grain to young horses, thinking it expensive, and not so conducive to their health as when they are supported on green food. In the winter and spring months, a few turnips are eminently beneficial to young horses, by keeping their blood in good order, swelling their bone, and hastening their growth. A plentiful supply of grass in summer ought always to be allowed, as their condition through the winter depends greatly upon that circumstance. It is an object deserving of attention, that flesh once gained ought never to be lost, but that every animal whatever should be kept in a progressive state of improvement, and not suffered to take a retrograde course, which afterwards must be made up by extra feeding, or a loss be sustained, in a direct proportion to the degree of retrogradation that has actually occurred.

6749. *The teanness of a farmer's working cattle*, and their reluctant movements, clearly mark his unprosperous condition. There are particular operations, indeed, such as turnip-sowing, seeding, fallows, harvest-work, &c., which require to be executed with so great despatch in our variable climate, that unusual exertions are often indispensable. At these times, it is hardly possible, by the richest food and the most careful treatment, to prevent the animals from losing flesh, sometimes even when their spirit and vigour are not perceptibly impaired. Such labours, however, do not continue long, and should always be followed by a corresponding period of indulgence. It is particularly dangerous and unprofitable to begin the spring labour with horses worn down by bad treatment during winter. (*Sup. Enc. Brit. art. Agr.*)

6750. *Donaldson* observes, that the coarse garbage with which farm horses are commonly stuffed, profitably or otherwise, is the real cause of the frequent occurrence among them of blindness, grease, and colic; more particularly the last, which, with care, might be prevented from happening so frequently. The remedy lies in physic, once or twice a year; either the regular aloetic dose, or salts given in pails of warm water, or sulphur and cream of tartar; one third of the latter mixed in the corn. All horses kept in the stable become, more or less, internally loaded; and it is an error to suppose cart-horses are not equally benefited with others by purging physic.

6751. *The cleaning and dressing of farm horses* was formerly very little attended to; but at present its importance to the health of the animal is better understood. *Donaldson* recommends that the heels, legs, bend of the knee, and hock, the twist under the flanks; in short, all parts out of sight, of cart horses, whilst standing in the house, should be kept perfectly free from dirt and scurf, and the skin supple; the parts more in sight will take care of themselves. In a deep country, it is much the better practice, notwithstanding the prejudice to the contrary, to trim their legs coach-horse fashion. It is now well understood, the editor of *The Farmer's Magazine* observes, that the liberal use of the brush and the currycomb twice a day; frequent but moderate meals, consisting of a due proportion of succulent joined to more solid food; abundance of fresh litter, and great attention to method and cleanliness, are as indispensable in the stable of a farmer (as far as is consistent with a just regard to economy) as they have always been held to be in the treatment of horses kept for pleasure. Good dressing, with all well informed and attentive men, is considered to be no less necessary to the thriving of the horses than good feeding; according to a common expression, it is equal to half their food.

6752. *The general management of farm horses in the improved districts of the north* may be presented as a good example. There, for about four months in summer, horses are fed on pastures; or on clover and rye-grass, and tares cut green, and brought home to the stable or fold-yard; the latter method being by far the most economical and advantageous. For the other eight months, they are kept on the straw of oats, beans, and peas, and on clover and rye-grass hay. As soon as the grass fails towards the end of autumn, they have hay for a few weeks, and when the days become so short as to allow of no more than from six to eight hours' work, they are very generally fed with different kinds of straw, according to the circumstances of the farm; in the month of March they are again put to hay till the grass is ready for being cut. Throughout all the year they are allowed more or less corn, when constantly worked; and during the time they are on dry fodder, particularly when on straw, they have potatoes, yams, or Swedish turnips, once a day, sometimes boiled barley, and, in a few instances, carrots. A portion of some of these roots is of great importance to the health of horses, when succulent herbage is first exchanged for hay at the end of autumn; and it is no less so towards the latter end of spring, when hay has become sapless, and the labour is usually severe. At these two periods, therefore, it is the practice of all careful managers to give an ample allowance of some of these roots, even though they should be withheld for a few weeks during the intermediate period.

6753. *The quantity of these different articles of food* must depend on the size of the horses, and the labour they perform; and the value upon the prices of different seasons, and, in every season, on the situation of the farm with respect to markets, particularly for hay and roots, which bring a very different price near large towns, and at a few miles distant. It is for these reasons that the yearly expense of a horse's maintenance has been estimated at almost every sum, from 15*l.* to 40*l.* But it is only necessary to attend to the expense of feeding horses that are capable of performing the labour required of them, under the most correct and spirited management. Such horses are fed with oats, sometimes with beans, three times a day, for about eight months; and twice a day for the other four, when at grass; and, at the rate of eight feeds per bushel, each horse will eat fifteen quarters of oats, or twenty bolls Linlithgow measure in the year. When on hay, he will require about one stone of twenty-two pounds *avoirdupoise* daily, and five pounds more if he does not get roots. One English acre of clover and rye-grass, and tares, may be necessary for four months' soiling; and a quarter of an acre of potatoes, yams, or Swedish turnips, during the eight months he is fed with hay or straw. The use of these roots may admit of a small diminution of the quantity of corn in the winter months, or a part of it may be, as it almost always is, of an inferior quality.

6754. *The expense of feeding a horse throughout the year* may therefore be estimated, in regard to quantity, as follows:—

Oats, fifteen quarters.

Soiling, one acre of clover and rye-grass, and tares.

Hay part of October and November, March, April, and May, 1½ ton.

Straw for other four months, half the price of hay.

Potatoes, yams, or Swedish turnips, ¼ acre.

(*Sup.*, &c. art. *Agr.*)

6755. *The extent of land required for a horse's maintenance, supposing the soil to be of a medium quality*, may be about five acres; that is, for oats three acres, soiling one, and one more for hay and roots. On rich soils four acres will be sufficient; but on poor soils, and wherever horses are kept at pasture, the produce of six acres and a half, or seven acres, will be consumed by one of them, when worked in the manner already mentioned. The straw of about two acres must be allowed for fodder and litter, the last of which has not been stated above; because, at a distance from towns, what is allowed for litter must, at any rate, be converted into dung. If sixty acres, therefore, should be assumed as the average extent of land that may be kept in cultivation by two horses, according to the best courses of modern husbandry, the produce of ten acres of this will be required for their maintenance; or, a horse consumes the produce of one acre out of every six which he cultivates, according to a four or six years' course, and something more than one acre out of every five which he ploughs annually. (*General Report of Scotland*, vol. iii. p. 192.)

CHAP. II.

The Ass. — *E'quus Asinus* L. *Ane*, Fr.; *Esel*, Ger.; *Asno*, Span.; and *Asino*, Ital.

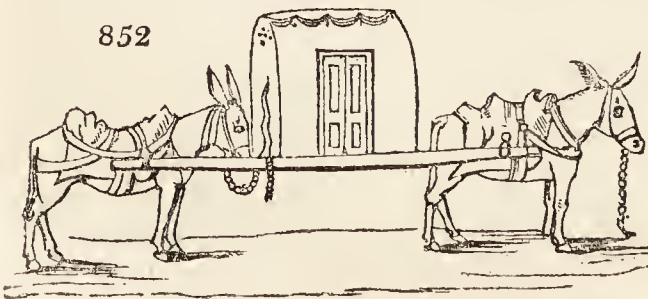
6756. *The ass* is a native of the mountainous deserts of Tartary, of Arabia, Persia, and other parts of the Asiatic continent; and at present is very generally domesticated throughout most civilised countries. The wild ass feeds chiefly on the most saline or bitter plants of the desert, as the kalis, atriplices, chenopodium, &c.; and also prefers the saltiest and most brackish water to that which is fresh. Of this the hunters are aware, and usually station themselves near the ponds to which they resort to drink. Their manners greatly resemble those of the wild horse. They assemble in troops under the conduct of a leader, or sentinel; and are extremely shy and vigilant. They will, however, stop in the midst of their course, and even suffer the approach of man, and then dart off with the utmost rapidity. They have been at all times celebrated for their swiftness. Their voice resembles that of the common ass, but is shriller.

6757. *The excellencies and defects of the common ass* have amply engaged the lively pens of several descriptive writers on the history of animals; and of none with more happy effect than those of the eloquent Buffon, and the ingenious Abbé la Pluche. The ass, in his natural temper, is humble, patient, and quiet, and bears correction with firmness. He is extremely hardy, both with regard to the quantity and quality of his food, contenting himself with the most harsh and disagreeable herbs, which other animals will scarcely touch. In the choice of water he is, however, very nice; drinking only of that which is perfectly clear, and at brooks with which he is acquainted. He is very serviceable to many persons who are not able to buy or keep horses; especially where they live near heaths or commons, the barrenest of which will keep him; being contented with any kind of coarse herbage, such as dry leaves, stalks, thistles, briers, chaff, and any sort of straw. He requires very little looking after, and sustains labour beyond most others. He is seldom or never sick; and endures hunger and thirst longer than most other kinds of animals. The ass may be made use of in husbandry to plough light lands, to carry burdens, to draw in mills, to fetch water, cut chaff, or any other similar purposes. The female (*fig.* 851.) is also useful in many cases for her milk, which is excellent; and she might be of more advantage to the farmer if used, as in foreign countries, for the breeding of mules. The skin of the ass is extremely hard, and very elastic, and is used for various purposes; such as to cover drums, make shoes, or parchment. It is of the skin of this animal that the Orientals make the fagri, or, as we call it, shagreen. The milk of the ass is the lightest of all milks, and is recommended by medical men

to persons of delicate stomachs; the flesh, and the hair of the tail and mane, are used as those of the horse.

6758. *The ass attains his full growth* in three or four years, and may then be put to work. Like the horse, he will live to 25 or 30 years: it is said the female lives longer than the male; but, perhaps, this happens from their being often pregnant, and at those times having some care taken of them, instead of which the males are constantly worn out with fatigue and blows. They sleep less than the horse, and do not lie down to sleep, except when they are exceedingly tired. The male ass also lasts much longer than the stallion; the older he is, the more ardent he appears; and, in general, the health of this animal is much better than that of the horse; he is less delicate, and not nearly so subject to maladies. Ophthalmia, which may be reckoned among the indigenæ of the cultivated horse, is almost unknown to the ass. Contraction of the feet also is very seldom observed in him.

6759. *The different breeds or races of the ass* are much less known than those of the horse; because in this country they have not been taken the same care of, or followed with the same attention. Travellers inform us that there are two sorts of asses in Persia; one of which, being slow and heavy, is used for burdens; and the other is kept like horses for the saddle. The latter have smooth hair, carry their heads well, and are much quicker in their motion; but when they ride them they sit nearer the buttocks than when on horseback. They are dressed like horses, and like them are taught to amble; and they cleave their nostrils to give them more room for breathing. According to Dr. Russell, there are two sorts in Syria, one of which is like ours, and the other very large, with remarkably long ears; but both kinds are employed for the purpose of carrying burdens and sedan chairs.



(*fig.* 852.)

6760. *In breeding from the ass*, the same general rules should be attended to as in the horse breeding. The male ass will procreate at the age of two and a half years, and the female still earlier. The stallion ass should be chosen from the largest and strongest of his species; he must at least be three years old, but should not exceed ten; his legs should be long, his body plump, head long and light, eyes brisk, nostrils and chest large, neck long, loins fleshy, ribs broad, rump flat, tail short, hair shining, soft to the touch, and of a deep grey. Those are reckoned the best shaped that are well squared, have large eyes, wide nostrils, long necks, broad breasts, high shoulders, a great back, short tail, the hair sleek, and of a blackish colour.

6761. *The best time for covering* is from the latter end of May to the beginning of June, nor must the female be hard worked whilst with foal, for fear of casting; but the more the male is worked, in moderation, the better he will thrive. She brings forth her foal in about a twelvemonth, but, to preserve a good breed, she should not produce more than one in two years. She should be covered between the months of March and June. The best age to breed at is from three years old to ten. When the foal is cast, it is proper to let it run a year with the dam, and then wean it by tying up and giving it grass, and sometimes milk; and, when it has forgot the teat, it should be turned out into a pasture; but if it be in winter, it must then be fed at times, till it be able to shift for itself.

6762. *The ass may be broken and trained* at the end of the second year; but should not be worked sooner than the third year. Breaking is easily effected when two years old, or it may be let alone still longer, as till three years. It is easily done by laying small weights on his back, and increasing them by degrees; then set a boy upon him, and so increase the weights as may be proper, till they are sufficiently heavy.

6763. *The age of the ass* is known by his teeth in the same manner as the horse. At two years and a half old, the first middle incisive teeth fall out, and the other on each side soon follow; they are renewed at the same time, and in the same order.

6764. *The anatomy and physiology of the ass* do not differ from those of the horse essentially. The concha cartilages of the ears are, however, considerably more elongated; the spinous processes of the dorsal vertebræ forming the withers are less extensive; and the bones of the extremities in general are less angularly placed, from whence results his inferiority in speed. It is also to the unbending lines of the spine, that his motions are rendered so uneasy to a person placed on the middle of his back. Some specialty occurs in the feet, which, like the horses of arid climes, are small and upright. His laryngeal sonorous sacs and *cordæ vocales* are not altogether like those of the horse, from whence his aptitude to bray instead of neighing. In the ass there are three laryngeal sacs as in the horse; but instead of a wide opening into them, there is a small round hole, and the interior sac is a real bag of considerable size. In the horse there is also, at the commissure of the *cordæ vocales*, a slight membranous fold not visible in the ass. These organs in the mule are compounded of these forms. Braying appears produced through the mouth, whereas neighing is principally effected by the nose. There is a hollow membranous cavity at the back of the mouth that is greatly assistant to this trumpet-like noise, which is effected by convulsively displacing the *vèlum palàti* by alternate inspirations and expirations.

6765. *The diseases of the ass*, as far as they are known, bear a general resemblance to those of the horse. As he is more exposed, however, and left to live in a state more approaching to natural, he has few diseases. Those few, however, are less attended to than they ought to be; and it is for the veterinary practitioner to extend to this useful and patient animal the benefit of his art, in common with those of other animals. The ass is seldom or never troubled with vermin, probably from the hardness of its skin.

6766. *The ass is shod* with a narrow web, and with heels projecting beyond the heel of the foot, and slightly turned up, for he seldom overreaches; but much care is required in using small nails, and in very carefully driving them. The hinder shoes differ little from those used for the fore feet.



CHAP. III.

The Mule and Hinny, Hybrids of the Horse and Ass.

6767. *The mule* (*Equus Asinus* var. γ *Mulus* L. *Grand Mulet* Fr.; *Grosser Maulessel*, Ger.; *Mula*, Span. and Ital.) is the hybrid produce of an ass with a mare; having a large clumsy head, long erect ears, a short mane, and a thin tail.

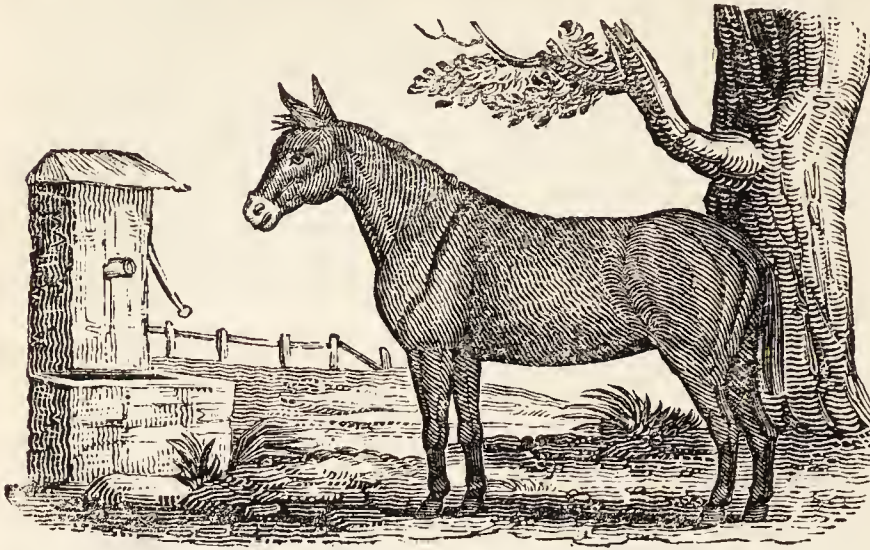
6768. *The hinny* (*Equus Asinus*, var. δ *Hinnus* L. *Bardeau* or *Petit Mulet*, Fr.; *Kleiner Maulessel*, Ger.; *Mulo*, Span. and Ital.) is the hybrid produce between the she-ass and a stallion; the head is long and thin, the ears are like those of a horse, the mane is short, and the tail is well filled with hair. The hinny is much less common than the mule; because, being less hardy and useful than the other, he is never cultivated.

6769. *The mule*, commonly so called, is much valued for the saddle, and for drawing carriages in Spain, Portugal, Italy, and the East, and in the warmer parts of America. In those countries where great attention is paid to the breed, it is as tall as the horse, exceedingly well limbed, but not so handsome, especially about the head and tail. These animals are mostly sterile; some, indeed, have thought that they are altogether incapable of producing their kind; but some few instances have occurred in which female mules have had foals, and in which even the male has impregnated females both of the ass and horse species, though such instances are exceedingly rare.

6770. *The mules made use of in the southern parts of Europe* are now brought to an astonishing perfection as well as great size. (fig. 853.) They are usually black, strong, well-limbed, and large, being mostly bred out of fine Spanish mares. They are sometimes fifteen or sixteen hands high, and the best of them worth forty or fifty pounds. No creatures are so proper for large burdens, and none so sure-footed. They are much stronger for draught than our horses, and are often as thickset as our dray-horses, and will travel several months together, with six or eight hundred weight upon their backs. Some think it surprising that these animals are not more propagated here, as they are so much hardier and stronger than horses, less subject to diseases, and capable of living and working to twice the age of a horse. Those that are bred in cold countries are more hardy and fit for labour than those bred in hot; and those which are light made are fitter for riding than horses, as to the walk and trot; but they are apt to gallop rough; though these do it much less than the short-made ones. The general complaint made against them is, that they kick and are stubborn; but this is owing to neglect in breeding them, for they are as gentle as horses in countries where they are bred with proper care.

6771. *In the breeding of mules*, mares that are of a very large breed and well made should be employed. They should be young, full of life, large barrelled, but small limbed, with a moderate-sized head, and a good forehead. It is found of advantage to have the foals from the time of their being dropped often

handled, to make them gentle : it prevents their hurting themselves by skittishness and sudden frights ; and they are much easier broken at the proper age, and become docile and harmless, having nothing of that viciousness which is so commonly complained of in these animals. They may be broken at three years old, but should never be permitted to do much hard work till four, as they are thus secured from being hurt by hard labour, till they have acquired strength enough to bear it without injury. An expert breeder of these animals found, that feeding them too well while young, was not only incurring a much larger expense than was any way necessary, but also made them wonderfully nice and delicate in their appetites ever after. He therefore contented himself with giving them food enough to prevent their losing flesh, and to keep up their growth without palling their



appetites with delicacies, or making them over-fat : he also took care to defend them from the injuries of the weather by allowing them stable-room, and good litter to sleep on, besides causing them every day to be well rubbed down with a hard wisp of straw by an active groom. This was scarcely ever omitted, particularly in cold, raw, wet weather, when they were least inclined to exercise themselves. When three years old, mules are proper for use.

6772. *The shoe for the mule* is by some made not unlike the bar shoe before, and the common shoe behind ; by some both fore and hind shoes are made to project considerably beyond the toe, under an idea of increasing the points of contact with the ground : but the most usual shoe is one formed between the usual horse and ass shoe.

CHAP. IV.

Neat or Horned Cattle. — *Bó*s L. ; *Mammàlia Pécora* L., and *Ruminàlea* Cuv. *Bêtes à corne*, Fr. ; *Vieh*, Ger. ; *Ganado*, Span. ; and *Bestiame*, Ital.

6773. *The neat or horned cattle used in agriculture* are included under two species of *Bó*s ; the *B. Taúrus* or ox, and the *B. búbulus* or buffalo ; the latter less used in Britain than on the Continent and in other countries. These animals are more universally used as beasts of draught and burden than the horse, and have the additional advantage of furnishing excellent food and other valuable products. There is scarcely a country in which the ox or the buffalo is not either indigenous, or naturalised and cultivated ; while in many parts of the world the horse is either wanting, or reserved for the purposes of war or the saddle.

SECT. I. *The Ox.* — *Bó*s *Taúrus* L. ; *Ochs*, Ger. ; *Bœuf*, Fr. ; *Buey*, Span. ; and *Bue*, Ital.

6774. *The male ox* is the bull (*Taureau*, Fr. ; *Stier*, Ger. ; *Toro*, Span. and Ital.) and the female the cow (*Vache*, Fr. ; *Kuh*, Ger. ; and *Vaca*, Span. and Ital.). The bull and cow inhabit various parts of the world, and, as already observed, are domesticated every where. In most countries, however, they are the mere creatures of soil and climate, the same attention in breeding and rearing that is bestowed on the horse being withheld ; the natural habits little restrained or the form little improved for the purposes of milking, fattening, or for labour. It is almost exclusively in Britain that this race of animals has been ameliorated so as to present breeds for each of these purposes, far superior to what are to be found in any other country. Notwithstanding this, however, much certainly remains to be known regarding the nutriment afforded by different kinds of herbage and roots ; the quantity of food consumed by different breeds, in proportion as well to their weight at the time, as to the ratio of their increase ; and the propriety of employing large or small animals in any given circumstances. Even with regard to the degrees of improvement made by fattening cattle generally, from the consumption of a given weight of roots or herbage, no great accuracy is commonly attempted ; machines for weighing the cattle themselves and their food, from time to time, not being yet in general use in any part of Britain. We shall consider this valuable family as to variety, criteria, breeding, earing, feeding, working, fattening, and milking : the manufacture of milk will be treated of in a succeeding chapter.

SUBSECT. 1. *Varieties and Breeds of the Bull.*

6775. *The varieties of the wild ox* are the bonasus and the bison (*fig. 112.*) ; the first with a long mane, and the last with a gibbous back. They inhabit the woods in Madagascar and many other countries of the East ; and the bison is even said to be found in Poland.

6776 *The varieties of the European cow*, according to Aiton, are innumerable. The pliancy of their nature is such, that they have been formed into many diversities of shape, and various qualities have been given them, very different from the original stock. The *uris*, or cows of Lithuania, are almost as large as the elephant; while some of those on the Grampian hills are little above the size of a goat; and cows are found of every diversity of size between the one and the other. They are not less varied in their shapes. The *bison*, which is a species of the cow family, and which readily propagates with our cows, wears a strong shaggy mane, like the lion; a beard, like the goat; as much hair under its neck and breast as covers its fore legs; a hump upon its shoulders, nearly as large as that worn by the camel (sometimes forty or fifty pounds in weight), with a tail that scarcely reaches the top of its buttock; and it resembles the lion much more than it does our domesticated cows, or other varieties of its own species. (*Aiton.*)

6777. *The diversity of qualities in the cow family* is also very great. Our cows are so grovelling and inactive, that they scarcely know the road from their stall to their pasture; while those of the Hottentots are so tractable as to be intrusted with the charge of other animals, and keep them from trespassing on the fields of grain, or other forbidden ground. They also fight their master's battles, and gore his enemies with their horns. Our dairy cows are so feeble and inactive, that they are hurt by travelling twice a day, even slowly, one mile from the byre to their pasture; while those of Tartary are used as riding animals, and in drawing carriages. Those of Hindostan draw the coaches, and maintain their rates with horses at the full trot; and the Hottentots teach their cows to hunt down the elk antelope. Cows of the wild neglected breed can with difficulty be removed from one enclosure or one hill to another; while those on whom due attention has been bestowed are docile, and submit to perform all sorts of labour. Some cows will yield upwards of twenty Scots pints of milk per day, while others will not give so much in ten, perhaps not in twenty days. These are not so many different species of animals, but all of them one and the same species, all capable of generating with each other a perfect offspring. All these varieties have been formed from the parent stock, partly by the diversity of soil and climate, or other accidental or adventitious circumstances; and partly of late by human skill and industry. (*Dairy Husbandry*, p. 17.)

6778. *The varieties of the cultivated ox* are the European, Indian, Zebu, Surat, Abyssinian, Madagascar, Tinian, and African. From the European variety have been formed the different breeds cultivated in Britain. They are very numerous, but we shall only notice such as are in most esteem. These different breeds are generally distinguished by the length or flexure of their horns; by the absence of horns; by the districts where they are supposed to have originated, or in which they abound, or exist in the greatest purity; or by the name of the breeder.

6779. *The long-horned or Lancashire breed of cattle* (*fig. 854.*) is distinguished from others by the length

854

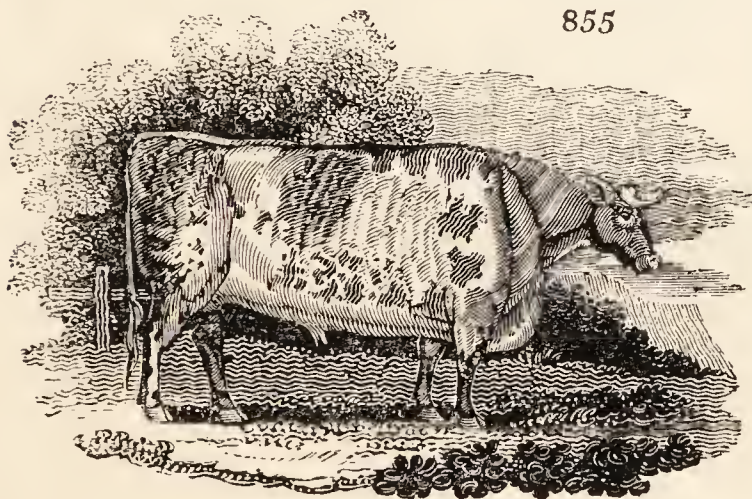


of their horns, the thickness and firm texture of their hides, the length and closeness of their hair, the large size of their hoofs, and their coarse, leathery, thick necks: they are likewise deeper in their fore quarters, and lighter in their hind quarters, than most other breeds; narrower in their shape, less in point of weight than the short horns, though better weighers in proportion to their size; and though they give considerably less milk, it is said to afford more cream in proportion to its quantity. They are more varied in their colour than any of the other breeds; but, whatever the colour be, they have in general a white streak along their back, which the breeders term *finched*, and mostly a white spot on the inside of the hough. (*Culley*, p. 53.) In a general view, this race, notwithstanding the singular

efforts that have been made towards its improvement, remains with little alteration; for, except in Leicestershire, none of the subvarieties (which differ a little in almost every one of those counties where

the long horns prevail) have undergone any radical change or any obvious improvement. The improved breed of Leicestershire (*fig. 855.*) is said to have been formed by Webster, of Cauley, near Coventry, in Warwickshire, by means of six cows brought from the banks of the Trent, about the beginning of the present century, which were crossed with bulls from Westmoreland and Lancashire. Bakewell of Dishley, in Leicestershire, afterwards got the lead as a breeder, by selecting from the Cauley stock; and the stocks of several other eminent breeders have been traced to the same source. (*Marshal's Midland Counties*, vol. i. p. 318.)

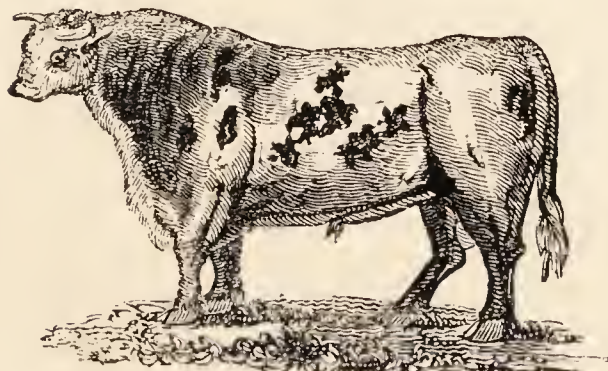
855



6780. *The short-horned*, sometimes called the Dutch breed (*fig. 856.*), is known by a variety of names, taken from the districts where they form the principal cattle stock, or where most atten-

tion has been paid to their improvement: thus, different families of this race are distinguished by the names of the *Holderness*, the *Teeswater*, the *Yorkshire*, *Durham*, *Northumberland*, and other breeds.

856



The *Teeswater* breed, a variety of short horns, established on the banks of the Tees, at the head of the vale of York, is at present in the highest estimation, and is alleged to be the true Yorkshire short-horned breed. Bulls and cows from this stock, purchased at most extraordinary prices, are spread over all the north of England, and the border counties of Scotland. The bone, head, and neck of these cattle are fine; the hide is very thin; the chine full; the loin broad; the carcass throughout large and well fashioned; and the flesh and fatting quality equal, or perhaps superior, to those of any other large breed. The short-horns give a greater quantity of milk than any other cattle; a cow usually yielding twenty-four quarts of milk per day, making three firkins of butter during the grass season: their colours are much varied, but they are generally

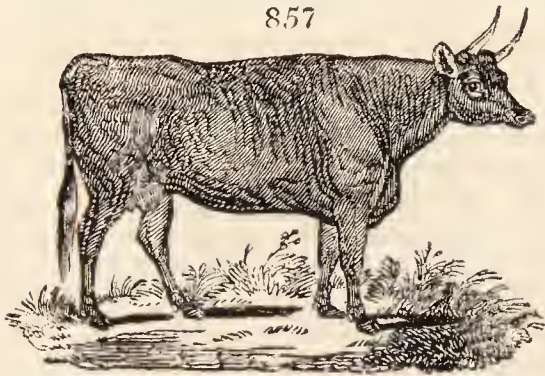
red and white mixed, or what the breeders call *flecked*. The heaviest and largest oxen of the short-horned breed, when properly fed, victual the East India ships, as they produce the thickest beef, which,

by retaining its juices, is the best adapted for such long voyages. Our royal navy should also be victualled from these; but, from the jobs made by contractors, and from other abuses, it is feared our honest tars are often fed with beef of an inferior quality; however, the coal ships from Newcastle, Shields, Sunderland, &c., are wholly supplied with the beef of these valuable animals. These oxen commonly weigh from 60 to 100 stone (14 lbs. to the stone); and they have several times been fed to 120, 130, and some particular ones to upwards of 150 stone, the fore-quarters only. (*Culley*, p. 48.)

6781. *In comparing the breeds of long and short horned cattle*, Culley observes that the long-horns excel in the thickness and firm texture of the hide, in the length and closeness of the hair, in their beef being finer-grained, and more mixed and marbled than that of the short-horns, in weighing more in proportion to their size, and in giving richer milk; but they are inferior to the short-horns, in giving a less quantity of milk, in weighing less upon the whole, in affording less tallow when killed, in being generally slower feeders, and in being coarser made and more leathery or bullish in the under side of the neck. In few words, says he, the long-horns excel in the hide, hair, and quality of the beef; the short-horns in the quantity of beef, tallow, and milk. Each breed has long had, and probably may have, its particular advocates; but if he may hazard a conjecture, is it not probable that both kinds may have their particular advantages in different situations? Why not the thick firm hides, and long close-set hair, of the one kind, be a protection and security against those impetuous winds and heavy rains to which the west coast of this island is so subject; while the more regular seasons and mild climate upon the east coast are more suitable to the constitutions of the short-horns.

6782. *The middle-horned breeds* comprehend, in like manner, several local varieties, of which the most noted are the *Devons*, the *Sussexes*, and the *Herefords*; the last two, according to Culley, being varieties of the first, though of a greater size, the Herefords being the largest. These cattle are the most esteemed of all our breeds for the draught, on account of their activity and hardiness; they do not milk so well as the short-horns, but are not deficient in the valuable property of feeding at an early age, when not employed in labour.

6783. *The Devonshire cattle* (*fig. 857.*) are of a high red colour (if any white spots they reckon the breed impure, particularly if those spots run one into another), with a light-dun ring round the eye, and the muzzle of the same colour, fine in the bone, clean in the neck, horns of a medium length, bent upwards, thin-faced, and fine in the chops, wide in the hips, a tolerable barrel, but rather flat on the sides, tail small, and set on very high; they are thin-skinned, and silky in handling, feed at an early age, or arrive at maturity sooner than most other breeds. (*Culley*, p. 51.) Another author observes, that they are a model for all persons who breed oxen for the yoke. (*Parkinson on Live Stock*, vol. i. p. 112.) The weight of the cows is usually from 30 to 40 stone, and of the oxen from 40 to 60; the North Devon variety, in particular, from the fineness in the grain of the meat, is held in high estimation in Smithfield. (*Dickson's Practical Agriculture*, vol. ii. p. 120.)



6784. *Lawrence* says that the race of red cattle of North Devon and Somerset is doubtless one of our original breeds, and one of those which have preserved most of their primitive form: the excellence of this form for labour is best proved by the fact, that the fashionable substitution of horses has made no progress in the district of these cattle, by their high repute as feeders, and for the superior excellence of their beef, which has been acknowledged for ages. They are, he says, the speediest working-oxen in England, and will trot well in harness; in point of strength, they stand in the fourth or fifth class. They have a greater resemblance to deer than any other breed of neat cattle. They are rather wide than middle-horned, as they are sometimes called; some, however, have regular middle-horns, that is, neither short nor long, turned upward and backward at the points. As milkers, they are so far inferior to both the long and short horns, both in quantity and quality of milk, that they are certainly no objects for the regular dairy, however pleasing and convenient they may be in the private family way.

6785. *The Sussex and Herefordshire cattle* (*fig. 858.*) are of a deep red colour, with fine hair and very thin hides; neck and head clean, the face usually white; horns neither long nor short, rather turning up at the points; in general, they are well made in the hind quarters, wide across the hips, rump, and sirloin, but narrow in the chine; tolerably straight along the back, ribs too flat, thin in the thigh, and bone not large. An ox, six years old, will weigh, when fat, from 60 to 100 stone, the fore-quarters generally the heaviest: the oxen are mostly worked from three to six years old, sometimes till seven, when they are turned off for feeding. The Hereford cattle are next in size to the Yorkshire short-horns: both this and the Gloucester variety are highly eligible as dairy stock, and the



females of the Herefords have been found to fatten better at three years old than any other kind of cattle except the spayed heifers of Norfolk. (*Marshal's Economy of Gloucestershire.*)

6786. *The polled or hornless breeds.* The most numerous and esteemed variety is the Galloway breed (*fig. 859.*), so called from the province of that name, in the south-west of Scotland, where they most abound. The true Galloway bullock "is straight and broad on the back, and nearly level from the head to the rump, broad at the loins, not, however, with hooked bones, or projecting knobs, so that when viewed from above, the whole body appears beautifully rounded; he is long in the quarters, but not broad in the twist; he is deep in the chest, short in the leg, and moderately fine in the bone, clean in the chop and in the neck; his head is of a moderate size, with large rough ears, and full but not prominent eyes, or heavy eyebrows, so that he has a calm though determined look; his well proportioned form is clothed with a loose and mellow skin, adorned with long soft glossy hair." (*Galloway Report*, p. 236.) The prevailing colour is black or dark brindled, and, though they are occasionally found of every



colour, the dark colours are uniformly preferred, from a belief that they are connected with superior hardiness of constitution. The Galloways are rather undersized, not very different from the size of the Devons, but as much less than the long-horns, as the long-horns are less than the short-horns. On the best farms,

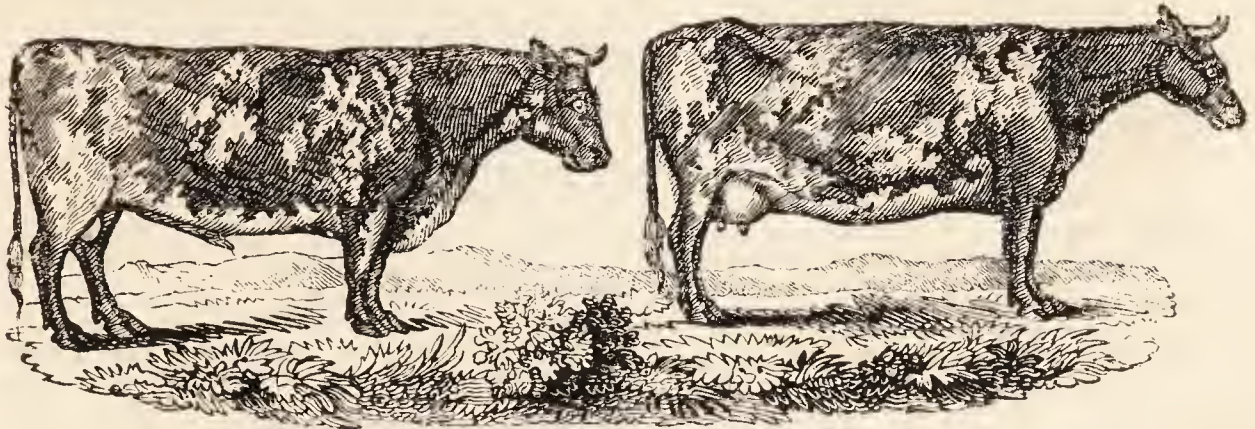
the average weight of bullocks three years and a half old, when the greater part of them are driven to the south, has been stated at about 40 stone, avoirdupois; and some of them, fattened in England, have been brought to nearly 100 stone.

6787. *The general properties of this breed* are well known in almost every part of England, as well as in Scotland. They are sometimes sent from their native pastures directly to Smithfield, a distance of four hundred miles, and sold at once to the butcher; and in spring they are often shown in Norfolk, immediately after their arrival, in as good condition as, or even better than, when they begin their journey; with full feeding, there is perhaps no breed that sooner attains maturity, and their flesh is of the finest quality. Culley was misinformed about the quantity of milk they yield, which, though rich, is by no means abundant. It is alleged not to be more than seventy or eighty years since the Galloways were all horned, and very much the same in external appearance and character with the breed of black cattle which prevailed over the west of Scotland at that period, and which still abounds in perfection, the largest-sized ones in Argyleshire, and the smaller in the Isle of Sky. The Galloway cattle at the time alluded to were coupled with some hornless bulls, of a sort which do not seem now to be accurately known, but which were then brought from Cumberland, the effects of which crossing were thought to be the general loss of horns in the former, and the enlargement of their size: the continuance of a hornless sort being kept up by selecting only such for breeding, or perhaps by other means, as by the practice of eradicating with the knife the horns in their very young state. (*Coventry on Live Stock*, p. 28.)

6788. *The Suffolk duns*, according to Culley, are nothing more than a variety of the Galloway breed. He supposes them to have originated in the intercourse that has long subsisted between the Scotch drovers of Galloway cattle, and the Suffolk and Norfolk graziers who feed them. The Suffolks are chiefly light duns, thus differing from the Galloways, and are considered a very useful kind of little cattle, particularly for the dairy. (*Culley*, p. 66. *Parkinson*, vol. i. p. 116.)

6789. *The Ayrshire breed* (*fig. 860.*), according to Aiton (*Agriculture of Ayr*, p. 421.), is the most improved breed of cattle to be found in the island; not only for the dairy, in which they have no parallel,

860



under similar soil, climate, and relative circumstances; but also in feeding for the shambles. They are, in fact, a breed of cows that have, by crossing, coupling, feeding, and treatment, been improved and brought to a state of perfection, which fits them, above all others yet known, to answer almost in every diversity of situation, where grain and grasses can be raised to feed them, for the purposes of the dairy, or for fattening them for beef. (*Aiton.*)

6790. *The origin of the Ayrshire breed of cattle* is to be found in the indigenous cattle of the county of Ayr, "improved in their size, shapes, and qualities, chiefly by judicious selection, cross-coupling, feeding, and treatment, for a long series of time, and with much judgment and attention, by the industrious inhabitants of the county, and principally by those of the district of Cunningham." (*Aiton.*) The whole dairy breed in the county of Ayr is of mixed white and brown colours.

6791. *The size of the Ayrshire improved dairy cows* "varies from 20 to 40 stones English, according to the quality and abundance of their food. If cattle are too small for the soil, they will soon rise to the size it can maintain; and the reverse, if they are larger than it is calculated to support." (*Aiton.*)

6792. *The shapes most approved of* are as follows:—"Head small, but rather long and narrow at the muzzle; the eye small, but smart and lively; the horns small, clear, crooked, and their roots at considerable distance from each other; neck long and slender, tapering towards the head, with no loose skin below; shoulders thin; fore-quarters light; hind-quarters large; back straight, broad behind, the joints rather loose and open; carcass deep, and pelvis capacious and wide over the hips, with round fleshy buttocks; tail long and small; legs small and short, with firm joints; udder capacious, broad, and square, stretching forward, and neither fleshy, low hung, nor loose; the milk veins large and prominent; teats short, all pointing outwards, and at considerable distance from each other; skin thin and loose; hair soft and woolly; the head, bones, horns, and all parts of least value, small; and the general figure compact and well proportioned." (*Aiton.*)

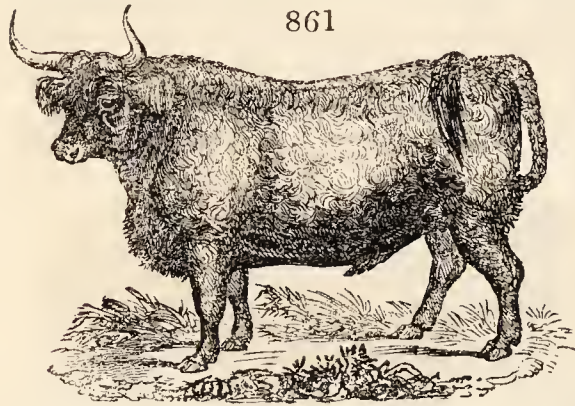
6793. *The form of the Cunninghame Ayrshire cow*, according to Robertson, is "very elegant, but must be seen to be well understood. So far as it may be explained in words, it is thus:—The neck is small, the head little, the muzzle taper, the horns short, curved, and bending upwards; the countenance mild; the body straight along the back from shoulder to tail; the limbs slender; the udder shaped like a well turned punch-bowl, and the paps widely set. The head, the neck, and the udder are the chief distinguishing points. The colour is generally brown, of many hues, from dark to yellow, intermixed and mottled in many a varied form and proportion with white. Some few have a black ground, without any change in character; but almost none are of one colour only. In a whole herd of forty or fifty, there will not two of them be alike in colour, in this respect exhibiting a diversity not unlike to a bed of tulips, and of as many hues and shades, in an endless variety of beauty. The bulls are generally good tempered, and, like the cows, are also mild in the countenance. The usual produce of butter from these cows is ascertained to be about half their own weight (meaning the four quarters) in a year; but this requires that the pasture be good, and the cow otherwise well kept the whole season over." The produce of such a cow so kept will equal 242 lbs. imperial weight per annum of butter, and double that quantity of cheese. The medium produce in butter from Ayrshire milk is from five imperial quarts. (*Rural Recollections*, p. 565.)

6794. *The qualities of an Ayrshire dairy-cow* "are of great importance. Tameness and docility of temper greatly enhance the value of a milch cow. One that is quiet and contented feeds at ease, does not break over fences, or hurt herself and other cattle, will always yield more milk, and is easier to manage, than those that are of a turbulent disposition. To render them docile, they ought to be gently treated; frequently handled when young, and never struck or frightened. Some degree of hardiness, a sound constitution, and a moderate degree of life and spirits, are qualities to be wished for in a dairy cow, and what those of Ayrshire generally possess. The most valuable quality which a dairy cow can possess is that she yields much milk. A cow in Ayrshire that does not milk well will soon come to the hammer. I have never seen cows any where that, under the same mode of feeding and treatment, would yield so much milk as the dairy breed of that district. Ten Scotch pints per day is no way uncommon. Several cows yield, for some time, twelve pints, and some thirteen or fourteen pints per day. Another quality of the

dairy breed of Ayrshire is, that, after they have yielded very large quantities of milk for several years, they are as valuable for beef as the Galloway cow, or any other breed of cows known in Scotland. They fatten as well, and their beef is not inferior to that of any other breed of cattle known in Britain." (*Aiton*.)

6795. *The cattle of the Highlands of Scotland* are divided into a number of local varieties, some of which differ materially from others, probably owing to a difference in the climate and the quality of the herbage, rather than to their being sprung from races originally distinct, or to any great change effected either by selection or by crossing with other breeds. It is only of late that much attention has been paid to their improvement, in any part of this extensive country; and in the northern and central Highlands the cattle are yet, for the most part, in as rude a state, and under management as defective, as they were some centuries ago. These cattle have almost exclusive possession of all that division of Scotland, including the Hebrides, marked off by a line from the Frith of Clyde on the west, to the Murray Frith on the north, and bending towards the east till it approaches in some places very near to the German Ocean. Along the eastern coast, north of the Frith of Forth, the Highland cattle are intermixed with various local breeds, of which they have probably been the basis. There are more or less marked distinctions among the cattle of the different Highland counties; and, in common language, we speak of the Inverness-shire, the Banffshire, &c., cattle, as if they were so many separate breeds; but it is only necessary in this place to notice the two more general varieties, now clearly distinguishable by their form, size, and general properties.

6796. *The most valuable of these are the cattle of the Western Highlands and Isles*, commonly called the *Argyleshire breed* (fig. 861.), or the breed of the Isle of Skye, one of the islands attached to the county of Argyle. The cattle of the Hebrides are called *kyloes*, a name which is often applied in the south to all the varieties of the Highland cattle, not as a late writer (*Dickson's Practical Agriculture*, vol. ii. p. 1124.) has imagined, from the district in Ayrshire called Kyle, where very few of them are kept, but from their crossing, in their progress to the south, the *kyloes* or ferries in the mainland and Western Islands, where these cattle are found in the greatest perfection. (*General Report of Scotland*, vol. iii. p. 26.)



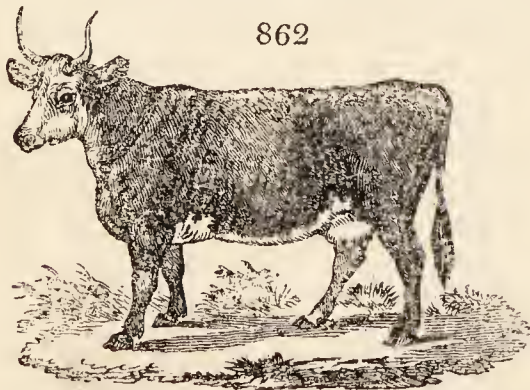
861

6797. *The cattle of Orkney and Zetland* are of a most diminutive size; an ox weighing about sixty pounds a quarter, and a cow forty-five pounds. They are of all colours, and their shapes are generally bad: yet they give a quantity of excellent milk; fatten rapidly when put on good pastures; and, in their own district, are considered strong, hardy, and excellent workers, when well trained to the yoke, and so plentifully fed as to enable them to support labour.

6798. *Of the Fifeshire cattle*, Culley observes, "You would at first imagine them a distinct breed, from their upright white horns, being exceedingly light-lyered and thin-thighed; but I am pretty clear that it is only from their being more nearly allied to the kyloes, and consequently less of the coarse kind of short horns in them. (*Culley*, p. 69.) Notwithstanding this opinion, the cattle of the north-eastern counties of Scotland require, for every useful purpose, to be mentioned separately from the Highland herds; and as all of them have a general resemblance, it will only be necessary in this place to notice the Fife cattle in particular. There are various traditions about the origin of this variety. It is said to have been much improved by English cows sent by Henry VII. to his daughter, the consort of James IV., who usually resided at the palace of Falkland, in that county; and as there is some resemblance between the cattle of Fife and Cambridgeshire, they are supposed to have been brought originally from the latter county. Others ascribe the origin of the present breed to bulls and cows sent by James VI. (James I. of England), in payment of the money which his obliging neighbours in Fife are said to have advanced for his equipment, when he went to take possession of the English throne. (*Report of Nairn and Moray*, p. 305.)

6799. *The prevailing colour of the Fife cattle* is black, though sometimes spotted or streaked with white, and some of them are altogether grey. The horns are small, white, generally pretty erect, or at least turned up at the points, bending rather forward, and not wide spread like the Lancashire long-horned breed. The bone is small in proportion to the carcass; the limbs clean, but short; and the skin soft. They are wide between the hook-bones; the ribs narrow, wide set, and having a great curvature. They fatten quickly, and fill up well at all the choice points; are hardy, fleet, and travel well, and are excellent for labour, both at plough and cart. A good cow of this breed gives from eighteen to twenty-four quarts of milk per day, yielding from seven to nine pounds of butter, and from ten to twelve pounds of cheese per week (twenty-four ounces to the pound), for some months after calving. (*Fife Report*, p. 251. and 253.)

6800. *The cattle of Aberdeenshire*, the largest of which are said to have been produced by crossing with Fife bulls, have been long highly esteemed in the southern markets. It is observed, that every succeeding generation of them has increased in size for the last thirty years; and that the native breed has doubled its former weight since the introduction of turnips. (*Aberdeenshire Report*, p. 468.) The colour is commonly black, but there are many of a red and brindled colour. They are thinner in the buttock, in proportion to their weight; and deeper in the belly, in proportion to their circumference, than the west Highlanders, and they yield a much larger quantity of milk. Many of them are brought to the south of Scotland, and kept during winter in the straw-yards, for which they suit better than smaller cattle, as they are not so impatient of confinement. The ordinary weight of middle-sized oxen, at from three to five years old, is from forty to fifty stone; but after being worked for some time, and thoroughly fattened, they have been known to reach double this weight.



862

6801. *Of the Welsh cattle* (fig. 862.) "there seem to be two distinct kinds. The large sort are of a brown colour, with some white on the rump and shoulders, denoting a cross from the long-horns, though in shape not the least resembling them. They are long in the legs, stand high according to their weight, are thin in the thigh, and rather narrow in the chine; their horns are white and turned upwards; they are light in flesh, and next to the Devons, well formed for the yoke; have very good hoofs, and walk light and nimbly. The other sort are much more valuable; colour black, with very little white; of a good useful form, short in the leg, with round deep bodies; the hide is rather thin, with short hair; they have a likely look, and a good eye; and the bones, though not very small, are neither large nor clumsy; and the cows are

considered good milkers." (*Parkinson on Live Stock*, vol. i. p. 135.)

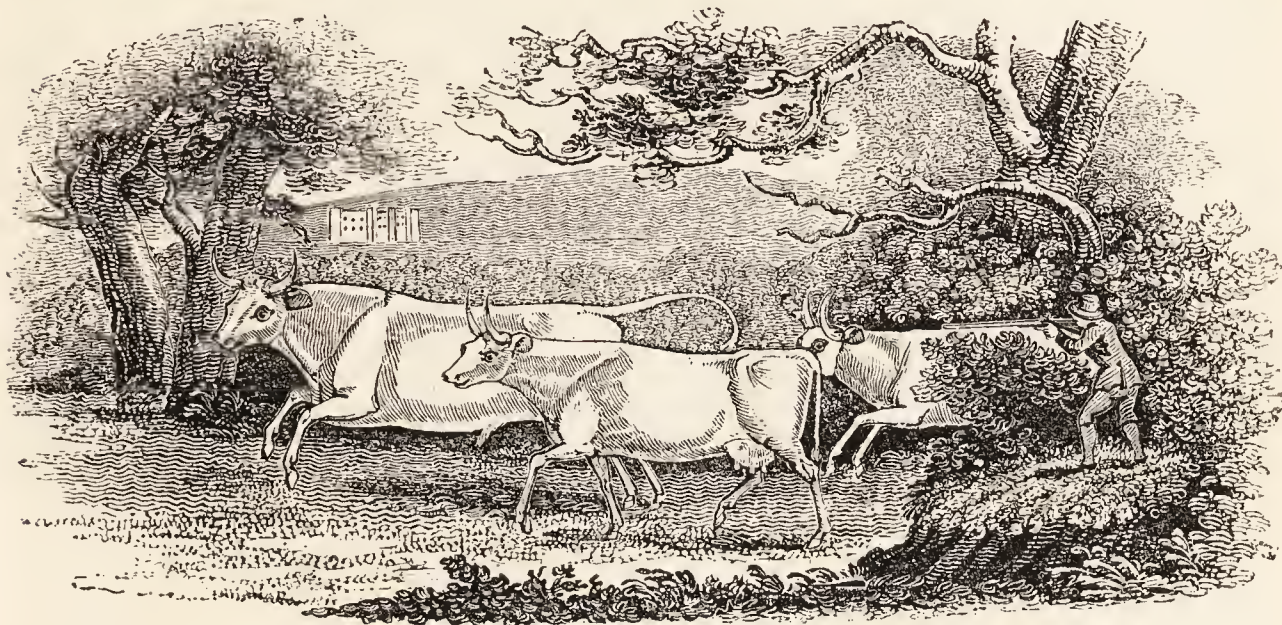
6802. *The Alderney cattle* are to be met with only about the seats of a few great landholders, where they are kept chiefly for the sake of their milk, which is very rich, though small in quantity. This race is considered, by very competent judges, as too delicate and tender to be propagated to any extent in Britain, at least in its northern parts. Their colour is mostly yellow or light red, with white or mottled faces; they have short crumpled horns, are small in size, and very ill-shaped; yet they are fine-boned in

general; and their beef, though high-coloured, is very well flavoured. I have seen, says Culley, some very useful cattle bred from a cross between an Alderney cow and a short-horned bull.

6803. *The Irish cattle*, Culley thinks, are a mixed breed between the long-horns and the Welsh or Scotch, but more inclined to the long-horns, though of less weight than those in England.

6804. The last variety of cattle we shall mention is one entirely of luxury, it is the *wild breed* (fig. 863.) which is found only in the parks of a few great proprietors, who preserve the animals as curious and

863



ornamental, or for the sake of their high-flavoured beef. Those kept at Chillingham Castle, in Northumberland, a seat belonging to the Earl of Tankerville, have been very accurately described in the *Northumberland Report*, and in Culley's book on live stock, so often quoted. Their colour is invariably of a creamy white; muzzle black; the whole of the inside of the ear, and about one third of the outside, from the tips downward, red; horns white, with black tips, very fine, and bent upwards; some of the bulls have a thin upright mane, about an inch and a half or two inches long. The weight of the oxen is from thirty-five to forty-five stone, and the cows from twenty-five to thirty-five stone the four quarters (fourteen pounds to the stone). The beef is finely marbled, and of excellent flavour. From the nature of their pasture, and the frequent agitation they are put into by the curiosity of strangers, it is scarcely to be expected they should get very fat; yet the six years old oxen are generally very good beef, from which it may be fairly supposed that, in proper situations, they would feed well.

6805. *The habits* of these animals are entirely rude; at the first appearance of any person they set off in full gallop, and at the distance of about two hundred yards, make a wheel round and come boldly up again, tossing their heads in a menacing manner; on a sudden they make a full stop, at the distance of forty or fifty yards, looking wildly at the object of their surprise, but, upon the least motion being made, they all again turn round, and fly off with equal speed, but not to the same distance, forming a shorter circle, and again returning with a bolder and more threatening aspect than before; they approach much nearer, probably within thirty yards, when they again make another stand, and again fly off: this they do several times, shortening their distance, and advancing nearer and nearer till they come within such a short distance, that most people think it prudent to leave them, not choosing to provoke them farther.

6806. *When the cows calve*, they hide their calves for a week or ten days in some sequestered situation, and go and suckle them two or three times a day. If any person comes near them, the calves clap their heads close to the ground, and lie like hares in form, to hide themselves. This is a proof of their native wildness, and is corroborated by the following circumstance that happened to the writer of this narrative (Bailey of Chillingham), who found a hidden calf, two days old, very lean and very weak:—On stroking its head it got up, pawed two or three times like an old bull, bellowed very loud, stepped back a few steps, and bolted at his legs with all its force; it then began to paw again, bellowed, stepped back, and bolted as before; but knowing its intention, and stepping aside, it missed him, fell, and was so very weak that it could not rise, though it made several efforts: but it had done enough; the whole herd were alarmed, and, coming to its rescue, obliged him to retire; for the dams will allow no person to touch their calves without attacking him with impetuous ferocity.

6807. *When a calf is to be castrated*, the park-keeper marks the place where it is hid, and when the herd are at a distance, takes an assistant with him on horseback; they tie a handkerchief round the calf's mouth to prevent its bellowing, and then perform the operation in the usual way, with as much expedition as possible. When any one happens to be wounded, or is grown weak and feeble through age or sickness, the rest of the herd set upon it and gore it to death. (Culley, p. 73.)

6808. *The mode of killing them* was, perhaps, the only remains of the grandeur of ancient hunting. On notice being given that a wild bull would be killed on a certain day, the inhabitants of the neighbourhood came mounted and armed with guns, &c. sometimes to the amount of a hundred horse, and four or five hundred foot, who stood upon walls or got into trees, while the horsemen rode off the bull from the rest of the herd, until he stood at bay, when a marksman dismounted and shot. At some of these huntings, twenty or thirty shots have been fired before he was subdued. On such occasions, the bleeding victim grew desperately furious from the smarting of his wounds, and the shouts of savage joy that were echoing from every side; but, from the number of accidents that happened, this dangerous mode has been little practised of late years, the park-keeper alone generally shooting them with a rifled gun at one shot.

SUBJECT. 2. *Criteria of Cattle for various objects and purposes.*

6809. *The criteria of a well-made bull*, to whatever breed he may belong, are, according to Culley, as follows:—The head should be rather long, and the muzzle fine; his eyes lively and prominent, his ears long and thin, his horns wide, his neck rising with a gentle curve from the shoulders, and small and fine where it joins the head; the shoulders moderately broad at the top, joining full to his chine or crops and chest backwards, and to the neck-vein forwards; his bosom open, breast broad, and projecting well before his legs; his arms or fore-thighs muscular, and tapering to his knee; his legs straight, clean, and very fine-boned; his chine and chest so full as to leave no hollows behind the shoulders; the plates strong, to keep his belly from sinking below the level of his breast; his back or loin broad, straight, and flat; his ribs rising one above another in such a manner that the last rib shall be rather the highest, leaving only a

small space to the hips or hooks, the whole forming a round or barrel-like carcass ; his hips should be wide placed, round, or globular, and a little higher than the back ; the quarters from the hip to the rump long, and instead of being square, as recommended by some, they should taper gradually from the hips backward, and the turls or pott-bones not in the least protuberant ; rump close to the tail, the tail broad, well haired, and set on so high as to be in the same horizontal line with his back. Bulls should be constantly well fed, and kept in proper enclosures, never being suffered to ride before they are three years old, as when the contrary is the practice they never attain so perfect a growth. It is observed by Lawrence, that the above description delineates that barrel-shape which Bakewell supposed most advantageous for all kinds of animals intended to be fed for slaughter, or even used for labour.

6810. *The criteria of excellence in neat cattle in general* are thus given by John Wilkinson of Linton, near Nottingham, an eminent breeder. (*Remarks on Cattle, &c.* 1820.) "The head ought to be rather long, and muzzle fine ; the countenance calm and placid, which indicates a disposition to get fat ; the horns fine ; the neck light, particularly where it joins the head ; the breast wide and projecting well before the legs ; the shoulders moderately broad at the top, and the joints well in, and when the animal is in good condition, the chine so full as to leave no hollow behind it ; the fore flank well filled up, and the girth behind the shoulders deep ; the back straight, wide, and flat ; the ribs broad, and the space between them and the hips small ; the flank full and heavy ; the belly well kept in, and not sinking low in the middle, but so formed that a cross section of it would resemble an oval, whose two ends are of the same width, and whose form approaches to that of a circle, or of an ellipsis whose eccentricity is not great (the whole forming, not a round or barrel-like carcass as some have expressed it, for this would leave a deficiency both in the upper and lower part of the ribs) ; the hips globular, wide across, and on a level with the back itself ; the hind quarters, that is, from the hips to the extremity of the rump, long and straight ; the rump points fat, and coming well up to the tail ; the twist wide, and the seam in the middle of it so well filled that the whole may very nearly form a plane perpendicular to the line of the back ; the lower part of the thigh small ; the tail broad and fat towards the top, but the lower part thin ; the legs straight, clean, and fine-boned ; and when the animal is in high condition, the skin of a rich and silky appearance. These appear to be the most material points for the formation of true symmetry in cattle : there are others of a minor consideration, which will readily be suggested by attention and experience."

6811. *The criteria of an ox well adapted to labour* differ from the above only in requiring long and strong legs, and broad hardy feet and hoofs.

6812. *The criteria of a beautiful cow*, according to Wilkinson, may be thus expressed :—

She's long in her face, she's fine in her horn,
She'll quickly get fat, without cake or corn,
She's clear in her jaws, and full in her chine,
She's heavy in flank, and wide in her loin.

She's broad in her ribs, and long in her rump,
A straight and flat back, with never a hump ;
She's wide in her hips, and calm in her eyes,
She's fine in her shoulders, and thin in her thighs.

She's light in her neck, and small in her tail,
She's wide in her breast, and good at the pail,
She's fine in her bone, and silky of skin,
She's a grazier's without, and a butcher's within.

6813. *Culley's marks of a good cow* are these :—Wide horns, a thin head and neck, dewlap large, full breast, broad back, large deep belly ; the udder capacious, but not too fleshy ; the milk-veins prominent, and the bag tending far behind ; teats long and large, buttocks broad and fleshy, tail long and pliable, legs proportionable to the size of the carcass, and the joints short. To these outward marks may be added a gentle disposition, a temper free from any vicious tricks, and perfectly manageable on every occasion. On the other hand, a cow with a thick head and a short neck, prominent back-bone, slender chest, belly tucked up, small udder or fleshy bag, short teats, and thin buttocks, is to be avoided as totally unfit for the purposes either of the dairy-man, the suckler, or the grazier. The most valuable cows are those which are bred in Yorkshire, Staffordshire, and upon the strong lands in other part of England, and in Ayrshire in Scotland.

6814. *The criteria of excellence in cattle, as derived from colour*, are of no importance ; and all that can be said is, that white and red cattle are less hardy than the black-haired.

6815. *The criteria of age in cattle* are derived from the teeth and horns. At the end of about two years they shed their first four teeth, which are replaced by others, larger, but not so white ; and before five years all the incisive teeth are renewed. These teeth are at first equal, long, and pretty white ; but, as the animals advance in years, they wear down, become unequal, and grow black. These animals, according to some, likewise shed their horns at the end of three years ; and they are replaced by other horns, which, like the second teeth, continue ; this, however, is totally or partially denied by practical men, and our statement of it as a fact without qualification has been objected to in the "*American Farmer*." The manner of the growth of these horns is not uniform, nor the shooting of them equal. The first year, that is, the fourth year of the animal's age, two small-pointed horns make their appearance, neatly formed, smooth, and towards the head terminated by a kind of button. The following year this button moves from the head, being impelled by a horny cylinder, which, lengthening in the same manner, is also terminated by another button, and so on ; for the horns continue growing as long as the animal lives. These buttons become annular joints or rings, which are easily distinguished in the horn, and by which the age of the creature may be easily known ; counting three years for the point of the horn, and one for each of the joints or rings. The cow continues useful for more than twenty years, but the bull loses his vigour much sooner. It is common with dealers to obliterate these rings, by shaving the horns, in order to conceal the age of the beast.

6816. *The terms applied to different ages* are as follows :—A young castrated male, after the first year, is called a stirk ; when a year older, a stot, or steer ; at five years old, an ox. A female, after the first year, is called a heifer, or quey ; when about to bring a calf, she is called a young cow. A castrated female is called a spayed heifer. Certain of the Welsh and Scots cattle, of rather a coarse and sturdy kind, are denominated runts. Bullock is the general term for any full-grown male cattle, fat or lean.

6817. *The natural duration of life with the bull and cow* may be stated at upwards of twenty years, to nearly the end of which the latter is useful with her milk, but the former generally loses his vigour, consequently his use, many years sooner.

SUBSECT. 3. *Breeding of Horned Cattle.*

6818. *The objects to be kept in view* in breeding cattle are, forms well adapted for fattening, for producing milk, or for labour. These three objects have each of them engaged the attention of British agriculturists ; but experience has not hitherto justified the expectation that has been entertained of combining all these desirable properties, in an eminent degree, in the same race. That form which indicates the property of yielding the most milk, differs materially from that which we know from experience to be combined with early maturity and the most valuable carcass ; and the breeds which are understood to give the greatest

weight of meat for the food they consume, and to contain the least proportion of offal, are not those which possess, in the highest degree, the strength and activity required in the beasts of labour.

6819. *A disposition to fatten, and a tendency to yield a large quantity of milk, cannot be united.* The form of the animal most remarkable for the first, is very different from that of the other; in place of being flat in the sides, and big in the belly, as all great milkers are, it is high-sided and light-bellied: in a word, the body of the animal well adapted to fatten is barrel-formed, while that of the milker is widest downwards. It is not probable, therefore, that the properties of two breeds of cattle, so opposite in form and general appearance, can ever be united in the same animal.

6820. *The long and short horned breeds* have hitherto been in possession of the best part of the island; but various others, as the Ayrshire, the Galloway cattle, and kyloes, might be bred with advantage in many situations, so as to be more profitable than either the short-horns or the long-horns. These breeds of cattle, as true quick-feeders, and being kindly-fleshed, or excellent eating beef, have established their character in the first market in the island. The Scotch or kyloes are better adapted to cold, exposed, heathy, mountainous situations, than any other breed we have. Particular breeds are probably best adapted to particular situations; on which ground, breeders of cattle should endeavour to find out what breed is the most profitable and best suited to their situations, and to improve that breed to the utmost, rather than to try to unite the particular qualities of two or more distinct breeds by crossing. The latter is a precarious practice; for we generally find the produce inherit the coarseness of both breeds, and rarely attain the good properties which the pure distinct breeds individually possess. In order to have good cattle of any breed, particular regard must be paid in selecting those that are the most complete and perfect in their form, shape, and other qualities, and to breed from them.

6821. *An extraordinary degree of attention* has been paid to the breeding of cattle in England since the time of Bakewell, and some illustrious names might be mentioned in addition to those of professional farmers. Pedigrees of the best cattle have been preserved with no less care, in several places, than those of race horses; and, in the selection of breeders, the properties of the family from which they have descended are matters of scarcely less importance than the form of the young animals themselves. The extraordinary prices paid for the best-bred bulls and cows show that this attention has not been without its reward.

6822. *The best bulls* are either let out for the season, or cows are brought to them at a certain rate per head. The practice of letting bulls is said to have originated with Bakewell (*Marshal's Midland Counties*, vol. i. p. 334.), who, early in his career, let a bull for one hundred and fifty-two guineas, to be used only four months (*Parkinson*, vol. ii. p. 469.); and five guineas per cow were about that time commonly paid to him and other eminent breeders.

6823. *The age at which bulls should begin to be employed*, and the number of seasons they should be allowed to serve, as well as the age at which the females should begin to breed, are points regarding which practice is by no means uniform. In the midland counties, the bulls are pretty commonly allowed to leap while yearlings; and if good stock-getters are kept on as long as they will do business, perhaps till they are ten or twelve years old. In other places they are employed only three seasons, for the first time at two years old. The females, in many instances, bring their first calf at the age of two years, but more commonly, perhaps, not till they are a year older; and in some of the Highland districts, where, owing to a want of proper nourishment in their infancy, they are later in coming to their full growth, the females do not often become mothers till they are about four years old.

6824. *The period of gestation with cows* has been found, upon an average of a great number of experiments, to be about forty weeks. M. Tessier communicated to the National Institute of France the following observations on this subject:—Of 160 cows, 14 calved from the 241st to the 266th day; 3 on the 270th; 50 on the 280th; 68 on from the 280th to the 290th; 20 on the 300th; and 5 on the 308th. Cows seldom bring more than one calf at a time. When they produce twins, one of them a male and the other a female, the latter, which is called a free martin, is commonly considered to be incapable of procreation; yet there seem to have been well authenticated instances to the contrary. (*Farmer's Magazine*, vol. vii. p. 462.; and vol. viii. p. 466.)

6825. *The most desirable period for putting cows to the bull* is midsummer, in order that they may be dropped in spring, and have the whole of the grass season before them. Where no regular system is followed, and cows are sent to the bull merely because they are in heat, calves will be dropped at all seasons; but, except in those districts where the fattening of calves is an object of importance, spring is probably the most advantageous time; as the calves, having all the grass season before them, become sufficiently strong for enduring the change to a less agreeable food in the ensuing winter. A calf newly weaned seldom thrives well during that period, unless it is pampered with better food than usually falls to the share of young animals. By midsummer the cows are readier to take the bull than at any other season, and will bring calves in proper time. If a cow goes till after May before she calves, the calf will be too weak in the winter following; and the dam will not be so ready to take the bull again, but will often grow barren.

6826. *It is not always the best milch cow that has the best calf*, even though the external circumstances should be similar; and *vice versa*, a sorry cow may have a good calf. These remarks apply to this breed as well as to others. The immediate progeny of a good milker may be an indifferent milch cow; but in the second remove, the good milking quality of the grandam returns. This has often been observed, and without any of the causes being imputable to the size. (*Robertson*, p. 571.)

SUBJECT. 4. *Rearing of Horned Cattle.*

6827. *The mode of rearing calves* is various. There can be little doubt but that the best and most natural mode is that of allowing them to suck their dams, at least for some length of time after they are brought forth.

6828. *In Yorkshire, and most parts of Scotland*, the usual method is to give them milk to drink, there being few instances where they are allowed to suck. For the first two or three weeks, they mostly get milk warm from the cow; but for the next two or three weeks, half the new milk is withdrawn, and skim-milk substituted in its stead; and at the end of that period, the new milk is wholly withdrawn: they are then fed on skim-milk alone, or sometimes mixed with water, till they are able to support themselves by eating grass, or other food of that sort.

6829. *In Cheshire*, the practice is to allow the calves to suck for the first three weeks. They are then fed on warm new whey, or scalded whey and buttermilk mixed; with the green whey water is frequently mixed, and either oatmeal or wheat and bean flour added. A quart of meal or flour is thought sufficient to mix with forty or fifty quarts of liquid. Oatmeal gruel and buttermilk, with an addition of skimmed milk, are also used for the same purpose. Some one of these prepared kinds of food is given, night and morning, for a few weeks after the calves are put on that diet, but afterwards only once a day till they are three months old or more.

6830. *In Gloucestershire* the calves are not allowed to suck above two or three days; they are then fed on skim-milk, which is previously heated over the fire. When they arrive at such an age as to be able to eat a little, they are allowed split beans, or oats and cut hay, and water is mixed with the milk.

6831. *In Sussex* it is common to allow the calves to suck for ten or twelve weeks, or to wean them at the end of three or four, and give them a liberal allowance of skim-milk for six or eight weeks longer.

6832. *In Middlesex* it is usual, in rearing calves, to give them a pailful, containing about a gallon, of milk warm from the cow, morning and evening, for eight or ten weeks; or, which is certainly the most

agrecable to nature, and therefore to be preferred to any other that can be adopted, to allow the calf to suck its dam, as it is sometimes done in the county of Sussex, and generally in Wigtonshire.

6833. *According to Marshal*, the best method is this:—The calves suck a week or a fortnight, *according to their strength* (a good rule); new milk in the pail, a few meals; next, new milk and skim-milk mixed, a few meals more; then, skim-milk alone, or porridge made with milk, water, ground oats, &c. and sometimes oil-cake, until cheese-making commences; after which, whey porridge, or sweet whey, in the field; being careful to house them in the night, until warm weather be confirmed. (*Midland Counties*, vol. i. p. 338.) This method of suckling is not, however, free from objection; and, in the ordinary practice of rearing calves, it is held to be a preferable plan to begin at once to teach them to drink from a pail. The calf that is fed from the teat must depend upon the milk of its dam, however scanty or irregular it may be; whereas, when fed from a dish, the quantity can be regulated according to its age; and various substitutes may be resorted to, by which a great part of the milk is saved for other purposes, or a greater number of calves reared upon the same quantity. (*General Report of Scotland*, vol. iii. p. 51.) Yet it would seem to be a good practice to allow calves to suck for a few days at first, if there were no inconvenience to be apprehended, both to themselves and their dams, from the separation afterwards.

6834. *When fed from the pail*, the average allowance to a calf is about two English wine gallons of milk daily, for twelve or thirteen weeks; at first, fresh milk as it is drawn from the cow, and afterwards skim-milk. But after it is three or four weeks old, a great variety of substitutes for milk are used in different places, of which linseed-oil cake, meal, and turnips, are the most common.

6835. *Where calves are reared with skim-milk*, it should be boiled, and suffered to stand until it cools to the temperature of that first given by the cow, or a trifling degree more warm, and in that state it should be given to the calf. Milk is frequently given to calves warm only; but that method will not succeed so well as boiling it. If the milk be given over-cold, it will cause the calf to skit or purge. When this is the case, put two or three spoonfuls of rennet in the milk, and it will soon stop the looseness. If, on the contrary, the calf is bound, bacon-broth is a very good and safe thing to put into the milk. One gallon of milk per day will keep a calf well at first. The usual allowance is about double after the first eight or ten days, and this is increased with the age of the animal. After it is thirteen weeks old, it will do very well upon grass or other food, without any milk at all. A calf may then be supported without milk, by giving it hay, and a little wheat-bran, once a day, with about a pint of oats. The oats will be found of great service as soon as the calf is capable of eating them. The bran and oats should be given about mid-day; the milk in portions, at eight o'clock in the morning, and four in the afternoon. But whatever hours are chosen to be set apart for feeding the calf, it is best to adhere to the particular times, as regularity is of more consequence than many people think. If the calf go but an hour or two beyond his usual time of feeding, he will find himself uneasy, and pine for food. It is always to be understood, that calves reared in this manner are to be enticed to eat hay as early as possible; and the best way of doing this is to give them the sweetest hay that can be got, and but little at a time. Turnips or potatoes are very good food, as soon as they can be eaten by them; and they are best cut small, and mixed with hay, oats, bran, and such articles. It may be observed, that it is not absolutely necessary to give milk to calves after they are one month old: to wean them gradually, two quarts of milk, with the addition of linseed boiled in water to make a gruel, given together, will answer; and by diminishing the milk gradually, the calf will soon do without it. Hay tea will do, with the like addition of two quarts of milk; but it is not so nutritious as linseed. It is a good method of making this, to put such a proportion of hay as will be necessary into a tub, then to pour on a sufficient quantity of boiling water, covering up the vessel, and letting the water remain long enough to extract the virtues of the hay. When bacon or pork is boiled, it is a good way to preserve the liquor or broth, and mix it with milk for the calves.

6836. *In summer, calves may sometimes be reared on whey only*; but, when reared in winter, they must be fed with hay; and clover-hay is probably the best of any for this use. Calves may also be raised with porridge of different kinds, without any mixture of milk. It is sometimes a good and convenient plan, the author of the *New Farmer's Calendar* says, to bring up calves under a step-mother; an old cow, with a tolerable stock of milk, will suckle two calves, or more, either turned off with her, or at home, keeping them in good condition, until they are old enough to shift: they ought to suck the first of their mother's milk for two or three days, although many are weaned without ever being suffered to suck at all. Calves, whether rearing or fattening, should also always suck before milking, the cow being milked afterwards, as the first and thinnest of the milk is sufficiently rich. Old milk will, perhaps, scour a very young calf; but the effect will go off without any ill consequences. He observes, that the Duke of Northumberland's recipe is to take one gallon of skimmed milk, and to about a pint of it add half an ounce of common treacle, stirring it until it is well mixed; then to take one ounce of linseed-oil cake, finely pulverised, and with the hand let it fall gradually, in very small quantities, into the milk, stirring it in the mean time with a spoon or ladle, until it be thoroughly incorporated; then let the mixture be put into the other part of the milk, and the whole be made nearly as warm as new milk when it is first taken from the cow; and in that state it is fit for use. The quantity of oil-cake powder may, from time to time, be increased as occasion may require, and as the calf becomes inured to the flavour of it. Crook's method is to make a jelly of one quart of linseed, boiled ten minutes in six quarts of water, which jelly is afterwards mixed with a small quantity of the best hay tea. On this he rears many calves without milk: he thinks many calves are annually lost by artificial rearing, and more brought up with poor and weak constitutions.

6837. *When calves are dropped during the grass season*, Donaldson observes, they should be put into some small home-close of sweet rich pasture after they are eight or ten days old, not only for the sake of exercise, but also that they may the sooner take to the eating of grass. When they happen to be dropped during winter, or before the return of the grass season, a little short soft hay or straw, or sliced turnips, should be laid in the trough or stall before them.

6838. *Castration* is performed both on male and female calves, when neither are intended for procreation. On cow calves, however, it is generally omitted: but in Norfolk no distinction is made as to sex; males and females are equally objects of rearing, and are both occasionally subject to castration, it being a prevailing custom to spay all heifers intended to be fatted at three years old; but such as are intended to be finished at two years old are, it is believed, pretty generally left "open;" as are, of course, those intended for the dairy. There are two reasons for this practice: they are prevented from taking the bull too early, and thereby frustrating the main intention; and by this precaution may lie more quietly, and are kept from roving at the time of fattening. This may be one reason why spayed heifers are thought to fatten more kindly at three years old, and to be better fleshed, than open heifers.

6839. *The time of performing the operation of castration* in horned cattle, as in all kinds of live stock, is while the animals are yet very young, and just so strong as to endure this severe operation without any great danger of its proving fatal. The males, accordingly, are cut commonly when about a month old, and the females at the age of from one to three months; but in Galloway, where more heifers are *spayed* than perhaps in all the island besides, this is seldom done till they are about a year old.

6840. *The best time for rearing calves* is the spring; but that operation must depend in some degree on the time when the calf was dropped. Such as are weaned during autumn or winter, however, seldom do any good. At the season when the calf is weaned from the teat, it ought to be turned abroad, in the day-time, into a small close or orchard near the yard where there is a good bite of grass, which may be expected at the time of the year when the weaning-calves are of this age; and, as there will generally be more than one calf weaned in a season, they will each be company for the other and become in a short time reconciled to their situation. It is to be observed, that this pasture should be at some distance from that whereon the dams are turned, and that there be neither ponds nor ditches, nor any annoyance which might endanger the lives of these youthful animals; and, in order to habituate them still more

to their pasture, milk-pottage should be carried to them at each of their feeding hours. For the first month or six weeks, the calves ought every night to be brought out of the meadow, and lodged in the pens; but after this time they may be left in the pasture as well in the night season as in the day; and at this time their food may be lowered by degrees, till it be at length reduced to simple water only; for, when the calves get to the age of twelve or fourteen weeks, they will no longer require the aid of this sustenance, but will be able to satisfy their appetites with grass. Care, however, must be taken throughout the summer that they be frequently shifted from one pasture to another, in order that they may be kept up in good flesh, and enabled to grow away with the utmost celerity. At Michaelmas, or soon after, the calves should be taken into the yard; and if they were allowed the indulgence of a small close to themselves it would be still better.

6841. *The treatment of young cattle*, from the time they are separated from their dams or are able to subsist on the common food of the other stock, must entirely depend upon the circumstances of the farm on which they are reared. In summer, their pasture is often coarse, but abundant; and in winter all good breeders give them an allowance of succulent food along with their dry fodder. The first winter they have hay and turnips; the following summer coarse pasture; the second winter straw in the fold-yard, and a few turnips once a day, in an adjoining field, just sufficient to prevent the straw from binding them too much; the next summer tolerably good pasture; and the third winter as many turnips as they can eat, and are in every respect treated as fattening cattle. (*Culley*, p. 47.)

6842. *The method of managing young cattle* during the first winter is, according to Donaldson, pretty generally the same in every part of the island. They are generally housed: sometimes bound up to the stall; but more frequently allowed to remain at freedom. The way of feeding them in England is chiefly with hay or hay and straw mixed; and in Scotland sometimes with hay, but more frequently straw and turnips. They are mostly turned out on some of the inferior pastures on the farm in the following summer, and maintained the second winter on straw in the straw-yard, or in houses or sheds erected for the purpose. Some farmers in the more northern parts of the kingdom, from being situated at a distance from any market at which they can dispose of stall-fed beef, very frequently give a considerable part of their turnip-crop to their young cattle. This is, he thinks, an excellent practice; and one that ought to be followed, even by those who, from being better situated with regard to markets, can adopt other methods of using turnips to advantage. The benefit of green winter food for live-stock is so great, that there is probably, he says, no way in which turnips can be used, by which the farm or the farmer would reap greater benefit, than by giving the young cattle a daily allowance during the first two or three winters.

SUBJECT. 5. *Fattening Calves by Suckling.*

6843. *The most advantageous stock for suckling calves* for the butcher is that sort of cow which gives the greatest quantity of milk, richness of quality being not so great an object, or so well adapted to the desired purpose. The Holderness cows are to be preferred in this view; not, however, to suckle calves of the same, but of a smaller breed: perhaps Devon calves surpass all others as sucklers, whether for quickness of proof, or beauty of the veal; they are not, however, to be procured but in or near their own country.

6844. *The method most commonly employed in fattening calves* is, to allow them to suck; as by this method the object is probably not only sooner, but more effectually attained than by any other means. The period which is necessary for fattening calves in this way must be different, according to circumstances, but it is generally from seven to nine weeks; however, in the dairy districts, where milk is considered a valuable article, scarcely half that time is allowed. There is another method, which is, to give them the milk to drink; and when that is done, it is given them morning and evening warm from the cow, and the quantity increased according to their age and strength. In whatever way they may be managed, they should be kept in pens in a close house, and well littered. The author of the *Synopsis of Husbandry* observes, that as it is necessary that the calves should lie always quiet, in order that they may indulge in sleep at those times when they are not employed in sucking, it seems proper that the cow-house should be situated in the most retired part of the yard, and that the pens should be kept as dark as possible. But notwithstanding this caution, the calves should by no means be suffered to lie too hot in the summer time, which would be apt to produce a sickness amongst them. To admit, therefore, an occasional draught of fresh air, let a window be cut in each pen, with shutters adapted to the same, and let these windows be opened whenever the closeness of the atmosphere indicates it to be necessary. In the summer season, they should rarely, if ever, be closely shut; and when it is required, the stream of air may be increased by opening the cow-house door at the opposite end of the building. Each calf should have a collar round his neck, with which the attendant may direct him in his sucking, but should never be fastened up in the pen. It is necessary that the pens be kept constantly well littered with the cleanest wheat straw, a proportion of which should be thrown in to them every day; cleanliness being a most essential article in the fattening of every animal, and not more necessary to any than to the calf, which, but for this precaution, would in a short time demonstrate the ill effects of lying on his accumulated dung, which of all animals is the most offensive and of a quality highly septie. As the calves are weaned, they are to be taken into the pens, and suckled by their own dams, which at first will yield a far greater quantity of milk than is necessary for their offspring, so that another calf may be suckled thereon; or the cow may be milked, and the cream be reserved for butter, or applied to any other use that the owner may think proper. As the calf increases in size, it will require a larger quantity of milk; but whilst calves are young, one good cow will yield a noble supply for two; and when the whole produce is demanded for one calf, another new milk cow should be provided, and these two cows will abundantly supply the three calves with milk till the oldest is fit for the butcher; after which, if necessary, a fresh suckler may be brought in, and the business be carried on progressively by keeping the house constantly supplied with calves, so that the whole milk may be sucked, as the dairy and the fattening of calves by suckling cannot be conveniently united.

6845. *The only advantage which suckling can have, over giving calves milk to drink*, is, that the action of sucking induces "a greater secretion of saliva, which, by promoting digestion, accelerates the growth and fattening of the young animal, cannot be doubted; but the secretion of that fluid may be likewise promoted, by placing an artificial teat in the mouth of the calf, and giving it the milk daily and at the natural temperature. In the dairy districts of Scotland, the dairy-maid puts one of her fingers into the mouth of the calf when it is fed, which serves the purpose of a teat, and will have nearly the same effect as a natural teat, in inducing the secretion of saliva. If that, or an artificial teat of leather, be used, and the milk given slowly before it is cold, the secretion of saliva may be promoted to all the extent that can be necessary; besides that secretion is not confined to the mere period of eating, but, as in the human body, the saliva is formed, and part of it swallowed at all times. (*Aiton's Dairy Husbandry*, p. 87.)

6846. *Young calves, when permitted to suck their fill*, are often seized with a lax or seouring: to prevent which, the calves for the first fortnight or three weeks may be stinted in their allowance; and at the same time due care should be taken that they do not pine or decrease in flesh for want of milk. But after this age they should be allowed to suck as long as they choose; and every means ought to be made use of to increase their appetite, and render them more eager after their food. Chalk may be given for this purpose, as well as for giving to the flesh a delicate whiteness. An excellent astringent remedy has been already given. (6552.) Salt sprinkled in the trough will likewise act as a stimulant to the appetite; besides which, it is a common practice with some people to cram their calves with balls compounded of flour, powdered chalk, and milk, with the addition of a small quantity of common gin. Of these balls they give

two, about the size of a walnut, once a day, or oftener, to each calf. These balls, being very nutritious, in some degree supply the place of milk, and at the same time the spirituous mixture operates on the creatures as a soporific, and thus, by composing them to sleep, increases their disposition to fatten; but where milk can be had in sufficient abundance, it is never worth while to have recourse to these factitious aids. When the demands of the calf, however, are beyond the ability of the cow, these balls come seasonably to their relief. In order that the calves may be provided with sufficient store of milk, the pastures should be changed, whenever the cows are found to be deficient in this particular; and in the winter time, such food as is of a succulent nature, as grains, turnips, &c., should be always at hand to supply the want of grass; and these, with a due allowance of the sweetest hay, should be their constant aliment during the time that the cows are confined to the yard.

6847. *The prices of suckling calves* vary according to the goodness of the young animal, and the time of year wherein the purchase is made. In general, sucklers fetch the largest price in summer, when veal sells the cheapest; and the reason of this arises from the smaller number to be met with at that time than in the spring. When calves are slaughtered at six weeks or two months old, the veal is seldom of a good colour; neither has the flesh of these young calves a taste equal to that of animals suffered to live a few weeks longer. To attain colour and flavour, it is necessary that the calves should be maintained with plenty of milk, and managed as before directed, till they arrive at the age of eight or ten weeks, according to the season of the year, the more or less kindly state of the calf, the particular demand of the markets, or other accidental circumstances. In the summer season, it may be proper to dispose of them at an earlier period than in the winter; not only on account of their growing away with greater celerity in warm weather, but likewise because of the increased demand for small veal, which is then most saleable. During the last three or four weeks, blood should frequently be drawn from the calf, which will be a likely means towards rendering the veal of a colour delicately white; a circumstance so much attended to by the butcher, that he will commonly depreciate such calves as, from the appearance of their eyes, are likely to die black, as they term it, though in other respects not to be despised.

6848. *Calves suckled on their own dams* will, generally speaking, fatten in a shorter time than those afterwards brought in to supply their places. The first obvious reason for this difference in their favour is, their having been permitted to remain in the place where they were first dropped, and having always continued to suck the milk of their dam, which must in all reason be supposed of a more nutritious quality to them than that of any other cow. Secondly, the cow having so lately calved, the aliment nourishes and fattens in a higher degree than when the animal becomes stale-milched. Cow calves are observed to fatten more kindly than the male or bull-calves; and the latter are much coarser grained than the former, and their flesh less delicate in taste. Calves of the largest size are fattened in Essex, where the business of suckling seems to be better understood, and more properly conducted, than in any other county, and where the farmer keeps the calves to a greater age than in any other part of the kingdom.

6849. *Marshal* is clearly of opinion, that to suckle calves in general after they are ten weeks old is bad management; for his account in this respect is uniform, those of nine or ten having paid as much a week as those of twelve or thirteen; and, although a calf of six weeks old may suck nearly as much milk as a calf of twelve weeks old, yet for the first month or five weeks the quantity is considerably less, and this advantage of their infancy is doubly as valuable to nine as it is to twelve weeks. There can be no doubt but that the profit of this system of fattening depends materially upon the quickness of return.

6850. *In some districts*, barley-meal, linseed boiled into a kind of jelly, and similar articles, are given to calves in the course of fattening; but the methods above described are greatly superior, although it must be allowed that they may sometimes be considerably more expensive.

6851. *The art of fattening calves for the butcher* is practised in the parish of Avondale or Strathaven, with a degree of success, according to Aiton, which has had no parallel in Scotland. The superior excellence of the Strathaven veal has long been proverbial in the Glasgow and Edinburgh markets, where Strathaven veal and that of the best quality have become synonymous terms. The mode of feeding them is easy and natural. They are fed on milk, with seldom any admixture; and they are not permitted to suckle their dams, but are taught to drink the milk from a dish. The only art used in feeding calves in the vicinity of Strathaven is, to give them, after the first two or three weeks, *abundance of milk*; to keep plenty of dry litter under them, in a place that is *well aired*, neither too hot nor too cold; and to *exclude the light*, as they are apt to become too sportive when exposed to much light. If a calf becomes *costive*, a little bacon or mutton broth will give it ease; and if it begins to purge, a small quantity of the rennet used in coagulating milk will cure the disease. (*Aiton's Dairy Husbandry*, p. 89.)

SUBSECT. 6. *Fattening Horned Cattle.*

6852. *The fattening of cattle demands considerable and constant attention*, and the grand object is to fatten quickly. An animal when in a state of rearing may be considered as a vessel open at both ends, in which the supply and the waste being nearly equal it can never be filled: fattening an animal may be considered as an attempt to fill the vessel, and this can only be done by excess of supply. The waste being the same as before, this excess must be great; if it is not so, the vessel may be filled to a greater height than before without ever becoming full. An important hint might be taken from this simile by many farmers, who know little of the difference between feeding and fattening. We have known cattle, sheep, and swine kept for months, and fed with a view to fattening them, without their gaining a pound of meat.

6853. *The food on which cattle is fatted* in summer is grass, commonly on pastures, but, in a few instances, cut and consumed in feeding-houses or fold-yards: in winter by far the greater number are fatted on turnips, along with hay or straw; oil-cake, carrots, potatoes, and other articles of food, are used occasionally, and in particular districts, oil-cake chiefly for feeding the larger animals; but few, comparatively, are fatted on any of these without the addition of turnips of one or other of the varieties generally cultivated. A considerable number of cattle are also fatted on the offals of distilleries, when distilling from corn; a source of supply, the frequent interruption of which has been much felt in those situations where the soil does not permit the extensive cultivation of turnips. It is seldom or never the practice of the best managers to fatten cattle with roots or other winter food on the field, during that season; but to confine them to houses or fold-yards, where they are well littered, regularly fed, not liable to be disturbed, and sheltered from the inclemency of the weather, and where the manure they make is an object of very considerable importance, and of much greater value than if it were dropped at random over a whole field.

6854. *The age at which cattle are fatted* depends upon the manner in which they have been reared; upon the properties of the breed in regard to a propensity to fatten earlier or later in life; and on the circumstances of their being employed in breeding, in labour, for the dairy, or reared solely for the butcher. In the latter case, the most improved breeds are fit for the shambles when about three years old, and very few of any large breed are kept more than a year longer. As to cows and working oxen, the age of fattening must necessarily be more indefinite; in most instances the latter are put up to feed after working three years, or in the seventh or eighth year of their age. In general, it may be said, that the small breeds of cattle are fatted on pastures, though sometimes finished off on a few weeks' turnips; and that large cattle, at least in the north, are chiefly fatted in stalls or fold-yards, by means of turnips, and the other articles before mentioned.

6855. *Stall-feeding* is the most common, and, when judiciously conducted, probably the most eligible method, in regard to the cattle themselves, the economy of food, and the expense of farm buildings. The small shed and fold-yard, called a *hammel* (2831.), are used only for the larger breeds; but they do not

seem well calculated for an extensive system of fattening by those who do not breed, but purchase stock every year from different parts. (*Sup. E. Brit. art. Agr.*)

6856. *The two great points in feeding animals to proof*, according to the author of the *Farmer's Calendar*, are, regularity, and a particular care of the weaker individuals. On the latter account there ought ever to be plenty of trough or rack room, that too many may not feed together; in which very common case the weaker are not only trampled down by the stronger, but they are worried, and become cowed and spiritless, than which there cannot be a more unfavourable state for thriving; besides, these are ever compelled to shift with the worst part of the meat. This domineering spirit is so remarkably prevalent amongst horned cattle, that he has a hundred times observed the master-beasts running from crib to crib, and absolutely neglecting their own provender for the sake of driving the inferior from theirs. This is, much oftener than suspected, the chief reason of that difference so visible in a lot of beasts, after a winter's keep. It is likewise, he says, a very common and very shameful sight, in a dairy of cows, to see several of them gored and wounded in a dozen places, merely from the inattention of the owner, and the neglect of tipping the horns of those that butt. The weaker animals should be withdrawn and fed apart; and, in crib-feeding in the yard, it is a good method to tie up the master-beasts at their meals.

6857. *Fattening cattle*, Donaldson observes, are usually put to grass in May or June, according to the season and situation in regard to climate. The period necessary for fattening an ox for the butcher depends on several circumstances; as the condition he was in when put to grass, the nature of the pasture, and many others; but, in ordinary cases, an ox will be completely fattened in three months. There is, he says, one method of fattening, connected with the grazing system, that the farmers in England are, from the superior excellence of the climate, enabled to adopt with success, which can never be attempted with propriety in Scotland. It is very common, at the close of the grass season, when the fattening stock happens not to be fully in condition for the butcher, to render them so, by giving them hay two or three times a day in the field, or in hovels erected for the purpose, into which they have access at pleasure.

6858. *When turnips are employed for the purpose of fattening cattle*, especially if they are put up to the stalls in proper condition, which, considering the season of the year (November), must, with ordinary attention, always be the case, from ten to thirteen weeks is fully sufficient to render them fit for market.

6859. *The fattening of cattle with grains* may, in some respects, be considered as a branch of the distillery business; but yet there are some instances wherein those who cultivate farms practise it with a double view—the obtaining of a profit on the sale of cattle, and the acquisition of a valuable treasure of useful manure. Adam, the renter of the farm of Mount Nod, near Streatham, in the county of Surrey, erected a very complete building, for the purpose chiefly of fattening cattle on grains. In this building might sometimes be seen several hundred head of cattle.

6860. *The method of fattening cattle with oil-cake, corn, cut chaff, &c.* is practised in many of the English counties, with a degree of success sufficient to warrant farmers in other parts of the island to follow the same practice. The cattle are commonly put up to fatten at the end of the grass season. The usual allowance of oil-cake, after it is broken in a large mortar, or, in the fruit districts, in a cyder-mill, is about half a peck per day, one half in the morning, and the other in the evening; to which is added hay, and in some cases ground corn, that is, oats or barley of inferior quality, and cut straw, provincially “chaff.” As bullocks fattened in this manner get regularly five, and sometimes six, meals a day, it is sufficiently evident that, although it may be, upon the whole, an expensive mode of fattening, yet it must be both expeditious and effectual.

6861. *Booth's establishment for fattening cattle at Brentford* is one of the most extensive in the neighbourhood of London. It was formed for the purpose of consuming on the spot the grains and wash of the extensive distillery of that family. The building is 210 feet long, and 180 feet wide; and calculated to contain 600 head of cattle. It cost 8000*l.* The side walls are about 10 feet high, with 20 windows on each side, and 8 windows at each end, not glazed, and a few glazed skylights in the roof. The roof forms one ridge, and the centre part of it affords space for an ample hay-loft; it is supported by cast-iron and wooden pillars, so numerous as to have the appearance, on first entrance, of a forest of columns. A passage of six feet, the centre of which is paved with plates of cast-iron, is continued round the whole building, and between every two rows of cattle are passages of the same width and description. The whole is lighted by thirty-six gas-lights. The cattle stand in stalls seven feet and a half wide; and the space from the manger to the gutter behind the cattle is about ten feet: the gutters have an inclination to one end, and there are also underground drains having a similar inclination, into which the liquid from the gutters runs through iron gratings. There is a common manger which extends the whole length of each row of cattle, the bottom of which is on a perfect level. The portion of this manger contained in every double stall has a second bottom, with two ends let into it, the second or upper bottom descending to within three inches of the bottom common to the whole manger. In the upper trough so formed, and which, in length, occupies about half of the length of the portion of the manger belonging to each stall, is put the grains, or other solid food; the common manger being for the re-

ception of the wash, or other liquid food or drink. The immense quantity of wash produced by the distillery is kept in a cistern or tank above the level of these mangers, and in a different part of the premises; but pipes from this tank are conducted under the surface and communicate with each of them, so that by turning a cock the whole of the cattle in any one of the ranges are instantly supplied with wash. This article serves both as food and drink, as it contains the finer particles of the ground malt, and the greater part of the barley meal used in the mashing process. The grains are kept in deep pits about twelve feet square, and ten or twelve feet deep, somewhat narrower at bottom than at top, lined with brick set in cement; and when the grains are trodden in, and raised like the ridge of a house, they are covered with road stuff to exclude the air, and protect them from the weather. Little or no litter is used, and neither green food nor hay uncut is ever given. Oil-cake is used, but not always; it being found that rough clover chaff mixed with the grains and wash will fatten to any extent.

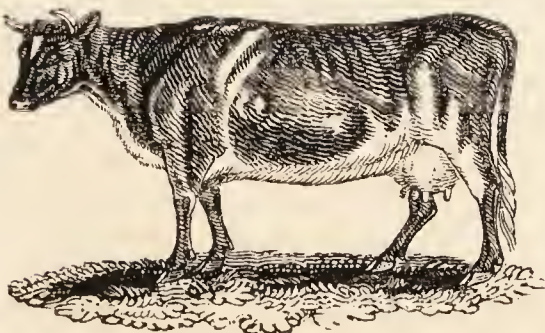
6862. *This building*, though erected at great expense, is very unsightly, and far from complete. It is much too cold in winter from the openness of the roof, and, exteriorly, very displeasing to the eye from its great height. Within, the view is utterly disfigured by seemingly innumerable posts, three fourths of which are of little or no use. For one third part of the cost an equally useful, and much handsomer structure might have been erected. It has never paid a profit to its owners, who, if they could sell their wash and grains at the present market price, calculate that their profits would be considerably greater than by consuming it on the premises.

SUBJECT. 7. *Management of Cows kept for the Dairy.*

6863. *Milch cows* are kept for the manufacture of butter and cheese, for the suckling of calves for the butcher, and for the immediate use of the milk.

6864. *The kind of cow used by the dairymen* who supply the London market is chiefly the Holderness, a variety of the short-horned breed, with large carcasses and short horns. They are bred chiefly in Yorkshire and Durham; but in part in most counties. The Edinburgh dairies are supplied by short-horned cows from Roxburghshire, and other pastoral districts in the south of Scotland. For private dairies, the

864



variety bred in Ayrshire (*fig.* 864.) have a decided preference, as giving a rich milk and large proportion of butter; and the cheese made from the milk of this breed, known as Dunlop, is decidedly celebrated. In Lancashire, the native long-horned breed is said, in the Report of that county, to obtain the general preference: but in Hodgson's dairy at Caton, in the same district, it was found that a short-horned cow, upon an average of twelve months, will yield nine quarts of milk in the day, and four and a half pounds of butter in the week; and a long-horned cow gives eight quarts of milk in the day, and four pounds of butter in the week, for the same period. The cows of both kinds had constantly the same kind of food; but, in order to have the clear result, the quantity of food consumed by each cow of the different breed should have been fully ascertained. The produce of milk and butter is on the side of the short-

horned sort ; but it is not ascertained whether the neat balance is in favour of the short or long-horned. (*Lancashire Rep.* 561.) The Guernsey breed is valued by some for the richness of the cream and butter ; but, both for the dairy and butcher, it is very unprofitable.

6865. *Where butter is the principal object*, such cows should always be chosen as are known to afford the best milk and cream, and in the largest quantity, of whatever breed they may be. But the weight of butter to be made from a given number of cows must always depend on a variety of contingent circumstances : such as the size and goodness of the beasts ; the kind and quantity of the food ; and the distance of time from calving. As to the first, it need scarcely be mentioned that a large cow will give greater store of milk than one of a smaller size ; though cows of equal size differ as to the quantity of cream produced from the milk of each : it is, therefore, on those cows whose milk is not only in large abundance, but which, from a peculiar inherent richness, yields a thick cream, that the butter dairyman is to place his chief dependence ; and where a cow is deficient in either of these, she should be parted with, and her place supplied by one more proper for this use. As to the second particular, namely, the kind and quality of the food, those who would wish to profit by a dairy ought to provide for their cows hay of a superior goodness, to be given them in the depth of winter, and this in an unlimited degree, that they may always feed till they are perfectly satisfied : and, when the weather will permit, the cows should be indulged with an outlet to marshes or low meadow-grounds, where they may feed on such green vegetables as are present ; which is far preferable to the practice of confining them the whole day on dry meat, will enable them to yield greater plenty of milk, and will give a fine yellow colour to the butter even in the winter season.

6866. *In the vales of Buckinghamshire and Oxfordshire*, very great numbers of cows are kept for the purpose of butter. These fertile lands maintain a breed of large cows, which yield great store of milk ; so that it is no uncommon circumstance for one farmer to keep a herd of fifty or sixty, and to collect a quantity of cream sufficient to fill a barrel-churn of sixty gallons in a week. The butter made from this cream is sold by the farmer or dairyman to persons who make it their business to purchase this article at a stated price from Michaelmas to Lady-day, and at an inferior rate from Lady-day to Michaelmas. The butter thus collected is sent to London every week in waggons. It is consigned to the dealers, who retail it to the consumer ; and no small profit from this traffic accrues to the waggoner and the butter-merchant. This butter is mostly made up in lumps of two pounds each, and for that reason it has obtained the name of lump-butter. Its flavour is peculiarly sweet and agreeable, which is chiefly owing to the goodness of the pasture whereon the cows are fed ; for this intrinsic merit would in vain be sought for in butter made from ordinary pastures, how great soever may be the skill of the dairy-woman. Though the grass should be equally luxuriant, the cows of the same breed, and the cream in like abundance, yet would a decided preference still remain in favour of the vale-fed cows ; for, as a fattening beast on rich land will thrive much quicker than on thin soils, though the herbage be shorter on the former than on the poor ground, so will cows give a larger store of milk, and that of a more nutritious quality, when fed on deep fertile meadows, than if depastured on those of inferior goodness or quality.

6867. *Epping butter* has long been held in the highest estimation ; and great quantities are manufactured in Cambridgeshire and the adjoining counties. The Cambridge butter is sent in small pans ; it has an additional quantity of salt mixed with it, to insure its keeping for ten days or a fortnight ; and is generally perfectly free from any rancid taste. Yorkshire, Lincolnshire, and other neighbouring counties, where the land is rich and fertile, likewise supply large quantities of butter, which is salted and put into tubs for the southern markets.

6868. *Where cheese is the principal object*, the management in respect to the cows must be the same.

6869. *When the object is the suckling of calves*, the farmer should provide himself with a breed of cows suited to the quality of his land. Where the farm abounds with fertile pastures, watered with wholesome streams, and not far distant from the yard, so that the cows may be turned immediately out of the suckling house upon their feed, the benefit will be in every respect superior to what can be expected from an arable farm, or where the green land is in a small proportion to the ploughed ; for, in this latter case, the cows must depend for their sustenance chiefly on artificial fodder ; such as clover, rye-grass, turnips, and other roots and herbage.

6870. *The cow-house* should be of a size adapted to the number of the beasts. Each cow should be driven into the house at suckling-time, and her head confined in a proper manner, having some fodder lying constantly before her, and a space left between every beast. When they become accustomed to this kind of restraint, they will without any trouble come into the places destined for them, when the calves may be suckled with the greatest ease and facility.

6871. *The time cows should become dry before their calving* is not agreed on, some contending that they may be milked almost to the time of their dropping the calf without injury ; while others maintain that it is absolutely necessary that they should be laid dry from one month to two, both for the advantage of themselves and their calves. It is probable that much in this business must depend on the manner in which they are kept ; as when well fed they may be continued in milk till within a week or two of their calving, without suffering any injury from it ; but in the contrary circumstances it may be better to let them run dry for a month, six weeks, or more, according to their condition, in order to their more fully recruiting their strength. It appears not improbable, but that the longer the milking is continued, the more free the cows will be from indurations and other affections of the udder ; which is a circumstance deserving of attention. Where only one or two cows are kept for the supply of a family, it is likewise useful to know, that by good feeding they may be continued in milk without any bad consequences till nearly the time of calving.

6872. *Cows sometimes slip their calves* before they are sufficiently grown. Where this occurs, it is essentially necessary to remove such cows immediately from the cow-yards, or from mixing with the other cattle, for a few days. But where cows are much subject to such accidents, it is the best method to get quit of them as soon as possible, as they will seldom turn out profitable afterwards.

6873. *Cows should be kept constantly in good condition* ; as where they are ever suffered to become very lean, and that in the winter season, it is impossible that they can be brought to afford a large quantity of milk, by getting them into perfect condition in the summer months. Where cows are lean at the period of calving, no management afterwards is ever capable of bringing them to afford for that season any thing near the proportion of milk that they would have done if they had been supported in proper condition during the winter. Food of the most nourishing and succulent kinds should therefore be regularly given in suitable proportions in the cold inclement months, and the animals should be kept warm, and well supplied with pure water. Some advise their being cleaned by combing and other means ; but this is a practice which, though useful in making them yield their milk more freely, can perhaps seldom be advantageously employed on an extensive scale.

6874. *Where the herd of cows is extensive*, an account should always be kept of the time when each cow takes the bull, that she may be dried off at a reasonable distance of time before the expected term of gestation be completed. The usual time when the cow is dried off is two months before her calving, when she ought to be suffered to lie quiet, and should not be brought up with the other cows at milking or suckling-time. According to some, if a cow be continued in milk nearer to the time of calving than the period above allotted, it will not only greatly injure her future progeny by rendering it weakly and stunted, but will also have an ill effect on her own health : while others, as we have seen (6871.), consider ten days or a fortnight as sufficient. When a cow is four months gone with calf, the fact may easily be ascertained by pressing upon her off-flank, when the calf will be felt to kick against the hand.

6875. *Cows may be known to be near the time of calving*, by springing at the udder or at the bearing. By springing at the udder is meant the collection of liquid in the bag, which, a few weeks before the time

of gestation is accomplished, assumes, in some degree, the appearance of milk, and may be drawn from the teats. To spring at the bearing, is when this part is more than ordinarily large and distended. Heifers are said to spring soonest at bearing, and old cows at the udder. Some cows are peculiarly given to abortions; and where this happens, they should never be continued long in the herd, as being unlikely to yield any considerable degree of profit to their owners.

6876. *Cows which are expected shortly to calve* ought to be lodged at night in a large convenient out-house, or some other place, for a week or two previously to calving, as it may be the means of saving the life of the calf, and perhaps that of its dam: for, when a calf drops in the yard or field under such circumstances, the hazard of its perishing through the inclemency of the weather is very great, and it may considerably endanger the life of the cow. But if, from inattention or other causes, the creature should catch cold by calving abroad in sharp winter nights (which may be perceived by a refusal of her food, and by her trembling joints), she ought immediately to be driven into a warm shed, together with her calf, and fed with sugar-sops and ale, and with the best and sweetest hay, and should not be suffered to drink any cold water. By this treatment she will mostly recover in a few days; but should the disorder hang about her, balls composed of aromatic cordial substances may be given.

6877. *A milch cow is in her prime at five years old*, and will generally continue in a good milking state till ten years old or upwards; but this depends greatly on the constitution of the animal, some cows, like other animals, exhibiting marks of old age much earlier than others.

6878. *Cows of large size* yield great store of milk when turned on pastures where the grass is in sufficient abundance, or fed with a constant supply of such food as, from its succulency, conduces much towards the nutriment of the creature, and enables her to give large quantities of milk, such as turnips, grains, garden vegetables, &c. But as these large cows require a more ample provision than would fall to their share on the generality of farms, it would seem that they should not be kept by those farmers whose land is not of the most fertile kind; for, on ordinary keep, a small cow will yield a fairer profit than one of the Yorkshire or Staffordshire breed, which, having been bred on the best kind of land, would be starved where a Scotch or a Welsh cow would find an ample supply of food.

6879. *Those who would make the utmost advantage from cows*, either as calf-sucklers, dairymen, or milk-sellers, should always provide a bull to run in the herd, to obviate the perpetual trouble of driving them perhaps a mile or more to the bull, and in order to prevent the loss and inconvenience of their becoming frequently barren. One bull will generally be sufficient for twenty cows. These animals are in their prime at two years old, and should never be suffered to continue longer in a state of virility than to the fifth year; as, after that time, bulls which before were gentle and lay quiet in the cow pastures, are mostly apt to contract vicious dispositions, and become very unmanageable. Whenever this happens, they should be immediately castrated. In the principal town dairies of Scotland, such as Edinburgh, Glasgow, &c. the cows are never allowed to take the bull, but are sold off, after being kept a year or less, to the butcher, and fresh cows bought in their place. This is one very remarkable difference between the management here and in the town dairies of England.

6880. *For feeding of stalled cows*, the following directions are given to the cow-feeder in an improved dairy establishment near Farnham, in Surrey:—"Go to the cow stall at six o'clock in the morning, winter and summer; give each cow half a bushel of the field beet, carrots, turnips, or potatoes cut; at seven o'clock, the hour the dairy-maid comes to milk them, give each some hay, and let them feed till they are all milked. If any cow refuses hay, give her something she will eat, such as grains, carrots, &c. during the time she is milking, as it is absolutely necessary the cow should feed whilst milking. As soon as the woman has finished milking in the morning, turn the cows into the airing ground, and let there be plenty of fresh water in the troughs; at nine o'clock give each cow three gallons of a mixture composed of eight gallons of grains and four gallons of bran or pollard; when they have eaten that, put some hay into the cribs; at twelve o'clock give each three gallons of the mixture as before; if any cow looks for more, give her another gallon; on the contrary, if she will not eat what you give her, take it out of the manger, never at one time letting a cow have more than she will eat up clean. Mind and keep your mangers clean, that they do not get sour. At two o'clock give each cow half a bushel of carrots, field beet, or turnips; look the turnips, &c. over well before you give them to the cows, as one rotten turnip, &c. will give a bad taste to the milk, and most likely spoil a whole dairy of butter. At four o'clock put the cows into the stall to be milked; feed them on hay, as you did at milking time in the morning, ever keeping in mind that the cow whilst milking must feed on something. At six o'clock give each cow three gallons of the mixture as before. Rack them up at eight o'clock. Twice in a week put into each cow's feed, at noon, a quart of malt dust."

6881. *Directions to the dairy-maid*:—"Go to the cow stall at seven o'clock; take with you cold water and a sponge, and wash each cow's udder clean before milking; douse the udder well with cold water, winter and summer, as it braces, and repels heat. Keep your hands and arms clean. Milk each cow as dry as you can, morning and evening; and when you have milked each cow, as you suppose, dry, begin again with the cow you first milked, and drip them each; for the principal reason of cows failing in their milk is from negligence in not milking each cow dry, particularly at the time the calf is taken from the cow. Suffer no one to milk a cow but yourself, and have no gossiping in the stall. Every Saturday night give in an exact account of the quantity of milk each cow has given in the week." (*Farm. Mag.* vol. xv. p. 314.)

6882. *Harley's dairy establishment at Glasgow* has been celebrated since 1813. The object of the proprietor, who is engaged in various extensive concerns, is to supply the public with new milk free from adulteration, and to have the cow-house, cows, and milk kept in a more cleanly state than by the usual mode.

6883. *Harley's cow-house* is fitted up upon a new construction. The cattle stand in rows, twelve in a row, across the house, head and head, and tail and tail, alternately; there is a passage behind for cleaning, and one in front for feeding. In front of each cow is a wire grating, hung like a window sash, which lifts up when giving the soft food and cleaning the cribs, and is put down when they get hay, &c. The contrivances for washing the cribs, collecting the urine, ventilating the house, &c., give peculiar advantages to the establishment, which may be summed up in the following items:—The health of the cattle; the preservation of the timbers; the diminished danger from fire, there being no hay-loft above the cattle; the preservation of the provender; and the flavour of the milk. The heat is regulated by thermometers. A circulation of air can be produced, so as to keep the cattle comfortable in the hottest weather, by which their health is promoted. The ventilation also prevents the timber from rotting; makes the cows eat their fodder better, as their breath is allowed to escape, instead of being thrown back upon the food, as is the case when their heads are placed opposite a wall. It is well known that milk easily takes a taste from any other substance; of course, if the cow-house is filled with bad air, the milk, while passing from the teat to the pail, and during the time it may stand in the house, will be impregnated with the foul atmosphere.

6884. *In feeding, and preparing the food*, Harley has made many experiments: and by the mode he now follows, the cattle fatten and milk better, than by the ordinary process; and the milk has no taste from turnips or other vegetables.

6885. *The arrangement for milking*, insures the cow to be clean milked, and also prevents fraud; and the mode of lock-

ing up the milk, and at the same time of admitting air, prevents adulteration by the retailer. The cows are not farmed out to milkmen as in London.

6886. *The stock of cows* for some time back has been 120, averaging eleven English quarts each per day; but both quality and quantity depend much upon the kind of food. Harley gives a decided preference to the Ayrshire breed of cows. They are bought chiefly at country fairs, either newly calved, or a few weeks before calving, and never turned out till they go to the butcher.

6887. *The food of the cows during summer* consists of cut grass and green barley mixed with old hay; and during winter Harley uses a good many turnips and potatoes, all of which are steamed and mixed with cut hay and straw; also grains and distillery wash, when these can be got.

6888. *When there is more new milk than supplies the demand*, part is put in the milk-house till next day, when the skimmed milk is sold at half price, and the cream sold at 1s. 6d. per quart. When any cream is left, it is put in a churn, and made into butter once a week or fortnight.

6889. *A table of regulations* has been adopted for the times of feeding, milking, currying the cattle, cleaning the house, &c. Each person has a currycomb and a hair cloth for cleaning the cows twice a day, and a mop and pail for the house, which is washed and sanded twice a day.

6890. *The cleanly state of the cattle and house* makes it a treat for visitors to see the establishment; and the way the vessels and milk-house are kept has made some people fond of milk who formerly were disgusted at it, from the manner in which many town dairies are conducted.

6891. *The advantage of irrigating grass lands with the cow's urine* almost exceeds belief. Last season some small fields of old grass were cut six times, averaging fifteen inches in length at each cutting, and the sward very thick. The soap-suds of a public washing-house are applied to the same purpose with considerable advantage.

6892. *The advantage of this system* to the owner of the cattle is shown by the following abstract, in Harley's own words; but the benefit of a liberal supply of genuine milk to the community at large, particularly to children, it is not easy to estimate:—

To the general health of the cattle by ventilation	} 15 per cent.
To the prevention of a disease called grain sickness, when fed on grains	
To the prevention of swelling, by eating young and wet grass	
To the prevention of choking, when feeding on turnips or potatoes, &c.	
To saving in the expense of feeding, by improved modes of cooking, &c.	15 do.
To saving of labour in feeding, dunging, &c.	20 do.
50 per cent, as one person will do as much as two on the old plan; but allow 25 of this for draining, &c., leaves 25 per cent. profit on servants' wages	25 do.

6896. *The London dairies* of most eminence are the two at Islington, belonging to Mr. Laycock and Mr. Rhodes, and the Metropolitan Dairy in the Edgeware Road. From 1822 to 1829, a number of other dairies sprang up, and made a conspicuous figure for a time; but, like other bubbles of those years, they have nearly all burst, and none now remain worth notice. We examined the Islington and Metropolitan dairies in October 1830, and the following is a brief outline of the result:—

6897. *Rhodes's Islington dairy* is the most complete of the three establishments. It has been in existence for upwards of thirty years, having been commenced by the father of the present possessors, and carried on for a considerable time in the neighbourhood of Greenwich. The number of cows kept by the present Messrs. Rhodes exceeds, on an average of the year, four hundred: at one time these individuals are said to have had upwards of a thousand cows in their different establishments. The surface on which the buildings are placed is a slope of two or three acres, facing the east; and its inclination is about one inch in six feet. The sheds run in the direction of the slope; as well for the natural drainage of the gutters, and the more easily scraping, sweeping, and wheeling out of the manure, as for supplying water for drinking to small cast-iron troughs, which are fixed in the walls, at the heads of the cattle, in such a manner as that the one trough may be supplied from the other throughout the whole length of the shed. The sheds are twenty-four feet wide; the side walls about eight feet high; the roof of tiles, with rising shutters for ventilation, and with panes of glass, glazed into cast-iron skeleton tiles, for light. The floor is nearly flat, with a gutter along the centre; and a row of stalls, each seven feet and a half wide, and adapted for two cows, runs along the sides. The cows are fastened by chains and rings, which rings run on upright iron rods, in the corners of the stalls; the common mode being departed from only in having iron rods instead of wooden posts. A trough or manger, formed of stone, slate, or cement, of the ordinary size of those used for horses, and with its upper surface about eighteen inches from the ground, is fixed at the head of each stall. Four sheds are placed parallel and close to each other, and in the party walls are openings, about a foot in breadth and four feet high, opposite each cow. The bottom of these openings is about nine inches higher than the upper surface of the troughs, and is formed by the upper surface of the one-foot-square cast-iron cisterns, which contain the water for drinking. Each cistern serves two cows, which of course are in different sheds, but adjoining and opposite each other. All these troughs are supplied from one large cistern by pipes, in a manner which can be so readily conceived, that we shall not stop to offer a description. Each of these troughs has a wooden cover, which is put on during the time the cows are eating their grains, to prevent their drinking at the same time and dropping grains in the water. At the upper end, and at one corner of this quadruple range of sheds, is the dairy, which consists of three rooms about twelve feet square: the outer, or measuring room; the middle, or scalding room, with a fire-place and a boiler; and the inner, or milk and batter room, separated by a passage from the last. At the lower end of the range is a square yard, surrounded by sheds; one for fattening the cows when they have ceased to give milk, and the others for store and breeding pigs. The pigs are kept for the purpose of consuming the casual stock of skim milk which occasionally remains on hand, owing to the fluctuations in the demand. This milk is kept in a well, walled with brick laid in cement, about six feet in diameter, and twelve feet deep. The milk becomes sour there in a very short time; and, as it is well known, is found most nourishing to the pigs when given in that state. Breeding swine are found most profitable; the sucking pigs being sold for roasting. Beyond this yard is a deep and wide pit or pond, into which the dung is emptied from a platform of boards projecting into it. The only remaining building wanted to complete the dairy establishment is a house or pit for containing the exhausted malt (grains), on which the cows are chiefly fed. Messrs. Rhodes have a building or pit of this description at some distance, where they have a smaller establishment. There are a stack-yard, sheds, and pits for roots, straw, and hay, a place for cutting hay into chaff, cartsheds, stables, a counting-house, and other buildings and places common to all such establishments, which it is not necessary to describe.

6898. *The cows in Rhodes's dairy* are purchased newly calved in the cow market held in Islington every Monday. They are kept as long as they continue to give not less than two gallons of milk a day, and are then fattened on oil-cake, grains, and cut clover hay, for the butcher. The short-horned breed is preferred, partly for the usual reason of being more abundant milkers than the long horns, partly because the shortness of their horns allows them to be placed closer together, and partly because this breed is more frequently brought to market than any other. The Ayshire breed has been tried to the number of 150 at a time, and highly approved of, as affording a very rich cream, as fattening in a very short time when they have left off giving milk, and as producing a beef which sold much higher than that of the short horns. The difficulty,

To saving of timber in the building, as they will last more than double the time 50 per cent.
6893. *Harley has a steam-engine* for driving the following machinery:—

- A small threshing-mill.
- A straw-cutter.
- A turnip and potato slicer.
- The churning apparatus.
- Pumping water, &c.
- The same boiler that drives the engine steams the food, warms water, &c.

6894. *After much study, labour, and expense*, the establishment is now brought to such a state of perfection, that it receives the cordial approbation of all who have seen it; furnishing the community with genuine milk at a comparatively low price. It is admitted, that the greater part of the system is original, and is not to be met with in any part of the kingdom. (*Farm. Mag.* xv. 189.)

6895. *The merits of Harley's system* are now considered to be greatly exaggerated in the above account. Taking the system altogether, it may be described as essentially that employed by the dairy-farmers in Holland and the Netherlands, described at length by Radcliff and Sinclair, and noticed in preceding sections of the present work from the above and other writers.

however, in procuring this breed was found so great, that Mr. Rhodes was obliged to leave it off. The length of time during which a cow, treated as in this establishment, continues to give milk, varies from six months to the almost incredible period of two years. We were assured of there being at this moment several cows among the 390 which we saw, that had stood in their places even more than two years, and continued to give upwards of one gallon of milk daily.

6899. *The treatment of the cows in Rhodes's dairy* differs from that in most other establishments. The cows are never untied during the whole period that they remain in the house. In most other establishments, if not in all, stall-fed cows or cattle are let out at least once a day to drink; but these animals have clear water continually before them. They are kept very clean, and the sheds are so remarkably well ventilated, by means of the openings in the roofs, that the air seemed to us purer than that of any cowhouse we had ever before examined; probably from its direct perpendicular entrance through the roof, this, in moderate weather, being certainly far preferable to its horizontal entrance through the side walls.

6900. *The principal food of the cows in Rhodes's dairy*, as in all the other London establishments, consists of grains; that is, malt after it has been used by the brewer or the distiller. As the brewing seasons are chiefly autumn and spring, a stock of grains is laid in at these seasons sufficient for the rest of the year. The grains are generally laid in pits bottomed and lined with brickwork set in cement, from ten to twenty feet deep, about twelve or sixteen feet wide, and of any convenient length. The grains are firmly trodden down by men, the heaps being finished like hay-ricks, or ridges in which potatoes are laid up for the winter, and covered with from six to nine inches of moist earth or mud, to keep out the rain and frost in winter, and the heat in summer. As a cow consumes about a bushel of grains a day, it is easy to calculate the quantity required to be laid in. The grains are warm, smoking, and in a state of fermentation when put in, and they continue fit for use for several years; becoming somewhat sour, but they are, it is said, as much relished by the cows as when fresh. It is common to keep grains two or three years; but in this establishment they have been kept nine years, and found perfectly good. The exclusion of the air almost prevents the increase of the fermentation and consequent decomposition. What is called distiller's wash, which is the remainder after distillation of a decoction of ground malt and meal, is also given to cows, but more frequently to such as are fattening than to those in milk. The present price of brewers' grains is four-pence half-penny per bushel; of distillers' grains, on account of the meal which they contain, nine-pence a bushel; of wash, thirty-six gallons for sixpence.

6901. *Salt* is given to the cows in Rhodes's dairy at the rate of two ounces each cow a day. It is mixed with the grains which are supplied before milking, about three o'clock in the morning; and in the afternoon, about two o'clock, just before milking.

6902. *Of green food or roots* portions are supplied alternately with the grains; and in winter, when tares or green grass cannot be procured, after the turnips, potatoes, or mangold wurzel have been eaten, a portion of dry hay is given.

6903. *The produce of this dairy* is almost entirely milk and cream for private families and for public hospitals and other institutions. A number of the public establishments are supplied directly from the dairy, by contract; but private families are principally supplied by milk-dealers: these have what are called milk-walks; that is, a certain number of customers whom they call upon with supplies twice a day; and they are thus enabled to ascertain the average of what their customers consume, and to contract with Messrs. Rhodes for this average. The latter calculate the number of cows sufficient to give the dealer the supply wanted, and this number the dealer undertakes to milk twice a day, to wit, at three o'clock in the morning and at three o'clock in the afternoon. The milk is measured to the dealer, and should he have milked more than his quantity it remains with the dairy-man; but should the cows have been deficient in the quantity, it is made good from the milk of other cows milked on account of the contracts of the establishment. As the supply of the cows and the demand of the dealers are continually varying, it often happens that considerable quantities of milk remain on the dairy-man's hands, frequently, we are told, as much as sixty or seventy gallons a day. This quantity is placed in shallow earthen vessels, to throw up the cream in the usual manner; this cream is churned, and the butter sold, and the skim-milk as well as the butter-milk is put in the cesspool for the pigs.

6904. *The management of Rhodes's dairy* is committed to three persons:—A clerk, who keeps the books, collects debts, pays and receives; a man, who superintends the feeding and the treatment of the stock, and has the general care of the premises; and a dairy-woman, who sees the milk measured to the dealers, and superintends the dairy. The cows are purchased and sold by regular salesmen.

6905. *Laycock's dairy establishment* is also situated at Islington, and covers a number of acres. The cows vary in amount from 400 to 700; but there are open sheds sufficient to shelter from 8000 to 9000 head of cattle, and these sheds are accordingly appropriated to taking in cattle for the nights previous to the days on which Smithfield market is held. We shall only notice those particulars in which this establishment differs from that of Messrs. Rhodes. The cows are fed in the same manner, with the exception of not receiving any salt among their grains; but the hay is salted when put into the rick. They are turned out once a day to drink from troughs in the yards, remaining out from half an hour to three hours, according to the weather and the season of the year. From the end of June till Michaelmas, the cows are turned into the fields from six o'clock in the morning till eleven o'clock, and from two o'clock in the afternoon till about three o'clock in the following morning. The remaining hours of the twenty-four they are in the cow-houses for the purpose of being milked. The cows are kept in use much longer than at Messrs. Rhodes's establishment. Those which become barren are fattened in the same manner on grains, oil-cake, and, what is rather uncommon, boiled linseed. This linseed is boiled in a common boiler, and when reduced to a pulp, let out by tubes into large wooden cisterns, where it is mixed with clover-chaff, roughly cut, and sometimes with grains, and afterwards given to the cattle. Those cows which are good milkers are allowed to take the bull, for which purpose eight bulls are kept. The usual period of keeping the cows is three or four years; the calves are sold in Smithfield, when only a few days old, to those whose business it is to take them to the country and feed them for the butcher. Mr. Laycock has an extensive farm at Holloway, another at Enfield, and one at Clapton; at one or other of these farms the cows in calf are kept when dry. The hair of the tails is kept short to avoid the risk of dirtying the milk, and their bodies are sometimes curry-combed. The fattening cows stand with their hind feet on planks, laid as part of the pavement, the latter consisting of rather small sharp stones. The pigs, in addition to milk kept till it becomes sour, are fattened with ground linseed and grains. The manure made by the cattle and pigs is very considerable, and is all used on Mr. Laycock's own farms. The establishment here, as well as a dairy and cattle repository, may be considered as a central farm-yard to three hay-farms, and there are, accordingly, implements of various kinds, stables, a carpenter's shop, smith's shop, wheel-wright, &c. &c. Mr. Laycock himself seems to take the entire management, assisted by a clerk and a very active house-keeper, with a dairy-woman.

6906. *The Metropolitan Dairy establishment* is situated in the Edgware Road; it was founded by the late Mr. Rhodes fifteen years ago, and after undergoing various changes, and among others being possessed by one of the bubble companies, from

which its present name is derived, is now the property of Mr. Wilberforce. It stands on less than an acre of ground, and is well arranged. It is calculated for 360 cows, and it now contains 320, most of which are in milk, but some are fattening. The cowhouses are in parallel ranges twenty-four feet wide, the side walls eight feet high, the space allowed for each cow about three feet nine inches, and the greater number of cowhouses without stalls. There is one gutter in the centre, and no raised foot-path there; it being found that the latter is very apt to make the cows stumble, when turned out upon any occasion. It is true, these occasions are rare, for the cows here, as in Messrs. Rhodes's establishment, are never untied from the day they are put into the milking shed till they are removed to the fattening sheds, or till they are taken out to be sold, or to be sent into the country to remain till calving time. A cow so treated seldom produces more than two calves, remaining after each calf, at an average, eighteen months in milk. There is one cow here, however, which has given milk upwards of three years since she calved, still producing a gallon and a half a day. The cows are milked at three o'clock in the morning, and two o'clock in the afternoon, and the milk disposed of to dealers. The food consists of grains, which, instead of being kept in pits in the open air, are preserved in the cellar, or lower part of a building, about fourteen feet deep, the upper floor serving as a hay-loft, or chaff-cutting room. To protect the grains from the influence of the air, they are covered to the depth of a foot with cow-dung. Grass and roots constitute the rest of their food; dry hay being seldom given, and the chaff of clover hay being always mixed with grains or wash. The cows are never turned out to water; but from a large cistern pipes are conducted to every cow-house, and at a certain hour every day (one o'clock) the water is turned into the manger, which is on a perfect level, and it runs slowly past each cow, who drinks at pleasure. When any cow becomes sick, she is bled, and purged by giving her one pound of Epsom salts, with two ounces of flower of sulphur, and abundance of warm water. This mode of treatment seldom or never fails. Four bulls are kept for the cows; and as there is no farm belonging to the establishment, when a cow in calf becomes dry or nearly so, she is sent to any grass farm in the country, till near her calving time. To render a cow dry, it is only necessary to give two or three extra-doses of salt in her food. The quantity of salt given here daily with the grains is not much more than an ounce a day, on account of its drying quality. Manure has been sent from this establishment to Yorkshire; but this is found not to pay; and of so little value is it considered as manure, that as much as possible of the fluid part is discharged by the common sewer; and the present proprietor contemplates to compress the more consistent material into small squares like peats for fuel. By a hydraulic press we have no doubt that a two-horse cart load of any common cow-dung might be reduced to the size of a cubic foot. The cows in this establishment, as in the two others, are very sparingly littered; what is given is chiefly laid about their fore legs, and in consequence the other parts of the cowhouse, for want of under-ground gutters, as in Holland and Germany, are always watery and dirty.

6907. *The defects of the London dairy establishments* appear to us to be chiefly want of cleanliness, and imperfect ventilation. The first isto be removed by under-ground gutters, covered with oak plank pierced with numerous holes; and by the more abundant supply of litter: the second by openings in the roof as at Messrs. Rhodes's establishment, which, as we have said before, seems the most perfect in that respect of the three just examined. Compared with the Dutch and German dairies (p. 525. 587. and 611.), and with that of Harley of Glasgow (p. 6882.), they are very deficient both in original design and in management. It is a great mistake to suppose that they are lucrative concerns; and the idea is by no means pleasing of consuming milk chiefly manufactured from grains and distiller's wash, and produced by cows deprived of all exercise in the open air. Not more agreeable is the knowledge of the fact that the London market is supplied with so large a proportion of cattle fattened chiefly on oil-cake. According to a calculation we formed, the three establishments mentioned must supply, at an average of the year, nearly thirty fat cattle weekly. Booth's establishment, already described (6861.), probably furnishes half that number at the average of the year; and taking into consideration other establishments for fattening on oil-cake and grains, local and provincial, we shall probably not be far wrong in estimating that this description of beef is at all times the prevalent one in the London market. The cattle fed in pairs in hammels, (§ 2831.) that is, permitted to walk about in an open shed, as in Berwickshire and East Lothian, must produce a very different description of beef. The time will no doubt arrive when oil-cake beef will not find a market in England, but when the cattle so fed will be sent alive in steam boats to the Continent, or other parts of the world, where the taste of the inhabitants in the article of butcher's meat is less refined. Already country dairies have sprung up at the distance of from five to twenty miles from London, and the milk and cream are sent to town in close vessels in spring carts, which go at a rapid trot. When, instead of these spring carts, rail-roads are established, on which carriages may go at the rate of thirty miles an hour, the milk and butter used by the commonest people of London will be of as good a quality as that now used almost exclusively by gentlemen who have country seats.

SUBJECT. 8. *Working of Horned Cattle.*

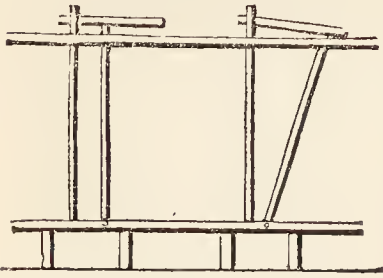
6908. *The arguments for and against the working of oxen* have been already stated. (4828.) Though horned cattle are gradually disappearing as beasts of labour, it is probable they will in many places be occasionally used as a substitute for horses, or to get up one or two additional teams on extraordinary occasions. Indeed we see no objection to the occasional use of both oxen and cows for this purpose; more especially in cases likely to occur in the farming of an extensive proprietor, such as breaking up his park, or cutting down and carting away timber, earth, gravel, &c. to a greater extent than can be readily performed by the ordinary teams of the establishment. For these and similar purposes of amateur farmers, and probably for some purposes on the farms of rent-paying cultivators, the horned cattle of the farm may afford a valuable resource. For these reasons, it seems fitting in this work not to consider the working of oxen as altogether an obsolete practice; and we shall, therefore, notice the training, harnessing, shoeing, age of being put to work, and general treatment of these animals so employed.

6909. *The training of the calf* intended for labour, according to some, should commence at an early period; and after being accustomed to be handled, he should be taught to present his foot to the shoeing smith, as readily as the horse, which is partially the practice in some places. No animal, however, is so easily broke as the ox at any age; and in most countries, where they are used in labour, they are never handled till harnessed and put in the plough, or to drag a tree. This is the case both in Devonshire and

Herefordshire, and as they are only worked a few years it does not seem desirable to be at any great expense in their training. The Roman practice, in this particular, may deserve imitation. (99.)

6910. *Working oxen when kept in a house* are generally confined to their places by the same sort of fastening used for cows, (fig. 865.), in which their neck has free play between two upright spars; but in

865

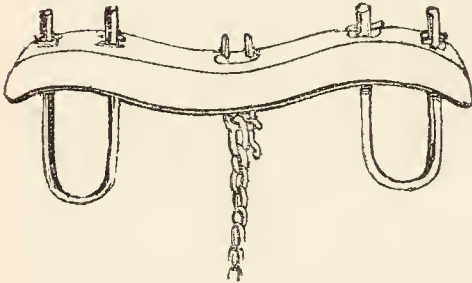


some establishments a ring of a particular description (fig. 866.) is used, to which they are tied by a halter attached to a head strap or bridle. The ring is generally screwed into the front of the manger or eating trough. The cattle fastening used in Devonshire is a wooden bow put on their necks and fastened to a round post. The bow consists of two pieces; the yoke, which has two slits terminating in round holes; and the bow, which is made of split ash, and has a knob at each end. These knobs being put through the round holes, the elasticity of the bow forces it along the slit and prevents it from returning.

6911. *Harness for labouring cattle* is of three kinds: that for bearing as saddles some sorts of oxen yokes; that for drawing or pushing, as traces, brechins of saddles, &c.; and that for guiding the animals, as bridles, halters, reins, &c. These articles are of considerable expense, but when taken care of, kept dry, and the iron joints and leathers oiled occasionally, they will last a long time. In making all harness for beasts of labour great care ought to be taken to avoid superfluous materials which only encumber, and ornaments which only add to the expense. The London harness is much too heavy for agricultural purposes; that of Berwick or Newcastle is much more light and sufficiently strong.

6912. *The most approved kind of harness* for the ox is little different from that of the horse, except in the shape of the collar. In many places however, and especially on the Continent, the ox draws solely by the withers, by means of what is called a yoke and bow. (fig. 867.)

867



6913. *The shoeing of oxen* is a practice which is yet far from being performed in a perfect manner. Clark says, that in many parts of France, where the ox is used for draught, it is sometimes necessary to employ eight shoes, one under each nail; or four, one under each external nail; and sometimes only two, one under the external nail of each fore foot. In this country two pieces or shoes to each foot are generally made use of, being mostly fixed on, especially in the northern districts, with three or four large-headed nails to each shoe. They are fitted on in a similar manner to those of the horse. But, as the shoes of these animals from the smallness of the pieces are so liable to

break, it has been suggested to have them shod with whole shoes in the manner of the horse; but how far this practice would answer, must depend upon future trials. As there is much trouble in the shoeing

869



of oxen, from the necessity for casting them each time, it has been found requisite to have recourse to contrivances for shoeing them standing (fig. 868.)

6914. *An ox shoe* (fig. 869.) consists of a flat piece of iron, with five or six stamp holes on the outward edge to receive the nails; at the toe is a projection of some inches, which, passing in the cleft of the foot, is bent over the hoof, so as to keep the shoe in its proper place. This projection is not, however, employed in the general practice of making these shoes.

6915. *The age at which an ox may be worked* is from two and a half to three and a half years. Some begin at two, but it ought to be for very light operations, and such as are not of long duration. The period to which the ox is worked varies from his fifth to his tenth year.

6916. *Parkinson's father* used to make up occasionally an ox team for the plough of four oxen and one horse as a leader, which he found did about two thirds of the labour of two horses. There are, he says, great objections to ox-teams in the plough. He has, however found them useful in some sorts of farm-work, from their slow, steady pace; as in scarifying, leading dung, &c., as the work suits them from its being easy, and having a great deal of standing: they are, says he, much more cheaply kept than horses, and eat straw in the winter, and are valuable for making dung. He never saw this practice injure their growth. They may be worked from two till five years old, without any loss of time, as they grow to that age, and are then both larger and better beef than three-year-old steers. He therefore recommends ox-teams for leading dung and the other odd jobs, but not to plough and harrow. If they are worked to the age of eight or ten years, it is, he thinks, a real injury to the public, and an unprofitable practice to the farmer.

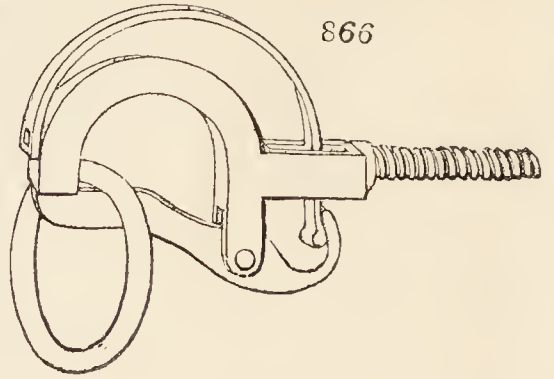
6917. *Bakewell* used to work his heifers moderately, whilst carrying their first calves; an unobjectionable practice, provided they are well fed. Bulls are generally allowed to be good labourers, and capable, if high fed, of vast exertions.

6918. *The length of time per day which an ox is kept in the yoke* varies according to the kind of labour, and the age and keep of the ox. If an ox is fed on hay, oats, and some roots, he will plough four days a week; but if on straw and roots only, not above three days. In the former case he is worked two whole days and two half days, and in the latter case six half days. The latter is the best plan, for which reason, where oxen are regularly worked, two pairs should be kept for each ploughman.

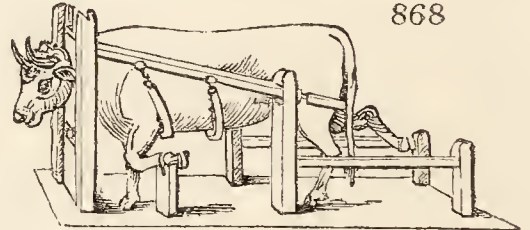
6919. *The most desirable breeds of oxen to work* are the Devonshire and Herefordshire varieties, which are long-legged, quick-stepping animals. Lord Somerville, who has carried the working of oxen to greater perfection than any one else, prefers the Devon breed, which most cultivators consider the quickest walkers in England. When horned cattle are only worked occasionally, whatever sort of animals are on the farm, whether bulls, cows, or oxen, of good or bad breeds, will necessarily be employed.

6920. *The food of horned cattle employed in labour* must be substantial. It is a great mistake to suppose they can work on straw alone. Unless they have roots added to straw in winter, and green food in summer, it will be an idle attempt to harness animals so nourished. The best and indeed the only way is to feed them well with straw, coarse hay, roots, green herbage, or pasturage, as the season and other circumstances may indicate.

866



868



SUBJECT. 9. *Anatomy and Physiology of the Bull and Cow.*

6921. *The general structure of the bull and cow* presents some peculiarities when compared with the horse, whose anatomy having been fully explained, will be taken as the subject of comparison. The ox, as an animal machine, displays less complexity of structure than the horse; but the principal differences between the two will be found to arise from the evident intention of nature to bound the locomotion of horned cattle: the limbs of the ox are therefore not found favourable to speed; nor does his general mass betray that symmetrical proportion and mechanical composition that would fit it to be acted on to advantage, as it regards quick motion, by the powerful muscles he evidently possesses; for strength alone will not produce speed.

6922. *The skeleton of the ox* is formed under the above view; and though the number of his bones differs little from that of the horse, the general form differs materially; — the frontal, the occipital, and indeed most of the bones composing the skull are broad and extended, while to the former are appended the horns. These, as we have seen (1859.), partake of the nature of true bone, placed within a membranous envelopment of a mixed nature between cuticle and cartilage. The ox has no upper nippers; the grass being cropped into a tuft by means of the tongue, is cut off by the under nippers; whereas in the horse it is nipped off by the approximation of both incisive teeth.

6923. *The vertebrae or neck bones* are the same in number and form as in the horse; but from the diminished elevation of the head, and the peculiarity of attachment of the great suspensory ligament, the ox has no cervical crest. The dorsal vertebrae are thirteen, with spinous processes, or withers less high. The lumbar vertebrae are six, and the sacral four; the coccyx or bones of the tail are indefinite in number, from eighteen to twenty-five. The pelvic bones in the ox are very large; and the rugged outline of the rump in cattle arises from the great rising of the spine of the ilium, and tuberosity of the ischium: the ribs are thirteen, eight of them true, and five false; and upon the former rest the scapulae, which do not materially differ from those of the horse.

6924. *The fore-limb bones* are, the arm, and the fore-arm, which, as in the horse, is composed of the radius and ulna, and bears a general resemblance to that of the horse. The knee is composed of four bones in the first row, and two in the second, which renders that joint inferior to that of the horse in complexity and elasticity: the same holds good with regard to the hock, where the bones entering its composition are also less numerous than in the horse. The canon or shank has no splint bones attached to it, but it is lower, and enlarges into two articular portions corresponding with the metacarpal before, and metatarsal bones behind: thus, from the pastern downwards, the limb is double, and ends in two separate hoofs, which present, individually, a similarity of structure and design to the single hoof of the horse, but less developed; to the posterior part of each are appended two imperfect phalanges or claws, thus keeping a connection with the digiti.

6925. *The hinder limbs* present nothing remarkable, but preserve the same increased simplicity of structure with the fore.

6926. *The viscera of the chest* offer no peculiarities from those of the horse to deserve notice; neither is the economy of the organs concerned different.

6927. *The viscera of the belly of the ox* have some specialities, the principal of which consist in the digestive organs, which differ in form, structure, and economy, in some essential particulars, from the same system in the horse.

6928. *The ox has four stomachs*, in which formation the goat, sheep, camel, and deer participate. As it is necessary that these animals should collect much herbage for their support; and as it would fatigue and keep them too long in motion to gather and masticate such a quantity at the same time, so a peculiar provision has been made for them, by which they first hastily collect their food, pass it into a reservoir, and afterwards commence the mastication of it at their leisure.

6929. *The first stomach, rumen, or paunch*, is a very large membranous and muscular bag, principally occupying the left side, and extending, when full, from the middle of the ribs to the haunch, into which the unruminated food is received; consequently, it is the over-distention of this which occasions the malady called hoven: it is in this stomach also that the concretions called hair balls are found. It presents numerous processes to assist in the retention of the food.

6930. *The second stomach*, called also reticulum, bonnet, or kingshood, would appear as a globular appendage to the paunch merely, were it not for its peculiarity of structure, which resembles the cells of the honey-comb, and which is well known to the eaters of tripe. The œsophagus, or gullet, enters at the junction of this with the first stomach, and is continued in the form of a muscular ridge, or segmental tube along the line of junction between these two stomachs, which is thence continued into the *many-plies*. In the hornless ruminants, the second stomach is exclusively designed as a reservoir for water, and is capable of holding and preserving a vast quantity of it. A little of this water is passed up, as wanted, to be mixed with the dry matters chewed during rumination. In the deserts of Arabia, where water is met with only at long distances, this reservoir is peculiarly advantageous to the camel and dromedary; and the Arabian travellers, when famishing for water, save themselves frequently at the expense of their camels, by killing of which, and taking out this stomach, they find a supply.

6931. *The third stomach* is named after its foliated structure *many-plies*; there are about eighty or ninety of these septa or folds, which are covered with cuticle, in common with the two former stomachs, by which some resemblance is kept up between the digestive processes of the horse and ruminants. By the comparative insensibility of these stomachs, they can also bear potent medicines, which would be destructive to the Carnivora. By this curious extension of surface, the ruminated food is applied and re-applied to the sides of the bag, to be acted upon in its early stage of digestion.

6932. *The fourth stomach*, called also the *red bag*, abomasum, falfcus, and ventriculus intestinalis, is about two feet nine inches long in an ox, and resembles the simple digestive stomach of the Mammalia. It is in this stomach that the pulaceous mass of the chyme undergoes a more perfect animalisation by being mixed with the gastric fluid, which appears to be wholly secreted here, and thus it is that this stomach only produces rennet. The red bag, to increase its secreting surface, has likewise about nine longitudinal plicae to each side, with an intervening rugose structure.

6933. *Rumination, or chewing the cud*, is the process whereby the ruminant animals having collected their food, and having passed it into the paunch, with little or no mastication or expense of saliva, begins a new operation. The paunch being full, the animal is stimulated to seek rest and quiet, and he usually lies down. The paunch begins now to exert its extraordinary powers of separating a portion from the contained mass, and to return it into the mouth, where it undergoes a complete mastication and mixing with the saliva. It is then again passed down the throat; but instead of again entering the first stomach, the muscular gutter forms itself into a tube, and carries it at once into the third stomach, where, having to undergo a further change, it is passed into the red bag, or fourth stomach; to undergo a further solution by means of the gastric fluid, preparatory to its being converted into nutriment under the name of chyle.

6934. *The intestines of the ox* have not their divisions into great and small so well marked as in the horse; yet the tract is very extended, to admit of a perfect separation of all the chylous particles. In the intestines of the horse it has been shown (6402.) that much of the digestive as well as the operative process goes on; but the chymous mass is more broken down in the stomachs of a cow than by the united forces of the stomachs and intestines of the horse. Grass, containing less organical moléculæ than grain, requires to be minutely acted on to afford nutriment; and thus the well-fed horse, after having been sufficiently nourished, passes off dung containing much of the original principles of his farinaceous food, and which forms excellent manure; while that of the ox, becoming almost wholly decomposed and nearly feculent, is very inferior for that purpose.

6935. *The liver of the ox* is large, and presents a gall-bladder, which that of the horse does not. This gall bag is furnished by several hepatic ducts leading into the neck of the gall duct. By the existence of a gall bladder the bile is evidently more concentrated; but it is difficult to understand why this should be necessary to the ruminants and not to the horse.

6936. *The pancreas of the ox* is of a lozenge form. The *spleen* is very large, and is placed on the left side of the paunch. The biliary and pancreatic ducts unite together. The principal fold of the *omémentum* is very large, and incloses the four stomachs, and part of the intestines. The *renal capsules* are flat and triangular. The kidneys are *lobulated*.

6937. *The organs of generation* in the cow differ but little from those of the mare and other *Mammalia*. The penis of the bull is more pointed and taper than that of the horse. The *vesiculæ seminales* are wanting, but have a small ligamentous bridge instead. The *prostatæ* are two.

SUBJECT. 10. *Diseases of Horned Cattle.*

6938. *Cattle are subject to some very dangerous diseases*; but as their life is less artificial, and their structure less complex, they are not liable to the variety of ailments which affect the horse. The general pathology of the horse and the ox being little different, the fundamental rules for veterinary practice, and the requisite medicines, when not particularised, will be found in the *Veterinary Pharmacopœia*, already given. (6548.)

6939. *Mild fever*, *pantas* or *pantasia*. Cattle sometimes appear affected with heat, redness of the nostrils and eyelids; they refuse food, are dull, evacuate and stale with difficulty; and the urine is high coloured. These symptoms are often aggravated every other day, giving it the appearance of an intermittent affection. The complaint is often brought on by over-driving in very hot weather, occasionally by pushing their fattening process too fast. If there be no appearance of malignancy, and the heaving be considerable, bleed, and give half an ounce of nitre in a drink night and morning; but unless the weather be cold do not house the animal.

6940. *Inflammatory fever* is called, among farriers, cow-leeches, and graziers, by the various names of black quarter, joint felon, quarter evil, quarter ill, showing of blood, joint murrain, striking-in of the blood, &c. Various causes may bring this on. It is sometimes epidemic, and at others it seems occasioned by a sudden change from low to very full keep. Over-driving has brought it on. No age is exempt from it, but the young oftener have it than the mature. Its inflammatory stage continues but a few days, and shows itself by a dull and heavy countenance, red eye and eyelids: the nostrils are also red, and a slight mucus flows from them. The pulse is peculiarly quick; the animal is sometimes stupid, at others watchful, particularly at first; and in some instances irritable. The appetite is usually entirely lost at the end of the second day, and the dung and urine either stop altogether, or the one is hard, and the other red. About the third day a critical deposit takes place, which terminates the inflammatory action: and it is to the various parts on which this occurs that the disease receives its various names. The deposit is, however, sometimes universal, in the form of a bloody suffusion throughout the whole skin. In others, swellings form on the joints, or on the back or belly; and in fact, no part is exempt from their attack. Sometimes the animal swells generally or partially, and the air being suffused under the skin, crackles to the feel. After any of these appearances have come on, the disease assumes a very malignant type, and is highly contagious.

6941. *Treatment of inflammatory fever*. Before the critical abscesses form, or at the very outset of the disease, bleed liberally, and purge also: give likewise a fever drink. (6579.) If, however, the disease be not attended to in this early stage, carefully abstain from bleeding, or even purging; but instead, throw up clysters of warm water and salt to empty the bowels, and in other respects treat as detailed under malignant epidemic. (6436.) It may be added, that four drachms of muriatic acid in three pints of oak bark decoction, given twice a day, has proved useful. The swellings themselves may be washed with warm vinegar, both before and after they burst. The cowhouse should be fumigated daily.

6942. *Catarrh or influenza* in cattle, also known by the name of *felon*, is only a more mild form of the next disease. Even in this mild form it is sometimes epidemic, or prevalent among numbers; or endemical by being local. Very stormy wet weather, changing frequently, and greatly also in its temperature, are common causes. We have seen it brought on by change of food from good to bad; and from too close pasturage. It first appears by a defluxion from the nose; the nostrils and eyelids are red; the animal heaves, is tucked up in the flanks, and on the third day he loses the cud. There is a distressing and painful cough, and not unfrequently a sore throat also, in which case the beast almost invariably holds down his head. The treatment does not at all differ from that directed under the same disease in horses. (6434.) Bleeding only the first two days, carefully sheltering, but in an open airy place, and littering well up.

6943. *The malignant epidemic influenza* is popularly called the *murrain* or *pest*; and has at various times made terrible havoc among cattle. Ancient history affords ample proof of its long existence; and by the accounts handed down, it does not seem to have varied its types materially. In 1757 it visited Britain, producing extreme fatality among our kine. From 1710 to 1714 it continued to rage on the Continent with unabated fury. (*Lancisi's Disputatio Historica de Bovilla Peste*.) The years 1730 and 1731, and from 1744 to 1746, witnessed its attack, and produced many written descriptions of it, among which stand pre-eminent that of Sauvages, the celebrated professor of medicine at Montpellier. The British visitation of the malady in 1757, elicited an excellent work from the pen of Dr. Layard, a physician of London, which was afterwards translated into several other languages.

6944. *Symptoms of the murrain*. Dr. Layard describes it as commencing by a difficulty of swallowing, and itching of the ears, shaking of the head, with excessive weakness and staggering gait, which occasioned a continued desire to lie down. A sanious fetid discharge invariably appeared from the nostrils, and eyes also. The cough was frequent and urgent. Fever exacerbating, particularly at night, when it usually produced quickened pulse. There was a constant scouring of green fetid dung after the first two days, which tainted every thing around: even the breath, perspiration, and urine were highly fetid. Little tumours or boils were very commonly felt under the skin, and, if about the seventh or ninth day these eruptions become larger, and boils or buboes appeared with a lessened discharge of fæces, they proved critical, and the animal often recovered; but if, on the contrary, the scouring continued, and the breath became cold, and the mouth dark in colour, he informs us, mortality followed. Sauvages describes the murrain as showing itself by trembling, cold shivers, nose excoriated with an acrid discharge from it; purging after the first two days, but previous to which there was often costiveness. Great tenderness about the spine and withers was also a characteristic, with emphysema, or a blowing up of the skin by air discharged underneath it.

6945. *Dissections of those that have died* of this disease, according to Sauvages, have shown marks of great inflammation, and of a great putrid tendency; but the solid parts seldom ran into gangrene. The fluid secretions, however, always were sufficiently dissolved and broken down by putridity. The paunch, he says, was usually filled with undigested matter, and the other stomachs highly inflamed; the gall bladder was also commonly distended, with acrid thick brown bile. Goelich, who likewise dissected these subjects, describes the gall as particularly profuse and intolerably fetid. According to him the whole alimentary canal, from the mouth to the anus, was excoriated; and Lancisi, contrary to Sauvages, found the viscera of the chest and belly, in some cases, sphacelated and gangrenous. Gazola describes the murrain as accompanied with pustulous sores; and so great was the putrid tendency, that even the milk, before it dried up, which it usually did before the fourth day, became fetid.

6946. *The treatment of the murrain.* In the very early stages, all eminent authors recommend bleeding; but which should not only be confined to the very early periods, as to the first two days, but also to such subjects as by their previous health and condition can bear it. The animals should be placed in an open airy place; the litter should be frequently renewed; and the place itself should be fumigated with the preventive fumigation. (6582.) It has been recommended to burn green boughs with pitch as a substitute: even charcoal fires occasionally carried round the place would be useful. Dr. Layard advised the body to be washed with aromatic herbs in water; but vinegar would have been better. In the early stages, saline purgatives, as from ten to twenty ounces of Epsom salts, are to be invariably used. If the scouring have already come on, still, however, purge; but with only half the quantity: an artificial purge will carry off the morbid bile; and if excessive weakness do not come on, the same may be advantageously repeated. Setons are also recommended in the dewlap. When abscesses appear, they may be opened, and their contents discharged, washing the wound with brandy or vinegar, if putrid sloughing takes place. The emphysematous swellings or cracklings may also be opened, and the air discharged. The other essentials of medical treatment, as detailed under malignant epidemic among horses, is here applicable in every particular. When recovery takes place, it is usually a very slow process, and requires care to prevent other diseases supervening. The animals should continue to be housed, and neither exposed to sun or wind for some time, and the feeding should be nutritious.

6947. *The prevention of the murrain,* or the prevention of its spreading, in many respects is even more important than its medical treatment. Where it has already appeared, all the out-buildings, but particularly the ox-lodges or stalls, should be daily fumigated with the preventive fumigation (6582.); and even the whole of the infected districts should have frequent fires of green wood made in the open air, and every such district should be put under a rigorous quarantine. The cattle on every farm should be carefully examined three or four times every day, and the moment one is found to droop, he should be removed to a distance from the others. In very bad weather, while it is prevalent, the healthy cattle should be housed, and particularly well fed; and their pasture should also be changed. The bodies of those who die of the disease should be buried with their skins on, very deep in the earth, and quick-lime should be strewed over them.

6948. *Phrenzy fever,* or inflammation of the brain, called also *sough*, now and then, but by no means frequently, attacks cattle. The symptoms differ but little from those which attack horses. The *treatment* must be exactly similar.

6949. *Inflammation of the lungs* occasionally occurs in cattle, in which also the symptoms, progress, and proper *treatment* are similar to those detailed under that head in horse pathology.

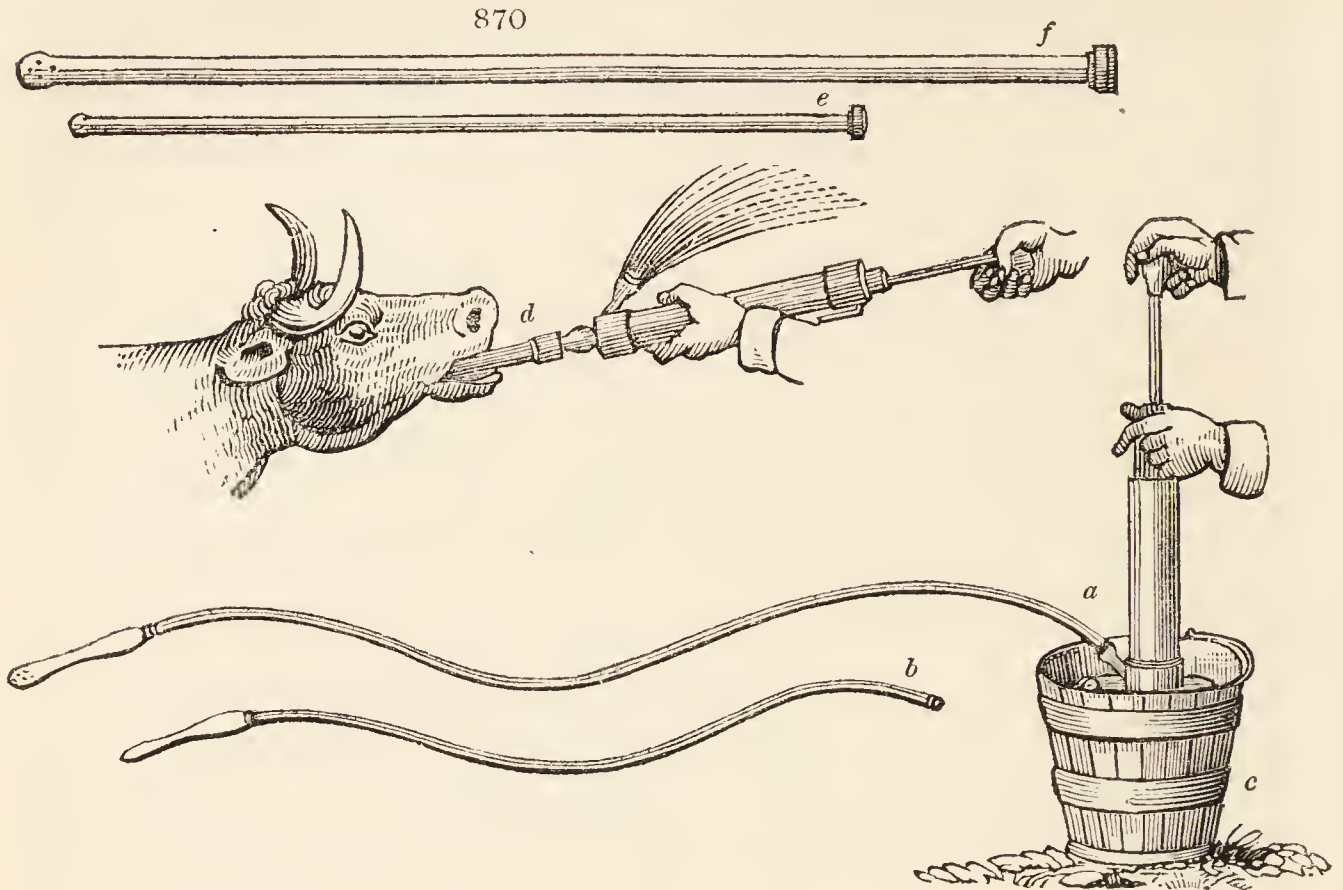
6950. *Inflammation of the stomach* sometimes occurs from poisonous matters; and in such cases, when the nature of the poison is discovered, the *treatment* detailed under poison in horse pathology must be pursued. But there is a species of indigestion to which cattle are liable in the spring, from eating voraciously of the young sprouts of wood; to which some woods are more conducive than others. The symptoms are heat, thirst, costiveness, lessened urine, quick and hard pulse, with heat and redness in the mouth and nose; the belly is hard and painful, and the stools, when they appear, are covered with glair. When the mouth and nose discharge a serous fluid, the animal usually dies.

6951. *Treatment.* Bleed at first, open the bowels by saline purgatives. (6585.) After this give large quantities of nitrated water, and glister also largely.

6952. *The hove or blown* in cattle is also an inflammatory affection of the paunch, ending in paralysis and rupture of its substance. From the frequency of its occurrence, it has become a subject of investigation with almost every rational grazier, and a particular matter of enquiry with every agricultural body; whence it is now very successfully treated by the usual attendants on cattle, when skilful; but when otherwise, it usually proves fatal. It is observed to be more frequent in warm weather, and when the grass is wet. When either oxen, cows, or sheep meet with any food they are particularly fond of, or of which they have been long deprived, — as potatoes, turnips, the different grasses, particularly red clover, — they eat greedily, and forget to lie down to ruminate, by which means the first stomach, or paunch, becomes so distended as to be incapable of expelling its contents. From this inflammation follows, and fermentation begins to take place: a large quantity of air is let loose, which still adds to the distention, till the stomach either bursts, or, by its pressure on the diaphragm, the animal is suffocated. The situation of the beast is known by the uneasiness and general swelling of the abdomen; with the circumstances of the animal being found with such food, or the presumption that it has met with it.

6953. *Treatment.* There are three modes of relieving the complaint, which may be adverted to according to the degree of distention, and length of time it has existed. These are internal medicines; the introduction of a *probang* of some kind into the paunch by the throat; and the puncturing it by the sides. Dr. Whyatt, of Edinburgh, is said to have cured eighteen out of twenty hoven cows, by giving a pint of gin to each. Oil, by condensing the air, has been successfully tried. Any other substance, also, that has a strong power of absorbing air may be advantageously given. Common salt and water, made strongly saline, is a usual country remedy. New milk, with a proportion of tar equal to one sixth of the milk, is highly spoken of. A strong solution of prepared ammonia in water often brings off a great quantity of air, and relieves the animal. Any of these internal remedies may be made use of when the hoven has recently taken place, and is not in a violent degree. But when otherwise, the introduction of an instrument is proper, and is now very generally resorted to. The one principally in use is a species of *probang*, invented by Dr. Monro, of Edinburgh. Another, consisting of a cane of six feet in length, and of considerable diameter, having a bulbous knob of wood, has been invented by Eager, which is a more simple machine, but hardly so efficacious. It is probable that, in cases of emergency, even the larger end of a common cart-whip, dexterously used, might answer the end. But by far the best instrument for relieving hoven cattle, as well as for clustering them, is Read's *énema* apparatus, which is alike applicable to horses, cattle, and dogs. It consists of a syringe (*fig. 870. a.*), to which tubes of different kinds are applied, according to the purpose, and the kind of animal to be operated upon. There is a long flexible tube for giving an *énema* to horses and cattle (*a.*), and a smaller one for dogs. (*b.*) To relieve hoven bullocks effectually, it is necessary not only to free the stomach from an accumulation of gas, but from the fermenting pultaceous mixture which generates it; for this purpose a tube (*f.*) is applied to the extremity of the syringe, and then passed into the animal's stomach through the mouth (*d.*), and being put in action, the offending matter is discharged by a side opening. When the same operation is performed on sheep, a smaller tube (*e.*) is made use of. The characteristic excellency of Read's instrument is, that there is no limit to the quantity of fluid that may be injected or extracted. The same syringe is used for extracting poison from the stomach of man, for smoking insects, extinguishing fires, and syringing fruit trees. (*Encyc. of Gard.* 2d edit. 1419.) The introduction of any of these instruments may be effected by the help of an assistant, who should hold the horn of the animal by one hand, and the dividing cartilage of the nose with the other; while the operator himself, taking the tongue in his left hand, employs his right in skilfully and carefully introducing the instrument; the assistant bringing the head and neck into such an attitude as to make the passage nearly straight, which will greatly facilitate the operation. But when no instruments can be procured, or as cases may occur when indeed it is not advisable to try them, as when the disease has existed a considerable time, or the animal has become outrageous, or the stomach so much distended with air that there is danger of immediate suffocation or bursting; in these instances the puncture of the maw must be instantly performed, which is called *paunching*. This may be done with the greatest ease, midway between the ilium, or haunch-bone, and the last rib of the left side, to which the paunch inclines: a sharp penknife is frequently used; and persons in veterinary practice should always keep a long trochar, which will be found much the most efficacious, and by far the most safe, as it permits the air escaping certainly and quickly, at the same time that it prevents its entrance into the cavity of the

abdomen, which would occasion an equal distention. As soon as the air is perfectly evacuated, and the paunch resumes its office, the trochar may be removed; and, in whatever way it is done, the wound



should be carefully closed with sticking plaster or other adhesive matter. It is necessary to observe, that this operation is so safe, that whenever a medical assistant cannot be obtained, no person should hesitate a moment about doing it himself. After relief has been afforded by means of either the probang or the paunching, a stimulant drink may yet be very properly given, such as half a pint of common gin; or one ounce of spirit of hartshorn in a pint of ale, or two ounces of spirit of turpentine in ale, may any of them be used as an assistant stimulus. When also the cud is again chewed, still some relaxation of the digestive organs may remain; at first, therefore, feed sparingly, and give, for a few mornings, a tonic. (6551. No. 1.)

6954. *Inflammation of the bowels, or red colic*, is by no means unknown in cattle pathology; the symptoms of which do not differ from those common to the horse, and the *treatment* also is in every respect the same. (6466.)

6955. *Inflammation of the liver, or hot yellows*, sometimes occurs, in which case, in addition to the symptoms detailed under hepatitis in the horse (6479.), there is, from the presence of cystic bile in the ox, a more determined yellowness of the eyelids, mouth, and nostrils; the *treatment* must be similar. (6479.)

6956. *Inflammation of the kidneys, called red water* by the cow-leeches, is not uncommon among cattle, and is, perhaps, dependent on the lobulated form of these parts in them. The animal, to the other symptoms of fever, adds stiffness behind, and often straddles, but always shrinks on being pinched across the loins, where frequently increased heat is felt; the urine is sometimes scanty, and now and then increased in quantity, but it is always first red, then purple, and afterwards brown or black, when a fatal termination may be prognosticated. The *treatment* has been fully detailed under nephritis, in the horse pathology (6481.), and it consists in plentiful bleedings, &c., carefully abstaining from the use of diuretics, as advised by ignorant cow-leeches.

6957. *The black water* is only the aggravated and latter stages of the above.

6958. *Inflammation of the bladder* also now and then occurs, and in nowise differs from the cystitis of the horse in consequences and treatment. (6483.)

6959. *The colics of cattle* arise from different causes: they are subject to a *spasmodic colic*, not unlike that of horses, and which is removed by the same means. (6474.) *Costiveness* also brings on a colic in them, called *clue bound*, *fardel bound*, &c. which often ends in the *red colic*, unless early removed; the *treatment* of this we have fully detailed. (6476.) Another colic is accompanied with relaxation of bowels.

6960. *Diarrhœa, scouring, or scouring cow*, is common in cattle, and is brought on by exposure to rain, improper change of food, over-driving, and other violences. It is essentially necessary that the animals be taken under cover, kept warm and dry, and have nutritious food allowed them. The *medical treatment* has been detailed. (6473.)

6961. *Dysentery, or braxy, bloody ray, and slimy flax*, differs from simple scouring, in a greater degree of fever attending it, and in its being an inflammation of a particular kind, and part of the intestines. It is frequently dependent on a vitiated putrid state of the bile, brought on by over-driving in hot weather, low damp pastures in autumn, &c. The discharge is characterised by its bad smell, and by the mucous stringy patches in it, and also by its heat and smoking when voided: all which are very different from the mere discharge of the aliments in a state of solution in diarrhœa, and which differences should be carefully marked, to distinguish the one from the other: *treat* as under dysentery in the horse. (6470.)

6962. *Yellows*. When active fever is not present, and yet cattle are very dull, with great yellowness of eyelids, nostrils, &c., it arises from some biliary obstruction, to which oxen and cows are more liable than horses, from their being furnished with a gall bladder; it is a more common complaint in some of the cold provinces on the Continent, where they are housed and stall-fed all the year round, than it is in England. The *treatment* is the same as detailed for chronic inflammation of the liver in horses, (6480.) adding in every instance to it a change of pasturage, and if convenient, into salt marshes, which will alone often effect a cure.

6963. *Loss of the cud*. This enters the list of most cow-leeches' diseases, but is less a disease than a symptom of some other affection; indeed it is evident that any attack sufficient to destroy the appetite, will generally occasion the loss of the cud. It is possible, however, that an occasional local affection or paralysis of the paunch may occur, particularly when it is distended with unhealthy substances, as acorns, crabs, the tops of some of the woody shrubs, &c. The *treatment*, in such cases, consists in stimulating

the stomach by tonics, as aloes, pepper, and gin mixed: though these, as liquids, may not enter the stomach in common cases, yet in this disease or impaired action of the rumen they will readily enter there.

6964. *Staggers, daisey, or turning*, are sometimes the consequences of over-feeding, particularly when from low keeping cattle are suddenly moved to better pasturage. *Treat* with bleeding and purging.

6965. *Tétanus, or locked jaw*, now and then attacks cattle, in which case it presents the same appearances and requires the same *treatment* as in horses. (6432.)

6966. *Cattle surgery* is in no respect different from that in practice among horses, the wounds are treated in the same manner. Goring with the horns will sometimes penetrate the cavity of the belly, and let out the intestines: the *treatment* of which is the same as in the horse. (6477.) Strains, bruises, &c. are also to be *treated* like those of horses.

6967. *Foul in the foot*. This occasionally comes on of itself, but is more often the effect of accident: cleanse it well, and keep it from dirt: — apply the foot paste. (6587.)

6968. *Wornals, or puckeridge*, are tumours on the backs of cattle, occasioned by a dipterous insect which punctures their skin, and deposits its eggs in each puncture; these tumours are erroneously attributed to the fern owl or goat-sucker (*Caprimulgus europæus L.*). When the eggs are hatched, and the larvæ or maggots are arrived at their full size, they make their way out, and leave a large hole in the hide, to prevent which the destruction of the eggs should be attempted by nipping the tumour, or thrusting in a hot wire.

6969. *Cattle obstetrics* are not very varied; young cows of very full habits have sometimes a superabundant secretion of milk before calving, which produces fever and heat; sometimes, from cold taken; the same will occur after calving also: in either case, give mild dry food, or hay; bathe the udder also with vinegar and water: in some cases, warm fomentations do best. If the fever run high, treat as under fever in horse pathology.

6970. *The process of calving* is usually performed without difficulty; sometimes, however, cross presentations take place, and sometimes a constriction of parts prevents the natural passage of the calf. To act properly on these occasions, great patience is required, and much mildness: many cows have been lost by brutal pulling; we have seen all the men and boys of the farm mustered to pull at a rope affixed about a calf, partly protruded, which, when it was thus brought away, was forced to be killed, and the mother soon died also from the protrusion of parts this brutal force brought with the calf. A steady moderate pull, during the throes of the animal, will assist much; having first directed the attention to the situation of the calf, that the presentation is such as not to obstruct its progress; if it does, the calf must be forced back, and turned or placed aright.

6971. *Whethering, or retention of the after-birth or burden*. — It sometimes happens that this is retained; for which no better remedy has been hitherto discovered than warm clothing and drenching with ale, administered as a forcer.

6972. *The diseases of calves* are principally confined to a species of *convulsions* which now and then attacks them, and which sometimes arises from worms, and at others from cold. When the first cause operates, it is then relieved by giving a mild aloetic purge, or in default of that, a mild dose of oil of turpentine, as half an ounce, night and morning. In the second, wrap up the animal warm, and drench with ale and laudanum a drachm. Calves are also very subject to diarrhœa or *scouring*, which will readily yield to the usual medicines. (6552.)

SECT. II. *The Buffalo*. — *Bòs búbulus L.* *Buffle*, Fr.; *Buffalo*, Span.; *Büfflochs*, Ger.; and *Bufle*, Ital.

6973. *The buffalo* is found wild in India, America, and various parts of the globe, and is in some degree domesticated in many countries. He is gregarious, docile, alert, and of surprising strength; his carcass affords excellent beef; and the horns, which are jet black, and of a solid consistence, take a polish of wonderful beauty: they can be converted into fabrics of use and ornament, such as mugs, tumblers, knife-handles, &c. In this way they sometimes apply them; and when ornaments of silver or mother-of-pearl are employed, the contrast with the polished black of the horn is agreeably striking. The boss on the shoulders is, as well as the tongue, extremely rich and delicious, and superior to the best English beef. It is usual to cure the tongues for sale. The buffalo far surpasses the ox in strength. Judging from the extraordinary size of his bones, and the depth and formation of his chest, some consider him twice as strong as the ox; and, as an animal of labour, he is generally preferred in Italy. In this country the ingenious physiologist, Hunter, has caused buffaloes to be trained to work in a cart. At first they were restive, and would even lie down; but afterwards they became steady, and so tractable, that they were driven through the streets of London, in the loaded cart, as quietly and steadily as in Italy or India.

6974. *The buffalo* is kept in several gentlemen's parks as an object of luxury, and has been trained and worked by Lords Sheffield, Egremont, and some other amateur agriculturists. Many prefer his flesh, and some his milk, to that of the bull family.

6975. *The breeding, rearing, and general treatment* of the buffalo may be the same as those of the bull family.

CHAP. V.

The Dairy and its Management.

6976. *The manufacture of butter and cheese* is of necessity carried on where the milk or raw material is at hand. The subject therefore forms a part of farm management, more or less on every farm; and the principal one in dairy farms. In most of those counties where the profit of the cow arises chiefly from the subsequent manufacture of the milk, the whole care and management of the article rests with the housewife, so that the farmer has little else to do but to superintend the depasturing of his cattle; the

milking, churning, and in short the whole internal regulation of the dairy, together with the care of marketing the butter, where the same is made up wholly for home consumption, falling alone upon the wife. In this department of rural economy, so large a portion of skill, of frugality, cleanliness, industry, and good management, is required in the wife, that without them the farmer may be materially injured. This observation will indeed hold good in many other parts of business which pass through the hands of the mistress in a farm-house; but there is none wherein he may be so greatly assisted, or so materially injured, by the good conduct or want of care in his wife, as in the dairy. The dairy husbandry is more extensively and successfully pursued in England than in Scotland or in Ireland. "As to dairy husbandry on any thing like an improved plan," says Aiton, "it is still confined to a mere corner of Scotland." This corner is the district of Cunninghame, in Ayrshire, of which he observes: "The excellence of the improved breed of cows in Ayrshire, as well as the superior quality of Strathaven veal, the Glasgow butter and milk, and Dunlop cheese, to all others in Scotland, are things that cannot be disputed." (*Aiton's Dairy Husbandry, Pref. p. 18.*) We shall in giving the dairy husbandry of England glance, at the same time, at the peculiarities of the Ayrshire dairy husbandry, as given by the author last quoted.

6977. *The operations of the dairy* in all its branches are still conducted perhaps more empirically than those of any other department of husbandry, though it would appear that science, chemistry in particular, might be applied to discover the principles, and regulate the practice, of the art, with facility and precision. We have heard it admitted, an eminent author observes, even by experienced dairymen, that the quality of their cheeses differs materially in the same season, and without being able to assign a reason. Every one knows how different the cheese of Gloucester is from that of Cheshire, though both are made from fresh milk, the produce of cows of the same breed, or rather, in both counties, of almost every breed, and fed on pastures that do not exhibit any remarkable difference in soil, climate, or herbage. Even in the same district, some of what must appear the most important points are far from being settled in practice. Marshal, in his *Rural Economy of Gloucestershire*, has registered a number of observations on the heat of the dairy-room, and of the milk when the rennet was applied in cheese-making; on the time required for coagulation, and the heat of the whey after, which are curious, only because they prove that no uniform rule is observed in any of these particulars. The same discrepancy is observable in all the subsequent operations till the cheese is removed from the press, and even afterwards in the drying room. One would think the process of salting the cheeses the most simple of all; and yet it is sometimes, as in the west of Scotland, mixed with the curd; in other instances poured into the milk, in a liquid state, before being coagulated; and still more commonly, never applied at all till the cheeses are formed in the press, and then only externally. In treating of the dairy, we shall first offer a few remarks on the nature of milk, and the properties of that of different animals; and next consider the dairy house and its furniture, milking, churning, cheese-making, and the different kinds of cheese, butters, creams, and other products of the dairy.

SECT. I. *Chemical Principles of Milk, and the Properties of the Milk of different Animals.*

6978. *The milk* used by the human species is obtained from various animals, but chiefly the cow, ass, ewe, goat, mare, and camel; that in most general use in British dairying is the milk of the cow, which in modern times has received great improvement in quantity as well as quality, by ameliorations in the form of milch cows, in their mode of nourishment, and in the management of the dairy. Whatever be the kind of animal from which milk is taken, its external character is that of a white opaque fluid, having a sweetish taste, and a specific gravity somewhat greater than that of water. Newly taken from the animal, and allowed to remain at rest, it separates into two parts; a thick white fluid called cream, which collects on the surface in a thin stratum; and a more dense watery body, which remains below. The quantity and quality of cream, and the time it requires to separate from the milk, vary according to the nature of the milk and the temperature of the atmosphere. Milk which has stood some time after the separation of the cream, first becomes acescent, and then coagulates. When the coagulum is pressed gently, a serous fluid is forced out, and the remainder is the caseous part of milk, or pure cheese.

6979. *Butter*, or solidified cream, one of the most valuable products of milk, is obtained artificially by churning; an operation analogous in its effects to shaking or beating, by which the cream separates from the caseous part and serum, in a more solid form than when left to separate spontaneously. It is afterwards rendered still more solid by beating with a wooden spatula.

6980. *Cheese* is obtained by first coagulating the milk, either with, or deprived of, its cream, and then expressing the serum or whey; the consolidated curd so produced forms cheese. The milk may be coagulated in various ways, but that effect is chiefly produced by the use of rennet, which is prepared by digesting the coat of young ruminating animals, especially that of the calf. The rennet is poured into the milk when newly brought from the cow, or the milk is warmed to 90° or 100° for that purpose. The richness of cheese depends on the quantity of cream which the milk may have contained; its quality of keeping on the quantity of salt added; and the degree of pressure used to exclude the whey.

6981. *Whey* expressed from coagulated milk, if boiled, and the whole curd precipitated, becomes transparent and colourless. By slow evaporation it deposits crystals of sugar, with some muriate of potash, muriate of soda, and phosphate of lime. The liquid which remains after the separation of the salts is converted by cooling into a gelatinous substance. If whey be kept it becomes sour, by the formation of an acid, which is called the lactic acid; and it is to this that the spontaneous coagulation of milk, after it remains at rest, is owing. Milk may, after it is sour, be fermented, and it will yield a vinous intoxicating liquor. This is practised by the inhabitants of the most northerly islands of Europe, with buttermilk, and by the Tartars with the milk of the mare. Milk is likewise susceptible of the acetous fermentation.

6982. *The constituent parts of milk* are found to be oil, curd, gelatine, sugar of milk, muriate of soda, muriate of potash, phosphate of lime, and sulphur. These substances enter into the milk of all animals, but the proportions vary in different species. The various milks in use as food are thus distinguished:—

6983. *Cow's milk* produces a copious, thick, and yellow cream, from which a compact consistent butter is formed; the curd is bulky, and retains much serum, which has a greenish hue, a sweet taste, and contains sugar of milk and neutral salts. The milk of the buffalo is essentially the same as that of the cow.

6984. *Ass's milk* throws up a cream resembling that of woman's milk; the butter made from it is white, soft, and disposed to be rancid; the curd is similar to that of the woman, but not unctuous; the whey is colourless, and contains less salts, and more sugar, than that of the cow.

6985. *Ewe's milk* throws up as much cream as that of the cow, and of nearly the same colour; the butter made from it is yellow and soft; the curd is fat and viscid; the whey is colourless, and contains the smallest quantity of sugar of any milk, and but a small portion of muriate and phosphate of lime.

6986. *Goat's milk* produces abundance of cream, which is thicker and whiter than that from the cow;

the butter is white and soft, and equally copious, and so is the curd, which is of a firmer consistence than that of the cow, and retains less whey.

6987. *Mare's milk* produces a very fluid cream, similar in colour and consistence to good cow's milk before the cream appears on the surface; the butter made from it has but little consistence, and is readily decomposed. The curd is similar to that obtained from woman's milk, and the whey has little colour, and contains a large proportion of saccharine matter, and of saline substances.

6988. *Camel's milk* throws up little cream, which is whitish and thin, affording insipid whitish butter; the curd is small in quantity, and contains but little whey, which is colourless and somewhat saccharine.

6989. *Sow's milk*. In China, especially about the city of Canton, no other milk can be had but that of the sow. It is rather sweeter than cow's milk, but very similar in all other respects.

6990. *In the use of these milks*, that of the camel is chiefly confined to Africa and China, and that of the mare to Tartary and Siberia. In India the milk of the buffalo is preferred by the natives to that of the domestic cow. The milk of the goat is more generally used in Italy and Spain than in any other countries in Europe; they are driven into Leghorn, Florence, Madrid, and other towns, in flocks early in the morning, and milked in the streets. The goat will allow herself to be suckled by the young of various other animals, and a foal which has lost its mother has been suckled by a goat, placed on a barrel to facilitate the operation. As the butter of goat's milk contains a larger proportion of gelatine, and less oil than that of the cow, it is recommended by physicians as nearly equally light as ass's milk; it is the most prolific of all in curd, and forms excellent cheese; but it is an error to suppose that the Parmesan (a skim-milk cheese) is made from it. Ewe's milk is gradually wearing out of use, though it makes excellent cheese, and some milking ewes as well as goats might be kept for that purpose, by those who have extensive up-land grass-lands. The milk of the ass comes the nearest to that of the woman, and being the lightest of any is much recommended in pulmonary and hepatic affections. Soda water and warm cow's milk is taken as a substitute, and found almost equally light. The milk in universal use, as an article of food in Britain, is that of the cow.

6991. *Lactometers* for ascertaining the value of milk, relatively to butter and cheese, will be described among the utensils of the dairy in the succeeding section.

SECT. II. *The Dairy House, its Furniture and Utensils.*

6992. *The dairy house, for general purposes*, consists of at least three separate apartments, the milk room, the dairying or working room, and the cheese or store-room. The two former are generally separated by a passage or lobby; and the latter is very frequently a loft over the whole, entered by a stair from the lobby.

6993. *The properties requisite in a good milk-house* are, that it be cool in summer, and moderately warm in winter, so as to preserve a temperature nearly the same throughout the whole year, or about 45 degrees; and that it be dry, so as to admit of being kept clean and sweet at all times. For these reasons a northern exposure is the best, and this as much under the shade of trees or buildings as possible; if it can be so situated that the sun can have no influence either on the roof or walls, so much the better.

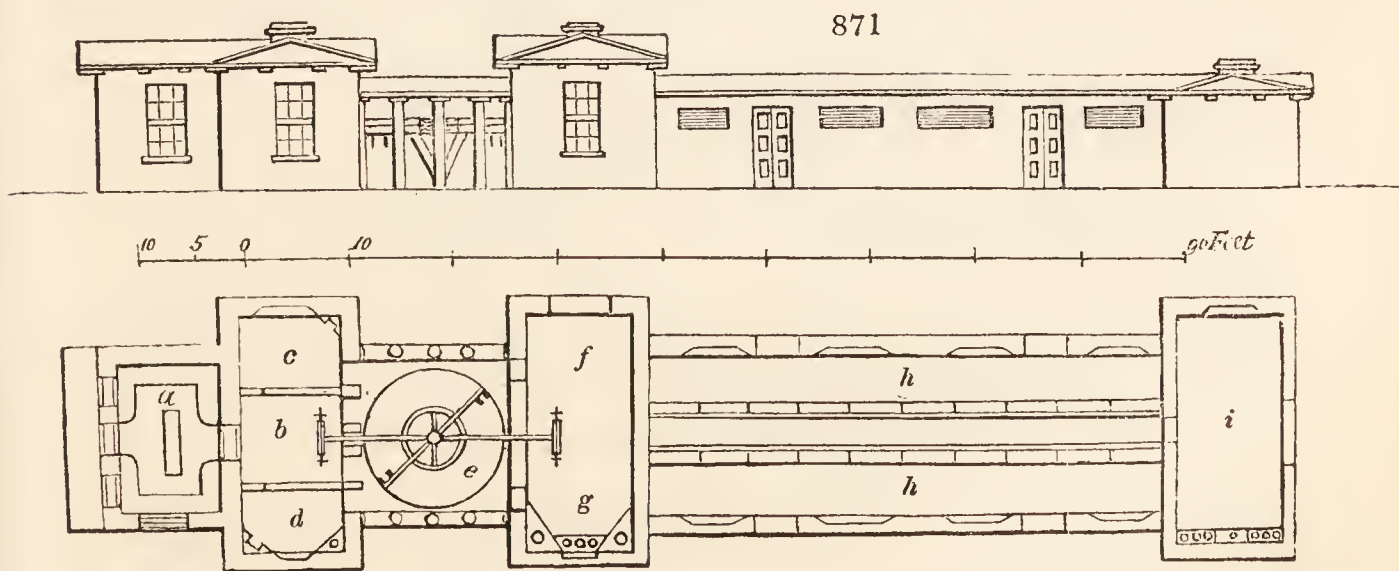
6994. *A well constructed butter dairy* should consist of three apartments; a milk-house, a churning-house, with proper boiler, as well as other conveniences for scalding and washing the implements, and a room for keeping them in, and for drying and airing them, when the weather will not permit of its being done without doors.

6995. *The cheese dairy* should likewise consist of three apartments; a milk-house, a scalding and pressing-house, and a salting-house. It is essential to the cheese dairy to have a command of heat during the cold season. When milk is exposed to a degree of cold below 50° at any time, from the moment it is drawn from the cow, till the cheese is not only pressed, but, to a great extent, dried, the cheese will not be good. "It is not enough that the milk be again heated; it must never be allowed to become too cold at any time, not even in the press; or if it is, the quality of the cheese will be much injured." (*Aiton's Dairy Husb.* p. 82.) To these should be added a cheese-room or loft, which may with great propriety be made above the dairy. This is, however, generally separate from the dairy. But a milk dairy requires only a good milk-house, and a room for scalding, cleaning, and airing the utensils. The size of the milk-house, according to Aiton, ought to be sufficient to contain one day's milk of all the cows belonging to it.

6996. *A dairy for the private use of any farmer* or family need not be large, and may very economically be formed in a thick walled dry cellar, so situated as to have windows on two sides, the north and east in preference, for ventilation; and in order that these windows may the better exclude cold in winter, and heat in summer, they should be fitted with double sashes, and on the outside of the outer sash should be a fixed frame of close wire netting, or hair cloth, to exclude flies and other insects.

6997. *Of dairies for dairy farmers* there are different sizes and shapes.

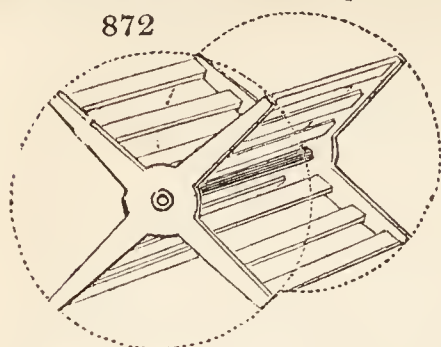
6998. *A dairy-house connected with a cow-house*, and mill for preparing food for the cows, churning, and washing the family linen, is thus arranged. (*fig. 871.*) The dairy (*a, b, c, d*) is at the north end, has



hollow walls, double doors, double sashed windows, and an ice-house under. The milk room (*a*) is surrounded by milk coolers, and has a butter slab and jet in the centre. The jet is supplied from a cistern over the steaming house (*f, g*), to which the water is raised from a well by a forcing-pump worked by the

gin wheel. Besides supplying the jet, it furnishes, by cocks and pipes, water for the usual dairy purposes, the steaming or boiling of food for the cows, their drink, and washing out the cow-house, the washing machine, &c. The churning room (b), is separated from the milk-room by double doors, as is the latter from the cheese-room (c) and store closet (d). The gin wheel (e) is worked by one or two horses, or oxen or asses, according to the work to be done. The steaming and washing room (f, g) is a large roomy apartment properly fitted up, and furnished with two boilers, a machine for steaming cattle food, another for washing linen by steam; one impelled by the gin wheel operating on an axle with beaters or lifters (fig. 872.), and a cylinder of open spars, which turns round in a box of water for washing potatoes or other roots. The cow-house (h, h) is calculated for forty cows to be fed from a broad passage in the centre. At the south end is a large apartment (i) open to the roof for hay, straw, green herbage for soiling, turnips, and other food; and under it is an urinarium vaulted, and from which the liquid is drawn by a Buchanan pump (4494.) outside of the building, and some yards distant.

872



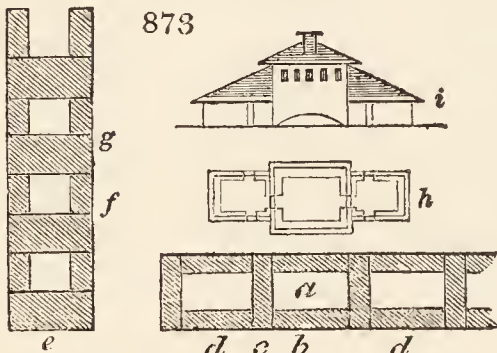
6999. The dairy-house recommended by Dr. Anderson is surrounded by double walls, the inner of brick or stone, nine inches or a foot in thickness; and the outer about two feet distance, built of stone or turf; or a bank of earth faced with turf may be placed against the inner walls.

7000. The size of the dairy house should vary according to that of the number of cows. Marshal found in Gloucestershire one for forty cows to be twenty feet by sixteen, and one for one hundred, thirty by forty. The North Wiltshire dairy-rooms have in general, he says, outer doors, frequently opening under a pent-house or open lean-to shed; which is a good conveniency, affording shade and shelter, and giving a degree of coolness to the dairy room. In one instance he observed two doors: a common close-boarded door on the inside, and an open-paled gate-like door on the outside; giving a free admission of air in close warm weather, and, at the same time, being a guard against dogs and poultry. A conveniency which, he thinks, would be an improvement to any dairy room in the summer season. The inside wall may be seven or eight feet high in the sides, on which may be placed the couples to support the roof, and the walls at the gables carried up to the height of the couples. Upon these should be laid a roof of reeds, or thatch, that should not be less than three feet in thickness, which should be produced downward till it covers the whole of the walls on each side to the ground: but here, if thatch or reeds be not in such plenty as could be wished, there is no occasion for laying it quite so thick. In the roof, exactly above the middle of the building, should be placed a wooden pipe of a sufficient length to rise a foot above the roof, to serve occasionally as a ventilator. The top of this funnel should be covered, to prevent rain from getting through it, and a valve fitted to it, that by means of a string could be opened or shut at pleasure. A window also should be made upon one side for giving light, to be closed by means of two glazed frames, one on the outside, and the other on the inside. The use of this double sash, as well as the great thickness of the wall, and of the thatch upon the roof, are to render the temperature of this apartment as equal as possible at all seasons of the year, by effectually cutting it off from having any direct communication with the external air.

7001. The dairy-house made use of by Wakefield of Liverpool contains three apartments; a milk-house, churning-room, and the room for the utensils. In the milk-house were the coolers; a slab for laying butter on after it is made up; cocks for drawing off the milk from the coolers; a large cock to throw water on the floor, which slopes a little from that part; cocks at the back part of the coolers, for letting in water; a door, latticed; and another door most commonly used, but panelled. In the churning-room is a fire-place, a boiler, a large copper, also used when brewing. The room for drying or airing the utensils is also used occasionally as a laundry. Over the whole are apartments for the servants.

7002. A very neat dairy for a private family may be made under the shade of two or three tall trees, in the following manner: — Build the walls of bricks, and hollow in Silverlock's manner, by which every course of brick-work is laid on edge, and forms oblong cavities (fig. 873. a), the bricks of the one course being laid alternately lengthways (b), and crossways (c), and those of the next breaking joint with these, by the cross ones being placed on the middle of the long ones (d). The elevation of such a wall (e, f, g) should of course be founded on solid work, of breadth and thickness according to the height of the wall, and nature of the foundations. The plan of a dairy with such walls should contain the three usual apartments for milk, churning, and utensils (h), and should have double doors and windows: the latter guarded by fly-wire. The elevation (i) may be of any style of simple architecture.

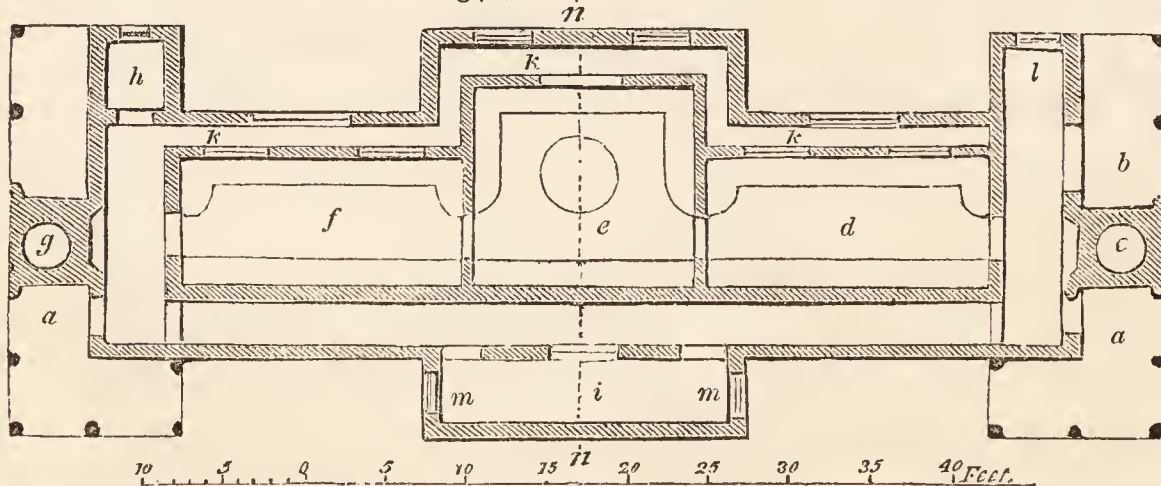
873



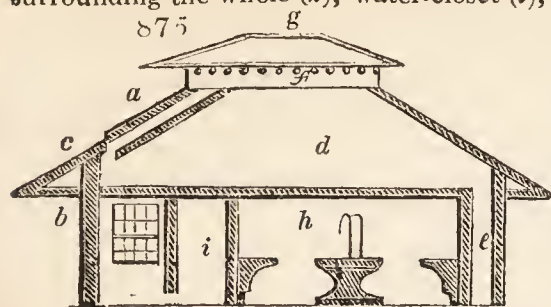
7003. As a complete dairy on a large scale, we submit the following. The plan (fig. 874.) is of an oblong form, and consists of the three usual principal apartments, enclosed by walls of four inches in thickness, and surrounded by a passage two feet wide to the north, and three feet to the south, which is again surrounded by a nine-

inch wall. The passages communicate with the roof by covered openings, in the ridge of which and by the windows ventilation is completely effected. In detail, the plan exhibits two principal entrance porches (a), back entrance (b), copper for heating water (c), churning-room (d), milk-room (e), utensils

874



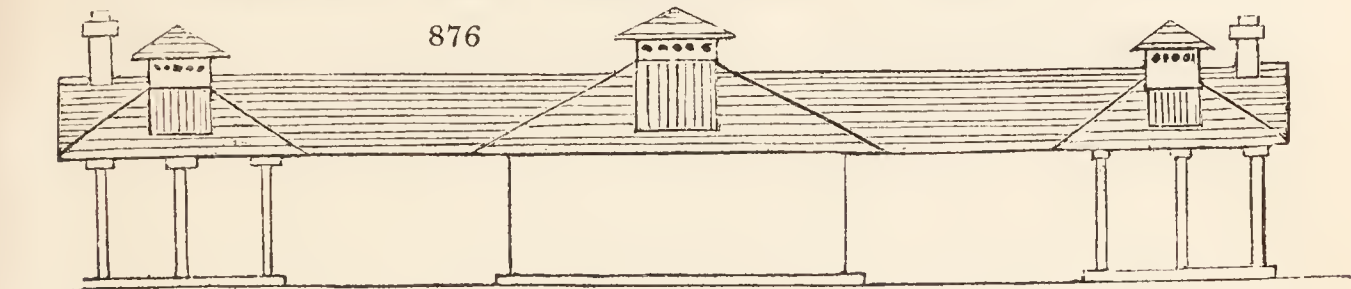
and cheese-press (*f*), boiler for heating milk (*g*), store closet or butter-room (*h*), cheese-room (*i*), passage surrounding the whole (*k*), water-closet (*l*), and windows to cheese-room (*m*).



7004. A section (*fig. 875.*) taken across the milk-room (*fig. 874. n n*) exhibits the ventilating funnel in the roof (*a*), projecting eaves (*b, c*), cheese-room (*d*), passage on the north side (*e*), raised part of the roof for ventilation (*f, g*), fountain in the centre of the dairy (*h*), and south passage (*i*).

7005. The elevation (*fig. 876.*) presents a simple shed roof, varied, however, by projections and recesses: it presents no windows or doors to the south, and therefore that side, if other circumstances permit, may be covered with vines or other fruit-trees, or with ornamental creepers.

7006. The fixtures of the dairy are, in the scalding-room, a copper boiler fixed over a



fire-place, for boiling water to wash and scald the utensils; next, some benches and shelves in this room and the cheese-room; and a bench or table not more than two feet wide surrounding the milk-room. It is very desirable, also, that there should be a jet, or fountain, or pump, or spring, in the centre of the milk-room, in order to cool down the air in summer, and to supply clear water at a moderate temperature at all times.

7007. The utensils of the dairy are, pails for milking into; sieves of hair-cloth or silver wire-cloth for passing the milk through, to free it from hairs and other impurities; milk dishes, or coolers, for holding the milk till it throws up its cream; a cream-knife of ivory for separating, and skimming dishes of willow or ivory for removing, the cream; bowls and barrels for holding it, or other preparations of milk-churns, butter-makers, butter-prints; one or more tubs for hot or cold water, in which to immerse vessels that require extraordinary purification; and a portable rack for drying dishes in the open air. All these utensils are requisite where butter only is to be produced.

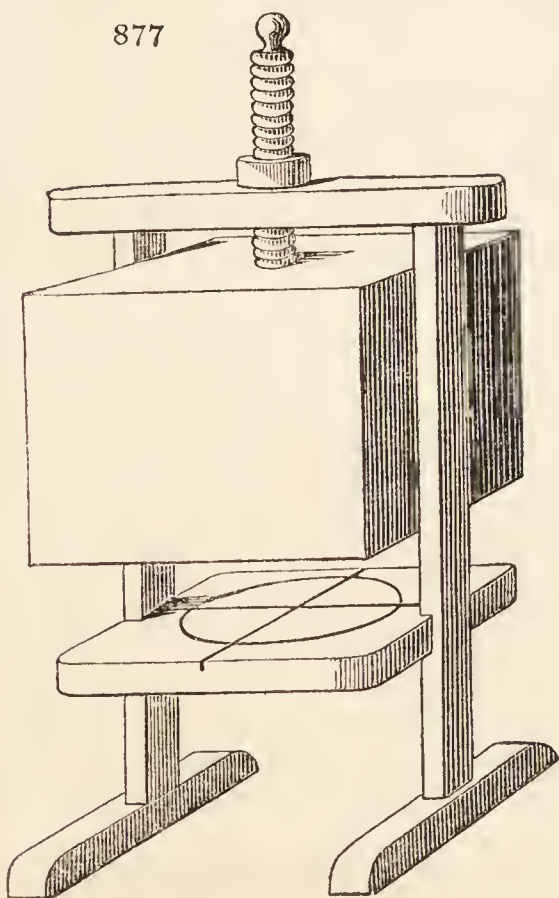
7008. The utensils requisite if cheese is to be made, are the cheese-tub, in which the curd is broken, and prepared for being made into cheese; the cheese-knife, generally a thin spatula of wood, but sometimes of iron, used for the purpose of cutting or breaking down the curd while in the cheese-tub. The cheese-cloth is a piece of thin gauze, like linen cloth, in which the cheese is placed in the press; the cheese-board is circular, and on it the cheeses are placed on the shelves of the cheese-room; their diameter must be somewhat less than that of the interior or hoop part of the vat. The vat is a strong kind of wooden hoop with a bottom, which, as well as the sides, is perforated with holes to allow the whey to escape while the cheese is pressing: the size of vats must depend on that of the cheese and the number required, as of most of the other implements on the extent of the dairy.

The cheese-press (*fig. 877.*) is a power generally obtained by a screw, though sometimes by a dead weight, and is used for forcing the whey from the curd while in the vat. The cheese-tongs is a wooden frame, occasionally placed on the cheese-tub, when the vat is set on it in order to drain the whey from the curd. To these implements some add a lactometer, one kind of which (*fig. 878.*), is a glass tube long with a funnel at top.

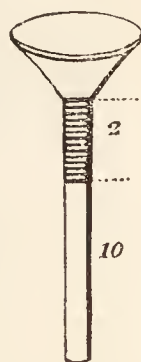
The upper two inches of the tube are marked in small divisions, and when the instrument is filled to the height of one foot with milk, the depth of cream it yields is noted by the gradations on the upper part. Another lactometer "for ascertaining the richness of milk from its specific gravity, by its degree of warmth taken by a thermometer, on comparing its specific gravity with its warmth," was invented by Dicas, of Liverpool, but never came into use. Another invention for the same purpose was made by Mrs. Lovi, of Edinburgh, in 1816. It consists of areometric beads, by which the specific gravity of the milk is tried first when new-milked, and next when the cream is removed. When milk is tried as soon as it

cools, say to 60°, and again, after it has been thoroughly skimmed, it will be found that the skimmed milk is of considerably greater gravity; and as this increase depends upon the separation of the lighter cream, the amount of the increase, or the difference between the specific gravity of the fresh and skimmed milk, will bear proportion to, and may be employed as a measure of, the relative quantities of the oily matter or butter contained in different milks. The specific gravity of skimmed milk depends both on the quantity of the saccharo-saline matters, and of the curd. To estimate the relative quantities of curd, and by that determine the value of milk for the purpose of yielding cheese, it is only required to curdle the skim-milk, and ascertain the specific gravity of the whey. The

877



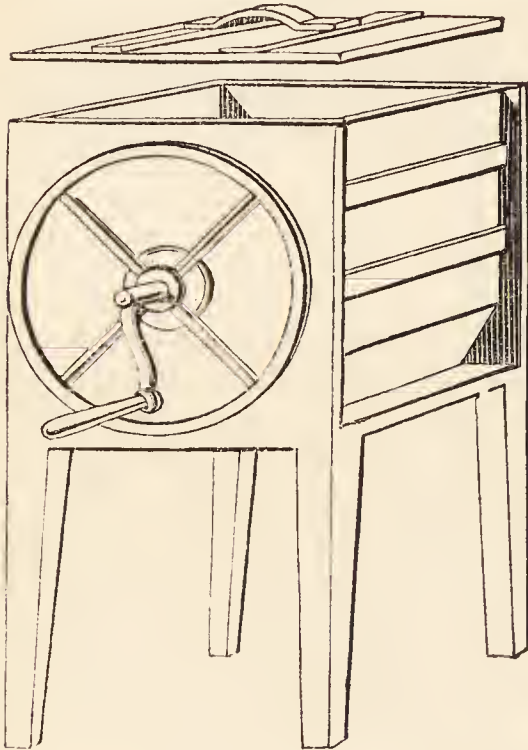
878



they will, of course, be found of lower specific gravity than the skimmed milk, and the number of degrees of difference affords a measure of the relative quantities of the curd. According to this hypothesis, the areometric beads may be employed to ascertain the qualities of milk, relatively both to the manufacture of butter and cheese. (*Trans. of the High. Soc.* sect. v. part i.)

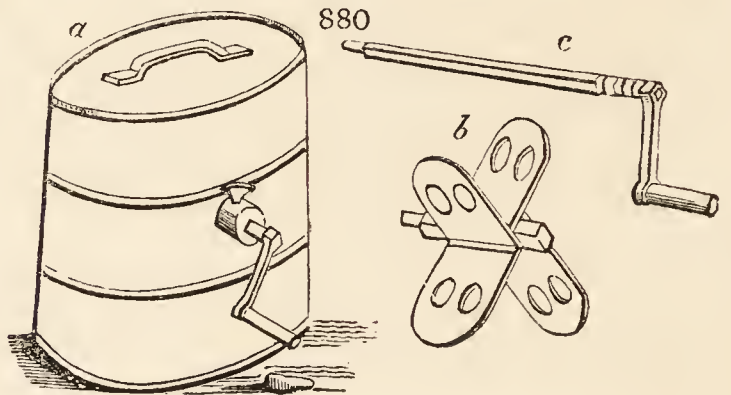
7009. In milk coolers and churns there is considerable variation of form. Milk coolers are generally made of earthenware or wood; but of late years they have been formed of lead, marble, slate, and cast-iron. Their general form is round, and diameter from one to two feet; but in extensive dairies they are often made several feet or yards in length, and from two to three feet wide, with holes at one or more corners to admit the escape of the milk after the cream is removed. The safest dish is wood, though it requires most labour to keep it sweet; next is earthenware or China, though on the leaden glaze of the former the acid of the milk is apt to operate. Leaden dishes or troughs, though very general in Cheshire, are the most dangerous; and the objection to slate coolers is the joinings of the plates, which are always unsightly, imperfect, and liable to be operated on by the lactic acid. The annealed and tinned cast-iron dishes of Baird's invention (in 1806), and which are now becoming universal in Scotland (*Aiton's Dairy H.*, p. 81.), are perhaps the best for such as do not choose to go to the expense

879



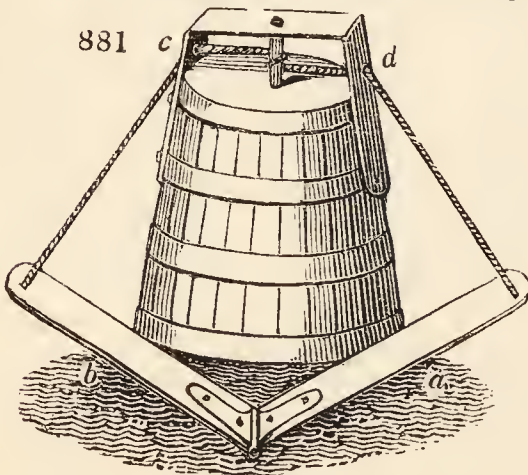
of China dishes. They are durable from the nature of the material, not liable to be broken by falls by being annealed, easily kept clean from being turned smooth, and also very economical, and said to throw up more cream from a given quantity of milk than any other.

7010. Besides the common plunge and barrel churns, there are various improved sorts. One of the best for using on a small scale is the patent box churn (*fig. 879.*); and on a large scale, the plunge churn, worked by levers put in motion either by a man or horse. The Derbyshire churn (*fig. 880.*), which works on the principle of the barrel churn, is an excellent implement on a large scale. The bottom is a segment of a circle, and the advantage of the plan is, that when the butter is made, the lid (*a*) being



removed, the beaters (*b*) may be taken out at pleasure by withdrawing the spindle (*c*) to admit the removal of the butter, or the cleaning and scalding of the churn.

7011. The Lancashire plunge churn (*fig. 881.*) is a simple and effective implement, worked by the operator standing on the levers (*a, b*), throwing his whole weight alternately on each, so as by means of the line (*c, d*) connected with the churn staff to raise it and turn it round, and lower it and turn it round alternately.



7012. The most exquisite cleanliness in the dairy is an essential requisite, as to the walls, floor, shelves, benches, and in the different utensils.

7013. The milk coolers and all the dishes in which milk is put, as well as the churn, must be scalded, scrubbed, rinsed, and dried every time they are used. Scalding is less frequently requisite in the cheese utensils, but they also must be almost daily washed in hot water, dried, and aired. When any vessel becomes tainted with the acidity of milk, it operates like leaven on what is put into it: if this taint cannot be removed by ordinary scalding, it may be boiled or immersing in water impregnated with alkali; but afterwards it must be well boiled, or a day or two immersed in pure water.

SECT. III. Milking and the general Management of Milk.

7014. The times of milking vary greatly in different districts. In most places cows are milked twice in twenty-four hours throughout the year; but in the best managed dairies where they are abundantly fed, they are milked at morning, noon, and the approach of night: the additional quantity thus obtained is very considerable, but according to the experiments of Parmentier it must be inferior in quality; for he found twelve hours requisite for the due preparation of the milk in the cow. Where quantity of milk or cheese is an object, three times milking must be decidedly preferable; but it is certain that in the best butter districts of England the cows are only drawn twice a day, between five and six o'clock morning and evening. Whatever may be the times of milking, it is essential that the milk be drawn off clear; for if the milk which the cow can be made to yield at the time be not completely taken away, the quantity left will be reabsorbed into the system, and no more will be generated than is necessary to supply the quantity actually drawn off.

7015. The operation of milking is performed by men in many districts, but taking Britain generally it is more commonly the work of women. The milker, whether a man or woman, ought to be mild in manners and good tempered. If the operation be performed harshly, it becomes painful to the cow, who in this

case often brings into action her faculty of retaining her milk at pleasure; but if gently performed, it seems rather to give pleasure, as is exemplified on a large scale in Tiviotdale, and Switzerland, where the cows come to be milked at the call of the milkers. Many instances have occurred, Dr. Anderson observes, in which cows would not let down a single drop of milk to one dairy-maid, which let it flow in abundance whenever another approached them; exhibiting unequivocal marks of satisfaction in the one case, and of sullen obstinacy in the other. For the same reason, when cows are ticklish, they should be treated with the most soothing gentleness, and never with harshness or severity; and, when the udder is hard and painful, it should be tenderly fomented with luke-warm water, and stroked gently, by which simple expedient the cow will be brought into good temper, and will yield her milk without restraint. Lastly, as it sometimes happens that the teats of cows become scratched or wounded, so as to produce foul or corrupted milk, whenever this is the case, such milk ought on no account to be mixed with the sweet milk, but should be given to the pigs, without being carried into the milk-house; lest, by continuing there, it should taint the atmosphere, and consequently prove injurious to the rest of the milk.

7016. *To promote cleanliness in regard to milking*, cows are in some places curried, combed, brushed, and clothed like horses; before milking, their udders and teats are washed and dried, and their tails trussed up. It would be well if a part of this refinement were adopted in all dairies; that of using the comb and brush, and washing the udder, is indispensable in every establishment where clean milk is an object. According to Mowbray, snuff-takers, sluts, and daudles are unfit to be dairy-women, and no milker should ever be suffered to enter the dairy in a dirty apron covered with hairs from the cow-house.

7017. *The following aphorisms respecting the management of milk in the dairy are from the "Recreations" of Dr. Anderson, one of the most scientific writers on this subject.*

1. Of the milk drawn from any cow at one time, that part which comes off at the first is always thinner, and of a much worse quality for making butter, than that afterwards obtained; and this richness continues to increase progressively to the very last drop that can be obtained from the udder.

2. If milk be put into a dish, and allowed to stand till it throws up cream, the portion of cream rising first to the surface is richer in quality, and greater in quantity, than that which rises in a second equal space of time: and the cream, which rises in the second interval of time, is greater in quantity, and richer in quality, than that which rises in a third equal space of time; that of the third is greater than that of the fourth, and so of the rest; the cream that rises continuing progressively to decrease in quantity, and to decline in quality, so long as any rises to the surface.

3. Thick milk always throws up a much smaller proportion of the cream which it actually contains than milk that is thinner; but the cream is of a richer quality: and if water be added to that thick milk, it will afford a considerably greater quantity of cream, and consequently more butter than it would have done if allowed to remain pure; but its quality is, at the same time, greatly debased.

4. Milk, which is put into a bucket or other proper vessel, and carried in it to a considerable distance, so as to be much agitated, and in part cooled before it be put into the milk-pans to settle for cream, never throws up so much, or so rich cream, as if the same milk had been put into the milk-pans directly after it was milked.

7018. *From these fundamental facts*, the reflecting dairyist will derive many important practical rules. Some of these we shall enumerate, and leave the rest to be discovered. Cows should be milked as near the dairy as possible, in order to prevent the necessity of carrying and cooling the milk before it is put into the creaming dishes. Every cow's milk should be kept separate till the peculiar properties of each is so well known as to admit of their being classed, when those that are most nearly allied may be mixed together. When it is intended to make butter of a very fine quality, reject entirely the milk of all those cows which yield cream of a bad quality, and also keep the milk that is first drawn from the cow at each milking entirely separate from that which is last obtained, as the quality of the butter must otherwise be greatly debased without materially augmenting its quantity. For the same purpose, take only the cream that is first separated from the first drawn milk. Butter of the very best quality can only be economically made in those dairies where cheese is also made; because in them the best part of each cow's milk can be set apart for throwing up cream, the best part of this cream can be taken in order to be made into butter, and the remainder, or all the rest of the milk and cream of the dairy, can be turned into cheese. The spontaneous separation of cream, and the production of butter, are never effected but in consequence of the production of acid in the milk. Hence it is that where the whole milk is set apart for the separation of cream, and the whole of the cream is separated, the milk must necessarily have turned sour before it is made into cheese; and no very excellent cheese can be made from milk which has once attained that state.

SECT. IV. *Making and Curing of Butter.*

7019. *The milk from which butter is to be made* may either be put at once into the churn, and left there till it send up the cream; or it may be made to cream in milk dishes, and the cream alone churned.

7020. *The last is generally considered the best mode*, and in carrying it into effect, the milk being drawn from the cow, is to be strained into the creaming dishes, which should never be more than three inches deep, and of about a gallon and a half or two gallons in capacity. In general the best cream will be fit for removal in seven or eight hours, though for ordinary good butter it may stand twelve hours; but where the very best butter is wished, and such arrangements are formed as admit of converting the milk to cheese, or some other use while it is sweet, it may be separated after standing only two or three or four hours. In performing the operation, first pass the cream knife round the edges of the vessel, to separate the adhering stratum of cream, and then draw it to one side, lift it off with the skimming dish, and put it in the cream bowl to be carried to the cream barrel.

7021. *Cream* may be kept from three to seven days before it is churned. Where quantity more than quality is desired, the whole of the milk is churned, without separating any cream; the milk is kept in the churn or in large barrels for two or three days, till it begins to get sour. The operation of churning, where the cream and milk are both to agitate, is necessarily tedious and laborious; but a great weight of butter is undoubtedly obtained, the quality and flavour of which will depend a good deal on the peculiar properties of the milk. The milk of Galloways, Ayrshires, and Alderneys, so treated, makes excellent butter.

7022. *In the process of churning great nicety is required*; a regular stroke in plunge or pump churns, and a regular motion in those of the barrel or turning kind, must, if possible, never be deviated from. A few hasty irregular strokes or turns has been known to spoil what would otherwise have been excellent butter. Twanley (*Essays on the Dairy*) recommends the selection of a churner of a cool phlegmatic temper, of a sedate disposition and character; and advises never to allow any individuals, especially the young, to touch the churn without the greatest caution and circumspection. To those who have been accustomed to see cream churned without being properly prepared, churning may, perhaps, appear to be severe labour for one person in a large dairy; but nothing is more easy than the process of making butter, where the cream has been duly prepared.

7023. *The best time for making butter, during summer*, is early in the morning, before the sun acquires much power; and if a pump churn be used, it may be plunged a foot deep into a tub of cold water, where

it should remain during the whole time of churning; which will very much harden the butter. During winter, from the equality of temperature, which (if it be properly managed) will generally prevail in a dairy, it will very rarely, if ever, be necessary to churn near the fire. Should any circumstance, however, require this, care should be taken not to churn so near the fire as to heat the wood; as it would impart a strong rancid taste to the butter. As soon as the butter is made, it must be separated from the milk, and be put into a clean dish; the inside of which, if of wood, should previously be well rubbed with common salt, to prevent the butter from adhering to it. The butter should then be pressed and worked with a flat wooden ladle or skimming-dish, having a short handle, so as to press out all the milk that may be lodged in the cavities of the mass. A considerable degree of dexterity, as well as of strength, is requisite in this manipulation: for, if the milk be not entirely removed, the butter will infallibly spoil in a short time; and if it be much worked, the butter will become tough and gluey, which greatly debases its quality. In some places it is the practice to beat up the butter with two flat pieces of board, which may, perhaps, answer very well. In this operation, some persons pour cold water upon the butter, for the purpose of washing it: this practice, however, is not only useless, for the butter can be perfectly cleared of the milk without it, but it is also pernicious, and debases the quality of the butter in an astonishing degree. Nothing is so detrimental in a dairy as water improperly used; which, if mixed in any way, either with milk or butter, tends greatly to debase the quality of the latter.

7024. *The best temperature for churning butter* has been very satisfactorily determined by a number of experiments, sanctioned by the *Highland Society of Scotland*, and published in their *Transactions*. From these experiments it is concluded, that the most proper temperature at which to commence the operation of churning butter is from 50° to 55° ; and that at no time in the operation ought it to exceed 65° : while, on the contrary, if at any time the cream should be under 50° in temperature, the labour will be much increased, without any proportionate advantage being obtained; and a temperature of a higher rate than 65° will be injurious, as well to the quality as the quantity of the butter. (*Highl. Soc. Trans.* vol. vii. p. 198.)

7025. *The making up of butter* is the next process.

7026. *Before being sent to table or market*, sweet or fresh butter is made up into various forms; sometimes into rolls or cylinders, six or eight inches long, and from half an inch to two inches in diameter; at other times into small round figures, or casts, with impressions in relief from butter moulds. When the butter is too soft for the last purpose, it may be put into small wooden vessels, which may be allowed to swim in a tub or cistern of cold water; or they may be set in an ice-house for an hour or two; or the water in which the small vessels float may be iced. At all events, whatever mode is adopted, no water ought to be allowed to touch the butter. When formed into the desired shapes, it may be placed in dishes, and set in the margin of the central cistern of water till wanted.

7027. *In salting or curing butter* the use of wooden vessels is preferable; and these vessels should be made from timber which has been previously boiled for four hours, to free it from the pyroligneous acid; or they should be formed from the lime tree, which is confidently asserted (*Highl. Soc. Trans.* vol. vii. p. 355.) to be without this acid. Whatever description of casks are used, they should previously be rendered as clean and sweet as possible, well rubbed with salt, and the cavity between the bottom and sides filled in with melted butter.

7028. *An excellent composition for preserving butter* may be made, by reducing into a fine powder, and carefully mixing together, sugar and nitre, of each one part, and two parts of the best common salt. Moir to each pound weight of salt adds four ounces of raw sugar. Of this composition, one ounce should be thoroughly mixed with every sixteen ounces of butter, as soon as the latter has been freed from the milk; and the butter must be immediately put into the firkin, being pressed so close as to leave no air-holes, or any kind of cavities, within it. The surface must be smoothed; and, if a day or two be expected to elapse before more can be added, the vessel must be closely covered up with a piece of clean linen, upon which should be laid a piece of wetted parchment, or (if this be not procurable) with a piece of fine linen dipped in melted butter, that is exactly fitted to the edges of the vessel all round, so as to exclude the air as much as possible. When more butter is to be added, these coverings are to be removed; the butter is to be applied close upon the former layer, pressing it down, and smoothing it as before, till the vessel be full. The two covers are then to be spread over it with the greatest care; and a little melted butter is to be poured all round the edges, so as to fill up every part, and effectually to exclude the air. A little salt may then be strewed over the whole, and the cover be firmly fixed down. Butter thus cured does not taste well till it has stood at least a fortnight after it has been salted; but after that period it acquires a rich marrowy taste, and will continue perfectly sweet in this climate for many years. As, however, its quality is liable to be impaired by being improperly treated while it is using, it will be necessary, when the firkin is opened, first to pare off a small portion of the whole surface, especially near the edges, in case the air should, by any accident, not have been entirely excluded. If it is to be quickly consumed, it may be taken up as it is wanted, without any other precaution than that of keeping it carefully covered up; but, on the contrary, if it is to be used very slowly, and if the person employed to take it up be not very careful in closing it up each time with the covers, the part which is thus exposed to the air will be liable to contract a small degree of rancidity. To prevent the occurrence of this inconvenience, when the vessel is opened, a strong brine of common salt (strong enough to float an egg) should be poured, when cold, upon the surface of the butter; and although the quality of the latter will be slightly injured by the action of the water upon it, yet that is a much less evil than the slightest rancidity would occasion.

7029. *Butter casks*. The following is the plan adopted by Moir:—"Cut the wood into deals of the lengths wanted; have a boiler of a square form, the length of the wood, full of water; put in the wood with a weight or pressure, to keep it immersed in the water, and have a wooden cover on the boiler, as it must be done by close evaporation. When thus boiled for *four hours*, the whole of the pyroligneous acid will be extracted. The wood is then dried for use. It becomes closer and more condensed, from the fibres being contracted. By this method, while the wood continues hot, it can be easily brought to any shape, and used for various purposes; and this is the only mode by which barrels for salted butter should be made. (*Highl. Soc. Trans.* vol. vii. p. 356.)

7030. *When butter is to be exposed to the heat of a warm climate*, it should be purified by melting before it is salted and packed up. For this purpose, let it be put into a proper vessel, and this be immersed into another containing water. Let the water be heated till the butter be thoroughly melted: let it continue in this state for some time, when the impure parts will subside, leaving at the top a perfectly pure transparent oil. This, when it cools, will become opaque, and assume a colour nearly resembling that of the original butter, being only somewhat paler, and of a firmer consistence. When this refined butter is become a little stiff, but while it is still somewhat soft, the pure part must be separated from the dregs, and be salted and packed up in the same manner as other butter; it will continue sweet much longer in hot climates, as it retains the salt better than in its original state. It may also be preserved sweet, without salt, by adding to it a certain portion of fine honey, perhaps one ounce to a pound of butter, and mixing them together thoroughly, so that they may be perfectly incorporated. A mixture of this sort has a sweet pleasant taste, and will keep for years without becoming rancid: there is no doubt, therefore, but that butter might thus be preserved in long voyages without spoiling.

7031. *As winter-made butter* is mostly pale or white, and, at the same time, of a poorer quality than that made during the summer months, the idea of excellence has been associated with the yellow colour; hence, various articles have been employed in order to impart this colour. Those most generally used, and certainly the most wholesome, are the juice of the carrot, and of the flowers of the marigold, carefully expressed, and strained through a linen cloth. A small quantity of this juice (and the requisite proportion is soon ascertained by experience) is diluted with a little cream, and this mixture is added to the rest of the cream when put into the churn. So small a quantity of the colouring matter unites with the butter, that it never imparts to it any particular taste.

7052. *The butter most esteemed in London* is that of Epping and Cambridge: the cows which produce the former feed during summer in the shrubby pastures of Epping forest, and the leaves of the trees and numerous wild plants which there abound are supposed to improve the flavour of the butter. It is brought to market in rolls from one to two feet long, weighing a pound each. The Cambridgeshire butter is produced from the milk of cows that feed one part of the year on chalky uplands, and the other in rich meadows or fens; it is made up into long rolls like the Epping butter, and generally salted, not cured, before brought to market. By washing it, and working the salt out of it, the London cheesemongers often sell it at a high price for fresh Epping butter.

7053. *The Suffolk and Yorkshire butter* is often sold for that of Cambridgeshire, to which it is little inferior. The butter of Somersetshire is thought to equal that of Epping; it is brought

to market in dishes, containing half a pound each, out of which it is taken, washed, and put into different forms by the buttermen of Bath and Bristol. The butter of Gloucestershire and of Oxfordshire is very good; it is made up in half-pound packs or prints, packed up in square baskets, and sent to the London market by waggon.

7054. *The butter of the mountains* of Wales and Scotland, and the moors, commons, and heaths of England, is of excellent quality, when it is properly managed; and though not equal in quantity, it often is confessedly superior to that produced from the richest meadows. Bad butter is more frequently the result of mismanagement, want of cleanliness, and inattention, than of any other cause. Ireland would produce the finest butter in the empire, were it not for the intolerably filthy state of their cows, and the want of cleanliness in their dairies.

7035. *In packing fresh butter*, or butter salted only for immediate use, the leaves of cabbage, white beet, or of the garden orache (*Atriplex hortensis*) are to be preferred. The bottom of the basket should be bedded with a thick cloth, folded two or three times; then a thin gauze, dipped in cold water, spread over it, on which the prints or rolls of butter are to be placed, each with one or more leaves beneath, and smaller ones over it. The lowermost layer being adjusted, fold half of the gauze cloth over it, put in another layer in the same way, and then cover with the remainder of the gauze. The butter should be put into the basket, as well as taken from thence, without being touched.

7036. *Whey butter*, as its name implies, is butter made from the whey which is taken from the curd, after the milk is coagulated for the manufacture of cheese. It is chiefly made in those counties where cheese is manufactured, and where it forms no inconsiderable part of the profits of the dairy. In the county of Derby more butter is said to be made from whey than from the cream of milk, or from milk churned altogether.

7037. *Whey is divided into two sorts*, green and white, the former escaping readily from the curd, while the latter is freed from it by means of pressure. "There are different methods of extracting the whey. In some dairies the whole whey, when taken from the cheese-tub, is put into pails or other vessels, where it remains for about twenty-four hours; when it is creamed, and the whey is applied to the use of calves and pigs, which are said to thrive as well on it, after the cream has been taken from it, as before. The cream, when skimmed off the whey, is put into a brass pan and boiled, and afterwards set in pans or jars, where it remains till a sufficient quantity for a churning be procured, which, in large dairies, happens generally once, but sometimes twice, in the week." In Ayrshire whey is given to horses.

7038. *Butter forming an important article of commerce as well as food*, the legislature has passed various statutes respecting its package, weight, and sale. The principal of these are the 36th and 38th of Geo. III.

SECT. V. *Process of Cheese-making.*

7039. *The production of cheese* includes the making of rennet, the selection of a colouring matter, the setting of the curd, and the management of the cheese in the press.

7040. *The milk fresh drawn* from the cow is to be immediately strained into the dishes or shallow troughs, if these are used, in order to promote cooling, as the surest guard against fermentation. The same object may be attained by repeatedly drawing off the milk from the coolers, and pouring it back again.

7041. *To understand what rennet is, and its uses*, it is necessary to premise that milk is no sooner taken into the stomach, than it becomes curdled by the operation of the gastric juice, as every one who has seen much of infant children must have observed. What is called rennet is nothing more than the stomach of an animal in which the gastric juices are preserved by means of salt.

7042. *The application of any kind of acid* will cause milk to coagulate, as well as the infusion of several plants, as ladies' bedstraw (*Galium verum*), butter-wort (*Pinguicula vulgaris*), and others. With the former plant the Jews coagulate the milk for all their cheese; the Mosaic law prohibiting them to mingle meat with milk, and rennet they consider as meat.

7043. *The maw or stomach of ruminating animals*, which admit of obtaining the gastric juice in a less mixed state than those of others, and chiefly of a young calf that has been killed before the digestion is perfected, is almost universally preferred as rennet. This bag or maw is cleaned and salted in different ways in different districts; but the following method, described by Marshal in his *Rural Economy of Norfolk*, is considered as one of the best. "Take a calf's bag, maw, or stomach; and having taken out the curd contained therein, wash it clean, and salt it thoroughly inside and out, leaving a white coat of salt over every part of it. Put it into an earthen jar, or other vessel, and let it stand three or four days; in which time it will have formed the salt and its own natural juice into a pickle. Take it out of the jar, and hang it up for two or three days, to let the pickle drain from it. Re-salt it, place it again in a jar, cover it tight down with a paper pierced with a large pin, and in this state let it remain till wanted for use. In this state it ought to be kept twelve months; it may, however, in case of necessity, be used a few days after it has received a second salting; but it will not be so strong as if kept a longer time."

7044. *In order to prepare this rennet for use*, Marshal gives the following directions:—"Take a handful of the leaves of sweet-briar, the same quantity of the leaves of the dog-rose, and the like quantity of bramble leaves; boil them in a gallon of water, with three or four handfuls of salt, about a quarter of an hour; strain off the liquor, and, having let it stand till perfectly cool, put it into an earthen vessel, and add to it the maw, prepared as above. To this is added a good sound lemon, stuck round with about a quarter of an ounce of cloves, which give the rennet an agreeable flavour."

7045. *The strength of the rennet thus prepared* will increase in proportion to the length of time during which the bag remains in the liquor; the quantity to be used for the purpose of coagulating milk can, therefore, be ascertained only by daily use and occupation. In general, however, it may be stated, upon the average, that somewhat less than half a pint of wine measure will suffice for fifty gallons of milk, for which quantity, in Gloucestershire, the practice is to employ about one third of a pint. Throughout the whole process of preparing and preserving rennet, too much attention cannot be given to its clean-

liness and sweetness; for if it be kept too long, so as to become foul or tainted, the cheese will invariably become affected by it, and will prove unfit for use.

7046. *In Holland* a small quantity of the muriatic acid is used instead of rennet; and it is the use of this article which gives to the Dutch cheese that pungent relish which induces so many persons to prefer it.

7047. *Colouring matter.* As cheese in its native state, that is, such as is well manufactured, being put together in proper time, the milk being of a proper degree of warmth, and in all other respects properly pressed, salted, and dried, is uniformly of a bright yellow cast, the idea of excellence is generally attached to cheese of such a colour. Hence it has become necessary for the dairyman, who would dispose of his cheese to advantage, to impart a light yellow orange colour to it by artificial means.

7048. *Turmeric, marigolds, hawthorn buds,* and other vegetables, were formerly employed for this purpose; but these have long since been rejected for the *Spanish Arnotto*, which is unquestionably the best ingredient of the kind that can be used for the colouring of cheese. It is a preparation of the *roucon* or arnotto tree (*Bixa Orellana* Lin., fig. 166.), which is a native of America. The red pulp, that covers the seeds of this tree, is suspended in hot water, and allowed to subside, and when dry, is formed into cakes or balls, which are further set aside, until they become completely dry and firm. One ounce of this substance, when genuine, will be sufficient to colour an hundred weight of cheese; and this is the common allowance in the county of Gloucester; in Cheshire, the weight of a guinea and a half is considered to be sufficient for a cheese of sixty pounds weight. The usual mode of applying the arnotto is to dip a piece, of the requisite size and weight, in a bowl of milk, and rub it on a smooth stone until the milk assume a deep red colour. This infusion is to be added to the milk, of which cheese is intended to be made, in such a quantity as will impart to the whole a bright orange colour, which will become the deeper in proportion to the age of the cheese. The mixing of the arnotto in no respect affects either its taste or smell.

7049. *In the county of Cheshire,* however, a somewhat different practice obtains. There, when the colouring matter is wanted, it is usual to tie up as much of the substance as may be deemed sufficient in a linen rag; putting it into half a pint of warm water, to let it stand over night. In the morning, immediately before the milk is coagulated, the whole of this infusion is mixed with it in the cheese-tub, and the rag is dipped in the milk, and rubbed on the palm of the hand, until all the colouring matter is completely extracted. A more simple method is directed by Parkinson: — “Take,” says he, “a piece about the size of a hazel nut, put it into a pint of milk the night before you intend to make cheese, and it will dissolve. Add it to the milk at the time the rennet is put in. The quantity will suffice to colour a cheese of twenty pounds weight.” (*Parkinson on Live Stock*, vol. i. p. 62.)

7050. *Setting the curd.* The proper season for making cheese is from the beginning of May till the close of September, or in favourable seasons till the middle of October. Very good cheese, however, may be made in winter, provided the cows be well fed. A certain elevation of temperature is requisite to the coagulation of milk, and it may naturally be supposed to be nearly that of the stomachs of milk-taking animals. Marshal is of opinion that from 85 to 90 degrees of heat, and two hours of time, are the fittest for coagulation.

7051. *Climate, season, weather, and pasture* may require that these limits should sometimes be violated. Milk produced from poor clays will require to be coagulated at a higher temperature than that which is procured from rich pastures. In some dairies the milk is heated to the proper temperature; but the most approved practice is to mix boiling water in such a proportion as shall render the milk of a proper degree of heat to receive the rennet; this the thermometer should be used to determine. In hot weather the milk in the cows' udders is liable to become very much agitated by their running about, or being driven to too great a distance: so that if rennet be put to it in this state, the curd, instead of coming in one or two hours, will require three, four, or five hours, and will be so spongy, tough, and in every respect so imperfect, as to be scarcely capable of being confined in the press or vat; and when released from the press, it will heave or split, and be good for little. Whenever, therefore, cows are discovered to be in this state, which perhaps can scarcely be avoided during very hot weather, where cows are pastured abroad, in unsheltered grounds, or where water is not within their reach; it will be advisable to add some cold fresh spring water to the milk as soon as it is brought into the dairy. The quantity to be mixed, in order to impart the proper degree of heat, can in this case only be regulated by experience and the use of the thermometer. The effect of the water thus added will, in both cases, be to make the rennet take effect much sooner, and consequently to accelerate the coagulation of the milk.

7052. *The proportion of rennet and time requisite for coagulation* have been already mentioned (7045. 7050.): too much rennet ought not to be put in, otherwise the cheese will be ready to heave, as well as become rank and strong; the same effects will also be produced if the rennet be made with bad or foul materials, or if it be too strong to operate in the given time (two hours). During the process, the milk ought to be covered so as not to lose more than five or seven degrees of its original heat. One or two handfuls of salt added previously to mixing the rennet will promote coagulation. Some put in a bowl, which is an absurd ancient custom, and injurious rather than useful.

7053. *When the coagulation has taken place,* the curd is broken or cut with a cheese-knife, which causes the whey to rise through the incisions, and the curd sinks with more ease. After a short time the cutting is repeated, still more freely than before; and is continued until the curd is reduced to small uniform particles. This operation will require about three quarters of an hour: the cheese-tub is again covered with a cloth, and is allowed to remain for the same time. When the curd has sunk to the bottom of the vessel, the whey is taken off by the hand, or by means of a skimming-dish; another quarter of an hour should now be allowed for the curd to settle, drain, and become solid, before it is broken into the vat, as it prevents the fat from being squeezed out through the fingers, and of course contributes to improve the quality of the cheese. Sometimes, in addition to the skimming-dish, a semicircular board and weight, adapted to the size of the tub, are employed. The curd is again cut as before, in order to promote the free separation of the whey, and pressure is again applied till it be wholly drawn off. Great attention is requisite in conducting this part of the business; and if any particles of slip curd should be seen floating in the whey, it ought to be carefully laded off with the whey; as it will not incorporate with the solid curd, but dissolving in the cheese, causes whey-springs, as already mentioned, and materially impairs its soundness. If the whey be of a green colour, when loaded or pressed out, it is a certain criterion that the curd has been properly formed: but if it be of a white colour, it is equally certain that the coagulation is imperfect, the cheese will be sweet, and of little value, and much valuable caseous matter will be completely thrown away. In the counties of Norfolk and Suffolk, the cheese manufacturers have recourse to a somewhat different method for extracting the whey, which is worthy of notice: when they think the milk sufficiently coagulated, they lay a strainer in a basket made for the purpose; into which they put the curd, and suffer it to remain there for some time to drain, before they break the curd. When the curd is sufficiently drained, it is put into two or three separate vessels, and is broken with the hand as small as

possible. During this part of the process salt is scattered over the curd, and intimately mixed with it; the proportion, however, has not been correctly ascertained, and is regulated by experience.

7054. *Management in the press.* The breaking and salting completed, a cloth is spread over the cheese vat, and the broken curd being packed into it, and covered up with the cloth, a smooth round board is laid over the vat, which is usually filled to the height of one inch above the brim, to prevent the curd from shrinking below its sides, when the whey is squeezed out.

7055. *The whole is then put into a press* for two hours, and as it is of the utmost importance that every drop of whey should be expressed, skewers are thrust into the cheese through the holes in the lower part of the vat to facilitate its escape. The two hours expired, the cheese is taken out and put into a vessel of warm or hot whey for an hour or two, in order to harden its skin. On taking the cheese out of the whey it is wiped dry, and when it has become cool, is wiped in a clean dry cloth, of a finer texture, and again submitted to the press for six or eight hours. The cheese is now turned a second time, and is taken to the salting room, where it is rubbed on each side with salt; after which it is wrapped in another dry cloth, of a finer texture than either of the preceding cloths, and is again pressed for twelve or fourteen hours; if any edges project these are paired off, and the cheese being laid upon a dry board, is turned every day. In the salting-room cheese should be kept warm until it has had a sweat, or has become regularly dry and somewhat stiff; as it is warmth that ripens cheese, improves its colour, and causes it when cut to have a flaky appearance, which is the surest sign of superior excellence.

7056. *Management in the cheese-room.* After the processes of salting and drying are completed, the cheeses are deposited in the cheese-room or loft, which should be airy and dry; but on no account should hard and soft cheeses be placed in the same room, for the dampness or moisture arising from the latter will cause the hard cheese to chill, become thick coated, and often spotted. Throughout the whole process of cheese-making, the minutest attention will be requisite; for if the whey be imperfectly expressed, or the rennet be impure, or the cheese be not sufficiently salted, it will become rank and pungent. For this defect there is no remedy. The imperfect separation of the whey will cause cheese to heave or swell, as well as to run out at the sides.

7057. *In order to prevent as well as to stop this heaving*, the cheese must be laid in a moderately cool and dry place, and be turned regularly every day. If the heaving be very considerable, the cheese must be pricked on both sides in several places, particularly where it is most elevated, by thrusting a skewer into it: by this pricking, though the heaving will not be altogether prevented, a passage will be given to the confined air, the heaving or swelling will consequently be considerably reduced, and the cavities of the cheese will be less offensive to the eye. Another remedy for *heaving* in cheese consist in applying a composition of nitre and bole armoniac, which is vended in the shops under the name of *cheese-powder*. It is prepared by mixing one pound of saltpetre with half an ounce of bole armoniac thoroughly together, and reducing them to a very fine powder. About a quarter of an ounce of this is to be rubbed on a cheese, when put a second and third time into the press, half on each side of the cheese at two different meals, before the salt is rubbed on, that the cheese may be penetrated with it. This preparation is very binding, and sometimes proves serviceable, but the nitre is apt to impart an acid taste; and if too much be applied, and the cheese should be exposed to too great heat, the quantity of air already confined in it will be increased by fermentation, and the cheese will swell much more than it would if no powder had been rubbed in. The greatest care, therefore, will be necessary whenever this remedy is adopted.

7058. *Hard and spoiled cheese* may be restored in the following manner: take four ounces of pearlsh, and pour sweet white wine over it, until the mixture ceases to effervesce. Filter the solution, dip into it clean linen cloths, cover the cheese with them, and put the whole into a cool place, or dry cellar. Repeat this process every day, at the same time turning the cheese, and, if necessary, continue it for several weeks. Thus the hardest and most insipid cheese, it is affirmed, has frequently recovered its former flavour.

SECT. VI. *Catalogue of the different Sorts of Cheeses and other Preparations made from Milk.*

7059. *Of cheeses*, we shall first enumerate the British sorts, and next those peculiar to foreign countries: the description of each will be such as to enable any ingenious dairymaster to imitate them.

7060. *The brick-bat cheese* is so named from the form of the mould; it is formed of new milk and cream in the proportion of two gallons of the former to a quart of the latter. It is principally made in Wiltshire, in the month of September, and should not be cut until it is twelve months old.

7061. *Cheddar cheese*, so named from the vale of that name in Somersetshire, where it is exclusively made. It is made in cheeses about thirty pounds each, which have a spongy appearance, and the eyes are filled with a limpid and rich, but not rancid oil.

7062. *Cheshire cheese* is in universal esteem; it is made from the whole of the milk and cream, the morning's milk being mixed with that of the preceding evening, previously warmed. The general weight is sixty pounds each cheese.

7063. *Dunlop cheese* (so called from its having been first brought to the Glasgow market by a carrier who lived in the parish of Dunlop, in Ayrshire,) has been made in the district of Cunningham in Ayrshire, from time immemorial. The quality of this cheese has certainly not been equalled in any other part of Scotland, and scarcely surpassed in England. According to Aiton, it is "milder in its taste, and fatter, than any English cheese whatever." The following directions are from this author's *Dairy Husbandry*.

7064. *When as many cows are kept on one farm as that their milk will form a cheese of any tolerable size every time they are milked (twice a day)*, the milk, as it comes from the cows, is passed through a sieve (provincially termed a *milsey*) to remove impurities into a boyn (vat), and when the whole is collected, it is formed into curd by a mixture of rennet. As milk requires to be coagulated as nearly as possible at the temperature of animal heat, and as it must cool considerably during the operation of milking from several cows, and in passing through the sieve, it is necessary for those who set their curd in the natural heat to make up some part of that which is lost, by mixing a quantity of hot water into the curd vat.

7065. *When the cows on a farm are not so numerous as to yield milk sufficient to make a cheese every time they are milked*, the milk is stored about six or eight inches deep in the coolers that

have been described, and placed in the milk-house till as much is collected as will form a cheese of a proper size. When the cheese is to be made, the cream is skimmed from the milk in the coolers, and without being heated is, with the milk that is drawn from the cows at the time, passed through the sieve into the curd-vat; and the cold milk from which the cream has been taken is heated, so as to raise the temperature of the whole mass to near blood heat; and the whole is coagulated by means of rennet carefully mixed with the milk. The cream is put into the curd-vat, that its oily parts may not be melted, and the skimmed milk is heated as much as to raise the whole to near animal heat. The utmost care is always taken to keep the milk in all stages of the operation free, not only from every admixture or impurity, but also from being hurt by foul air arising from acidity in any milky substance, putrid water, the

stench of the byre, dunghill, or any other substance; and likewise to prevent the milk from becoming sour, which when it happens greatly injures the cheese.

7066. *The temperature* at which the milk is kept from the time it is drawn from the cows till it is formed into cheese, ready to be put up to dry, is a matter of great importance, and should be carefully attended to. The milk, when taken from the cow, ought to be as soon as possible cooled to below 55°, or between that and 50° on Fahrenheit's scale: to cool it speedily, and to facilitate the separation or rising of the cream, a small quantity of clean cold water is generally mixed with the milk in each cooler; and when the stone or iron coolers that have been described are used, the milk will cool in them much sooner than in the wooden dishes formerly in use. If the milk is kept warmer than 55° of temperature, it will not properly cast up the cream, which it is thought necessary it should do even when the whole is to be formed into cheese, and the milk will soon become sour, and acquire a bad taste, if it is not brought to near that degree of temperature; but if it gets into a lower temperature than about 50° the milk acquires an insipid and unpleasant taste, of which it cannot be again divested; it does not coagulate nearly so well, and the cheese made from it is soft and inadhesive, the curd difficult to be separated from the whey, and the milk and cheese are never well tasted.

7067. *Milk ought to be coagulated at nearly its natural heat when drawn from the cow*, or from 90 to 95 degrees of temperature, and for that purpose a thermometer ought to be used in the milk-house. If coagulated much warmer, the curd is tough, harsh, and too adhesive; much of the butteraceous matter is melted, and goes off with the whey, and the cheese becomes hard, dry, tough, and tasteless; and if the milk is too cold when coagulated, the curd is soft, does not part with the serum, and the cheese continues to be so soft that it is with difficulty that it can be kept together. Even when the utmost pains are taken to extract the whey, and to give it solidity and firmness, putrifying holes, which in dairy language are termed "eyes," whey-drops, or springs, frequently break out on the cheese; and it is always soft, tough, and of an insipid taste.

7068. *Whenever the milk is completely coagulated*, the curd is broken, in order to let the serum or whey be separated and taken off. Some break the curd slightly at first, by making cross-scores with a knife or a thin piece of wood, at about one or two inches distance, and intersecting each other at right angles; and these are renewed still more closely after some of the whey has been discharged. But others break the whole curd rather more minutely at once with the skimming dish, the hand, or any thing convenient; but they do not break or churn it, as is done in England. When this last method is pursued, the whey comes off rather too white and rich, or with too much of the cream at first; but it comes most copiously, and it is only for a few minutes at first that the whey is too rich. By the method first mentioned, the whey does not come off so copiously nor so rich at first, as when the curd is more minutely broken.

7069. *When the coagulum has been formed at a proper temperature*, neither too cold nor too hot, breaking the curd minutely, but gently and softly, seems to be most proper: for though the whey is a little too white at first, that is soon over; it comes off abundantly pure in a few minutes after; and it flows more copiously than when the curd is slightly broken at first. The advantage of a speedy discharge of the whey, as it saves time, and prevents the curd from becoming too cold and acquiring any bad taste or flavour (which it often contracts when neglected at that stage of the operation), is an ample compensation for any small quantity of the oily parts that may come off at first breaking.

7070. *But if the milk has been either too cold or too hot when coagulated*, I would recommend breaking the curd as slightly and easily as possible at first: if too hot, the whey naturally comes off copiously, but it is too white, and contains a portion of the butteraceous matter in the curd; and the complete breaking at first adds to that evil, and brings off still more of the oily substance from the curd, to the impoverishment of the cheese. Such quick agitation too tends to render the warm curd still more tough and adhesive. When the milk has been too cold at the time the curd was formed, it will be by far too soft to be minutely broken at first; and when that is done, some of the curd will come off with the whey: in that case the curd should be dealt with as gently as possible.

7071. *After the curd has been broken*, the whey ought to be taken off as speedily as it can be done, and with as little further breaking or hauling the curd as possible. It is still necessary, however, to turn it up, cut it with a knife, or break it gently with the hand, in order to facilitate the separation of the whey from the curd.

7072. *When the curd has consolidated a little*, it is cut with the cheese knife, gently at first, and more minutely as it hardens, so as to bring off the whey. When the whey has been mostly extracted, the curd is taken up from the curd-boyn, and being cut into pieces of about two inches in thickness, it is placed into a sort of vat or sieve with many holes; a lid is placed over it, and a slight pressure, say from three to four stones avoirdupoise; and the curd is turned up and cut small every ten or fifteen minutes, and occasionally pressed with the hand so long as it continues to discharge serum. When no more whey can be drawn off by these means, the curd is cut as small as possible with the knife, the proper quantity of salt minutely mixed into it in the curd-boyn, and placed in the chessart within a shift of thin canvass, and put under the press.

7081. *Gloucester cheese* is in very considerable demand from its mild taste, which suits most palates, especially those of the young and of simple habits: there are two kinds, double and single, the first made from the milk and cream, and the latter with the milk deprived of about half the cream: the latter are of course the least valuable; but as they may be often mistaken for the former, upright dairymen, Marshal observes, impress a heart-shaped stamp upon them to distinguish them from the former. They are made of various sizes, from twenty to seventy, or even eighty pounds weight, but generally from fifty to sixty pounds.

7082. *Green, or sage-cheese*, is made by steeping over night in a proper quantity of milk, two parts of sage, one part of marigold leaves, and a little parsley, after they have been bruised. On the following morning, the *greened* milk is strained off, and mixed with about one third of the whole quantity intended to be run or coagulated. The green and white milks are run separately, the two curds being kept apart until they be ready for vating: these may be mixed, either evenly and intimately, or irregularly and fancifully, according to the pleasure of the manufacturer. The management is the same as for common cheese. Green cheeses are made in the vale of Gloucester, as also in Wiltshire.

7073. *All these operations ought to be carried on with the least possible delay*, and yet without precipitation. The sooner the whey is removed after the coagulation of the milk, so much the better. But if the curd is soft, from being set too cold, it requires more time, and to be more gently dealt with; as otherwise much of the curd and of the fat would go off with the whey. And when the curd has been formed too hot, the same caution is necessary. Precipitation, or handling the curd too roughly, would add to its toughness, and expel still more of the oily matter: and, as has been already mentioned, hot water or whey should be put on the curd when it is soft and cold; and cold water put on when the curd is set too hot.

7074. *After the cheese is put into the press* it remains for the first time about an hour, or less than two hours, till it is taken out, turned upside down in the cheese-vat, and a new cloth put round it every four or six hours till the cheese is completed; which is generally done in the course of a day and a half, two, or at most three days after it was first put under the press.

7075. *The process of salting* is very differently conducted in the Scotch dairies from what it is in England. In Scotland, the salt is minutely mixed into the curd after it has been rendered as dry as possible, and cut very small by means of the cheese-knife, as has been already mentioned. This seems to answer the purpose just as well as the mode pursued in England, to be afterwards described, which is far more troublesome, and must be much more expensive, both in waste of salt, in apparatus, and in labour. The greatest defect I can perceive in the salting in Scotland is, that the salt is generally applied to the cheese merely by guess, whereas it ought to be more carefully regulated. Half an ounce of salt to every English pound of cheese, or at most thirteen ounces to twenty-four pounds English, is a sufficient quantity. Too much salt renders the cheese dry, tough, and hard; and if a sufficient quantity is not given, the cheese will become putrid.

7076. *Cheeses made in Scotland* are never washed or greased with butter, as is done in Cheshire. The Scots cheeses contain the grease internally, and not on the outside.

7077. *When the cheeses in Scotland are ultimately taken from the press*, and which is generally after two or three days from the time they were first placed under it, they are exposed for a week, to the drought and heat of the farmer's kitchen; not to excite sweating, but merely to dry them a little before they are placed in the store, where a small portion of heat or drought is admitted. While they remain in the kitchen, they are turned over three or four times every day; and whenever they begin to harden a little on the outside, they are laid up on the shelves of the store, where they are turned over once every day or two days for a week or so, till they are dry; and twice every week afterwards.

7078. *The store-houses for cheese in Scotland* are in proportion to the size of the dairy, generally a small place adjoining the milk-house, or at the end of the barn or other buildings, where racks are placed, with as many shelves as hold the cheeses made for the season. Where no particular place is prepared, the racks are placed in the barn, which is generally empty during summer; or some lay the cheeses on the floor of a garret over some part of their dwelling-house.

7079. *Wherever the cheeses are stored*, they are not sweated or put into a warm place, but kept cool, in a place in a medium state between damp and dry, without the sun being allowed to shine on them, or yet a great current of air admitted. Too much air, or the rays of the sun, would dry the cheeses too fast, diminish their weight, and make them crack; and heat would make them sweat or perspire, which extracts the fat, and tends to induce heaving. But when they are kept in a temperature nearly similar to that of a barn, the doors of which are not much open, and but a moderate current of air admitted, the cheeses are kept in proper shape, neither so dry as to rend their skins, nor so damp as to render them mouldy on the outside, and no partial fermentation is excited, but the cheese preserved sound and good.

7080. *On the comparative taste* of the Scots and English cheese it is difficult to offer any opinion: there is not only such a diversity in the taste, not only of cheeses made in different dairies, at the different seasons of the year, stages of the cow's milk, state of the weather, and many slighter accidents; but there is also such a diversity in the taste of the consumers, that it is impossible to speak with any degree of precision as to the standard of perfection of the taste of cheese. The taste of mankind as to cheese varies so much that it is found necessary to bring forward both Scots and English cheeses, of different sorts and ages, some sound and others unsound or putrid, and to ask each lady and gentleman at table which they prefer. Do you eat Scots or English? coloured or white? old or new? sound or unsound? &c. The taste of some is so vitiated, as to like best the putrid parts, which abound with animalcula, and touch the olfactory nerves before they reach the mouth; others prefer that which is sound. The Scots cheese is generally less smart, acrid, and pungent in the taste than the English cheese. It is not so high flavoured, owing probably to the inferiority of the pasture and climate, or partly to the mode of manufacturing it. It is milder in the taste, and generally fatter, than the English cheese. A small morsel of English cheese after a good dinner may be better felt in the mouth than the softer and milder cheese of Scotland; but if any considerable quantity is to be eaten, the latter will not be felt so hot and heavy in the stomach as the same quantity of English cheese.

7083. *Lincolnshire cheese* is made by adding the cream of one meal's milk to that which comes immediately from the cow; it is pressed gently two or three times, and is turned for a few days previously to being used. It is chiefly made in spring, but the richest is that made in autumn. It will not keep above three months.

7084. *Norfolk cheese* is made from the whole of the milk and cream; the size is from thirty to fifty pounds; it is generally coloured yellow, and is reckoned a good keeping cheese.

7085. *Soft, or slip-coat cheese*, is made from new milk hot from the cow, and the afterings; and what is required to make one pound of butter, will, in general, make one pound of cheese: this is a small soft rich cheese, which must be used immediately.

7086. *Stilton cheese*, which, from its peculiar richness and flavour, has been called the Parmesan of England, is made in the following manner:—The night's cream is put to the morning's milk with the rennet; when the curd is come, it is not broken as is usual with other cheese, but is taken out whole, and put into a sieve to drain gradually; while draining, it is gently pressed till it becomes firm and dry, when it is placed in a vat, a box made exactly to fit it; as it is so extremely rich, that without this precaution it is apt to bulge out, and break asunder. It is afterwards kept on dry boards, and turned daily, with cloth binders round it, which are tightened as occasion requires. After being taken out of the vat, the cheese is closely bound with cloth till it acquires sufficient firmness to support itself: when these cloths are removed, each cheese is brushed once every day for two or three months, and if the weather be moist, twice every day; the tops and bottoms are treated in a similar manner daily before the cloths are taken off. Stilton cheese derives its name from the town where it is almost exclusively sold; it is made principally in Leicestershire, though there are also many who manufacture it in the counties of Huntingdon, Rutland, and Northampton. Sometimes the cheeses are made in a net, resembling a cabbage net, which gives them the form of an acorn; but these are neither so good nor so richly flavoured as those made in vats, having a thicker coat, and being deficient in that mellowness which causes them to be in such general request. (*Bath Papers*, vol. iii. p. 152, 153.) Stilton cheese is not reckoned to be sufficiently mellow for cutting until it is two years old, and it is not saleable unless it is decayed, blue, and moist. In order to mature them the more rapidly, it is a frequent practice to place the cheeses in buckets, which are covered over with horse-dung. Wine is also reputed to be added to the curd, in order to accelerate the ripening of the cheese.

7087. *Cottenham cheese*, from the town of that name in Cambridgeshire, is a thicker kind of cream cheese than the Stilton: its superior delicacy and flavour are attributed to the fragrant nature of the herbage on the commons on which the cows are pastured, and, according to Professor Martyn, to the prevalence of *Poa aquatica* and *pratensis*.

7088. *Suffolk, or skim cheese*, is made of skimmed milk; it forms a part of every ship's stores, not being so much affected by heat as richer cheese, nor so liable to decay in long voyages.

7089. *Wiltshire cheese* is made of new milk coagulated as it comes from the cow: sometimes a small quantity of skimmed milk is added. In some dairies it is manufactured in winter as well as summer; in the former case it is liable to become scurfy and white coated; the last of which defects is frequently concealed by a coat of red paint.

7090. *Of foreign cheeses*, the most common is the *Dutch cheese*; this is prepared much in the same manner as the Cheshire cheese, excepting that muriatic acid is used instead of rennet, which renders it pungent, and preserves it from mites; that of Gouda is preferred.

7091. *Parmesan cheese* (formaggio di grana, cheese used in a granular form,) is made in the Duchy of Parma, and in various places in Lombardy. It was formerly supposed to be made from the milk of goats, but it is merely a skim-milk cheese, the curd hardened by heat, well salted, pressed, and dried, long kept, and rich in flavour from the rich herbage of the meadows of the Po, where the cows are pastured.

7092. *The process*, according to Pryce, (*Bath Papers*, vol. vii.) is as follows:—The evening's milk, after having been skimmed in the morning, and standing till ten o'clock, and the morning's milk skimmed about two hours after it is drawn from the cow, are mixed together. The mixture is then suspended in a copper cauldron over a wooden fire (*fig. 35.*), and frequently stirred till it attains about 82° of Fahrenheit; the rennet is then put in, and the copper being removed from the fire, the coagulation quickly takes place, and the curd is afterwards worked with a stick till it is reduced to a small grain. The whey now occupies the surface, and a part of it being taken out, the cauldron is again turned over the fire, and its contents brought to nearly a boiling heat. A little saffron is now added to impart colour, the whole being all the while well stirred, and the superintendant examining it from time to time with his finger and thumb, to ascertain the exact moment when the curd shall have become sufficiently solid. When this is the case, the cauldron is removed from the fire, and the curd allowed to subside; three fourths of the whey is then drawn

off, water poured round the bottom of the cauldron outside to cool it, so as to admit of a cloth being passed below the curd, which is thus brought up and placed in a tub to clear. When drained, it is put into a wooden hoop, and about half a hundred weight laid on it for half an hour; the cloth is then removed, and the cheese being replaced in the hoop is laid on a shelf; here it remains for two or three days, at the end of which, it is sprinkled over with salt; this sprinkling is repeated every second day for about thirty days if it be summer, and for about forty or fifty-five days if it be winter, after which no further attention is required. The best Parmesan cheese is that which has been kept for three or four years, but none is ever carried to market for sale until it has been kept at least six months. A short account of a Parmesan cheese dairy, situated thirteen miles from Milan, is given in *Cadell's Journey in Carniola*, 8vo, 1818, and quoted in *Farm. Mag.* vol. xxi. p. 161. The process is there carried on in conformity with what is above stated.

7093. *Swiss cheese* is of several varieties, mostly of skimmed or partially skimmed milk, and manufactured like the Parmesan. Its varied and rich flavour is more owing to the herbage of the pastures than the mode of making; and some sorts, as the Gruyère (so called from the bailiwick of that name in the canton of Fribourg), are flavoured by the dried herb of *Melilotus officinalis* (*fig. 43.*) in powder. Gruyère cheeses weigh from forty to sixty pounds each, and are packed in casks containing ten cheeses each, and exported to the most distant countries. This cheese requires to be kept in a damp place, and should frequently be washed with white wine, to preserve it from the depredations of insects. Neufchâtel is celebrated for a very fine sort of cheese made there, which, in shape, resembles a wash-hand ball.

7094. *Westphalia cheese* is of the skim-milk kind, and of a different character from any of those hitherto described. The cream is allowed to remain on the milk till the latter is in a sub-acid state; it is then removed, and the milk placed near a fire spontaneously to coagulate. The curd is then put into a coarse bag, and loaded with ponderous stones to express the whey: in this dry state it is rubbed between the hands, and crumbled into an empty clean milk vat, where it remains from three to eight days, according as the cheese is intended to be strong or mild. During this part of the process, which is called mellowing, the curd undergoes the putrid fermentation, and acquires a coat or skin on the top, before it is taken out of the vessel, and kneaded into balls or cylinders, with the addition of a considerable portion of carraways, salt, and butter; or occasionally a small quantity of pounded pepper and cloves. When over-mellowed, a third part of fresh curds, likewise crumbled into small pieces, is superadded, to prevent or correct its putrid tendency. As the balls or cheeses do not exceed three or four ounces each in weight, they soon dry in the open air, and are then fit for use. When nearly dry they are sometimes, for the palate of epicures, suspended in a wood-fire chimney, in a net, for several weeks or months; and both their taste and flavour are said to be remarkably improved, whether kept in a dry air, or subjected to the action of smoke. This sort of cheese M. Hochheimer, who describes it, affirms to be preferable to the Dutch, Swiss, and even Parmesan cheese. It is sometimes to be had in London, but is not very common.

7095. *Blue milk cheese* is made in the neighbourhood of Edinburgh, by Mr. Johnston, of Hill House. It is similar to the Stilton, to which it is said to be not inferior. Mr. Johnston never puts his curd into a cheese press, but into a bag or net, in which it is suspended, and frequently shifted, till it is sufficiently dry and solid. The cheeses are small; about five or six pounds each.

7096. *Potato cheese* is a German manufacture, of which there are three sorts. One of the best is thus prepared:— Select mealy potatoes, and only half dress them in steam; for by bursting their flavour and efficacy are diminished. Peel them, and then grate or beat them into a fine pulp. To three parts of this mass add two parts of sweet curd, knead and mix them, and allow them to stand three days in warm, and four or five days in cold, weather; form into small pieces like the Westphalia cheeses, and dry in the same manner. A still better sort of potato cheese is formed of one part of potatoes and three of the curd of sheep's milk. This sort is said to exceed in taste the best cheese made in Holland, and to possess the additional advantage that it improves with age, and generates no vermin.

7097. *The preparations of milk*, which can neither be included under butter nor cheese, are various, and constitute a class of wholesome luxuries or rural drinks. We shall do little more than enumerate them, and refer for further details to the cookery books.

7098. *Curds and whey* is merely coagulated new milk stirred up, and the curd and whey eaten together, with or without sugar and salt.

7099. *Curds and cream*; here the whey is removed and cream substituted, with or without sugar. The milk coagulated is often previously skimmed.

7100. *Sour cream*; cream allowed to stand in a vat till it becomes sour, when it is eaten with fresh cream and sugar, or new milk and sugar, and is found delicious.

7101. *Corstorphin cream*, so named from a village of that name, two miles from Edinburgh, from which the latter city is supplied with it. The milk of three or four days is put together with the cream, till it begins to get sour and coagulated, when the whey is drawn off and fresh cream added. It is, therefore, simply *sour curd* and *fresh cream*. It is eaten with sugar as a supper dish, and in great repute in the north.

7102. *Devonshire cream* is a term applied in the county of that name, sometimes to sour curd, and sometimes to sour cream; in either case mixed with new milk or fresh cream, and eaten with sugar like the Corstorphin cream.

7103. *Devonshire scalded or clouted cream*. The milk is put into tin or earthen pans, holding about ten or twelve quarts each. The evening's meal is placed the following morning, and the morning's milk is placed in the afternoon, upon a broad iron plate heated by a small furnace, or otherwise over stoves, where, exposed to a gentle fire, they remain until after the whole body of cream is supposed to have formed upon the surface; which being gently removed by the edge of a spoon or ladle, small air bubbles will begin to rise that denote the approach of a boiling heat, when the pans must be removed from off the heated plate or stoves. The cream remains upon the milk in this state until quite cold, when it may be removed into a churn, or, as is more frequently the case, into an open vessel, and then moved by hand with a stick about a foot long, at the end of which is fixed a sort of peel from four to six inches in diameter, and with which about twelve pounds of butter may be separated from the buttermilk at a time. The butter in both cases being found to separate much more freely, and sooner to coagulate into a mass, than in the ordinary way, when churned from raw cream that may have been several days in gathering, and at the same time will answer a more valuable purpose in preserving, which should be first salted in the usual way, then placed in convenient-sized egg-shaped earthen crocks, and always kept covered with a pickle, made strong enough to float and buoy up about half out of the brine a new-laid egg. This cream, before churning, is the celebrated clouted cream of Devon. Although it would be reasonable to suppose that the scalding the milk must have occasioned the whole of the oily or unctuous matter to form on the surface, still experience shows that this is not the case, and that the scalded skim-milk is much richer and better for the purposes of suckling, and makes far better cheese than the raw skim-milk does. The ordinary produce of milk per day, for the first twenty weeks after calving, is three gallons, and is equal to the producing of one pound and a quarter of butter daily by the scalding process. The scald skim-milk is valued at one penny farthing per quart, either for cheese-making or feeding hogs. The sum of the trials procured to be made on the milk in several parts of this district gives an average of twelve pints of milk to ten ounces of butter (less than ten quarts to a pound of sixteen ounces). When cheese is to be made, great care is taken that the milk is not heated so far as to produce bubbles under the cream. (*Vancouver's Survey of Devon*, p. 214.)

7104. *Clotted cream*. The milk, when drawn from the cow, is suffered to remain in the coolers till it begins to get sour and the whole is coagulated. It is then stirred and the whey drawn off, or the cream (now in clots among the curd) and the curd removed.

7105. *Hatted kitt*. A gallon of sour buttermilk is put in the bottom of the milk-pail, and a quart or more of milk drawn from the cow into it by the milk-maid. The new warm milk, as it mixes with the acid of the sour milk, coagulates, and being lighter, rises to the top and forms a creamy scum or hat over the other; whence the name. This surface stratum is afterwards taken off and eaten with sugar.

7106. *Milk syllabub* is formed in a similar manner over a glass or two of wine, and the whole is then eaten with sugar. Both sorts may be formed by those who have no cow, by warming the sweet or new milk, and squirting it into the wine or sour milk.

7107. *Skim-milk* is milk from which the cream has been removed. When this has been done within twelve or fifteen hours from the time of milking, it is sweet and wholesome, and fit either for being heated or coagulated in order to make cheese, &c., or used as it is with other food; but if allowed to remain twenty or thirty hours, it becomes sour, coagulates spontaneously, the whey separates from the curd; and if it remain a certain period, generally three weeks longer, in a warm temperature, the vinous fermentation takes place, and a wine or a liquor, from which ardent spirit may be distilled, is produced.

7108. *Buttermilk* is that which remains in the churn after the butter has been taken off. When butter has been made from cream alone, it is seldom of much value; but where the whole milk has been churned, and no water poured in during the process, it is a very wholesome cooling beverage. Some prefer it when it has stood a few days and become sour. In England it is chiefly given to pigs; but in Ireland it forms a very common diluter to porridge, potatoes, oat cakes, peas cakes, and other food of the labouring classes, and especially of the farm servants. In the Orkney Islands and other northern parts of Britain, as well as in Ireland, buttermilk is sometimes kept till it undergoes the vinous fermentation, when it is used to procure intoxication.

7109. *Sour milk*, Aiton observes, requires considerable care in the manufacturing, and the use of the thermometer ought never to be omitted. "When the operation is carried on at a low temperature, the milk swells when agitated in the churn, appears of a white colour, throws up air bubbles, and makes, when agitated or churned, a rattling noise. But when it is in proper temperature the milk does not swell or rise in the churn, it is of a straw or cream colour, emits a much softer sound, and does not cast up air bubbles so plentifully as when colder. When milk is either overheated or churned too hastily, the butter is always soft and of a white colour. From two to three hours is a proper time for performing the operation of churning. In the manufacture of sour milk, and in every branch of dairy husbandry, the utmost attention to cleanliness is indispensably necessary. The milk must no doubt become sour, and even coagulate before it is churned; but if that souring is not natural, but brought on by any foulness in the vessels through which the milk passes, or by any sort of admixture, or even by the milk being kept in a damp place, in one too hot or too cold, or even by exposure to an impure atmosphere, the acidity will not be a natural one, nor the taste of the milk or butter agreeable, but acrid and unpalatable. Every vessel through which the milk passes must be as clean, and every part where it is kept before being churned must be as free from dampness, and every species of impurity or bad air, as if it were intended to keep the

milk long sweet for skim-milk cheese. Buttermilk is used more or less by the labouring classes in all parts of Scotland, and in particular in the city of Glasgow; on the authority of the secretary to the Board of Agriculture, it is adjudged to the pigs in England; but in the western counties of Scotland, as well as in Ireland, it is used to a vast extent as human food. It is used as drink, and is certainly far superior to the miserable table-beer generally drank in England. It serves as kitchen to pottage, bread, potatoes, &c.; and when a linen bag like a pillow-slip is filled with it, and hung up till the serum drop, and a small quantity of sweet cream is mixed with what remains in the bag, and a little sugar when the milk is too sour, it forms a dish that might be placed on the table of a peer of the realm.

7110. *The method of making butter and buttermilk* in Holland is somewhat different from the mode in the vicinity of Glasgow. After the milk is cold it is put into a pan or vat, and well stirred with a wooden spoon or ladle two or three times a day, to prevent the cream from separating from the milk; and this sort of stirring or partial churning is continued till the milk becomes so thick and clotted that the ladle or spoon stands erect in the milk: after which it is put into the churn, and beat or churned for one hour or so. Cold water is poured in, to help to collect the butter and separate the milk from it; after which the butter is washed in cold water. By this method the Hollanders imagine they obtain more butter from the milk than they can do any other way. They also say, that both the butter and buttermilk are better when made in that way than when churned as is done in England.

7111. *Whey*, when new and of a pale green colour, forms an agreeable beverage, and with oatmeal makes an excellent gruel or porridge. Left till it gets sour, it undergoes the vinous fermentation as readily as buttermilk; and man, who in every state of civilisation feels the necessity of occasionally dissipating the cares of his mind, when he cannot find tobacco, opium, malt liquors, or ardent spirit, has recourse to sour whey.

CHAP. VI.

The Sheep. — *Ovis Aries* L.; *Mammalia Pécora* L., and *Ruminàleæ* Cuv. *Brébis*, Fr.; *Schaf*, Ger.; *Oveja*, Span.; and *Pecora*, Ital.

7112. *The sheep* is an inhabitant of every part of the globe, from Iceland to the regions of the torrid zone. The varieties of form and clothing necessary to fit it for existing in so many climates are of course numerous. In most of these countries it is cultivated for its wool or flesh, and in many for both; but it is most cultivated in Europe, and especially in France, Spain, and Britain. In the latter country its culture has attained an astonishing degree of perfection. Besides the *O. Aries*, or common sheep, there are three other species; the *O. Ammon* or Siberian sheep, the Pudu or South American, and the *Strepsíceros* or Cretan sheep. By some these are considered mere varieties. The Cretan and Siberian are cultivated in Hungary and Siberia.

7113. *The common sheep in a wild state* prefer open plains, where they herd together in small flocks, and are in general active, swift, and easily frightened by dogs or men. When completely domesticated, the sheep appears as stupid as it is harmless. It is characterised by Buffon as one of the most timid, imbecile, and contemptible of quadrupeds. When sheep, however, have an extensive range of pasture, and are left in a considerable degree to depend on themselves for food and protection, they exhibit a more decided character. A ram has been seen in these circumstances to attack and beat off a large and formidable dog. Sheep display considerable sagacity in the selection of their food; and in the approach of storms they perceive the indications with accurate precision, and retire for shelter always to the spot which is best able to afford it. The sheep is more subject to disorders than any of the domesticated animals; glandiness, consumption, scab, dropsy, and worms frequently seizing upon and destroying it. That popularly called the rot is the most fatal, and is supposed to arise from the existence of animals called fluke worms, of the genus *Fasciola*, which inhabit the vessels of the liver. Other parasitic animals attack and injure them, as the hydatids within the skull, producing symptoms called sturdy, turnsick, staggers, &c. Frontal worms, deposited by the sheep fly, in some cases prove very injurious also.

7114. *Of all the domestic animals of Britain*, Brown observes, *sheep are of the greatest consequence*, both to the nation and to the farmer; because they can be reared in situations, and upon soils, where other animals would not live, and in general afford greater profit than can be obtained either from the rearing or feeding of cattle. The very fleece, shorn annually from their backs, is of itself a matter worthy of consideration, affording a partial return not to be obtained from any other kind of stock. Wool has long been a staple commodity of this island, giving bread to thousands who are employed in manufacturing it into innumerable articles for home consumption and foreign exportation. In every point of view, sheep husbandry deserves to be esteemed as a chief branch of rural economy, and claims the utmost attention of agriculturists. For many years back it has been studied with a degree of diligence and assiduity not inferior to its merits; and the result has been, that this branch of rural management has reached a degree of perfection favourable to those who exercised it, and highly advantageous to the public.

SECT. I. *Varieties of Sheep.*

7115. *The varieties of the O. Aries, or common sheep*, dispersed over the world are, according to Linnæus, the hornless, horned, blackfaced, Spanish, many-horned, African, Guinea, broad-tailed, fat-rumped, Bucharian, long-tailed, Cape, bearded, and morvant; to which some add the Siberian sheep, cultivated in Asia, Barbary, and Corsica, and the Cretan sheep, which inhabits the Grecian islands, Hungary, and Austria; by Linnæus considered as species.

7116. *The varieties of British sheep* are so numerous that at first sight it appears almost impossible to reduce them into any regular classes. They may, however, be divided in two ways: first, as to the length of their wool; and secondly, as to the presence or absence of horns. A third classification might be made after the place or districts in which such species are supposed to abound, to be in greatest perfection, or to have originated.

7117. *The long-woolled British sheep* are chiefly the * Teeswater, the * old and * new Leicester, the * Devonshire nots, Exmoor, and the Heath sheep.

7118. *The short-woolled sheep* are chiefly the Dorsetshire, * Hereford or Ryeland, the * South Down, the Norfolk, the * Cheviot, the * Shetland sheep, and the * Merinos.

7119. *The hornless breeds* are those in the above classes marked (*), the others have horns. These breeds, and their subvarieties, may be further arranged according as they are suited to arable or enclosed lands, and to open or mountainous districts.

7120. *The sheep best suited to arable land*, an eminent writer observes, in addition to such properties as are common in some degree to all the different breeds, must evidently be distinguished for their quietness and docility; habits which, though gradually acquired and established by means of careful treatment, are more obvious, and may be more certainly depended on in some breeds than in others. These properties are not only valuable for the sake of the fences by which the sheep are confined, but as a proof of the aptitude of the animals to acquire flesh in proportion to the food they consume.

7121. *The long-woolled large breeds* are those usually preferred on good grass-lands; they differ much in form and size, and in their fattening quality as well as in the weight of their fleeces. In some instances, with the Lincolns or old Leicesters in particular, wool seems to be an object paramount even to the carcass; with the breeders of the Leicesters, on the other hand, the carcass has always engaged the greatest attention; but neither form nor fleece, separately, is a legitimate ground of preference; the most valuable sheep being that which returns, for the food it consumes, the greatest marketable value of produce.

7122. *The Lincolnshire, or old Leicestershire breed*, have no horns, the face is white and the carcass long and thin; the ewes weighing from 14 to 20 lbs., and the three-year-old wethers from 20 to 30 lbs. per quarter. They have thick, rough, white legs, bones large, pelts thick, and wool long, from ten to eighteen inches, weighing from 8 to 14 lbs. per fleece, and covering a slow-feeding, coarse-grained carcass of mutton. This kind of sheep cannot be made fat at an early age except upon the richest land, such as Romney Marsh, and the richest marshes of Lincolnshire; yet the prodigious weight of wool which is shorn from them every year, is an inducement to the occupiers of marsh-lands to give great prices to the breeders for their hogs or yearlings; and though the buyers must keep them two years more, before they get them fit for market, they have three clips of wool in the mean time, which of itself pays them well in those rich marshes. Not only the midland counties, but also Yorkshire, Durham, and Northumberland, can send their long-woolled sheep to market at two years old, fatter in general than Lincolnshire can at three. Yet this breed, and its subvarieties, are spread through many of the English counties.

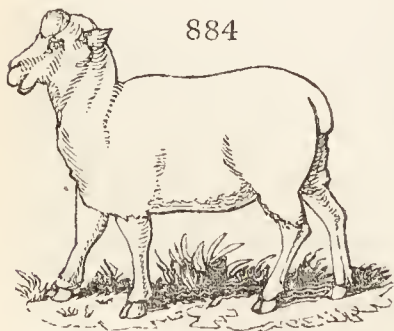
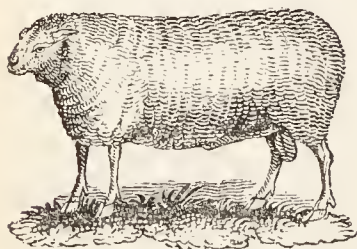
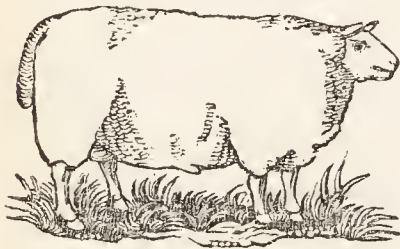
7123. *The Teeswater sheep* (fig. 882.) differ from the Lincolnshire in their wool not being so long and heavy; in standing upon higher, though finer boned legs, supporting a thicker, firmer, heavier carcass, much wider upon their backs and sides; and in affording a fatter and finer grained carcass of mutton: the two-year-old wethers weighing from 25 to 35 lbs. per quarter. Some particular ones, at four years old, have been fed to 55 lbs. and upwards. There is little doubt that the Teeswater sheep were originally bred from the same stock as the Lincolnshire; but, by attending to size rather than to wool, and constantly pursuing that object, they have become a different variety of the same original breed. (*Culley on Live Stock*, p. 122.) The present fashionable breed is considerably smaller than the original species; but they are still considerably larger and fuller of bone than the midland breed.

They bear an analogy to the short-horned breed of cattle, as those of the midland counties do to the long-horned. They are not so compact, nor so complete in their form, as the Leicestershire sheep; nevertheless, the excellence of their flesh and fattening quality is not doubted, and their wool still remains of a superior staple. For the banks of the Tees, or any other rich fat-land county, they may be singularly excellent.

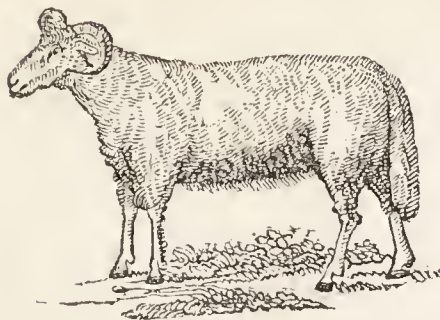
7124. *The Dishley, or new Leicester breed* (fig. 883.), is distinguished from other long-woolled breeds by their clean heads, straight, broad, flat backs, round barrel-like bodies, very fine small bones, thin pelts, and inclination to make fat at an early age. This last property is most probably owing to the before-specified qualities, and which, from long experience and observation, there is reason to believe extends through every species of domestic animals. The Dishley breed is not only peculiar for its mutton being fat, but also for the fineness of the grain, and superior flavour, above all other large long-woolled sheep, so as to fetch nearly as good a price, in many markets, as the mutton of the small Highland and short-woolled breeds. The weight of ewes, three or four years old, is from 18 to 26 lbs. a quarter, and of wethers, two years old, from 20 to 30 lb. The wool, on an average, is from 6 to 8 lbs. a fleece. (*Culley*, p. 106.)

7125. *The Devonshire Nots* (fig. 884.) have white faces and legs, thick necks, narrow backs, and backbone high; the sides good, legs short, and the bones large; weight much the same as the Leicesters; wool heavier, but coarser. In the same county, there is a small breed of long-woolled sheep, known by the name of the *Exmoor* sheep, from the place where they are chiefly bred. They are horned, with white faces and legs, and peculiarly delicate in bone, neck, and head; but the form of the carcass is not good, being narrow and flat-sided. The weight of the quarters, and of the fleece, about two thirds that of the former variety.

7126. *The shorter-woolled varieties, and such as, from their size and form, seem well suited to hilly and inferior pastures*, are also numerous. Generally speaking, they are too restless for enclosed arable land, on the one hand; and not sufficiently hardy for heathy mountainous districts, on the other. To this class belong the breeds of Dorset, Hereford, Sussex, Norfolk, and Cheviot.



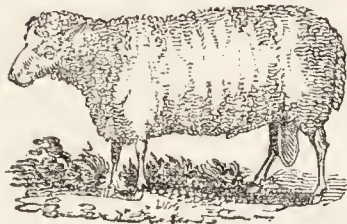
7127. *The Dorsetshire sheep* (fig. 885.) are mostly horned, white faced, stand upon high small white legs, and are long and thin in the carcass. The wethers, three years and a half old, weigh from 16 to 20 lbs. a quarter. The wool is fine and short, from 3 to 4 lbs. a fleece. The mutton is fine grained and well flavoured. This breed has the peculiar property of producing lambs at almost any period of the year, even so early as September and October. They are particularly valued for supplying London and other markets with house lamb, which is brought to market by Christmas, or sooner if wanted, and after that a constant and regular supply is kept up all the winter.



7128. *The Wiltshire sheep* are a variety of this breed, which, by attention to size, have got considerably more weight; viz. from 20 to 28 lbs. a quarter. These, in general, have no wool upon their bellies, which gives them a very uncouth appearance. The variations of this breed are spread through many of the southern counties, as well as many in the west, viz. Gloucestershire, Worcestershire, Herefordshire, &c.; though some of them are very different from the Dorsetshire, yet they are, Culley apprehends, only variations of this breed, by crossing with different tups; and which variations continue northward until they are lost amongst those of the Lincolnshire breeds. (Culley, p. 131.)

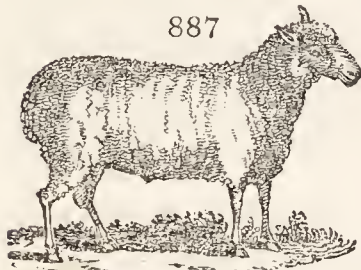
7129. *The Herefordshire breed* (fig. 886.) is known by the want of horns, and their having white legs and faces, the wool growing close to their eyes. The carcass is tolerably well formed, weighing from 10 to 18 lbs. a quarter, and bearing very fine short wool, from 1½ to 2½ lbs. a fleece: the mutton is excellent. The store or keeping sheep of this breed are put into cots at night, winter and summer, and in winter foddered in racks with peas-straw, barley-straw, &c., and in very bad weather with hay. These cots are low buildings, quite covered over, and made to contain from one to five hundred sheep, according to the size of the farm or flock kept. The true Herefordshire breed are frequently called *Ryeland* sheep, from the land formerly being thought capable of producing no better grain than rye; but which now yields every kind of grain. A cross between this breed and the merinos was extensively cultivated by the late Dr. Parry, of Bath, an eminent wool-grower, and promoter of agricultural improvement.

886



7130. *The South Down sheep* (fig. 887.) are without horns: they have dark or black-grey faces and legs, fine bones, long small necks; are low before, high on the shoulder, and light in the fore quarter; the sides are good, and the loin tolerably broad, back-bone too high, the thigh full, and twist good. The fleece is very short and fine, weighing from 2½ to 3 lbs. The average weight of two years old wethers is about 18 lbs. per quarter, the mutton fine in the grain, and of an excellent flavour. These sheep have been brought to a high state of improvement by Elman, of Glynd, and other intelligent breeders. They prevail in Sussex, on very dry chalky downs, producing short fine herbage.

887



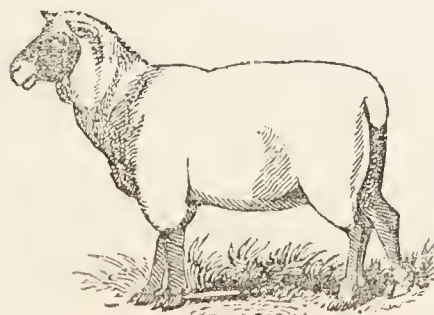
7131. *In the Norfolk sheep* the face is black, horns large and spiral; the carcass is very small, long, thin, and weak, with narrow chimes, weighing from 16 to 20 lbs. per quarter; and they have very long dark or grey legs, and large bones. The wool is short and fine, from 1½ to 2 lbs. per fleece. This race have a voracious appetite, and a restless and unquiet disposition, which makes it difficult to keep them in any other than the largest sheep-walks or commons. They prevail most in Norfolk and Suffolk, and seem to have been retained chiefly for the purpose of folding. As fatteners, they are not profitable; but the mutton produced is inferior to none. A three or four year old Norfolk wether will produce a haunch, which, if kept two or three weeks, will vie with that of any animal excepting a buck.

7132. *The Cheviot breed* are without horns, the head bare and clean, with jaws of a good length, faces and legs white. The body is long, but the fore-quarters generally want depth in the breast, and breadth both there and on the chine; though, in these respects, great improvement has been made of late. They have fine, clean, small-boned legs, well covered with wool to the hough. The weight of the carcass, when fat, is from 12 to 18 lbs. per quarter; their fleece, which is of a medium length and fineness, weighs about 3 lbs. on an average. Though these are the general characters of the pure Cheviot breed, many have grey or dun spots on their faces and legs, especially on the borders of their native districts, where they have intermixed with their black-faced neighbours. On the lower hills, at the extremity of the Cheviot range, they have been frequently crossed with the Leicesters, of which several flocks, originally Cheviot, have now a good deal both of the form and fleece. The best kind of these sheep are certainly a very good mountain stock, where the pasture is mostly green sward, or contains a large portion of that kind of herbage, which is the case of all the hills around Cheviot, where those sheep are bred. Large flocks of them have been sent to the Highlands of Scotland, where they have succeeded so well as to encourage the establishment of new colonies; yet they are by no means so hardy as the heath or black-faced kind, which they have, in many instances, supplanted.

7133. *Of those races of sheep that range over the mountainous districts of Britain*, the most numerous, and the one probably best adapted to such situations, is the *heath* breed, distinguished by their large spiral horns, black faces and legs, fierce wild-looking eyes, and short, firm carcasses, covered with long, open, coarse shagged wool. Their weight is from 10 to 16 lbs. a quarter, and they carry from 3 to 4 lbs. of wool each. They are seldom fed until they are three, four, or five years old, when they fatten well, and give excellent mutton, and highly flavoured gravy. Different varieties of these sheep are to be found in all the western counties of England and Scotland, from Yorkshire northwards, and they want nothing but a fine fleece to render them the most valuable upland sheep in Britain.

7134. *The Herdwick sheep* (fig. 886.) are peculiar to that rocky mountainous district at the head of the Duddon and Esk rivers, in the county of Cumberland. They are without horns, have speckled faces and legs, wool short, weighing from 2 to 2½ lbs. per sheep, which, though coarser than that of any of the other short-woolled breeds, is yet much finer than the wool of the heath sheep. The mountains upon which the Herdwicks are bred, and also the stock itself, have, time immemorial, been farmed out to herds, and from this circumstance their name is derived.

7135. *The dun-faced* breed, said to have been imported into Scotland from Denmark or Norway at a very early period, still exists in most of the counties to the north of the Frith of Forth, though only in very small flocks. Of this ancient race there are now several

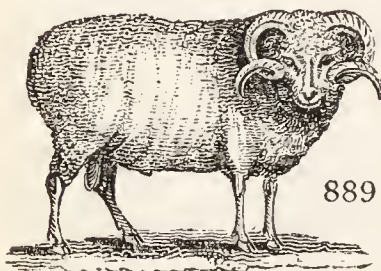


varieties, produced by peculiarities of situation, and different modes of management, and by occasional intermixture with other breeds. We may, therefore, distinguish the sheep of the mainland of Scotland from those of the Hebrides, and of the northern islands of Orkney and Zetland.

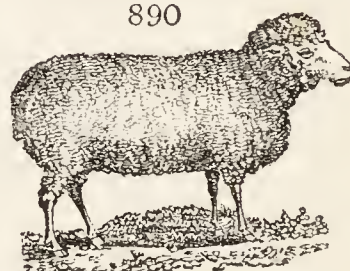
7136. *The Hebridean sheep* is the smallest animal of its kind. It is of a thin, lank shape, and has usually straight shorn horns. The face and legs are white, the tail very short, and the wool of various colours; sometimes of a bluish grey, brown, or deep russet, and sometimes all these colours meet in the fleece of one animal. Where the pasture and management are favourable, the wool is very fine, resembling in softness that of Shetland; but, in other parts of the same islands, the wool is stunted and coarse, the animal sickly and puny, and frequently carries four, or even six horns. The average weight of this poor breed, even when fat, is only 5 or 5½ lbs. per quarter, or nearly about 20 lbs. per sheep. It is often much less, only amounting to 15 or 16 lbs.; and the price of the animal's carcass, skin and all, is from 10s. to 14s. Fat widders have been sold in the Long Island at 7s. a head, and ewes at 5s. or 6s. The quantity of wool which the fleece yields is equally contemptible with the weight of the carcass. It rarely exceeds one pound weight, and is often short of even half that quantity. The quality of the wool is different on different parts of the body; and inattention to separating the fine from the coarse, renders the cloth made in the Hebrides very unequal and precarious in its texture. The average value of a fleece of this aboriginal Hebridean breed is from 8d. to 1s. sterling. From this account it is plain, that the breed in question has every chance of being speedily extirpated. (*Macdonald's Report of the Hebrides*, p. 447.)

7137. *Of the Zetland sheep* it would appear that there are two varieties, one of which is considered to be the native race, and carries very fine wool; but the number of these is much diminished, and in some places they have been entirely supplanted by foreign breeds; the other variety carries coarse wool above, and soft fine wool below. They have three different successions of wool yearly, two of which resemble long hair more than wool, and are termed by the common people *fors* and *scudda*. When the wool begins to loosen in the roots, which generally happens about the month of February, the hairs, or *scudda*, spring up; and when the wool is carefully plucked off, the tough hairs continue fast until the new wool grows up about a quarter of an inch in length, then they gradually wear off; and when the new fleece has acquired about two months' growth, the rough hairs, termed *fors*, spring up and keep root until the proper season for pulling it arrives, when it is plucked off along with the wool, and separated from it, at dressing the fleece, by an operation called *forsing*. The *scudda* remains upon the skin of the animal as if it were a thick coat, a fence against the inclemency of the seasons, which provident nature has furnished for supplying the want of the fleece. The wool is of various colours; the silver grey is thought to be the finest, but the black, the white, the *mourat*, or brown, is very little inferior, though the pure white is certainly the most valuable for all the finer purposes in which combing wool can be used. (*Sir John Sinclair on the different Breeds of Sheep, &c. Appendix, No. 4. Account of the Shetland Sheep, by Thomas Johnston*, p. 79.) In the northern part of Kincardineshire, as well as in most other of the northern counties, there is still a remnant of this ancient race, distinguished by the yellow colour of the face and legs, and by the dishevelled texture of the fleece, which consists in part of coarse, and in part of remarkably fine wool. Their average weight in that county is from seven to nine pounds a quarter, and the mutton is remarkably delicate and highly flavoured. (*Kincardineshire Report*, p. 385. *Sup. E. Brit. art. Agr. 175.*) The Highland Society of Scotland have offered premiums for the improvement of this breed, and some experiments are now in progress. See vol. vi. of their *Transactions*; and for a particular account of the breed itself, and its management, see Shirreff's *Survey of Orkney and Shetland*.

7138. *The Spanish, or Merino breed*, bears the finest wool of the sheep species; the



males (*fig. 889.*) usually have horns of a middle size, but the females (*fig. 890.*) are frequently without horns; the faces and legs are white, the legs rather long, but the bones fine. The average weight per quarter of a tolerably fat ram is about seventeen pounds, and that of ewes about eleven pounds.



7139. *The shape* of this race is far from being perfect, according to the ideas of English breeders, with whom symmetry of proportion constitutes a principal criterion of excellence. The throatiness, or pendulous skin beneath the throat, which is usually accompanied with a sinking or hollow in the neck, presents a most offensive appearance, though it is much esteemed in Spain, as denoting both a tendency to fine wool, and a heavy fleece. Yet the Spanish sheep are level on the back, and behind the shoulders; and Lord Somerville has proved that there is no reason to conclude that deformity in shape is, in any degree, necessary to the production of fine wool.

7140. *The fleece of the Merino sheep weighs*, upon an average, from three to five pounds; in colour, it is unlike that of any English breed: there is on the surface of the best Spanish fleeces a dark brown tinge, approaching almost to a black, which is formed by dust adhering to the greasy properties of its pile; and the contrast between this tinge and the rich white colour below, as well as that rosy hue of the skin which denotes high proof, at first sight excites much surprise. The harder the fleece is, the more it resists any external pressure of the hand, the more close and fine will be the wool: here and there, indeed, a fine pile may be found in an open fleece, though this occurs but rarely. Nothing, however, has tended to render the Merino sheep more unsightly to the English eye than the large tuft of wool which covers the head: it is of a very inferior quality, and classes with what is produced on the hind legs; on which account it does not sort with any of the three qualities, viz. *rafinos*, or prime; *finos*, or second best; and *tercenos*, the inferior sort; and, consequently, is never exported from Spain.

7141. *Merinos were first brought into England in 1788*, but did not excite much interest before his Majesty's sales, which began in 1804: the desirable object of spreading them widely over the country, and subjecting them to the experiments of the most eminent professional breeders, has been greatly promoted by the institution of the Merino Society in 1811, to which belonged some of the greatest landholders, and the most eminent breeders in the kingdom. For some years past, this breed has been on the decline. (*Sup. E. Brit. art. Agr.*) A considerable importation was made by Colonel Downie, of Paisley, which distributed the breed throughout different parts of Scotland. See the *Renfrewshire Survey*. It is not understood that they have answered the expectations that were once formed of them; and I am not aware that there are any flocks in the possession of rent-paying farmers. The only successful experiment in Scotland seems to have been that of the late Mr. Malcolm Laing, in the Orkney Islands; and it is not the pure race, but crosses into other breeds. See the *General Report of Scotland*, vol. iii.

SECT. II. Criteria of Properties in Sheep.

7142. *The criteria of an excellent ram*, as given by Culley, combines qualities which ought to be found in every breed of sheep cultivated for its flesh and wool. His head should be fine and small; his nostrils wide and expanded; his eyes prominent, and rather bold or daring; ears thin; his collar full from his breast and shoulders, but tapering gradually all the way to where the neck and head join, which should be very

fine and graceful, being perfectly free from any coarse leather hanging down; the shoulders broad and full, which must, at the same time, join so easy to the collar forward and chine backward as to leave not the least hollow in either place; the mutton upon his arm or fore-thigh must come quite to the knee; his legs upright, with a clean fine bone, being equally clear from superfluous skin and coarse hairy wool, from the knee and hough downwards; the breast broad and well formed, which will keep his fore-legs at a proper wideness; his girth or chest full and deep, and instead of a hollow behind the shoulders, that part, by some called the fore-flank, should be quite full; the back and loins broad, flat, and straight, from which the ribs must rise with a fine circular arch; his belly straight, the quarters long and full, with the mutton quite down to the hough, which should neither stand in nor out; his twist, or junction at the inside of the thighs, deep, wide, and full, which, with the broad breast, will keep his four legs open and upright; the whole body covered with a thin pelt, and that with fine, bright, soft wool.

7143. *The criteria of a sound healthy sheep* are, a rather wild or lively briskness; a brilliant clearness in the eye; a florid ruddy colour on the inside of the eyelids, and what are termed the eyestrings, as well as in the gums; a fastness in the teeth; a sweet fragrance in the breath; a dryness of the nose and eyes; breathing easy and regular; a coolness in the feet; dung properly formed; coat or fleece firmly attached to the skin, and unbroken; the skin exhibiting a florid red appearance, especially upon the brisket. Where there are discharges from the nose and eyes, it indicates their having taken cold, and should be attended to by putting them in dry sheltered situations. This is a necessary precaution also in bringing them from one situation to another while on the road.

7144. *The criteria of the age of sheep* is the state of their teeth; by their having, in their second year, two broad teeth; in their third year, four broad teeth; in their fourth year, six broad teeth; and in their fifth year, eight broad teeth before. After which, none can tell how old a sheep is while their teeth remain, except by their being worn down. About the end of one year, rams, wethers, and all young sheep, lose the two fore-teeth of the lower jaw; and they are known to want the incisive teeth in the upper jaw. At eighteen months, the two teeth joining to the former also fall out; and at three years, being all replaced, they are even and pretty white. But as these animals advance in age, the teeth become loose, blunt, and afterwards black. The age of all horned sheep may also be known by their horns, which show themselves in their very first year, and often at the birth, and continue to grow a ring annually to the last period of their lives.

7145. *The different ages and conditions of sheep* have different names in different districts. After being weaned, the ram, or wedder lamb, is sometimes termed hog, hoggit, or tag, during the whole of the first year; and the female lamb, an ewe, or gimmer lamb, and ewe tag. The second year the wedder has the title of shear hog, or a two-toothed tag; and the ewe is called a thaive, or two-toothed ewe. In the third year, a shear hog, or four-toothed wedder; and a four-toothed ewe or thaive. The fourth year, a six-toothed wedder, or ewe; and in some places, from the time of lambing till that of salving, the males are called tup-lambs; and from that period, till the time of shearing, tup-hogs, and ever afterwards, tups: the females in the same order being termed, ewe-lambs, ewe-hogs, gimmers, young ewes, old ewes. The gelded male lambs, castrated wedder lambs, wedder hogs, dummonds, wedders. Crones also signify old ewes; and there are several other provincial names, which are explained in their proper places.

SECT. III. *Breeding of Sheep.*

7146. *In the breeding of sheep* a greater degree of perfection has been attained than in any other live stock; and in this branch, in particular, the breeders of England stand higher than those of any other country.

7147. *Bakewell*, by careful selection during several generations, raised his stock to a state of excellence, in regard to fattening at an early age with a moderate consumption of food, and with the smallest proportion of offal, which has been with difficulty equalled, certainly has not been exceeded, by the most skilful of his successors. It is a striking instance of the division of labour and skill, that there are breeders who devote themselves entirely to the breeding of rams for the purpose of letting out on hire. This practice originated in Lincolnshire, where, in the early part of the last century, rams were let out at from 10s. to 20s. each; but so great has been the improvement since that period, that they are now let out to common graziers at from 1 to 10 guineas, and to breeders of rams at from 20l. to 200 guineas. The breeding rams are shown for hire at certain times and places during the summer, where every one may select such as promise to maintain or improve the particular state of his flock, and at such prices as his means and experience may justify. Two or more individuals frequently join together in the hire of one ram, to which they put the best of their ewes, for the purpose of obtaining superior males for the future service of the rest of their flocks; and in particular cases, when the owner of the ram does not choose to part with him, even for a season, ewes are sent to him to be covered at a certain price per head; superior animals of this class being very seldom sold altogether. Much as this mode of doing business has been reprobated as a monopoly, and much as there sometimes may be of deception in *making up* rams for these shows, all intelligent practical men must agree, that there can be no better method of remunerating eminent breeders, and of spreading their improvements most widely, in the shortest period, and at the least possible expense. A single ram thus communicates its valuable properties to a number of flocks, often in distant parts of the country, without distracting the attention of ordinary breeders from their other pursuits.

7148. *The two methods of breeding* common to all animals are also adopted in breeding sheep. Breeding from different families of the same race, commonly called breeding *in and in*; and breeding from different races, generally called *cross breeding*. Bakewell, according to Sir J. Sebright (*On improving the Breeds of domestic Animals, &c.*), effected his improvements by breeding from the same family; but according to Hunt, who has written an able answer to Sir J. Sebright's pamphlet (*A Letter, &c. to Sir J. Sebright, &c.*), he bred from different relationships of the same family; it being out of his power to breed from different families of a race which he was at the time employed in forming, and cross breeding he did not approve of. Breeding *in and in* is so repugnant to human feeling, that it is difficult to avoid considering it an unnatural practice; for it does not follow that a flock of sheep in a wild state must necessarily breed in the nearest relationships, as father and daughter, &c.; on the contrary, it is more probable that remoter relationships would be chiefly bred from, as these must necessarily be much more numerous. In a flock of sheep, or a herd of savage men, springing each from one pair, every parent must necessarily have many more cousins, and cousins many times removed, than he can have mothers or daughters.

7149. *Breeding from different families of the same race* is the more general and approved practice. When a number of families of any breed have been for some time established in a variety of situations, and have had some slight shades of difference impressed upon them, by the influence of different soils and treatment, it is found advantageous to interchange the males, for the purpose of strengthening the excellencies, or remedying the defects of each family. Of this advantage Bakewell could not avail himself; but it has been very generally attended to by his successors. Culley, for many years, continued to hire his rams from Bakewell, at the very time that other breeders were paying a liberal price for the use of his own; and the very same practice is followed by the most skilful breeders at present. In large concerns, two or more streams of blood may be kept distinct for several generations, and occasionally intermixed with the happiest effects, by a judicious breeder, without having recourse to other flocks. (*Sup. E. Brit. art. Agr. 177.*)

7150. *In breeding from two distinct races*, the object is to acquire new properties or remove defects. The mode of effecting this by cross breeding is attended with greater difficulties than in breeding from the same race. The very distinction of breeds implies a considerable difference among animals in several respects; and although the desirable property be obtained, it may be accompanied by such others as are by no means advantageous to a race, destined to occupy a situation which had excluded that property from one of its parents. To cross any mountain breed with Leicester rams, for example, with a view to obtain a propensity to fatten at an early age, would be attended with an enlargement of size, which the mountain pasture could not support; and the progeny would be a mongrel race, not suited to the pastures of either of the present breeds. If the object be to obtain an enlargement of size, as well as a propensity to fatten, as is the case when Cheviot ewes are crossed with Leicester rams, the progeny will not prosper on the hilly pastures of their dams, and will be equally unprofitable on the better pastures of their sires. But the offspring of this cross succeeds well on those intermediate situations on the skirts of the Cheviot hills, where, though the summer pasture is not rich, there is a portion of lowland for producing clover and turnips. (*Supp. Encyc. Brit. art. Agr. &c.*)

7151. *As general rules in crossing breeds*, it is to be noticed that in every case where the enlargement of the carcass is the object, the cross breed must be better fed than its smaller parent. The size of the parents should also be but little disproportioned at first; and when some increase has been produced, one or more crosses afterwards may raise the breed to the required size. With these precautions, there is little reason to fear disappointment, provided both parents are well formed. (*General Report of Scotland*, vol. iii. p. 14. 18.)

7152. *The most advantageous and proper age for ewes taking the ram* in the different breeds has not been fully shown; but from a year to a year and a half old may be sufficient, according to the forwardness of the breed and the goodness of the keep. Some judge of this by the production of *broad* or sheep's teeth. It should not be done while too young in any case. Ewes commonly bring their first lamb when two years old; in the hilly and mountainous districts of Scotland commonly not for a year after. Of course, they are usually eighteen or nineteen months old when they take the ram, throughout all the lowland districts.

7153. *In regard to the season of putting the rams to the ewes*, it must be directed by the period at which the fall of the lambs may be most desirable, which must depend on the nature of the keep which the particular situation affords; but the most usual time is about the beginning of October; except in the Dorsetshire ewes, where the intention is suckling for house-lamb, in which case it should be much earlier, in order that the lambs may be sufficiently forward. But, by being kept very well, any of the breeds will take the ram at a much earlier period. Where the rams are young, the number of ewes should seldom exceed sixty for each ram; but in older rams a greater number may be admitted without inconvenience, as from one to two hundred; but letting them have too many should be cautiously avoided, as by such means the farmer may sustain great loss in the number of the lambs.

7154. *With respect to the period of gestation*, the ewe goes with lamb about the space of five months, consequently the most common lambing season is March, or the early part of April; but "it has been observed that in many of the more southern districts, where sheep-husbandry is carried on to a considerable extent, some parts of the ewe-stock are put to the rams at much earlier periods, so as to lamb a month or six weeks sooner; a practice which is attended with much profit and advantage in many situations where early grass-lamb is in great demand. It is usual for the rams to remain with the ewes for a month or six weeks, and in some cases longer, in order to complete the business of impregnation, which in some districts is ascertained by smearing the fore-bows of the rams with some colouring substance."

7155. *The practice of turning a number of rams among the flocks* formerly adopted is highly exceptionable, as tending to prevent the main object and injure the rams. A better way is to let each ram have a proper number of ewes, and with very choice stock to keep the ram in an enclosed small pasture, turning a few ewes to him, and as they are served replacing them with others. By this means there is more certainty, and more ewes may be impregnated. In such sort of fine stock, it is likewise of great utility to keep the rams during this season in a high manner. In this view a little oats in the straw, or a mixture of barley and pea meal, are excellent. Where ewes are backward in taking the ram, the best means to be employed are those of good stimulating keep. The rams should always be continued with the ewes a sufficient length of time.

7156. *The ewe will breed twice a year*, if it be made a point to produce such an effect by attention and high keep; since she will receive the male indifferently at any season, and, like the rabbit, very soon after bringing forth. Lisle gives an instance of three of his ewes, well kept, lambing at Christmas, fattening off their lambs at Lady-day, and producing lambs again the first week in June. It seems they stole the ram immediately after lambing, but brought the second time only single lambs, although of a breed that generally produces twins. There is no doubt but the sheep would produce young thrice a year were the bad practice resorted to, which has been so currently recommended with the rabbit, of allowing the male immediately after parturition; the ready way to render both the female and her progeny worthless. Could the lambs be advantageously weaned at two months, sufficient time would, he conceives, remain for the ewe to bring forth twice within the year. For example, suppose the young ewe tupped in August, the lamb would be dropped in the middle of January, and might be weaned in mid March, the ewe again receiving the ram on the turn of the milk, like the sow, perhaps in or before April, she would then bring forth within the twelve months or in August. This plan would, continues Lisle, at least injure the dam infinitely less than suckling during gestation.

7157. *When ewes are in lamb they should be kept in the pastures, and as free from disturbance as possible*, being carefully attended to in order to prevent accidents which are liable to take place at this time, such as those of their being cast in the furrows, &c. Where any of the ewes slip their lambs, it is advised by Banister that they should be immediately removed from the flock. They also require, under these circumstances, to be kept as well as the nature of the farm will admit, in order that there may be less loss at lambing-time from the ewes being stronger, and the lambs more healthy and better capable of contending with the state of the season at which they may be dropped. The shepherd should at this period be particularly careful and attentive to afford his assistance where it may be necessary. He should constantly have regard to the suckling of the lambs, and to see that the udders of the ewes are not diseased. His attendance will often be required in the night as well as the day. At this season covered sheep-folds are often of very great advantage in saving and protecting both ewes and their lambs.

7158. *In respect to the number of lambs at a birth* it is remarked by Lawrence, that the ewe brings most commonly one, next in degree of frequency two, rarely from three to five lambs at a birth. This property of double birth is, he says, in some instances specific; the Dorset sheep usually yeaving twins, and the large polled Belgic sheep, with their descendants our Teeswater, doing the same, and producing occasionally more at a birth. Other breeds bring twins in the proportion of one third of the flock, which is supposed to depend considerably on good keep. A certain number of ewes per centum prove barren annually: the cause very rarely natural defect; sometimes over-fatness, a morbid state of body from poverty or neglect of the ram; in other words, want of system in the shepherd.

7159. *The keep of sheep after lambing*, where rich pastures or other kinds of grass lands cannot be reserved, should consist of turnips or other kinds of green food provided for the purpose, and given them in a suitable manner; but where it can be done, it is always better to leave this sort of food untouched till about the period of lambing, when it should be regularly supplied in proportion to the necessity there may be for it. The ewes also demand at this time much care to see that they are put upon a dry sheltered pasture, free from disturbance, and that neither they nor their lambs sustain injury from the too great

severity of the season. Whenever this is the case, they should be carefully removed into a proper degree of warmth and shelter till perfectly restored. It is likewise a necessary as well as useful practice, as they lamb down, to take them and their lambs away from the common stock, putting them into a piece of turnips or fresh dry pasture where there is shelter when necessary, as by this means much fewer lambs would be lost than would otherwise be the case. It is also found, that by a proper supply of turnips or other similar green food at this period, the milk of the ewes is much increased, and the growth of the lambs greatly promoted; which is of much future importance, as when they are stinted at this early period of their existence, they never turn out so well afterwards for the farmer. With the green and root crops and preserved after-grass, hay, straw, corn, and oil-cake are in some cases made use of in the winter support of sheep stock. With turnips, where the soil is not sufficiently dry to admit the sheep, it is the practice to draw them and convey them to a sound firm pasture, that the ewes may be baited upon them once or twice in the day as there may be occasion, care being taken that they are eaten up clean, as the circumstance of their being thus eaten may serve as a guide to the farmer for the supply that may be daily necessary. In this way this sort of food will be consumed with the greatest economy. Where the land is perfectly dry, and the intention is to manure it for a grain crop, eating the turnips on the land, by means of portions hurdled off as wanted, is a good practice. With this sort of food, especially where it produces scouring in the ewes, green rouden hay, cut straw, or peas haulm should constantly be given, and also with rape, &c.

7160. *The castrating lambs* may be performed any time from the age of a fortnight or three weeks to that of a month or six weeks, and in some districts it is deferred to a considerably later period. It is, however, the safest method to have it executed early, as there is less danger of too much inflammation taking place. But in all cases the lambs should be in a healthy state when it is done, as under any other circumstances they are liable to be destroyed by it. The operation is usually performed by the shepherd, by opening the scrotum or cod and drawing out the testicles with the spermatic cord. This he often does with his teeth in the young state of the animal; but where the operation is performed at a later period, it is usual to have recourse to the knife, the arteries being taken up and secured by means of ligatures, or the searing iron. The business, if possible, should be done in fine weather, when not too warm, and the gelded lambs be kept in a dry, sheltered, quiet situation for a few days, until the inflammation is gone off. If it should happen to be wet at the time, it may be advisable to have them under some sort of shelter where they can have room to move freely about.

7161. *The weaning of lambs* should be effected when they are three or four months old, as about July; but it is done more early in some districts than in others. A proper reserve of some fresh pasture grass, where there may be a good bite for the lambs to feed upon, should be had recourse to, as it is of much consequence that an ample provision of this sort be had, in order that the growth of this young stock may not suffer any check on being taken from the mother. Where they have been continued so long as to graze with the dams, little check will be sustained in their separation if turned upon such good feed. Some advise clover in blossom as the most forcing sort of food in this intention, and with others saintfoin rouden is highly valued for the same purpose. When good feed is not provided of some of these kinds, the lambs soon decline in flesh, or, in the technical language of the flock, are said to pitch; and when once this happens they never afterwards thrive so well, however good the management may be. With regard to the ewes, they should be removed to such distant pastures or other places as that they may not be heard by the lambs, which would cause them to be disturbed in their feeding; and where the ewes sustain any inconvenience from their milk, as by their udders swelling, it should be drawn once or twice, as by this means bad consequences may be prevented: and as soon as the lambs have been removed, the ewes are returned upon the pastures destined for their summer support. There is, however, one caution to be attended to in first turning the lambs upon rich keep, which is that of letting them be in some degree satisfied with food previously, that they may not be surfeited by too quick and full feeding, and *hove* or *hove* as it is termed; keeping them gently moving about the field has also been advised in this intention. In some places, where the lands are of the more poor kind, it is a custom to send the lambs to the more rich vale or marsh districts, to be brought forward in condition or fattened. In those cases where the lands of the male kind are reared on the home lands as wethers, they are usually restored to the flock in the latter end of the year, but which is not by any means a good practice, as they often suffer for want of proper keep in the winter, and lose what they had previously gained in growth and condition. A practice the reverse of this has long been in use among the store-masters of Scotland. They send their lambs, as soon as weaned, to some rough coarse pasture, often at a distance of several miles, where they remain for six or eight weeks. The opinion is, that this renders them more hardy. Some grounds are occupied chiefly for this purpose, being kept for summering lambs, as it is called, the owner of the lamb paying a penny or three halfpence a week for each. The practice, it is believed, is not now so common as it has been.

SECT. IV. *Rearing and general Management of Sheep.*

7162. *In the practice of sheep husbandry different systems are had recourse to*, according to the extent and nature of the farms on which they are kept, and the methods of farming that are adopted on them; but under all circumstances the best sheep-masters constantly endeavour to preserve them in as good condition as possible at all seasons.

7163. *With the pasture kinds of sheep* this is particularly the case; and with the view of accomplishing it in the most complete manner, it is useful to divide them into different parcels or lots in respect to their ages and sorts, as by that practice they may be kept with greater convenience and benefit than in large flocks together under a mixture of different kinds; as in this way there is not only less waste of food, but the animals thrive better, and the pastures are fed with much more ease. The advantage of this management has been fully experienced in many of the northern districts, where they usually divide the sheep stock into lambs, yearlings, wethers, and breeding ewes: and in this method it appears not improbable that a much larger proportion of stock may be kept, and the sheep be preserved in a more healthy condition. With a breeding stock the sheep-master must act according to his circumstances, situation, and capital which he possesses, either selling the lambs to go to keep, fattening them for grass lamb, suckling them for house lamb, or keeping them on to be grazed and sold as store or fat wethers; the ewes being sold lean or in store condition, or fattened, as circumstances, profit, and convenience may point out.

7164. *Another practice*, but which requires much capital as well as knowledge, experience, and attention, is that of breeding and fattening off all lambs, both wethers and ewes, especially where markets for their sale when fat are conveniently situated; or this system may be partially acted upon, varying the plan according to capital, circumstances, and the nature of the times. In which case, whenever store stock become extravagantly high, it is mostly a good way to sell.

7165. *The sheep farming of the arable or low warm districts of the kingdom* consequently differs in various particulars from that of the hilly and mountainous districts; we shall, therefore, first give a general view of the sheep management of arable lands, and next of mountainous districts.

SUBJECT. 1. *Rearing and Management of Sheep on rich grass and arable Lands.*

7166. *The most general sheep husbandry on rich lands, or where turnips and other green food is raised for winter consumption, is to combine the breeding and feeding branches, leaning to each according to the returns of profit.*

7167. *A method very common among arable farmers, and which is attended with the least trouble and hazard, is that of purchasing a store flock, as lambs, wethers, and what are termed crones, or old ewes; some of the last sort often proving with lamb, may be fattened off with them to good account. It is likewise often the case that ewes are disposed of in lamb, or with lambs by their sides, in what are termed couples, in which circumstances it is frequently a good practice to make annual purchases of them, in order to the fattening of both, and selling them in that state within the year. In the purchasing of sheep, which is often done from very distant fairs and markets, much care and circumspection is necessary, whatever the sort or intention with which they are bought may be. In these cases much advantage, especially when at a considerable distance, may be derived by employing a salesman on the spot.*

7168. *The treatment of the lambs is the first consideration in the mixed sheep husbandry.*

7169. *Lambs are either suckled or fattened on grass, or sold in autumn as lean stock. With regard to those that have been suckled or fattened in the house, much attention is required to have them early, to their being well, regularly, and very cleanly kept and suckled, as well as to the ewes being of the right sort, and the best milkers that can be provided, and to their being fully supplied with food of the most nourishing and succulent kinds. Their tails and udders should have the wool well clipped away from them, in order that they may be preserved in a perfectly clean state. The lambs also require, especially towards the close of their fattening, to have regular supplies of barley, wheat, and peas-meal, ground together in combination with fine green rouen hay. When these have been sold off, the lambs which have been fattened on the best grass land will be ready to succeed them at the markets, in the spring and summer months, and these will be followed by the sale of the store lambs, at the different autumnal fairs.*

7170. *The selection or setting of the lamb-stock is the first business of sheep management after the lambs have been weaned.*

7171. *It is generally performed in the month of July or August, at which period the fairs for the sale of lambs mostly take place. And as at this time the whole are collected together for drawing into different lots, it is a very suitable period for selecting or choosing those that are to supply such deficiencies in the breeding flocks. In his *Calendar of Husbandry*, Young has remarked, that in making this selection the farmer or his shepherd usually (whatever the breed may be) rejects all that manifest any departure from certain signs of the true breed: thus, in a Norfolk flock, a white leg, and a face not of a hue sufficiently dark, would be excluded, however well formed; in the same manner a white face on the South Downs; in Wiltshire, a black face would be an exclusion, or a horn that does not fall back; in Dorsetshire, a horn that does not project, &c.*

7172. *The selection of the grown stock generally takes place after the lambs are weaned, or, at all events, before tupping season, though wethers may be drawn out of the flock at any time. A certain number of old ewes or crones are removed every year, and these as well as the wethers are fed off for the butcher, either on grass, artificial herbage, or roots, according to the situation and circumstances of the farm, and season of the year.*

7173. *The shearing of sheep is an annual operation, which includes several preparatory measures and after-processes. These are, washing, separation, catching, clipping, marking, and tail-cutting.*

7174. *The proper time for clipping or shearing sheep must be directed by the state of the weather and the climate in the particular district, as by this means the danger of injury by cold from depriving the sheep of their coats at too early a season, and from heat by permitting them to continue on them too long, may be avoided in the best manner: but another circumstance that should likewise be attended to in this business, is that of the wool being fully grown or at the state of maturity; as where the clipping precedes that period, it is said in the *Annals of Agriculture* to be weak and scarcely capable of being spun, and if protracted later, it is yellow, felted, and of an imperfect nature. It has been stated, that for the more warm sheltered situations in the southern parts of the kingdom, the beginning or middle of June, when the weather is fine, may be in general the most proper; but in the more exposed districts in the northern parts of the island, the middle or latter end of the same month may be more suitable, provided the season be favourable. But with the fattening sheep in the enclosures, it will mostly be necessary to perform the work at an earlier period in every situation, as the great increase of heat from the setting in of the summer weather, added to the warmth of the fleece, becomes very oppressive and injurious to them in their feeding. There never can be any difficulty in ascertaining the proper time for shearing, because the separation of the old wool from the new is always distinctly marked in a thriving sheep; and this happens earlier or later according to the age and condition of the animal. Hence, from the beginning of May, or earlier, till the first week of July, shearing goes on in different districts; beginning with the fat Leicester wethers, and ending with the small nursing ewes of the Highland districts. From the middle of May to the middle of June is the busiest period.*

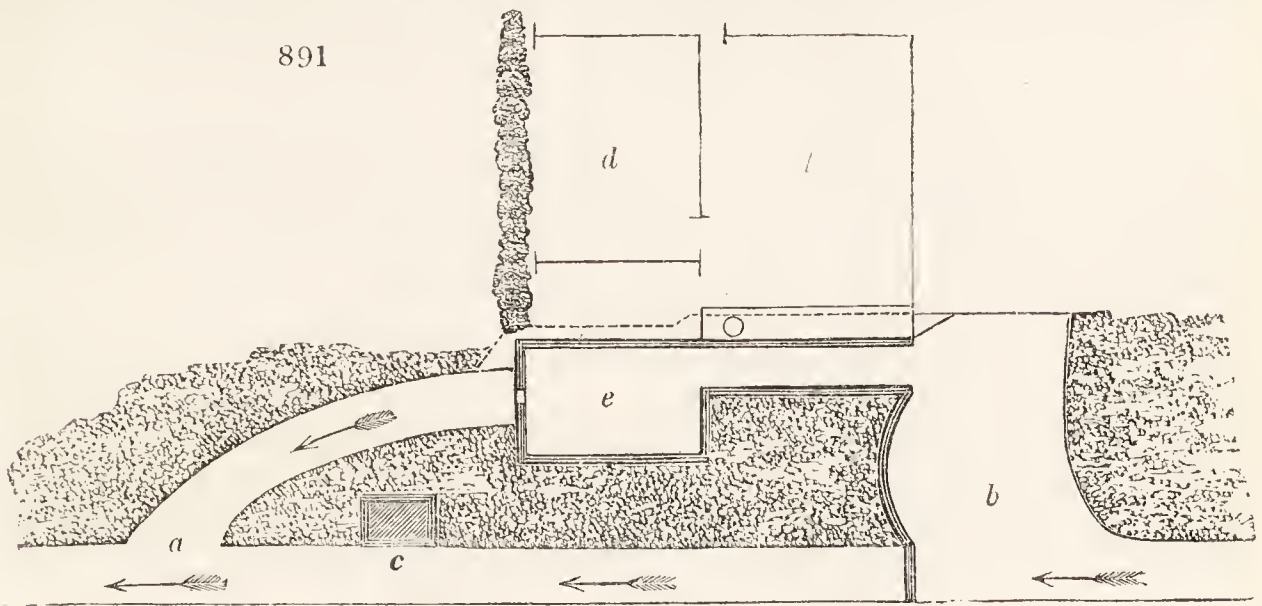
7175. *Sheep-shearing in Romney Marsh commences about midsummer, and finishes about the middle of July. Those who shear first think they escape the effects of the fly, and those that shear late apprehend they gain half a pound weight in every fleece, by the increased perspiration of the sheep. In early shearing, the wool has not the condition which it afterwards acquires; but the hot weather occasions a good deal of trouble in detecting the fly. The lambs that are sold in Smithfield market are, we believe, seldom or ever shorn. All over the north of England, and throughout Scotland, lambs are never shorn. They lose their first fleece when about fifteen months old.*

7176. *Clipping off the coarse soiled wool about the thighs and docks, some weeks before the usual time of washing and clipping the sheep, is an excellent practice; as by this means the sheep are kept clean and cool when the season is hot, and with ewes the udders are prevented from becoming sore.*

7177. *In separating for the purpose of washing, the flock is brought to the side of the washing-pool, and there lambs and sheep of different kinds, fit to be washed, are put into separate fields; and such lambs as are too young to be clipped are not washed, but confined in a fold or enclosure of any kind, at such a distance from the washing place as that they may not disturb their mothers by their bleating. The object of washing is simply*

to free the fleece from dust and dirt of various kinds. In Devonshire and Spain, the short-woolled sheep are not washed.

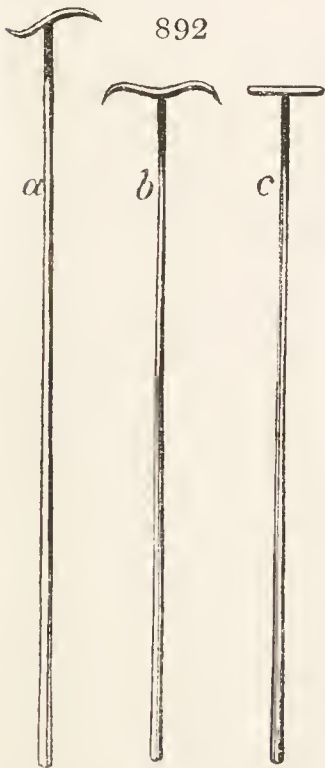
7178. *In performing the operation of washing*, it was formerly the method, and it still exists in the north, to have the washers standing up to the breast in the water; but from the inconvenience and danger of it, the men requiring a large supply of spirituous liquors, and being liable to be attacked with colds, rheumatisms, and other diseases, as well as being apt to despatch the work with too much expedition, so as to leave the wool insufficiently clean, it has been proposed by Young, in his *Calendar*, to rail off a portion of the water in a stream or pond (*fig.* 891.), for the sheep to walk into by a sloping mouth at one end (*a*),



and to walk out by another at the other end (*b*), with a depth sufficient at one part for them to swim; and to pave the whole: the breadth need not be more than six or seven feet. At one spot on each side of this passage, where the depth is just sufficient for the water to flow over the sheep's back, a cask or box (*e*), water tight, should be fixed, for a man to stand in dry; the sheep being in the water between them, they wash in perfection, and pushing them on, they swim through the deep part, and walk out at the other mouth, where a clean pen (*d*), or a very clean dry pasture, is ready to receive them; of course there is a bridge railway to the tubs, and a pen at the first mouth of the water (*e*), whence the sheep are turned into it, where they may be soaking for a few minutes before being driven to the washers. But other more cheap contrivances may be provided, where there is clean water at hand for the purposes.

7179. *After sheep are washed*, they should on no account be driven on dry or dusty roads; but should have a clean hard pasture for a few days, until they are perfectly dry and in a proper condition to be shorn.

7180. *The common method of catching the sheep*, in order to lay it on its back to be shorn, is by the hinder leg, drawing the animal backward with a crook (*fig.* 892. *a, b, c*) to the adjacent shearing place; the hand holding the leg to be kept low, when at the place it is turned on its back; or they are moved bodily, or one hand placed on the neck, and another behind, and in that manner walked along: the first or common mode he thinks the most safe. Sheep fed on rich pastures, and fleshy, if handled hard and bruised, the parts are liable to fatal mortifications; an accident which often happens, on which accounts pens upon some lands are obliged to be lined with woollen, or many would die from bruises.



7181. *In performing the operation of shearing*, the left side of the sheep is placed against the shearer's left leg, his left foot at the root of the sheep's tail, and his left knee at the sheep's left shoulder.

7182. *The process commences* with the shears at the crown of the sheep's head, with a straight cut along to the loins, returning to the shoulder, and making a circular shear around the off side to the middle of the belly; the off hinder leg next: then the left hand holding the tail, a circular shear of the rump to the near huck of the sheep's hind leg; the two fore feet are next taken in the left hand, the sheep raised, and the shears set in at the breast, when the remaining part of the belly is sheared round to the near stifle; lastly, the operator kneeling down on his right knee, and the sheep's neck being laid over his left thigh, he shears along the remaining side.

7183. *The method in Northumberland*, introduced by the Messrs. Culley, is to begin at the back part of the head, in order to give room for the shears to make their way down the right side of the neck, to the middle of the breast. The man then sits down upon his right knee, laying the head of the sheep over his left knee bent, and beginning at the breast, clips the underside of the throat upwards to the left check; then takes off the back of the neck, and all the way down below the left shoulder. He then changes to the contrary side, and makes his way down to the open of the right flank. This done, he returns to the breast, and takes off the belly, after which it matters not which side he clips, because being able to clip with either hand, he meets his shear points exactly at the middle of the back, all the way, until he arrive at the thighs or legs. He then places the sheep on its left side, and putting his right foot over the neck, and the other forward to the undermost hind leg, clears the right side; then turning the sheep over, finishes the whole.

7184. *The fleece being removed*, is wound up; that is, deprived of any clotted wool or dirty part, and lapped with the shorn side outwards, beginning at the breech and ending at the shoulders, where the neat wool serves as a bandage.

7185. *Marking* is performed on each sheep about a week after the fleece is removed. The object is to identify the individuals as the property of the master. Sometimes initials are impressed, and at other times other marks. They are impressed by stamps, or merely chalked or painted on. A stamp dipped in warm tar is the most durable mode. Some place the mark on different parts of the sheep, according to its age; others cut the margin of the ears in different ways.

7186. *Shortening the tails of the sheep* is performed in almost all the sheep districts of the kingdom except in Dorsetshire, which seems to be a useful practice, especially with long-woolled sheep, in keeping the animals more clean behind, and of course less liable to be stricken with the fly.

7187. *It has, however, been suggested* in the ninth volume of *Annals of Agriculture*, that by this custom the sheep may be rendered less able to drive away the flies. The general prevalence of the practice would, however, seem to prove its being of advantage. There is much difference in the manner of performing the business in different districts in respect to the length, but four or five inches being left is quite sufficient. It is usually done while the animals are young. In all sheep pastures the hedges should be well cleared from briars, as their coats are often injured by being torn by them. And all sorts of pernicious reptiles should be as much as possible destroyed, and removed from such land.

7188. *The mode of pasturing sheep, or of feeding them* on herbage or roots having been described when treating of these crops, the more general practices of rearing and management of lowland sheep husbandry may be considered as developed. Some peculiar practices and the mode of fattening lambs will be found in subsequent sections.

7189. *The practice of giving salt to sheep* deserves to be generally recommended. It is given in small long troughs every day throughout the year, and in rainy weather twice a day, or under cover, that it may not be washed away. The practice is particularly recommended, when sheep are first put to turnips. As to the quantity for each sheep, it is said that any quantity may be laid before them, and that no danger, but the reverse, will result from their having at all times as much as they will voluntarily take.

SUBJECT. 2. *Rearing and general Management of Sheep on Hilly and Mountainous Districts, or what is generally termed Store Sheep Husbandry.*

7190. *The best store farmers* in Britain are unquestionably those on the Cheviot hills, which border the two kingdoms; and an account of their management may be considered as applicable to the mountainous districts of the whole kingdom. It is, indeed, applied by the migrations of the Cheviot and Teviotdale farmers, both in the North Highlands, on the Sutherland estate, and in Wales. No regular system of store farming, as observed by Napier (*Treatise on Store Farming*), appeared previously to his own; and accordingly from this work, and an excellent account published in the *Supplement to the Encyclopædia Britannica*, we have extracted what follows.

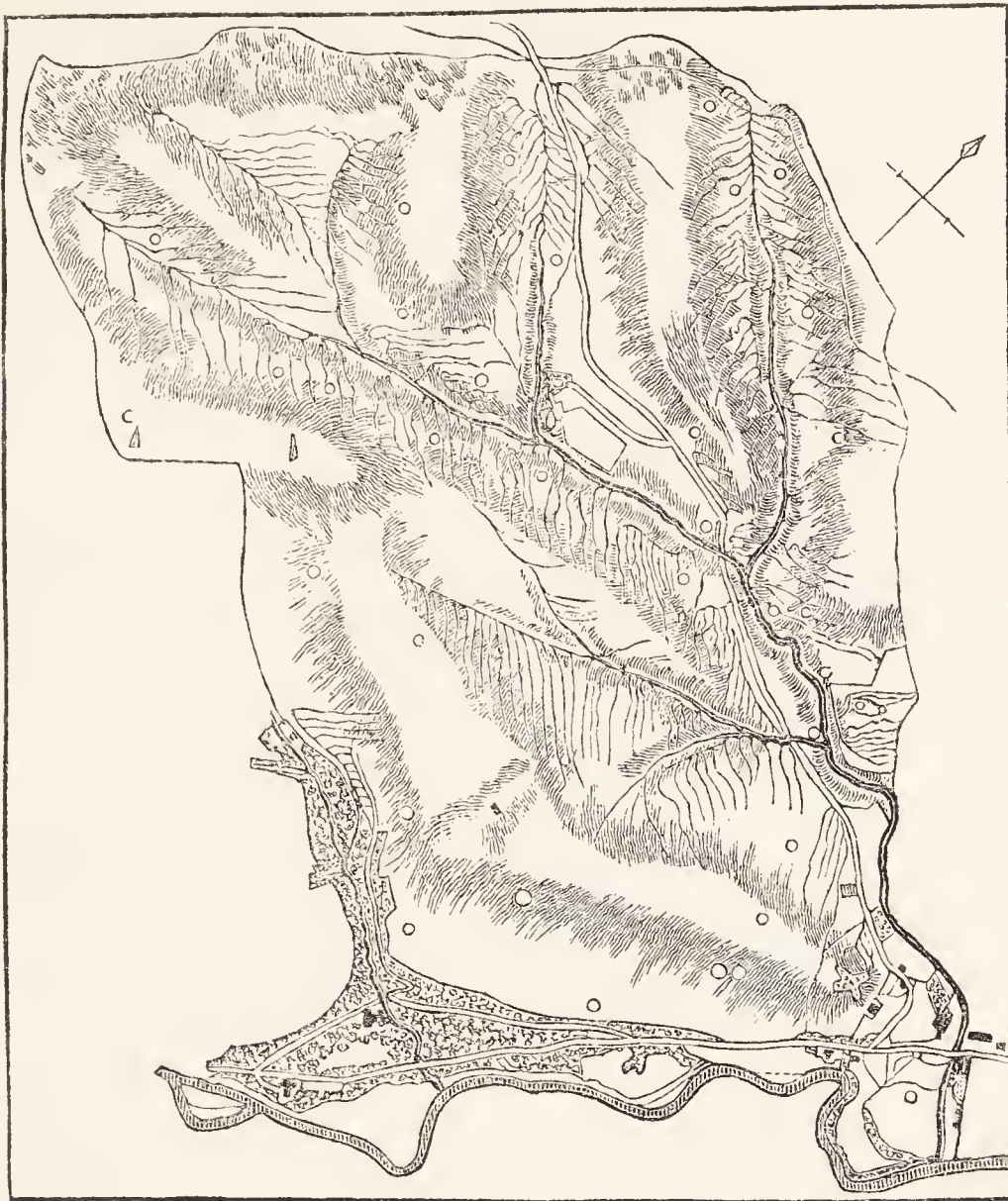
7191. *A general idea of the extent and nature of a store farm* may be obtained by referring to that of Thirlstane in Ettrick forest, a plan of which (*fig. 893.*) is given by Captain Napier. It contains one thousand six hundred and fifty-one acres; of which one thousand four hundred and sixty-four acres are in open hill pasture, seventy in plantation, forty in arable and meadow, about sixty in six enclosures, and the rest in shepherds' and other cottagers' houses, with their allowance of ground for a garden and cow. What distinguishes this farm from most others is the number of stells, or small circular enclosures (○) for sheltering and feeding sheep during storms of snow, which are distributed over it; being no fewer than thirty-seven. The advantages of these stells in districts where sheep are liable to be buried by snow Captain Napier considers very great, and to promote their more general introduction seems to have been one principal inducement for publishing his book. We shall recur to the subject in the following section, when treating of coting, folding, housing, &c. In the mean time, we are informed that Captain Napier's round stells are not generally approved of, but that one is preferred which has four concave sides. See *Fairbairn's Treatise on Store Farming*, Edin. 8vo. 1825.

7192. *In the practice of store farming* the rams are put to the ewes for the purpose of copulation in November, a little earlier or later, according to the prospect of spring food, but seldom before the eighth or tenth of that month. The number of rams required is more or less, according to the extent of the pasture, and their own age and condition. If the ewes are not spread over an extensive tract, one ram to sixty ewes is generally sufficient. It is usually thought advisable to separate the gimmers (sheep once shorn) from the older ewes, and to send the rams to the latter eight or ten days before they are admitted to the former. Notwithstanding this precaution, which retards their lambing season till the spring is farther advanced, ewes which bring their first lamb when two years old, the common period on the best hill farms, are often very bad nurses, and in a late spring lose a great many of their lambs, unless they are put into good condition with turnip before lambing, and get early grass afterwards. This separation, and difference in the time of admitting the rams to the ewes and gimmers, should therefore be always attended to. When a farm under this description of stock has the convenience of a *few good enclosures* (as in Thirlstane farm for example), still more minute attention is paid by skilful managers. It is not sufficient that the rams are carefully selected from perhaps double the number, the ewes also are drawn out and assorted, and such a ram appropriated to each lot as possesses the properties in form or fleece in which the ewes are deficient. In other cases, the best ram and the best lots of ewes are put together. When neither of these arrangements can be adopted, owing to the want of enclosures, it is the practice to send the best rams to the ewes for a few days at first, and those of an inferior description afterwards. In every case, when the farmer employs rams of his own flock, he is careful to have a few of the best ewes covered by a well-formed and fine-woolled ram, for the purpose of obtaining a number of good ram-lambs, for preserving or improving the character of his stock.

7193. *The stock through winter*, in a mere breeding farm, consists of ewes and gimmers, which should have lambs in spring; ewe lambs or hogs; and a few young and old rams. All these are sometimes allowed to pasture promiscuously; but on the farms around Cheviot the ewes and ewe hogs are kept separate, and the ewe hogs are either put on rough pastures, which have been lightly stocked in the latter end of summer, or get a few turnips once a day, in addition to the remains of their summer pasture. The most effectual preventive of the desolating distempers to which sheep of this age are liable is turnips; and though they should never taste them afterwards, a small quantity is frequently given them during their first winter. After the rams have been separated from the ewes, they are usually indulged with the same feeding as the hogs.

7194. *The ewes, during winter*, are seldom allowed any other food than what their summer pasture affords, except that a small part of it may sometimes be but lightly eaten, and reserved as a resource

893



against severe storms. When these occur, however, as they often do in the Cheviot district, there is little dependence on any other food than hay. When the snow is so deep as completely to cover the herbage, about two stones *avoirdupois* of hay are allowed to a score of sheep daily, and it is laid down, morning and evening, in small parcels on any sheltered spot near the house, or under the shelter of *stells* or clumps of trees, on different parts of the farm.

7195. *The ewes in March*, at least the gimmers or young ewes, are commonly allowed a few turnips once a day, on farms on which there is any extent of arable land; which are either carted to their pastures, or eaten on the ground, by bringing the sheep to the turnip field through the night. A part of the field, in the latter case, is cut off by nets, or by hurdles, which enclose the sheep in the same way as if they were intended for fattening. When they are ready to drop their lambs, they are no longer kept on the turnip field, and get what turnips may be left on their pastures. But it is seldom that the turnips last so long, though it is desirable to have a few remaining to be given to the weakest ewes, or to such as have twins in a separate enclosure.

7196. *A few days before the time of lambing*, the ewes are collected for the purpose of being udder-locked. The sheep are raised upon their buttocks, their backs next to the operator, who then bends forward and plucks off the locks of wool growing on or near the udders, for the purpose of giving free access to the expected lambs. At the same time he ascertains the condition of the ewes, and marks such as do not appear to be in lamb, which may then be separated from the others. This operation is not without danger, and several premature births are usually the consequence. It is therefore not so general a practice as it was formerly, though still a common one on many, if not on most farms.

7197. *The separation of the hogs from the ewes*, where these have been allowed to pasture promiscuously, should always take place at the commencement of the lambing season, and the lowest and finest part of the pasture be exclusively appropriated to the nursing ewes. On the Cheviot hills the hogs are generally pastured apart on the coarser herbage.

7198. *The lambing season* commences with the first or second week of April, according to the time at which the rains were admitted; and such as have twins, generally lamb among the first of the flock. At this season, the most constant attention is indispensable on the part of the shepherds, both to the ewes in labour and to the newly dropped lambs. Though the Cheviot ewes are not so liable to losses in parturition as some larger breeds which are in higher condition, and though they make good nurses, unless they are very lean, and their food scanty, yet, among a large flock, there are always a number that need assistance in lambing, and in a late spring not a few who have not milk sufficient for their lambs, particularly among the gimmers or young ewes. A careful shepherd at this time always carries a bottle of milk along with him, which he drops from his own mouth into that of the lamb that may need it; brings the ewes that have little milk to a better pasture, or to turnips, and confines such as have forsaken their lambs in a small pen, or barrack as it is called, temporarily erected in some part of the farm-steading. The same confinement is necessary when it is wished to make a ewe that has lost her own lamb, nurse that of another ewe that has had twins, or that has perished in lambing, or is from any other cause incapable of rearing her lamb. The ewe, after being shut up a few hours with the strange lamb, usually admits it to the teat, and ever after treats it as her own; though sometimes a little deception is necessary, such as covering the stranger with the skin of her own lamb. At this important season, an enclosure of rich early grass, near the shepherd's cottage, is of vast advantage. Thither he carries the ewes and twins,

such as have little milk; those that have been induced to adopt another's offspring; and, generally, all that need to be frequently inspected, and are in want of better treatment than the rest of the flock. (*Supp. &c.* 178.)

7199. *Castration* is performed in the male lambs when a few days old, the ewe lambs are never spayed: mild weather is chosen, and the operation performed in a fold on small quantities at a time.

7200. *The late lambing ewes* are separated from the ewes and lambs at the end of the lambing season, and kept by themselves, that they may be more under the eye of the shepherd, than if scattered over all the pasture. It is desirable to allow them fine grass for a few weeks after lambing, that their lambs may come to be nearly equal to the rest of the flock when weaned; or if they are too late for this, that they may get ready for the butcher by the month of August, beyond which period the ewes must be much injured by suckling them. (*Supp. &c.*, art. *Agr.* 179.)

7201. *Washing*, in store-farming, is performed when the wool has risen sufficiently, which is easily known by the appearance of a new growth. The barren sheep are first brought to the washing pool. Sometimes they are hand-washed by men who stand in the pool, and have the sheep forced towards them singly; but more commonly, the Cheviot sheep, especially if the flock be numerous, are compelled to leap into the pool in a body for three or four times successively; and it is desirable that they should have room to swim a little, and come out on a green low bank on the opposite side. After being washed, the sheep are preserved as far as possible from rubbing against earthen dykes or banks, and from lying down on any dirty spot which might soil their wool. (*Supp. &c.*)

7202. *Marking*, as in general sheep-farming (7185.), takes place before the shorn sheep are turned out to pasture: they are marked, commonly with the owner's initials, by a stamp, or *boost* in provincial language, dipped in tar heated to a thin fluid state; and it is not unusual to place this mark on different parts of the body, according to the sheep's age.

7203. *The weaning of lambs* takes place when they are about three months old, sometimes sooner. When the ewes are gathered to be washed or shorn, the ewe lambs to be kept for supplying the place of the old ewes occasionally sold are stamped in the same way as the ewes. The store-lambs are sent to some clean grassy pasture for a few weeks; and where the farm does not afford this accommodation, they must be *summered*, as it is called, at a distance. Several farms near Cheviot, and on the Lammermuir hills in Berwickshire, are appropriated to this purpose, the owner of the lambs paying so much a head for six or eight weeks. In the mean time the ewe hogs, or gimmers, as they are denominated after shearing, have joined the ewe stock, and the lambs, when brought home, go to the pasture which they had occupied. Wherever they may be kept in winter, it is always desirable to allow them a few turnips, along with a full bite of coarse herbage.

7204. *The practice of milking ewes* after the separation of the lambs is still continued in a few places. This very objectionable management is generally continued for six or eight weeks. The value of the milk of each ewe for this time may not exceed from one shilling to one shilling and sixpence a head, and the sheep are injured to at least three times that amount, independent of accidents at the milking fold. The cream is separated from the ewe milk, and made into butter for smearing, and the milk itself mixed with cow milk, and converted into cheese. The most skilful store-masters, however, have either laid aside milking, unless for a few days, or have shortened the period to two or three weeks.

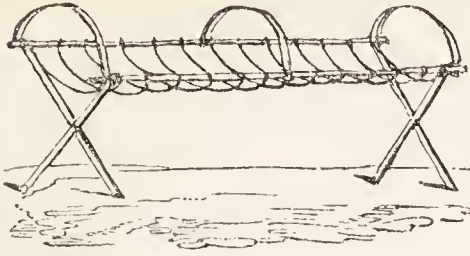
7205. *The selection of the cronos or old ewes* to be sold generally takes place in September or October, when they are sold to the feeder, and replaced by lambs of the current year. On the lower hills, ewes are generally disposed of after having lambed three seasons, or under four and a half years of age. In some situations they are kept on till a year older; but when they are purchased, as they usually are, to be kept another year on lower grounds, it is commonly for the interest of the store-farmer to sell them when still in their full vigour. Skilful managers do not content themselves with drafting them merely according to age; for as there is no disadvantage in keeping a few of the best another year, they take this opportunity of getting rid of such of the flock of other ages as are not of good shapes, or are otherwise objectionable. As soon as the ewes to be disposed of are drawn from the flock, they are kept by themselves on better pasture, if the circumstances of the farm will admit of it. Sometimes they are carried on till they are fattened, and turnips are often purchased for them at a distance. When this is the case, it is not thought advisable to keep them longer than till between Christmas and Candlemas, as an old ewe does not improve like a wether in the spring months. (*Supp. &c.*)

7206. *The salving or smearing of sheep* is an operation scarcely known in England, and not practised by the Welsh: some store-farmers in the milder districts of the northern counties consider it unnecessary, but in all very cold situations it is still employed. The object of this operation is to destroy vermin, to prevent cutaneous diseases, and to promote the warmth and comfort of the animal during the storms of the ensuing winter. It is not necessary with sheep kept on low grounds, and well fed during winter, and it may occasionally be omitted for one season, particularly with old sheep, without material injury; but notwithstanding the ridicule that speculative writers have attempted to throw upon the practice, it is almost universally considered necessary and beneficial on high exposed situations, by the store-farmers of the border hills. Smear'd wool does not sell so high as white wool, but the greater weight of the former more than compensates for the difference in price. (*General Report of Scotland*, vol. iii.) The season of salving or smearing is usually towards the end of October or beginning of November, before the rams are sent to the ewes. The most common materials are butter and tar, mixed in different proportions; a greater proportion of tar being employed for the hogs or young sheep than for the older ones. The proportions are also different on almost every farm, and more tar is thought to be necessary, according to their greater elevation and exposure. In Roxburghshire, some mix two gallons of tar with thirty-six pounds of butter, as a sufficient allowance for three score of sheep; but for the same number it is more common to allot only one stone (twenty-four pounds) of butter to two gallons of tar. (*Roxburghshire Report*, p. 155). A common proportion of late has been about fourteen pounds of butter to two Scotch pints of tar (nearly $3\frac{1}{2}$ quarts English wine measure), for ewes, and eleven pounds to the same quantity of tar for hogs. This mixture should smear from twenty to twenty-five of each, which is the number one man can do in a day. The expense, according to present prices, will be about nine-pence for each sheep: other articles, such as oil, palm-grease, tallow, &c., have been recommended in place of butter; but none of them are in general use, and the only addition that is approved of is a little butter-milk. The butter is slowly melted and poured upon the tar, and the mixture is constantly stirred till it becomes cool enough for use. The wool is accurately parted into rows from the head to the tail of the animal, and the salve is carefully spread upon the skin with the point of the finger at the bottom of each row. (*Supp. En. Brit.* art. *Agr.* 180.) The practice of salving has undergone a change within these four years, and is not so general now as formerly, the low price of smear'd wool having forced the store-masters to try other ingredients than tar. In the *Farmer's Magazine*, vol. xxv. are some notices of these experiments on smearing; which have not, however, been so long in use as to afford certain results. The object at present is as far as possible to dispense with tar, by which the wool is rendered unfit for certain sorts of manufacture.

7207. *The care of sheep during storms* is a business requiring constant attention. In storms of wind and rain, or what are called *black storms* by the shepherds, the sheep will, in a great measure, take care of themselves, by pasturing in situations naturally sheltered. All that is required is to remove any of the more delicate into a covered fold or sheep-house; though such conveniencies are seldom to be found on mountain farms. But in a storm of snow the natural shelter to which the sheep have recourse becomes the great receptacle of drift, and the harbinger of death to the flock. It is in such situations that Captain Napier purposes to place his stalls, or circular folds (*fig.* 893. ○), into which the sheep should be driven, or will naturally enter on the commencement of the storm. The round form for these stalls or folds is decidedly preferable to any figure with straight lines, as these invariably harbour drift. Where no

artificial shelter is provided immense losses sometimes take place on mountain farms. The sheep are buried many feet deep in the snow; and though the shepherd, with such assistants as he can procure, armed with poles and spades, and aided by the sagacity of his dog, may dig out a few, yet the greater number perish. While the sheep remain in artificial shelters of any kind they must of course be fed; and the only convenient food in such cases is hay, straw, or dried spray (the latter seldom resorted to in this country), which should be put into baskets, or racks. (*fig. 894.*) The Ryeland breed of sheep in Herefordshire, and some of the flocks in the Highlands of Scotland, are put under cover nightly throughout the year: a practice which has probably originated in security, and been continued as matter of convenience and habit.

894



SECT. V. *Folding of Sheep.*

7208. *Cotting or folding* is a practice more or less extensively followed with particular breeds and in particular districts, but now generally on the decline.

7209. *It was formerly thought to be indispensably necessary* to the success of the farmer in different districts; but of late a different opinion has prevailed, except in particular cases, and it is considered as merely enriching one field at the expense of another. The practice may, however, be beneficial where there are downs, heaths, or commons. Folding has been chiefly confined to England, and a small part of Wales and Ireland. The object is to enrich the arable land; but as this is done at the expense of the pasture, it is truly, as Bakewell expressed it, "robbing Peter to pay Paul."

7210. *The sheep best adapted to the fold* are those of the more active, short-woolled varieties, such as the Norfolk, Wiltshire, and South Down breeds; the heavy long-woolled kinds being less hardy, and some of them, as the Leicesters, much too valuable for a mode of treatment that converts them into dung carriers. The following calculation by Marshal will show, that though, in open lands, the practice may be in some cases tolerated on the ground of conveniency or expediency, it can possess no recommendation as a profitable mode of management in other circumstances.

7211. *This morning* (September 22. 1780), measured a sheep-fold, set out for six hundred sheep, consisting of ewes, wedders, and grown lambs. It measures eight by five and a half rods, which is somewhat more than seven rods to one hundred, or two yards to a sheep.

7212. *August 29. 1781.* Last autumn made an accurate experiment, on a large scale, with different manures for wheat, on a sandy loam, summer fallowed. Part of an eighteen acre piece was manured with fifteen or sixteen loads of tolerably good farm-yard dung an acre; part with three chaldrons of lime an acre; the rest folded upon with sheep twice; the first time at the rate of six hundred sheep to a quarter of an acre (as in first minute), the second time thinner. In winter and spring, the dung kept the lead; and now, at harvest, it has produced the greatest burden of straw. The sheep-fold kept a steady pace from seed-time to harvest, and is now evidently the best corned, and the cleanest crop. The lime, in winter and spring, made a poor appearance, but after some showers in summer it flourished much, and is now a tolerable crop, not less, I apprehend, than three quarters of an acre.

7213. *From these data* the value of a sheep-fold, in this case, may be calculated. It appears from the first minute, that one hundred sheep manured seven square rods daily. But the second folding was thinner; suppose nine rods, this is, on a par of the two foldings, eight rods a day each folding. The dung could not be worth less than half a crown a load, and the carriage and spreading ten shillings an acre; together fifty shillings an acre; which quantity of land the hundred sheep teathed twice in forty days. Supposing them to be folded the year round, they would, at this rate, fold nine acres annually; which, at fifty shillings an acre, is twenty-two pounds ten shillings a hundred, or four shillings and sixpence a head. In some parts of the island, the same quantity of dung would be worth five pounds an acre, which would raise the value of the teathe to nine shillings a head; which, at two-pence a head a week, is more than the whole year's keep of the sheep. It does not follow, however, that all lands would have received equal benefit with the piece in consideration; which, perhaps, had not been folded upon for many years, perhaps never before; and sheep folds, like other manures, may become less efficacious the longer it is used on a given piece of land. (*Marshal's Rural Economy of Norfolk*, vol. ii. p. 29.)

7214. *To fold on land in tillage all the year* is nearly impracticable; and where it could be done, the manure would be greatly diminished in value from rain and snow, to say nothing of the injury to the sheep themselves. So that the estimate of four shillings and sixpence, or nine shillings a head, is evidently in the extreme.

7215. *According to Arthur Young* (*Farmer's Calendar*), the same land will maintain one fourth more stock when the animals are allowed to depasture at liberty, than when confined during the night in folds. The injury to the stock themselves, though it is not easy to mention its precise amount with any degree of accuracy, cannot well be doubted, at least in the case of the larger and less active breeds, when it is considered that they are driven, twice a day, sometimes for a distance of two, or even three miles, and that their hours of feeding and rest are, in a great measure, controlled by the shepherd and his boy. When they are kept in numerous parcels, it is not only driving to and from the fold that affects them, but they are in fact driving about in a sort of march all day long, when the strongest have too great an advantage, and the flock divides into the head and tail of it, by which means one part of them must trample the food to be eaten by another. All this points the very reverse of their remaining perfectly quiet in small parcels.

7216. *The result of Parkinson's experience* is, "that were the pasture sheep of Lincolnshire to be got into a fold once a week, and only caught one by one, and put out again immediately, it would prevent their becoming fat." (*Parkinson on Live Stock*, vol. i. p. 367.) The only sort of folding ever adopted to any extent by the best breeders is on turnips, clovers, tares, and other rich food, where the sheep feed at their case, and manure the land at the same time.

7217. *Folding in littered yards* is described by Dickson (*Complete Farmer*, art. *Sheep*) as combining all the advantages of folding on arable lands without any of its disadvantages. By this practice the sheep are confined at night in a yard well and regularly littered with straw, stubble, or fern; by which means the flock is said to be kept warm and healthy in bad seasons, and at the same time a surprising quantity of manure accumulated. A great improvement on this method, it is said, would be, giving the sheep all their food (except their pasture) in such yard, viz. hay and turnips: for which purpose they may be brought up not only at night, but also at noon, to be baited; but if their pasture be at a distance, they should then, instead of baiting at noon, come to the yard earlier in the evening, and go out later in the morning. This is a practice, he says, that cannot be too much recommended; for so warm a lodging is a great matter to young lambs, and will tend much to forward their growth: the sheep will also be kept in good health; and, what is a point of consequence to all farms, the quantity of dung raised will be very great. If this method is pursued through the months of December, January, February, March, and April, with plenty of litter, one hundred sheep will make a dunghill of at least sixty loads of excellent stuff, which will amply manure two acres of land; whereas one hundred sheep folded (supposing the grass dry enough) will not, in that time, equally manure an acre.

7218. *Our opinion of this sort of folding*, so warmly recommended by Sir J. Sinclair and A. Young, in the husbandry of Scotland, coincides with that of a very superior judge, who says, "that such a method may be advantageous in particular cases, it would be rash to deny; but generally it is not advisable, either on account of the sheep, or any alleged advantage from the manure they make. As to the sheep, this driving and confinement, especially in summer, would be just as hurtful as folding them in the common way, and it has been found that their wool was much injured by the broken litter mixing with the fleece in a manner not to be easily separated; besides, now that it is the great object of every skilful breeder to accelerate the maturity of his sheep, as well as other live stock; among other means, by leaving them to feed at their ease, and if circumstances permit, in small parcels; such a practice as this can never be admissible in their management; and with regard to manure, there can be no difficulty in converting into it any quantity of straw, stubble, and fern, by cattle fed in fold-yards, on green herbage in summer, and turnips, or other succulent food, in winter; while the soil, especially if it be of a light porous quality, is greatly benefited both by the dung and treading of sheep, allowed to consume the remainder of both sorts of food on the ground. It is true, that the dung of sheep has been generally supposed to be more valuable than that of cattle, but accurate experiments have not been made to determine the difference in this respect, among these and other polygastric animals. The greater improvement of pastures by sheep is probably owing as much to their mode of feeding, as to the richer quality of their dung." (*Sup. E. Brit. art. Agr.*)

SECT. VI. *Of Fattening Sheep and Lambs.*

7219. *The subject of fattening sheep* may be considered in regard to the age at which fattening is commenced, the kind of food, and the manner of supplying it.

7220. *The age* at which sheep are fattened depends upon the breed, some breeds, such as the Leicester, maturing at an earlier age than others, under the same circumstances; and also in the abundance and quality of the food on which they are reared; a disposition to early obesity, as well as a gradual tendency towards that form which indicates a propensity to fatten, being materially promoted by rich food, while the young animals are yet in a growing state. On good land, the Leicester wethers are very generally brought to a profitable state of fatness before they are eighteen months old, and are seldom kept for fattening beyond the age of two years: the Highland breeds, on the other hand, though prepared, by means of turnips, a year at least sooner than they could be in former times, usually go to the shambles when from three to four years old. The ewes of the first description are commonly fattened after having brought lambs for three seasons, that is, after they have completed their fourth year, and those of the small breeds, at from five to seven years of age, according to circumstances. (*Sup. E. Brit. art. Agr.*)

7221. *The kinds of food* on which sheep are fattened are good pastures, permanent or temporary; herbage crops, as clovers, tares, &c.; turnips and other roots; and linseed cake, grains, or other edible refuse of the oil manufactory, brewery, and distillery.

7222. *The mode of feeding* on rich pastures, herbage, and turnips has already been described when treating of these crops; and it remains only to notice the modes of using grains and oil cake. These, and also bran, oats, peas, and other grains and meals, whether given in winter or summer, should always be accompanied with pasture or dry food of some sort, especially hay. All food of this sort should be given in moveable troughs, divided in the middle, so that the sheep may feed on each side, with a sloping roof over them, so as to cover the sheep's heads and necks while feeding, as wet is not only prejudicial to the sheep but spoils the food. A rack for hay, fixed over the trough, might probably be made to answer in this intention, while it would be very convenient for holding that material and preventing waste. The whole should be fixed on wheels and made to stand steady, and a sufficient number for the quantity of sheep be always in readiness. In the fattening of wethers the use of barley meal, with grass or some other sort of green food, has likewise been found highly beneficial; and, when it can be procured at a reasonable rate, should not be neglected, as it is quick in rendering them fat, and the mutton is excellent. A pound of oil-cake or of meal per day, with hay or turnips, for each crone or wether, is reckoned a fair allowance in Lincolnshire. In the report of that county several instances of oil-cake feeding are given, by which it appears that that sort of food fattens in a shorter time than any other, is the most suitable food for fattening old sheep, and a rapid promoter of the growth of the wool.

7223. *In fattening sheep* as well as other animals, it should be made a rule never to allow them to lose flesh, from the earliest age till they are sent to the butcher. It is found of much advantage, with a view to speedy fattening as well as to the economy of food, to separate a flock into divisions, corresponding with its different ages, and the purpose of the owner as to the time of carrying them to market; and the change from the food of store to fattening stock, from that which is barely capable of supporting the condition which they have already attained to that which is adapted to their speedy improvement in fattening, ought to be gradual and progressive. Thus very lean sheep are never, in good management, put to full turnips in winter, nor to rich pastures in summer: they are prepared for turnips in good grass land; often on the after-grass of mown grounds and kept on second year's leys, and afterwards a moderate allowance of turnips if they are fattened on pastures. It is a common practice, in the instance of the Leicesters, to keep all that are not meant for breeding always in a state of fatness, and after full feeding on turnips through winter and spring, to finish them on the first year's clover early in summer, when the prices of meat are usually the highest.

7224. *The fattening of lambs* during summer requires nothing more than keeping their mothers and them on the richest and best pasturage, and supplying such artificial food as the situation, season, or other circumstances may require: but the fattening of lambs during winter and spring requires attention to three things; the breed, or if any breed be used indifferently, the period of dropping, the lamb-house, and the feeding.

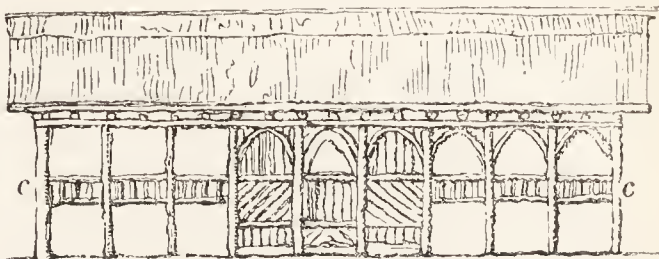
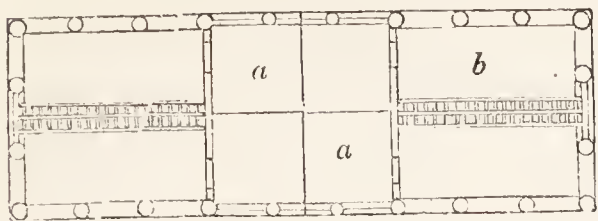
7225. *With respect to the breed*, as the sheep will take the ram at any season, any variety may be so managed as to drop their lambs at any period of the year; but it is found by experience, that the Dorsetshire sheep is easiest made to yearn, and therefore this is the sort generally employed in Middlesex for rearing what is called house-lamb for the metropolis. The selection of the rams for breeding the lambs to be house-fed is, according to Middleton, founded on the following circumstances:—The sucklers, salesmen, and butchers of London are aware that such lambs as have sharp barbs on the inside of their lips are certainly of a deep colour after being butchered, and that all those whose barbs are naturally blunt do as certainly produce fair meat. This knowledge has been the occasion of many lambs of the latter kind being kept for rams, and sent into Dorsetshire expressly for the purpose of improving the colour of the flesh of house-lambs: the issue of such rams can generally be warranted fair, and such meat always sells at a higher price; hence arose the mistaken notion that Middlesex rams were necessary to procure house-lambs.

7226. *A lamb-house* may be any close shed, cow-house, or other spare house, or, even on a small scale, a roomy pigsty. But they are built on purpose by the extensive dealers in this article; and one to suckle from one hundred and sixty to one hundred and eighty lambs at a time should be seventy feet long and eighteen feet broad, with three coops of different sizes at each end, so constructed as to divide the lambs

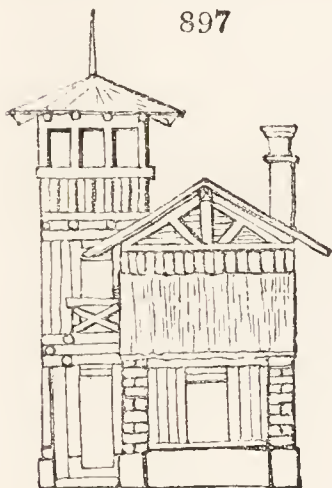
according to their ages. A plan of a sheep-house, combining also a lamb-house, is given by Kraft in his *Rustic Designs*. It is wholly built of unbarked spars or young fir-trees. The plan (*fig. 895.*) contains four close apartments with doors for the lambs (*a*), and four others with racks for the sheep (*b*). The elevation

895

896



(*fig. 895.*) shows a gallery (*c*), which surrounds the building, and is used as a passage for viewing the sheep, handling them with the crook, and at night for the perambulations of a watch-dog. The roof being twenty feet from the floor, the interior is abundantly airy, which for sheep is an important object. Another design in the same work (*fig. 897.*) is accompanied by an elegant Indian watch-tower, with apartments therein for the shepherd.



897

7227. *The economy of the suckling-house* is as follows:—The sheep which begin to lamb about Michaelmas are kept in the close during the day, and in the house during the night, until they have produced twenty or thirty lambs. These lambs are then put into a lamb-house, which is kept constantly well littered with clean wheat straw; and chalk, both in lump and in powder, is provided for them to lick, in order to prevent looseness, and thereby preserve the lambs in health. As a prevention against gnawing the boards or eating each other's wool, a little wheat straw is placed, with the ears downwards, in a rack within their reach, with which they amuse themselves, and of which they eat a small quantity. In this house they are kept, with great care and attention, until fit for the butcher.

7228. *The mothers of the lambs* are turned, every night at eight o'clock, into the lamb-house to their offspring. At six o'clock in the morning these mothers are separated from their lambs, and turned into the pastures; and at eight o'clock such ewes as have lost their own lambs, and those ewes whose lambs are sold, are brought in and held by the head till the lambs by turns suck them clean: they are then turned into the pasture, and at twelve o'clock the mothers of the lambs are driven from the pasture into the lamb-house for an hour, in the course of which time each lamb is suckled by its mother. At four o'clock all the ewes that have not lambs of their own are again brought to the lamb-house and held for the lambs to suck; and at eight the mothers of the lambs are brought to them for the night.

7229. *This method of suckling* is continued all the year. The breeders select such of the lambs as become fat enough, and of proper age (about eight weeks old), for slaughter, and send them to markets during December and three or four succeeding months, at prices which vary from one guinea to four, and the rest of the year at about two guineas each. This is severe work for the ewes, and some of them die under excess of exhaustion. However, care is taken that they have plenty of food; for when green food (*viz.* turnips, cole, rye, tares, clover, &c.) begins to fail, brewer's grains are given them in troughs, and second-crop hay in racks, as well to support the ewes as to supply the lambs with plenty of milk; for if that should not be abundant, the lambs would become stunted, in which case no food could fatten them. (*Middlesex Report*, p. 355.)

SECT. VII. *Probable Improvement to be derived from Crosses of the Merino Breed of Sheep.*

7230. *The Merino*, or Spanish variety of the *Ovis Aries*, is supposed by Rozier and other French writers to have been originally imported from Africa to Spain. It is, however, at least as probable that they are indigenous to that country, or, if originally imported, that they have become modified to what they are by the soil and climate.

7231. *Merinos first attracted attention in this country* in 1764, in consequence of the reports of travellers, and a letter by Don John Bowley to Peter Collinson, published in the *Gentleman's Magazine* for that year. A few were imported in 1788, and more in 1791, and placed on the king's farm at Windsor, under the care of Sir Joseph Banks, who was then constituted his Majesty's shepherd. The first sale of stock was made in 1800; and from these, a flock imported from Spain in 1801 by Lord Somerville, and some other importations by different persons subsequently, have sprung all the Merinos and Merino rams in the empire. Since that period, a number of eminent breeders and scientific agriculturists have cultivated this breed both alone and by crossing, but especially Dr. Parry and Lord Somerville; and though the utility which its introduction may ultimately prove to the country can by no means be estimated at present, that it has already done much good by directing the public attention to the subject there can be no doubt; and many are of opinion, that by it the fleeces of our short-woolled sheep may be so improved as to render them fit substitutes for imported Spanish wool.

7232. *Dr. Parry's experiments* with the Merino breed were begun nearly at the same time with the king's. His farm was elevated, exposed, and unfit for any other purpose than breeding; and he fixed on the Ryeland breed, as one of the finest woolled varieties of British sheep, for crossing with Merino rams. His only object was the improvement of the fleece.

7233. *The effect of the fourth cross of the Merino ram*, according to the opinion of sheep cultivators on the Continent, on any breed of ewes, however coarse and long in the fleece, will be to give progeny with short wool equal to the Spanish. Of the truth of this proposition, however, Dr. Parry justly expresses some doubts, derived from his own experience and that of others. But it is certain, he adds, that one cross more will, in most cases, effect the desired purpose. If we suppose, he says, the result of the admixture of the blood of the Merino ram to be always in an exact arithmetical proportion, and state the native blood in the ewe as 64; then the first cross would give $\frac{32}{64}$ of the Merino; the second $\frac{48}{64}$; the third $\frac{56}{64}$; the fourth $\frac{60}{64}$; the fifth $\frac{62}{64}$; the sixth $\frac{63}{64}$, and so on. In other words, the first cross would leave thirty-two parts in sixty-four, or half of the English quality; the second sixteen parts, or one fourth; the third eight parts, or one eighth; the fourth four parts, or one sixteenth; the fifth two parts, or one thirty-second; the sixth one part, or one sixty-fourth, and so on. Now, if the filaments of the Wiltshire, or any other coarse wool, be in diameter double that of the Ryeland, it is obvious, that, according to the above statement, it would require exactly one cross more to bring the hybrid wool of the former to the same fineness as that of the latter. This, he believes, very exactly corresponds with the fact. The dif-

ference between one eighth and one sixteenth is very considerable, and must certainly be easily perceived, both by a good microscope, and in the cloth which is manufactured from such wool. In the latter method, he adds, "it certainly has been perceived; but I have hitherto had no opportunity of trying the difference by the former. The fifth cross, as I have before observed, brings the Merino-Wilts wool to the same standard as the fourth of the Merino Ryeland." (*Com. to the Board of Agr.* vol. v. p. 438.)

7234. *In the lambing season*, the Ryeland breed are usually cotted, because the new-born lambs are very thinly covered with wool. As January was considered the best lambing season for the produce of the cross, Dr. Parry found cotting was doubly necessary. Every night the flock were well sheltered; and they were allowed, in addition to the pasture which they could pick up in the day-time, linseed jelly, ground oil-cake, or grains, cabbages, rouen, winter and spring vetches, and tares. Salt, he says, I never gave to my flock but once, and that in the following way:—A small field of lattermath, cut in September, had been so often wetted, that I despaired of its ever being eaten. While it was putting into the rick, I strewed some salt between the layers; the consequence was, that cows and sheep greedily devoured it, scarcely leaving a single blade. (*Com. to the Board of Agr.* vol. v. p. 505.)

7235. *The shearing of the sheep* was performed in the second week of June, and of the lambs at the end of July. The finer fleeced lambs need not be shorn till the second season. Washing previously to shearing Dr. Parry disapproves of; because the fleece is so thick, that when thoroughly soaked with water, it is very long in drying; and if the weather prove wet and cold, the sheep are evidently much incommoded; he therefore recommends cleansing the wool, after being shorn, as in Spain.

7236. *The produce of wool*, considered as the result of Dr. Parry's well conducted experiments, was found to be 14 lbs. 14 oz. per acre, which at 3s. per lb. in the yolk throughout the fleece gives 2l. 4s. 7½d. per acre on land certainly not worth on an average 26s. (*See Comm. to the B. of Agriculture*, vol. v.)

7237. *Lord Somerville's experiments* may be considered as of equal, if not more importance than these of Dr. Parry. His Lordship tried crosses with several short-woolled breeds, but was most successful with the South Downs and Ryelands. Morris Birkbeck, a professional farmer of the first order, found that the fleeces of the first cross between Merinos and South Downs, washed, are to the parent South Downs as six to five in weight, and as three to two in value per pound, and believes that the improvement of the wool may go on, without detriment to the carcass, until we shall obtain a breed of sheep with Spanish fleeces and English constitutions; but this must be the result of careful and judicious selection.

7238. *Merino flocks are now established in most districts* of the empire, and but few years can elapse before their value to the farmer and the country be practically ascertained and evinced. (*See Sir J. Banks in Annals of Agriculture, Com. to B. of Agr. Bath Society's Papers, Dublin Society's Transactions, The Farmer's Magazine, Farmer's Journal. Lord Somerville's and Dr. Parry's Tracts on Wool and Merinos, and various other works.*)

SECT. VIII. *Anatomy and Physiology of Sheep.*

7239. *The general structure of the sheep* resembles that of the ox very intimately. Sheep however, like the ox, experience considerable variations in size, form, and qualities; resulting from the physical and moral agencies which they become exposed to, under various climates: and also, as whether fostered by cultivation, or left to the natural operations of nature around them. These circumstances have operated on even the bony base of the machine, as we see in the formations of the three-horned breed (*Ovis polycérata Lin.*), natives of the north; in the spiral-horned (*O. Strepíceros Lin.*), which inhabit Wallachia; and the long-horned (*Càpra A'mmon Lin.*), which are found in the countries bordering the Mediterranean: and which have been thought to be the parents of the present cultivated British sheep.

7240. *Cultivation weakens the otherwise inherent aptitude* to retain the original stamp of nature; and we find, therefore, that by these means, the original form of the sheep has submitted to vast alterations. We see some of them wholly without horns; we also find that the bony structure is otherwise subjected to our command, by becoming much more slender, though more compact. Accidents are also laid hold on by man to produce particular forms: thus a breed has been cultivated in America, called the ancon or otter breed, remarkable for crooked and deformed legs; which, by continued breeding from specimens that presented this originally accidental deformity, is become now a fixed and permanent breed, valuable for their incapacity to wander or climb. (*Dwight.*) The dunky, or wry-faced breed, is another instance of accidental deformity cultivated into a permanent variety: as the monstrous rump of the Tartarian sheep, and the over-grown tails of some breeds in Turkey, and the Cape of Good Hope, are similar instances in the softer parts of the body.

7241. *The skeleton of the sheep* presents an assemblage of bones, which bears a general resemblance to that of the ox in number and direction. Like him, the head naturally is surmounted by horns springing from the frontal bones. Like him, his frontal sinuses are large and open, and thus liable to the entrance of insects. The skull bones arc wide and extended; his orbits are more lateral than central; and his facial angle is about thirty degrees. His vertebral column is the same as the ox, and his ribs also. The extremities descend on the same construction, ending in a divided hoof.

7242. *The visceral and soft parts* are but little dissimilar likewise. His brain is as one two-hundredth to the whole body; and his cerebellum to the brain generally, as one to five. The pigment of the eye is of a pale yellowish green, varying occasionally to a blue. The viscera of the chest correspond with the ox; and those of the belly also, the stomachs being the same, and the economy of rumination not differing. The liver, pàncreas, and spleen are similar. The pennis is taper, vesiculæ seminàles wanting, and prostrates two.

7243. *The wool of the sheep* is but a crisped hair; and indeed in some foreign varieties, the outer covering is of long hair like that of oxen; while in others, the hair and wool are mixed.

SECT. IX. *Diseases of Sheep.*

7244. *The diseases of sheep* are numerous; for these animals are now so highly cultivated that they may be regarded in some respects as artificial machines: and thus, as a natural consequence, they are subjected to a variety of artificial defects or maladies.

7245. *The rot is a popular term* among shepherds, and includes within its range diseases widely different. We shall not, therefore, follow the custom of treating the different rots of sheep together; but we shall allow them to fall in their natural order, according to the plan pursued with the diseases of oxen.

7246. *The inflammatory and putrid fever*, popularly known by the names *higham striking*, or *blood striking*, does not differ materially from the same disease in oxen and cows; and is in sheep also sometimes epidemic; appearing by panting, dulness, watery mucus from the nose and eyes; and great redness of all such parts as are usually white.

7247. *The red water*. The inflammatory fever sometimes resolves itself into an universal secretion of serum throughout all the cavities; in which case, after a few days, the lymph tinged with blood will come

away from the nose and mouth in large quantities. Sometimes after death the bloody serum is found suffused throughout the skin as in the blood striking of skins.

7248. *The claveau or sheep pox* is also another variety of this disease, in which it takes on a pustular form. About the third day small variolæ appear: sometimes they are rather blotches than pustules. The weakness is usually extreme, and the putridity great. This form of the disease is seldom seen with us; but is still known on the Continent, where the pastures are very poor and low, and the general keep meagre.

7249. *The treatment* of all these in nowise differs from that directed under the inflammatory putrid fever of the ox; the doses of medicine being about a third of what is directed for them.

7250. *Malignant epidemic or murrain.* Sometimes an epidemic prevails, which greatly resembles the murrain of oxen: in appearances, termination, and treatment, it resembles the malignant epidemic of oxen. (6943.)

7251. *Peripneumonia or inflamed lungs, rising of the lights, glanderous rot, hosc, &c.* These terms are all modifications of an inflamed state of the viscera of the chest, caught by undue exposure, bad pasturage, and often from over-driving. The cough, the tremblings, the redness of the eyes and nostrils, and the distillation of a fluid from them, with the heavings and hot breath, are all similar to those which characterise the pneumonia or rising of the lights in oxen. We remember to have seen the disease strongly marked in the February of 1808, on a farm in the neighbourhood of Streatham; where eleven sheep were attacked almost together, after a very stormy night. They were first affected with a loss of appetite; next with a fixed staid look, which was common to every one. After this, they reeled about, fell backwards, and became convulsed. When seen, five were already dead, whose internal appearances fully confirmed the nature of the disease. The rest recovered by bleeding and drenching, with drenches composed of nitre and tartar emetic. Sometimes the symptoms of pneumonia do not kill immediately, but degenerate into an ulceration of the lungs; which is then called the *glanderous rot*. This stage is always fatal: the others may, by early attention, be combated by judicious treatment, as detailed under the same disease in oxen.

7252. *A chronic cough* in sheep, when not symptomatic of rot, is always cured by a change of pasturage, particularly into a salt marsh.

7253. *Inflammation of the stomach* occurs from various causes. A common one arises from eating noxious vegetables; and produces the affections termed *tremblings*. It also produces the *grass ill* in lambs; which latter is always accompanied with black, fetid fæces, and is readily removed by an ounce of castor oil; while the former usually yields to half an ounce of oil of turpentine, beaten up with the yolk of an egg. Some herbs (as *A'tropa Belladonna*) when eaten produce spasmodic affections, which are called by shepherds the *leaping ill*: in such cases, the watery solution of aloes (*Vet. Pharm.* 6585.) in doses of two or three ounces is useful. Daffy's elixir we have also known to be given with good effect.

7254. *The hove, blast, or wind colic.* Sheep are as liable to be distended with an enormous collection within the maw as oxen. An instrument, similar to that invented by Dr. Monro, is also made for them; and when not relieved by these means, the same remedies are applicable as are directed for oxen. (6953.)

7255. *A wind colic* will also sometimes affect sheep more from the quality than the quantity of what they eat; it is best relieved by an ounce of castor or salad oil with an ounce of gin.

7256. *Inflamed liver, blood rot, or hot yellows,* are liver affections, arising from fever settling in that organ; or from obstructed bile irritating it. Sometimes there are great marks of fever; and at others more of putridity; according to which, treat as may be gathered from ox pathology.

7257. *Jaundice* also now and then occurs, when refer to that disease in oxen. (6962.)

7258. *Dysentery, gall scour, braxy,* are all affections brought on by sudden changes of temperature, or of undue moisture acting with cold pasturage. It is often seen in sultry autumns; and, by a judicious observer, has been said to be peculiarly frequent in hogs or sheep of one year. Like other dysenteries it is frequent in sultry autumns. The above authority recommends, when its origin may be supposed to arise from a previous costive state, to remove the affected (as is practised by the store-masters of Scotland) into turnips. The general medical treatment does not differ from ox braxy. (6961.)

7259. *Scouring* is the diarrhœa of sheep, and in very hot weather soon carries them off. It should be early attended to, by abstracting the affected, and housing them. The *treatment* is seen under diarrhœa of oxen (6960.), which it closely resembles.

7260. *Pinning, tag-belt, break-share.* The two former are only the adhesion of the tail to the wool, and the excoriation brought on by diarrhœa; the latter is the diarrhœa itself, known to some by this term.

7261. *The rot in sheep* is also called *great rot*, and *hydropic rot*, &c.; but it is more popularly known by the single term of *rot*. Many causes have been assigned for it, as the *Fasciola hepática*, or fluke worm; some particular plants eaten as food; ground eating; snails, and other ingesta; but, as most of the supposed deleterious herbs have been tried by way of experiment, and have failed to produce the disease, so it is attributable to some other cause. Neither is there satisfactory reason to suppose that the fluke worm is the original cause of it, but a consequence, since we know that the biliary vessels of other animals, as horses, asses, rats, &c., often have them: and above all, because that they are not always present in the rotted subject. From long experience, and the almost invariable effect produced by a humid state of atmosphere, soil, and product, we are warranted in concluding these are the actual and immediate agents: perhaps the saturated food itself is sufficient to do it. The morning dew has been supposed equal to it. Bakewell, when his sheep were past service, used to rot them purposely, that they might not pass into other hands. This he always readily did by overflowing his pastures. But great differences of opinion exist as to the quantity, form, and varieties of moisture, productive of this fatal disease. It is said that land on which water flows, but does not stagnate, will not rot, however moist: but this is contradicted by the experience of Bakewell, who used merely to flood his lands a few times only to rot his sheep. It is also said that they are safe from rot on Irish bogs, salt marshes, and spring-flooded meadows, which experience seems to verify. It is also said that the very hay made from unsound land will rot; but this wants confirmation. When salt marshes are found injurious, it is only in years when the rain has saturated or rather super-saturated such marshes. That putrid exhalations unaccompanied with moisture can occasion rot wants confirmation also; for these commonly go together, and it is difficult to separate their effects. It is not, perhaps, the actual quantity of water immediately received by land, but the capacity of that land to retain the moisture, which makes it particularly of a rotting quality.

7262. *The signs of rottenness* are sufficiently familiar to persons about sheep. They first lose flesh, and what remains is flabby and pale; they also lose their vivacity. The naked parts, as the lips, tongue, &c., look livid, and are alternately hot and cold in the advanced stages. The eyes look sad and glassy, the breath is fetid, the urine small in quantity and high-coloured; and the bowels are at one time costive, and at another affected with a black purging. The pelt will come off on the slightest pull in almost all cases. The disease has different degrees of rapidity, but is always fatal at last. This difference in degree occasions some rotted sheep to thrive well under its progress to a certain stage, when they suddenly fall off, and the disease pursues the same course with the rest. Some graziers know this crisis of declension, as it has been called, and kill their sheep for market in the immediate nick of time with no loss. In these cases, no signs of the disease are to be traced by ordinary inspectors, but the existence of the flukes, and still more, a certain state of liver and of its secretions, are characteristic marks to the wary and experienced.

7263. *The treatment of rot* is seldom successful unless when it is early commenced, or when of a mild nature; a total change of food is the first indication, and of that to a dry wholesome kind: all the farina are good, as the meals of wheat, barley, oats, peas, beans, &c. Carrots have done good mixed with these:

broom, burnet, elder, and melilot, as diuretics, have also been recommended; but it is necessary to observe, that there is seldom any ventral effusion but in the latter stages of the complaint. As long as the liver is not wholly disorganised, the cure may be hoped by a simple removal of the cause, which has been shown to be a variable temperature, with excessive moisture of pasturage, which may also be aided by such remedies as assist the action of the biliary system; salt acts in this way, and thus salt mashes are good; salt may also be given in the water. Salt appears the principal ingredient in Flesh's patent restorative for sheep; for it states it to be composed of turpentine, sal ammoniac, turmeric, quicksilver, brimstone, salt, opium, alkanet root, bark, antiimony, camphor, and distilled water; but of this medley none of the articles can be in sufficient quantity to prove useful but the salt. In the more advanced stages of the disease, when the liver has become materially affected, it is prudent to rub the belly of each sheep with half a drachm of mercurial ointment every other day for a week: give also the following, every morning: — Watery tincture of aloes, half an ounce; decoction of willow bark, four ounces; nitric acid, twenty-five drops.

7264. *The pelt rot, hunger rot, or naked disease*, is a variety of the former, but with this difference, that whereas the liver in the hydropic rot is principally affected; in this the whole of the chylopoietic viscera are injured; the mesenteric glands are always swollen and obstructed, and from thence arises the emaciation and unhealthy state of all the secretions, by which the wool becomes incapable of receiving nutriment, and falls off, leaving the body bare, and in the last stages the teeth and horns also loosen. Indifferent, unhealthy keep is a very common cause of this malady, and a contrary course of feeding is the best remedy when the disease has not gone on too long.

7265. *The scab, shab, ray, or rubbers*, are sometimes erysipelatous eruptions, and sometimes they are psoric or mangy ones. In the former instance they are universal and very red, occasioning a great heat and itching, and are thence called the *rubbers*: in such cases, nitre administered quickly relieves, with change of food. The eruptive scab is seldom cured without an external application; either of those directed for mange, lowered to half the strength, will relieve it at once. (See *Vet. Pharm.*)

7266. *Foot rot*. Sheep have a secretory outlet between the claws peculiar to them, which is liable to become obstructed; for which soaking in warm water and afterwards wrapping up the foot, having first dressed it with tar, is sufficient. The feet of sheep are also sometimes injured by long travelling, when the same treatment is proper. The most serious foot rot is that which is, in some instances, simply produced by a long-continued series of humid weather, which predisposes the feet to this injury. In others it appears to be both epidemic and endemial, and has been thought contagious. When the season has been unfavourable, house and soil under cover. The medical treatment consists in removing all diseased portions, and then dressing with the thrush paste, or foot-rot application (*Vet. Pharm.* 655t), and afterwards wrapping up from external exposure. Professor Stonig extols the following application: — Take two parts of tar, and one of oil of turpentine; which having mixed, one part of muriatic acid, known as spirit of salt, is to be added slowly, to which afterwards add four parts of blue vitriol, with which dress the affected feet. (*Journ. de Med. Vet. et Comp.*)

7267. *Staggers, gid, turnsick, goggles, worm under the horn, sturdy, watery head, and pendro*, are all popular terms for hydatids, or an animal now known as the *Tænia globulus*, which, by some unaccountable means, finds its way to the brain, and settles itself there, either in some of its ventricles, or more frequently on its substance. Their size varies from the smallest speck to that of a pigeon's egg, and the sheep it attacks are usually under two years old. These animals are likewise occasionally found in all the natural cavities of the body.

7268. *The appearances of cerebral hydatids* are, stupidity, a disposition to sit on the rump, to turn to one side, and to incline the head to the same while at rest. The eyes glare, and from oval the pupils become round. An accurate examination will now usually discover some softness at a particular part of the skull, generally on the contrary side to that on which the animal hangs the head: when no softness of the skull is discernible, the hydatid usually exists in some of the ventricles, and the destruction of the sheep is certain and quick, from the greater disturbance to the functions of the brain; but when it is situated on the surface, it sometimes requires many months to destroy; an absorption of the bone taking place as the hydatid increases, which produces the thinness in the skull opposite to the affected part.

7269. *This disease is not incurable*, as has been supposed, but it is only relieved by a manual operation. In France it has been successfully treated by the application of the actual cautery: a pointed iron, heated red-hot, is forced through the skin and skull, to the surface of the brain; the principal nicety of which is in penetrating the hydatid with the hot iron without wounding the brain itself. In England, some shepherds are very dexterous in *wiring*, which they do by thrusting a wire up the nostrils till it rests against the skull. In the passage of the wire the hydatid is usually ruptured; others elevate the skull (by means of a trephine, or even a knife) opposite to the softened portion, and extract the hydatid, if possible, whole, which a little care will effect, by drawing it away with a blunt pincer, gently moving it from side to side. Tapping is merely letting out the fluid contents of the hydatid by an awl, which is practised by some shepherds with success; and if the instrument be not thrust to far, the sheep is not injured: to avoid which, it is passed obliquely. A well hardened gimlet is a very proper instrument, with which the skull is easily penetrated, and an opening by the twisting of the instrument is made, sufficiently large in the hydatid itself, to discharge its contents, which is all that is sufficient to ensure its destruction, and which, if no other exists, is followed by immediate recovery. A French author states, that when he fed his sheep on cinquefoil he had less staggers than at any other time.

7270. *Frontal worms*. Sheep are observed to gather together, with their noses thrust inwards to avoid the attack of the *Æstrus ovis*, or fly, that lays its eggs on the inner margin of the nose, which having become hatched, the larva creep up into the frontal and maxillary sinuses, to the torment of the sheep, and sometimes to their speedy destruction. The Continental shepherds trepan an opening into these cavities, and effect their removal; but our shepherds have not succeeded in the operation.

7271. *Fluke worms* are a parasitic animal, found in the biliary sinuses, not only of the sheep, but of the horse, ass, goat, deer, &c., and whose existence is rather a consequence than a cause of morbidity.

7272. *Pining, the Vinguish* in Galloway (languishing), is a disease described by Mr. Hogg, the Ettrick shepherd, in a recent number of the *Quarterly Journal of Agriculture*, xi. p. 697. He says, "It is most fatal in a season of drought; and June and September are the most deadly months. If ever a farmer perceives a flock on such a farm having a flushed appearance of more than ordinarily rapid thriving, he is gone. By that day eight days, when he goes out to look at them again, he will find them lying, hanging their ears, running at the eyes, and looking at him like so many condemned criminals. As the disease proceeds the hair on the animal's face becomes dry, the wool assumes a bluish cast; and if the shepherd have not the means of changing the pasture, all those affected will fall in the course of a month." (*Quar. Jour. Ag. Highl. Soc.* vol. ii. No. XI.)

7273. *The diseases of lambs* are principally indigestion, producing sometimes colic, which is relieved as in sheep, and sometimes diarrhœa, to be likewise cured by the means detailed for them. Sheep are also liable to an eruptive disease which begins on the rump, gradually extending along the chine, and when it becomes more universal, it usually destroys. The cure consists in giving daily drinks of half a drachm of cream of tartar, and one drachm of sulphur, in four ounces of chamomile decoction. Anoint also with mild mercurial ointment and Turner's cerate in equal quantities. Lambs dropped in cold weather, or in wet situations, become paralytic: bathe in warm water, hand-rub and house, giving milk and bean meal.

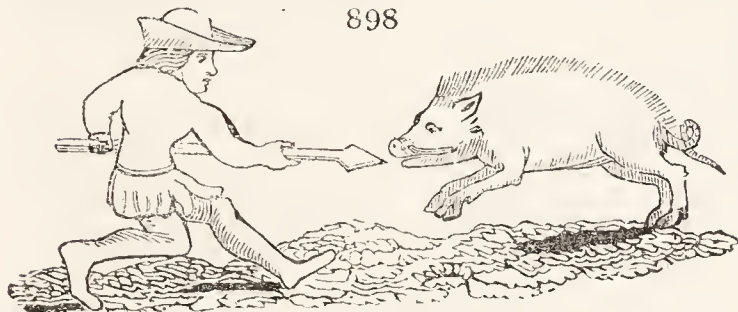
CHAP. VII.

The Swine. — Sús Scrofa L. Cochon, Fr.; Schwein, Ger.; Puerco, Span.; and Porco, Ital.

7274. *Of swine* there are several species, but none in general domestication, or much used as food when taken wild, excepting the common sort, which includes the wild hog or wild boar, the original stock of our domestic breed, the European hog, and the Chinese hog.

7275. *The common hog* is found either in a wild or domestic state, in almost all the temperate parts of Europe and Asia; but it is not met with in the most northern parts of these continents. It is found in many parts of Africa. Mr. Pennant asserts, that the wild boar was formerly a native of this country, and hunted from the middle of November to the beginning of December; and it is asserted by Fitz-Stephens, that the vast forest which in his time grew on the north side of London, was the retreat of stags, wild boars, and bulls.

7276. *The wild boar* is still found in the forests of Germany, and in other parts of the Continent; and although now extinct in Britain, appears from ancient paintings (*fig. 898.*) to have been hunted by our ancestors. It feeds upon roots, acorns, and other vegetables: it is generally as large as the domestic hog, and is either dark grey or blackish, when full grown, and pale red or rusty brown when young. Between the bristles, next the skin, is a finer or softer hair of a woolly or curling nature. The snout is somewhat longer in proportion than that of the domestic animal; but the principal difference is in the superior length and size of the



tusks, which are often several inches long, and capable of inflicting the most severe and fatal wounds. The hunting of the wild boar forms one of the principal amusements of the great in some parts of Germany, Poland, &c. and is a chase of some difficulty and danger, not on account of the swiftness, but the ferocity of the animal. Wild boars, according to Buffon, which have not passed the third year, are called by the hunters beasts of company, because previous to that age they do not separate, but follow their common parent. They never wander alone till they have acquired sufficient strength to resist the attacks of the wolf. These animals, when they have young, form themselves into flocks, and it is upon this alone that their safety depends. When attacked, the largest and strongest front the enemy, and by pressing all round against the weaker, force them into the centre.

7277. *Of the tame hog*, white is the most general colour; but other colours are often intermixed in various proportions. In some respects, the hog seems to form an intermediate link between the whole and the cloven-footed animals: in others he seems to occupy the same rank between the cloven-footed and digitated. Destitute of horns; furnished with teeth in both jaws; with only one stomach; incapable of ruminating; and producing at one birth a numerous progeny: the union of these faculties confers on the hog a remarkable peculiarity of character. He does not, like other animals, shed his fore teeth and put forth a second set, but retains his first set through life.

7278. *Hogs seem to enjoy none of the powers of sensation in eminent perfection.* They are said to hear distant sounds; and the wild boar distinguishes the scent of the hunter and his dogs, long before they can approach him. But so imperfect is their feeling, that they suffer mice to burrow in the fat of their backs without discovering any uneasiness, or appearing even to notice it. In their taste they show a singular degree of caprice. In the choice of herbs they are more delicate than any other herbiferous animal, yet devour the most nauseous and putrid carrion with more voracity than any beast of prey. At times they do not scruple to eat their own young; they will even mangle infants out of desperate voracity.

7279. *Hogs are remarkable for the smallness of their eyes:* hence a person whose eyes are very diminutive, and deep sunk in his head, is said to be pig-eyed. The form of the hog is inelegant, and his carriage is equally mean as his manners. His unwieldy shape renders him no less incapable of swiftness and sprightliness, than he is of gracefulness of motion. His appearance is always drowsy and stupid. He delights to bask in the sun, and to wallow in the mire. An approaching storm seems to affect his feelings in a very singular manner. On such an occasion, he runs about in a frantic state, and utters loud shrieks of horror. Hogs are infested with lice, and are subject to many disorders, such as the scurvy, scab, and scrofula. The sow brings forth in the beginning of the fifth month after conception, and she has often two litters in a year. She generally produces a numerous progeny at a birth; but her first litter is less numerous than those that follow. Hogs, when suffered to see the natural term of life, live from fifteen to thirty years. Their size and strength continue to improve till they are five or six years old.

7280. *Tame hogs are often very troublesome* in cultivated grounds, ploughing them up with their snouts, and thus entirely frustrating the labours of the agriculturist. Worms, the wild carrot, and other roots, are the objects of their search. The wild boar having a longer and stronger snout than the domestic variety, digs deeper, and continues his furrow nearly in a straight line. The inhabitants of America find the hog very beneficial in clearing their lands of rattlesnakes and other serpents, upon which he constantly preys, without apparently suffering any injury.

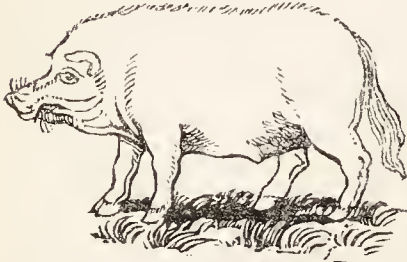
7281. *The hog is, in a very considerable degree, beneficial to mankind.* His flesh is pleasant, substantial, and nutritious. It affords numberless materials for the table of the epicure; among these is brawn, which seems peculiar to England. Pork takes salt better than the flesh of any animal, and is, in consequence, preserved longer, and always makes an important article in naval stores. The lard of the hog is essential to the cook and confectioner; it is used in various medical preparations, and is compounded by the perfumer into pomatums. The bristles are made into brushes, and are, moreover, of great use to the shoemaker. The skin is worked into coverings for pocket-books, and other articles.

7282. *The hog in British farming* is in general viewed as a subordinate species of live stock, and chiefly valuable as consuming what would otherwise be lost. There are, however, swine husbandmen who keep large herds to advantage, especially millers, brewers, distillers, and dairymen, to whom they are an object of importance; and return, for the offal they consume, a greater weight of meat, according to some double the weight, than could be obtained from cattle. In those parts where potatoes are raised as a fallow crop, much beyond the demand for them as human food, — as is the case in particular in Ireland, and the west of Scotland, — the rearing and feeding of swine, the most of them sent to a distance in the state of bacon and pickled pork, is a branch of management on which great dependence is placed for the payment of their rents and other charges. The prolific nature of this animal, however, rendering it so easy to increase the supply beyond the demand, the price of swine flesh varies more than that of any other sort of butcher's

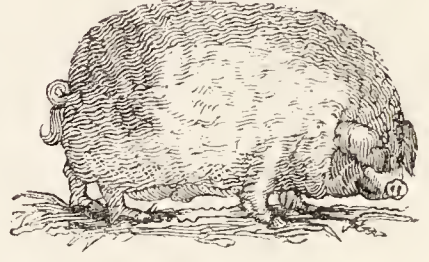
meat, and their culture can never be so much depended on by the general farmer as that of cattle or sheep. A writer in the *Farmer's Magazine* observes, that the swine are the only variety of granivorous animals that can be fed upon the offal of grain, or such articles as would otherwise go to waste about a farmstead. Since the erection of threshing machines, a much greater quantity of light grain is beat from the straw, than was gained when the flail was employed. To use this extra quantity to advantage becomes an important concern to the occupiers of land; and this writer thinks that the using of it in raising and supporting swine is by far the most profitable mode of consuming an article, which, in other respects, is comparatively of little value.

SECT. I. Varieties of the Common Hog.

7283. The domesticated European variety of the common hog (fig. 899.) is too well known to require any description.



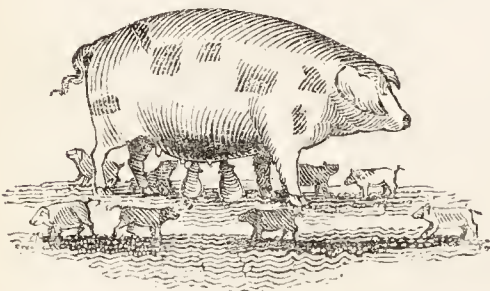
7284. The Chinese hog (fig. 900.) is distinguished from the common, by having the upper part of its body almost bare, its belly hanging nearly to the ground; its legs are very short, and its tail still more disproportionately short. The flesh of this variety is whiter and more delicate. The colour is commonly a dark grey. It



abounds in China, and is diffused through New Guinea, and many islands in the South Sea. The New Hebrides, the Marquesas, the Friendly and the Society Islands, possess this animal, and cultivate it with great care, as it is almost the only domestic animal of which they can boast. The varieties of hog cultivated in Britain, are partly the result of climate and keep in the European variety, and partly the effects of crossing with the Chinese. At the same time, it is only in particular districts that so much attention has been paid to this animal, as to give rise to any accurate distinction of breeds; and nowhere has it received any considerable portion of that care in breeding, which has been so advantageously employed on the other animals of which we have treated. Yet, among none of the varieties of those is there so great a difference as among the breeds of this species, in regard to the meat they return for the consumption of a given quantity of food. Some races can with difficulty be made fat, even at an advanced age, though fed from the trough with abundance of such food as would fatten any other animal; while others contrive to raise a valuable carcass out of materials on which no other creature could subsist.

7285. The Chinese race, according to Culley, has been subdivided into seven varieties or more; and it would be easy to point out twice the number of as prominent distinctions among the sorts in the third class. But such an affectation of accuracy is as useless as it would be tedious. One general form, approaching to that of other animals kept for their carcass, ought certainly to be preferred; and the size, which is the other distinguishing characteristic, must be chosen with a view to the food provided for their maintenance, and not because it is possible to raise the individuals to a great, and probably, unprofitable weight. The fineness of the bone, and the broad, though also deep, form of the chest, denote in this, as in the other species, a disposition to make fat with a moderate consumption of food; and while it may be advisable to prefer the larger breeds in those places where bacon and fitches are in most demand, the smaller breeds are most esteemed for pickling, and are, beyond all doubt, most profitable to those farmers who allow them little else than the range of the farm-yard and the offals of the kitchen.

7286. The Berkshire breed (fig. 901.) is distinguished by being in general of a tawny, white, or reddish colour; spotted with black; large ears hanging over the eyes; thick, close, and well made in the body; legs short; small in the bone; having a disposition to fatten quickly; and when well fed, the flesh is fine. Berkshire has been long famous for its breed of swine, which, as it now stands, is, in the third class, in point of size, excellent in all respects, but particularly as a cross for heavy, slow-feeding sorts. It has extended itself from the district from which it takes its name over most parts of the island; is the sort mostly fattened at the distilleries; feeds to a great weight; is good for either pork or bacon; and is supposed by many as the most hardy, both in respect to their nature and the food on which they are fed.



7287. The Hampshire breed (fig. 902.) are large, longer in the body and neck, but not of so compact a form as the Berkshire; they are mostly of a white colour, or spotted, and are well disposed to fatten, coming up to a great weight when properly managed in respect to food. Lawrence says they are generally dark spotted, some black, of a longer and flatter make than those of Berks, ears more pointed, head long and sharp, resembling the Essex.

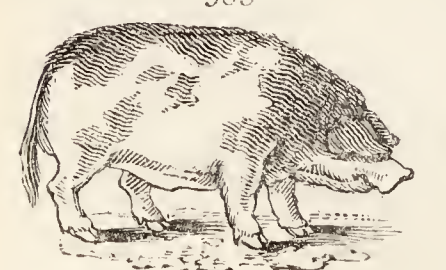
7288. The Shropshire breed is another large breed of hogs, which are found valuable where the keep is in sufficient abundance for their support. They are not so well formed as those of the Berkshire kind, or equal to them in their disposition to fatten, or to be supported on such cheap food. The standard colour of this breed is white, or brindled: Shropshire has long bred stores for the supply of the London feeders, and of the Essex farmers, who thus turn their clovers to the most profitable account.

7289. The Gloucestershire breed is likewise a larger breed, but inferior to either of the above, being tall and long in shape, and by no means so well formed. The colour is in general white. It has two wattles hanging from the throat.

7290. The Herefordshire breed (fig. 903.) is also a large useful breed, but perhaps without possessing any advantage over those that have been described above.

7291. The Rudgwick breed is a large kind of swine, which the author of the *Survey of Middlesex* says is the largest in the island, met with at the village of that name, on the borders of Sussex and Surrey. They feed to an extraordinary size, and weigh, at two years old, nearly double or triple the usual weight of other sorts of hogs of that age. As large breeds pay the farmers best in many cases, such a breed deserves to be attended to in the system of hog management.

7292. The large spotted Woburn breed is a breed introduced by the late Duke of Bedford, being large in size and of various colours. It is a hard, well formed, prolific sort, rising quickly to a large weight.



7293. *The Wiltshire breed* is a long-bodied, low hog, hollow about the shoulder, and high on the rump, middling large pointed ears, round bone, light in colour.

7294. *Yorkshire breed.* This, in the old breed, was probably the worst large variety we had; extremely long-legged and weak-loined, their constitution not of the soundest, and bad sty-pigs in the winter season; they were yet quicker feeders than some of the superior breeds. They have been improving some years from the Berkshire cross, but are still inferior to the north-western stock, rendering a less price at market.

7295. *The Northamptonshire breed* was formerly a handsome, light-eared, white, deep-sided pig, with middling bone, and quick of proof: the breeders have since tried the new Leicester.

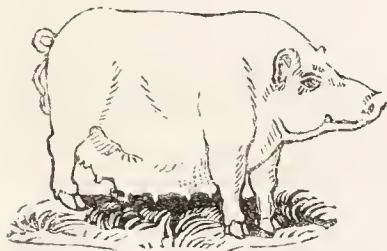
7296. *The Leicestershire breed* is, in the original stock, large, deep, and flat-sided, light-spotted, with rather handsome head and ears. The Bakewell variety has much merit.

7297. *The Lincolnshire breed* was formerly light-coloured and white, like those of Northamptonshire, many of them having curled and wooly coats. They are middle-sized, quick-proving pigs.

7298. *The Norfolk breed* is a small, short, up-eared porking sort, various in colour, white, bluish, striated, generally an inferior kind, which it would be to the interest of that great corn county to improve; they are, however, of a thin-skinned, quick-proving kind. But in the vicinity of Lynn, and generally on the Lincoln side of the county, there is a larger spotted variety of very good form and quality, which should be encouraged.

7299. *Suffolk breed.* (fig. 904.) This is a small, delicate, white pig, which has for many years had great reputation; and at this time there is not only a strong prejudice in their favour in their own county, but they have many advocates out of it. They are shorter and more pug-formed than the Norfolks, and by their dish-face, and pendent belly, it may be supposed that the variety proceeded originally from the white Chinese. Some of the Suffolks are very handsome, and very regularly shaped.

904



7300. *The Essex breed* are up-eared, with long sharp heads, roach-backed, carcasses flat, long, and generally high upon the leg, bone not large, colour white, or black and white, bare of hair, quick feeders, but great consumers, and of an unquiet disposition.

7301. *The small, white, English breed* is met with in many districts; it is of a white colour, thick, compact, and well made in the body; short in the leg; the head and neck well formed, and the ears slouch-

ing a little downwards. It is well disposed to fatten, and perfectly hardy. It prevails much in the northern districts.

7302. *Swing-tailed breed.* This is a useful sort of the smaller kind of hogs, hardy in its nature, and of considerable weight in proportion to its size.

7303. *There are many other varieties and subvarieties in England* which it is unnecessary to notice here. Donaldson remarks, that the Berkshire and Hampshire hogs are the largest; but that it is most probably from the Berkshire stock that the greatest number of the varieties of the country have sprung.

7304. *Of the Highland breeds*, that of the Hebrides, supposed by Dr. Walker to be the original, is of the smallest size, neither white nor yellow, but of a uniform grey colour, and shaggy, with long hair and bristles; they graze on the hills like sheep; their sole food is herbage and roots, and on these they live the whole year round, without shelter, and without receiving any other sustenance. In autumn, when they are in the best order, their meat is excellent, and without any artificial feeding; but when driven to the low country, they fatten readily, and rise to a considerable bulk. (*Walker's Hebrides*, vol. ii. p. 17.) In the Orkney islands they are commonly of a dark red or nearly black colour, and have long bristles, with a sort of coarse wool beneath them.

7305. *The old Irish breed* are a long-legged, thin-sided, lank, haggard, unprofitable sort of swine; but where they have been crossed with the Berkshire, they are considerably improved.

SECT. II. *Breeding and Rearing of Swine.*

7306. *In the breeding of swine*, whatever be the variety, the most perfect and best formed boar and sow should be chosen, and a due regard paid to their age, time of copulation, period of gestation, farrowing, castrating or spaying, and weaning.

7307. *In choosing the boar and sow*, regard must be had to their size, as well as perfection of form. Where food is abundant, or the object of the progeny is the production of bacon and flitches, the larger breeds, as already observed, are to be preferred: but where food is scarce or uncertain, as in the case of the cottager's stock, or rearing for suckled pork, fresh pork, or pickled pork, the smaller breeds, as the Berkshire, are to be preferred. A breeding sow ought to have a large capacious belly, and not to be too much inclined to obesity. To check this tendency, some allow them to breed five times in two years.

7308. *The age of the boar* should not be less than a year, as he will then be at his full growth; nor that of the female less than ten months. They may be used in breeding for three or five years, and then fed off for the shambles.

7309. *The period of gestation* in swine is about four months, so that two litters may be easily produced in a year, five in two years, or ten in four years.

7310. *The best times for copulation* are November and May; because then the progeny are brought forth in mild weather, and when green food is to be had. They should not be allowed to farrow in winter, as young pigs are exceedingly tender, and can with difficulty be preserved in very cold weather; nor at a time when food is scarce, as is generally the case upon corn farms in summer, if the stock of them is large. When the object is suckled pigs for the shambles, copulation should be so contrived as to produce parturition at all seasons.

7311. *The usual produce* is from about eight to ten or twelve pigs in the large but more in the smaller breeds, which in general bring the greatest number, and the most early. Twenty swine are estimated to bring at an average seven pigs and a half each for their first litter; but the number varies much, and many young pigs are lost soon after their birth by the unkindness of their dam, and by casualties, to which they are more exposed than most other young animals.

7312. *The pregnant swine* should be separated from the herd some time before she is expected to farrow, carefully watched, and littered with a small quantity of dry short straw. Too much straw is improper, both at the time of farrowing, and for a week or two afterwards, as the pigs are apt to nestle beneath it unperceived by the sow, and are thus in danger of being smothered when she lies down. A breeding sow should be well fed, particularly when nursing; and it is advantageous early to accustom the pigs to feed from a low trough on milk or other liquid food, mixed with meal or bran. Such of the pigs of both sexes as are not to be kept for breeding are usually castrated or spayed when about a month old, and the whole may be weaned at the end of six or seven weeks.

7313. *The food allowed to growing swine* depends in almost every case upon the circumstances of their owners; for, as already observed, it is a doubtful point whether swine will pay when all their food both in rearing and fattening is to be purchased. The cottager's pig must be contented with the scanty offals of his kitchen and of his dairy, the produce generally of a single cow; towards the end of autumn a few potatoes are added for the purpose of preparing it for the slaughter, and perhaps a little meal is mixed with boiled potatoes for a week or two before. Such pigs, however, often thrive amazingly, make themselves moderately fat, and form a most valuable addition to the winter stores of their owners. In the south-eastern

counties of Scotland, the hinds or married ploughmen are commonly allowed to keep a pig each, which they feed in this manner, and from which their families derive much benefit at very little expense. Near woods, acorns, mast, and other seeds, as well as some roots and vermin, afford excellent nourishment. On many corn farms, the chief, and not unfrequently the only, dependence of swine is on the straw-yards. The sweepings of the barn floor, corn left upon the straw, and oats found among the dung of horses, with a share of the turnips given to the cattle in winter, and of the clover in summer, afford ample subsistence to swine, in the proportion, perhaps, of one to every five or six acres under corn, clover, and turnips. The kitchen and dairy give some assistance to pigs newly weaned, and also to such as are soon to be slaughtered. A great many are killed when about a year old, that have never been fed at any expense that can be estimated. A few pigs, if of a good breed, will always be moderately fat at that age with the run of the straw-yard, and their flesh is of an excellent quality.

7314. *To prevent swine from digging* in the soil, the best method is to cut the two strong tendons of their snouts with a sharp knife, about an inch and a half from the nose. This may be done with little pain, and no prejudice, to the animal when about two or three months old. The common practice of restraining them by rings fixed in the snout is painful and troublesome; they must be replaced as often as they give way, and that happens so frequently that rings afford but little security against this nuisance.

SECT. III. *Fattening of Swine.*

7315. *The following system of rearing and fattening swine on an arable farm* is recommended by a writer in the *Farmer's Magazine*.

7316. *Upon a tillage farm* consisting of three hundred acres, whereof two hundred are kept under the plough, he is of opinion that a considerable sum may be annually gained from keeping swine, were the management arranged in a systematic manner. One main advantage of such a branch of rural economy arises from little or no capital being required to carry it on, while the trouble and outlay attending it scarcely deserve notice. With the addition of one acre of broad clover, and one acre of tares, for the summer and autumn months, and the like extent of ground for turnips and yams during the winter and spring months, this stock of swine may be amply supported.

7317. *Were two breeding sows* kept on a farm of the size mentioned, and their produce reared by the farmer, it may be calculated that forty swine, weighing seven or eight stone each, would be annually fed off, in the month of January and February each year, the time when pork is most in demand. That such a number of swine can be supported and fed upon the offals of a three-hundred-acre farm, and the other auxiliary articles specified, may be pronounced a certain fact.

7318. *The breeds* he recommends are the hardy smaller sized varieties; because he has found that such breeds will thrive and grow fat where larger and finer breeds would starve.

7319. *The mode of management* is, that a boar and two good sows of a proper age should constantly be kept, and that one young sow shall annually be reared, in order to supply the others when they pass maturity. He would cast off the oldest sows, *i. e.* feed them when they arrive at three years of age, which, of course, would cause four sows to be in hand at one time. These annually would produce more than the forty pigs which are to be held on; but the remainder might be sold as they are weaned, there being a regular and steady demand in most parts of the country for young pigs. He has for a number of years kept a stock of swine in the way recommended. They go at large in the court or yard belonging to the farm, and receive a feeding of offal grain in the morning, and of yams or turnips in the evening; and the meat fed in this way has constantly drawn the highest price. They get also the dish-washings of the house, any milk or whey that remains unconsumed, and have the dunghill to roam upon, where perhaps more food is to be gathered, especially if the horses are fed upon unbroken grain, than is commonly imagined. It will readily be concluded that, under this mode of management, the latter end of summer and the harvest months is the critical period for carrying on a stock of swine. During these months little threshing goes forward, and horses seldom receive any corn for aliment; hence all that can be consistently attempted is to keep the animals in a growing state, and prepare them for fattening cleverly, when food of a more nutritious quality can be procured. Clover and tares will do this effectually, the last particularly so when in a podded state. Turnips can also be got by the end of September; and it must be recollected, that through the summer months a considerable quantity of milk and whey can be given, upon which swine will be found to thrive heartily. He does not know a more beneficial stock upon a farm than swine, so long as the quantity kept is in proportion to the extent of offals about the premises. The other articles recommended are merely meant to render the consumption of offals more beneficial, to carry on the stock at periods when such offals are scarce. The charge of attendance is very small; indeed, the benefit gained by the dunghill will more than compensate the expenses incurred. To make as much profit from cattle or sheep requires a great advance of money; but in the article of swine hardly any is necessary, while the most part of the articles consumed cannot, in any other way, be converted to such beneficial purposes.

7320. *In fattening for bacon and stiches*, the larger breeds are chosen; and in breweries, distilleries, oileries, and dairies, fed on grains, oil-cake, and milk; but where arable farmers keep swine of this description, as is the practice in some of the western counties, the method is to rear chiefly on raw potatoes and Swedish turnips, and to fatten on these roots, boiled or prepared by steam, with a mixture of oat, barley, or bean and pea meal. Their troughs should be often replenished with a small quantity of food at a time, and kept always clean; and their food changed occasionally, and seasoned with salt. If proper care be taken, says a late writer, a feeding pig should not consume more than six Winchester bushels of oats made into meal. It ought to be shelled before it is ground, the same as for family use, but need not be sifted. (*Henderson's Treatise on Swine*, p. 26.)

7321. *In fattening sucking pigs*, all that is requisite is to keep the mother well lodged and nourished. Weaned pigs when to be fattened are kept constantly on whey, or skim-milk or buttermilk, with frequently an addition of peas or beans, or barley-meal. Such good keeping not only makes them increase rapidly in size, but renders them fit for the butcher at an early age. Swine are sold to the butcher at different ages, and under different names; as pigs when a few weeks old; as porkers at the age of five or six months; and as full grown hogs at from eighteen months to two years old. The young pigs are commonly roasted whole; the porkers are used as fresh or pickled pork; and the full grown hogs are for the most part converted into ham and bacon. The demand for porkers, which for London in particular is very great, and which continues almost throughout the year, is chiefly supplied from the dairies within reach of that metropolis.

SECT. IV. *Curing of Pork and Bacon.*

7322. *The curing or pickling of pork* is carried on to a considerable extent at many of our sea-ports.

7323. *The carcass is cut in pieces*, and packed in cases or kits made for the purpose, containing from one to two hundred weight. Salt is dissolved in water till the mixture be strong enough to swim an egg; it is then boiled, and, when cold, poured upon the pork; when the end of the cask is fixed in, the article is ready for being sent to market. Henderson, a late writer, has given particular directions for the curing of bacon, founded upon a long course of experience, which, therefore, deserves to be more generally known.

7324. *The curing of bacon* is thus described by Henderson, after much experience : —

7325. *After the carcass* has hung all night, lay it upon a strong table, or bench, upon its back ; cut off the head close by the ears, and cut the hinder feet so far below the hough as will not disfigure the hams, and leave plenty of room to hang them by ; then take a cleaving knife, and if necessary, a hand mallet, and divide the carcass up the middle of the back-bone, laying it in two equal halves : then cut the ham from the side by the second joint of the back-bone, which will appear on dividing the carcass ; then dress the ham, by paring a little off the flank or skinny part, so as to shape it with a half round point, clearing off any top fat that may appear ; the curer will next take off the sharp edge along the back-bone with his knife and mallet, and slice off the first rib next the shoulder, where he will perceive a bloody vein, which he must take out ; for if it is left in, that part is apt to spoil. The corners must be squared off where the ham was cut out.

7326. *In killing a number of swine*, what sides you may have dressed the first day lay upon some flags or boards, piling them up across each other, and giving each pitch a powdering of saltpetre, and then covering it with salt : proceed in the same manner with the hams, by themselves, and do not omit giving them a little saltpetre, as it opens the pores of the flesh to receive the salt, and besides, gives the ham a pleasant flavour, and makes it more juicy. Let them lie in this state about a week, then turn those on the top undermost, giving them a fresh salting : after lying two or three weeks longer, they may be hung up to dry in some chimney, or smoke-house ; or, if the curer chooses, he may turn them over again without giving them any more salt, in which state they may lie for a month or two without catching any harm, until he has convenience for drying them. Henderson practised for many years the custom of carting his fitches and hams through the country to farm-houses, and used to hang them in their chimneys and other parts of the house to dry, some seasons, to the amount of five hundred carcasses : this plan he soon found was attended with a number of inconveniences, and therefore he invented a smoking-house.

7327. *Henderson's smoking-house* is about twelve feet square, and the walls about seven feet high : one of these huts requires six joists across, one close to each wall, the other four laid asunder, at proper distances. To receive five rows of fitches, they must be laid in the top of the wall ; a piece of wood strong enough to bear the weight of one fitch of bacon must be fixed across the belly end of the fitch, by two strings, as the neck end must hang downwards : the piece of wood must be longer than the fitch is wide, so that each end may rest upon a beam ; they may be put so near to each other as not to touch ; the width of it will hold twenty-four fitches in a row, and there will be five rows, which will contain one hundred and twenty fitches ; as many hams may be hung at the same time above the fitches contrived in the best manner we can. The lower end of the fitches will be within two and a half or three feet of the floor, which must be covered five or six inches thick with sawdust, and must be kindled at two different sides ; it will burn, but not cause any flame to injure the bacon. The door must be kept close, and the hut must have a small hole in the roof, so that part of the smoke may ascend. That lot of bacon and hams will be ready to pack up in a hogshead, to send off in eight or ten days, or a little longer, if required, with very little loss of weight. After the bacon is salted, it may lie in the salt-house as described, until an order is received, then immediately hang it up to dry. Henderson found this smoke-house to be a great saving, not only in the expense and trouble of employing men to cart and hang it through the country, but it did not lose nearly so much weight by this process.

7328. *In the disposal of bacon*, whatever is shipped for the London market, or any other, both bacon and hams, must be packed into a sugar hogshead, or something similar, to hold about ten hundred weight. Bacon can only be cured from the middle of September until the middle of April. (*Henderson's Treatise on Swine*, p. 39.)

SECT. V. *Diseases of Swine.*

7329. *Swine are subject to various diseases*, but according to Lawrence they are not easily doctored.

7330. *They are subject*, he says, to pox or measles, blood striking, staggers, quincy, indigestion, catarrh, peripneumonia, and inflammation of the lungs called heavings. When sick, pigs will eat, and they will take medicine in their wash ; when they will not eat, there is no help for them. As aperients, cleansers, and alteratives, sulphur, antimony, and madder are our grand specifics, and they are truly useful. As cordials and tonics, treacle and strong beer, in warm wash, and good peas and pollard. In the measles, sulphur, &c. and, if the patient require it, give cordials now and then ; in staggers, bleeding, fresh air, and perhaps nitre ; in catarrh, a warm bed, and warm cordial wash ; and the same in quincy, or inflammation of the glands in the throat. If external suppuration appear likely, discharge the matter when ripe, and dress with tar and brandy, or balsam. The heavings or unsoundness of the lungs in pigs, like the unsoundness of the liver in lambs, is sometimes found to be hereditary ; there is no remedy. This disease in pigs is often the consequence of colds from wet lodging, or of hasty feeding in a poor state ; in a certain stage it is highly inflammatory, and without remedy. Uction with train oil, and the internal use of it, have been sometimes thought beneficial.

CHAP. VIII.

Of the Goat, Rabbit, Hare, Dormouse, Deer, and various other Animals, that are or may be subjected to British Agriculture.

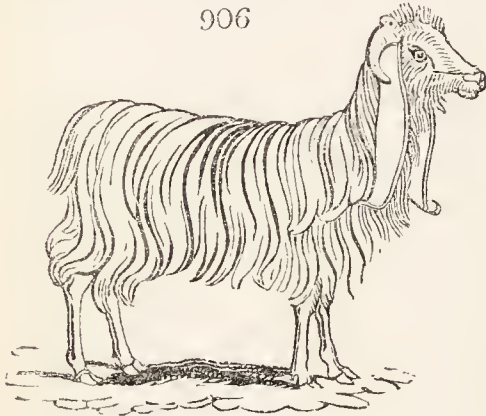
7331. *The goat* (*Capra Aegagrus L.*, fig. 905.) is a native of many mountainous parts of Europe, Africa, Persia, and India : he is domesticated throughout Europe, feeds on branches of shrubs, on lichens, hemlock, &c. ; is seldom destitute of horns, of active habits like the deer, treacherous, petulant, roaming, and lascivious ; gravid four months and a half, brings from one to two at a birth, and lives ten or twelve years. The female will allow herself to be sucked by the young of various other animals ; and a foal which has lost its mother has been seen thus nourished by a goat, which, in order to facilitate the process, was placed on a barrel. The attachment between the nurse and foal appeared strong and natural : in its internal structure, it ex-



tremely resembles sheep, but is far superior to them in alertness, sentiment, and intelligence. The goat approaches man without difficulty, is won by kindness, and capable of attachment. The extremely unpleasant odour attending these animals is supposed to be beneficial, and horses appear so much refreshed by it, that a goat is, on this account, often kept in the stables of the great. It is a singular local peculiarity, that in Angora only, the animals of the *Càpra*, *O'vis*, and *Lèpus* tribe, have long soft silky hair.

7332. *The Angora goat*, a native of Turkey, is chiefly valued for its exquisitely fine hair down, which grows under its coarse hair, and of which the Cashmere shawls are manufactured. The down is obtained by gently combing them. A considerable number of this breed were imported into France from Persia, in 1819, and stationed at St. Omers, with a view to their increase, and the establishment of the shawl manufacture. The kids of this flock are said to be abundantly covered with down and hair, and superior in strength and appearance to indigenous French kids of the same age. It is a common opinion, that the down of this goat degenerates when the animals are removed from the pasturage of Angora; but this is likely in part to arise from the neglect of cleaning and washing them, which at Angora is so assiduously attended to. By a late Report of M. Terneaux to the Paris Agricultural Society, the French Angoras have increased in number, and prosper equally with the native variety.

906



7333. *The Syrian goat* (fig. 906.) is remarkable for its pendulous ears, and is common throughout the East, in Egypt, and on the coast of Africa. It has likewise been introduced into Sicily, but can only be kept in health in very warm situations.

7334. *The Chamois goat*, a native of Switzerland, is a species of antelope, and will be afterwards noticed.

7335. *The goats of Wales* are generally white, and are both stronger and larger than those of other hilly countries. Their flesh is much used by the inhabitants, and often dried and salted, and substituted for bacon. The skins of the kids are much valued for gloves, and were formerly employed in furniture, when painted with rich colours, of which they are particularly capable, and embellished with ornamental flowers, and works of silver and gold. The goat may be of some advantage in rocky barren countries, where nothing else can get a support for life. They will climb the steepest rocks, and there browse upon briars, heath, and shrubs of various kinds, which other creatures will not taste of. They will feed on grass in pastures; but, as they love browsing on trees much better, great care should be taken to keep them from valuable plantations.

7336. *The produce of the goat*, from which advantage is chiefly obtained, is the milk, which it yields in large quantities, and which is accounted the best milk of all animals. They mix this and cows' milk together in some parts of the kingdom, and a very valuable cheese is made from it. Besides this, the kids or young goats are very fine food, and the best kinds bring forth two or three at a time, and that twice a year.

7337. *Goat's hair* is also valuable; it may be sheared as the wool from sheep, and is excellent for making ropes that are to be used in the water, as they will last a great while longer than those made in the common way. A sort of stuff is also made of it in some places.

7338. *The suet of the goat* is also in great esteem, and many of the inhabitants of Caernarvonshire kill them merely for the sake of their fat, which makes candles of a superior quality to the common. Of their horns excellent handles are made for tucks and penknives. The skin is peculiarly well adapted for the glove manufactory, especially that of the kid, as it takes a dye better than any other skin. The old skin is also of great use, being preferred to that of the sheep, and the flesh affords a cheap and plentiful provision in the winter months, particularly when the kids are brought to market. The haunches of the goat are frequently salted and dried, and supply all the uses of bacon: this by the Welsh is called *coch yr wden*, or hung venison.

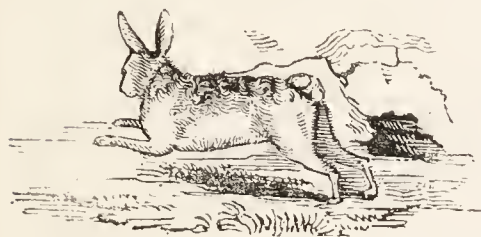
7339. *The kind of goats for keeping to advantage* should be chosen in this manner:—The male should have a large body, his hair should be long, and his legs straight and stiff; the neck should be plain and short, the head small and slender, the horns large, the eyes prominent, and the beard long. The female should have a large udder, with large teats, and no horns, or very small ones. Goats should be kept in flocks, that they may not straggle; and they should have good shelter both in summer and in winter, the heat and cold being both prejudicial to them, and coupled in December. They should have no litter in winter, but only a paved floor kept clean. The kids are to be brought up for the table in the same manner as our lambs are.

7340. *The Cashmere shawl goat* has been successfully introduced into England, by C. T. Tower, Esq. of Weald Hall, Essex; and as that gentleman by this time must have some of his flock to dispose of, we think their introduction among cottagers for their wool, and also, as suggested (*Gard. Mag.* vol. v. p. 532.), for their milk, a fair subject for some of our female readers to speculate on. This variety of the common goat, or probably it may be a distinct species, is a fine-looking animal, and would be very ornamental in a park, on a ruin, on the roof of a cottage, or in a churchyard. It would also be very pleasant to have a home-made Cashmere shawl. We shall therefore give all the information we can on the subject from Mr. Tower's account, as published in the last volume (xlvi.) of the Transactions of the Society of Arts. The Cashmere goat was brought from Persia to France during the time of Napoleon, and under his patronage, by the celebrated M. Terneaux, in 1823. Mr. Tower, happening at that time to be in Paris, purchased four of them, two males and two females, and succeeded in conveying them safely to his residence in Essex. The soil of the park at Weald Hall, where they have been kept ever since, is moist, and the situation is much exposed. The animals have, nevertheless, continued in health and multiplied rapidly; so that his present flock consists of twenty-seven, including the four original ones. Of these latter a polled female, which was old when purchased by him, has every year produced at least one kid, and has twice had twins. Those individuals of which the horns cross are in Persia esteemed the best; and one of Mr. Tower's last year's kids has this peculiarity. They show no impatience of cold, and are very healthy, requiring only the occasional shelter of a shed, in very rough weather. In spring, summer, and autumn, they graze like sheep; and during winter have been fed with hay, and refuse vegetables from the garden; but their favourite food is gorse (*Ulex europæa*), which they devour eagerly, without being annoyed by its prickles. They damage young plantations, but not more than other goats or deer will do. They breed very early; three of Mr. Tower's goats this year produced kids before they were themselves a twelvemonth old. A few produce brown wool; but that of far the greater proportion of the goats is white, and this latter is more valuable than the other. The coat is a mixture of long coarse hair, and of short fine wool: this latter begins to be loose early in April; and is collected easily and expeditiously by combing the animals two or three times, with such a comb as is used for horses' manes. A good deal of the long hair comes off at the same time, but the manufacturer has found no difficulty in separating it. The produce of a male is about four ounces, and of a female about two ounces. Two pounds of wool as it comes off the goat's back may be estimated to make one shawl, fifty four inches square. It will therefore require ten goats, male and female, to furnish materials for one shawl. Mr. Tower has this year had three shawls made of his wool,

one of which was examined by the committee of manufacturers. The yarn was spun by Messrs. Pease, of Darlington, and was woven by Messrs. Miller and Sons, of Paisley. Mr. Tower's shawl was compared with one made in Scotland, of French shawl-goat wool, to which it was evidently far superior. It was also compared with a shawl of M. Terneau's own make; and was considered by very competent judges to be superior to this also. (*Trans. Soc. Arts*, vol. xlv. as quoted in *Gard. Mag.* vol. vii.)

7341. *The rabbit* (*Lepus Cuniculus L.*, fig. 907.) is indigenous in most temperate climates, but not so far to the north as the hare.

907



7342. *In a wild state* it forms long winding burrows; keeps its hole by day; feeds morning, evening, and night on vegetables and grain; is the prey of hawks, badgers, polecats, and caught by ferrets; gravid thirty days, brings from four to eight young, five, and sometimes as many as seven times a year. The varieties common in Britain are the white, black, variegated, and silvery grey. The hare and rabbit are distinguished from each other externally, chiefly by the proportional length of the hind legs to that of the back, and in the ears of the hare being longer, and those of the rabbit shorter than the head. The haunts of rabbits are called warrens; which are most numerous in the sandy soils

of Norfolk and Cambridgeshire. They sometimes extend to 2000 or 3000 acres, and many have been hitherto considered to pay better in that state than in any other. Arthur Young, however, has shown in his *Survey of Lincolnshire*, that though a rabbit warren may afford a high interest on the capital of the occupier, yet the rent it affords to the owner of the soil is less than would ultimately be obtained by planting or breaking up, and laying down with chicory or some other suitable herbage plant. In the mean time, as they continue to exist, and are subjected to a kind of management, we shall submit a short outline of it under the heads of extent, soil and situation, fencing, stocking, breeding, rearing, and produce. Afterwards we shall take a view of the mode of managing rabbits in hutches.

7343. *The extent of warrens* varies from 100 to 3000 acres, but a convenient size is considered to be 1500 or 2000 acres. The soil and situation should be dry, sandy, warm, and poor; rich grass or herbage being found to produce a scouring, which sometimes carries off the greater part of the stock. Warrens are generally enclosed with walls either of stone or turf, an essential addition to the latter being a coping of furze, reeds, or stiff straw. Paling is used in some places, but a brook is found insufficient, as the rabbits have been found to swim across.

7344. *Warrens are often stocked* by nature, and all that art has to do in that case is to protect the produce; but in some cases they are formed on ground where rabbits do not exist naturally, or where they exist it is considered desirable to change the breed.

7345. *In stocking a warren*, whether the surface be flat or hilly, artificial burrows are sometimes made, to reconcile the rabbits to the ground, and to preserve them from vermin, until they have time to make their own burrows. These are bored with an auger of a diameter large enough to make a burrow of a sufficient width. In a level warren, these augers may, from time to time, be found useful in forming such holes. They, however, in most cases, are capable of making burrows for themselves. Some warren lands are stocked in the proportion of three couple to an acre; while in others it is in a considerably larger proportion. In Lincolnshire, one buck or male rabbit is said to be sufficient for one hundred does, or females; but this is certainly a much larger proportion than in most other districts. On the wold warrens of Yorkshire, according to Marshal, one male is considered sufficient for only six or seven females, and the nearer they can be brought to that proportion the greater the stock of young ones that may be expected, it being the nature or economy of the males to destroy their young, especially when the proportional number is too great.

7346. *The varieties employed as stock for warrens* are the common grey and silver grey breeds: the former of which is found to be considerably more hardy and much better for the purposes of food; but the latter has greatly the advantage in the value of the skin. Till lately, the common grey rabbit, probably the native wild rabbit of the island, was the only species. At present, the silver-haired rabbit is sought after, and has, within the last few years, been introduced into most warrens. The skin of the grey rabbit is cut; that is, the wool is pared off the pelt, as a material for hats: whereas, that of the silver-haired rabbit is dressed as fur; which, it is said, goes principally to the East Indies. The colour is a black ground, thickly interspersed with single white hairs. The skins of this variety sell for about four shillings a dozen more than those of the common sort; a sufficient inducement for propagating it in preference to the grey breed.

7347. *The rabbit begins to breed at an early age*, as at eight, ten, or twelve months, going only about thirty days with young, the young being little more than three weeks old before they appear from the burrows, during which time they are suckled twice in the day by the mother. It is, therefore, evident that they may breed seven times in the course of the year under good keep, as the does take the buck almost immediately after producing their young. In warrens that are enclosed it is, however, said that they seldom breed more than two or three times in the year.

7348. *The management of a rabbit warren* is a very simple business. Birds and beasts of prey are to be kept off by taking them in traps; dogs and cats kept off, and rats, moles, mice, and other vermin destroyed if abundant or troublesome. Man himself is to be guarded against in some situations. Additional food is to be supplied in the winter season, when the weather is severe, such as fine green hay, saintfoin, clover, turnips, and others of the same sort, which must be distributed over the warrens. It is supposed that turnips answer the best in deep snows, as the rabbits can discover them by the scent. This sort of food is given in the quantity of two or three large cartfuls to a thousand couple per day, and one load of hay in the same time during a storm. It is likewise sometimes the practice to distribute billets of new cut ash boughs, gorse or whins, and other similar woods in the warrens, the bark and other parts of which is eaten, by which the proportion of hay is lessened in a considerable degree. In great snows it is necessary to clear it away from the ditches or fences to prevent the rabbits from getting over them.

7349. *This sort of stock is mostly taken by nets or traps*, set in the form of a fold between the places where they run and those where they feed, the rabbits being hunted into them as they return from feeding. Sometimes they are taken by ferrets and terriers. The wold warreners, Marshal says, have three ways of catching their rabbits; with fold nets, with spring nets, and with types, a species of trap. The fold nets are set about midnight, between the burrows and the feeding grounds, the rabbits being driven in with dogs, and kept enclosed in the fold until morning. But the spring net when used is, he believes, generally laid round a haystack or other place where rabbits collect in numbers. It is added, that the trap is a more modern invention. It consists of a large pit or cistern, formed within the ground and covered with a floor, or with one large falling door, having a small trap-door towards its centre, into which the rabbits are led by a narrow mouth. This trap, on its first introduction, was set mostly by a haystack, hay being at that time the chief winter food of rabbits, or on the outside of the warren wall, where rabbits were observed to scratch much, in order to make their escape. Since the cultivation of turnips as a winter food for this species of stock has become a practice, the situation of the trap has, he says, been changed. Turnips being cultivated in an enclosure within the warren, a trap is placed within the wall of this enclosure. For a night or two the mouth is left open and the trap kept covered (with a board or triangular rail), in order to give the rabbits leave to retreat.

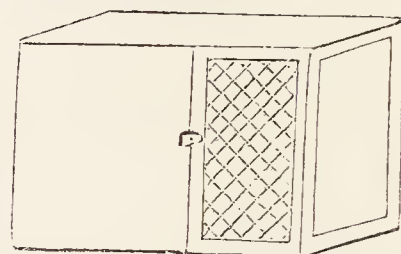
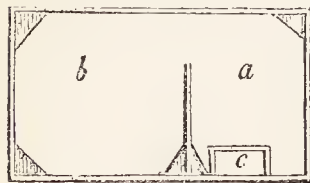
7350. *The annual produce* per acre is mostly estimated at from three or four to eight or ten couple, yielding a profit of from eight to ten, or even fifteen shillings, where they are conducted under a good

system of management. The produce is the largest on new lands; however, much of the profit must always depend on situation, so as to be near good markets. These animals are in what is termed season from the end of October to the beginning of January, in which period the best skins are produced: of course a large proportion of them is killed in this short time. The farmer often sustains great loss in what by the purchasers are called half skins, quarter skins, and racks, sixteen of which are only considered as a whole skin. The rabbits are disposed of by the hundred, six score couple being considered as an hundred.

7351. *The breeding and rearing of tame rabbits* is carried on in hutches or stores of boxes placed in sheds or apartments of any kind secure from vermin. We shall give a view of the practice as to rabbitry and furniture, varieties, breeding, feeding, and produce.

7352. *The rabbit-house* should be particularly dry and well ventilated, as these quadrupeds are very subject to the rot and to liver complaints like sheep.

7353. *The huts or hutches* (fig. 908.) are boxes or chests, eighteen inches or more high, and from two and a half to three feet wide, generally divided in two (*a* and *b*), and the rooms thus formed communicating by a sliding door, the use of which is to confine the rabbits in the inner division (*a*), whilst the outer, which has a wire door (fig. 909.), is cleaning. Generally these hutches are placed in rows above each other against one side of the rabbit-house, and sometimes they are placed in the open air against a wall, within a wired or netted enclosure. Sometimes they are ranged



along the floor; but the neatest mode is to place them on brackets round the room, or on stands about three feet high on the floor. In both these cases it is to be understood that they are not allowed to run about the rabbit-room, the use of which is solely to enclose and protect them in an atmosphere of moderate temperature, and to contain a bin with corn, a truss of clover hay, and any such food as sheep will live and thrive upon. The utensil for feeding rabbits so hutched is simply a trough (*c*), which may be formed of pewter, very hard wood, earthenware; or cast iron, as rabbits are very apt to gnaw them; and it should be divided on the surface crossways every four or six inches, to prevent them from scratching and throwing out their corn. Some add a small rack for their clover, but that will not be lost if given on the floor in small quantities.

7354. *The rabbits of the Angora breed* yield in Normandy a wool which serves as a primary material in several considerable manufactures. It is used alone, and also mixed up with sheep's wool and cotton. The rabbits are found to delight more than any thing in the leaves of the *Robinia pseud-Acacia*; and as this plant grows on common sandy soils, it has been proposed to cultivate it for the sake of these rabbits. (*Com. to Board of Ag.* vol. i. p. 259.)

7355. *There are numerous varieties of tame rabbits*; but the broad-chested and short-legged are the most hardy, and fatten most expeditiously. There is a large variety of the hare colour, which has high-coloured and high-flavoured flesh, more savoury than that of the common rabbit; they make a good dish cooked like the hare, which at six or eight months old they nearly equal in size. The large white and yellow and white species have whiter and more delicate flesh, and cooked in the same way will rival the turkey. The Turkish or French rabbit is esteemed by some, but differs little from the common variety. All these and other varieties are to be had from the London dealers and poultrymen.

7356. *Breeding.* The doe will breed at the age of six months; and her period of gestation is thirty or thirty-one days. It should be premised, that the buck and doe are by no means to be left together; but their union having been successful, the buck must be immediately withdrawn, and the doe tried again in three days: in fact, with rabbits this business is conducted on the same principle as in the stud. Like chickens, the best breeding rabbits are those kindled in March. Some days before parturition or kindling, hay is to be given to the doe, to assist in making her bed with the flue which nature has instructed her to tear from her body for that purpose. She will be at this period seen sitting upon her haunches and tearing off the flue, and the hay being presented to her, she will with her teeth reduce and shatter it to her purpose. Biting down of the litter or bed is the first sign of pregnancy. The number produced, generally between five and ten; and it is most advantageous always to destroy the weak or sickly ones as soon as their defects can be perceived; because five healthy and well grown rabbits are worth more than double the number of an opposite description, and the doe will be far less exhausted. She will admit the buck again with profit at the end of six weeks, when the young may be separated from her and weaned: or the young may be suckled two months, the doe taken back at the end of five weeks, so that the former litter will leave her about a week before her next parturition. A notion was formerly prevalent of the necessity for giving the buck immediately after the doe had brought forth, lest she should pine, and that no time should be lost; and if it were intended that no time might be lost in destroying the doe, such indeed would be the most successful method. Great care should be taken that the doe, during her gestation, be not approached by the buck, or indeed by any other rabbit; as, from being harassed about, she will almost certainly cast her young. One doe in a thousand may devour her young; the sign that she ought to be otherwise disposed of. Some does admit the buck with difficulty, although often apparently in season: such should be immediately fattened off; since it can never be worth while to keep any individual for breeding of a stock to be produced in such multitudes against which there lies an objection. Should the doe be weak on her bringing forth, from cold, cough, or other causes, she will drink beer-caudle as well as any other lady; or warm fresh grains will comfort her, a salt mash, scalded fine pollard, or barley-meal, in which may be mixed a small quantity of cordial horse-ball. With due attention to keeping them warm and comfortable, and guarding against every sudden impression from cold, and more particularly moist air, and with the aid of the best and most nourishing food, rabbits may be bred throughout the winter, with nearly equal success as in the summer season; but in truth their produce is so multitudinous, that one might well be satisfied with four or five litters during the best part of the year, giving the doe a winter fallow.

7357. *Feeding.* According to Mowbray, it is better to feed three times than twice a day. The art of feeding rabbits with safety and advantage is, always to give the upper hand to dry and substantial food. Their nature is congenial with that of sheep, and the same kind of food, with little variation, agrees with both. All weeds and the refuse of vegetation should be banished from rabbit feeding. Such articles are too watery and diuretic, and can never be worth attention whilst the more solid and nutritious productions of the field may be obtained in such plenty, and will return so much greater profit. Rabbits may indeed be kept, and even fattened, upon roots, good green meat, and hay; but they will pay for corn, and this may be taken as a general rule:—Rabbits which have as much corn as they will eat can never take any harm from being indulged with almost an equal portion of good substantial vegetables. However, the test of health is that their dung be not too moist. Many or most of the town feeders never allow any greens at all; the reason, I suppose, because they feed almost entirely on grains. The corn proper for rabbits is oats, peas, wheat, pollard, and some give buck-wheat: the greens and roots the same as our cattle crops; namely, carrots, Jerusalem artichokes, and if potatoes, baked or steamed; lucerne, cabbage leaves, clover, færs, furze. Mowbray has had them hoven from eating rape; and not improbably field-beet might have a similar effect. The best dried herbage is clover and meadow hay, and pea and bean straw.

7358. *Rabbits are generally sold from the teat*, but there is also a demand for those of larger size, which may be fattened upon corn and hay, with an allowance of the best vegetables. The better the food, the

greater weight, better quality, and more profit, which is generally the case in the feeding of all animals. Some fatten with grains and pollard. Mowbray tried wheat and potato oats comparatively, but could find no difference in the goodness of their flesh. The rabbit's flesh being dry, the allowance of succulent greens may tend to render it more juicy; and probably the old complaint of the dryness of the flesh in Devon beef, entirely fed with hay, might be remedied in the same way. Rabbits are in perfection for feeding at the fourth or sixth month; beyond which period their flesh becomes more dry and somewhat hard. It requires three months, or nearly so, to make a rabbit thoroughly fat and ripe; half the time will make them eatable, but by no means equal in the quality of the flesh: they may yet be over fattened, as appears by specimens exhibited a few years since at Lord Somerville's show, which were loaded with fat, without and within, like the best-feeding sheep.

7359. *The flesh of the rabbit* is esteemed equally digestible as that of fowls, and equally proper for the table of the invalid.

7360. *Castrated rabbits* might be fattened, no doubt, to the weight of upwards of ten pounds, at six or seven months old. It is said to be successfully practised in Sussex, near Chichester, where on the average not one in three hundred is lost by the operation, which is performed at five or six weeks old. With respect to the quantity of corn consumed in fattening, a young buck which weighed three pounds, fit for the spit, was put up in good case in August, and was only one month in feeding, consuming not quite four quarts of oats, with hay, eabbage, lucerne, and ehicory; the skin, silver and black, worth fourpence.

7361. *In slaughtering full-grown rabbits*, after the usual stroke upon the neck, the throat should be perforated upwards towards the jaws with a small-pointed knife, in order that the blood may be evacuated, which would otherwise settle in the head and neck. It is an abomination to kill poultry by the slow and torturing method of bleeding to death, hung up by the heels, the veins of the mouth being cut; but still more so the rabbit, which in that situation utters horrible screams. The entrails of the rabbit, whilst fresh, are said to be good food for fish, being thrown into ponds.

7362. *The rabbit is a caressing animal*, and equally fond with the cat of the head being stroked; at the same time it is not destitute of courage. A whimsical lady admitted a buck rabbit into her house, when he became her companion for upwards of a twelvemonth. He soon intimidated the largest eats so much, by chasing them round the room and darting upon them, and tearing off their hair by mouthfuls, that they very seldom dared to approach. He slept in the lap by choice, or upon a chair or the hearth-rug, and was as full of mischief and trieks as a monkey. He destroyed all the rush-bottomed chairs within his reach, and would refuse nothing to eat or drink which was eaten or drank by any other member of the family.

7363. *Diseases.* No live stock is less liable to disease than the rabbit, with regular and careful attention, such as has been pointed out; so that any sudden and accidental disorder is best and most cheaply remedied by a stroke behind the ears. But want of care must be remedied, if at all, by an opposite conduct, and improper food exchanged for its contrary. Thus, if rabbits become pot-bellied, in the common phrase, from being fed on loose vegetable trash, they must be cured by good hard hay and corn, ground malt or peas, or any substantial or absorbent food. Their common liver complaints are incurable, and when such are put up to fatten, there is a certain criterion to be observed. They will not bear to be pushed beyond a moderate degree of fatness, and should be taken in time, as they are liable to drop off suddenly. The dropsy and rot must be prevented, as they are generally incurable; nor is a rabbit worth the time and pains of a probable cure.

7364. *The hare* (*Lèpus tímídu*s L., fig. 910.), if taken young, may be tamed and domesticated, and has occasionally been

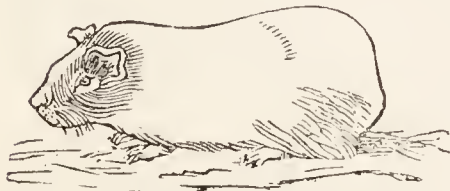


nursed by a cat. Sonnini the naturalist, and Cowper the poet, had hares in a complete state of domestication. As the fur of this animal is of greater value for hat-making than that of the rabbit, it would be a very desirable circumstance if it could be substituted for that animal in warrens. Its flesh would certainly be

deemed preferable, and in general it is a large animal. It lives on the same sort of food as the rabbit, produces generally three young ones at a time, and breeds at least three times in a year. It is not improbable that in some situations, where the soil is dry and poor, a hare warren or pack might be found to answer; the price in the metropolis being never less than ten times that of rabbits.

7365. *There is a hare warren* near Banstead Downs: it contains about three acres of ground: 200 brace are usually kept in it: they are fed in the summer on clover, rape, &c.; and in the winter, on hay. The warren is surrounded by a brick wall about ten feet high, with openings at regular distances, within which are wire gratings on hinges: these give way to the hares, when they enter the warren; and they are so constructed, that they immediately close after them, and so prevent their escape.

7366. *The Guinea pig*, or restless Cavy (*Càvia Cobàya* L., fig. 911.), is a native of Brazil, but domesticated in Europe, and treated and used like the tame rabbit. In Italy, the flesh is considered a delicacy, and the skins are nearly as valuable as those of rabbits.



7367. *The Guinea pig is one of the most prolific* of animals, and Buffon calculates that in twelve months only 1000 might be produced from a single pair, as the female has been known to bring forth young when two months old only: the time of gestation is

only three weeks; and she will produce at least every two months. The young are six or seven months before they arrive at their maturity of growth, but within the short period of twelve hours from their birth are nearly as alert and active as those fully grown, and therefore require parental assiduity only for a little time. Vegetables form their food, and on a great variety of these they will flourish and fatten. They drink but little, appear after eating to ruminate, and are extremely apt to be affected by cold. They are uncommonly clean in their habitations, and are often to be seen smoothing and cleansing their fur with particuliar attention and perseverance.

7368. *The fat dormouse* (*Myóxus Glís* L.) is a native of the woods of Germany and Russia; and has a good deal of the habits of the squirrel. It feeds on fruits, lays up a winter store, forms its nest in hollow trees, sleeps by day, and grows very fat in autumn.

It was cultivated by the Romans, and highly prized by them as food. The body is six inches long.

7369. *Of the deer (Cervus L.)* there are three species in cultivation in this country: the stag, roe, and fallow deer. The latter are now almost exclusively cultivated in parks, as articles of luxury, and, it is conceived, might answer to a small extent in farming.

7370. *The stag (C. Elephas L., fig. 912. a)* is found in nearly all the temperate climates of Europe and

912



Asia. It is also found in North America, but attains its largest size in Siberia. From the branchiness of its antlers, the elegance of its form and movements, and the strength of its limbs, it deservedly attracts particular admiration, and may be regarded as a principal embellishment of the forest. The stag is remarkable for a fine eye, and an acute sense of smelling. His ear also is exquisitely sensible, and musical sounds appear to possess over him the power of exciting complacency, if not rapture. His enemies not unfrequently employ the shepherd's pipe to decoy him to his destruction; and Playford, in his *Introduction to Music*, states that he once met a herd of twenty stags near Royston, which readily followed the tones of a violin and bagpipe, played by their conductors, but stopped whenever the music was suspended. Their whole progress from Yorkshire to Hampton Court was attended, and it was supposed extremely facilitated, by these sounds. The stag is simple and unsuspecting, and employs no arts to avoid detection or pursuit, until after having received considerable molestation. His food consists in winter of moss and bark; in spring, of the catkins of willow and hazel, and the flowers and buds of cornel; in summer, of the grain of rye, and the tender shoots of the alder; in autumn, of the leaves of brambles, and the flowers of heath and broom. He eats with slowness, and ruminates with some considerable effort, in consequence of the distance between the first stomach and the mouth. In March, generally, he sheds his antlers, which are not completely renewed till August. He will live to between thirty and forty years of age, and was formerly, amidst the other vulgar errors of antiquity, supposed capable of attaining most extraordinary duration. The stag is supposed to have been introduced from France into England, where he has latterly been made to give way to the fallow deer, an animal more gentle in its manners, and more valuable as food. In some parts of Scotland he is yet to be found in his original wild state. A stag of five years old is, in hunting, termed a hart; the female, hinds; and the young, fawns.

7371. *The roe (C. Capreolus L., fig. 912. b)* is the smallest of the deer tribes which are natives of Europe; it is generally of a reddish brown colour; graceful, sprightly, and courageous, particularly cleanly, and delighting in dry and mountainous situations: it leaves a strong scent behind it, but possesses such arts of defence, that by various doublings and intermixtures of past with present emanations from its body it frequently baffles the most experienced dogs, and remains in a state of security, while the full pack passes almost close by its retreat, distinguishing it neither by sight nor smell. It differs from the stag in the constancy of its attachment, and the parents and their young constitute a family, never associating with strangers: two fawns are generally produced by the female at a birth, one of each sex, which, living together, form a mutual and invincible attachment. When a new family is to be nursed, the former is driven off to provide for itself, but returns again after a certain interval to the mother, whose former affection is restored: a final separation speedily takes place, however, soon after this return, between the fawns of the season preceding the last and their dam; and the former remove to a distance, constituting a distinct establishment, and rearing an offspring of their own. When the female is about to bring forth, she secludes herself in some remote recess of the forest, from which she returns at the end of about ten days with her fawns, just able slowly and weakly to follow her steps: in cases of danger she hides them in a place deemed by her most secure from the enemy, and attracts the attention of the latter from them to herself; happy, by her own perils or even destruction, to effect the security of her offspring. In winter, these animals feed on brambles, broom, heath, and catkins; and in spring they eat the young wood and leaves of almost every species of tree, and are said to be so affected, as if were with intoxication, by the fermentation of this food in their stomachs, that they will approach men and other enemies (whom they generally shun with great care) without apprehension or suspicion. The flesh of these animals is excellent, though after two years of age that of the males is ill-flavoured and tough. The roe exists now in no part of Ireland, and, in Great Britain, only in a few districts of the Highlands.

7372. *The fallow deer (C. Dama L., fig. 912. c)* is in general much smaller than the stag; but in Spain is nearly equally large. In France and Germany it is rarely to be found, and it has never been known to have existed in America. It has the elegance of the stag, connected with a much more tractable disposition. It sheds its antlers, which, as in the stag species, are peculiar to the male, every year; is stated to live to the age of twenty years, and arrives at its maturity in three; it is by no means fastidious in its food.

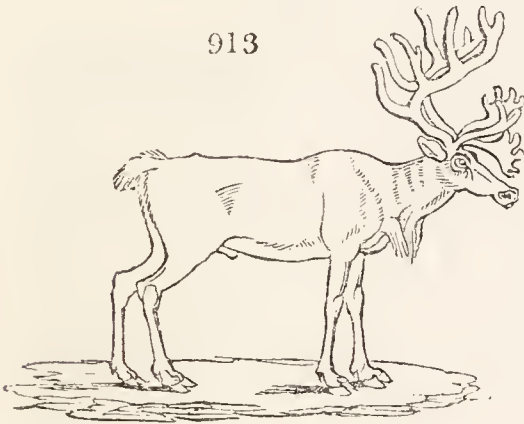
7373. *Deer husbandry.* The author of the *Agricultural Survey of the County of Hertford* observes, that, "the Earl of Clarendon, justly considering that there is no more impropriety in converting one animal to profit than another, makes deer an object of husbandry. As soon as the rutting season is over, or usually about the 10th of November, his lordship selects from the herd the weak ones, some of which would probably die in the winter, and keeps them in a small yard that has a shed on one side, and a net over the whole against pigeons, &c.; the spot very warm, and well sheltered. Their antlers are immediately sawn off, the place is well littered, and they are fed at a very small expense on pea-straw, hay, &c. warmth making up for the want of better food. At times, during the winter, they have clover-hay cut into chaff, and if they do not eat it well, a little salt is added. They have always plenty of water, and are

kept perfectly clean : much attention should, he says, be paid by the keeper to make himself familiar with them, that he may enter the place without disturbing them. The first week in March he gives them oil-cake, about half a cake each a day, with chaff, which fattens them so quickly that all are gone in May. Before killing they have some green meat given, to take away any ill flavour from the cake, supposing such to be the effect of the food; for it is certain that the venison is exceedingly good. As to weight, a haunch usually weighs about 24 pounds; a brace is sold for 15 guineas: the skin, worth 2l. 2s., is the keeper's perquisite; so that the value of a brace amounts to 17l. 17s. exclusive of some trifling articles. The purchaser sends for them." It is added, that his lordship usually fattens nine brace: his whole winter stock rises to 350 head, in a park of 250 acres, but much of it is thickly covered with timber; thirty sheep and ten cows also feed on it. The park consumption of hay amounts to thirty-two loads, being reduced to that quantity by the use of much browse; all ash, elm, and Scotch pine being brought for that purpose before faggoting, which not only saves hay, but improves the flavour of the venison.

7374. *By castrating the males of deer* when newly dropped, which is not in the least dangerous, it affords the means of having good venison until Christmas, without any other sort of food than the common grass: they also fatten more quickly; the operation must, however, be performed while they are quite young. (*Devonshire Report.*)

7375. *The moose deer, or elk* (*Cervus Alces L.*), is indigenous in Europe, America, and Asia, as far as Japan, and was formerly wild in this country, though now extinct. It is of the size of a horse; gentle, except when teased by the gad-fly; feeds on twigs and branches of trees, and marsh plants; goes on its hoofs with a shambling gait at the rate of fifty miles a day; has a skin so hard as almost to resist a musket ball, but flesh tender and good. This animal might be introduced as an inhabitant of parks, where it would add to the variety of animated woody scenery and of venison.

7376. *The rein deer* (*Cervus Tarandus L.*, fig. 913.) is an inhabitant of the alpine mountains of America, Europe, and Asia, and is too remarkable an animal, and too well known, to require a particular description or account of his habits.



913

7377. *The tame variety* have been introduced more than once into this country by the Hon. Daines Barrington, Bullock, and others, but cannot be kept in parks on account of the want of their particular lichen. As this lichen abounds on several mountains in Yorkshire, and on many in Scotland and Ireland, some patriotic and curious noblemen might attempt its cultivation. The milk and cream, as Dr. Clarke states, are most excellent, and also the flesh; and even as an article of profit, the sale of the animals as breeding stock would pay for a time. Lichen hay might no doubt be imported at an easy rate from the gulf of Bothnia; and the animal by degrees in the course of a few generations might be habituated to grass or the spray of trees.

7378. *The antelope* (*Antelope L.*) is a beautiful and numerous genus of animals, partaking of the nature of the goat and deer. Two species, the *A. Saiga*, or scythion, and the *A. Rupicapra* or chamois, are natives of Europe, but the rest of hot climates.

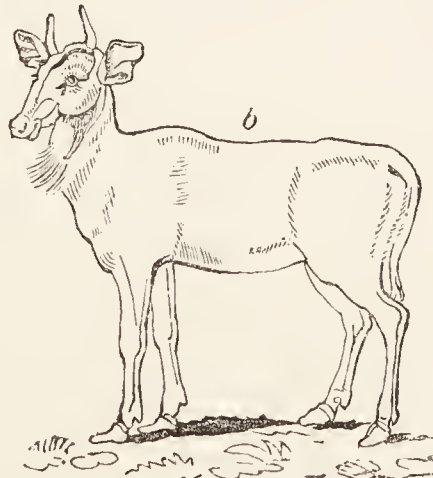
7379. *Antelopes*, Pennant observes, are animals generally of a most elegant and active make, of a restless and timid disposition, extremely watchful, of great vivacity, remarkably swift and agile, and most of their boundings so light and elastic as to strike the spectator with astonishment. What is very singular, they will stop in the midst of their course, gaze for a moment at their pursuers, and then resume their flight. As the chase of these animals is a favourite amusement with the Eastern nations, from that may be collected proofs of their rapid speed. One of the highest compliments that can be paid to female beauty in the Eastern regions is, *Aine el Czazel*, 'You have the eyes of an antelope.' Some species of antelopes form herds of two or three thousand, while others keep in troops of five or six. They generally reside in hilly countries, though some inhabit plains: they often browse like the goat, and feed on the tender shoots of trees, which gives their flesh an excellent flavour.

7380. *The common antelope* (*A. Cervicapra L.*) abounds in Barbary, and in all the northern parts of Africa. It is somewhat less than the fallow deer: its horns are about sixteen inches long, surrounded with prominent rings almost to the top, where they are twelve inches distant from point to point. The horns are remarkable for a beautiful double flexion, which gives them the appearance of the lyre of the ancients. The colour of the hair on the back is brown, mixed with red; the belly and inside of the thighs white; and the tail short.

7381. *The chamois antelope* (*A. Rupicapra*, fig. 914. a) was formerly considered as belonging to the genus *Capra*, and is generally called the chamois goat. It is found on the mountains of Switzerland, where it is very shy, and hunted both for its flesh and skin. (342.)



914



7382. *The Scythian antelope* (*A. Saiga L.*) bears a good deal of resemblance to the common goat, and it is fully as easily tamed. They are found in immense flocks on the banks of Borysthenes and other parts of Russia, where they are valued both for the flesh and their skin, which is equal to that of the chamois for gloves.

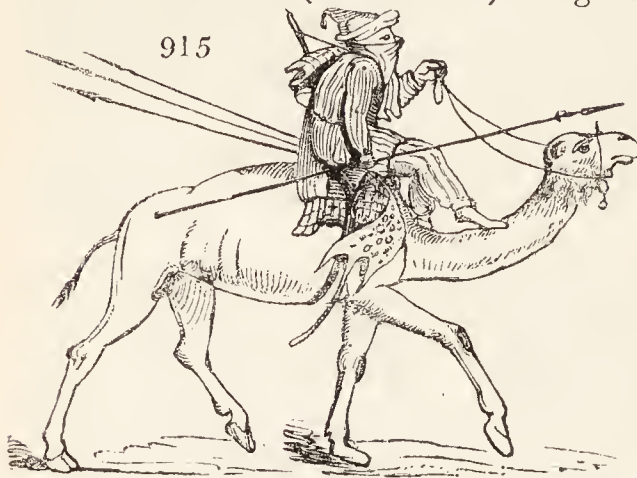
7383. *The nilgau*, or white-footed antelope (*A. picta L.* fig. 914. b), is a large and beautiful species, known only within the space of a few years past. Its height is four feet one

inch to the top of the shoulders; its length, from the bottom of the neck to the base of the tail, four feet; and the colour a fine dark grey. The nilgau has of late years been often imported into Europe, and has bred in England. In confinement, it is generally pretty gentle, but is sometimes seized by fits of sudden caprice, when it will attack with great violence the object of its displeasure. The nilgau is said to go

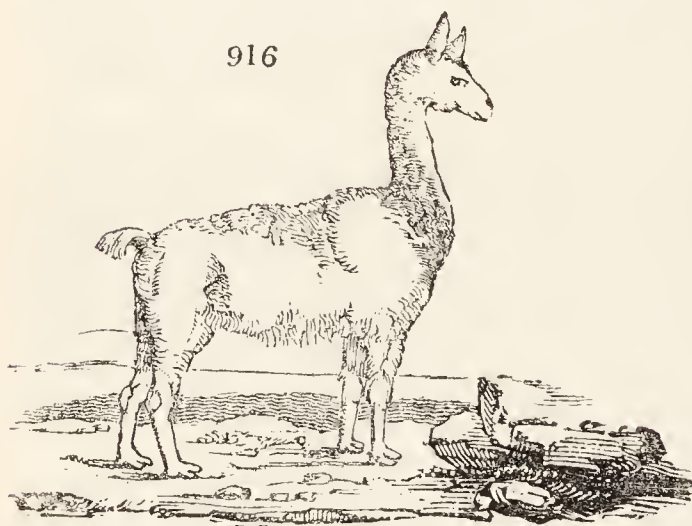
with young about nine months, and to produce sometimes two at a birth: the young is of the colour of a fawn.

7384. The above and various other species of antelopes might probably be acclimated and introduced in parks as objects of luxury. The cultivator who first succeeded in breeding them would find an ample demand at his own price if they happened to come in vogue.

7385. The camel (*Camelus L.*) is a genus of which there are several species, three of which, the dromedary, or Arabian camel (fig. 915.), the Bactrian camel, and the lama or Peruvian sheep, might certainly be partially acclimated in England, as the first is in Italy. (297.) They live upon a very little of the coarsest herbage; might have a warm house well littered to retire to in winter, or in cold nights, and would form a singular ornament to park scenery. Besides their hair and skin are valuable, and they might be sold perhaps to romantic travellers or cavalier quacks.



7386. The lama (*Camelus Glama L.*, fig. 916.) is the camel of South America; and appears to hold a middle place between the sheep, deer, and camel.



7387. Before the entrance of the Spaniards, lamas were the only beasts of burden known to the South Americans. Like camels, they travel slowly, but are persevering, tractable, and very sure-footed. Since the introduction of mules, they are much less cultivated; but before they were depended on to carry the ores dug out of the rich mines of Potosi. The lama is furnished as the camel with ability to abstain from water, by keeping a quantity in its second stomach. Like the camel, its feet also divide, and spread; but by no means equal to those of the camel. It is also furnished with a singular protuberance or spur behind, which enables it the better to lay hold on the ground. The tame are of various colours, and some of them are smooth and others rough. The height of the lama is about four feet, and its length from the neck to the tail about six feet. It has a capacity of throwing out the saliva to a considerable distance, but which is not possessed of any acrid quality.

7388. The camelopard (*Camelopárdalis Giráffa L.*), a most singular and noble animal, seventeen feet high, and as tame and gentle as the camel, might also be naturalised. It lives on the green spray of trees and grass, and frequents forests.

7389. The elephant, rhinoceros, musk ox, and a variety of other exotic domestics, might be so far acclimated as to live in Britain as they do in the *Jardin des Plantes* at Paris, viz., with an enclosure for each sort, and a lodge or house for protection in winter or during inclement weather. Were as much attention paid to acclimating foreign animals as there is directed to the same branch of culture in plants, we should soon possess a rich Fauna; and the public taste may in time take this direction.

7390. In acclimating the more tender animals, it might be desirable to rear a few generations, first in the south of Italy or in Spain, next in France, and afterwards in the south of England. But the camel, musk ox, zebra, quagga, and antelope might be had at once from the acclimated stock in Italy.

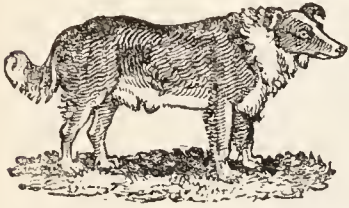
7391. The dog (*Cànis familiàris*) is an animal of universal utility and interest. From the earliest ages he has been the companion and assistant of the herdsman; and without his aid the flocks must have been confined to narrow limits, and consequently their propagation would have been greatly lessened. But hardy and bold, he watched by night, and toiled by day; securing his charge from the human thief, or the ravenous predatory beasts in the one, and collecting and organising their march during the other. Without the dog, sheep-farmers of the present day would be often at a loss to restrain the wanderings of their flocks; nor is he less useful in guarding the yard by nightly watchings.

7392. The genus *Cànis* includes other animals, as the wolf, the fox, the jackal, and the hyæna: and many naturalists have supposed our subject, the dog, to be only a mixed animal, originating from the union of some of these. Such is the opinion of Guldenstadt, Pallas, and Pennant; while the higher names of Blumenbaeh and Cuvier are ranged among those who assign him a distinct and specific origin. Blaine, who has long successfully advocated the cause of the dog, has bestowed much research on this point; and appears clearly to have traced the dog through his numerous varieties, to a specific origin; but whether originating from a specific or a spurious source, the dog has descended down into such innumerable varieties, that a detail of the forms and properties of them, as they appear among us only, would be utterly impossible. The wants as well as the luxuries of man have, however, laid hold on some of these varieties, and have fixed them into permanencies, by confining the sexual intercourse to their congeners alone; and of this number there are no less than forty. It would be unnecessary to draw the character of the dog as stated at length by Linnæus and others; the outlines are the same in all.

7393. *The shepherd's dog*, in an agricultural point of view, ranks foremost among the numerous varieties; indeed, the fanciful Buffon makes him the father of the whole race of dogs. But did no other difficulty arise, an insuperable one would be found in the opposite characters which different breeds of this dog possess. Few animals can be more unlike than the small sheep-dog of the Highlands of Scotland and the monstrous drover's dog of Smithfield.

7394. *The English sheep-dog* (fig. 917.) is usually larger than the northern, is longer on the legs, and has been so long accustomed to have the tail taken off nearly close to the rump, that in some instances the euston has operated on nature; and these dogs are sometimes pupped tailless. The shepherd's dog is not, however, usually bred so large as the real cattle or drover's dog; but is yet sufficiently strong and fierce. Their colour is in general black and white, with half-pricked ears: they are extremely docile and intelligent, and seem almost to understand the looks of the shepherd. Some of them are smooth-coated; but by far the greater number are rough, and have their hair erisped, which enables them better to bear the effects of continued exposure. The dog very erroneously described by minor naturalists as the *cur dog* is nothing more than the shepherd's dog, confined principally to the operations of the farm; and often bred taller, and either smooth or rough, according to circumstances. The

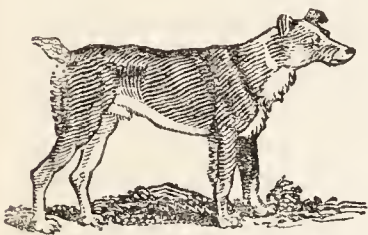
917



very term *cur* destroys all individuality of breed; it being applied to characterise any dog of spurious origin: neither in these farm-yard dogs is any characteristic difference whatever observed in forms, qualities, or uses. When the sheep-dog is generally employed in watching the farm-yard, he becomes more fierce and active; he accommodates his powers to the particular circumstances required of him; he knows every field, and every beast, and keeps the whole in subjection. His bite is keen, and principally directed at the heels of cattle, by which he keeps himself safe, and does not injure them.

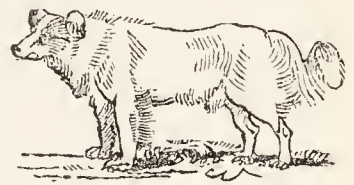
7395 *The sheep-dogs of Scotland* are varied in form and size (figs. 918. and 919.), but are all of them usually smaller than those in use in England: they are, nevertheless, without competitors in sagacity and excellence. Their general characters are, ears partially upright, head

918



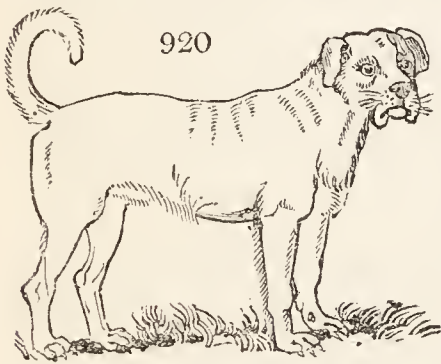
rather pointed, shaggy coat, and a remarkable villosity or fulness of tail beneath. Immense flocks of sheep may be seen ranging the wilds, without other control save the shepherd and his dog, which receives his commands, executes them, and then waits for further instructions: or he often acts with great judgment and promptitude from the impulses of his own sagacity, in which, perhaps, these dogs never shine more than in their readiness to distinguish the individuals of their own flocks, and their adroitness in keeping out intruders. In driving a number of sheep to any distance, a well trained dog never fails to confine the sheep to the road: he watches every avenue that leads from it, where he takes his stand, threatening every delinquent; and pursues the stragglers, forcing them into the ranks without doing them any injury. If the herdsman be at any time absent, he rests satisfied, knowing his dog will not abandon his charge, but will keep them together; and the moment he returns, the sagacious animal gives up his trust, or conducts them to his master, according to the word or signal given.

919



7396. *The mastiff or guard* (fig. 920.) is a noble animal, derived from the Dane; but by selection and cultivation is rendered thicker and heavier, though less tall than his original. The powers of this dog are immense; and as a guard he is unrivalled; having the ferocity of a tiger to a stranger, with the gentleness of a lamb towards those he knows. His sagacity in detecting the attempts of robbers, and his fidelity in resisting all their bribes, are such, that it is to be lamented his breed has given place to that of the Newfoundland dog, whose qualities as a guard are certainly not equal to his. The mastiff is characterised by small pendulous ears, smooth coat, colour various, often reddish or brindled. The lips are pendulous, jaws of immense strength, but seldom underhung; and his general form is symmetrical for strength.

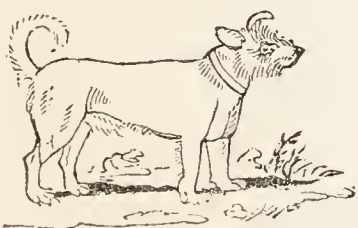
920



7397. *The bull-dog* can no otherwise be considered as connected with agriculture, than as he is too often used in the disgraceful and inhuman sport of bull-baiting: and however we may admire his invincible fortitude, and his contempt of pain and danger, we must allow him to be the most useless among the dog species. In his attack on cattle he always aims at the front, and generally fastens on the upper lip, where he will hang in spite of every effort of the animal to disengage himself.

7398. *The terrier* (fig. 921.) is a dog of very great utility, and of very varied form and size. His qualities have gained him the greatest care in selection, training, and continuing the numerous distinct breeds we witness. The principal varieties may be reduced into the rough and the smooth breeds. The *rough breed* is originally derived from Scotland, where it is still preserved in a few families in its original purity. These specimens are seldom large, but are exceedingly rough and shaggy in their hair, which is much crisped and brindled. The rough breed in England has become larger, and is very often seen white. When mixed with the bull breed, this terrier becomes fierce, much inclined to combat, and forms an excellent guard. The *smooth breed* produces endless varieties; the principal of which is an elegant black animal with tan markings. A second variety is of varied colours, smaller, thicker, and longer; and is used for earthing foxes, badger-baiting, and vermin killing in general.

921



For rabbit hunting, a wry-legged breed is in considerable request. Although particular varieties are often appropriated to particular purposes, yet all have a common property which renders them invaluable to the agriculturist; which is their determined hostility to those animals termed vermin, as foxes, otters, badgers, polecats; with rats and mice. To attack the former, they are bred strong, and have a portion of the bull breed in them: for the latter, their hardihood, activity, and keenness of gripe are particularly studied, in which the middle-sized breeds are frequently found to excel.

7399. *The pointer, setter, and spaniel* (fig. 922.) it might seem at the first view unnecessary to introduce to the notice of the agriculturist; but a little examination of the subject will show that they may be made an object of considerable importance to the farmer. Few dogs command such prices as sporting dogs; and few persons have such opportunities of rearing them so cheaply, or so well, as farmers. Many farmers shoot game; most of them do it more or less: and it would be very easy to make two brace of pointers or setters, with one or two brace of spaniels, pay a considerable part of the rent of the farm, without other expense than skim-milk and potatoes, or occasionally a little barley meal. We will suppose that a farm has on it three pointer bitches, and one pointer dog, all of acknowledged excellence, and two out of the three bitches may be expected to go to heat early, and to produce progeny between the seasons of shooting, when they are wanted: from these, four brace of puppies may be saved, and by continually following the servants and their master, they will become so handy, that their breaking may be effected

daily, and without any other trouble than what occurs in restraining them when a little wild. If their breed is very good, their stopping and backing will commence towards the end of the first season, and dur-



ing the periods between this and the next autumn they may be steadied and practised in fetching their game, &c., as directed in good sporting works. At the commencement of the following season, if they have been well attended to, although only fifteen months old, the whole may be sold to the London or country dealers, to average six or seven guineas each: or if sold privately, they will fetch from eight to twelve and fifteen guineas each, out of which, perhaps, not more than half a guinea can fairly be deducted for keep, &c. The trouble occasioned to the master will be trifling, because connected with a pleasing employ to him as a sportsman, and who will thus have his own sporters for nothing.

7400. *Setters*, as more valuable, will fetch a higher price; but they do not always command so ready a sale, and are more troublesome to break.

7401. *Spaniels* are commonly thought, but most erroneously, almost to break themselves. A really well broke spaniel, however, is so rare, that instead of being worth two or three guineas, which is the usual price, it will fetch from five to ten pounds. It would be even less difficult to the farmer to rear spaniels than pointers; and by following him continually about the grounds they might be taught perfect obedience, and close rangings, which are the grand requisites, without trouble or expense. In this way, four or five brace might be easily brought every season to market, and would always command a ready sale, and a price according to the perfection of their breaking.

7402. *In the breeding and rearing* of dogs for the above purposes, it is necessary to observe the greatest care in their original selection; that the breed be of the very best, and one which as it were breaks itself, for this shows the purity of the breed. It is likewise no less necessary that the breed be carefully preserved so; to do which, the moment the dogs begin to smell at a bitch, shut her and the intended male closely up, in a confinement inaccessible to other dogs, and there let them remain a fortnight. It is likewise almost equally necessary, that the dogs peculiarly appropriated to agriculturists, particularly the shepherd's dog, should be bred as pure; for no animal is more liable to sport into varieties. No crossing can on any account be permitted; but choice may be made among families of the same variety. In the rearing of this dog, his education should be early and carefully attended to, to make him hardy and familiar with all the signs of the shepherd, who ought himself to be equal to the regular education of his own dog.

7403. *The diseases of dogs* are very numerous. The following are described by Blaine as the most prevalent, with their methods of cure.

7404. *The canine asthma* is hardly ever observed to attack any but either old dogs, or those who, by confinement, too full living, and want of exercise, may be supposed to have become diseased by these deviations from a state of nature. It is hardly possible to keep a dog very fat for any great length of time, without bringing it on. This cough is frequently confounded with the cough that precedes and accompanies distemper; but it may be readily distinguished from this by an attention to circumstances, as the age of the animal, its not affecting the general health, nor producing immediate emaciation, and its less readily giving way to medicine.

7405. *The cure* is often very difficult, because the disease has in general been long neglected before it is sufficiently noticed by the owners. As it is usually brought on by confinement, too much warmth, and over-feeding; so it is evident the cure must be begun by a steady persevering alteration in these particulars. The medicines most useful are alteratives, and of these occasional emetics are the best. One grain of tartarised antimony (*i. e.* tartar emetic), with two, three, or four grains of calomel, is a very useful and valuable emetic. This dose is sufficient for a small dog, and may be repeated twice a week with great success, — always with palliation.

7406. *Of diseases of the eyes*, dogs are subject to almost as great a variety as ourselves, many of which end in blindness. No treatment yet discovered will remove or prevent this complaint.

7407. *Sore eyes*, though not in general ending in blindness, is very common among dogs. It is an affection of the eyelids, is not unlike the scrofulous affection of the human eyelids, and is equally benefited by the same treatment: an unguent made of equal parts of nitrated quicksilver ointment, prepared tutty and lard, very lightly applied. Dropsy of the eyeball is likewise sometimes met with, but is incurable.

7408. *Cancer*. The virulent dreadful ulcer, that is so fatal in the human subject and is called cancer, is unknown in dogs; yet there is very commonly a large scirrhus swelling of the teats in bitches, and of the testicles (though less frequent) in dogs, that as it sometimes becomes ulcerated, so it may be characterised by this name. In the early state of the disease discutients prove useful, as vinegar with salt, and camphor and Spanish flies, with mercurial ointment, have sometimes succeeded; taking care to avoid irritating the part so much as to produce blister. But when the swelling is detached from the belly, and hangs pendulous in the skin, it had better be removed, and as a future preventive suffer the bitch to breed. Scirrhus testicles are likewise sometimes met with; for these no treatment yet discovered succeeds but the removal of the part, and that before the spermatic chord becomes much affected, or it will be useless.

7409. *Colic*. Dogs are subject to two kinds of colic; one arising from constipation of the bowels, the other is of a kind peculiar to dogs, apparently partaking of the nature of rheumatism, and also of spasm. From a sudden or violent exposure to cold, dogs become sometimes suddenly paralytic, particularly in the hinder parts; having great tenderness and pain, and every appearance of lumbago. In every instance of this kind, there is considerable affection of the bowels, generally costiveness, always great pain. A warm bath, external stimulants, but more particularly active aperients, remove the colic. Colic arising from costiveness is not in general violently acute from the pain it produces; sometimes, however, it appears accompanied with more spasm than is immediately dependent on the confinement of the bowels. In the former give active aperients, as calomel with pil. cœchiæ, *i. e.* aloetic pill and glysters; in the latter castor oil with laudanum and ether.

7410. *Cough*. Two kinds of cough are common among dogs, one accompanying distemper, the other in an asthmatic affection of the chest. (See 7404. 7411.)

7411. *Distemper*. This is by far the most common and most fatal among the diseases of dogs; hardly any young dog escaping it; and of the few who do escape it in their youth, three fourths are attacked with it at some period afterwards: it being a mistake that young dogs only have it. It, however, generally

attacks before the animal arrives at eighteen months old. When it comes on very early, the chances of recovery are very small. It is peculiarly fatal to greyhounds, much more so than to any other kind of dog, generally carrying them off by excessive scouring. It is very contagious, but it is by no means necessary that there should be contagion present to produce it; on the contrary, the constitutional liability to it is such, that any cold taken may bring it on: and hence it is very common to date its commencement from dogs being thrown into water, or shut out on a rainy day, &c. There is no disease which presents such varieties as this, either in its mode of attack, or during its continuance. In some cases it commences by purging, in others by fits. Some have cough only, some waste, and others have moisture from the eyes and nose, without any other active symptom. Moist eyes, dulness, wasting, with slight cough and sickness, are the common symptoms that betoken its approach. Then purging comes on, and the moisture from the eyes and nose from mere mucus becomes pus, or matter. There is also frequently sneezing, with a weakness in the loins. When the disease in this latter case is not speedily removed, universal palsy comes on. During the progress of the complaint, some dogs have fits. When one fit succeeds another quickly, the recovery is extremely doubtful. Many dogs are carried off rapidly by the fits, or by purging; others waste gradually from the running from the nose and eyes, and these cases are always accompanied with great marks of putridity.

7412. *The cure.* In the early stages of the complaint give emetics; they are peculiarly useful. A large spoonful of common salt, dissolved in three spoonfuls of warm water, has been recommended; the quantity of salt being increased according to the size of the dog, and the difficulty of making him vomit: while a dog remains strong, one every third day is not too much. The bowels should be kept open, but active purging should be avoided. In case the complaint should be accompanied with excessive looseness, it should be immediately stopped by balls made of equal parts of gum arabic, prepared chalk, and conserve of roses, with rice milk as food. Two or three grains of James's powder may be advantageously given at night, in cases where the bowels are not affected; and in the cases where the matter from the nose and eyes betokens much putridity, we have witnessed great benefits from balls made of what is termed Friar's balsam, gum guaiacum, and chamomile flowers in powder: but the most popular remedy is a powder prepared and vended under the name of distemper powder, with instructions for the use of it. Dogs, in every stage of the disease, should be particularly well fed. A seton we have not found so useful as is generally supposed: where the nose is much stopped, rubbing tar on the upper part is beneficial; and when there is much stupidity, and the head seems much affected, a blister on the top is often serviceable.

7413. *Fits.* Dogs are peculiarly subject to fits. These are of various kinds, and arise from various causes. In distemper, dogs are frequently attacked with convulsive fits, which begin with a champing of the mouth and shaking of the head, gradually extending over the whole body. Sometimes an active emetic will stop their progress, but more generally they prove fatal. *Worms* are often the cause of fits in dogs. These deprive the animal wholly of sense; he runs wild till he becomes exhausted, when he gradually recovers, and perhaps does not have one again for some weeks. Confinement produces fits and likewise costiveness. Cold water thrown over a dog will generally remove the present attack of a fit; and for the prevention of their future recurrence, it is evident that the foregoing account of causes must be attended to.

7414. *Inflamed bowels.* Dogs are very subject to inflammation of their bowels, from costiveness, from cold, or from poison. When inflammation arises from costiveness it is in general very slow in its progress, and is not attended with very acute pain, but it is characterised by the want of evacuation and the vomiting of the food taken, though it may be eaten with apparent appetite. In these cases the principal means to be made use of are, the removal of the constipation by active purging, clysters, and the warm bath. Calomel with aloes forms the best purge. But when the inflammation may be supposed to arise from cold, then the removing of any costiveness that may be present is but a secondary consideration. This active kind of inflammation is characterised by violent panting, total rejection of food, and constant sickness. There is great heat in the belly, and great pain; it is also accompanied with great weakness, and the eyes are very red. The bowels should be gently opened with clysters, but no aloes or calomel should be made use of. The belly should be blistered, having first used the warm bath. When the inflammation arises from poison, there is then constant sickness; the nose, paws, and ears are cold; and there is a frequent evacuation of brown or bloody stools. Castor oil should be given, and clysters of mutton broth thrown up; but it is seldom any treatment succeeds.

7415. *Inflamed lungs.* Pleurisy is not an uncommon disease among dogs. It is sometimes epidemic, carrying off great numbers. Its attack is rapid, and it generally terminates in death on the third day, by a great effusion of water in the chest. It is seldom that it is taken in time; when it is, bleeding is useful, and blisters may be applied to the chest.

7416. *Madness.* The symptoms of madness are concisely summed up by Daniel, in the following words:—"At first the dog looks dull, shows an aversion to his food and company, does not bark as usual, but seems to murmur; is peevish and apt to bite strangers; his ears and tail droop more than usual, and he appears drowsy: afterwards he begins to loll out his tongue and froth at the mouth, his eyes seeming heavy and watery. If not confined he soon goes off, runs panting along with a dejected air, and endeavours to bite any one he meets. If the mad dog escapes being killed, he seldom runs above two or three days, when he dies exhausted with heat, hunger, and disease." As this is a subject of no slight importance, we shall stand excused for introducing the criteria as described by Blaine, whose account of the disease, founded on long experience and attentive observation, is calculated to remove many unfounded and dangerous prejudices relative to it. He describes it as commencing sometimes by dulness, stupidity, and retreat from observation; but more frequently, particularly in those dogs which are immediately domesticated around us, by some alteration in their natural habits; as a disposition to pick up and swallow every minute object on the ground; or to lick the parts of another dog incessantly; or to lap his own urine, &c. About the second or third day the disease usually resolves itself into one of two types. The one is called raging, and the other dumb madness. These distinctions are not, however, always clear; and to which is owing so much discrepancy in the accounts given by different persons of the disease.

7417. *The raging madness,* by its term, has led to an erroneous conclusion, that it is accompanied with violence and fury; which, however, is seldom the case: such dogs are irritable and snappish, and will commonly fly at a stick held to them, and are impatient of restraint: but they are seldom violent except when irritated or worried. On the contrary, till the last moment they will often acknowledge the voice of their master and yield some obedience to it. Neither will they usually turn out of their way to bite human beings; but they have an instinctive disposition to do it to dogs; and in a minor degree to other animals also: but, as before observed, they seldom attack mankind without provocation.

7418. *Dumb madness* is so called because there is seldom any barking heard, but more particularly because the jaw drops paralytic, and the tongue lolls out of the mouth, black, and apparently strangulated. A strong general character of the disease is, the disposition to scratch their bed towards their belly; and equally so is the general tendency to eat trash, as hay, straw, wood, coals, dirt, &c.: and it should be remembered, that this is so very common and so invariable, that the finding these matters in the stomach after death, should always render a suspicion formed of the existence of the disease confirmed into certainty. Blaine is also at great pains to disprove the notion generally entertained, that rabid dogs are averse from water; and neither drink nor come near it. This error he contends has led to most dangerous results; and is so far from true, that mad dogs from their heat and fever are solicitous for water, and lap it eagerly. When the dumb kind exists in its full force, dogs cannot swallow what they attempt to lap; but still they will plunge their heads in it, and appear to feel relief by it: but in no instance out of many hundreds did he ever discover the smallest aversion from it. He lays very great stress on the noise made by

rabid dogs, which he says is neither a bark nor a howl, but a tone compounded of both. It has been said by some that this disorder is occasioned by heat or bad food, and by others that it never arises from any other cause but the bite. Accordingly this malady is rare in the northern parts of Turkey, more rare in the southern provinces of that empire, and totally unknown under the burning sky of Egypt. At Aleppo, where these animals perish in great numbers, for want of water and food, and by the heat of the climate, this disorder was never known. In other parts of Africa, and in the hottest zone of America, dogs are never attacked with madness. Blaine knows of no instance of the complaint being cured, although he has tried, to their fullest extent, the popular remedies of profuse bleedings, strong mercurial and arsenical doses, vinegar, partial drowning, nightshade, water plantain, &c. ; he therefore recommends the attention to be principally directed towards the prevention of the malady.

7419. *The preventive treatment of rabies or madness* is, according to Blaine, always an easy process in the human subject, from the immediate part bitten being easily detected; in which case the removal of the part by excision or cautery is an effectual remedy. But, unfortunately for the agriculturist, it is not easy to detect the bitten parts in cattle, nor in dogs; and it would be therefore most desirable if a certain internal preventive were generally known. Dr. Mead's powder, the Ormskirk powder, sea-bathing, and many other nostrums are deservedly in disrepute; while a few country medicines, but little known beyond their immediate precincts, have maintained some character. Conceiving that these must all possess some ingredient in common, he was at pains to discover it; and which he appears to have realised by obtaining among others the composition of Webb's Watford drink. In this mixture, which is detailed below, he considers the active ingredient to be the *Búxus* or box, which has been known as a prophylactic as long as the times of Hippocrates and Celsus, who both mention it. The recipe detailed below has been administered to nearly three hundred animals of different kinds, as horses, cows, sheep, swine, and dogs; and appears to have succeeded in a very great majority of the cases, where it was fairly taken and kept on the stomach. It appears also to have strong prophylactic powers in the human subject; but as it would be most imprudent to trust to it alone, where excision can be practised, so it will be long before the extent of such power can be ascertained in man. The box preventive is thus directed to be prepared:—

Take of the fresh leaves of the tree-box 2 ounces,
of the fresh leaves of rue - - 2 ounces,
of sage - - - - - ½ ounce.

Chop these fine, and boil in a pint of water to half a pint; strain carefully, and press out the liquor very firmly; put back the ingredients into a pint of milk, and boil again to half a pint; strain as before; mix both liquors, which forms three doses for a human subject. Double this quantity is proper for a horse or cow. Two thirds of the quantity is sufficient for a large dog; half for a middling-sized, and one third for a small dog. Three doses are sufficient, given one on each of three subsequent mornings fasting; the quantity directed being that which forms these three doses. As it sometimes produces strong effects on dogs, it may be proper to begin with a small dose; but in the case of dogs we hold it always prudent to increase the dose till effects are evident, by the sickness, panting, and uneasiness of the dog. In the human subject, where this remedy appears equally efficacious, we have never witnessed any unpleasant or active effects; neither are such observed in cattle of any kind. About forty human beings have taken this remedy, and in every instance it has succeeded equally as with animals: but candour obliges us to notice, that in the major part of these, other means were used, as the actual or potential cautery; but in most of the animals other means were purposely omitted. That this remedy, therefore, has a preventive quality, is unquestionable, and now perfectly established; for there was not the smallest doubt of the animals mentioned either having been bitten, or of the dog being mad that bit them, as great pains were in every instance taken to ascertain these points.

7420. *To prevent canine madness* Pliny recommends worming of dogs; and from his time to the present it has had, most deservedly says Daniel, its advocates. He tells us that he has had various opportunities of proving the usefulness of this practice, and recommends its general introduction. Blaine, on the contrary, asserts, that the practice of worming is wholly useless and founded in error; that the existence of any thing like a worm under the tongue is incontestably proved to be false; and that what has been taken for it is merely a deep ligature of the skin, placed there to restrain the tongue in its motions. He also observes, that the pendulous state of the tongue in what is termed dumb madness, with the existence of a partial paralysis of the under jaw by which they could not bite, having happened to dogs previously wormed, has made the inability to be attributed to this source, but which is wholly an accidental circumstance, and happens equally to the wormed and unwormed dog.

7421. *Mange*. This is a very frequent disease in dogs, and is an affection of the skin, either caught by contagion or generated by the animal. The scabby mange breaks out in blotches along the back and neck, and is common to Newfoundland dogs, terriers, pointers, and spaniels, and is the most contagious. The cure should be begun by removing the first exciting cause, if removable; such as filth or poverty, or, as more general the contrary (for both will equally produce it), too full living: then an application should be made to the parts, consisting of sulphur and sal ammoniac; tar-lime-water will also assist. When there is much heat and itching, bleed and purge. Mercurials sometimes assist, but they should be used with caution; dogs do not bear them well.

7422. *Worms*. Dogs suffer very much from worms, which, as in most animals so in them, are of several kinds; but the effects produced are nearly similar. In dogs having the worms the coat generally stares; the appetite is ravenous, though the animal frequently does not thrive; the breath smells; and the stools are singular, sometimes loose and flimsy, at others hard and dry: but the most evil they produce is occasional fits, or sometimes a continued state of convulsion, in which the animal lingers some time, and then dies: the fits they produce are sometimes of the violent kind; at others they exhibit a more stupid character, the dog being senseless and going round continually. The cure consists, while in this state, in active purgatives, joined with opium and the warm bath; any rough substance given internally acts as a vermifuge to prevent the recurrence.

7423. *The worming* of whelps is performed with a lancet, to slit the thin skin which immediately covers what is called the worm; a small awl is then to be introduced under the centre of the worm to raise it up; the farther end of the worm will, with very little force, make its appearance, and with a cloth taking hold of that end, the other will be drawn out easily. The advocates for worming direct that care should be taken that the whole of the worm comes away without breaking; and it rarely breaks, unless cut into by the lancet or wounded by the awl.

7424. *The cat* (*Félis Catus L.*) is distinguished from the lion, tiger, leopard, and others of the genus *Félis*, by its annulate tail.

7425. *Its habits* are thus given by Linnæus:—“Inhabits woods of Europe and Asia; domesticated every where; when tranquil purrs, moving the tail; when irritated is very active, elicits, spits, emits a fetid odour; eyes shine at night, the pupil by the day a perpendicular line, by night large, round; walks with its claws drawn in; drinks sparingly; urine of the male corrosive; breath fetid; buries its excrements; makes a horrid mewling in its amours; mews after and plays with its kittens; wags its tail when looking after prey; the lion of mice, birds, and the smaller quadrupeds; peaceful among its tribe; eats flesh and fish; refuses hot or salted things and vegetables; washes behind its ears before a storm; back electric in the dark; when thrown up, falls on its feet; is not infested with fleas; gravid sixty-three days; brings three to nine young, blind nine days; delights in marum, cat-mint, and valerian.”

7426. *The cat is of great use in the farmery* in catching mice, rats, and even birds. It is most desirable to keep males, as where females are kept the noisy gallantry of the adjoining tom-cats is exceedingly annoying.

7427. *The Genet cat (Viverra Genetta)* is a species of weasel, with an annulate tail and spotted blackish lawny body. It is a native of Asia, Spain, and France; is mild and easily tamed; and answers all the purposes of a cat at Constantinople and other places.

7428. *The ferret (Mustela Furo L., fig. 923.)* is an animal of the weasel and polecat kind, distinguished by its red fiery eyes.



7429. *It is a native of Africa*, but is tamed in Europe for the purpose of catching rabbits. It procreates twice a year, is gravid six weeks, and brings from six to eight young; smells very fetid. The ferret is very susceptible of cold, and must be kept in a box provided with wool or other warm materials, and may be fed with bread and milk. Its sleep is long and profound, and it awakes with a voracious appetite, which is most highly gratified by the blood of small and young animals. Its enmity to rats and rabbits is unspeakable, and when either

are, though for the first time, presented to it, it seizes and bites them with the most frenzied madness. When employed to expel the rabbit from its burrows it must be muzzled, as otherwise it will suck the blood of its victim and instantly fall into a profound sleep, from which it will awake only to the work of destruction, committing in the warren, where it was introduced only for its services, the most dreadful waste and havoc. It is possessed of high irritability, and when particularly excited is attended with an odour extremely offensive.

CHAP. IX.

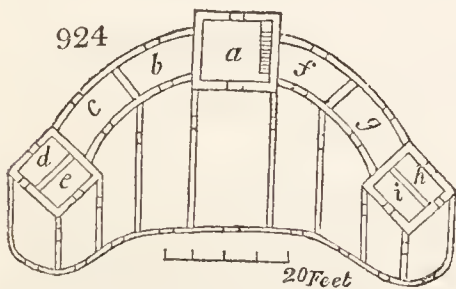
Animals of the Bird kind employed in Agriculture.

7430. *Though poultry form a very insignificant part of the live stock of a farm, yet they ought not to be altogether despised.* In the largest farm a few domestic fowls pick up what might escape the pigs and be lost; and on small farms and among cottagers, the breeding and rearing of early chickens and ducks, and in some situations the rearing of turkeys and the keeping of geese, are found profitable. There are few who do not relish a new egg or a pancake, not to say the flesh of fowls; and there are some of these comforts which happily can be had in as great perfection in the cottage as in the palace. The various kinds of domestic fowls and birds which are used in agriculture may be classed as gallinaceous, or with cleft feet; anserine, or web-footed; and birds of fancy or luxury. Before proceeding to the first division we shall offer some remarks on poultry hovels.

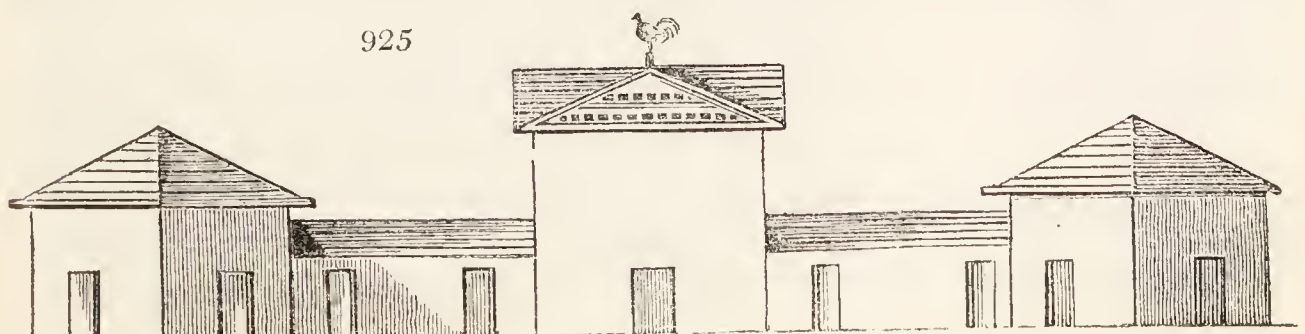
SECT. I. *Poultry Houses and their Furniture and Utensils.*

7431. *The situation of the poultry house should be dry, and exposed either to the east or south-east, so as to enjoy the sun's rays in winter as soon as he appears above the horizon.* Though in many cases all the commoner sorts of poultry are lodged in the same apartment; yet to be able to bestow on each species its proper treatment, they ought to be separated by divisions, and enter by separate doors. Apartments for aquatic fowls may be made in part under those of the gallinaceous tribe, and the peacock often prefers roosting on a tree, or on the roof of high buildings, when it forms an excellent watch bird to the poultry-yard or farmery.

7432. *Where a complete set of poultry houses are intended, then a situation should be fixed on near or close to the farmery, and with ample space around for the fowls to disperse over in the day-time, and one or more ponds for the aquatic sorts.* A space thirty feet by fifty feet may be made choice of for the buildings and yard (fig. 924); the building may be ranged along the north side, and the three other sides enclosed with a trellis or wire fence from six to eight feet in height, and subdivided with similar fences according to the number of apartments. The hen-house (a) and turkey-house (b) may have their roosts (c c) in part over the low houses for ducks (d) and geese (e), and besides these there may be other apartments (f, g, h) for hatching or newly hatched broods, for fattening, to serve as an hospital, or for retaining, boiling, or otherwise preparing food, killing poultry, and other purposes. A flue may pass through the whole in moist or very severe weather; the walls should be built hollow in the manner already described (7002.), which will at the same time be a saving of material; and the windows ought to have outside shutters, both for excluding excessive heats and excessive colds. In



every apartment there ought to be a window opposite the door, in order to create a thorough draught when both are opened, and also a valve in the roof to admit the escape of the hottest and lightest air. Every door ought to have a small opening at bottom, for the admission of the fowls when the door is shut. The elevation (fig. 925.) should be in a simple style, and there may be a pigeonry over the central building.



7433. In ordinary cases, where poultry are kept on a farm merely to consume what would otherwise be lost, one or two compartments of the low range of buildings on the south side of the yard are usually devoted to them, or any dry convenient place, according to the general plan of the farmery.

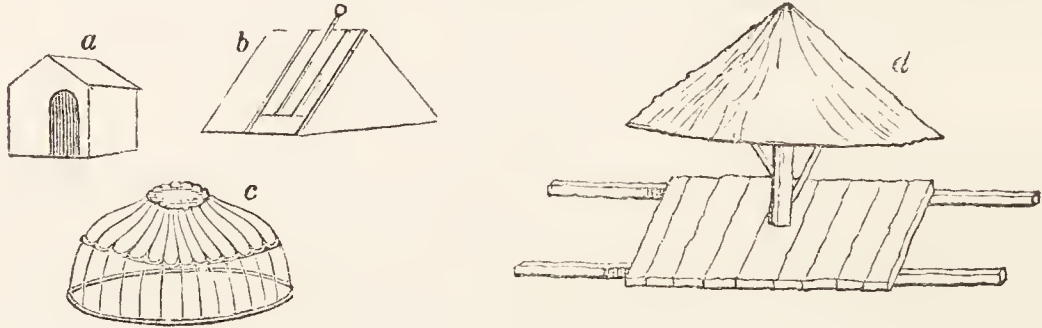
7434. The furniture or fixtures of the poultry houses are very few; the roost is sometimes a mere floor or loft, to which the birds fly up or ascend by a ladder; at other times it is nothing more than the coupling timbers of the roof, or a series of cross battens: but the most approved mode is a series of rough polygonal or angular battens or rods rising in gradation from the floor to the roof, as already explained (2840. and 2842.); the battens placed at such a distance horizontally, as that the birds when roosting may not incommode each other by their droppings. For this purpose they should be a foot apart for hens, and eighteen inches apart for turkeys. The slope of the roost may be about 45° , and the lower part should lift up by hinges in order to admit a person beneath to remove the dung. No flying is requisite in the case of such a roost, as the birds ascend and descend by steps.

7435. Nests are sometimes fixtures, in which case they are niches built against the wall, not unlike wine bins; where there is more than one tier on the ground floor, each superincumbent range must have a projecting balcony in front of about a foot in width, with stairs of ascent at convenient distances.

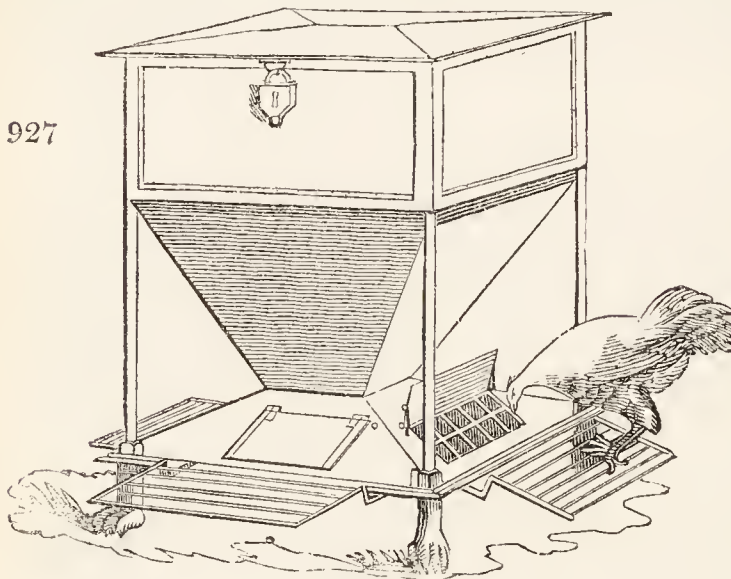
7436. A small boiler for preparing food may sometimes be requisite, though on a small scale this may be done in the kitchen. Watering troughs are generally fixed in the yards. In confined situations there should be a large cistern of sand, in which the fowls may nestle and roll about in order to free themselves from vermin; there should also be a spot composed of gravel, sand, and soft earth, for nearly the same purpose, but more especially for exercising the young chickens. A roof for shelter and protection from the sun may very appropriately be placed over this last compartment, or a part of it.

7437. The utensils are the portable nest, (fig. 926. a), coops (b c), portable shelter (d); feeding dishes,

926



corn bin for retaining a store of food, egg basket, and feather bags. We avoid enumerating the utensils used in cramming, considering that unwholesome and disgusting practice as unfit for the present age.



927

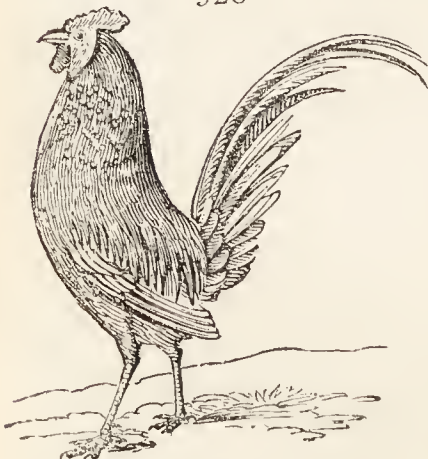
An improved poultry feeder (fig. 927.) has lately been published in the *Transactions of the Highland Society*. It is made to hold half a quarter of grain, not one particle of which can be lost. When once filled, it requires no more trouble, as the grain falls down into the receiver below, as the fowls pick it away; and the covers on that, which are opened by perches, and the iron cover above, which is secured by a padlock, completely keep the grain from the rain, so that the fowls get it always quite dry; and as nothing less than the weight of a hen on a perch can lift a cover on the lower receiver, sparrows, and other small birds, are completely excluded, whilst the small cross bars through which the fowls pick prevent cattle and other large animals from getting at the grain. It is astonishing with what facility the fowls learn to leap upon the perch, and so open the cover of the receiver which covers the grain.

SECT. II. Gallinaceous Fowls, their Kinds, Breeding, Rearing, and Management.

7438. Under the order *Gallinæ* are included the common hen, turkey, Guinea, and peacock; and we shall here treat of each of these birds in succession.

7439. The different species of fowls, that is, of cocks and hens, inhabit in their native state the continent and islands of Asiatic India. Naturalists have not agreed whether these numerous varieties of this most useful bird, seen in a domesticated state, have originated from one or from two species. M. Temminck considers the Bankiva cock (*Gallus Bankiva*) as the origin of our domestic poultry; while others think they may have sprang from the Jungle cock (fig. 928. *G. Sonneratii*), still found in the greatest plenty in the forests of India. The term chicken is applied to the female young of gallinaceous animals till they are four months old; afterwards they are called pullets, till they begin to lay, when they become hens. The male is a chicken till he is three months old, then he is a cock bird till the age of twelve months, when he becomes a cock; unless, indeed, he has been artificially deprived of the faculty of procreation, when he becomes a capon; and when the ovarium is taken from a pullet or hen, she is called a hen capon.

928

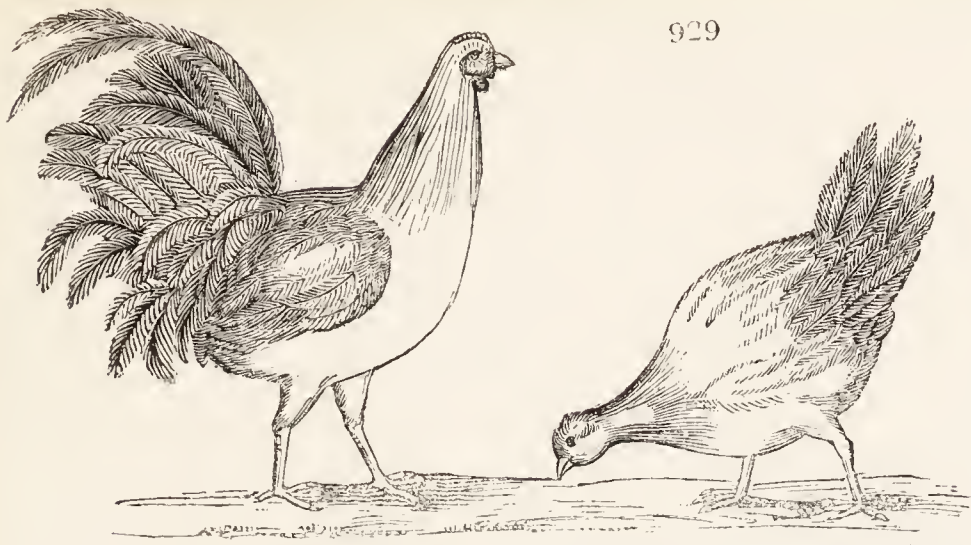


7440. The varieties of a bird so long under culture may naturally be expected to be numerous; those most esteemed in Britain, at the present time, are the following:—

7441. The common dunghill cock and hen, middle size, of every colour, and hardy.

7442. The game cock and hen (fig. 929.), rather small in size, delicate in limb, colour generally red or brown; flesh white, and su-

perior to that of any other variety for richness and delicacy of flavour; eggs small, fine shaped, and extremely delicate: the chickens are difficult to rear from their pugnacity of disposition. The game cock has long been a bird both of cruel and curious sport in this as well as other countries; but the taste for these amusements, like that for others suited to times of comparative leisure and ignorance, is now happily on the decline in Britain.



short, five claws on each foot; eggs large, and lays abundantly; colour of the flesh inclining to yellowish or ivory. Both hens and cocks often made into capons.

7443. *The Dorking cock and hen (fig. 930.)*, so called from the town in Surrey of that name, is the largest variety; shape handsome; body long and capacious; legs

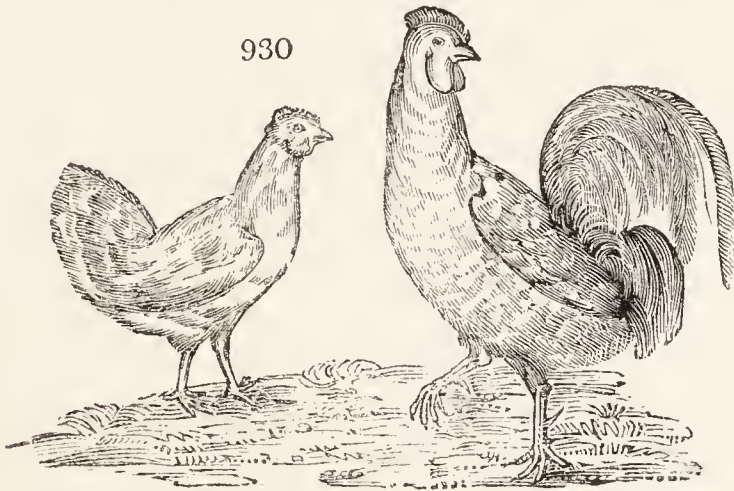
7444. *The Poland cock and hen (fig. 931.)*

a) were originally imported from Holland. The colour shining black, with white tops on the head of both cock and hen; head flat, surmounted by a fleshy protuberance, out of which spring the crown feathers, or top, white or black, with the fleshy king David's crown (the *celestial* in heraldry), consisting of four or five spikes; their form plump and deep; legs short, feet with five claws; lay abundantly; are less inclined to set than any other breed; they fatten quickly, and are more juicy and rich than the Dorking. On the whole, this is one of the most useful varieties. There is an ornamental subvariety known as the golden Poland (*b*), with yellow and black plumage.

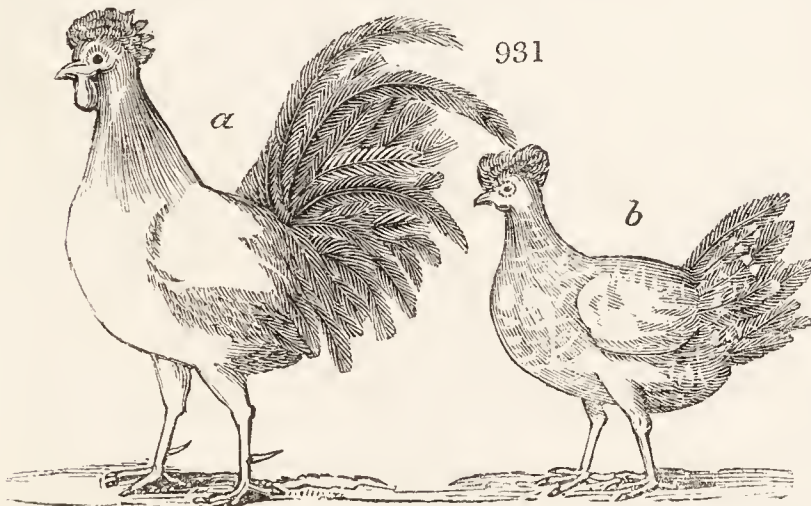
7445. *The every-day cock and hen* is a said to be everlasting layers. Their tops are large, and should be periodically clipped near the eyes; otherwise, according to Mowbray (*Treatise on Domestic Fowls*, 24. and 115.), they will grow into the eyes of the fowls and render them very subject to alarm.

7446. *The bantam cock and hen (fig. 932)* is a small Indian breed, valued chiefly for its grotesque figure and delicate flesh. Mowbray mentions a subvariety, extremely small, and as smooth-legged as a game fowl. From their size and delicacy they are very convenient, as they may always be used as substitutes for chickens, when small ones are not otherwise to be had. They are also particularly useful for sitting upon the eggs of partridges and pheasants, being good of which the more common is re-

930

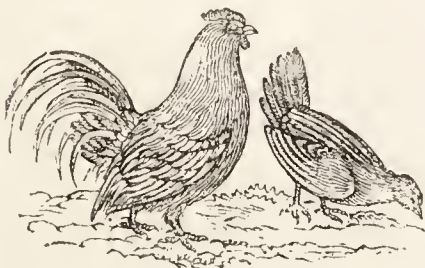


subvariety of the above, of Dutch origin; they are of smaller size, and



nurses as well as good layers. There are two varieties of this breed, markable for having the legs and feet furnished with feathers. The other, and more scarce, variety is even smaller; and is most elegantly formed, as well as most delicately limbed. There is a society of fanciers of this breed, who rear them for prizes, among which Sir John Sebright stands pre-eminent.

932

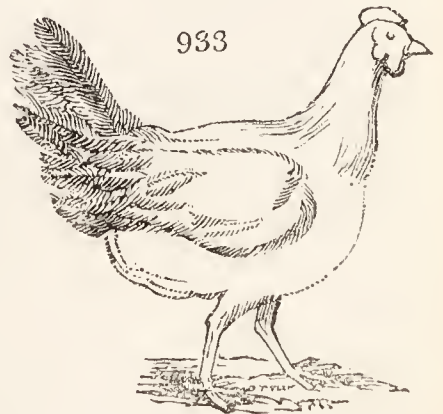


7447. *The Chittagong or Malay hen (fig. 933.)* is an Indian breed, and the largest variety of the species. They are in colour striated, yellow, and dark brown; long necked, serpent-headed, and high upon the leg; their flesh dark, coarse, and chiefly adapted to soup. They are good layers; and being well fed produce large, substantial, and nutritive eggs: but these birds are too long-legged to be steady sitters.

7448. *The Shack-bag, or Duke of Leeds' breed*, was formerly in great repute, but is now nearly lost. It is sometimes to be met with at Wokingham (Oakingham), in Berkshire, and is so large, and the flesh so white, firm, and fine, as to afford a convenient substitute for the turkey.

7449. *The improved Spanish cock and hen* is a cross between the Dorking and Spanish breed, also to be found in and around Wokingham. It is a large bird with black plumage, white and delicate flesh, the largest eggs of any British variety, and well adapted for capons.

933



7450. *Breeding.* The common variety is easily procurable; but the others must either be procured from those parts of the country where they are usually bred, or from the poulterers and bird fanciers in large towns, and especially in London. It should be a general rule to breed from young stock; a two-year-old cock, or stag, and pullets in their second year. Pullets in their first year, if early birds, will, indeed, probably lay as many eggs as ever after; but the eggs are small, and such young hens are unsteady sitters. Hens are in their prime at three years of age, and decline after five, whence, generally, it is not advantageous to keep them beyond that period, with the exception of those of capital qualifications. Hens with a large comb, or which crow like the cock, are generally deemed inferior; but I have had hens with large rose combs, and also crows, which were upon an equality with the rest of the stock. Yellow-legged fowls are often of a tender constitution, and always inferior in the quality of their flesh, which is of a loose flabby texture, and ordinary flavour.

7451. *The health of fowls* is observable in the fresh and florid colour of the comb, and the brightness and dryness of the eyes; the nostrils being free from any discharge, and the healthy gloss of the plumage. The most useful cock is generally a bold, active, and savage bird, sometimes cruel and destructive in his fits of passion, if not well watched, to his hens, and even to his offspring. Hens above the common size of their respective varieties are by no means preferable either as layers or setters. The indications of old age are paleness of the comb and gills, dulness of colour, and a sort of downy stiffness in the feathers, and length and size of talons, the scales upon the legs becoming large and prominent.

7452. *The number of hens to one cock* should be from four to six, the latter being the extreme number, with a view of making the utmost advantage. Ten and even twelve hens have been formerly allowed to one cock, but the produce of eggs and chickens under such an arrangement will seldom equal that to be obtained from the smaller number of hens. Every one is aware that the spring is the best season to commence breeding with poultry, and in truth it scarcely matters how early, presupposing the best food, accommodation, and attendance, under which hens may be suffered to sit in January.

7453. *The conduct of the cock towards his hens* is generally of the kindest description, and sometimes, as in the Polish breed, so remarkably so, as to be quite incredible to those who have not witnessed it. It is not an uncommon occurrence, however, for the cock to take an antipathy to some individual hen; when it continues for any length of time it is best to remove her, and supply her place by another, taking care that the stranger be not worried by the hens. Spare coops or houses will be found useful on such occasions.

7454. *The change of a cock*, from death or accident, is always attended with interruption and delay, as it may be some considerable time before the hens will associate kindly with their new partner; and further, a new cock may prove dull and inactive from the change, however good in nature. This frequently happens with cocks of the superior breeds, purchased from the London dealers, in whose coops they have been kept in such a high state of temperature, that they are unable to endure the open air of the country, unless in the summer season. Such being removed in autumn, winter, or early in spring, if immediately turned abroad with hens, are liable to become aguish, torpid, and totally useless; perhaps, in the end, turning rousy or glandered. The only method of safety in this case is to keep such a cock in the house, upon the best and most nourishing food, turning the hens to him several times in the day, and permitting him to be abroad an hour or so, the weather being fine, until, in a few weeks, he shall be accustomed to the air.

7455. *In making the nests*, short and soft straw is to be preferred; because, the straw being long, the hen, on leaving her nest, will be liable to draw it out with her claws, and with it the eggs. The hen, it is ascertained, will breed and lay eggs without the company of a cock; of course, such eggs are barren.

7456. *Eggs for setting* should never exceed the age of a month, the newer to be preferred, as nearly of a size as possible, and of the full middle size; void of the circular flaw, which indicates the double yolk, generally unproductive, nor should there be any roughness or cracks in the shells. The number of eggs, according to the size of the hen, from nine to fifteen, an odd number being preferable, on the supposition of their lying more close. The eggs to be marked with a pen and ink, and examined when the hen leaves her nest, in order to detect any fresh ones which she may have laid, and which should be immediately taken from her, as they, if at all, would be hatched too late for the brood. It is taken for granted the box and nest have been made perfectly clean for the reception of the hen, and that a new nest has not been sluggishly or sluttishly thrown upon an old one, from the filth of which vermin are propagated, to the great annoyance of the hen, and prevention of her steady sitting. Eggs broken in the nest should be cleared away the instant of discovery, and the remaining washed with warm water, and quickly replaced, lest they adhere to the hen, and be drawn out of the nest; if necessary, the hen's feathers may also be washed, but always with warm water.

7457. *With respect to the capriciousness of some hens*, in the article of sitting, it is a risk which must be left to the judgment of the attendant, who has to determine whether the hen which appears desirous of sitting may be safely trusted with eggs. Leaving a number of eggs in the nest is an enticement. Very frequently a hen will cluck, and appear hot for incubation, yet after sitting over her eggs a sufficient number of hours to addle them, will then desert them; and, probably, in the course of a few days will be taken with another fit of incubation. Much useless cruelty is too often exercised to prevent the hen from sitting, when eggs, rather than chickens, are in request. A late author recommends to thrust a feather through the hen's nostrils, in order to prevent her from sitting; and to give her half a glass of gin, then swing her round until seemingly dead, and confine her in a pot during a day or two, leaving her only a small breathing hole, to force her to sit! It is full time that those and a hundred other such utterly useless and barbarous follies of former days, practised upon various animals, should be dismissed with the contempt they merit. The pamphlet alluded to is the *Epicure*, by Thomas Young, a publication replete with good things on the interesting subjects of eating, wines, spirits, beer, cider, &c. It is written with *haut gout*. (Mowbray.)

7458. *Moulting.* Every succeeding year after the third, the hen continues to moult later in the season, and laying fewer or no eggs during the moulting period, which is sometimes protracted to two or three months. It should seem that old hens are seldom to be depended upon for eggs in the winter, such being scarcely full of feather until Christmas; and then, probably, may not begin to lay till April, producing at last not more than twenty or thirty eggs. In general, it is most profitable to dispose of hens whilst they are yet eatable or saleable for that purpose, which is in the spring of the third year. Nor do delicate white hens lay so many eggs in the cold season as the more hardy-coloured varieties, requiring warmth and shelter, particularly by night. Moulting, or the casting and renewal of feathers, lasts with its effects from one to three months, according to the age and strength of the bird. Whilst under this natural course, poultry are unfit for the table, as well as for breeding. It is the same with respect to young poultry, whilst shedding their feathers in the spring. The regular moulting of full-grown fowls begins in the autumn.

7459. *In some hens the desire of incubation* is so powerful, that they will repeat it five or six times in the year; in others it is so slight, that they will probably not sit more than once or twice in the season. A skilful breeder will take advantage of these qualities, and provide abundance of eggs from the one variety, and of chickens by means of the other. Hens, when sitting, drink more than usual: and it is an advisable practice to place water constantly before them when in this state, and food (say corn) at least twice a day. The time of incubation is twenty-one days.

7460. *Hatching.* The chicken, hitherto rolled up like a ball, with its bill under the right wing, like a bird asleep, begins generally on the morning of the twenty-second day to break its way through the shell; neither the hen, nor can the art of man, with safety render them aid in this very interesting and wonderful operation. The parental affection of the hen, as Mowbray and Parmentier have observed, is always

intensely increased, when she first hears the voice of the chicks through the shells, and the strokes of their little bills against them. The signs of a need of assistance, the former author observes, are, the egg being partly pecked, and the efforts of the chicken discontinued for five or six hours. The shell may then be broken cautiously, and the body of the chicken carefully separated from the viscous fluid which lines it. Réaumur gives it as his opinion, that no aid ought to be given to any chickens but those which have been near twenty-four hours empic'ed without getting forward in their work.

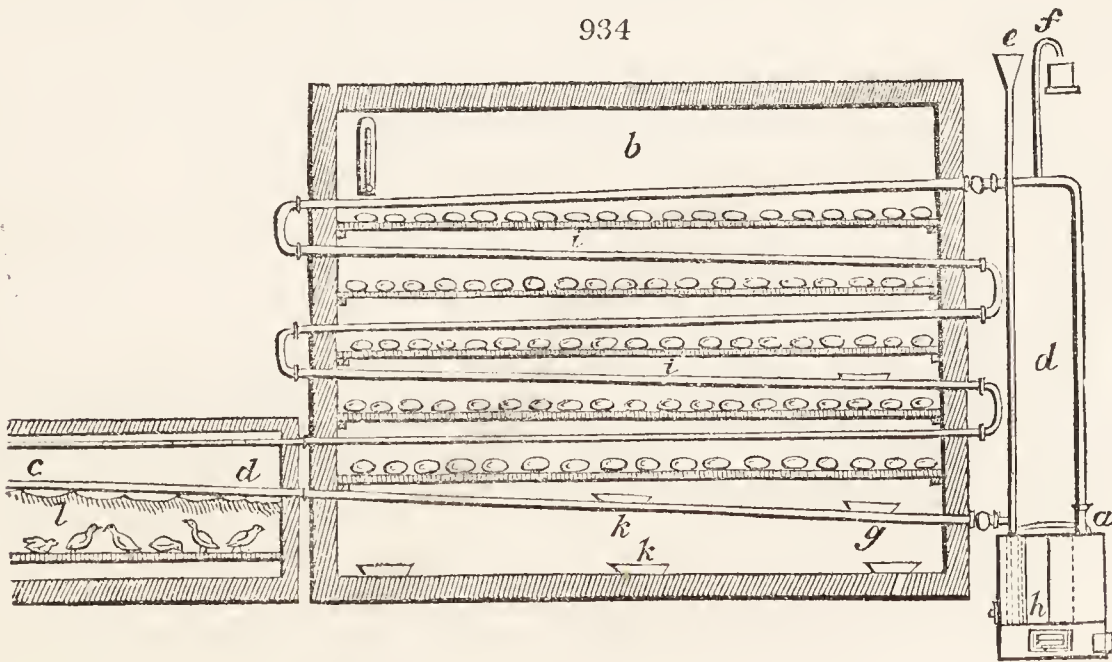
7461. *The chickens first hatched* should be taken from the hen, lest she be tempted to leave her task unfinished. Those removed may be secured in a basket of wool or soft hay, and kept in a moderate heat, if the weather be cold, near the fire. They will require no food for many hours, even four-and-twenty, should it be necessary to keep them so long from the hen. The whole brood being hatched, the hen is to be placed under a coop abroad, upon a dry spot, and, if possible, not within reach of another hen, since the chickens will mix, and the hens are apt to maim or destroy those which do not belong to them. Nor should they be placed near numbers of young fowls, which are likely to crush young chicks under their feet, being always eager for the chickens' meat. The first food should be split grits, afterwards tail wheat; all watery food, soaked bread, or potatoes, is improper. Eggs boiled hard, or curd chopped small, are much approved as first food. Their water should be pure and often renewed; and there are convenient pans made, in such forms that the chickens may drink without getting into the water, which often, by wetting their feet and feathers, numbs and injures them. A bason whelmed in the middle of a pan of water will answer the end, the water running round it generally; and, independently of situation, and the disposition of the hen, there is no necessity for cooping the brood beyond two or three days; but they may be confined as occasion requires, or suffered to range, as they are much benefited by the scratching and foraging of the hen. They must not be let out too early in the morning, or whilst the dew remains upon the ground, far less be suffered to range over the wet grass, one common and fatal cause of disease. Another caution is of the utmost consequence, to guard them watchfully against sudden unfavourable changes of the weather, more particularly if attended with rain. Nearly all the disorders of gallinaceous fowls arise from cold moisture.

7462. *For the period of the chickens quitting the hen*, there is no general rule: the most certain is, when the hen begins to roost, leaving them; if sufficiently forward, they will follow her; if otherwise, they should be secured in a proper place, the time having arrived when they are to associate with the young poultry, as nearly of their own age and size as possible, since the larger are apt to overrun and drive from their food the younger brood.

7463. *Hatching by artificial heat* is an Egyptian practice, mentioned by Diodorus and Aristotle, and was brought into notice about the middle of the eighteenth century, by Réaumur in his "*Art de faire éclore, &c. des Oiseaux domestiques.*" The requisite degree of heat is 90 degrees, which is supplied by fire, steam, hot water, or fermentible substances; after hatching, the birds are placed in a cage, in which is placed a lamb-skin suspended from the roof of a box, and enclosed by a curtain of green baize; or, according to Parmentier, they may be placed under a capon, which, after being prepared for receiving pleasure from feeling the chickens under its belly, by depriving it of the greater part of the feathers and excoriation, is to be confined with them in the same coop, and after being fed together for a day or two, it is said the capon will become an excellent nursing mother. Excepting as matter of curiosity, however, it is not at present worth while either to hatch or rear chickens artificially in this country. Whether Réaumur's mode of hatching be adopted, or Mrs. D'Oyley's of depriving hens of their chickens as soon as hatched, and thus causing one hen to hatch five or six broods in succession, the human attention required, and the risk of failure are so great, that the surest modes, under all the present circumstances, are such as are natural. Where it is tried for experiment or curiosity, the heat of tan or dung is more likely to prove steady than that from smoke, air, or steam, probably even than that of hot water, successfully tried, however, and, we believe, still practised in the neighbourhood of Paris. An enclosure in the middle of a broad vinery or hothouse might serve at once to hatch and rear early chickens; and such a mode of rearing, at least in the winter season, certainly deserves the attention of those who are curious in having this luxury in February and March. In 1822 or 1823 some interesting experiments were exhibited by Mr. Barlow at the Egyptian Hall, London, relative to an improved method which he had invented, of hatching eggs by artificial heat. The method, and the machine necessary to practise it, seem to have come very little into use.

7464. *The incubation of chickens by hot water* is the invention of M. Bonnemain, physician, of Paris, in 1777; and still alive when we were in that capital in 1828. Chickens hatched in this way at St. Germain's, under M. B.'s direction, it is said, supplied the table of Louis XIV. The boiler of the apparatus is called a *calorifère*, (*calor*, heat, and *fero*, to bear,) and consists of a small boiler (fig. 934. a), a box or

934



building (b) for hatching the eggs, a cage or coop (c) for rearing the chickens, tubes (d) for circulating the hot water, a supply tube and funnel (e), and a safety tube (f). Supposing the water heated in the boiler, it will rise by its specific levity through the tube (a, d), move progressively through all the tubes, and return again to the boiler by the tube (g), which is inserted in the lid like the other, but passes down to its lower part (h). This circulatory movement, once commenced, continues so long as the water is heated in the boiler, because the temperature is never equal throughout all parts of the apparatus. We may readily conceive that a perfect equality of temperature can never exist, on account of the continual loss of heat, which escapes from the exteriors of all the tubes. Meanwhile, the temperature of the air en-

closed in the box differs but little from that of the numerous tubes which traverse it; and as the bends of the tubes on the outside of the box afford but little surface to be cooled by the surrounding air, so the force of the circulation, which is always in the ratio of the difference between the temperature of the waters passing out of the calorifère and re-entering it, does not become greatly diminished, even after having expended a large portion of its heat on the outside of the box, in maintaining a gentle heat in the cage (c) adjoining to it. We see, therefore, that the more the water is cooled which passes through the last circumvolutions of the tubes, the more active is the circulation in all parts; and, consequently, the more equal is the temperature of all the tubes which heat the box, and of the air within it: indeed, to prevent the loss of heat as much as possible, the boiler, and all those parts of the tubes which are placed on the exterior of the box, are enveloped in lists of woollen cloth. M. Bonnemain having thus applied these principles with so much skill, is always enabled to maintain in these boxes an equal temperature, varying scarcely so much as half a degree of Réaumur's thermometer; but, as if it was not sufficient to have thus far resolved the problem, he contrived that this degree of temperature in all parts of the stove should be maintained at that point which was found most favourable for promoting incubation. It was by means of an apparatus for regulating the fire that he attained this desirable object. The action of this regulator is founded on the unequal dilatation of different metals by heat. A movement is communicated near to the axis of a balanced lever, which lever transmits it by an iron wire to a register in the ash-pit door of the furnace. Combustion is by these means abated or increased. The details of this piece of machinery are fully described and delineated in *Gill's Technological Register* (Feb. 1828, p. 70.).

7465. *When we would hatch chickens by hot water*, we light the fire and raise the temperature till we obtain that degree of heat in the box which is fitted for incubation; we then place the eggs near to each other, upon the shelves, with borders to them (*i, i*), which are fixed under each row of tubes. It is convenient not to cover, on the first day, more than a twentieth part of the superficies of the shelves, and to add every day, for twenty days, an equal quantity of eggs; so that, on the twenty-first day, the quantity of eggs first placed will be, for the greatest part, hatched: so that we may obtain every day nearly the same number of chickens; but which may, nevertheless, be occasionally regulated by the particular season of the year.

7466. *During the first days of incubation*, whether natural or artificial, the small portion of water contained within the substance of the egg evaporates through the pores in its shell: this is replaced by a small quantity of air, which is necessary to support the respiration of the chick; but as the atmospheric air which surrounds the eggs in the box at that degree of temperature is either completely dry, or but little humid, so the chick would greatly suffer, or finally perish, from this kind of desiccation. The aqueous vapour which exhales from the breathing of the old fowls while hatching, in some degree prevents this ill effect; but, nevertheless, in dry seasons, the vapour is hardly sufficient: and thus, in order that the eggs may be better hatched in the dry seasons, the hens cover them with the earth of the floor of the granary. In artificial incubation, to keep the air in the stove constantly humid, they place in it flat vessels, such as plates (*k, k*), filled with water. When the chickens are hatched, they are removed from the stove, and carried to the cage (*c*), where they are fed with millet, and nestle under a sheep's skin with wool on it (*l*), suspended over them. They also separate, by means of partitions in the cage, the chickens as they are hatched each day, in order to modify their nourishment agreeably to their age. Artificial incubation is exceedingly useful in furnishing young fowls at those seasons when the hens will not sit, and, in some situations, to produce, or, as we may say indeed, to manufacture a great number of fowls in a small space. (*Gill's Technological Repository*, No. viii. p. 73. as quoted in *Gard. Mag.* vol. iv. p. 307.)

7467. *The products of the cock and hen* are eggs, feathers, and the carcass.

7468. *Eggs* become desiccated, and, in consequence, lose great part of their substance and nutritive quality, by keeping; and every body knows the value of a fresh-laid egg. They will retain their moisture and goodness, however, three or four months, or more, if the pores of the shell be closed and rendered impervious to the air, by some unctuous application. We generally anoint them with mutton suet melted, and set them on end, wedged close together, in bran, *stratum super stratum*, the containing box being closely covered. Laid upon the side, the yolk will adhere to the shell. They thus come into use, at the end of a considerable period of time, in a state almost equal to new-laid eggs, for consumption; but ought not to be trusted for incubation, excepting in the case of the imported eggs of rare birds.

7469. *The largest eggs* will weigh two ounces and a half, those of the Chittagong hen perhaps three ounces. To promote fecundity and great laying in the hen, nothing more is necessary than the best corn and fair water; malted or sprouted barley has occasionally a good effect, whilst the hens are kept on solid corn; but if continued too long they are apt to scour. Cordial horse-ball is good to promote laying in the cold season, and also toast and ale, as every henwife well knows. It must be noted, that nothing is more necessary towards success in the particular of obtaining plenty of eggs, than a good attendance of cocks, especially in the cold season; and it is also especially to be observed, that a cock whilst moulting is generally useless. Buffon says, a hen well fed and attended will produce upwards of one hundred and fifty eggs in a year, besides two broods of chickens. Mowbray observed, that a hen generally cackled three or four days previously to laying; and that some half-bred game hens began to lay as soon as their chickens were three weeks old; the consequence of high keep and good attendance of the cocks.

7470. *Feathers or down* intended for use should be plucked as soon as possible after the bird is dead, and before it is cold, otherwise they are defective in that elasticity which is their most valuable property, and are liable to decay. The bird should, besides, be in good health, and not moulting, for the feathers to be in perfection; and being plucked, and a sufficient number collected, the sooner they are dried upon the oven the better, since they are else apt to heat and stick together.

7471. *The feathers of birds* are applied to various purposes of utility and ornament. "The plumassier collects and prepares the delicate feathers of birds, and gives them the most brilliant colours, in order to vend them to the embroiderer, and the manufacturer of artificial flowers, who introduces them into their embroideries, and forms them into bouquets and garlands, to add to the elegancies of dress and furniture, according to the tastes indicated by fashion. The plumassier only employs the feathers of the ostrich, the heron, the peacock, the swan, the goose, and the cock; these he prepares and disposes in a fit manner to adorn our hats, robes, &c.; he also makes *aigrettes*, and an infinity of other objects. The workman who forms the feathers for these uses is termed a *plumassier*. All the kinds of feathers which possess great brilliancy, extent, and fineness, are also employed in a great variety of circumstances, although those are preferred which we have above mentioned." (*Gill's Tech. Rep.* vol. vi. See p. 248.)

7472. *Where hens are kept more than a year* they are sometimes plucked towards the end of the spring season for the sake of their feathers. This operation, where it takes place, ought to be performed in the most tender and careful manner, and the birds housed afterwards for a time sufficient to enable them to endure the air: but the practice is cruel, and we trust it is not likely to come into general use.

7473. *Feeding and fattening the carcass*. Fowls will become fat on the common run of the farm-yard, where they thrive upon the offals of the stable, and other refuse, with perhaps some small regular daily feeds; but at threshing time they become particularly fat, and are thence styled barn-door fowls, probably the most delicate and high flavoured of all others, both from their full allowance of the finest corn, and the constant health in which they are kept, by living in a natural state, and having the full enjoyment of air and exercise. They are also confined during a certain number of weeks, in coops, those fowls which are soonest ready being drawn as wanted. It is a common practice with some housewives, to coop their barn-door fowls for a week or two, under the notion of improving them for the table, and increasing their fat; a practice which, however, seldom succeeds, since the fowls generally pine for their loss of liberty,

and slighting their food, lose instead of gaining additional flesh. Such a period, in fact, is too short for them to become accustomed to confinement.

7474. *Feeding-houses* should be warm and airy, with earth floors well raised, and capacious enough to accommodate twenty or thirty fowls; the floor slightly littered down, and the litter often changed. Sandy gravel and a little lime rubbish should be placed in different places, and often changed. A sufficient number of troughs, for both water and food, should be placed around, that the stock may feed with as little interruption as possible from each other, and perches in the same proportion should be furnished for those birds which are inclined to perch, which few of them will desire after they have begun to fatten, but which helps to keep them easy and contented until that period. In this mode fowls may be fattened to the highest pitch, and yet preserved in a healthy state, their flesh being equal in quality to that of the barn-door fowl. To suffer fattening fowls to perch is contrary to the general practice, since it is supposed to bend and deform the breast-bone; but as soon as they become heavy and indolent from feeding, they will rather incline to rest in the straw; and the liberty of perching in the commencement of their cooping has a tendency to accelerate that period, when they are more inclined to rest on the floor. Fowls, moreover, of considerable growth will have many of them become already crooked breasted from perching whilst at large, although much depends upon form in this case, since we find aged cocks and hens of the best shape which have perched all their lives with the breast bone perfectly straight.

7475. *The privation of light*, by inclining fowls to a constant state of repose, excepting when moved by the appetite for food, promotes and accelerates obesity; but a state of obesity obtained in this way cannot be a state of health, nor can the flesh of animals so fed equal in flavour, nutriment, and salubrity, that of the same species fed in a more natural way. Economy and market interest may perhaps be best answered by the plan of darkness and close confinement; but a feeder for his own table, of delicate taste, and ambitious of furnishing his board with the choicest and most salubrious viands, will declare for the natural mode of feeding; and in that view, a feeding-yard, gravelled and turfed, the room being open all day, for the fowls to retire at pleasure, will have a decided preference, as the nearest approach to the barn-door system.

7476. *Insects and animal food* form a part of the natural diet of poultry, are medicinal to them in a weakly state, and the want of such food may sometimes impede their thriving.

7477. *For fattening the younger chickens*, the above feeding-room and yard is well calculated. These may be put up as soon as the hen shall have quitted her charge, and before they have run off the sucking flesh; for generally, when well kept and in health, they will be in fine condition and full of flesh at that period, which flesh is afterwards expended in the exercise of foraging for food, and in the increase of stature, and it may be a work of some time afterwards to recover it, more especially in young cocks, and all those which stand high upon the leg. In fact, all those which appear to have long legs should be fattened from the hen, to make the best of them; it being extremely difficult, and often impossible, to fatten long-legged fowls in coops, which, however, are brought to a good weight at the barn-door.

7478. *In the choice of full-sized fowls for feeding*, the short-legged and early hatched always deserve a preference. The green linnet is an excellent model of form for the domestic fowl, and the true Dorking breed approaches the nearest to such model. Of course the smaller breeds and the game are the most delicate and soonest ripe. The London chicken butchers as they are termed, or poulterers, are said to be of all others the most dexterous feeders, putting up a coop of fowls and making them thoroughly fat within the space of a fortnight; using so much grease, and that perhaps not of the most delicate kind, in the food. In the common way this business is often badly managed, fowls being huddled together in a small coop, tearing each other to pieces, instead of enjoying that repose which alone can ensure the wished-for object; irregularly fed and cleaned, until they are so stench'd and poisoned in their own excrement, that their flesh actually smells and tastes of it when smoking upon the table. Where a steady and regular profit is required from poultry, the best method, whether for domestic use or sale, is constant high keep from the beginning; whence they will not only be always ready for the table, with very little extra attention, but their flesh will be superior in juiciness and rich flavour to those which are fattened from a low or emaciated state. Fed in this mode, the spring pullets are particularly fine, and at the same time most nourishing and restorative food. The pullets which have been hatched in March, if high fed from the nest, will lay plentifully through the following autumn; and not being intended for breeding stock, the advantage of their eggs may be taken, and themselves disposed of thoroughly fat for the table in February, about which period their laying will be finished. Instead of giving ordinary and tail corn to fattening and breeding poultry, it will be found most advantageous to allow the heaviest and best, putting the confined fowls upon a level with those fed at the barn-door, where they have their share of the weightiest and finest corn. This high feeding shows itself not only in the size and flesh of the fowls, but in the size, weight, and substantial goodness of their eggs, which in those valuable particulars will prove far superior to the eggs of fowls fed upon ordinary corn or washy potatoes; two eggs of the former going further in domestic use than three of the latter. The water also given to fattening fowls should be often renewed, fresh and clean; indeed, those which have been well kept will turn with disgust from ordinary food and foul water.

7479. *Barley and wheat are the great dependence for chicken poultry*; oats will do for full-grown hens and cocks, but are not so good as barley; both, when they have their fill of corn, will eat occasionally cabbage or beet leaves. Steamed potatoes and oatmeal mixed together make an excellent mess, but must not be given in great quantities, otherwise it renders the flesh soft and flabby.

7480. *Cramming*. Barley and wheat meal are generally the basis or chief ingredient in all fattening mixtures for chickens and fowls; but in Sussex ground oats are used, and there oats are in higher repute for fattening than elsewhere, many large hogs being fattened with them. In the report of that county, the Rev. Arthur Young says, "North Chappel and Kinsford are famous for their poultry: they are fattened there to a size and perfection unknown elsewhere. The food given them is ground oats made into gruel, mixed with hog's grease, sugar, pot-liquor, and milk; or ground oats, treacle, and suet, sheep's plucks, &c. The fowls are kept very warm, and crammed morning and night. The pot-liquor is mixed with a few handfuls of oatmeal and boiled, with which the meal is kneaded into crams or rolls of a proper size. The fowls are put into the coop two or three days before they are crammed, which is continued for a fortnight; and they are then sold to the higglers. These fowls, full grown, weigh seven pounds each, the average weight five pounds; but there are instances of individuals double the weight. They were sold at the time of the survey (1809) at four to five shillings each. Turner, of North Chappel, a tenant of Lord Egremont, crams two hundred fowls per annum. Great art and attention is requisite to cut the capons, and numbers are destroyed in the operation."

7481. *Oakingham in Berks is particularly famous for fatted fowls*, by which many persons in that town and vicinity gain a livelihood. The fowls are sold to the London dealers, and the sum of 150*l.* has been returned in one market-day by this traffic. Twenty dozen of these fowls were purchased for one gala at Windsor, after the rate of half a guinea the couple. At some seasons, fifteen shillings have been paid for a couple. Fowls constitute the principal commerce of the town. Romford, in Essex, is also a great market for poultry, but generally of the store or barn-door kind, and not artificially fed.

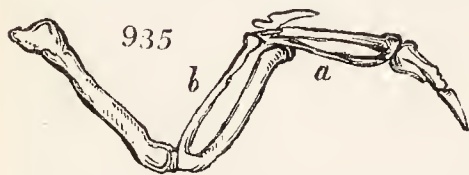
7482. *The Oakingham method of feeding* is to confine the fowls in a dark place, and cram them with paste made of barley-meal, mutton-suet, treacle, or coarse sugar, and milk; and they are found completely ripe in a fortnight. If kept longer, the fever that is induced by this continued state of repletion, renders them red and unsaleable, and frequently kills them. Geese are likewise fed in the same neighbourhood, in great numbers, and sold about midsummer to itinerant dealers; the price at the time the survey was made (1808), two shillings to two and three-pence each. It appears utterly contrary to reason, that fowls fed upon such greasy and impure mixtures can possibly produce flesh or fat so firm, delicate, high flavoured,

or nourishing, as those fattened upon more simple and substantial food; as, for example, meal and milk, without the addition of either treacle or sugar. With respect to grease of any kind, its chief effect must be to render the flesh loose and of indelicate flavour. Nor is any advantage gained, excluding the commercial one.

7483. *The methods of crumming by confining in a box* the size of the body of the fowl, and allowing its head and vent to project for intromission and ejection; of blinding the bird for this purpose; or of nailing it to the board; and also the mode of forcing down liquid food by a particular kind of pump, worked by the foot of the feeder; all these and other cruel practices we wish we could abolish in practice, and obliterate from the printed page.

7484. *Castration* is performed on cocks and hens only in some districts, and chiefly in Berkshire and Sussex. The usual time is when they have left the hen, or when the cocks begin to crow, but the earlier the better. It is a barbarous practice and better omitted. Capons are shunned both by hens and cocks, which, it is said, will not roost on the same perch with them. The Chinese mode of making capons is fully described and illustrated with cuts in the *Farmer's Magazine*, vol. vi. p. 46.

7485. *Pinioning of fowls* is often practised to restrain them from roosting too high, or from flying over fences, &c.; and is much more convenient than the cutting their wing feathers only. But in the ordinary methods of merely excising the pinion, it is frequently fatal; and almost always so to full-grown birds or fowls, by their bleeding to death. To prevent this in the long-winged tribes, as ducks, geese, &c., pass a

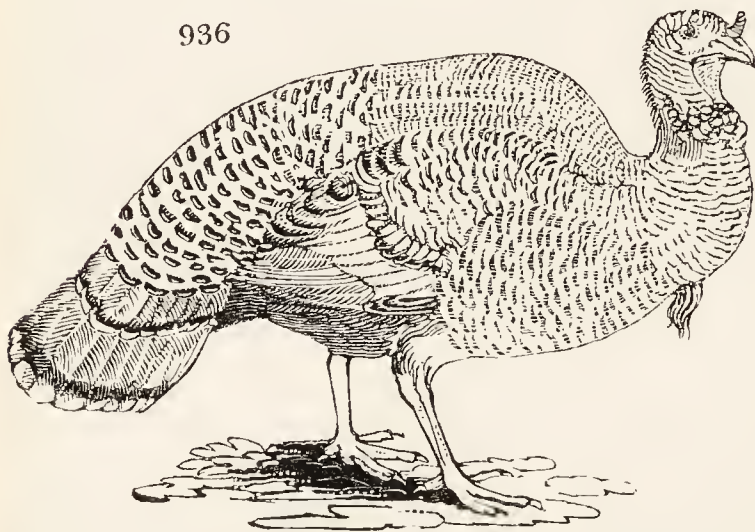


threaded needle through their wing, close by the inside of the smaller bone (*fig. 935. a*), and making a ligature with the thread across the larger bone, and returning it on the outside of all, the principal blood-vessels are secured, which could not be accomplished by a ligature confined to the surface only. After the blood-vessels have been thus secured, cut off the portion of wing beyond the ligature with scissors or shears. In the Gallinæ or short-winged tribes, as cocks, hens, &c., the operation is rendered safer by being performed on the beginning of the next joint (*b*),

making the ligature embrace all the vessels between these two bones by passing it twice through, and securing each bone individually, and passing the ligature around the whole of that part of the wing generally. In this way also birds which have been accidentally winged in shooting may be preserved.

7486. *The turkey (Melægris Gallipavo L., fig. 936.)* is a native of America, and was

936



introduced into this country from Spain soon after the discovery of the former country. The colour in the wild state is black, but domestication has produced great variety.

7487. *In a state of nature* they are said to parade in flocks of five hundred, feeding, in general, where abundance of nettles are to be found, the seed of which and of a small red acorn is their common food in the American woods. They get fat in a wild state, and are soon run down by horses and dogs. They roost on the highest trees, and since the clearing of extensive tracts in America, have become rare in many places: their antipathy to any thing of a red colour is well known. In this country they are sup-

posed to be of a tender constitution, which only applies to them when young; for when grown up they will live in the woods with occasional supplies of food, as is actually the case to a great extent in the demesne lands of the Marquis of Bute, in Bute.

7488. *The varieties* are few, and chiefly the copper and white, said to be imported from Holland, the former too tender for general culture; the black Norfolk is esteemed superior to all others.

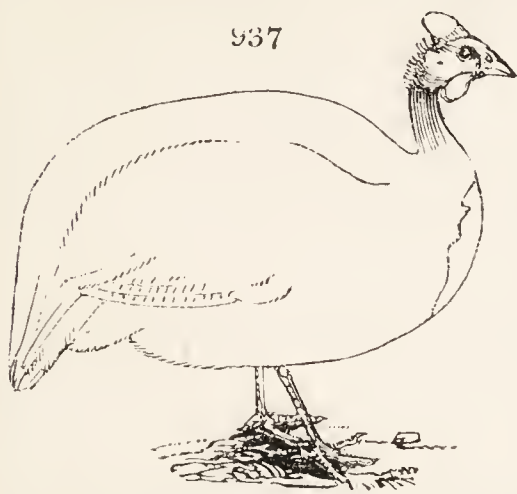
7489. *Breeding.* One turkey cock is sufficient for six hens or more, and a hen will cover according to her size from nine to fifteen eggs. The hen is apt to form her nest abroad in a hedge, or under a bush, or in some secure place; she lays from eighteen to twenty-five eggs or upwards, and her term of incubation is thirty days. She is a steady sitter, even to starvation, and therefore requires to be regularly supplied with food and water. Buffon says she is a most affectionate mother; but Mowbray observes, that from her natural heedlessness and stupidity, she is the most careless of mothers; and being a great traveller herself, will drag her brood over field, heath, or bog, never casting a regard behind her to call in her straggling chicks, nor stopping while she has one left to follow her. The turkey differs from the common hen in never scratching for her chicks, leaving them entirely to their own instinct and industry; neither will they fight for their brood, though vigilant in the discovery of birds of prey, when they will call their chickens together by a particular cry, and run with considerable speed. Hence, when not confined within certain limits, they require the attendance of a keeper.

7490. *Turkey chicks* should be withdrawn from the nest as soon as hatched, and kept very warm by wrapping them in flannel, or putting them under an artificial mother in a warm room or other warm place. Various nostrums are recommended to be given and done at this season, as a peppercorn and a tea-spoonful of milk, immersion in cold water, &c. Mowbray wisely rejected all these unnatural practices, and succeeded by giving curd and hard eggs, or curd and barley meal kneaded with milk, and renewed with clear water rather than milk, as he found the last often scoured them. A sort of vermicelli, or artificial worms, made from pulling boiled meat into strings, he found beneficial for every species of gallinaceous chicken. Two great objects are, to avoid superfluous moisture, and to maintain the utmost cleanliness, for which purposes as little slop food is given as possible. A fresh tuft of short sweet grass should be daily given as green food, but not snails or worms as scouring, and no oats; nettle seed, clover, rue, or wormwood gathered, as recommended by the elder housewives. Water is generally preferable to milk. When the weather is favourable, the hen is cooped abroad in the forenoon. During the rest of the day and night, for the first six weeks, she is kept within doors. After this the hen may be cooped a whole day externally for another fortnight, to harden the chickens; and afterwards they may be left to range within certain limits, or tended by an old man or woman, being fed at going out in the morning and returning in the evening. Their ordinary food may be that of the common cocks and hens. They will prefer roosting abroad upon high trees in the summer season, but that cannot generally be permitted with a view to their safe keeping.

7491. *Fattening.* Sudden barley, or barley and wheat-meal mixed, is the most approved food; and the general mode of management is the same as that of the common cock and hen. They are generally fed so as to come in at Christmas, but they may be fattened early or late. Sometimes though, but rarely, they are caponised. Buffon says, the wild turkey of America has been known to attain the weight of sixteen pounds; the Norfolk turkeys are said sometimes to weigh twenty and thirty pounds; but Mowbray says,

he never made any higher than fifteen pounds ready for the spit. The living and dead weight of a turkey are as 21 to 14.

7492. *Feathers.* Turkeys are sometimes plucked alive, a barbarous practice which ought to be laid aside. Parmentier proposed to multiply the breed of white turkeys in France, and to employ the feathers found on the lateral part of the thighs instead of the plumes of the ostrich.



7493. *The Guinea hen* (*Numidia Melèagris L.*, fig. 937.) is found in a wild state only in Africa, from whence it has been diffused over every part of Europe, the West Indies, and America. In a state of nature these birds associate in flocks of two or three hundred. They delight in marshy places, but always perch during the night in trees, or high situations. It is bigger than a large cock, and is active, restless, and courageous; and will even attack the turkey, though so much above its size.

7494. *The properties of the pheasant and the turkey* have been said to be united in this bird; its flesh is more like that of the pheasant than that of the common cock and hen both in colour and taste, and is reckoned a very good substitute for the former bird. It is also very prolific, and its eggs are nourishing and good. It assimilates perfectly with common fowls in its artificial habits and kinds of food; but it has this peculiarity — that the cocks and hens are so nearly alike, that it is difficult to distinguish them, and it has a peculiar gait, and cry, and chuckle.

7495. *The peacock* (*Pavo cristatus L.*) is a native of India, and found in a wild state in Java and Ceylon, where they perch on trees like the turkey in America. The age of the peacock extends to twenty years, and at three the tail of the cock is full and complete. The cock requires from three to four hens; and where the country agrees with them, they are very prolific, a great ornament to the poultry yard and lawns, and useful for the destruction of all kinds of reptiles. Unfortunately, they are not easily kept within moderate bounds, and are very destructive in gardens. They live on the same food as other domestic fowls, and prefer barley. They are in season from February till June; but though a peacock forms a very showy dish, the flesh is ill-coloured and coarse, and they are therefore kept more as birds of ornament than of use.

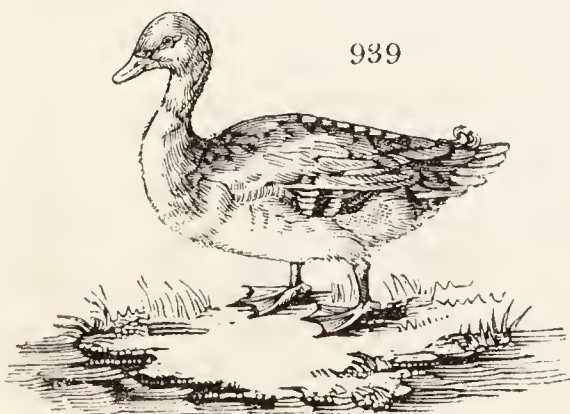


7496. *The crested curassow* (*Crax Aléctor L.* fig. 938.) is a beautiful and majestic bird, nearly the size of a turkey; it is common in some parts of tropical America, and is mentioned as being abundant in Paraguay. In those countries it is tamed, and readily associates with the other domestic poultry. Like most gallinaceous birds, it lives in flocks of about a dozen, feeds upon Indian corn, rice, and other grain during the day, and roosts on high trees at night.

Its size, disposition, and the delicacy of its flesh, all recommend our attempting to domesticate it in this country.

SECT. III. *Anserine or Aquatic Fowls.*

7497. *The order anseres* comprehends the duck, goose, swan, and buzzard. Under a regular system, Mowbray observes, it would be preferable to separate entirely the aquatic from the other poultry; the former to have their houses ranged along the banks of a piece of water, with a fence, and sufficiently capacious walks in front; access to the water by doors, to be closed at will. Should the water be of considerable extent, a small boat would be necessary, and might be also conducive to the pleasure of angling.



7498. *The duck* (*Anas Boschas L.*, fig. 939.) is a native of Britain, and found frequenting the edges and banks of lakes in most parts of Europe. The flesh of this and various other species of the duck is savory and stimulant, and said to afford preferable nourishment to that of the goose, being less gross, and more easily digested. The flesh of the wild duck, though more savoury than that of the tame, is reckoned still more easy of digestion. The ancients went even beyond our greatest modern epicures in their high esteem for the flesh of the duck; and Plutarch asserts, that Cato preserved his whole household in health by dieting them on duck's flesh.

7499. *Varieties and species.* There are the *Rhone*, the *Aylesbury*, the *canvass-backed*, and the *Muscovy*.

7500. *The Rhone duck* is originally from France, and generally of a dark-coloured plumage, large size, and supposed to improve our breed. They are of darker flesh, and more savoury, than the English duck; but somewhat coarse. Rhone

ducks have been so constantly imported for a great number of years, that they are very generally mixed with our native breed. The English duck, particularly the white variety, especially when they chance to have light-coloured flesh, are never of so

high and savoury flavour as the darker colours. Muscovy, and other foreign species of the duck, are kept rather out of curiosity than for the table.

7501. *The white Aylesbury* are a beautiful and ornamental stock, matching well in colour with the Embden geese. They are said to be early breeders.

7503. *The Muscovy duck* (*A. moschata* L.) is a native of Brazil, but domesticated in Europe. It is a curious dark-coloured bird, distinguished by its naked face, kept more out of curiosity than use; to be retained in any place, they must be reared there from the egg, otherwise they will fly away.

7504. *Breeding.* One drake is generally put to five ducks; the duck will cover from eleven to fifteen eggs, and her term of incubation is thirty days. They begin to lay in February, are very prolific, and are apt, like the Turkey, to lay abroad, and conceal their eggs, by covering them with leaves or straws. The duck generally lays by night, or early in the morning: white and light-coloured ducks produce similar eggs; and the brown and dark-coloured ducks, those of a greenish blue colour, and of the largest size. In setting ducks, it is considered safest to put light-coloured eggs under light ducks, and the contrary; as there are instances of the duck turning out with her bill those eggs which were not of her natural colour.

7505. *During incubation,* the duck requires a secret and safe place, rather than any attendance, and will, at nature's call, cover her eggs, and seek her food, and the refreshment of the waters. On hatching, there is not often a necessity for taking away any of the brood, barring accidents; and having hatched, let the duck retain her young upon the nest her own time. On moving her with her brood, prepare a coop upon the short grass, if the weather be fine, or under a shelter, if otherwise: a wide and flat dish of water, often to be renewed, standing at hand; barley, or any meal, the first food. In rainy weather particularly, it is useful to clip the tails of the ducklings, and the surrounding down beneath, since they are else apt to draggle and weaken themselves. The duck should be cooped at a distance from any other. The period of her confinement to the coop depends on the weather and the strength of the ducklings. A fortnight seems the longest time necessary; and they may be sometimes permitted to enjoy the pond at the end of a week, but not for too great a length at once, least of all in cold wet weather, which will affect, and cause them to scour, and appear rough and draggled. In such case they must be kept within a while, and have an allowance of bean or pea meal mixed with their ordinary food. The meal of buck-wheat and the former is then proper. The straw beneath the duck should be often renewed, that the brood may have a dry and comfortable bed; and the mother herself be well fed with solid corn, without an ample allowance of which ducks are not to be reared or kept in perfection, although they gather so much abroad.

7506. *Duck eggs are often hatched by hens,* when ducks are more in request than chickens; also as ducks, in unfavourable situations, are the more easy to rear, as more hardy; and the plan has no objection in a confined place, and with a small stock, without the advantage of a pond; but the hen is much distressed, as is sufficiently visible, and, in fact, injured, by the anxiety she suffers in witnessing the supposed perils of her children venturing upon the water.

7507. *Ducks are fattened,* either in confinement, with plenty of food and water, or full as well restricted to a pond, with access to as much solid food as they will eat; which last method is preferable. They fatten speedily, in this mode, mixing their hard meat with such a variety abroad as is natural to them, more particularly, if already in good case; and there is no check or impediment to thrift from pining, but every mouthful tells and weighs its due weight. A dish of mixed food is preferable to white corn, and may remain on the bank, or rather in a shed, for the ducks. Barley, in any form, should never be used to fatten ducks or geese, since it renders their flesh loose, woolly, and insipid, and deprives it of that high savory flavour of brown meat, which is its valuable distinction; in a word, rendering it chickeny, not unlike in flavour the flesh of ordinary and yellow-legged fowls. Oats, whole or bruised, are the standard fattening material for ducks and geese, to which may be added pea-meal, as it may be required. The house-wash is profitable to mix up their food under confinement; but it is obvious, whilst they have the benefit of what the pond affords, they can be in no want of loose food. Acorns in season are much affected by ducks which have a range; and they will thrive so much on that provision, that the quantity of fat will be inconvenient, both in cooking and upon the table. Ducks so fed are certainly inferior in delicacy, but the flesh eats high, and is far from disagreeable. Fed on butcher's offal, the flesh resembles wild fowl in flavour, with, however, considerable inferiority. Offal-fed duck's flesh does not emit the abominable stench which issues from offal-fed pork. When live ducks are plucked, only a small quantity of down and feathers should be taken from each wing.

7508. *Decoys for wild ducks.* Wild ducks, and other aquatic birds, are frequently taken by the device termed a decoy, which, in the low parts of Essex, and some other marshy districts, may be considered as connected with husbandry. A decoy is a canal or ditch, provincially pipe of water (*fig. 940.*), with a grassy



sloping margin (1) at its junction with a river or larger piece of water (8), to invite aquatic fowls to sit on and dress their plumage; but in other parts, covered with rushes and aquatic plants for concealment. Along the canal of the decoy are placed reed fences (2, 2'), to conceal the decoy-man and his dogs from the sight of the ducks. There is an opening in this fence (3), where the decoy-man first shows himself to the birds to force them to take the water; and having taken it, the dog drives them up the canal, the man

looking through the fence at different places (4, 5, 6) to frighten them forward. At the end of the canal is a tunnel net (7), where the birds are finally taken. In operating with this trap, as the wild duck is a very shy bird, and delights in retirement, the first step is to endeavour to make the given water a peaceful asylum, by suffering the ducks to rest on it undisturbed. The same love of concealment leads them to be partial to waters whose margins abound with underwood and aquatic plants; hence, if the given water is not already furnished with these appendages, they must be provided; for it is not retirement alone which leads them into these recesses, but a search after food also. At certain times of the day, when wild fowl are off their feed, they are equally delighted with a smooth grassy margin, to adjust and oil their plumage upon. On the close-pastured margins of large waters, frequented by wild fowl, hundreds may be seen amusing themselves in this way; and perhaps nothing draws them sooner to a water than a conveniency of this kind: hence it becomes essentially necessary to success, to provide a grassy, shelving, smooth-shaven bank (1) at the mouth of the decoy, in order to draw the fowl, not only to the water at large, but to the desired part of it. Having, by these means, allured them to the mouth of the decoy; the difficulties that remain are, those of getting them off the bank into the water, without taking wing, and of leading them up the canal to the snare which is set for them in the most easy manner.

7509. *In order to get them off the bank into the water*, a dog is necessary (the more like a fox the better), which should steal from behind the skreen of reeds, (2, 2,) which is placed by the side of the canal to hide the decoy-man as well as his dog, until the signal be given. On seeing the dog, the ducks rush into the water; where the wild fowl consider themselves as safe from the enemy which had assailed them, and of course do not take wing. Among the wild fowl, a parrel (perhaps eight or ten) of decoy-ducks should be mixed, which will probably be instrumental in bringing them, with greater confidence, to the bank. As soon as these are in the water, they make for the decoy, at the head of which they have been constantly fed, and in which they have always found an asylum from the dog. The wild ducks follow; while the dog keeps driving behind; and, by that means, takes off their attention from the trap they are entering. When, as soon as the decoy-man, who is all the while observing the operation through peep-holes in the reed skreen, sees the entire shoal under a canopy net which covers and encloses the upper part of the canal, he shows himself, when the wild fowl instantly take wing, but their wings meeting with an impervious net, instead of a natural canopy, formed of reeds and bulrushes, they fall again into the water, and, being afraid to recede, the man being close behind them, they push forward into the tail of the tunnel net, which terminates the decoy. In this way, nine dozen have been caught at a time.

7510. *The form of the pipe or canal* ought to resemble the outlet of a natural brook, or a natural inlet or creek of the principal water. The mouth ought to be spacious, and free from confinement, that the wild fowl, on their first rushing into the water, and while they have yet the power of recollection, may be induced to begin to follow the tame ducks; and for the same purpose it ought to be crooked, that its inward narrowness, and the nets, may not, in the first instance, be perceived. The lower part of a French horn is considered as the best form of the canal of a decoy that can be had. A material circumstance remains yet to be explained. It is the invariable nature of wild fowl to take wing with their heads towards the wind; and it is always imprudent to attempt to take them in a decoy, unless the wind blow down the pipe; for, while their enemy is to leeward of them, they have less scruple to go up the pipe, making sure of an escape by their wings. But, what is of still more consequence, if the wind set up the pipe when they take wing under the canopy net, some of them would probably escape (a circumstance always to be dreaded), and those which fell again into the water would fall, of course, with their heads towards the wind, and would with greater difficulty be driven into the tunnel. This point is so well known by decoy-men in general, that every decoy is, when circumstances will admit of it, furnished with three or four different canals, pointing to distinct quarters of the horizon, that no opportunity may be lost on account of the wind being in any particular point.

7511. *The goose (Anas Anser L., fig. 941.)* is a native of Britain, and most parts of the north of Europe, but less common than the duck.

941



7512. *The flesh* of the common and various species of geese is highly stimulant, strong in flavour, viscid, and of a putrescent tendency. The flesh of the tame goose is more tender than that of the wild, which tastes of fish; but either kind is only adapted for good stomachs, and powerful digestion, and should be sparingly used by the sedentary and weak, or persons subject to cutaneous diseases. The fat of the goose is reckoned peculiarly subtle, penetrating, and resolvent, and is generally carefully preserved for domestic applications. The goose attains to a great age, well authenticated instances being on record to the extent of seventy and eighty years. The best geese in England are probably to be found on the borders of Suffolk and Norfolk, and in Berkshire; but the greatest numbers are in Lincolnshire, whence they are sent in droves to London to be fed by the poulterers, some of whom fatten in the vicinity of the metropolis above five thousand in a season.

7513. *Of varieties and species* there are several, the former differing in colour, as black, white, and grey, and also in size. There is also the Spanish white goose, and large white Embden goose, the latter in most esteem. When one has seen a wild

goose, says Pennant, a description of its plumage will, to a feather, exactly correspond with any other: but in the tame kinds, no two of any species are exactly alike; different in their size, their colours, and frequently in their general form, they seem the mere creatures of art; and having been so long dependent upon man for support, they seem to assume forms entirely suited to his necessities.

7514. *There is a Chinese species (A. cygnoides)*, and an American goose (*A. canadensis*). The Chinese species is a domestic bird, but as yet little known in this country. It is longer and narrower in the body than the common goose, and stands higher on the legs. The Canadian goose is domesticated in several places, and is not considered uncommon in England. It is the most ornamental of the goose kind on water in pleasure-grounds, and is abundant in the Duke of Devonshire's park at Chiswick.

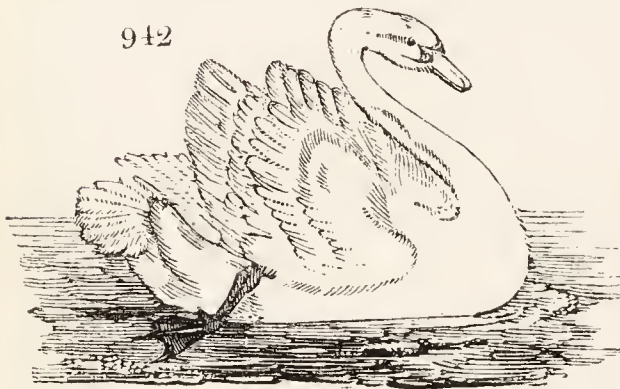
7515. *Breeding.* One gander is generally put to five geese: the goose lays from eleven to fifteen eggs; and the period of incubation is from twenty-seven to thirty days. A nest should be prepared as soon as the female begins to carry straw in her bill, and by other tokens declares her readiness to lay. This is generally in March, and sometimes two broods are produced within the season; an advantage obtainable by high feeding through the winter with sound corn, and on the commencement of the breeding season allowing them boiled barley, malt, fresh grains, and fine pollard mixed up with ale or other stimulants. A good gander sits near his geese whilst they are sitting, and vigilantly protects them. Feeding upon the nest is seldom required; and it is unnecessary to take any of the goslings from the mother as hatched; but pen the goose and her brood at once upon dry grass well sheltered, putting them out late in the morning, or not at all in severe weather, and ever taking them in early in the evening. The first food may be similar to that recommended for the duck, such as barley meal, bruised oats, or fine pollard, with some cooling green vegetables, as cabbage or beet leaves intermixed.

7516. *Rearing.* At first setting at liberty the pasturage of the goose should be limited; otherwise, if allowed to range over an extensive common, the gulls or goslings will become tired and cramped, and some of them will fall behind and be lost. Mowbray advises to destroy all the hemlock and nightshade in

their range; and he says he has known them killed by swallowing sprigs of yew. As the young become pretty well feathered, they become also too large to be brooded beneath the mother's wing, and as they will then sleep in groups by her side, they must be well supplied with straw beds, which they will convert into excellent dung. Being able, says Mowbray, to frequent the pond and range the common at large, the young geese will obtain their living, and few people, favourably situated, allow them any thing more, excepting the vegetable produce of the garden. But it has been his constant practice always to dispense a moderate quantity of any solid corn or pulse at hand to the flocks of store geese, both morning and evening, on their going out and their return, together, in the evening more especially, with such greens as chanced to be at command: cabbage, mangel-wurzel leaves, lucerne, tares, and occasionally sliced carrots. By such full keeping his geese were ever in a fleshy state, and attained a large size; the young ones were also forward and valuable breeding stock. Geese managed on the above mode will be speedily fattened green, that is, at a month or six weeks old, or after the run of the corn stubbles. Two or three weeks after the latter must be sufficient to make them thoroughly fat. A goose fattened entirely on the stubbles is to be preferred to any other; since an over-fattened goose is too much in the oil-cake and greese-tub style, to admit even the ideas of delicacy, tender firmness, or true flavour; but when needful to fatten them, the feeding-houses already recommended for hens (7474.) are most convenient. With clean and renewed beds of straw, plenty of clean water, oats, crushed or otherwise, pea or bean meal (the latter, however, coarse and ordinary food), or pollard mixed up with skim-milk, geese will fatten pleasantly and speedily.

7517. *Feathers.* Pennant, in describing the methods used in Lincolnshire in managing geese, says, "They are plucked five times in the year; first at Lady-day for the feathers and quills, and four times for the feathers only, between that and Michaelmas." He says, he saw the operation performed on goslings of six weeks old, from which the feathers of the tails were plucked, and that numbers die of the operation, if the weather immediately afterwards proves cold. This seems a cruel practice, and surely would be better left off. Lean geese furnish the greatest quantity of down and feathers, and of the best quality.

7518. *The mute or tame swan* (*Cygnus mansuetus* L., fig. 942.) has long been known



in England, but is only found wild in Russia and Siberia. It has been preserved by the severity of the laws, which have long accounted it felony to steal their eggs. Formerly they were fattened at Norwich for the city feast, and commanded a guinea each. The foot of the swan possesses nearly the same property as that of the goose; and the skin was formerly held to contain medical properties. At present swans are chiefly to be considered as ornamental in pleasure-grounds, clearing water from weeds, and

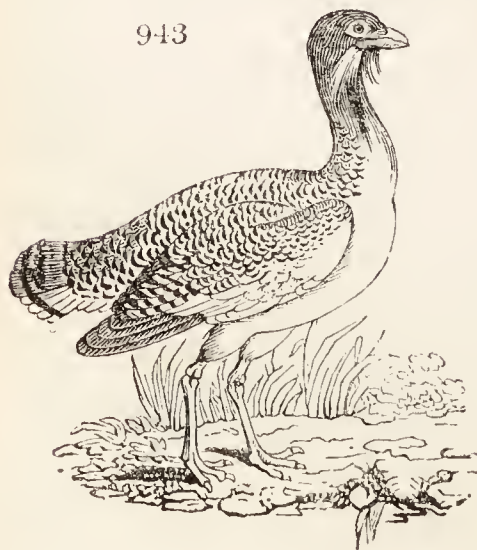
occasionally affording cygnet and some swan down feathers and quills. It is a curious circumstance that the ancients considered the swan as a high delicacy, and abstained from the flesh of the goose as impure and indigestible.

7519. *Other species* are, first, the swan goose (*A. cygnoides* L.). This is of an intermediate size between the tame swan and the common goose, with the last of which they will breed; and although they vary considerably in their colours, the species is always known by a knob on the bill. The two others which have been domesticated with us are the Canadian and the Egyptian species. The first is equally valuable with the common goose, and is very ornamental in ponds; the latter is now become very rare. The black swan, once considered a prodigy, is abundant in various parts of New Holland or Australia.

7520. *Rearing.* The swan feeds like the goose, and has the same familiarity with its keepers, kindly and eagerly receiving bread which is offered, although it is a bird of courage equal to its apparent pride, and both the cock and hen are extremely dangerous to approach during incubation, or whilst their brood is young, as they have sufficient muscular force to break a man's arm with a stroke of their wing. They both labour hard in forming a nest of water plants, long grass, and sticks, generally in some retired part or inlet of the bank of the stream or piece of water on which they are kept. The hen begins to lay in February, producing an egg every other day until she has deposited seven or eight, on which she sits six weeks, although Buffon says it is nearly two months before the young are excluded. Swans' eggs are much larger than those of a goose, white, and with a hard and sometimes tuberosus shell. The cygnets are ash-coloured when they first quit the shell, and for some months after; indeed they do not change their colour, nor begin to moult their plumage, until twelve months old, nor assume their perfect glossy whiteness until advanced in their second year.

7521. *Feathers and down.* Where the living swan is plucked, only the ripe down should be taken from each wing, and four or five feathers. This may be repeated to the extent of three times in the course of a summer.

7522. *The bustard* (*O'tis tarda* L., fig. 943.) is a native of England, the largest indige-



nous land bird in Europe, the cock generally weighing from twenty-five to twenty-seven pounds. The neck a foot long; the legs a foot and a half. It flies with some little difficulty. The head and neck of the cock ash-coloured; the back barred transversely with black and bright rust colour. The greater quill feathers black, the belly white; the tail, consisting of twenty feathers, marked with broad black bars: it has three thick toes before, and none behind.

7523. *Three species* of bustard are found in England; that called the little bustard (*O. tetrax*) differs chiefly in size, not being larger than a pheasant. Bustards were known to the ancients in Africa, and in Greece and Syria; are supposed to live about fifteen years; are gregarious, and pair in spring, laying only two eggs, nearly of the size of a goose egg, of a pale olive brown, marked with spots of a darker hue. They sit about five weeks, and the young ones run, like partridges, as soon as delivered from the shell. The cocks will fight until one is killed or falls. Their flesh has ever been held most delicious: they are

fed upon the same food as the turkey. There were formerly great flocks of bustards in this country upon the wastes and in the wolds, particularly in Norfolk, Cambridgeshire, and Dorset, and in various parts of Scotland, where they were hunted with greyhounds, and were easily taken. Buffon was mistaken in his supposition that these birds are incapable of being propagated in the domestic state, chiefly on account of the difficulty of providing them with proper food, which, in their wild state, he describes to be heath-berries and large earth-worms. Probably the haw or whitethorn berry might succeed equally well. To those who aim at variety and novelty in this line, the bustard appears peculiarly an object for propagation and increase, since the flesh is of unrivalled excellence; and it is probable this fowl will render great weight of flesh for the food consumed.

SECT. IV. *Diseases of Poultry.*

7524. *The diseases of poultry* are generally the result of improper nourishment and lodging, and the best mode of cure is by the immediate adoption of such as is proper. When that will not succeed, very little help can be derived from medical assistance; at least as that art stands at present with respect to poultry. In fact, as Mowbray observes, the far greater part of that grave and plausible account of diseases to be found in our common cattle and poultry books is a farrago of absurdity, the chief ground of which is random and ignorant guess-work.

7525. *Common fowls* are attacked by the pip, roup or catarrh, the flux, constipation, and vermin. The pip is an outside skin or scale, growing on the tip of the tongue, and is cured by tearing off the skin with the nail and rubbing the tongue with salt. Imposthume on the rump is called the roup, which term is also applied to catarrh, to which gallinaceous fowls are very subject. The imposthume is to be opened, the core thrust out, and the part washed with salt and water. Generous food and warmth is the only cure in the catarrh. The flux is to be cured with good solid food; and its opposite, constipation, with scalded bran mixed with skim-milk or pot liquor, adding a small quantity of sulphur. Vermin appear in consequence of low keep and want of cleanliness; the simplest remedy is to allow plenty of sand and ashes for the birds to roll in, and to keep their houses and roosts sweet and clean, white-washing them two or three times a year.

7526. *The roup* is a very common, and one of the most fatal, complaints to which chickens are subject. Those attacked by the disease are constantly coughing and gasping for breath. Upon dissection the wind-pipe is found almost closed up by great numbers of small red worms, which, in a certain stage of their growth, congregate into bundles large enough to stop respiration, and which, if the sufferer cannot discharge at the mouth, soon produces suffocation. Decoctions of the common yellow *Linaria vulgaris* (*Hort. Brit.* 15845.) is given as drink, which, being nauseously bitter, is supposed offensive to the worms; but perhaps some mercurial preparation, taken inwardly or applied outwardly, would answer the purpose, and, if effectual, would save thousands of chickens every year. This suggestion has never been tried.

7527. *But the catarrh* is the chief disease to which chickens and fowls are liable; and when the malady becomes confirmed with running at the nostrils, swollen eyes, &c. they are termed roup, and the disease is infectious. They should now be separated, and kept in a warm apartment and well fed. Roup hens seldom lay, and their eggs are unwholesome. In chickens this disease is called the chip: they are seen shivering, pining, and dying in corners, apparently from cold, though they are in fact in a fever. Abundant warmth and rich food are the only remedies.

7528. *Broken legs, wings, or toes* may be set and spliced, and will recover: the head being raw and the eyes blinded from fighting, wash the eyes with milk and water, and the head alternately with brandy in which is a few drops of laudanum, and with fresh butter. A cock's spurs being too long, impeding his walk and wounding his legs, they should be cut carefully with a sharp pen-knife, but not too near the quick, every three months.

7529. *Geese* are subject to the gargle, or stoppage in the head, the consequence of cold. House the patient, and give garlic beat up with fresh butter; or toast and ale, with a little confinement, will succeed equally well.

7530. *All poultry*, when young, are apt to be carried off by rats and other vermin, which must either be vigilantly guarded against or destroyed.

SECT. V. *Birds of Luxury which are or may be cultivated by Farmers.*

7531. *Birds of luxury* include the pigeon, pheasant, partridge, quail, grouse, singing birds, and birds kept as curious objects.

7532. *Of the pigeon* (*Colúmba L.*) there are three species and many varieties in cultivation. The species are the common, ring, and turtle doves, all natives of Britain. The varieties of the common pigeon enumerated by Linnæus amount to twenty-one; but those of the pigeon-fanciers to more than double that number. The ring-dove (*C. Palúmbus L.*) and the turtle-dove (*C. Túrtur*), with the greater number of the varieties, are cultivated only by a few persons, known as pigeon-fanciers; but the common pigeon of different colours is cultivated for the table.

7533. *The flesh* of the young pigeon is very savoury and stimulating, and highly valued for pies; that of the full-aged pigeon is more substantial, harder of digestion, and in a considerable degree heating. Black or dark feathered pigeons are dark fleshed and of high flavour, inclining to the game bitter of the wild pigeon. Light-coloured feathers denote light and delicate flesh. The dung of pigeons is used for tanning upper leathers for shoes; it is also an excellent manure. Pigeons are now much less cultivated than formerly, being found injurious to corn fields, and especially to fields of peas; they are, however, very ornamental. A few may be kept by most farmers, and fed with the common poultry; and some who breed domestic fowls on a large scale may, perhaps, find it worth while to add the pigeon to their number.

7534. *The variety of pigeon* most suitable for the common pigeon-house is the grey pigeon (*fig.* 944.), inclining to ash-colour and black, which generally shows fruitfulness by the redness of the eyes and feet, and by the ring of gold colour which is about the neck.

944



7535. *The varieties* of the fancy breeders are numerous, and distinguished by a variety of different names, as carriers (*fig.* 945. *a*), croppers, powters, horsemen, runts, jacobines, turbits, helmets, nuns, tumblers (*b*), barbs, petits, owls, spots, trumpeters, shakers, turners, finikins, &c. From these, when differently paired, are bred bastard pigeons; thus from the cropper or powter and the carrier is bred the powting horsemen (*c*); from the tumbler and the horsemen dragoons, &c.

7536. *The stocking of pigeon-houses is best performed in May or August, as the birds are then in the best condition. Young birds called squeakers should be chosen, as the old are apt to fly away.*

945



7537. *In breeding, the pigeon lays two white eggs, which produce young ones of different sexes. When the eggs are laid, the female sits fifteen days, not including the three days she is employed in laying, and is relieved at intervals by the male. The turns are generally pretty regular. The female usually sits from about five in the evening till nine the next morning; at which time the male supplies her place, while she is seeking refreshment abroad. Thus they sit alternately till the young are hatched. If the female does not return at the expected time, the male seeks her, and drives her to the nest; and should he in his turn be neglectful, she retaliates with equal severity. When the young ones are hatched, they only require warmth for the first three days; a task which the female takes entirely upon herself, and never leaves them except for a few minutes to take a little food. After this they are fed about ten days, with what the old ones have picked up in the fields, and kept treasured in their crops, from whence they satisfy the craving appetite of their young ones, who receive it very greedily. This way of supplying the young with food from the crop, in birds of the pigeon-kind, differs from all others. The pigeon has the largest crop of any bird, for its size; which is also quite peculiar to the kind. In two that were dissected by an eminent anatomist, it was found that, upon blowing the air into the windpipe, it distended the crop or gullet to an enormous size. Pigeons live entirely upon grain and water; these being mixed together in the crop are digested in proportion as the bird lays in its provision. Young pigeons are very ravenous, which necessitates the old ones to lay in a more plentiful supply than ordinary, and to give it a sort of half maceration in the crop, to make it fit for their tender stomachs. The numerous glands, assisted by air and the heat of the bird's body, are the necessary apparatus for secreting a sort of pap, or milky fluid (commonly called pigeon's milk); but as the food macerates, it also swells, and the crop is considerably dilated. If the crop were filled with solid substances, the bird could not contract it; but it is obvious the bird has the power to compress its crop at pleasure, and, by discharging the air, can drive the food out also, which is forced up the gullet with great ease. The young usually receive this tribute of affection from the crop three times a day. The male for the most part feeds the young female, and the old female performs the same service for the young male. While the young are weak, the old ones supply them with food macerated suitable to their tender frame; but, as they gain strength, the parents give it less preparation, and at last drive them out, when a craving appetite obliges them to shift for themselves; for when pigeons have plenty of food, they do not wait for the total dismission of their young; it being a common thing to see young ones fledged, and eggs hatching at the same time and in the same nest.*

7538. *The terms applied to pigeons of different ages are, the youngest, when fed by the cock and hen, squabs, at which age they are most in demand for pies. Under six months of age, they are termed squeakers; at that age they begin to breed, and then, or earlier, they are in the fittest state for removal to a strange situation.*

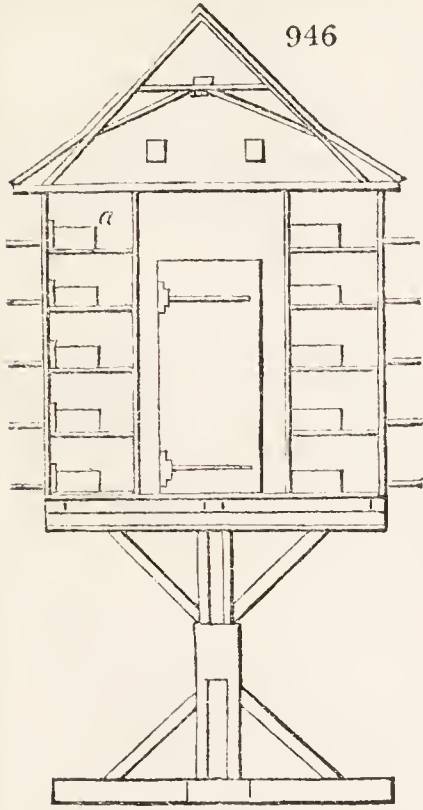
7539. *In respect to food, pigeons are entirely granivorous, and very delicate and cleanly in their diet; they will sometimes eat green aromatic vegetables, but are fondest of seeds; and tares, and the smallest kind of horse-beans, is the most suitable food both in point of economy and fattening qualities. Peas, wheat, buck-wheat, and even barley, oats, &c., are also eaten by pigeons, but old tares may be reckoned their very best food; new tares, peas, or beans, are reckoned scouring. Wherever pigeons are kept, the best way to keep them chiefly at home, and thereby both prevent their being lost, and their doing injury to corn-crops, is to feed them well: this is also the only way in which, in modern times, they will afford abundance of fat and delicate squabs for the table, which, well fed, they will do every month in the year, and thus afford a constant supply of delicate stimulating food. Pigeons are generally fed in the open air adjoining their cote or house; but in inclement weather, or to attach new pigeons to their home, both food and water should be given internally. That this may be done without waste, and without frequently disturbing the birds, two contrivances are in use: the first is the meat-box, or hopper, from whence grain or pulse descends from the hopper as eaten out of a small shallow box; the next is the water-bottle, an ovate, long, naked bottle, reversed in a small basin to which it serves as a reservoir. Any bottle will do, but the pigeons are apt to alight on and dirty such as when reversed present a flat top.*

7540. *Pigeons being fond of salt, what is called a pigeon-cat is placed in the midst of the pigeon-house, or in the open air near it. It seems these birds are fond of salt and hot substances, and constantly swallow small stones to promote digestion. The salt-cat is thus composed. Gravel or drift-sand, unctuous loam, the rubbish of an old wall, or lime, a gallon of each (should lime be substituted for rubbish, a less quantity of the former will suffice); one pound of cummin-seed, one handful of bay-salt; mix with stale urine. Inclose this in jars, corked or stopped, holes being punched in the sides, to admit the beaks of the pigeons. These may be placed abroad. They are very fond of this mixture, and it prevents them from pecking the mortar from the roofs of their houses, which they are otherwise very apt to do.*

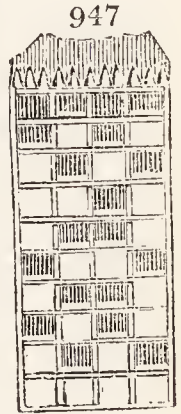
7541. *Cleanliness is one of the first and most important considerations: the want of it in a dove-cote will soon render the place a nuisance not to be approached; and the birds, both young and old, will be so covered with vermin, and besmeared with their own excrement, that they can enjoy no health or comfort, and mortality is often so induced. Mowbray's were cleaned daily, thoroughly once a week, a tub standing at hand for the reception of the dung, the floor covered with sifted gravel, often renewed.*

7542. *Pigeon-houses are of three kinds, small boarded cases fixed on posts, trees, or against the ends of houses; lofts fitted up with holes or nests; and detached buildings. The first are generally too small to contain a sufficient brood, and are also too subject to variations of temperature; and the last, on the other hand, are now-a-days too large, and therefore the most suitable for the farmer is a loft or tower rising from a building in which no noisy operation is carried on. The lofts of any of the farm-buildings at a distance from the threshing machine are suitable, or a loft or tower over any detached building will answer well; but the best situation of all is a tower raised from the range of poultry-buildings, where there is such a range, as the pigeons can thus be more conveniently treated, and will feed very readily with domestic poultry. For a tower of this sort, the round form should be preferred to the square; because the rats cannot so easily come at them in the former as in the latter. It is also much more commodious; as, by means of a ladder turning round upon an axis, it is possible to visit all the nests in the house, without the least difficulty; which cannot be so easily done in a house of the square form. And in order to hinder rats from climbing up the outside of it, the wall should be covered with tin-plates to a*

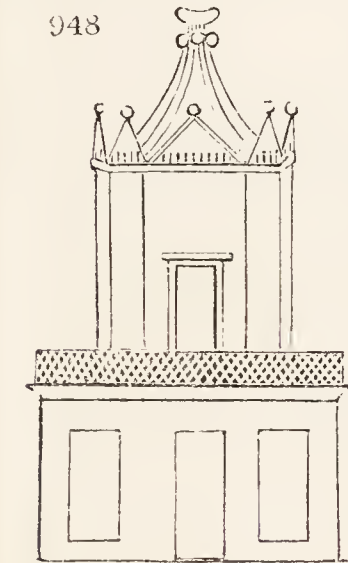
certain height, as about a foot and a half; which should project out three or four inches at the top, to prevent their getting up more effectually. A common mode in France is to raise a boarded room on a strong post powerfully braced (fig. 946.), the interior sides of which are lined with boxes for the birds (a), and the exterior east and west sides with balconies, or sills for them to alight on and enter their boxes (b). The north and south sides are lined with boxes inside, but without openings, as being too cold on the one front, and too warm on the other.



7543. *The interior of the pigeon-house* must be lined with nests or holes; subdivided either by stone, as in the ancient mural pigeon-houses; by boards; or each nest composed of a vase or vessel of earthenware fixed on its side. Horizontal shelves (fig. 947.), divided vertically at three feet distance, are generally esteemed preferable to every other mode; the width of the shelf may be twenty inches, the height between shelf and shelf eighteen inches; and a slip of board three or four inches high is carried along the front of the partitions to keep in the nests. Sometimes, also, a partition of similar height is fixed in the middle of each three-foot division, which thus divides it into two nests. This Mowbray and Girton concur in recommending, as likely to prevent the young from running to the hen when sitting over fresh eggs, and perhaps occasioning her to cool and addle them; for when the young are about a fortnight or three weeks old, a good hen will leave them to the care of the cock, and lay again. Some prefer breeding-holes with no board in front, for the greater convenience of cleaning the nests; but as the squabs are apt to fall out by this practice, a good way would be to contrive the board in front to slip up and down in a groove, by which each nest might be cleaned at pleasure. As tame pigeons seldom take the trouble of making a nest, it is better to give them one of hay, to prevent the eggs from rolling. There are also straw buckets made in the form of nests, and also nests or pans of earthenware. Where pans are used, it is common to place a brick between them (two being placed in a breeding hole), for the cock and hen to alight on; but on the whole straw



nests are best. The pigeon-house has two entrances, one a common-sized door for man, either on the ground level, or to be ascended to by a ladder, as used formerly to be the case; and the other on a rising above the roof, and consisting of small holes three or four by twelve or fourteen inches, for the entrance of the pigeons. A series of ranges of these are generally placed over each other, in a boarded front looking to the south, with a shelf to each range, and surrounded by a row of iron spikes to protect them from cats. The elevation of pigeon-houses (fig. 948.), as already described, are of endless variety.



7544. *The breeding holes* constitute the fixtures of the pigeon-house; its utensils are the hopper and bottle already described (7539.), a barrel or box for food, a step ladder to reach the nests, and some other articles not peculiar to this department of rural economy. The pigeon-trap, for enticing and entrapping the pigeons of others, we do not describe.

7545. *Pigeons in new lodgings* are apt sometimes to forsake their habitations. Many nostrums have been recommended to prevent them from doing so; but if squabs be selected, cleanliness and security attended to, and a salt cot placed in or near the house, there will be little danger of this taking place. Fumigation with highly odoriferous drugs, or even assafetida, is also said to attract pigeons to a neglected dove-cote, or attach them to a new one.

7546. *Diseases of pigeons.* Fancy pigeons, being many of them monstrous productions, are very subject to diseases. Girton enumerates upwards of a dozen, with their cures, including the corruption of the egg in the uterus from over high feeding; a gorged crop from voracious feeding; insects from filthiness in the pigeon-house, and the canker from cocks fighting with each other. Little can be done in the way of curing any of these diseases otherwise than by recurrence to the proper regimen: if this does not speedily take effect, it is better to put the bird *hors de peine*, both for humanity's sake and to prevent infection. Fortunately, the common pigeon reared for the table is little liable to diseases.

7547. *Laws respecting pigeons.* By the 1st of James, c. xxvii, shooting, or destroying pigeons by other means, on the evidence of two witnesses, is punishable by a fine of 20s. for every bird killed or taken; and by the 2d of Geo. III. c. xxix. the same offence may be proved by one witness, and the fine is 20s. to the prosecutor. Any lord of the manor or freeholder may build a pigeon-house upon his own land, but a tenant cannot do it without the lord's licence. Shooting or killing within a certain distance of the pigeon-house, renders the person liable to pay a forfeiture.

7548. *The common pheasant* (*Phasianus colchicus L.*) is a native of the old continent, but not of America, and has long been naturalised in the warmer and most woody counties of England. It is very common in France, and before the Revolution used to be a great nuisance to the farmers, even to the gates of Paris. The pheasant runs fast, but flies low and heavily; it crows not unlike the common cock, being of the same genus, and is supposed to live six or eight years.

7549. *Pheasants are both granivorous and carnivorous;* they feed upon all sorts of insects and vermin like the peacock, and are said to be greedy of toads, when not too large to swallow; whereas, according to report, they will not touch the frog, of which ducks are so fond. They are prized in park scenery for their beautiful plumage and showy figure, and as game for the delicacy of their flesh, which is of a high flavour and alkaliescent quality. It is in season in autumn, and most esteemed when under a year old, and very fat. Every gentleman who has a well wooded, well enclosed park, and in whose woods are abundance of such evergreens as the spruce fir, holly, box, broom, &c., may stock it with pheasants; and he may preserve his stock if he will continue to supply them with abundance of food, and deter thieves, polecats, &c. The more common the pheasant becomes, the less will it be subjected to the attacks of those enemies.

7550. *Varieties.* Besides that which may be considered common or wild in this country, and which is generally of a brown colour, there is the *gold* and *silver*, natives of China, and very hardy in this country, and good breeders. The ring-necks, natives of Tatory, bred in China, very scarce; their plumage very beautiful. The white and pied; both sorts will intermix readily with our common breed, as will the Bohemia, one of the most beautiful of its kind, and equally scarce. The golden variety is generally of the highest price, and the common most hardy, and of the largest size.

7551. *Breeding.* In a wild state the hen pheasant lays from eighteen to twenty eggs in a season, but seldom more than ten in a state of confinement. As this bird has not hitherto been domesticated, and as the flesh of those brought up in the house is much inferior to that of the wild pheasant, they are chiefly bred for show, for replenishing a park, or for turning out in well enclosed reclusive scenes, which they will not readily leave if well fed, and not much disturbed. Hence every proprietor may naturalise them at least on a part of his grounds; say, for example, a wood with glades of pasture enclosed by a close paling or high wall. The natural nest of the pheasant is made on the ground, and composed of dry grass and leaves, which being provided for her in confinement, she will always arrange properly. They will breed freely with the common fowl; but as neither flesh nor form are improved by the cross, this is seldom resorted to.

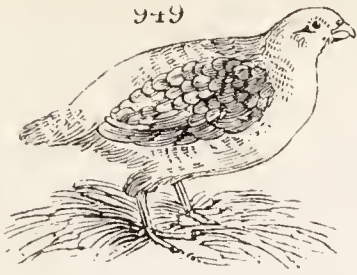
7552. *In stocking a pheasantry,* the general mode is to procure eggs from some establishment of this sort or otherwise; and the following are the directions of Castang, as given in Mowbray's *Treatise on Poultry*: — Eggs being provided, put them under a hen that has kept the nest three or four days; and if you set two or three hens on the same day, you will have the advantage of shifting the good eggs. At the end of ten or twelve days, throw away those that are bad, and set the same hen or hens again, if setting-hens should not be plenty. The hens having set their full time, such of the young pheasants as are already hatched put into a basket, with a piece of flannel, till the hen has done hatching. The brood now come, put under a frame with a net over it, and a place for the hen, that she cannot get to the young pheasants, but that they may go to her; and feed them with boiled egg cut small, boiled milk and bread, alum curd, ants' eggs, a little of each sort, and often. After two or three days they will be acquainted with the call of the hen that hatched them, may have their liberty to run on the grassplat, or elsewhere, observing to shift them with the sun, and out of the cold winds; they need not have their liberty in the morning till the sun is up; and they must be shut in with the hen in good time in the evening. Every thing now going on properly, you must be very careful (in order to guard against the distemper to which they are liable) in your choice of a situation for breeding the birds up; and be less afraid of foxes, dogs, polecats, and all sorts of vermin, than the distemper. Castang had rather encounter all the former than the latter; for those with care may be prevented, but the distemper once got in is like the plague, and destroys all your hopes. What he means by a good situation is nothing more than a place where no poultry, pheasants, or turkeys, &c. have ever been kept; such as the warm side of a field, orchard, pleasure-ground, or garden, or even on a common, or a good green lanc under circumstances of this kind, or by a wood side; but then it is proper for a man to keep with them, under a temporary hovel, and to have two or three dogs chained at a proper distance, with a lamp or two at night. He has known a great number of pheasants bred up in this manner in the most exposed situations. It is proper for the man always to have a gun, that he may keep off the hawks, owls, jays, magpies, &c. The dogs and lamps shy the foxes more than any thing; and the dogs will give tongue for the man to be on his guard if smaller vermin are near, or when strollers make their appearance. The birds going on as before mentioned, should so continue till September, or (if very early bred) the middle of August. Before they begin to shift their long feathers in the tail, they are to be shut up in the basket with the hen regularly every night; and when they begin to shift their tail the birds are large, and begin to lie out; that is, they are not willing to come to be shut up in the basket: those that are intended to be turned out wild should be taught to perch (a situation they have never been used to); this is done by tying a string to the hen's leg, and obliging her to sit in a tree all night: be sure you put her in the tree before sunset; and if she falls down, you must persevere in putting her up again till she is contented with her situation; then the young birds will follow the hen, and perch with her. This being done, and the country now covered with corn, fruits, and shrubs, &c. they will shift for themselves. For such young pheasants as you make choice of for your breeding-stock at home, and likewise to turn out in spring following, provide a new piece of ground, large and roomy for two pens, where no pheasants, &c. have been kept, and there put your young birds in as they begin to shift their tails. Such of them as you intend to turn out at a future time, or in another place, put into one pen netted over, and leave their wings as they are; and those you wish to keep for breeding put into the other pen, cutting one wing of each bird. The gold and silver pheasants you must pen earlier, or they will be off. Cut the wing often; and when first penned feed all your young birds with barley-meal, dough, corn, and plenty of green turnips.

7553. *A receipt to make alum curd.* Take new milk, as much as your young birds require, and boil it with a lump of alum, so as not to make the curd hard and tough, but custard-like. Give a little of this curd twice a day, and ants' eggs after every time they have had a sufficient quantity of the other food. If they do not eat heartily, give them some ants' eggs to create an appetite, but by no means in such abundance as to be considered their food. The distemper alluded to above is not improbably of the same nature as the roup in chickens, contagious, and dependent on the state of the weather, and for prevention requiring similar precautions. When a pheasantry is connected with a piece of ground covered with bushes or shrubbery, the birds may be bred in houses or pens, and afterwards put out into small enclosures, say one hundred feet square, with fences twelve feet high, each containing abundance of low evergreens, especially the spruce fir, and an artificial or natural supply of water. Under such an arrangement the hen pheasant will hatch her own eggs, and the following directions are given as to attendance by the same experienced person: — Not more than four hens to be allowed in the pens to one cock. And in the out covers, three hens to one cock may be sufficient, with the view of allowing for accidents, such as the loss of a cock or hen. Never put more eggs under a hen than she can well and closely cover, the eggs fresh and carefully preserved. Short broods to be joined and shifted to one hen. Common hen pheasants in close pens, and with plenty of cover, will sometimes make their nests and hatch their own eggs: but they seldom succeed in rearing their brood, being so naturally shy; whence, should this method be desired, they must be left entirely to themselves, as they feel alarm even in being looked at. Eggs for setting are generally ready in April. Period of incubation, the same in the pheasant as in the common hen. Pheasants, like the pea-fowl, will clear grounds of insects and reptiles, but will spoil all wall-trees within their reach, by picking off every bud and leaf.

7554. *Feeding.* Strict cleanliness to be observed, the meat not to be tainted with dung, and the water to be pure and often renewed. Ants' eggs being scarce, hog-lice, ear-wigs, or any insect may be given; or artificial ants' eggs substituted, composed of flour beaten up with an egg and shell together, the pellets rubbed between the fingers to the proper size. After the first three weeks, in a scarcity of ants' eggs, Castang gives a few gentles, procured from a good liver tied up, the gentles when ready dropping into a pan or box of bran; to be given sparingly, and not considered as common food. Food for grown pheasants, barley or wheat; generally the same as for other poultry. In a cold spring hempseed, or other warming seeds are comfortable, and will forward the breeding stock.

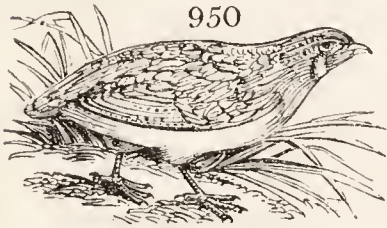
7555. *In keeping fancy pheasants,* as the gold, silver, or other breeds, the best mode is to enclose a few poles of ground containing trees and bushes with a well painted copper netting, and in some concealed part to have a house or lodge for supplying water and food. This forms by far the most elegant aviary, and is the only one that at all times appears clean. They will thrive very well, however, in an aviary on the common construction.

7556. *The partridge* (*Tétrao Pêrdrix*, *fig.* 949.) is a native of all the temperate regions of Europe, but unable to sustain rigorous cold or intense heat.



7557. *Partridges are highly valued as food* on most parts of the Continent, and as a table luxury in England. In the Ukraine both partridges and pheasants are more abundant than any where else in Europe: they were formerly so common in France, that Rozier informs us that the cultivators were obliged to sow three or four times the corn that was necessary to raise a crop, and that even this had often to be done three or four times in a season. The bird feeds like the pheasant on insects and seeds, and is particularly fond of those of the wild mustard. It has not been domesticated, but may be hatched and reared in the same manner as the pheasant.

7558. *The quail* (*Tétrao Coturnix*, *fig.* 950.) is a native of the East, and abounds in Egypt, as appears from the supplies the Israelites obtained while in the wilderness, and also in the islands of the Archipelago, and in Italy. They migrate from warmer to colder regions. They are naturalised and breed in England, changing their residence within it on the approach of winter, from the more exposed to the more temperate districts. They are very abundant in France, and are caught in snares and nets

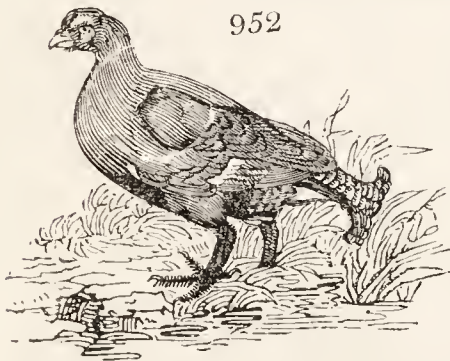


(described by Rozier), and sent both to the Paris and London markets. The bird was



proverbial among the Romans as captious and quarrelsome, and is employed among the Chinese for the same amusement as game cocks are in England. Here it is not domesticated, but may be reared and preserved in the same manner as the pheasant and partridge, and its food is nearly the same as that of the latter bird.

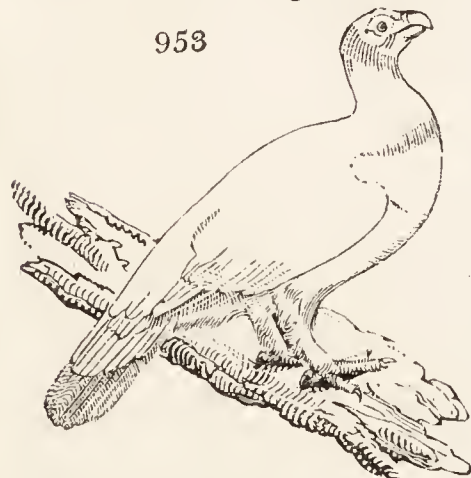
7559. *The red grouse, or moor cock*, (*Tétrao scoticus*, *fig.* 951.) is an esteemed variety of *Gallinæa*, pursued with avidity by sportsmen in the mountainous districts of England, Wales, and Scotland, in which latter it abounds, there feeding in plenty among the heather, its favourite food. Its beautiful plumage, and its exquisite flavour, render it an object of considerable interest.



7560. *The black grouse, or black cock* (*Tétrao Tètrix*, *fig.* 952.), is less common than the red grouse, and is therefore more highly prized. It is also larger, weighing nearly four pounds. Its plumage is a rich mixture of black with blue, relieved by marking of white. Its legs are also covered with very fine minute feathers; and it draws a peculiar characteristic from the curvilinear form of the tail, which branches out at the end

into two crooked expansions. In wet seasons a great mortality is frequently observed among the grouse from intestinal worms.

7561. *The wood grouse, or cock of the wood* (*Tétrao Urogállus*, *fig.* 953.), is, after the



bustard, the largest bird among those we call game; it being little less than a turkey. It was originally common in the mountainous parts of Britain; but is now nearly if not wholly extinct with us; though still common in the northern parts of Europe, where it lives in pine forests, on the cones of which it is supposed to subsist, and which at some seasons gives its flesh a terebinthinated taste: at other times it is delicious eating, and is often sent to England frozen. Like the other grouse, he has the scarlet patch on his head, his legs are defended in the same manner by a feathered covering, and his whole markings are equally varied and beautiful. From the richness of the plumage in all the varieties of the *Tétrao*, and from the extreme delicacy of their flesh as

an article of food, it is to be lamented that attempts are not made to domesticate them in addition to our other poultry. It is thought by observant sportsmen and scientific naturalists, that this might be attended with less difficulty than the domesticating the partridge and pheasant; and the attempt is recommended to the patriotic amateur.

7562. *The lark* (*Alaúda arvensis* L.) and other birds were reared and fattened by the Romans for the table. The lark is caught by nets and other means in some of the open districts of England, as about Dunstable, Cambridge, &c., and brought to market for the table, as are various other birds by a particular class of men known as bird-catchers. It is an idle uncertain kind of life not to be recommended.

7563. *Of singing birds*, a great variety are domesticated; and their breeding and rearing forms a very peculiar and curious branch of rural economy. Not only all the birds which please by the natural song are domesticated and kept in cages, as the canary, nightingale, lark, linnet, finch, thrush, &c.; but even some which do not sing in a wild state, as the sparrow, hammer, &c., are by art taught the notes of other birds.

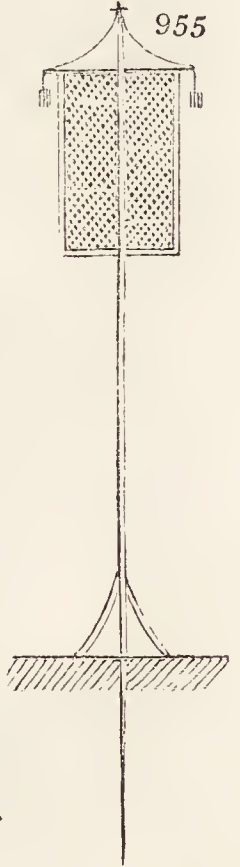
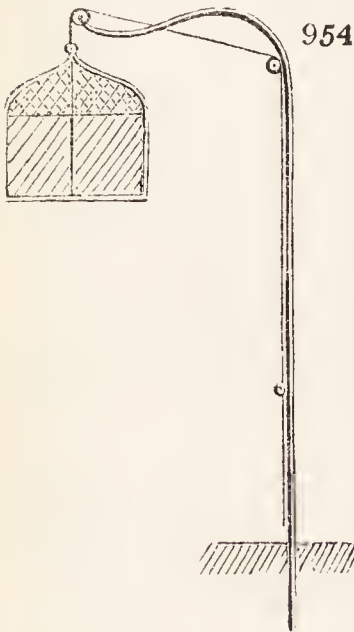
7564. *Wild singing birds* are caught by various devices, according to the species of bird and season of the year. The pairing season in spring, generally March and April, is on the whole the best season, and the common means are a net called a clap-trap; a bird of the species to be caught, called a call-bird, to attract the wild one; and another, a female, called a brace-bird. Bird-lime is also very generally used; and for nightingales, a small hole dug in the ground covered with a perforated board, or a small round spring trap, called a nightingale trap, is resorted to. Glasses called larkers are used to call larks, and hawks are used to frighten some species, to render them more readily taken. As it is only the male birds which sing, or at least are of any value for their song, it is a very material part of the bird-fancier's art to know the male from the female when they are both young; in general he is larger and longer.

7565. *In breeding and rearing tame birds* the chief art consists in teaching them to sing. This is frequently done by the human voice alone, but more commonly by the aid of the flageolet or a small barrel organ. The organ is used in Germany in teaching the nightingale-notes to the canary; and in teaching regular tunes, as marches, waltzes, &c. to the bulfinch, which after being so taught are called piping bulfinches, and cost from 5*l.* to 7 or 8 guineas each in London. In Italy the canary is taught various notes and tunes by the flageolet. In France, and also in this country, one bird is taught by another being placed in a cage near it. When not taught at all, and not within the hearing of other birds, each bird utters its natural notes but very imperfectly. In general they are more ready to imitate the note of any bird they hear, even of a hen or duck, than to utter those which are natural to the species. This certainly appears singular, but it is a well known fact.

7566. *The aviary*, or place for breeding and keeping singing birds, may be a long narrow apartment fronting the south; the front to be covered with wire netting, and within this glass sashes which may be removed in summer. There should also be a flue in the floor or back wall to supply heat in cold weather. In such a building various birds may be kept in cages, or a few sorts in compartments. Thus a considerable space may be allotted to the breeding of the canary, for which there is the greatest demand; the next largest to the linnet and nightingale; and any others may be kept in cages. Indeed, singing birds are invariably found to sing best when kept in separate cages, and apart from each other. In gardens or pleasure-grounds these cages may be suspended from trees, or supported by light iron props (figs. 954, 955.); and those who would wish to pursue this branch, either as one of amusement or profit, will find ample instructions in *Thomson's Bird Fancier*, and other similar works.

7567. *Foreign aquatic birds* may be kept in the artificial waters of pleasure-grounds by shortening the feathers of one wing, and without any other care than a duck-house or shelter during night.

7568. *The training of hawks and other birds for hunting*, of decoy birds of different sorts, as ducks, singing birds, pigeons, &c., belongs more to sportmanship than agriculture, and may be learned in *Daniel's Rural Sports*, and various old books, such as *The Country Gentleman's Recreation*, &c.



CHAP. X.

Fish and Amphibious Animals subjected to Cultivation.

7569. *The cultivation of fish* is carried on to a very limited extent in Britain, owing to the great superiority of the sorts obtained by fishing in rivers or the sea, and to the decline of the catholic religion, which no longer renders fish an article of importance on certain days and seasons. However, in a few places fish are bred and reared for the market, and in gentlemen's grounds in the interior of the country some attention is generally paid to stocking the ornamental pieces of water with appropriate fish. Bakewell, in his instructive *Travels in the Tarantaise*, suggests the idea of introducing exotic fish and naturalising them in our lakes and rivers, and he mentions some Swiss species that he thinks would be particularly valuable. In the *Edinburgh Review* for 1822, is a curious paper on the possibility of rearing sea-fish in our fresh water lakes. See also *Brandé's Quarterly Journal*, Nos. xxxiii. and xxxiv. It appears that the flounder and the mullet have been naturalised to fresh water; and that it is probable the whole of the fishes of analogous habits, and particularly those of the genus *Pleuronectes*, might be habituated to inland lakes.

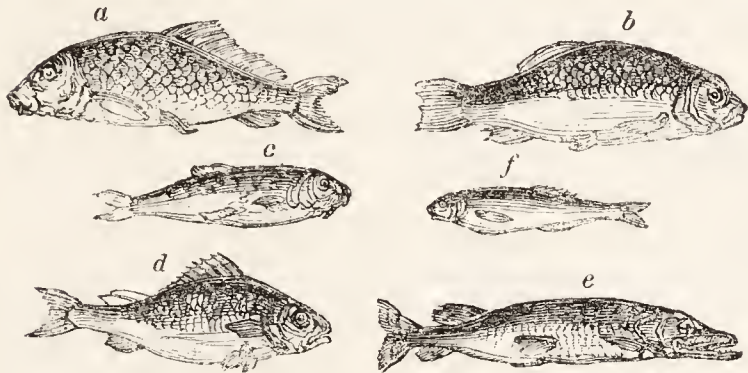
7570. *The mode of constructing ponds* for retaining water for general purposes has been already described. (4467.) Ponds, expressly for the purpose of breeding and rearing fish, are formed at least expense in deep valleys, and slight depressions between hills, where there are rivers or waters; and

different ones may often be made on the same line, the head of one constituting the bottom of that above it. The extent of them must be regulated by the nature of the situation, and the supplies of water that can be procured. In situations of this nature, the principal expense consists in constructing the banks or heads across the valleys, for keeping up the waters, and providing them with suitable sluices, which, where the land is of the loamy or clay kind, may be cheaply effected in the manner that earth works are usually performed. The foundations being laid sufficiently deep, and the earthy materials well applied by proper puddling and ramming, in the way of making embankments. The heights and strength of the dams or heads being regulated by the nature of the situations, and the quantity of water that is to be dammed up. The slopes should be the greatest which are next the waters. There must also be diverting channels for taking off the superabundant waters in the time of floods, which may be formed along the sides; the sluices being placed in the lowest parts, and being well made of seasoned oak, and tightly rammed in with the earthy materials. Detailed instructions on this subject will be found in the *Quarterly Journal of Agriculture*, vol. i. p. 297.

7571. *Sea water fish-ponds* are unknown on the Continent, and not common in England. In Scotland, however, there are several, which are stocked chiefly with turbot, cod, haddock, whiting, thornback, coal-fish, and salmon. One of the largest and best of these fish ponds is that of Macdonnel of Laggan, in Wigtonshire, which has been in existence for upwards of thirty years. (*Macdiarmid's Sketches from Nature*, and *Highland Soc. Trans.* vol. vii. p. 297.)

7572. *The kinds of fish adapted for ponds* are chiefly the carp, tench, perch, gudgeon, eel, and pike.

7573. *The carp* (*Cyprinus Carpio L.* fig 956. a) is by far the best fish for artificial management, and especially that variety known in England as the Prussian carp. Carp inhabits the slow and stagnant waters of Europe and Persia, and was introduced into Britain in the year 1514; about four feet long; grows fast and is very long-lived; feeds on herbs, fat earth worms, and aquatic insects, and any soft substance; is extremely fertile, and the prey of larger fish, aquatic birds, and frogs; body above blue-green, the upper part of the sides greenish-yellow and blackish, beneath whitish; tail yellow; scales large, longitudinally striate; of the gall is made a green paint, and of the sounds or air-bladder a fish-glué.



7574. *In raising carp*, it is often the practice to have three ponds: — One for the purpose of spawning the fish in, and in which they should be left during the rest of the summer and the following winter, as they mostly spawn from the beginning of May to the latter end of July; another for the convenience of nursing up the young fry, into which they should be put about the latter end of March or the beginning of April, choosing a calm but not sunny day for the business; after which they should be carefully prevented from coming to the sides and being destroyed: in this pond they may remain two years, and become four, five, or six inches in length, and good for use. The third or main pond is destined for the reception of the grown fish, as those that measure a foot or more, including the heads and tails. The proportions in which these different ponds are advised to be stocked are these: — For each acre of the first sort, “three or four male carps, and six or eight female ones;” the most suitable sort for this use being “those of five, six, or seven years old, in good health, with full scale, fine full eyes, and a long body, without any blemish or wound.” The ponds should be previously cleared of all sorts of voracious fishes and other animals, as “perch, pike, eel, and trout; the water-beetle, and also the newts or lizards.” Such ponds as are warm and have an open exposure, with soft water, are the most proper for this use; all kinds of water fowl being kept from them. For the nursing ponds, a thousand or twelve hundred may not be more than sufficient for an acre; and for the main ponds, one to every square of fifteen feet is the proportion advised, as their growth depends greatly on the room and quantity of food that is allowed. The best seasons for performing the business in this case are those of the spring and autumn. Some advise, in these cases, the stocking with carp or tench in the proportion of three to a square perch. In first stocking large ponds or waters, as where they are to the extent of three or four acres, carp, in the proportion of three hundred to the acre, are recommended; and where they do not extend to such sizes, not so great a portion. And in stocking, after two or three years, four hundred to the acre.

7575. *The tench* (*Cyprinus Tinca L.*, b) inhabits almost every where in stagnant waters; grows quickly, and reaches from four to eight pounds weight; is very fertile and tenacious of life, and will live all the winter under the ice; feeds on worms and water plants; is very foolish, and may be easily caught; body covered with a thick mucus, and small scales which adhere firmly to the skin; above dark-green, the sides above the line green, beneath yellow, belly white; varies in its colours by age, sex, or the waters it inhabits; flesh white, soft, and well tasted.

7576. *In stocking with tench* the number per acre may be more than of carp. In Berkshire, where there are many ponds for the preserving of fish, they usually stock with tench or carp in the proportion of one hundred to the acre, the fish remaining four years in them: but in the management of Sir Harry Featherstone, in Sussex, in a pond of twenty acres reduced to sixteen by the deposition of mud, the stock is generally in the proportion of twelve hundred carp and an equal number of tench; or at the rate of seventy-five brace to the acre. And in this proportion they are said to succeed well.

7577. *The gudgeon* (*Cyprinus Gobio L.*, c) is a very inferior fish to the carp or tench; but being of easy culture and rapid increase, is kept in many places as food for pike and perch. It inhabits gentle streams and lakes of Northern Europe; is tenacious of life, and very fertile; about eight inches long; feeds on herbs, worms, insects, the fry of other fish, and parts of carcasses: body narrow, spotted, above livid, the sides above the line blue, beneath whitish yellow, but it varies its colours by age, the different waters it inhabits, and its food; flesh white, and very grateful.

7578. *The perch* (*Perca fluviatilis L.*, d) is an excellent fish, and though naturally found in streams in Europe and Siberia, yet will live in large ponds or lakes, provided the water be clear. It grows to two feet long; back and part of the sides deep green, with five broad black bars, which are sometimes dark green or blue, and very rarely wanting; belly white, tinged with red; swims with great swiftness and at a certain height in the water; is tenacious of life, but eagerly takes a bait; feeds on aquatic insects and smaller fish; spawns in May and June, and is very prolific; it has no real air-bladder; and from its integuments may be obtained a kind of glue; flesh very delicate.

7579. *In stocking with perch*, as they are great breeders, six hundred to the acre may be sufficient.

7580. *The pike* (*Esox Lucius L.*, e) inhabits most lakes of Europe, Lapland, Northern Persia, and North America, and is found even in the Caspian Sea; swims, and grows very rapidly, one to eight feet long; is extremely voracious and long-lived; feeds on almost any thing which comes in its way, even its own tribe; spawns from February to April; body above black, the sides cineraceous spotted with yellow, beneath white dotted with black; rarely orange spotted with black or green; scales small, oblong, hard. The pike is best reared in deep ponds by itself in which some gudgeons may be put to breed

for its food. It will thrive in waters partaking of the chalybeate quality, in which few other fish would live.

7581. *The gold fish* (*Cyprinus auratus L.*) is an inhabitant of the rivers of China and Japan, and is naturalised almost every where on account of its elegance and vivacity; the colours vary greatly, but are naturally and mostly of a most splendid golden hue; scales large. It is bred in small ponds in gardens near London and Paris for sale, as an ornamental inhabitant of crystal vases, or garden basins of water.

7582. *The minnow* (*Cyprinus Phoxinus L., f.*), the *dace* (*C. lentiscus L.*), and the *roach* (*C. rutilus L.*), are very small fish, which abound, the first in gravelly streams, and the others in still waters; both are useful as affording food to other fish, and may therefore be put into fish ponds. They are also very good to eat.

7583. *Of the trout and salmon family* there are several species, as the lake trout, gilt and red charr, which inhabit Alpine lakes in northern countries, and might probably be introduced with advantage into the lakes of Cumberland, Westmoreland, and the Highlands of Scotland. The red charr is caught in Keswick lake. The salmon and salmon-trout (*Sálmo Sàlar*, and *S. Trútta*,) require salt water and a river; and the fresh water trout (*S. Fàrio*) requires too rapid a stream for art to imitate; they succeed, however, to a certain extent, in very slow-running waters which are clear.

7584. *The salmon* is a very prolific fish; both male and female are frequently fit for propagation during the first year of their age. The roe of the female is found, on an average, to contain from 17,000 to 20,000 ova or eggs. During the months of August, September, and October, the reproductive organs, both of the male and female salmon, have more or less completely reached maturity, at which period the instinct of propagation impels them eagerly to seek rivers, and to ascend nearly to their sources, in order to find a place suitable for the deposition of their spawn. They no longer, as in the winter and spring months, roam over the coast and shores, and return backwards and forwards with the flowing and ebbing of the tide; but pursue the most direct route by the mid-channel up the rivers, and make the greatest efforts to overcome every obstacle, either natural or artificial, that may impede their progress. The spawning is accomplished in the months of November, December, and January. When the parent fishes have reached the spawning ground, they proceed to the shallow water, generally in the morning, or at twilight in the evening, when they play round the ground two of them together. After a turn, they begin to make a furrow, by working up the gravel with their noses rather against the stream; as the salmon cannot work with his head down the stream, for the water then going into his gills the wrong way, drowns him. When the furrow is made, the male and female return to a little distance, one to the one, and the other to the other, side of the furrow. They then throw themselves upon their sides, again come together, and rubbing against each other, both shed their spawn into the furrow at the same time. This process is not completed at once; as the eggs of the roe must be excluded individually, from eight to twelve days are required for completing the operation. When the process is over, they betake themselves to the pools to recruit themselves. The spawn thus deposited is afterwards covered with loose gravel; and in this state the ova remain for weeks, or sometimes much longer, apparently inert, like seeds buried in the soil. In an early spring the fry come forth early, and later when the spring is late. Generally, they begin to rise from the bed about the beginning of March, and their first movement is generally completed by the middle of April. The appearance which they present is that of a thick braid of grain rushing up in vast numbers. The tail first comes up, and the young animals often leave the bed with a portion of the investing membrane of the ovum about their heads. From experiments that were made upon the roe, it appears that they can only be hatched in fresh water; for when a portion of the roe was put into salt water, none of the ova ever came into life; and when a young fish that had been hatched in fresh water was put into salt water, it showed symptoms of uneasiness, and died in a few hours. When the evolution from the ova is completed, the young fry keep at first in the eddy pools, till they gain strength, and then prepare to go down the river, remaining near its sides, and proceeding on their way till they meet the salt water, when they disappear. The descent begins in the month of March, continues through April and a part of May, and sometimes even till June. The reason why the fry thus descend by the margin in rivers, and the mid-channel in estuaries, is apparently, according to Dr. Fleming, because the margin of the river is the easy water, and consequently best suited to their young and weak state: but when they reach the estuary or tide-way, then the margin of the water being the most disturbed, the fry avoid it, and betake themselves to the deepest part of the channel, disappearing alike from observation and capture, and so go out to sea. After remaining some weeks at sea, the smelts or samlets, as the fry are called, return again to the coasts and rivers, having obtained a pound or a pound and a half of weight; by the middle of June they weigh from two to three pounds, and are said to increase half a pound in weight every week. They are now known in Scotland by the name of grilises, and by the end of the fishing season they have obtained the size of seven or eight pounds. In the first five months of its existence, that is, from April to August, both inclusive, it may be stated that the salmon reaches, in favourable circumstances, eight pounds weight, and afterwards increases, though more slowly, yet so as to have acquired the weight of thirty-five pounds in thirty-three months. After the process of spawning is completed in the river, the parent fishes retire to the adjoining pools to recruit. In two or three weeks from that time, the male begins to seek his way down the river; the female remains longer about the spawning ground, sometimes till April or May. The fishes which have thus spawned are denominated kelts. In their progress to the sea, when they reach the estuary, they pursue a course precisely similar to the fry, not roaming about the banks like clean fish, but keeping in the mid-channel. They are at this time comparatively weak; and in thus betaking themselves to the deepest part of the channel, they are better able to resist the deranging effects of the flood-tide, and to take advantage of the ebb tide in accelerating their migration to the sea. It appears that some which descend as *kelts* in spring return again in autumn in breeding condition, a recovery which is no less remarkable than the early growth of these animals. The sea seems to be the element in which the salmon feeds and grows. When caught in fresh water, not only is their condition comparatively poor, but scarcely any thing is ever found in their stomachs. In estuaries and on coasts, on the other hand, they feed abundantly, and their stomachs are often found full of sand-eels. (*Edin. New Phil. Jour.* Jan.—April, 1828.)

7585. *The eel* (*Muraena Anguilla L.*) inhabits almost every where in fresh waters; grows sometimes to the length of six feet, and weighs twenty pounds; in its appearance and habits something resembles the serpent tribe; during the night quits its element, and wanders along meadows in search of snails and worms; beds itself deep in the mud in winter, and continues in a state of rest; is very impatient of cold, and tenacious of life: the flesh of such as frequent running water is very good; is viviparous, and has 116 vertebræ. One advantage of the eel is, that it will thrive in muddy ponds of very small size, where no other fish would live.

7586. *On the subject of cultivating fishes* it may be observed, that the waters of some ponds are better adapted for raising some sorts of fish than others. Thus, those where the water is rich and white are more adapted for carp; while such as have a thicker appearance, and where there is a greater deposition of muddy matter, are better suited to tench. Perch are capable of being raised in almost any sort of ponds. Eels succeed best where the ponds are not very large; but where fed by a spring, and there is a large portion of rich sediment. Pike should never be kept in ponds with carp or tench; but in separate breeding-ponds, where the supplies of small fry are considerable and not wanted for stores. Carp, tench, and perch are the sorts principally cultivated with a view to profit, with a few eels occasionally. But perch and eels should not be admitted where the ponds are but thinly stocked, as they are great devourers of the young fish. Carp and tench answer best together where the extent of the ponds are pretty large; as, in other cases, the former, from being a much more powerful fish, beats and deprives the latter of his

food. Carp seldom afford much profit in ponds of less extent than half an acre; but tench thrive well in those of almost every size, being often found good in ponds of only a few perches square. Carp, perch, and eels succeed well together; and also tench and eels. Carp more frequently injure themselves by breeding than tench, though it sometimes happens with the latter. It is not improbable, but that in small ponds it may be the best practice to keep the carp and tench separate. The produce or profit afforded by fish-ponds has not yet, perhaps, been sufficiently attended to in different situations to afford correct conclusions; nor is it well ascertained what is the annual increase in weight in fish of different kinds, in different periods of their growth, and under different circumstances of soil and water. Loveden (*Annals of Agriculture*) states, that in Berkshire a pond of three acres and a half, drawn after being stocked three years with stores of one year old, produced of carp 195 lb. weight, of tench 230 ditto; together 425 lb., which sold for 20l. 10s. or nearly 2l. 6s. per acre per annum.

7587. *The taking of cultivated fish* is generally done with nets, and sometimes by emptying the pond of water. Whatever way is adopted, only those fit to be used are taken, and the rest returned to grow larger. No fish is taken, or fit to be used, for a month before and after the spawning season, which with most fresh water fish is in April, May, or June. The Marquis de Chabanes proposes to catch fish, both in fresh and salt water, by immersing a burning lamp in an air box with mirrors, and round which he has traps into which the animals are to be entangled, while approaching the light and the multiplied images of their own species. For this contrivance he has taken out a patent. Salmon are sometimes caught by torch-light.

7588. *The castration of fish* has been successfully practised both in this and other countries, and both with the male and female. Castrated fish attain to a larger size, and are in season at any period of the year. The mode of performing the operation is described in Rees's *Cyclopædia*, art. *Fish, Castration of*; and in the *Philosophical Transactions*, vol. 48. part ii. p. 106.

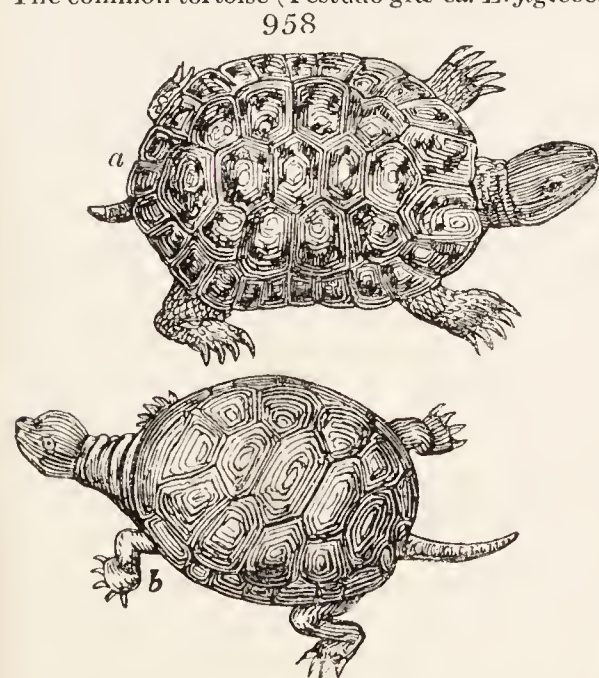
7589. *Of the amphibia* which are or may be cultivated for food or ornament, the principal are the frog and tortoise.

7590. *The esculent frog* (*Rana esculenta L.*, fig. 957. a), though generally despised in this country, is yet an excellent article to those who are accustomed to it; and there are few Englishmen who have eaten a *fricassée* of the thighs of this animal in France or Italy, but what would wish to do so again. The body of this frog is green, with three yellow lines, the middle ones extending from the mouth to the anus, with the angles of the mouth distended in a globular form; the male makes a continual croaking in an evening, especially before rain; when irritated will pursue and destroy a pike. It is rare in England, but very common on the Continent, where it is in season for the table in June.



7591. *The tree frog* (*Rana arborea L.*, b), is green above, and whitish beneath, with a yellow curved line on the side. In elegance and activity it is superior to every other European species. In summer it resides in the woods, and haunts the trees in quest of insects, which it approaches on its belly in the same manner as a cat to a mouse, and at length seizes with an elastic and instantaneous spring. It is particularly noisy on the approach of rain. In winter it takes up its abode in the bottom of the waters, remaining till the spring in a state of torpor. The noise of this frog is by many considered musical, and it is often kept in houses in Germany both as a curiosity and as a weather guide. It certainly deserves introduction to this country. We brought one from Carlsruhe, in 1828, which has remained in a glass jar covered with gauze at the top, living on flies, till the present day, Nov. 2. 1830.

7592. *There are two species of tortoise* which might be cultivated; the common, and the mud tortoise. The common tortoise (*Testudo græca. L.* fig. 958. a) weighs three pounds, and the length of its shell is about seven inches. It abounds in the countries surrounding the Mediterranean, and particularly in Greece, where the inhabitants not only eat its flesh and eggs, but frequently swallow its warm blood. In September or October it conceals itself, remaining torpid till February, when it re-appears. In June it lays its eggs, in holes exposed to the full beams of the sun, by which they are matured. Tortoises attain most extraordinary longevity, and one was ascertained to have lived in the gardens of Lambeth to the age of nearly one hundred and twenty years. It will answer the purpose of a barometer, and uniformly indicates the fall of rain before night, when it takes its food with great rapidity, and walks with a sort of mincing and elate step. It appears to dislike rain with extreme aversion, and is discomfited and driven back only by a few and scarcely perceivable drops.



7593. *The mud tortoise* (*T. lutaria, b*) is common both in Europe and Asia, and particularly in France, where it is much used for food. It is seven inches long; lays its eggs on the ground, though an aquatic animal; walks quicker than the land tortoise; and is often kept in gardens, to clear them from snails and various wingless insect. In fish ponds it is very destructive, biting the fishes, and, when they are exhausted by the loss of blood, dragging them to the bottom and devouring them. The tortoise may be fed on any vegetable refuse, milk, worms, offal, or almost any thing. Linnæus says

they are in all things extremely slow, and in copulation frequently adhere together a month, and live several days after the head is cut off. (*Shaw's Zoology*.)

CHAP. XI.

Insects and Worms which are or may be subjected to Culture.

7594. *The silkworm and the honey-bee* are the two most valuable insects in Europe. The first, from its great importance, has recently engaged the attention of the legislature, no less than of private individuals, who have embarked large sums in the attempts now making to introduce its culture in this country on a large scale.

7595. *The silkworm* is the larva or caterpillar of a moth (*Bómbyx mòri F.*, *fig.* 959.):



it is a native of China, and was introduced into Europe A. D. 160. When full grown the worm is nearly three inches long, of a yellowish grey colour, with a horn-like process on the last joint of the body.

7596. *In Italy and other silk countries* the eggs are carefully preserved in some place of cool and even temperature, where they remain until the new leaves of the white mulberry, which is its natural food, are produced. The object is to hatch the eggs precisely at this time, that the new-born worm may be fed on food suitable to its infant state. A grower of silk never hatches his whole stock of eggs at once, as a night's frost will frequently destroy the leaves. Lettuce answers well in *this* stage of the worm's existence; but if it is fed entirely upon this plant the silk is of a very inferior description, and is, indeed, perfectly useless. The pabulum of the white mulberry, in fact, is superior in nutritious matter to that of all others. The leaves in the autumn succeeding to those stripped in the spring, are commonly given to cattle and pigs, who fatten upon them exceedingly. There is an unfounded prejudice in many silk countries that the silk produced from the second leaf is inferior to the spring crop, and in France and Italy the vernal leaf only is used. In India the mulberry tree is grown in moist places, like the osier in England, and produces from three to six crops annually: the prejudice therefore of the Italian and French growers against the second crop is unfounded. The real fact seems to be, that the worms are more difficult to breed in autumn than in spring, from the great change of temperature, against which the growers in general make no artificial provision. Another reason may probably be, that the silk is reeled with greater economy and advantage in the height of summer, when the length of the days, and the heat of the weather, is then sufficient to dry the thread in this operation. The native reelers of these countries are entirely unaccustomed to use artificial methods for creating a regulated temperature in houses or manufactories.

7597. *The ventilation and cleanliness of the nursery or feeding apartments*, and the preservation of a regular heat within them, are highly important to the health of the worm. These points are much neglected on the Continent, where the nurseries are usually situated in the midst of the mulberry plantations, exposed to the external air, and seldom cleaned. It was satisfactorily ascertained by M. Guyton de Morveau a few years ago, that a ruinous and unexpected mortality, which then raged among the worms, arose chiefly from want of ventilation and cleanliness. It has likewise been proved, by experiments lately made on a sufficiently large scale in Devonshire, that less mortality prevails among the worms in England than either in France or Italy.

7598. *In about six weeks the worm reaches its full size*, previously casting its skin four times, and abstaining from food for some time before each change; at these periods the worms are very sickly, and a great mortality generally takes place. When full grown and about to spin, they exhibit symptoms of restlessness and uneasiness; small twigs of birch, or of other slender trees, are set up in the boxes or shelves; upon these the worms climb, each fixing upon its own berth. As it sometimes happens that two worms spin together, forming what is called a double cocoon, this must be carefully prevented by separating them; such a cocoon not only being difficult to run off when reeled, but two fibres are produced injurious to the size of the thread: the double cocoons are therefore always wound off by themselves. In preparing its case or cocoon, the worm first forms a loose envelopement of silken fibres, and then proceeds to enwrap itself in a ball or case of an oval form, and finally changes into the pupa or chrysalis; and after being thus enclosed for about fifteen days, becomes a moth. This, however, is always prevented when the animal is not kept for breeding, otherwise the hole formed by the moth in effecting its escape would destroy the continuity of the silk, and prevent its reeling. The chrysalides are killed by two processes, by baking in an oven, or by letting steam into a tight chest enclosing the cocoons. The latter method is preferable, as the heat can be better regulated.

7599. *The cocoon*, after the chrysalis is killed, is either reeled off at once, or sold to others who make this a distinct trade. The silk, as formed by the animal, is so very fine, that if each cocoon was reeled separately it would be totally unfit for use; the ends of four are therefore joined and reeled together out of warm water, which softening their natural gum, makes them stick together so as to form one strong smooth thread. When the filament of any single cocoon breaks, or is exhausted, its place is supplied by a new one, so that the united thread may be wound to any length; the single filaments of the newly added cocoons are simply joined by being laid on the thread, to which they adhere by their gum. The old apparatus for reeling merely consists of a large metal basin of water, under which is a fire to keep it hot, and a reel of a poor and even rude construction: some important improvements, however, have been recently made in this machine. In reeling it is desirable that a round thread of equal thickness and smoothness should be produced, having the filaments of which it is composed as equal and as firmly united as possible. When the skein is quite dry, it is taken off the reel, and a tie is made with refuse silk at its two ends; it is then doubled into a hank, and is ready for sale. In this state it arrives in England, and is called raw

silk : the principal part is afterwards sent to a mill to be thrown, that is, to be twisted singly, or to have two or more ends of it doubled and twisted together to form singles, tram, or organzine, in order to fit it for the loom. There are, however, purposes for which a single untwisted thread is applied. We have before stated that a single thread is generally composed of the filaments from four cocoons, and four of these threads compose the organzine, or that used as the warp of fabrics; each thread is first spun or twisted, and then the four are thrown together into one. The weft or tram generally consists of four raw threads simply twisted together. The reason of drawing so fine a silk on the reel as that composed of four cocoons, is, that the *fileuse*, or attendant at the basin, cannot perfectly see more cocoons in one set, so as to replace the ends when the cocoons are exhausted. If a thread of sixteen cocoons were to be reeled, the *fileuse* could not ensure regularity. Sometimes she would have only eight or ten running, and at the next moment possibly twenty; consequently a most uneven silk would thus be produced: to prevent this evil, four cocoons are only run at once, and combined as before described. The important invention of Mr. Heathcoat, which we shall hereafter notice, applies to the object of drawing off sixteen or more cocoons at once on the reel, so as to form a thread as even as that produced by four cocoons, and thus abridge the expense of the subsequent processes of throwing. We understand this invention is fully appreciated by the reelers abroad, and by the manufacturers at home, and that it produces an astonishing improvement in the quality of the silk, and a great reduction in its price. Mr. H. has obtained patents in the silk countries no less than in England for this invention, which there is every reason to think will be generally adopted.

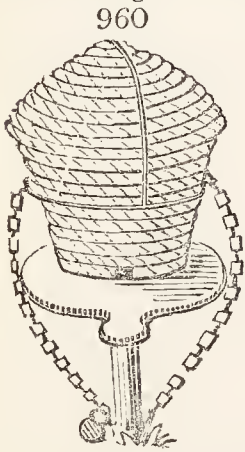
7600. *Culture of the silkworm in England.* It is well known to those who have considered the subject, that the silkworm will breed and thrive very well in England, where the range and extremes of temperature are within narrower limits than in France or Italy. The white mulberry flourishes equally well with us as in those countries. It remains, however, to be proved whether the weight of leaves produced on a given space of ground is equal to the average crop in warmer climates. This is evidently an important consideration in the question, of whether England can compete with foreign countries in the production of raw silk. The high value of land in a country so densely peopled as England, and the fact that the mulberry tree not only requires great space for its perfect growth, but also a clear ground beneath, renders the prospect of profit from this branch of agriculture very questionable. A joint stock company, in the management of which all the cabinet ministers were more or less concerned, was established in 1825, by the name of "The British, Irish, and Colonial Silk Company." They possessed a very large capital, and had formed extensive plantations of trees in several parts of England and Ireland, particularly near Windsor and Cork. Mr. John Heathcoat of Tiverton, in Devonshire, has also applied himself to the investigation of this important subject with great ardour; and, previously to the formation of the company above alluded to, had made considerable progress in the cultivation of the tree and the management of the worm. With the true liberality of a man of science, he presented to the company several thousand Italian plants destined for his own plantations, that they might commence their establishments without delay. It ought to be generally known, that to this gentleman we are indebted for the cheap production of that beautiful article called bobbin-net lace, which has become so important a branch of manufacture in England. It was in the attempt to render silk sufficiently even for his use in lace, that he made the discovery in reeling which we have before mentioned; and it is from the result of his investigations that the attention of government has so lately been directed to the subject. Admitting, as we have done, that no natural impediments exist against the successful culture of silk in England, it will naturally be asked why all attempts hitherto made have been unsuccessful? This question embraces a variety of considerations, into which our limits will not permit us to enter at large. We may, however, observe, that neither the mulberry tree nor the silkworm are indigenous to Britain. Centuries elapsed before even the south of Europe began their culture, which, commencing in the east of Asia, was propagated slowly and at distant periods westward. It obtained firm root in France during the reign of Henry IV., after great resistance on the part of the people, whose prejudices against the application of land to this purpose excited frequent rebellions. The unsuccessful attempt of James I. to establish it in England is not accounted for; but the times which succeeded were unfavourable to the introduction of new arts and inventions. The manufacture of silk goods was introduced into this country in the fifteenth century, and received a great stimulus by the revocation of the edict of Nantes in 1685. By this intolerant and disgraceful measure Louis XIV. drove thousands of his most industrious subjects to seek an asylum in foreign countries; of whom it is supposed not less than 50,000 emigrated to England. From this period the manufacture of silk goods became an important branch of trade in England. The common and even still existing prejudice, that our climate is unfitted for the growth of the tree, and the production of the worm, would probably be still more inveterate in former times. The acknowledged fact that England is much colder than the south of France or Italy, would naturally induce the idea that it was unsuitable both to the tree and the worms. Individuals among our countrymen have, however, constantly asserted the contrary, and numerous insulated experiments have been brought forward in support of their opinion. Miss Croft of York, in 1792, sent to the Society of Arts a specimen of silk produced by worms fed entirely upon lettuce leaves. We are not told, however, whether proper trials were made by subsequent experiments to prove its quality; and we have already observed that such silk, for purposes of manufacture, is perfectly useless, even in Italy. Yet we know it to be the opinion of men now perfectly conversant with the subject, that the various experiments and trials that have been hitherto made would long ago have succeeded, had we been fully informed on *all* the requisite points connected with the management of the tree, the worm, and its produce the cocoon. Our experimentalists have all laboured under one difficulty,—they were ignorant of the reeling process; and this probably arose from their experiments having been conducted on too small a scale to render it necessary to import or require the skill of winding the silk from the cocoon. This difficulty has at length been overcome by the exertions of Mr. Heathcoat, at whose establishment in Devonshire the improved method of reeling is now carried on with complete success.

7601. *The recent attempt to establish the culture of the silkworm in Britain* appears to have completely failed for the present. After collecting a great quantity of mulberry trees, and establishing considerable plantations in Devonshire and near Windsor in England, and in the vicinity of Cork in Ireland, the company in 1828 gave up the whole, without, in our opinion, having given the attempt a fair trial. As the mulberry will produce abundance of leaves as far north as Stockholm, and as the worms have to be hatched and brought forth in artificial heat even in France, there cannot be a doubt as to the success of this branch of culture in any part of the British islands. Whether it would pay is a different thing; we by no means think it would, even in Ireland.

7602. *This common honey bee* (*Apis mellifica L.*) inhabits Europe in hollow trees, but is chiefly kept in hives, being domesticated every where. Perhaps more has been written on the economy of this insect than on any other animal employed in agriculture, and certainly to very little purpose. After all that has been done in England, France, and Italy, the bee is still more successfully cultivated, and finer honey produced, in Poland, by persons who never saw a book on the subject, or heard of the mode of depriving bees of their honey without taking their lives. Much as has been written in France and England on this last part of the subject, it is still found the best mode to destroy the hive in taking the honey. Unanswerable reasons for this practice are given by La Grenée, a French apiarian, which are elsewhere quoted by us at length (*Encyc. of Gard. art. Bees*), and

allowed to be conclusive as to profit even by Huish. The honey produced by any hive or apiary depends much more on the season, and the quantity and kind of flowers with which the neighbourhood abounds, than on the form of the hive or artificial management. Viewing the subject in this light, we shall avoid noticing the mode of operating with glass, storying, cellular, or other curious hives of recent invention, and treat only of the simplest methods. The author we shall follow is Howison.

7603. *The apiary*, or place where the bee-hives are placed, should in very warm situations be made to face the east, and in colder districts the south-east. It should be well protected from high winds, which not only prevent the bees from leaving the hive in quest of honey, but they also surprise them in the fields, and often kill them by dashing them against the trees and rocks or into rivers. The hives in an apiary should always be placed in a right line; but should the number of the hives be great, and the situation not capacious enough to admit of their being placed longitudinally, it is more advisable to place them over one another on shelves (*fig. 417.*) than in double rows on the ground. A bee, on leaving the hive, generally forms an angle of about forty-five with the horizon; the elevation of the hive should therefore be about



two feet from the ground, in order to protect it from humidity. The greater the elevation of the hive, the longer is the flight of the swarm; and when they are at a certain point of elevation, the swarms are lost for ever to the proprietor. If the hives are to be placed in a double row, the hinder ones should alternate with, and be placed at such a distance from, the front ones, that when the bees take their flight no obstruction is offered to their ascent. Huish recommends placing every hive upon a single pedestal, and at two or three feet distance from each other. By this means, when any thing happens to one hive, the others are less likely to be disturbed than when placed on a shelf in a bee-house; and the hive may be chained down and locked. (*fig. 960.*) It is usual to have three or four legs or supports to the bee-boards; but those who have tried one will never resort to more, as one is a much better protection from vermin and insects. The space in front of the apiary should be kept clear of high plants for two or three yards.

7604. *The variety of bees* employed is a matter of some consequence. To the common observer all working bees, as to external appearance, are nearly the same; but to those who examine them with attention, the difference in size is very distinguishable; and they are, in their vicious and gentle, indolent and active natures, essentially different. Of the stock which Howison had in 1810, it required 250 to weigh an ounce; but they were so vicious and lazy that he changed it for a smaller variety, which possesses much better dispositions, and of which it requires 296, on an average, to weigh an ounce. Whether size and disposition are invariably connected, he has not yet had sufficient experience to determine.

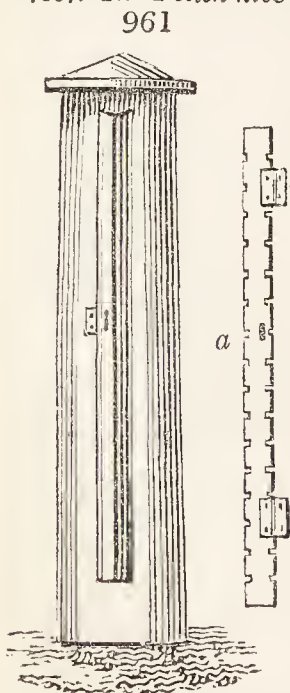
7605. *The best material and form* for hives is a straw thimble or flower-pot placed in an inverted position. Hives made of straw, as now in use, have a great advantage over those made of wood and other materials, from the effectual defence they afford against the extremes of heat in summer and cold in winter.

7606. *The size of hives* should correspond as nearly as possible with that of the swarms. This has not had that attention paid to it which the subject demands, as much of the success in the management of the bees depends on that circumstance. From blind instinct bees endeavour to fill with combs whatever hive they are put into, before they begin to gather honey. Owing to this, when the hive is too large for its inhabitants, the time for collecting their winter store is spent in unprofitable labour; and starvation is the consequence. This evil also extends to occasioning late swarming the next summer; it being long before the hive becomes so filled with young bees as to produce a necessity for emigration, from which cause the season is too far advanced for the young colonies to procure a winter stock. A full-sized straw hive will hold three pecks; a small-sized from one and a half to two pecks.

7607. *The Polish hive* (*Pasieka Pol.*, *fig. 961.*) appears to us to be the second in merits to that described, and perhaps it may deserve the preference, if the mode of using it were generally known. It is simply the trunk of a tree, of a foot or fourteen inches in diameter, and about nine feet long. It is scooped out (boring in this country would be better) for about six feet from one end, so as to form a hollow cylinder of that length, and of six or eight inches diameter within. Part of the circumference of this cylinder is cut out during the greater part of its length, about four inches wide, and a slip of wood is made to fit the opening. On the sides of this slip or segment (*a*) notches are made every two or three inches, of sufficient size to allow a single bee to pass. This slip may be furnished with hinges, and with a lock and key; but in Poland it is merely fastened in by a wedge. All that is wanting to complete the hive is a cover at top to throw off the rain; and then it requires only to be placed upright like a strong post in the garden, so as the bottom of the hollow cylinder may be not nearer the ground than two feet, and the opening slip look to the south. When a swarm is to be put in, the tree, with the door or slip opened, is placed obliquely over it; when the bees enter the door is closed, and the holes stopped with clay till the hive is planted or placed upright. When honey is wanted, the door is opened during the finest part of a warm day, when most of the bees are out; its entire state is seen from top to bottom, and the operator, with a segar in his mouth, or with a lighted rag, to keep off the bees from his hands, cuts out with a crooked knife as much comb as he thinks fit. In this way fresh honey is obtained during the summer, the bees are never cramped for room, nor does it become necessary to kill them. The old comb, however, is annually cut out, to prevent or lessen the tendency to swarming, which, notwithstanding this and the size of their dwelling, they generally do once a year; for the laws of nature are not to be changed. Though it be a fact that a small swarm of bees will not do well in a large hive; yet, if the hive extend in length and not in breadth, it is admitted both by Huber and Huish that they will thrive in it. "If too great a diameter," says Huber, "be

not given to the abode of the bee, it may without danger be increased in the elevation; their success in the hollow trees, their natural domicile, incontestably proves the truth of this assertion."

7608. *The feeding of bees* is generally deferred till winter or spring; but this is a most erroneous practice. Hives should be examined in the course of the month of September, or about the time of killing the drones; and if a large hive does not weigh thirty pounds, it will be necessary to allow it half a pound of honey, or the same quantity of soft sugar made into syrup, for every pound that is deficient of that weight; and in like proportion to smaller hives. This work must not be delayed, that time may be given for the bees to make the deposit in their empty cells before they are rendered torpid by the cold. Sugar simply dissolved in water (which is a common practice), and sugar boiled with water into a syrup, form compounds very differently suited for the winter store of bees. When the former is wanted for their immediate nourishment, as in spring, it will answer equally as a syrup; but if to be laid up as store, the heat of the hive quickly evaporating the water, leaves the sugar in dry crystals, not to be acted upon by the trunks



of the bees. Hives may be killed with hunger while some pounds' weight of sugar remain in this state in their cells. The boiling of sugar into syrup forms a closer combination with the water, by which it is prevented from flying off; and a consistence resembling that of honey retained. Howison has had frequent experience of hives, not containing a pound of honey, preserved in perfect health through the winter with sugar so prepared, when given in proper time and in sufficient quantity.

7609. *To protect hives from the cold*, they are covered with straw or rushes, about the end of September, or later, according to the climate and season. This is an essential business, as well covered hives always prosper better the following season than such as have not been covered. In October, the aperture at which the bees enter should generally be narrowed, so as only one bee may pass at a time. Indeed, as a very small portion of air is necessary for bees in their torpid state, it were better, during severe frosts, to be entirely shut up, as numbers of them are often lost from being enticed to quit the hive by the sunshine of a winter day. It will, however, be proper at times to remove, by a crooked wire, or similar instrument, the dead bees and other filth, which the living at this season are unable to perform of themselves. To hives, whose stock of honey was sufficient for their maintenance, or those to which a proper quantity of sugar had been given for that purpose, no further attention will be necessary until the breeding season arrives. This, in warm situations, generally takes place about the beginning of May; and in cold, about a month after. The young bees, for a short time previous to their leaving their cells, and some after, require being fed with the same regularity that young birds are by their parents; and if the store in the hive be exhausted, and the weather such as not to admit of the working bees going abroad to collect food in sufficient quantity for themselves and their brood, the powerful principle of affection for their young compels them to part with what is not enough for their support, at the expense of their own lives. To prevent such accidents, it is advisable, if during the breeding season it rain for two successive days, to feed all the bees indiscriminately, as it would be difficult to ascertain those only who require it.

7610. *The swarming of bees* generally commences in June, in some seasons earlier, and in cold climates or seasons later. The first swarming is so long preceded by the appearance of drones, and hanging out of working bees, that if the time of their leaving the hive is not observed, it must be owing to want of care. The signs of the second are, however, more equivocal, the most certain being that of the queen, a day or two before swarming, at intervals of a few minutes, giving out a sound a good deal resembling that of a cricket. It frequently happens that the swarm will leave the old hive, and return again several times, which is always owing to the queen not having accompanied them, or from having dropped on the ground, being too young to fly to a distance. Gooseberry, currant, or other low bushes, should be planted at a short distance from the hives, for the bees to swarm upon, otherwise they are apt to fly away; by attending to this, Howison has not lost a swarm by straying for several years. When a hive yields more than two swarms, these should uniformly be joined to others that are weak, as from the lateness of the season, and deficiency in number, they will otherwise perish. This junction is easily formed, by inverting at night the hive in which they are, and placing over it the one you intend them to enter. They soon ascend, and apparently with no opposition from the former possessors. Should the weather, for some days after swarming, be unfavourable for the bees going out, they must be fed with care until it clears up, otherwise the young swarm will run a great risk of dying.

7611. *The honey may be taken* from hives of the common construction by three modes, partial deprivation, total deprivation, and suffocation.

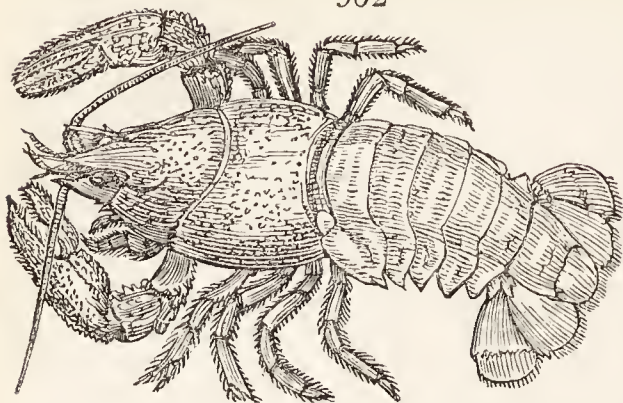
7612. *Partial deprivation* is performed about the beginning of September. Having ascertained the weight of the hive, and consequently the quantity of honeycomb which is to be extracted, begin the operation as soon as evening sets in, by inverting the full hive, and placing an empty one over it; particular care must be taken that the two hives are of the same diameter, for if they differ in their dimensions it will not be possible to effect the driving of the bees. The hives being placed on each other, a sheet or large table-cloth must be tied round them at their point of junction, in order to prevent the bees from molesting the operator. The hives being thus arranged, beat the sides gently with a stick or the hand, but particular caution must be used to beat it on those parts to which the combs are attached, and which will be found parallel with the entrance of the hive. The ascent of the bees into the upper hive will be known by a loud humming noise, indicative of the pleasure in finding an asylum from their enemy; in a few minutes the whole community will have ascended, and the hive with the bees in it may be placed upon the pedestal from which the full hive was removed. The hive from which the bees have been driven must then be taken into the house, and the operation of cutting out the honeycomb commenced. Having extracted the requisite quantity of comb, this opportunity must be embraced of inspecting the hive, and of cleaning it from any noxious matter. In cutting the combs, however, particular attention should be paid not to cut into two or three combs at once, but having commenced the cutting of one, to pursue it to the top of the hive; and this caution is necessary for two reasons. If you begin the cutting of two or three combs at one time, were you to extract the whole of them, you would perhaps take too much; and secondly, to stop in the middle of a comb would be attended with very pernicious consequences, as the honey would drop from the cells which have been cut in two, and then the bees, on being returned to their native hive, might be drowned in their own sweets. The bees also, in their return to their natural domicile, being still under the impression of fear, would not give so much attention to the honey which flows from the divided cells; and as it would fall on the board, and from that on the ground, the bees belonging to the other hives would immediately scent the wasted treasure, and a general attack on the deprived hive might be dreaded. The deprivation of the honeycomb being effected, the hive may be returned to its former position, and reversing the hive which contains the bees, and placing the deprived hive over it, they may be left in that situation till the morning, when the bees will be found to have taken possession of their native hive, and, if the season proves fine, may replenish what they have lost. (*Huish's Treatise on Bees.*)

7613. *Total deprivation* is effected in the same manner, but earlier in the season, immediately after the first swarm; and the bees, instead of being returned to a remnant of honey in their old hive, remain in the new empty one: which they will sometimes, though rarely, fill with comb. By this mode, it is to be observed, very little honey is obtained, the bees in June and July being occupied chiefly in breeding, and one, if not two, swarms are lost.

7614. *Suffocation* is performed when the season of flowers begins to decline, and generally in October. The smoke of paper, or linen rag soaked or smeared with melted sulphur, is introduced to the hive by placing it in a hole in the ground, where a few shreds of these articles are undergoing a smothering combustion; or the full hive may be placed on an empty one, inverted as in partial deprivation, and the sulphureous smoke introduced by a fumigating bellows, &c. The bees will fall from the upper to the lower hive in a few minutes, when they may be removed and buried, to prevent resuscitation. Such a death seems one of the easiest, both to the insects themselves, and to human feelings. Indeed, the mere deprivation of life to animals, not endowed with sentiment or reflection, is reduced to the precise pain of the moment, without reference to the past or the future; and as each pulsation of this pain increases in effect on the one hand, so, on the other, the susceptibility of feeling it diminishes. Civilised man is the only animal to whom death has terrors, and hence the origin of that false humanity, which condemns the killing of bees in order to obtain their honey; but which might, with as much justice, be applied to the destruction of almost any other animal used in domestic economy, as fowls, game, fish, cattle, &c.

7615. *On the produce and profit* of bees much has been said by the patriotic apiarists. Both, however are extremely uncertain; and as to the profit, it can never be great, while there is the competition of all Europe to contend with as to honey and wax, and no great demand for swarms. Bees, however, are interesting creatures; are supported at almost no expense; and a hive or two is therefore very desirable in the garden of every farmer and cottager.

7616. *The craw or cray fish* (*Cáncer A'stacus L.*, fig. 962.), called sometimes the fresh water lobster, inhabits still rivers, and forms holes in the banks.



7617. *They are said to be nutritious* and of an excellent flavour, and are prepared in cooking like lobsters or shrimps. In former times they were celebrated for sundry medicinal virtues, but these seem to be now forgotten. The flavour of these animals, nevertheless, depends entirely on the nature of their food. Like all others of their tribe, they feed principally upon flesh. They might be advantageously cultivated in ponds and marshes, but should not be put into fish ponds, as they are detrimental to the fry. A breeding stock may frequently be purchased in Covent Garden market, or procured from any of the small rivers near London; they are also said to be plentiful near Alnwick in Northumberland.

7618. *The edible snail* (*Hélix pomàtia L.*, fig. 71. a), although a native of the Continent, has been long naturalised in some parts of England.

7619. *It is the largest species found in Europe.* The animal being fleshy, and not of an unpleasant flavour, has been used as food from early times. It owes its introduction into England to certain medicinal virtues, no less than to its repute on the Continent as an article of food; but the first of these properties has long since been forgotten, and no progress has yet been made in introducing it on our tables. It is not so abundant in Italy as the common garden snail (*H. horténsis L.*), which may be seen, exposed in cages, in the markets of Genoa and other cities. We have no certain information which of these species was held in repute among the Romans, who had their cochleària or stews, where snails were bred, and fattened upon bran and sodden lees of wine. The *H. pomàtia* is preserved near Vienna in large pits, covered with boards, and fed with cabbage leaves and other vegetables.

620. *The medicinal leech* (*Hirùdo medicinàlis L.*) grows to the length of two or three inches. The body is of a blackish-brown colour, marked on the back with six yellow spots, and edged with a yellow line on each side; but both the spots and the lines grow faint, and almost disappear at some seasons. The head is smaller than the tail, which fixes itself very firmly on any thing the creature pleases. It is viviparous, and produces but one young at a time, which is in the month of July. It is an inhabitant of clear running water; but in winter the leech resorts to deep water, and in severe weather retires to a great depth in the ground, leaving a small aperture to its subterranean habitation. It begins to make its appearance in March or April. Water alone is not the natural element of leeches, as it is supposed, but conjointly with ground or mud.

7621. *The usual food of the medicinal and trout leech* is derived from the suction of the spawn of fish; and leeches will not unfrequently be found adhering to the fish themselves: but frogs form the most considerable portion of their food; hence, the best leeches are found in waters much inhabited by these animals. The medicinal and trout leech do not, like the horse leech, take any *solid* food; nor have they the like propensity to destroy their own or any other species of the genus; but these the horse-leech will not hesitate to devour. (*Newton's Journal*, vol. iv. p. 313.) If put into shallow clear ponds it will breed freely, and this is practised by some herbalists and apothecaries in the neighbourhood of London.

7622. *The use of leeches* for the purpose of local bleeding is very considerable. There are four principal importers of leeches in London alone, whose average imports are said to be 150,000 per month each; making a total of 600,000, or *seven millions two hundred thousand in one year*. On the Continent, where they are obtained at a much cheaper rate, the numbers employed are enormous. (*Ibid.*) The London market is partly supplied from the lakes of Cumberland, where the leeches are caught by women, who go into the water bare-legged, and after a few have fastened, they walk out and pick them off. A good many are also brought from Holland.

CHAP. XII.

Animals noxious to Agriculture.

7623. *Almost every animal may be injurious to the agriculturist in some way or other.* All the cultivated live stock will, if not excluded by fences, or prevented by herding, eat or tread down corn crops or other plants in culture. Those animals, as the dog and ferret, which assist him in deterring or in catching noxious animals which would prey on others, will themselves become depredators if not attended to; and even man, the only rational, and therefore the most valuable of agricultural servants, will prove, under certain circumstances, the greatest of all enemies to the agriculturist. We shall glance at the different animals more especially noxious in the order of their usual classification.

SECT. I. *Noxious Mammàlia.*

7624. *Of noxious Mammàlia* man, in a demoralised state, is the most injurious. The remedy is furnished by the law; — the preventive is good education, and civil and kind treatment by the master.

7625. *The fox* (*Cànís Vúlpes*) commits great ravages among lambs, poultry, geese, &c. To destroy it, the farmer must take a sheep's paunch and fasten it to a long stick; then rub his shoes well upon the paunch, that the fox may not scent his feet. He should then draw his paunch after him as a trail, a mile

or upwards, till he gets near some large tree; then leave the paunch and ascend into the tree with a gun; and as the night comes on, he may see the fox come after the scent of the trail, when he may shoot him. The trail should be drawn to the windward of the tree, if he can conveniently contrive so to do. — Or, set a steel-trap in the plain part of a large field, distant from paths and hedges; then open the trap, place it on the ground, cut out the exact shape thereof in a turf, and take out just so much earth to make room for it to stand, and then cover it again very neatly with the turf you cut out. As the joint of the turf will not close exactly, procure some mould of a mole-hill newly thrown up, and stick some grass on it, as if it grew there. Scatter some mould of the mole-hill very thin three different ways, at the distance of ten or twelve yards from the trap; let this mould be thrown on spots fifteen or sixteen inches square; and where the trap is placed, lay three or four small pieces of cheese; and then, with a sheep's paunch, draw a trail a mile or two long to each of these three places, and from thence to the trap, that the fox may approach one of the places first; for then he will advance to the trap more boldly; and thus you will be almost always sure of catching him. You must take care that your trap be left loose, that he may draw it to some hedge or covert, or he will otherwise bite off his leg, and so make his escape. — Or near the spot where the fox uses much to resort, fix a stick or pole, much in the same manner as for a woodcock. To explain this more exactly: tie a string to some pole set fast in the ground, and to this string fasten a small short stick, made thin on the upper side, with a notch at the lower end of it; then set another stick fast in the ground, with a nick under it; bend down the pole, and let the nicks or notches join in the slightest degree: then open the noose or string, and place it in the path or walk of the fox. By strewing flesh-meat, pieces of cheese, &c., as you pass along, you may entice the fox to take the same road.

7626. To shoot a fox, anoint the soles of the shoes with swine's fat, a little broiled; then go towards the wood, and, in returning, drop here and there a bit of swine's liver, roasted and dipped in honey, drawing after you a dead cat; and by these means he will be allured to follow you.

7627. The fox is sometimes taken with a hook, made of large wire, and turning on a swivel like the collar of a greyhound; it is usually hung so high from the ground, that he is compelled to leap to catch at it; and baited with fresh liver, cheese, &c., and if a trail be run with a sheep's paunch, as before directed, he will be drawn to the bait with the greatest ease.

7628. The pole-cat (*Felis Putorius L.*) may be caught and destroyed by a dead-fall, constructed in the following manner: — Take a square piece of wood, weighing forty or fifty pounds; bore a hole in the middle of the upper side, and set a crooked hook fast in it; then set four forked stakes fast in the ground, and lay two sticks across, on which sticks lay a long staff, to hold the dead-fall up to the crook; and under this crook put a short stick, and fasten a line to it: this line must reach down to the bridge below; and this bridge you must make about five or six inches broad. On both sides of this dead-fall place boards or pales, or edge it with close rods, and make it ten or twelve inches high. Let the entrance be no wider than the breadth of the dead-fall. — A pigeon house, surrounded with a wet ditch, will tend to preserve the pigeons; for beasts of prey naturally avoid water.

7629. The weasel, or *Foumart* (*Felis vulgaris L.*), though in some respects beneficial, in as much as when domesticated it destroys rats, mice, moles, and other noxious vermin, is nevertheless, in a wild state, a formidable foe to poultry and rabbits. Weasels may be destroyed by putting in their haunts small pieces of paste, consisting of pulverised sal ammoniac, mixed up with the white of an egg, wheaten flour, and honey. The strewing of rue round the place where hens nestle, is also said to drive away these depredators; as also will the smell of a burnt cat; as all animals are terrified at the burning of one of their own, or of a similar species.

7630. The badger (*Ursus Mèles L.*) destroys great numbers of young pigs, lambs, and poultry, every year. Some use a steel-trap, or a spring, such as foxes are taken in, to catch them. Others sink a pit-fall, five feet in depth and four in length, forming it narrow at top and bottom, and wider in the middle; they then cover it with small sticks and leaves, so that the badger may fall in when he comes on it. Foxes are sometimes taken in this manner. Others, again, pursue a badger to his hole, and dig him out: this is done by moonlight.

7631. The mole (*Talpa europæa*) is injurious by the subterraneous roads and hills of earth which it forms in grass lands. With regard to the removal of mole-hills various practices are in use; but the most effectual is that derived from the experience of a successful mole-catcher, and communicated to the public by Dr. Darwin, in his *Phytologia*. This man commenced his operations before sun-rising, when he carefully watched their situation; and frequently observing the motion of the earth above their walks, he struck a spade into the ground behind them, cut off their retreat, and then dug them up. As moles usually place their nests at a greater depth in the ground than their common habitation lies, and thus form an elevation or mole-hill, the next step is to destroy these nests by the spade; after which the frequented paths are to be distinguished from the bye-roads, for the purpose of setting subterraneous traps. This object may be effected by marking every new mole-hill with a slight pressure of the foot, and observing the next day whether a mole has passed over it, and destroyed such mark; and this operation should be repeated two or three mornings successively, but without making the pressure so deep as to alarm the animal, and occasion another passage to be opened. Now, the traps are to be set in frequented paths, and should be made of a hollow wooden semi-cylinder (*fig. 292.*), each end of which should be furnished with grooved rings, containing two nooses of horse-hair, that are loosely fastened in the centre by means of a peg, and are stretched above the surface of the ground by a bent stick or strong hoop. As soon as the mole passes half way through one of these nooses, and removes the central peg in its course, the hoop, or bent stick, rises in consequence of its elasticity, and of course strangles the mole. The simplicity of this mode of destroying mole-hills and moles recommends itself to general adoption, as those whose grounds are thus infested may easily extirpate them, by teaching this practice to their labourers.

7632. The domestic or Norway rat (*Mus Rattus L.*, *fig. 963.*) is now generally diffused throughout this

963



country, where it has almost extirpated the indigenous black rat. It is the most noxious quadruped we have, as it is destructive both to the live and dead stock of the farmer. The following methods for destroying it are preferable to all others, and are given in *Willick's Domestic Economy*, vol. iii. : — Fry a piece of sponge with salt butter in a pan; then compress it between two plates, and cut it into small pieces, and scatter them about the holes frequented by rats and mice. This preparation is devoured with avidity; it excites thirst in the animals, which should be gratified by exposing shallow vessels containing water. On drinking this fluid, after having swallowed the burnt sponge, it distends their stomach, and proves a fatal repast. — Or, a capacious cask of moderate height must be procured, and put

in the vicinity of places infested with rats. During the first week this vessel is only employed to allure the rats to visit the solid top of the cask, by means of boards or planks arranged in a sloping direction to the floor, which are every day strewed with oatmeal, or any other food equally grateful to their palate; and the principal part of which is exposed on the surface. After having thus been lulled into security, and accustomed to find a regular supply for their meals, a skin of parchment is substituted for the wooden top of the cask, and the former is cut for several inches, with transverse incisions through the centre, so as to yield on the smallest pressure. At the same time, a few gallons of water, to the depth of five or six inches, are poured into the empty cask. In the middle of this element a brick or stone is placed, so as to project one or two inches above the fluid; and that one rat may find on the former a place of refuge. These preparatory measures being taken, the boards as well as the top of the cask should now be furnished with proper bait, in order to induce them to repeat their visits. No sooner does one of these marauders plunge

through the section of the parchment into the vessel, than it retreats to the brick or stone, and commences its lamentations for relief. Nor are its whining notes uttered in vain; others soon follow, and share the same fate; when a dreadful conflict begins among them, to decide the possession of the dry asylum. Battles follow in rapid succession, attended with such loud and noisy shrieks, that all the rats in the neighbourhood hasten to the fatal spot, where they experience similar disasters. Thus hundreds may be caught by a stratagem, which might be greatly facilitated by exposing a living rat taken in a trap, or purchased from a professional rat-catcher.

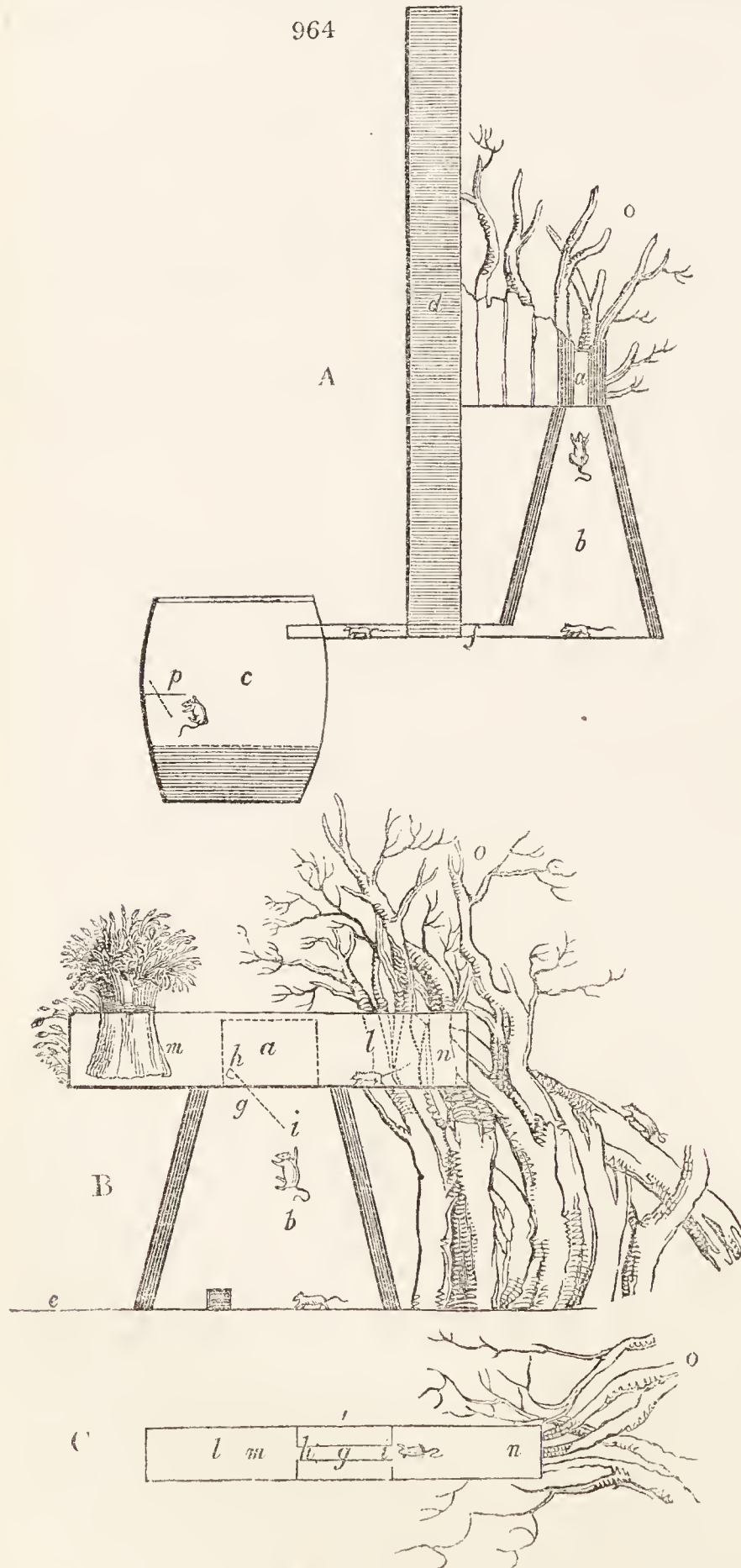
7633. *A successful mode of enticing rats* has been lately practised by Broad, a farmer at Thruxton in Herefordshire. He uses a bore trap, two feet long, eight inches wide, and nine inches deep, and little different in construction from the common one. His secret consists in scenting light-coloured malt, and also some wheat straws, with oil of caraways, and not setting the traps for a day or two till the rats have been accustomed to eat the malt without fear. (*F. Mag.* xiv. p. 431.)

7634. *Paul of Starston's rattery* is thus described by S. Taylor, Esq. in the *Gardener's Magazine*: —

7635. *This rattery* was invented by Mr. R. Paul of Starston, in Norfolk. He bestowed much labour and time to bring it to perfection; and, though living in a situation peculiarly favourable for encouraging the breed of rats, used to boast that he had completely subdued them. In fact, I have heard him say that he offered a reward to any one who would bring rats on his premises; and that having marked and turned off one

particular pair, he betted a wager that he should soon catch them both; which, in the course of a very few days, he did. He selected, as the site of his rattery, some outhouse where rats were known to frequent, and which he could lock up, and keep sacred to his own devices and operations. Here he fixed his trap, the construction of which will be best understood by referring to the accompanying sketches (*figs.* 964, 965.). This

964



The same letters refer to each of the figures.

A, End view of the trap, with the tub (section).

B, Longitudinal section of trap.

C, Birdseye view of longitudinal section of trap.

a, Doubting Castle.

b, Forlorn Hope.

c, Slough of Despond.

d, Partition wall.

e, Ground level.

f, Pipe of brick or tile.

g, Falling floor, or bottom of trap.

h, The weighted end of the fall, to bring it back into its place.

i, The end of the fall, that gives way under the rats.

l, Trough, or thoroughfare, in which the trap (a) is placed.

m, The feeding end of the trough.

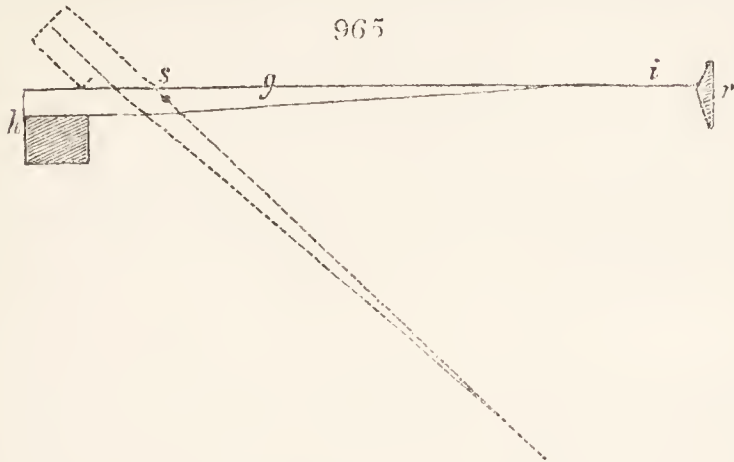
n, The end at which the rats enter.

o, Loose wood, to serve both as a cover and a road into the trap.

p, A slip of wood, to which the rats spring from the pipe f, and which gives way under them, and lets them into the water below.

spot he endeavoured to make as inviting and comfortable to the animals as possible; for which purpose he placed faggots, loose wood, and even straw, with an occasional wheat sheaf, on and about the trap. His plan was, to render the trough (*l*) a complete thoroughfare; for which purpose the trap or falling bottom (*g*) was, for several days, secured by a pin, and the end

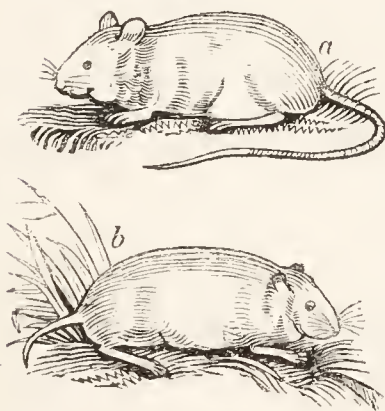
(*m*) used as a feeding place. After the rats had got accustomed to the spot, and passed the bridge with confidence, he took out the pin which secured it, and every rat that attempted to pass thereafter was taken prisoner. I should here observe, that great care is necessary in the construction of this part of the trap. It is not enough that the floor give way under the rat, and be merely brought back into its place again by the balance weight at the end of the bridge (*h*). One rat might be accidentally so caught, but you would not catch a second. They are, as is well known, remarkably cunning and suspicious in their dispositions; and are in the habit of trying the bridge with their forefeet, in order to ascertain its soundness, previously to adventuring the weight of their bodies thereon. It is obvious, therefore, that unless the bridge is sufficiently fastened to enable the rat to make this trial, the trap will be no trap to them; and yet the catch or fastening should not be so stiff but that it will suffer the bridge to give way under their weight when once upon it. I cannot show this catch in my sketches; they are so small, but (enlarging the scale) it is, when the bridge is viewed sideways, something like the annexed sketch (*fig. 965.*). *g* is the bridge or fall of wood tipped with thin sheet iron at the end (*i*), which works into the catch (*r*). This catch should be sufficiently rank to bear the trial already spoken of; and yet not so rank but that it suffer the bridge to fall when wanted (as shown by the dotted lines *n*). It is brought back by the weight (*h*), and moves on pivots at *s*.



7636. The beauty of Paul of Starston's trap is, that, when once set, and the catch (*r*) regulated to its proper pitch, it requires no further trouble. One is sufficient for the whole premises. The great object is, to give them time enough to get acquainted with it; for which purpose every thing should be done to attract them to the spot, and to make them feel themselves at home. A little pale malt, slightly tintured with oil of caraway, will prove to be the most inviting dish you can set before them; and it will be well to bear in mind, that no part of the trap, not even the straw or the wood by which it is surrounded, ought to be touched by the naked hand without first rubbing the skin with a portion of the oil of caraway. Do not scatter the malt upon the bridge (*g*), but spread it carelessly, as it were, about the feeding end of the trough (*m*). It will thus be in sight from the other end (*n*); and, to get it, the rats must pass the bridge (*g*); for it will be seen at *fig. 964. B*, that the entrance to the trap is now (by means of the wood piled up) at the end of the trough (*n*), although at first it had an entrance at each end, and was, as I have stated, a complete thoroughfare. Indeed, some have them on this plan still; having no particular feeding place, and trusting entirely to time and chance for what they may catch; having first taken pains to make the trap a *run*, and the place itself a harbour for rats. I do not know that it is requisite for me to add many more words. The drawings sufficiently explain the principle; and as to dimensions, those can be determined by the projector, and must, in some degree, depend on the size and convenience of the building to which the rattery is attached. The trap itself should not be above three or four inches wide, and twelve or fifteen inches long; in order to allow plenty of room for the fall of a large rat. "The forlorn hope" into which he dropped from

"doubting castle,"—for, you will observe, my friend had the *Pilgrim's Progress* in his eye when he was thus labouring to entrap sinners,—"the forlorn hope," I say, should be sufficiently deep to prevent the rat from making any attempt to reach the bottom of the trap (*g*); for which purpose it should be of a conical form, and perfectly smooth inside. Once in "the forlorn hope," therefore, he has no means of egress but by the pipe or drain (*f*), the length of which is immaterial, and which conducts to a tub or cistern of water called, not inaptly, "the slough of despond." Against the side of this tub is fixed a flap (*p*), upon which, as the only chance of escape, the rat jumps from the mouth of the pipe (*f*). It gives way under him, as shown by the dotted line, and he soon ends his career in "the slough of despond." It will be observed, that the operation of this trap is so silent, and yet so effectual, that hundreds may be caught in quick succession without any alarm being given to the remainder; for it appears that they continue but a very short time in "the forlorn hope," leaving it almost immediately for "the slough of despond;" their immersion in which (it being at such a distance from the trap) is unattended with any noise; whereas, had the water been immediately under the fall (*g*), each rat would have occasioned more or less of disturbance, and thus have intimidated many. Besides, the mere examination of the cistern, and taking out the captured, would have been a constant source of annoyance; whereas, in its present situation, it may be examined every day without in the least interfering with the trap. My friend had a mousetrap on the same principle, only on a smaller scale, and of lighter materials, which answered extremely well. The mice dropped through the trap into a little cistern of water beneath. (*Gard. Mag.* vol. vi. p. 585.)

7637. The long-tailed field mouse (*Mus sylvaticus* L., *fig. 966. a*), and the short-tailed field mouse (*b*),



are both rather larger than the common mouse. Of late years they have appeared in vast numbers in some parts of England, and caused incalculable damage to the agriculturist. In 1814, and the following year, the extensive plantations in Dean and New forests were nearly destroyed, over an extent of five hundred acres: the devastation was caused by these vermin attacking the five-year-old oak and chestnut plants, which they barked round at the bottom, and consequently destroyed. Ash, larch, fir, and holly plants were served in the same way; and, in many instances, the roots were gnawed through two or three inches below the surface. Lord Glenbervie observes, that this alarming havoc first became apparent in 1811, and increased to such a degree in the three following years, that the greatest alarm was felt by government for the safety of the growing timber on these extensive forests. Seven or eight different sorts of traps were set, a great variety of poisons tried, cats were brought in numbers and turned loose in those enclosures most infested, and crows, magpies, and owls were impressed into the service; but the number of these animals was so prodigious that no sensible diminution was perceived. At length a vast number of pits were dug; and as this method produced the most beneficial results,

we shall describe it. The pits were made from eighteen to twenty inches deep at the bottom, about two feet in length, and one foot and a half in width, and, at the top, only eighteen inches long and nine wide, or, indeed, as small as the earth could be got out of a hole of that depth; for the wider they are below, and the narrower above, the better they answer their purpose. They were made twenty yards asunder, or about twelve on an acre; or, where the mice were less numerous, thirty yards apart. By this method thirty thousand mice were caught in a short time, but a far greater number had been taken out of the holes, either alive or dead, by stoats, weasels, crows, and especially hawks. It was for a long time supposed that this damage had been caused by rabbits; and it is very probable that similar injuries are frequently attributed erroneously to these animals. Some years ago an extraordinary quantity of mice created similar devastation in Lord Bagot's extensive woods in Staffordshire, and in those of Lord Downes in Yorkshire (*Zool. Journal*, No. 4. p. 433.).

7638. The field mouse, in the forest of Dean, had become so destructive in 1813, that after trying traps, baits with poison, dogs, cats, &c. with little success, at last the plan of catching them by holes was hit upon. These holes were made from eighteen inches to two feet long, sixteen or eighteen inches deep, about the width of a spade at the top, fourteen or fifteen inches wide at the bottom, and three or four inches longer at the bottom than at the top. The object was to get the bottom of the hole three or four inches wider every way than the top, and the sides firm; otherwise the mice would run up the sides and get out again. The holes were made at twenty yards apart each way, over a surface of about 3200 acres: 30,000 mice were very soon caught, and the ground was freed from them for two or three years. As many as fifteen have been found in a hole in one night; when not taken out soon, they fell on and ate each other. These mice, we are informed, used not only to eat the acorns when newly planted, but to eat through the stems of trees seven and eight feet high, and one inch and a half in diameter; the part eaten through was the collar, or seat of life. (*Billington's Facts on Oaks and Trees*, &c. p. 43.)

SECT. II. *Birds injurious to Agriculture.*

7639. *Of birds*, the most decidedly injurious to man are the different hawks and kites, as most of the species attack and devour young poultry.

7640. *Various methods* have been proposed for remedying this evil, but they evince little acquaintance with the habits of these birds. Mr. Swainson recommends that the prevalent custom, of nailing such as have been killed against barn-doors or outhouses, be exchanged for the following: — In such parts of the country as are frequented by these birds, let two or three poles, ten or twelve feet high, be placed in the farmer's poultry yard, each pole being furnished with an iron spike six or eight inches long; pass this spike through the body of a dead hawk in the direction of the back-bone: it will thus be firmly secured, and give the bird an erect position; the wings being free will be moved by every breeze, and their unnatural motion will prove the best scarecrow either for ravenous or granivorous birds, more particularly the latter. Destruction by the gun is of course the most effectual.

7641. *Whether granivorous birds are more injurious than beneficial to the farmer*, is very questionable.

7642. *The crow, rook, raven, sparrow, magpie, and starling* are commonly called granivorous; yet this is an error, for they are all omnivorous, that is, feeding both upon animal and vegetable substances, and more particularly upon insects. We are annually told of large crops being either wholly or partially destroyed by insects of some sort or other; but we never hear that these injuries have been occasioned by birds. These complaints have certainly been more numerous of late years than formerly, and this is attributed by Mr. Swainson to the destruction of small birds (as waste lands are brought into cultivation); to the great diminution of rookeries; and to the foolish prejudice which the generality of farmers have taken up against these latter birds, which they destroy without mercy. In this instance we have been less wise than our ancestors, who protected and cultivated them, and by whom they were justly considered of the greatest benefit to mankind. Nature seems, indeed, to have pointed this out to us, for she has distributed the crow in all parts of the habitable world. Yet the farmer will enquire, "What good can these birds do me, when they come on my newly sown land, and root up the seed?" The answer is very short. The crows and rooks do not come for the express purpose of eating or destroying the seed, but for devouring the insects, snails, and grubs turned up by the plough or harrow; these are their favourite food, and while so occupied, the small quantity of seed they may eat or displace is returned to the farmer ten-fold by that saved from the insects. Wallis, in speaking of the destruction caused by the hedgechaffer or cockchaffer, says, that "whole meadows and corn-fields were destroyed by them;" and judiciously concludes by observing, "that the many rookeries with us is the reason why we have so few of these destructive insects." (*Hist. of Northumberland.*)

SECT. III. *Insects injurious to Agriculture.*

7643. *Insects, above all other animals*, are by far the most injurious to the agriculturist; not only from their numbers, but from their attacking the produce of the earth in all its stages of growth and maturity. We have already pointed out the advantage, not to say the necessity, of a certain knowledge being acquired respecting insects, by all persons engaged in agricultural pursuits. We shall now explain, in popular language, the different tribes or orders into which they are divided; the changes they undergo; and the injuries they produce to man, and the animals and vegetables which he cultivates. Numerous insects, much more destructive than those we shall enumerate, are found in other climates, but from which the British agriculturist has, happily, nothing to fear, and therefore need not be acquainted with. The reader will, however, find much valuable information respecting them concentrated in Kirby and Spence's *Introduction to Entomology*, vol. i.

SUBSECT. I. *Physiology of Insects.*

7644. *Insects are distinguished from worms* (*Vermes L.*) by always having feet in their perfect state, as the beetle, butterfly, &c. Worms crawl upon their bellies and have no feet, as the earth-worm, slug, snail, &c. The generality of insects have only six feet; but some few, generally called by this name, have a great many, as the wood-louse, centipede, &c.

7645. *Nearly all insects are oviparous*; that is, produced from an egg. These eggs are seldom found singly; they are small in size, and do not grow. The eggs of some species are hatched in a few days, while those of others remain during the winter, and the young do not come forth until the season at which the leaves of the plants upon which they feed begin to expand.

7646. *The second state of the insect is called the eruca*, or larva in systematic language, and is known to the vulgar by various names. Caterpillars are those larvæ which are exposed, and feed upon leaves and plants, as the caterpillar of the common cabbage butterfly (*fig. 971. a*). The larvæ of beetles usually live in the earth, in the trunks of trees, or in the substance upon which they feed; they are generally of a whitish colour, thick and clumsy in form, and are called grubs. The larva of the common cockchafer (*fig. 970. b*), and of the nut-beetles (*fig. 970. c*), are of this description; while the name of maggots is usually given to the larvæ of flies, bees, ants, &c., all of which live in the same confined state as those of beetles. It is in this stage of existence that insects are most voracious, and consequently most destructive to plants.

7647. *When the larva has attained to its full size*, it changes into the pupa or chrysalis state. This is done in different situations, according to the tribes to which they belong. The chrysalis of butterflies (*fig. 971. b, c*) are naked, and are either suspended or attached to trees, branches, walls, &c. Those of moths are either concealed in a case like the cocoon of the silkworm, or the caterpillar undergoes its change in the earth. The period in which insects remain in this state varies according to the species; but in most cases they are inactive and torpid.

7648. *The imago, or perfect insect*, is produced from the chrysalis, and is the only state in which all its parts and members are fully developed. The appearance and economy of perfect insects, in general, is totally different from those of the larvæ and pupæ, and it is only in its final stage of existence that the species can be ascertained. With the exception of such insects as form the A'ptera of Linnæus, all others are furnished with wings, either four or two in number. Some few exceptions, however, occur to this rule; the female of the glow-worm and of some few moths are apterous, while many beetles (although furnished with hard winged cases) are destitute of real wings.

7649. *The duration of insects* is extremely variable: the greatest proportion appear to be annual, emerging from the egg and passing through the three stages of their existence within the space of a year. But there are a great number of species, particularly among the beetles, which pass three, and even four, years in the caterpillar state; and instances are on record of beetles remaining in timber from ten to fifteen years. The greatest proportion of moths are biennial, passing the winter in the chrysalis state and elosing their existence in the succeeding summer. The transitory life of the *Ephéméra* is proverbial; the perfect insect indeed exists but for a day, and seems born only to continue its species; yet in the larva state it enjoys a life of one, two, or even three years.

SUBJECT. 2. *Arrangement or Classification of Insects.*

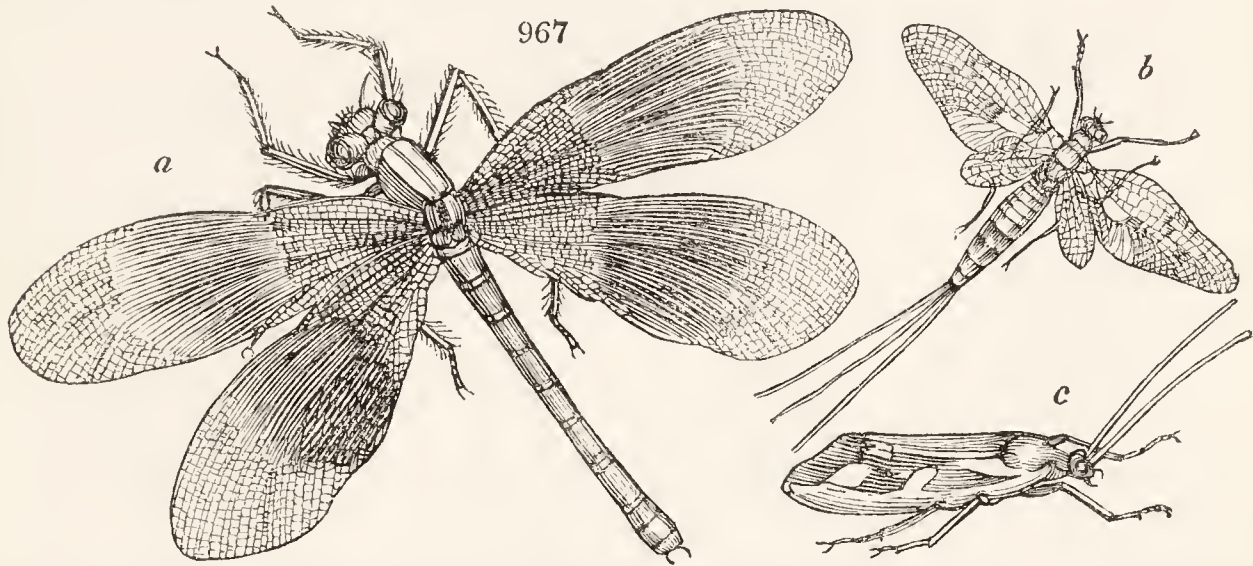
7650. *All insects*, as Maeleay observes, may be divided into two groups: 1. *Apterous insects*, having either no metamorphosis, or only that kind of it the tendency of which is confined to the increase of the number of feet: these, as their name implies, are destitute of wings. 2. *True insects*, or those whose metamorphosis has a tendency to give wings to the perfect or image state, but never more than six feet.

7651. *True insects* are again divisible into two primary groups; the first of these are organised for mastication in their perfect state, and the second are organised for suction alone. Each of these divisions, according to the system of Maeleay, contains five separate orders, the principal characters of which we shall endeavour to make intelligible in common language.

7652. *The Mandibulata, or masticating insects*, are furnished with jaws of a horny or membranaceous substance, infinitely diversified in their form and structure. They are divided into the following orders:—

1. *Trichóptera*. The wings are four, soft, and generally transparent; the upper pair slightly hairy, and the lower folded when at rest. The insects of this order are comparatively few. The caddy, or cadis worm, is the larva of the spring fly (*Phryganea*), and lives in the water, concealed within

a tube of its own construction. There are many species in this country, well known, in their perfect state, to all lovers of angling. *Phryganea rhombica* (fig. 967. c) may serve as an example of this order.



2. *Hymenóptera*. The wings are four, clear and transparent. The tarsus (or outer division of the foot) is composed of five joints, and the body is armed with a sting. The bee, the ant, and the wasp, are familiar examples.

3. *Coleóptera*. This well defined and most extensive order comprehends all insects known by the name of beetles. They have two wings, concealed beneath a pair of hard wing-cases, which meet close together in a straight line down the back. There are many tribes of these insects, which, both in their larva and perfect state, are extensively injurious to man.

4. *Orthóptera*. The true wings are but two, very large when expanded, and folded lengthways when at rest. They are covered, either partially or wholly, by two wing-cases of a thin, tough, and rather opaque substance, somewhat resembling parchment, and reticulated with small nerves. The leading characters of this order are exemplified in the *Blátta*, or cock-

roach; the pest of tropical countries, and frequently troublesome in our kitchens and larders.

5. *Neuróptera*. The wings, with very few exceptions, are four in number, clear, transparent, and reticulated with numerous areolets, or irregularly square divisions; the tail of the female is not armed with a sting. Few, if any, of these insects may be considered as injurious: some are, indeed, beneficial; as, from their predatory habits, they attack and devour a vast number of smaller insects. This is more particularly the habit of the green dragon-fly (*Agrion virgo*, fig. 967. a), which every one may see, during summer, hovering over ponds, and flying about like a hawk in search of its prey. The *Ephéméra*, or day-fly (*E. vulgata*, fig. 967. b), likewise belongs to this order; and, although not very numerous in this country, is so abundant on the Continent, that they are collected annually in barrows, and afford to the agriculturist a rich and valuable manure.

7653. *The Haustellata, or suction insects*, likewise contain five orders. Although apparently destitute of jaws, there is every reason to believe, from the observations of the celebrated Savigny, that the rudiments of the masticating organs exist in these insects, but that they are so slightly developed as to be totally useless, and only discoverable under a very strong magnifier. The suction insects in their larva state are mostly furnished with strong and well defined jaws, and feed voraciously upon animal and vegetable bodies; yet, from the perfect insect being supported by suction alone, it is obvious that in this state they can do no injury to the agriculturist. The orders into which they have been divided are these:—

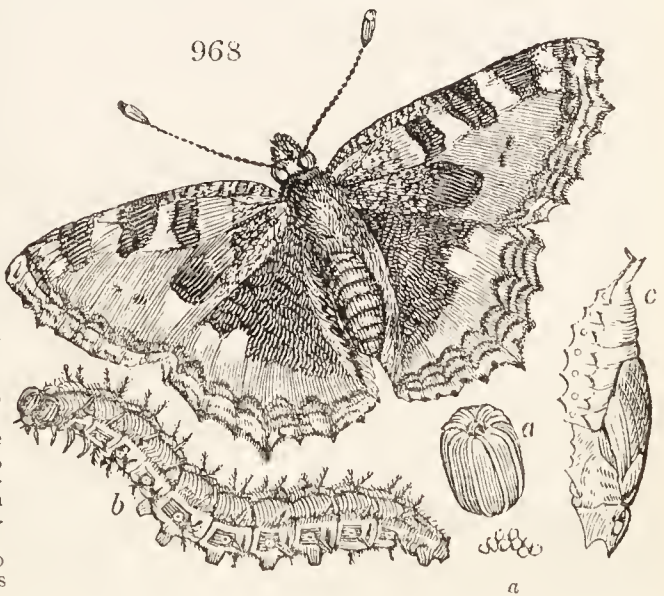
1. *Lepidóptera*. The wings are four, thin, membranaceous, and covered with a fine powdery substance, which, by the magnifying glass, is shown to consist of minute scales, lying one upon another, like those on fishes. The butterfly and moth tribes are familiar to every one, as well known examples of these insects, the larva of which are called caterpillars. The *Papilio urticae*, or small tortoise-shell butterfly (fig. 968.), will serve as a good example of the egg (a), larva (b), and pupa state (c) of most day-flying lepidopterous insects.

2. *Díptera*. The wings are two, clear and transparent, like those of the common house-fly. This order is very numerous, and contains many insects which are injurious to vegetables as larvæ, and troublesome to man in a winged state; as the gnat (*Culex*), whane-fly (*Tabanus*), crane-fly (*Tipula*), &c.

3. *Aptera*. Entomologists of the last century arranged all insects without wings under this order; but it is now restricted, by Latreille and Macleay, to such only as have a bivalve articulated sheath to their mouth or rostrum, and no wings, as in the case of the common flea.

4. *Hemíptera*. Insects of this order are furnished with two folded wings, covered by wing-cases, also crossing over each other, of a semi-corneous substance, and which are likewise useful as organs of flight. The tarsi are composed of three, two, or sometimes only of one joint, and the body is much flattened. The various insects commonly called field-bugs, which emit a strong and disagreeable smell when handled, are all arranged under this order.

5. *Homóptera*. These insects have a great resemblance to the last; but the body, instead of being depressed and flat, is



convex and thick; the wings also, instead of being folded over each other, are deflexed, and embrace the sides of the body. There are, comparatively, few homopterous insects in England; but the frog-hopper (*Cicada spumaria* L.) is a good example when in its perfect or winged state. The larva resides in a

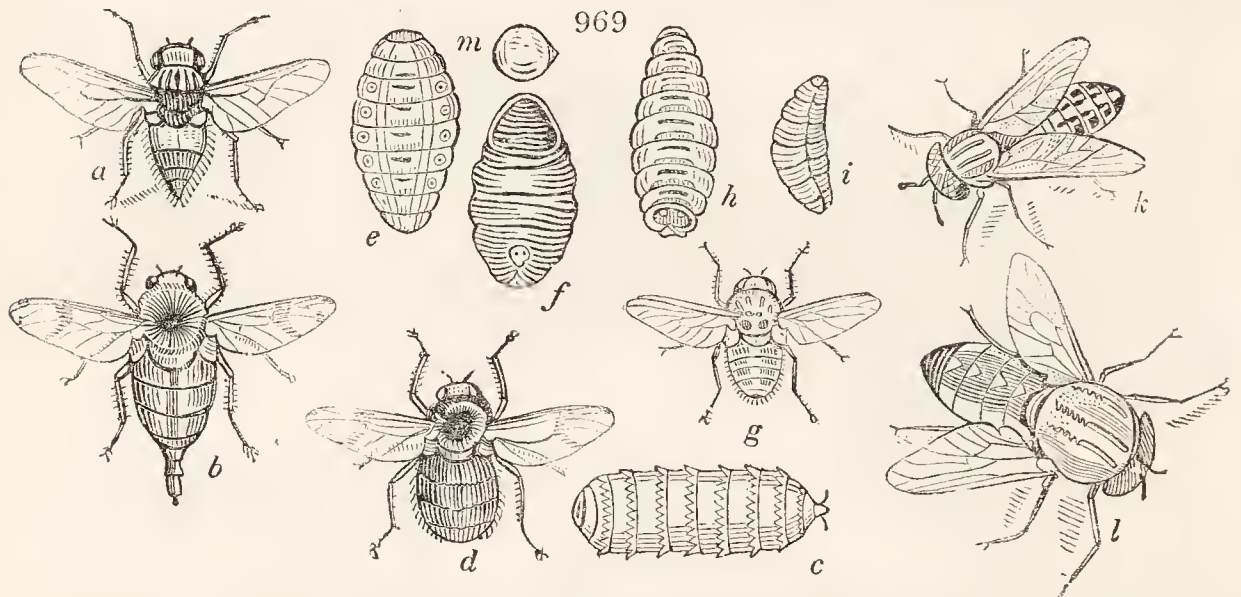
drop of froth of its own making, and is then commonly known as the cuckoo-spit insect; by feeding upon the sap it causes the leaves to curl up, and the growth of young plants is thus materially checked.

7654. *The different orders of insects* we have now enumerated are connected by others of an inferior extent, and which are called osculent orders. But as a description of these is not essential to our present purpose, and as they do not contain any decidedly injurious insects, we shall merely refer the reader to the *Hôræ Entomologicae* of Macleay, and the *Entomology* of Messrs. Kirby and Spence.

SUBJECT. 3. *Insects injurious to live Stock.*

7655. *All organised beings, whether animal or vegetable*, are subject to be attacked and destroyed by insects. Even man himself is not exempt from the dominion of these small but formidable creatures. For some wise but unknown purpose, there are peculiar species appropriated to receive their nourishment from man alone, and which cannot exist in any other situation. The remedies for these must be prescribed by the physician; but it is the business of the intelligent agriculturist to make himself acquainted with such as are injurious or hurtful to the animals and plants, upon which, the success of his operations mainly depends: for there are as yet no agricultural physicians, to whom the farmer can apply for advice or information when his labours are counteracted by insect devastators. We shall therefore briefly notice the domesticated animals and cultivated plants most subject to these injuries, pointing out the most efficient modes by which they may be checked.

7656. *The horse.* The principal foes to this noble animal are the horse-bee (*Æstrus equi*) and gad-fly (*E. hæmorrhoidalis*). The first deposits its eggs on such parts of the body as are liable to be licked by the tongue; and the animal, unconscious of what it is doing, thus conveys its enemy into its stomach; the young larvæ are there nourished, and become whitish rough maggots (*fig. 969. c*), which are known by



the name of bots. They attain their full size about the latter end of May, and are voided by the anus from that time until the end of June. On dropping to the ground, they find out some convenient retreat, where they change into a chrysalis; and in six or seven weeks the fly appears. The female (*b*) is distinguished from the male (*a*) by the lengthened shape of her body. The inside of the knee is chiefly selected for depositing her eggs, which will frequently amount to four or five hundred on one horse. The other species (*E. hæmorrhoidalis* L.) is still more troublesome; it deposits its eggs upon the lips, and causes excessive and distressing uneasiness to the animal. Mr. Bracy Clark, who has investigated the history of these insects with great ability, observes that in ordinary cases it is not improbable that they are beneficial to our cattle, by acting as perpetual stimuli or blisters; yet, when they exceed certain limits, they produce disease, and sometimes death. (Clark in *Linn. Trans.* vol. iii.) The prevention of bots belongs to the farmer, the cure to the veterinary surgeon. The first may be effected by watching the animal at the season when the female deposits her eggs (usually in August and September), and should the horse appear much agitated in its pasture, there will be good reason to suspect it has been attacked by the fly; the eggs may then be removed by the brush and currycomb, or by a pair of scissors. When the disease is certain, one of the best methods to destroy the insect is to fasten a bag net on the horse, for the purpose of catching the excrement, as well as the full-fed larvæ. By throwing the dung every morning into a deep pit, any larvæ that may be enclosed in it will thus be prevented from working their way to the surface when their last transformation is about to take place, and their death will cut off a numerous progeny. There are other dipterous insects which feed upon the blood both of horses and cattle; the most formidable of these are the horse-flies (*Tabani*, *k, l*); others, much smaller (*Stomoxys calcitrans*), assail him in every situation during summer, and dart their long probosces into his legs and belly. But none are more trying to him than the forest fly (*Hippobosca equina* L.), which runs sideways or backwards like a crab, and shelters itself in those parts least covered by hair: it may, however, be caught by the hand, when the animal is in his stall; but its substance is so hard, that it can only be destroyed by rolling it between the finger and thumb.

7657. *Horned cattle* are likewise subject to the attacks of a peculiar species of gad-fly (*Æ. bδvis*, *d, c, f*), which causes them great terror and distress. The larva (*e*) is smooth and fat: and the chrysalis (*f*) opens by a lid (*m*) when the insect (*d*) emerges from it. The herdsman may know when this insect appears among his flocks, by the agitation they exhibit; the whole herd, with their tails erect, or carried in some grotesque attitude, gallop about and utter loud lowings. When oxen are employed in agriculture, the attack of this fly is often attended with danger, as they become quite unmanageable, and, whether in harness or yoked to the plough, will run directly forward. Their harness at this season should therefore be so constructed as to be easily loosened. The eggs are deposited *within* the skin of the animal, and in a wound made by a tube resembling an auger, with which the female is provided. These flies only attack young and healthy subjects; but, independently of the terror they create, do not appear to occasion any material injury. The cattle of Hungary and the neighbouring countries, as also those of Abyssinia, are subject to more deadly enemies, which fortunately are unknown in England.

7658. *Sheep* are also infested by another species of gad-fly (*Æ. δvis* L., *g, h, i*), which deposits its eggs in the inner margin of their nostrils. The moment the fly touches this part of the sheep, they shake their heads, and strike the ground violently with their fore feet; at the same time, holding their noses close to the earth, they run away looking about them on every side, to see if the fly pursues: they will sometimes crowd together in a rut or dusty road with their noses close to the ground. The larvæ (*i*) are white, flat on one side and convex on the other; they inhabit the cavities of the maxillary sinuses, and crawl, when the animal is dead, into those of the horns and frontal sinuses; when full grown, they

fall through the nostrils, and change to the chrysalis (*h*), which produces the fly (*g*) in about two months. Swine, pigeons, and all kinds of poultry are subject to fleas, and lice of various kinds, but never to such a degree as to occasion death.

7659. *Fish*, in their young or fry state, are the food of the larvæ of water beetles (*Dytisci*). These insects are frequently seen in great numbers in ponds: they may be caught by a hand net (made of very small meshes), inserted beneath the insect, as he reposes (with his head downwards) on the surface, and then suddenly drawn upwards.

SUBJECT. 4. *Insects injurious to Vegetables.*

7660. *The ravages of insects upon plants* commence from the time that the seed is committed to the ground, and continue until the produce is gathered into the barn. These various injuries, in one shape or other, are annually experienced; and many of them, beyond all doubt, will hereafter increase to an alarming extent, if the great body of agriculturists persevere in their mistaken prejudice against crows, rooks, and other useful birds, which Providence has kindly given us, to keep the insect tribes within due limits. We have already noticed the destructive insects which are in a great degree peculiar to certain plants, as wheat, barley, &c. in a general way (Part III. Book VI.): we shall now enumerate those that infest the grains, clover, pastures, cabbages, and fruits, plantations, as well as those universal destroyers of *all* vegetables, the wire-worm, the plant lice, and the different species of crane-fly.

7661. *Wheat*, in every state, is subject to many insect depredators. Mr. Marsham describes a small grub (by some mistaken for the wire-worm), which eats into the young plant about an inch below its surface, devours the central part, and thus causes its immediate death. Out of fifty acres sown with wheat in 1802, ten had been destroyed in this way so early as October. At a later period this grain is attacked by a fly nearly related (according to Mr. Kirby to the *Mosillus arcuatus* of Latreille). It makes a lodgement in the heart of the principal stem just above the root, which stem it invariably destroys, giving the crop at first a most unpromising appearance; but it proved ultimately that the plant, instead of being injured, derived great benefit from this circumstance: for, the main stem perishing, the root (which was not hurt) threw out fresh shoots on every side, so as to yield a more abundant crop than in other fields where the insect had not been. When first observed in England, this insect caused great alarm among agriculturists, who thought it might prove the Hessian fly. When the wheat blossoms, it becomes exposed to the attack of a small orange-coloured gnat, which deposits its eggs in the centre of the flower; the larva or grub devours the pollen, and thus prevents the impregnation of the grain. The weevil, a small coleopterous insect (*Calandra granaria F.*), is extremely destructive to wheat when in the granary, where it feeds both in the larva and perfect state: against the first, we are acquainted with no remedy, as it lives in the grain; but as this is larger than the perfect beetle, the latter may be in a great measure collected by means of a sieve, large enough for the insect (but not the grain) to pass through: it is often found in such numbers, that they have been collected and destroyed by bushels. The same insect, or one very near it, often infests sea biscuit; and can only be killed by baking or heating the biscuits over again in an oven.

7662. *Rye* is subject to the attacks of a small fly (*Musca pumilionis*), which introduces its eggs into the heart of the shoots, and occasions a loss of from eight to fourteen plants in a square of two feet. No remedy has yet been proposed for this pest, which, if not extensive, may be checked by plucking the injured ears, and burning them.

7663. *Barley*, besides other insect foes, has one peculiar to itself, in the shape of a small moth (*Tinea hordei K.*). This fly deposits from twenty to thirty eggs on a single grain; when hatched, each of the larvæ disperses, and selecting a grain for itself, enters from without, and lies totally concealed: should these moths be observed in a granary, the injury may be stopped by carefully covering the grain, leaving a few handfuls exposed; upon these the moths will deposit their eggs, and by roasting or destroying this small quantity, the rest may be saved from infection.

7664. *Oats* are subject to few diseases; but, like all other grain, the plants are liable to be destroyed by that universal devastator the wire-worm, of which a more particular account will be found in treating of insects universally injurious to vegetables.

7665. *The diseases of peas* are mildew and blight, but these are only occasional; its insect enemies, however, are formidable. The principal of these is the plant louse (*Aphis*), one species of which is peculiar to this plant. In the year 1810, the crops of peas throughout the whole kingdom was so much destroyed by it, that the produce was not more than the quantity sown; and many farmers turned their swine into their pea-fields, not thinking them worth gathering. (*Kirby and Spence*, i. p. 177.) Beans are exposed to the same injury from another species of *Aphis* of a black colour, which begins at the top of the plant, and multiplies downwards. In both cases the most effectual remedy is to top the plants at an early period of the infection, and burn the parts so gathered; this plan is likewise advantageous, as it improves both the quality and quantity of the crop. The earlier peas are sown, the better chance they stand of escaping this pest; or if a small quantity of quick-lime is sprinkled upon them when they are a few inches high, experience has shown that the plants remain uninjured, while the *Aphis* is totally destroyed.

7666. *The diseases of beans* are the rust, honey-dew, and mildew. The insects which infest it, and their eradication, have already been noticed. (5256.)

7667. *Turnips* are subject to several peculiar diseases, and are the food of many noxious insects. On the first appearance of the cotyledon leaves, a whole host of little jumping beetles (*Haltica nemorum*), called by farmers the fly and blackjack, attack and devour them, so that the land is often obliged to be resown. An eminent agriculturist has calculated, that from this cause alone the loss sustained in the turnip crops of Devonshire in 1786 was not less than 100,000*l.* (*Young's Annals*, vii. p. 102.) Nearly as much damage is sometimes caused by a little weevil (*Curculio contractus Marsham*), which in the same manner pierces a hole in the cuticle; watering with lime water, &c. may serve to check both these evils.

7668. *The caterpillar* of a saw-fly (*Tenthredo L.*), entirely of a black colour, appears on the plants so soon as they have produced three or four rough leaves; these have sometimes occasioned considerable mischief, particularly in 1783, when many thousand acres were, on this account, ploughed up. These caterpillars are sought after with so much avidity by crows, rooks, and magpies, that those farmers, whose good sense have led them not to destroy, but rather to encourage, these useful birds, need not fear any great damage from this insect. To destroy it in the most effectual way, watering or sprinkling with lime has been strongly recommended.

7669. *The caterpillar* of the turnip butterfly (*Pieris napæ F.*) is also sometimes found on the turnip in great numbers: nearly fifty of the grub, which so much resembles the wire-worm, and which we have before alluded to (766.), have been found just below the leaves of a single bulb. These may, in a great mea-

sure, be enticed and destroyed, like the true wire-worm, which also does extensive injury to turnips. The small knob or tubercle, often observed on the roots, is inhabited by another kind of grub, probably the larva either of *Curculio contractus M.*, or *Rynchænus assimilis F.*, two small weevils. These, however, do not seem to affect the growth of the plant.

7670. *The vegetable diseases of the turnip* are the mildew (by some considered the effect of insects), distortion of the root (known principally by the name of fingers and toes), the anbury, the canker, and gangrene, or wasting from water and frost. None of these injurious diseases, as far as is known, admit either of prevention or cure: under favourable circumstances of soil, culture, climate, and weather, they seldom occur; and therefore all that the cultivator can do is to prepare and manure his land properly, and in the sowing season supply water when the weather is dry.

7671. *The hop* is liable to many external and internal diseases: by the first term we must be understood as alluding to injuries caused by insects, while those which belong to the vegetable are certainly internal. When the plants first emerge above the ground, they are infested by a small beetle, vulgarly called the flea. In a more advanced state the tops and branches are devoured by the hop *Aphis*, known to some by the name of the green fly, while at the same period the roots are subject to the attack of the caterpillar

of a singular species of moth, named by collectors the ghost. The vegetable diseases incident to the hop are, the honey-dew, the mould, the blight, and the fire-blast, all of which take place at different times, though mostly when the plant is full grown.

7672. *The hop insect, improperly called the flea*, has no other resemblance to that animal, than that it is small, and jumps. It is, on the contrary, a beetle (*Haltica concinna*), of a species closely allied to that which infects young turnips. In its perfect state it commits great havoc, by eating the tender shoots of the young plants. It has been said, that this insect abounds most in seasons when the nights are cold, and the days hot and dry. Others assert, that it is most frequent on plants in grounds that have been dunged the same year, on which account it has been recommended, that the manure used for covering the hills should be previously well mixed as before directed (6019.), and applied either over all the land, or only on the hills; but this and various other plans do not appear to have originated in a due knowledge of the subject. Nothing as yet appears known regarding the nature or habitation of this insect in its larva or grub state; and unless it is ascertained to live, during that period, in manure, the above plan will inevitably prove abortive. The deadly effects of lime upon insects, however small, has been extensively proved, and should be resorted to in all cases where the expected value of the crop will bear the expense of its application. Mr. Samuel Curtis has stated in the Horticultural Transactions (vol. 6. part 2. p. 124.) the very great advantages he has derived by applying pulverised quick-lime to fruit-trees; and there is no doubt that the same remedy would be equally successful if extended to the turnip and hop plants, so soon as the young leaves begin to appear, or on the first symptom of their being attacked by this insect.

7673. *The hop louse*, called by some the green or long-winged fly, is a species of Aphis peculiar to the plant; it makes its

7675. *Clover* is very subject to be injured by a very small weevil (*Aphion flavifemoratum* K.), which at all seasons feeds upon the seed of the purple clover, while another species of the same tribe (*A. flavipes*) devours that of the white or Dutch clover; the injury, unfortunately, cannot be known while the plants are growing, as they have then every appearance of being perfectly healthy. The young shoots of the purple clover are often devoured by the same little jumping beetles (*Haltica* F.) which attack both turnips and hops.

7676. *Pastures in general* are often destroyed to a very great extent by the larva or grub of the cockchafer (970. a), known in different parts of England by the following provincial names:—Brown tree-beetle, blind beetle, chafer, Jack horner, Jeffry cock, May bug, brown-clock, dor, and miller.

7677. *The ravages of the larvæ* are even exceeded by those of the perfect insect, which sometimes appears in this country in prodigious multitudes, and, like a flight of locusts, devour every green thing on the face of the earth. The eggs of this terrible devastator are white, and are deposited in the ground, where they soon change into a soft whitish grub with a red head, and about an inch and a half long (b). In this state it continues four years, during which time it commits most destructive ravages on the roots, not only of grass, but of all other plants and young trees. Whole acres of the richest pastures are thus rendered unproductive; all verdure is lost, and the turf will roll up almost with as much ease as if it had been cut with a spade. The whole of this injury being carried on under ground, admits neither of preventive nor palliative measures; but the destruction to be expected from the perfect insect may yet be prevented. If the dried and withered turf is now removed, the soil underneath will appear turned into a soft mould for about an inch in depth, like the bed of a garden; in this will be found the grubs, lying on their backs in a curved position, and vast quantities may be gathered and given to pigs and poultry. When full grown, the larvæ dig in the earth to the almost incredible depth of five or six feet, spin a smooth case, and then change into a chrysalis. In this inactive form they remain until the following spring.

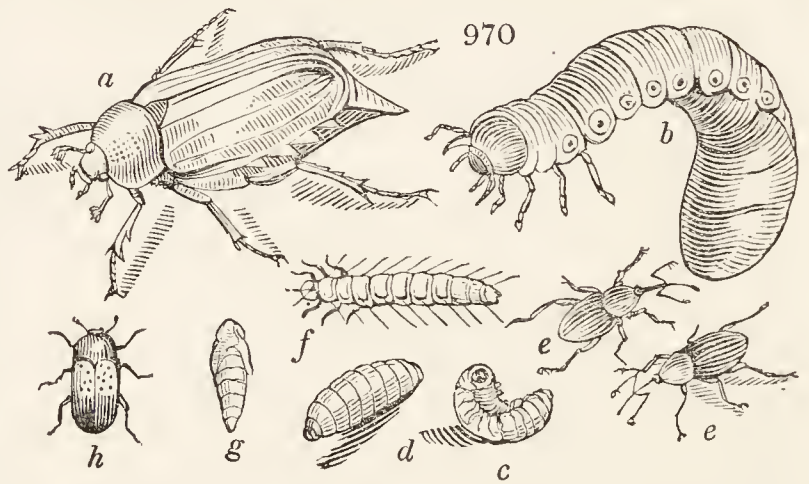
7678. *The perfect insect or beetle* then comes from the ground, and commences an immediate attack upon the leaves of all trees. Their numbers are sometimes so immense, that was not the following account fully authenticated, we should almost doubt its correctness:—In 1688, the cockchafers appeared on the hedges and trees in the county of Galway in clusters of thousands, clinging to each others' backs in the manner of bees when they swarm. During the day they remained quiet, but towards sunset the whole were in motion, and the humming noise of their wings sounded like distant drums. Their numbers were so prodigious, that for the space of three miles they darkened the air; and the noise they made in devouring the leaves was so loud, as to have been compared to the distant sawing of timber. In a very short time the leaves of all the trees for some miles were destroyed, leaving the whole country, in the middle of summer, as naked and desolate as it would have been in winter. Swine and poultry devoured them in vast quantities; they waited under the trees for the clusters

7679. *Cabbages and other esculent vegetables* are well known to be greatly injured by the caterpillars of two different kinds of white butterflies (fig. 971.), one of these (*Pieris brassicæ*, c) is much larger than the other: the caterpillar is pale yellow, with black spots (a); when full fed, it shelters itself on walls, pales, or trunks of trees, and changes into the chrysalis state (b), in which it still preserves the same cast of colouring: the perfect insect (c) appears early in spring, and continues until the end of summer. The other species of caterpillar is green (d); the chrysalis (e) is of the same colour; and the butterfly (f) is produced about the same time as the preceding. Various methods have been recommended to prevent the winged insect from depositing its eggs upon those plants which nature has given them the instinct to select; these are, however, ineffectual, and in many cases sufficiently ridiculous: handpicking the larva, and searching for the chrysalis, are the only plans we can recommend, either for these or the gooseberry and currant caterpillars.

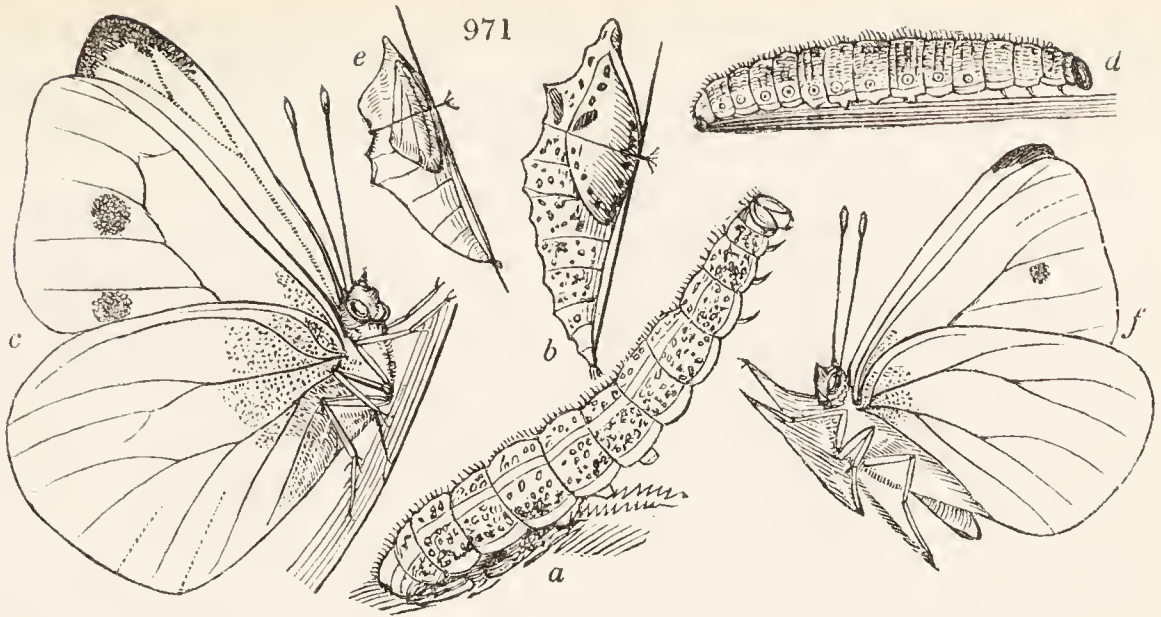
7680. *Fruit trees of all kinds*, and their produce, are attacked and devoured by a great variety of insects, an enumeration of which will be found in our *Encyclopædia of Gardening*. We shall, however, advert to those curious minute insects (*Thrips Phýsapis*, fig. 972. f, h) so often seen in flowers and blossoms during the spring, and which, in their natural size (f), appear like short black lines. Nearly all fruit trees are liable to considerable injury from different species of Coccus or cochineal insects. They are mostly so small

appearance towards the end of May, and during the two next months. These insects propagate so prodigiously, that whenever they have once made a settlement upon a hop plantation, they seem to have baffled every art of man, either to extirpate them, or even to check their increase. It is a vulgar error to suppose that they come or are carried away by any particular wind; or that mildly warm weather will affect their removal. It is true, that on such days the perfect insects are seen on the wing; but it is only to extend their destructive race to other plantations, and to establish new colonies. Sudden and violent showers of rain, or gusts of wind, causes the death of millions; and vast quantities are devoured by sparrows and other small birds; yet these are accidental and insufficient palliatives. It is, therefore, strongly recommended, that the process described by Curtis, of throwing pulverised lime by the instrument he used, be tried on hops infected by the Aphis; and we venture to predict that it would be attended with considerable success.

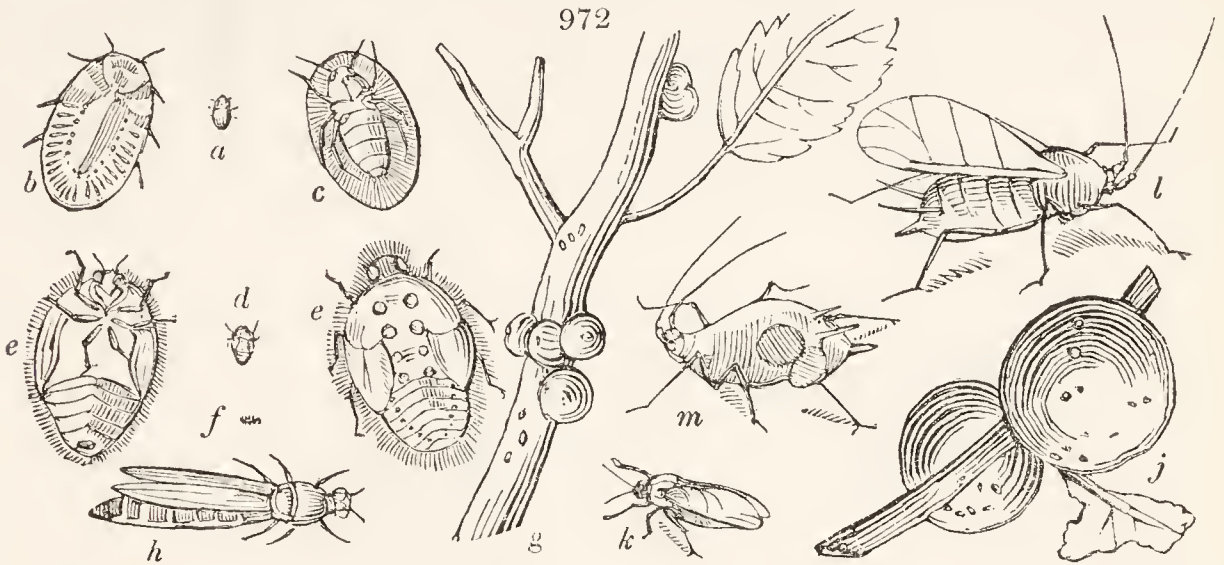
7674. *The ghost moth* (*Hephalus humuli* F.) deposits its eggs near the roots of the hop plant, upon which the larva or caterpillar feeds, sometimes doing them considerable injury. The best preventive is to destroy the moth, and this may be done by attracting it at dusk to a candle and lantern, carried by a boy over the grounds, who could knock down very many with his hat. The moth is of a tolerable size; and one sex is entirely white, so that it may be seen, even at night, with ease. It hovers over a small spot of ground, so that a good catcher of insects might clear the plantation in a few evenings. In 1826 the ghost moth appeared in many parts of Warwickshire, in very considerable numbers.



dropping, and became fat upon this unusual food: even the lower orders of the people, from these insects having eaten up the produce of the earth, adopted a mode of dressing them, and used them also as food. Towards the end of summer they are said to have suddenly disappeared; and we have no account of their having been seen in any considerable numbers the following year. (*Phil. Trans.* xix. p. 745. &c.) These grubs did so much injury about seventy years ago to a poor farmer near Norwich, that the court of that city, out of compassion, allowed him 25*l.*; the man and his servant declaring that they had gathered eighty bushels of these beetles. The best, and indeed the only effectual remedy for the destruction of the perfect insect, is to shake the trees or bushes at noon, when they are either asleep, or in a state of stupor, and then to sweep or gather them up. One person in this way has been known to capture a thousand in a day, which, on a moderate calculation, prevented no less than one hundred thousand eggs from being laid. Some judicious farmers plough the ground when they have reason to think it is infested by the grub, and this is generally indicated by the rooks attempting to reach them. They are also greedily devoured by crows, magpies, and jays, whose sole employment, for nearly three months in the spring of the year, is to search for insects of this sort; and the destruction they cause among them is above all calculation.

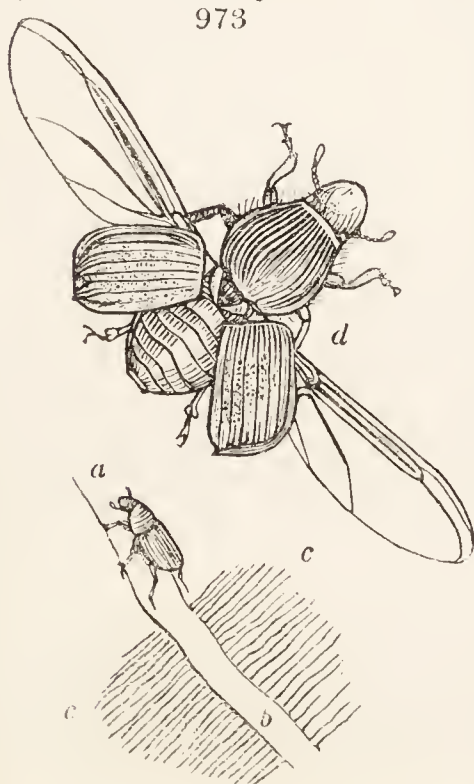


(fig. 972. a, d), that their form cannot be well distinguished without the aid of a magnifying glass ; many of them resemble small scales or scabs fixed on the bark and shoots. One is entirely of a brown colour (*Coccus persicorum* a) : when magnified (b) it somewhat resembles the tortoise beetle (*Cassida* L.), the legs and head being only discernible when the insect is turned on its back (c). Another (*C. fdl. quercus*,



d, e, e) does much injury to the oak ; while the *C. fagi* attacks the twigs of the beech (g), and causes small round excrescences to appear ; these are, however, very different from the gall apples of the oak (j), which are often found of a considerable size, and are produced by the *Cynips quercus folii* L. (k), or oak gall-fly, and always contain either the larva or imperfect insect. The weevils (*Curculionidae*) form an exceedingly numerous family, subsisting principally upon fruit, seed, and grain. One of the largest found in this country is the nut-weevil (*C. nucum*, fig. 970. e, e), the larvæ of which (c, d) are the maggots so frequently found in this fruit.

7681. The insects injurious to plantations are less numerous in this country than on the Continent, yet



we have two species whose devastations of late years have caused much alarm and extensive injury. The pine plantations in various parts of Britain have suffered from the great saw-fly (*Urocerus gigas* Lat.), the larva of which, feeding upon the heart of the tree, and boring it in all directions, soon destroys it. Another small insect of the beetle kind (*Scolytus destructor* F., fig. 973. a magnified) is equally deadly to the elm ; and from being more common, and propagating very rapidly, is more to be dreaded. The sudden destruction of a large proportion of the elms in St. James's and Hyde Parks has recently called the attention of government to this beetle ; and at the request of the noble rangers, Mr. Macleay undertook to investigate the evil : the result of his observations have been since published (*Edinb. Phil. Journal*, No. 21.). It appears that the female (a) may be found upon the trunk of the elm from March to September : she first penetrates through the bark, and then proceeds to form a passage between that and the wood, depositing her eggs during her progress on each side ; when these are exhausted, the parent dies, and is often found dead at the extremity of the passage (b) thus formed. When the eggs are hatched, the young larvæ immediately begin to feed by working nearly at right angles (c) from the path of the parent, each proceeding in a parallel direction and close to his neighbour : in this state they may be found in January. To stop this mischief as much as possible, Mr. Macleay recommends that the trees should be inspected twice a year : in summer, when the perfect insect is on the wing ; and again in winter, when infected trees should be cut down and burned, or subjected by fumigation to such a degree of heat as may destroy the larvæ ; or the bark may be covered with a mixture of tar and train oil, in March, to a certain height from the ground, applying this composition only to such trees as there are still hopes of preserving.

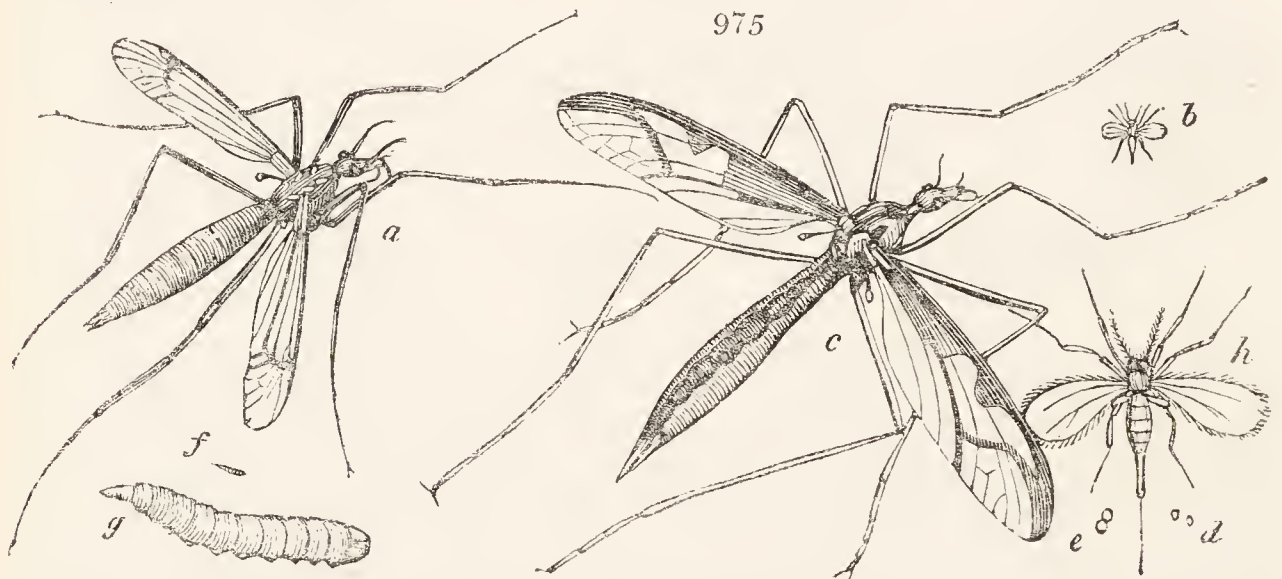
7682. *The A'phides or plant lice*, next to locusts, are the most universal devastators of the vegetable world: almost every plant has its peculiar species; their fecundity is so prodigious, that Reaumur has calculated that in five generations one A'phis may be the progenitor of 5,904,900,000 descendants; and it is supposed that in one year there may be twenty generations! Those which attack the different kinds of grain seldom multiply so fast as to be very injurious; but those peculiar to pulse increase rapidly, and take such possession, that the plants are greatly injured and frequently destroyed before the seeds are matured.

7683. *These insects are equally injurious in their winged (fig. 972. l magnified) and in their larva or apterous state (m magnified); they are a favourite food of sparrows and other birds, who destroy numbers: they are likewise exposed to other deadly and cruel enemies; one of these is a small hymenopterous insect, which deposits its egg in the body; it is there hatched, and feeds upon the intestines; in a short time the A'phis swells, becomes hard, and, from being green, changes to a dark red colour. The arful destroyer within, when he finds his victim dying, eats a hole through its belly, and fastens the A'phis, by that part, to a leaf or twig. When the parasite has thus devoured the inside, and is ready to emerge as a perfect insect, he opens a passage for himself by cutting out a round hole in the side, leaving the piece, like a door on its hinges, adhering to the body (m). But the most inveterate and destructive foe to the plant-lice is the lady-bird or lady-cow (Coccinella L., fig. 974. a), which, in its larva state (b), feeds entirely upon these insects; and the havoc made among them may be conceived, from the myriads upon myriads of these pretty little creatures which are usually seen in years when the plant-louse abounds; every one, probably, destroying tens of thousands of A'phides before he becomes a beetle. On this account the lady-bird is the greatest friend to the gardener and farmer; and could there be any method devised of increasing these useful insects at will, our hot-houses, gardens, fields, and hop plantations,*

would soon be cleared from the ravages of plant-lice. The larvæ of several bee-like flies (Syrphus F., c) are no less useful in this respect. Their form very much resembles that of the leech, having no apparent head. Some species are green, with a white stripe down the middle; others brown, variegated with darker shades. They are always found upon those plants most infected by A'phides, upon which they solely depend for nourishment; hence they become most beneficial, and should on no account be destroyed. As palliative measures, the application of powdered quick-lime may be resorted to; or the infected shoots may be topped off before the insects are greatly multiplied, repeating the same operation before the time that the winter stock of eggs are deposited. By the first pruning a very numerous present increase will be prevented; and by the second, the following year's breed may, in a great measure, be destroyed. (*Phil. Trans.* 41. p. 181.)

7684. *The wire-worm* is a name that has been given, without discrimination, to the larvæ or grubs of various insects, totally different from each other: hence it is, that much confusion and contradiction will be found respecting it in agricultural books. The true wire-worm is the grub of a small beetle (*E'later ségetis Marsham*), and it derives its name from its slender form and uncommon hardness. It lives in the larva state nearly five years; during which time it is supported by devouring the roots of wheat, rye, oats, and grass, which it attacks indiscriminately, and causes annually a large diminution of produce: it abounds chiefly in newly broken-up land, and is particularly destructive in gardens recently converted from pasture land. In the larva state it may be decoyed by offering it more tempting food; but no method has yet been devised for destroying the perfect insect.

7685. *The grub* is a general name for several larvæ of crane flies (*Tipuladæ*), called by the country people long-legs, or gaffer long-legs.



7686. *One of the most destructive among these insects to the roots of grass and grain is the Tipula oleracea. The larva is said, by some authors, merely to loosen the roots by burrowing among them; but others assert, that it likewise feeds upon the fibres. However this may be, the evil produced is evident; for in many parts of England it cuts off a large proportion of the wheat crops, especially if sown upon clover-lays. Reaumur informs us, that sometimes in France, particularly in marshy lands, the grass of whole districts has been so destroyed by it, as not to produce the food necessary for the sustenance of the cattle. No effectual remedy has yet been discovered for this evil; and Steckney observes, that the insect is not killed by lime, even when applied in much larger doses than usual.*

7687. *There are several other species of a large size, as the Tipula crocota (fig. 975. a), and Tipula rivosa (c), which, in a less degree, are also injurious to such lands as are moist and humid.*

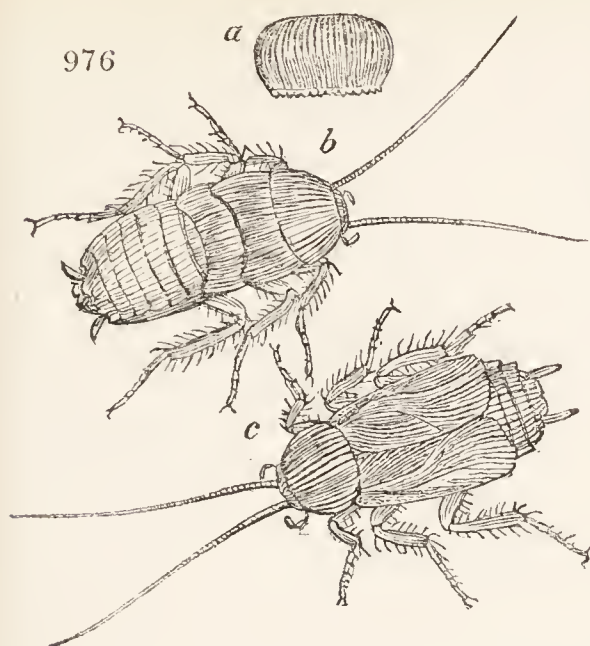
7688. *Another minute species is particularly destructive to corn, and is generally known as the wheat-fly (Tipula tritici, b): its history and economy has been ably investigated by Mr. Marsham and Mr. Kirby. The injury first appears in the ear, several of which, on being opened, will be found to contain an orange-coloured powder; in this are concealed very minute larvæ (f), which, on being magnified (g), are seen to be thick at one end, extending and contracting themselves at pleasure,*

and frequently jumping half an inch at one spring; they take their station in the longitudinal furrow of the grain, and by sucking its milky juice causes it to shrink up, and become what the farmers call *pungled*: the last sown wheat always appears the most infected. In the beginning of June the perfect insect (b) may be seen in innumerable multitudes, flying in the evening in all directions over the corn-fields; but during the day not one is to be perceived. The female lays her eggs (d e magnified) by means of a retractile tube, which encloses a very long and acute sting resembling a hair; but this can only be distinctly seen when the insect is magnified (h). The wheat-fly would soon become a formidable enemy to mankind, were not its race exposed to an inveterate foe, scarcely larger than themselves; this is the *Ichneumon Tipulae*, the female of which carefully searches out the grubs of the wheat-fly, and deposits in each one of her eggs: these are hatched, and ultimately the larva devours the body which gave it life. One *Ichneumon* will thus cause the death of many dozens, and prevent the future multiplication of thousands. The only palliative that has been recommended for stopping the progress of this insect has originated in Mr. Kirby; this consummate naturalist thinks much benefit would be derived by fumigating the corn with tobacco and sulphur, when the wind is in a favourable quarter: this must be done as soon as the ear begins to shoot from the leafy stalk. (*Linn. Trans.*)

SUBJECT. 5. *Insects injurious to Food, Clothing, &c.*

7689. *The manufactured produce of our fields and gardens, whether as food or clothing, is still exposed to the ravages of other tribes of insects, which take up their residence in our dwellings, and on every thing about us. Fortunately, however, these domestic enemies are much less numerous and hurtful in this country than in the tropical regions of America, India, and Africa, where their devastation is almost incredible. Amongst the few that are indigenous, or that have been naturalised in Britain, the principal are the cock-roach, the house-cricket, and the bacon-grub.*

7690. *The cock-roach*, called by some the black



beetle (*Blatta orientalis*, fig. 976. c), was originally imported from India, but is now naturalised in every temperate part of Europe. Like most of its tribe, it shuns the light, both natural and artificial. In the London houses, particularly in the rooms on the ground-floor, it is very abundant, and indiscriminately devours bread, meat, flour, and even clothes. As soon as light appears they all scamper off as fast as they can, and vanish in an instant. It is said to be killed by devouring red wafers. The young are contained in a singular horny case (a), which is divided into a number of transverse partitions or chambers; it is rather flattened, and quite smooth except one side, which is toothed. The larva and pupa (b) are both without wings, and generally larger than the perfect insect (c).

7691. *The house-cricket* (*Gryllus domesticus* L.) is sometimes as abundant in farm-houses as the cock-roach is in those of London and other large towns: both insects devour every kind of food, and are often found drowned in pans of water, milk, and other fluids; it is said they will even attack stockings, or linen hung out to dry. They require great warmth, and are therefore mostly found in kitchens and bakehouses. Another species is peculiar to pastures, which, in conjunction with the male cricket, feeds only upon roots: both these, however, are too local in this country to be very extensively injurious.

7692. *The bacon-grub* (*Dermestes lardarius* L.) is a great pest to the winter provisions of the farmer, devouring hams, bacon, and all sorts of dried meats. This is principally done when the insect is in its larva or grub state (fig. 970. f). When full fed it becomes a chrysalis (g), which ultimately changes into a small beetle (h) about a third of an inch long, of a dusky brown colour, with the upper half of the wing-cases whitish or ash-coloured, marked with black specks. The grub, from lying concealed in the meat, cannot be effectually removed; but by watching the time when the perfect insects appear, they may then be destroyed, and a recurrence of the evil in a great measure prevented.

7693. *Woollen clothing of every description, furs, &c.* are liable to be devoured by the larvæ or caterpillars of no less than five distinct species of small moths. Most of these enclose themselves in little tubular cases of a silky texture, and are so well disguised externally by fragments of the stuff they feed upon as often to escape immediate observation. The receipts for preventing these ravages are numerous, but few of them can be depended upon. As a preventive, pieces of Russia leather, or tobacco leaves, may be laid between the folds of garments (in drawers) which are not often used. If there is reason to fear the moths are in the house, these garments should be frequently opened, and aired by exposing them to the sun. When furs of any kind are laid by for the summer, they may either be sprinkled with snuff or camphor, and Russia leather or tobacco leaves put in the drawer or box. Should the moth actually have got into furs, the only way of checking the evil is to put them into an oven moderately heated, and by keeping them in this situation a quarter of an hour every grub will be effectually killed; the degree of heat may be ascertained, in the first instance, by putting in some common feathers, which should come out uninjured.

7694. *The principal insects injurious to the agriculturist* have now been enumerated: there are many others which feed upon cultivated vegetables and domestic stores, but in a less extensive degree. Let us not suppose, however, that these little animals have been created for our punishment or annoyance. We have but taken a view of one side of the picture; the other would show us innumerable benefits, either immediate or remote, which we derive from this race of beings. The silkworm, the honey-bee, and the cochineal insect must not be forgotten; and myriads of others are created, whose sole occupation during life appears to be that of devouring and keeping within due limits those tribes that are injurious and hurtful to man.

SUBJECT. 6. *Operations for subduing Insects.*

695. *The operations for destroying insects*, or counteracting their injurious effects, are various, and in most cases must be regulated according to the species. These we have already pointed out in treating upon the insects themselves, or of the particular plants upon which they feed. It only remains to offer such general rules as are more or less applicable to all destructive insects; these are of three kinds, preventives, palliatives, and efficient processes.

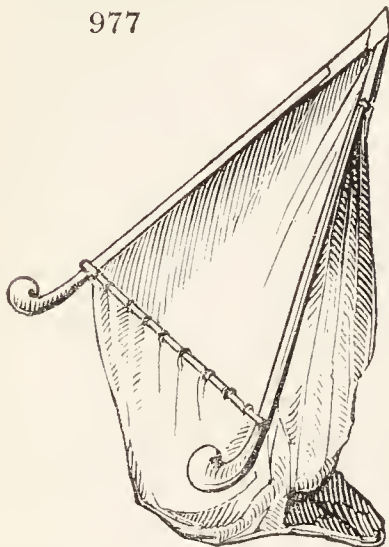
7696. *The preventive operations* are those of the best culture as relates to the choice of seed nor plant, soil, situation, treatment, and climate: the four first are under the control of man, and an attention to them will undoubtedly lessen the risk of injured crops; but as regards weather, neither his foresight nor care can avail any thing.

7697. *The palliative operations are numerous*; and such as are eminently successful may be considered as efficient; inasmuch as it rarely if ever happens that any insect can be exterminated, even from one district: its numbers may be diminished, but the species will still remain, although in such small numbers that its operations may escape notice. Most insects will be injured, and in part destroyed, by artificial bad weather, such as excessive waterings, stormy application of water with a syringe, and violent wind produced by shaking the tree or plant: many will thus be bruised, and others that are shaken to the ground can be destroyed. Insects may be further injured by watering the plants upon which they feed, either with tobacco or lime-water, or by scattering upon the leaves powdered quick-lime, soot, ashes, barley awns, &c. The smell of tar is particularly offensive to all insects, and the effects produced by the fumes of tobacco, sulphur, urine, &c. are well known. Hot water may be applied with much advantage. Water heated to 120 or 130 degrees will not injure plants whose leaves are fully expanded, and it may be increased to 200 for such as are without leaves.

7698. *Insects may be destroyed* in a much more effectual manner by enticement, or placing in their way other food as a trap. The late noble and generous Sir Joseph Banks has the merit of having recommended and made known this most efficient method. It simply consists in cutting slices of potatoes or turnips, sticking them upon skewers, and then burying them near the seeds sown: the vermin will collect upon them during night, and by examining them every morning, vast numbers may be destroyed; this plan has been very advantageously tried with the wire-worm, and no doubt would be equally beneficial in clearing all crops that are attacked by under-ground feeders. Mr. Kirby states, "that it was very successfully employed in 1813, by J. M. Rodwell, Esq. of Barham Hall, near Ipswich, one of the most skilful agriculturists in Suffolk, to preserve some of his wheat-fields from the ravages of a small grey slug, which threatened to demolish the plant. Having heard that turnips had been used with success to entice the slugs from wheat, he caused a sufficient quantity to dress eight acres to be got together; and then, the tops being divided and the apples sliced, he directed the pieces to be laid separately, dressing two stretches with them, and omitting two alternately, till the whole field of eight acres was gone over. On the fol-

lowing morning he employed two women to examine and free from the slugs (which they did into a measure) the tops and slices; and when cleared, they were laid upon those stetches that had been omitted the day before. It was observed invariably, that in the stetches dressed with the turnips, no slugs were to be found upon the wheat, or crawling upon the land, though they abounded upon the turnips; while, on the undressed stetches, they were to be seen in great numbers both on the wheat and on the land. The quantity of slugs thus collected was near a bushel. Mr. Rodwell is persuaded that by this plan, he saved his wheat from essential injury. (*Kirby and Spence, Int. to Entomology*, i. p. 182. note.)

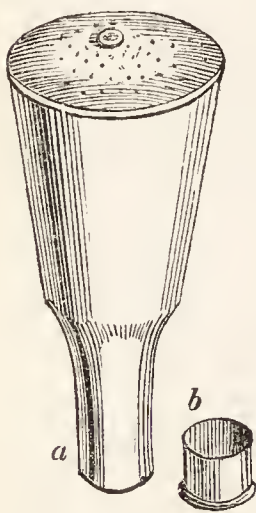
977



7699. *The turnip net* (fig. 977.) is an instrument invented by Mr. Paul of Starston in Norfolk. It is the most successful expedient that has yet been thought of for the capture and destruction of the little beetles called by farmers the black jack, and by hop-growers the flea. It consists of two pieces of stout wood, the ends of which, at one extremity, are fixed into a handle in a forked direction: the other ends are left thick and curved upwards, for the purpose of passing the instrument smoothly and easily over the surface of the ground: towards this end, the sticks are connected by a cross-bar formed by a thin iron rod, that may be taken on and off at pleasure; these three sides constitute the frame work for supporting a long and ample bag, made of strong glazed calico. The method of using it is by the operator shoving it before him on the ground, over the tops of the turnips or other plants; by this means the insects that are upon the leaves fall into the bag, which may be occasionally shaken during the process, so as to bring them to the bottom (which is made narrow) where they will remain. Vast quantities of insects, which from their smallness and agility defy hand-picking, will be thus captured. The turnip net may be made either large or small; perhaps two feet and a half for the side sticks is the best length; it being obvious that the wider they are apart, the greater space will be brushed at once,

7700. *The lime-duster* (fig. 978.) is a recent invention by Mr. Samuel Curtis of Glazenwood, near Coggeshall, Essex, and has been used by him with great success in throwing pulverised quick-lime over apple trees infected by caterpillars and other insects. His orchard, containing many thousand fruit trees, and occupying fifty acres, had been for many years completely divested of most of their foliage and young fruit in the spring months. Washing the stems and branches with lime and water (as might have been expected) was found ineffectual for the destruction of insects which fed only on the young buds and leaves. The instrument in question consists of a canister twelve inches long, seven inches wide at its broadest, and four inches on its narrowest part; the handle (*a*) is five inches and a half long. The top of the handle is fitted with a cap (*b*), which is put on when the lime is to be thrown on low trees; but when high trees are to be operated upon, the cap is removed, and a pole of sufficient length to reach the height required is inserted into the handle. Quick-lime pulverised (and often sifted through a fine sieve) is put into the canister, and shaken over the young foliage just as it was expanding. The time for doing this is in the dew of the morning, or whenever the leaves are damp; and if there should be a gentle breeze, sufficient to carry the dust obliquely through the head of each tree, it is the more quickly performed. Under favourable circumstances of this nature, Mr. Curtis says, "I found that three men, provided with the powder in a large box on a light wheelbarrow, could dress from two to three thousand trees in a day: when the wind changed, I had the trees dressed on the other side. Although used ever so freely, no person need fear any injury, from the caustic quality of the lime, on the most delicate and fresh expanded foliage; it is only prejudicial to insects of all kinds, and to dead vegetable matter." (*Hort. Trans.* vol. vi. p. 2. page 124.) We know not whether the lime-duster has

978



ever been tried upon hop plantations infected by the green fly or plant louse; but it appears to us equally well adapted to effect a great destruction among those insects.

7701. *Grain of all descriptions* that is infected by weevils, or by the grubs of other insects, should be spread in the sun, and frequently turned: the warmth will bring the animals out of the grain, and considerable numbers may be destroyed. It has been said that they may be kept away by strewing boughs of elder or branches of henbane among the grain, but this wants confirmation.

7702. *Hand-picking*, independent of the foregoing methods, is too tedious and too ineffectual for general adoption in large crops, but is probably the best that can be resorted to in gardens or small enclosures. In this way the different esculent vegetables, and the common and low kinds of fruit trees, as currants, gooseberries, &c. may be cleared of a vast number of caterpillars.

7703. *Catching the perfect insect* is undoubtedly the most certain plan for preventing a return of the same injury the following year, for the death of one female will cut off a generation of a hundred larvæ; but from the difficulty that attends an extensive adoption of this plan, it is not likely to be much attended to.

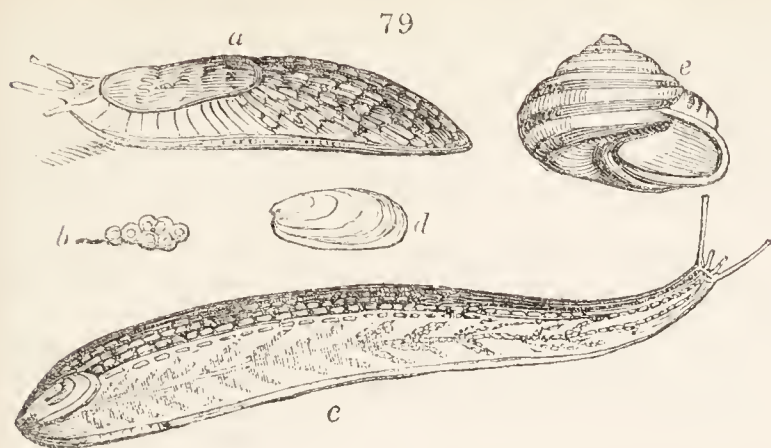
SECT. IV. *Worm-like Animals injurious to Agriculture.*

7704. *Of worms* (*Vermes L.*) generally so called, there are but few which may be considered as injurious to agriculture. The principal of these are the various species of slug (*Arion F.*, *Limax L.*) and the large and small snails (*Helix hortensis* and *nemorâlis L.*), mostly found in garden plantations. The earth or dew worm (*Lumbricus terrestris L.*), unless existing in great numbers on a single spot, cannot be ranked among injurious animals, notwithstanding the prejudices of farmers and gardeners against them. Without worms the earth would soon become hard, cold, incapable of receiving moisture, or of giving nourishment to roots: they are, in fact, the great promoters of vegetation, by boring, perforating, and loosening the soil beneath, and by manuring it above with their excrement, which is thrown up into lumps called worm casts. The wire-worm does not belong to this tribe, but is the larva of a small beetle already noticed.

7705. *Worms of the slug kind* are without shells. There are several species inhabiting Britain, all of which subsist on leaves, roots, and vegetables. The most common is the *Limax agrêstis* (fig. 979. *a*), of which there are several varieties injurious to the agriculturist and gardener; they devour the young shoots of turnips, wheat, and indeed all kinds of grain, frequently to a ruinous extent: their eggs (*b*) are small, round, of a semipellucid whiteness, and are deposited in the earth. The methods of destroying or eradicating the perfect animal have been already described.

7706. *The shell slug* (*Testacellus mângi F.*, *c*) is a native of Teneriffe, and has likewise been found in several parts of France and Spain; it has recently been discovered in some gardens near Bristol, by Mr. Miller, of that city. It is a highly curious animal, remarkable for feeding upon earth worms; and may, therefore, be beneficially introduced into such gardens as are overstocked by that otherwise

useful animal. It is readily distinguished from all other slugs in this country by having a thin oval shell



(*d*) affixed to the hinder part of its body. Slugs in general are easily enticed by cabbage leaves, scattered near such garden vegetables as they appear to injure most.

7707. *Snails*, are slugs covered by a shell. The two species most prejudicial to cultivated vegetables, are the garden snail (*Hélix aspersa Gm.*), and the variegated snail (*Hélix nemoralis, e*): both these seek the same description of food, and are equally injurious, as slugs; and, like them, may be enticed by cabbage leaves and other juicy vegetable refuse.

PART IV.

STATISTICS OF BRITISH AGRICULTURE.

7708. AFTER having considered agriculture as to its history, as to the scientific principles on which it is founded, and the application of these principles to the different branches of practice; it remains only to take a *statistical survey and estimate* of its present state and future progress in the British isles.

BOOK I.

OF THE PRESENT STATE OF AGRICULTURE IN THE BRITISH ISLES.

7709. *The present state of British Agriculture*, as to knowledge and the details of practice, has been the subject of the former PARTS of this work: but its importance in the general economy of society, can only be learned by a view of the manner in which it is actually carried on; the modifications to which it has given rise in the pursuits of those who have embraced the art as a source of livelihood; of the kinds of farms cultivated by different orders of agriculturists; of the principal practices of each of the different counties of Britain and Ireland as to agriculture; of the British authors who have written on the subject; and of the professional police and public laws relative to husbandmen and agriculture.

CHAP. I.

Different Descriptions of Men engaged in the Practice or Pursuit of Agriculture.

7710. *Agriculturists* may be arranged as operators, or serving agriculturists; dealers, or commercial agriculturists; counsellors; professors, or artists; and patrons.

SECT. I. *Operators, or serving Agriculturists.*

7711. *The lowest grade in the scale of this class is farm labourers*, who may be either men, women, or children; and either local residents, periodical visitants for particular labours, as hay-making, reaping, &c., or itinerant workmen for taking jobs, as ditching, stocking, &c. None of this class of operators are supposed to have received any other professional instruction than what they have derived casually, or from observing others.

7712. *Apprentices* are little known in agriculture; but they occur sometimes, either as the children of other operators, whose parents bind them a certain number of years, during which they are to work for their food and clothes, and 5*l.* or 10*l.* to be received at the end of the term according to conduct; or sons of richer persons, who pay a premium for the instruction to be received, and for boarding with the master. The former class of apprentices generally look forward to being ploughmen, shepherds, head ploughmen, or inferior bailiffs; the latter to being first bailiffs, stewards of estates, or to farming on their own account. Parish boys are sometimes bound apprentices of the first class, and various noblemen's sons from almost every kingdom of Europe have been included in the second.

7713. *The term journeyman* is as little known in agriculture as apprentice. Those who answer to that term are the professional operators of a farm, such as ploughmen, cattle herds, shepherds, and hedgers. These rank decidedly above labourers of all-work. A ploughman may not unaptly be considered as of the rank of an apprentice till he can *fear* or set out ridges, and after he can do this as of the rank of journeyman till he can stack and sow. He may then be considered as a master of his art, entitled to work the best pair of horses, and if twenty-five or thirty years of age, to enter into the marriage state.

7714. *A hedger* is a professional operator, who may be considered as ranking with a master ploughman. His business is to plant, clean, prune, cut, lay, plash, and repair hedges; prune forest and orchard trees, and effect other operations with ligneous plants on the farm. In Berwickshire hedgers are generally very intelligent men, and keep the fences on the farms in the border counties in excellent order, and the hedge-row trees handsomely pruned.

7715. *A woodman* is an operator employed to prune trees and manage hedges, and is of the same rank and requires the same kind and degree of professional knowledge as the hedger. Generally he is more conversant with barking trees for the tanners, converting copsewood and measuring timber, than the other, being more engaged with woods than hedges.

7716. *A head ploughman*, on small farms, is to be considered as the bailiff in the absence of the master. He works the best pair of horses, and assists the master in stacking and sowing. On larger farms, where a regular bailiff is kept, there is also a head ploughman, who acts as substitute for the bailiff in his temporary absence, as far as operatives and overlooking operations; but not in money matters or contracts.

7717. *A farm bailiff* is, or should be, a person of tolerable education, who understands accounts, measuring of work, land, and timber, and can draw up agreements for hiring servants. He should have practised every part of farming himself, from tending poultry, swine, and sheep, to stacking and sowing. When employed by a gentleman, or one who has no skill in farming, he should not be under twenty-five years of age; but a farmer's bailiff need not exceed twenty-one years, is to be considered as a sort of apprentice, and will be directed in all leading matters by his master.

7718. *A bailiff and gardener*, or gardener and grieve, as they are called in some places, is a sort of hybrid upper servant, who seldom excels either as a farmer or a gardener, and is only fit for situations of limited extent, and an indifferent style of performance.

7719. *The forester* or head woodman is to the woods of an estate what the bailiff is to the farm lands in hand. He directs and superintends the woodmen and their labourers, in planting, rearing, and pruning plantations, and in the felling of timber or copse, barking, charcoal making, and in short every thing connected with timber, trees, copses, or hedges.

7720. *The land steward* (*Factor*, Scotch; *Facteur*, Fr.; *Factor*, Ger.; and *Fattore*, Ital.) is to a whole estate what a bailiff is to the demesne or a particular farm. His business is to control the managers of the lands in hand, as the forester, gardener, bailiff, &c.; to see that farmers fulfil the covenants of their leases; to attend to repairs, roads, public and parochial matters in behalf of the landlord; and generally to receive rents.

7721. *Under stewards*, or steward's bailiffs, as they are called, are assistants to the main steward, or have the care of detached estates, containing a few farms or woods.

7722. *Demesne stewards* are such as are kept chiefly for regulating the affairs of demesne lands; that is, lands surrounding the mansion in hand, or of an estate of small size, where all the lands are in hand, but where an extensive establishment of horses, servants, a large garden, &c. are kept up. Here the steward performs the duties of bailiff, forester, and in some degree of house-steward, by his connection with the stables and game-keeper, and other domestic rural matters.

7723. *Court farmer* (*Hoffmeyer*, Ger.; *Grangero de la corte*, Span.; *Agronome de la cour*, Fr.; and *Fattore della corte*, Ital.), may be considered the highest step, the *summum bonum* of agricultural servitude. The late Ramsay Robiison, Esq. was bailiff to Geo. III.; his sister, Miss Robiison, was royal dairy-woman; and Sir Joseph Banks, royal shepherd.

SECT. II. Commercial Agriculturists.

7724. *The lowest grade here is the jobbing farmer*, who keeps a team, a cart, plough, pair of harrows, and probably one or two hand implements. He hires himself by the day, week, or by the acre, to plough, sow, or labour, the small spots of ground of tradesmen who keep a cow but no labouring stock; or to assist farmers who are behind with their labours. The contractors for executing works devised by the agricultural engineer (7754.), though widely separated in point of wealth from the common jobber, yet belong to the same species; both agree in selling their labour and skill in a raw state, not when manufactured into produce like the other commercial agriculturists.

7725. *Itinerant agriculturists* are of two kinds: such as take grounds for the culture of one or two crops of particular sorts of plants, as woad, flax, &c. (5963.); and such as travel with a plough and pair, &c. to teach that operation to young farmers or their servants, a practice at one time carried on in Ireland under the patronage of the Dublin Society.

7726. *Cottage farmers* are such as possess a cottage and an acre or two of land, which they may either keep in aration or pasture; disposing of the corn, green crops, or dairy produce in various ways, according to local circumstances.

7727. *Poultry farmers*, such as devote themselves chiefly to the breeding, rearing, and fattening of poultry, and the growing of feathers and quills.

7728. *Garden farmers* are such as possess lands near large towns or sea-ports; and grow the commoner garden vegetables, as peas, onions, cabbages, &c. for the market, or herbs for the distillers and druggists.

7729. *Seed farmers*. Small farmers who devote themselves chiefly to the growing of garden seeds for the London seedsmen, and for the distillery. They are to be found only in a few counties in the central and southern districts of England, and chiefly in Kent and Essex. (See *Encyc. of Gard.* 2d edit. 7390.)

7730. *Orchard farmers* are such as farm grass or arable orchards, sometimes joined to hop lands and garden farms; often with a small dairy; with rearing of poultry, rabbits, &c., and sometimes with the breeding and training of dogs; the latter a very lucrative branch when well understood.

7731. *Hop farmers*, such as make hops a principal article of cultivation, to which are sometimes joined garden and orchard farming.

7732. *Milk or cow farmers*, such as keep cows for selling their milk in an unmanufactured state. These farmers are of course limited to populous neighbourhoods. Cow-keepers differ from cow-farmers, in having their establishments in towns, and in purchasing, not growing, their cow provender.

7733. *Dairy farmers*, such as keep cows and manufacture their milk into butter or cheese. These are most common in rich moist flat districts, as Cheshire, part of Gloucestershire, Leicestershire, &c.

7734. *Graziers*, farmers whose chief business consists in buying, feeding, and selling cattle and sheep. Their farms are chiefly in old pasture, and they are more commonly feeders than breeders. The most extensive in England are in Leicestershire and Lincolnshire.

7735. *Stock farmers*, such as devote themselves to breeding and rearing different kinds of live stock, especially horses and cattle. They are most common in Yorkshire.

7736. *Store farmers*, breeders who devote themselves chiefly to the sheep and cattle families. They are common in the border counties, in Wales, and in the Highlands.

7737. *Hay farmers* are confined to a small district round London; where they grow chiefly natural or meadow hay for the London coach and saddle horses, and for cow-keepers.

7738. *Corn-farmers*, as opposed to hay, dairy, grazing, and breeding farmers, is a term employed to such as occupy lands more adapted for the plough than for pasturage, as arable clays and loams.

7739. *Wood-farmers*, such as rent woodlands, to be periodically cut for fuel, bark, fence-wood, charcoal, or other purposes.

7740. *Quarry-farmers*, such as rent quarries of lime or other stone, gravel-pits, clay-fields, marl-pits, &c.

7741. *Mine-farmers*, or master miners or mine-holders, such as rent coal-mines, or mines of iron, lead, or other metals.

7742. *Salmon or river-farmers*, or fishery renters, such as rent rivers or ponds for the sake of their fish.

7743. *Commercial or professional farmers*, such as farm lands for profit. Those who farm an extent of good land under one hundred acres are considered small farmers; under three hundred acres, middling farmers; above and under five hundred acres, large farmers; and exceeding that quantity, extensive farmers: a very proper title, for few arable lands can be profitably cultivated to a greater extent in one farm or by one establishment than five hundred acres, and those which exceed that quantity are generally breeding or other stock farms, characterised by their extent.

7744. *Gentlemen farmers*, are professional farmers on a large scale, who do not associate with their minor and personally working brethren; but who affect in their style of living the habits and manners of independent men or gentlemen. It is a character extremely liable to ridicule by the vulgar yeoman and purse-proud farmer on the one hand, and those persons who are gentlemen by profession and men of family on the other.

7745. *Yeomen farmers*, small proprietors who farm their own lands, but yet aspire not to the manners and habits of gentlemen.

7746. *Farming landlords*, proprietors who farm their own lands on a large scale.

SECT. III. *Agricultural Counsellors, Artists, or Professors.*

7747. *The land-measurer* is the lowest grade of agricultural artists: he is very often the village school-master, and is called in to measure work done by the job; as mowing, reaping, hedging, trenching, &c.

7748. *The agricultural salesman* is a person who attends at fairs, markets, &c., and acts as agent to buyers and sellers of corn and cattle. There are also salesmen purposely for hay and straw, others for green food, turnips, potatoes, &c.

7749. *The appraiser*, or valuer of farming-stock, comes next in order. This professor values the live and dead stock, and crop, tillages, manures, &c., and sometimes also the remainders of leases between outgoing and incoming tenants, or betwixt tenants and their landlords. Occasionally the appraiser is employed to value lands, but this is generally the business of the land-valuer.

7750. *The land-surveyor* generally confines his avocations to the measuring and mapping of lands; or to their subdivision, or the arrangement of fences and other lines; but sometimes he joins the business of appraiser and valuer, and even timber-measurer.

7751. *The timber surveyor and valuer* confines himself in general to the measurement and valuation of fallen or standing timber; he also measures and estimates the value of bark, faggots, roots, charcoal, ashes, willows, hoops, and various other products of ligneous plants.

7752. *The land-valuer* not only values the rental, but the price or fee-simple of lands, buildings, woods, quarries, and waters. He does not often meddle with metallie or saline mines; but he sometimes values fisheries, stone and lime quarries, brick-earth, gravel, chalk, &c. This profession requires not only a general knowledge of agriculture in the most extensive sense of the word, but a very extensive acquaintance with the country in which the property lies, and great experience in business. There are local and general land-surveyors and land-valuers: the general professors live in the capital cities or in the metropolis, and generally unite the business of land-agent.

7753. *The land-agent* may or may not be a land-valuer, but at all events he should possess the knowledge of the valuer in an eminent degree. His business is to effect the transfer of property by purchase, sale, hiring, or letting; and also to collect rents, and often to re-let farms, and effect other business belonging to the land-valuer. Land-agents are very frequently attorneys, who know little of agriculture; but who save their employers the trouble of employing both a land-steward of superior abilities, and a lawyer to draw up agreements and leases. It is the opinion of the best informed agriculturists both of Britain and France, that the employment of attorneys as land-stewards and agents has been one of the chief causes of the retardation of agriculture throughout Europe. Chateaufort has clearly shown how this cause has operated in France and Italy; and Dr. Henderson, Arthur Young, Marshal, and various others, have deprecated its influence in Britain. The love of precedent, which these men cannot abandon from habit; the love of litigation, to which they adhere from taste and interest; and the ignorance of agriculture, from the nature of their education; are the causes that have counteracted the tendency to change and amelioration.

7754. *Of agricultural engineers* there are considerable variety. *The drainer*, for laying out drains and water-works; *the irrigator*, for watering the surface of grass-lands; *the road engineer*, for laying out roads; *the mineral surveyor*, for searching for, measuring, mapping, and valuing mines and minerals; *the coal viewer*, for estimating the value of coal works; *the rural architect*, for designing and superintending the execution of agricultural buildings; and *the hydrographical and canal engineers*, for canals, harbours, mills, and the greater water-works.

7755. *The veterinary surgeon*, or agricultural doctor, is to be considered as a rural professor; and as subordinate grades, may be enumerated the farrier (*Ferrier*, Fr.; *Ferrajo*, Ital., a smith, from *ferrum*, Lat. iron), cowleech, and castrator or gelder.

7756. *The agricultural draftsman*, or artist by way of eminence, is employed in designing and painting live-stock, implements, plants, and cultivated scenery; the plans of farms are taken by the land-surveyor, designs of buildings made by the architect, and new inventions in machinery and implements are drawn by the inventors, whether millwrights or agricultural mechanists.

7757. *The agricultural author* may be considered as the most universal kind of agricultural counsellor, since his province includes every branch of the art, and comprehends times and practices past, present, and to come. The simplest variety of this species is the author of single papers in magazines, or the transactions of societies; the most extensive, he who embraces the whole of the subject; and the most valuable, he who communicates original information.

7758. *The professor of agricultural science* (*Professeur d'Agriculture ou d'Economie Rural*, Fr.; *Hochlehrer von Ackerbau*, or *II. von Landwirthschaft*, Ger.; *Professor d'Agricoltura*, Span.; and *Professore d'Agricoltura*, Ital.), when appointed by a permanent or national institution, may be reckoned the highest grade of agricultural counsellor: since he is not a self-constituted instructor, like the author; but constituted by competent judges as capable of instructing the public. The first public professor of agriculture appointed in Britain was Dr. Coventry of the University of Edinburgh, about 1790; and the next Sir Humphry Davy, Lecturer on Agricultural Chemistry to the Board of Agriculture, about 1807: both highly eminent as agricultural counsellors, independently of their other merits. There are agricultural professors in Dublin and Cork. In almost every University on the Continent there is an agricultural chair, and in some of the German and Russian Colleges there are chairs for gardening (*Gärtnercy*), forest-culture (*Forstwissenschaft*), and rural architecture (*Landbaukunst*).

SECT. IV. *Patrons of Agriculture.*

7759. *Every man being a consumer* of some description of agricultural produce, may be considered a promoter of the art by causing a demand for its productions. The more valuable consumers are such as

live on the best bread, butcher's meat, fowls, and dairy products; and the greatest of all patrons, both of agriculture and gardening, are such as fare sumptuously every day.

7760. *Amateur agriculturists*, lovers of agriculture, promote the art by the applause they bestow on its productions; of which, to a certain extent, they become purchasers, as of farming books, prints of cattle, implements, &c.

7761. *Connoisseurs*, critical or skilful lovers of agriculture, promote the art in the same way as the amateur, but much more powerfully, in proportion as approbation founded on knowledge is valued before that which arises chiefly from spontaneous affection. By the purchase of books, models, attendance at agricultural exhibitions, &c., connoisseurs encourage both counsellors and commercial agriculturists. Sometimes, also, by their writings, of which Sir John Sinclair is an eminent example.

7762. *Employers* of agriculturists, whether of the serving class, as bailiffs, stewards, &c., or of the order of professors or artists, are obvious encouragers of the art.

7763. *Amateur farmers* are patrons on the same principle as employers; and sometimes, also, they effect improvements, or communicate valuable information to the public. Cline, the late eminent surgeon, and the late physician, Dr. Parry, were eminent examples.

7764. *Noblemen and proprietor farmers* are conspicuous patrons. They render the art fashionable; and by the general attention so directed, and consequent occupation of many minds on the same subject, new ideas are elicited, and dormant talents called forth and employed. The names of Russel, Coke, Curwen, and Somerville stand preeminent among this species of patrons, and many others might be added.

7765. *Noblemen and gentlemen improvers*, whether by planting, building, road-making, establishing villages, canals, harbours, &c. are evidently greater patrons of agriculture than noblemen farmers, since their improvements affect society more extensively. As decidedly at the head of this species of patron may be mentioned the late Duke of Bridgewater and the present Marquess of Stafford, and to these names might be added a number of others.

CHAP. II.

Different Kinds of Farms in Britain relatively to the different Classes of Society who are the Occupiers.

7766. *Cottage farms* form the first link in the chain of temporary terrestrial possessions. They consist of one or more acres appended to a cottage, for the purpose of enabling the occupier to keep a cow: if any part of this farm is in aration, the labour is either hired of some jobbing agriculturist, or done by spade; or two or more cottagers join together and form a team of their cows, with which, and implements borrowed from the village carpenter or smith, they accomplish their labour.

7767. *Farms of working mechanics*. These are larger than the former, and are rented by country blacksmiths, carpenters, &c., who often keep a horse or a pair of horses. Both this and the former sort are very often injurious to the occupiers, by drawing off their attention from their principal source of income; though it must be confessed at the same time, that the idea of occupying land, and raising one's own corn, clover, milk, butter, eggs, pulse, &c. is highly gratifying; gives a sort of sense of property, and has an air of independence and liberty, highly valued by men in general.

7768. *Farms of village tradesmen and shopkeepers*. Many of these men, such as bakers, butchers, grocers, &c. keep a horse at any rate; by renting a few acres they are able to keep another, and add a cow, and other minor species of live stock. The attention required from the master forms a healthful recreation, and agreeable variety of occupation; and if this recreation does not interfere with main pursuits, there is a gain of health and respectability.

7769. *Farms occupied with a view to profit by town and city tradesmen*. These are on a larger scale than the last, and held by stable-keepers, cow-keepers, butchers, corn-dealers, &c. They are often of considerable size, mostly under grass, and managed by bailiffs. Arable farms in such hands are rarely well managed, as every thing is made to depend on manure; but as less skill and vigilance is required in managing grass-lands, hay or pasture farms of this description are generally well manured, and consequently productive. They are seldom, however, profitable, and it is only because the renter reaps the double profit of grower and consumer, has some enjoyment in the idea of the thing, and some increase of health from the requisite visits to it, that he finds it suitable to continue his farming operations.

7770. *Farms occupied by city tradesmen for recreative enjoyment*. These are of various descriptions, and generally managed by bailiffs. They may be considered as affording recompense only by the amusement, exercise, and health which they afford, and the interest in country matters which they excite. Many a worthy man thus throws away, almost at random, on agriculture, what he has gained by trade with the greatest industry and frugality, often joined to skill and ingenuity. When the farm promises well, the tradesman is sometimes tempted to sell his trade and turn farmer for good (as it is called, *i. e.* for a principal occupation), and often ends in impoverishing, or even ruining himself.

7771. *Farms attached to the villas and country houses of wealthy citizens*. On these the wealthy citizen plays at agriculture, aided by a skilful manager or bailiff. Immense sums of money are thus expended in the neighbourhood of large towns; many ingenious practices are displayed; and though nothing in the way of profit is ever expected to be gained, yet on the whole an attention to agriculture is excited in the minds of wealthy commercialists, who buy books on the subject, procure bailiffs, approved implements and breeds of stock; and thus give encouragement to these and other productions connected with the subject. The history of farming for the last twenty years round Edinburgh, Liverpool, and London, affords some curious, singular, and extravagant examples of this description of farming, and some of a much more judicious description.

7772. *Demesne farms*, or such as are occupied by the landed proprietors of the country. These are of a great many different kinds; some regularly appended to the park; some comprising a part of the park separated by temporary fences; and others taken into occupation without regard to situation. Some proprietors take all the farms on their estate successively into their own hands, cultivate them for a few years, bring them into excellent order, and then let them to farmers. Much good is often done by proprietors occupying land themselves; new practices, and new kinds of vegetables and live stock, are exhibited and disseminated; and the landlord himself, being instructed by experience in the practice of farming, is better able to judge what his land should let for; and more likely to appreciate good tenants, and sympathise with the losses of his farmers in bad seasons. Add also, that a proprietor in this way procures better butcher-meat of every kind than he could generally purchase in the neighbouring markets; and, if he chooses, better legumes and roots, and even better cabbages and other culinary vegetables than he could grow in his kitchen garden. The bailiffs on such farms are, or ought to be, well educated men, brought up to farming in the best districts. They should be well paid, and have sub-bailiffs under them. The establishments of Bedford, Coke, Curwen, Albemarle, &c. are or were among the most complete in this kind of farming.

7773. *The farms of professional farmers*. It must be obvious, that this class includes more than nine tenths of all the farms in the country. They are of every description of soil, climate, situation, &c. which the country affords; of all manner of sizes, according to the demand created by such as follow farming as a business; and either devoted to the general purposes of corn and cattle, or more particularly for poultry,

milking, dairying, garden crops, hops, orchard crops, grazing, breeding, hay, corn, wood, minerals, as stone quarries, &c., or to fisheries. At the origin of what we now call farming, or when the hiring of land by cultivators succeeded to cultivating them for the landlords, or in partnership with the landlords, as is still the case in Italy and most other countries, farms would of course be small, and farmers' men of scarcely any capital or consideration in society. Just emancipated from a state of bondage and villanage, the new-created independent tenant could not easily throw off the chains which formerly shackled his mind and prevented his energies from being brought into action, and he could have little or no property when he had no means of acquiring it but by plunder, or preserving it but by concealment. Hence the first tenants were assisted by their landlords; and one remnant of this practice, that of allowing farmers to have a year's rent always in hand, or, in other words, not to demand the rent till half or a whole year after it is due, still exists in some parts of Scotland and Ireland. In process of time, however, and from various direct and indirect causes, farmers at length acquired some degree of capital and respectability; and as they naturally thought of employing the former, of course farms began to be enlarged to afford scope, and leases granted to afford security. This practice has been going on in Britain for more than two centuries past, and receives a fresh impulse whenever the prices of grain rise high, and continue so for some time. At no period have they been so high as about the commencement of the present century, and during no period have the riches and respectability of farmers so much increased. More recent political changes, however, have proved singularly disastrous to farmers; and till the corn laws are either obliterated, or regulated on some permanent and more moderate principle, agriculture and its practisers of every description will remain liable to the extremes of profitable occupation and ruin.

CHAP. III.

Topographical Survey of the British Isles in respect to Agriculture.

7774. *The British isles*, as we have already observed (1280.), are, in their present state, naturally and politically more favourable to the practice of the agriculture of ale, butcher-meat, and wheat, than any other country in the world. They have their disadvantages both in climate, and in civil and political matters; but, notwithstanding, there is no country in the world where farmers or proprietors are so respectable a class of men, and where such excellent corn, herbage, roots, and hay, either raw, or in their manufactured state of bread, ale, and butcher-meat, are brought to market.

7775. *The following outline of the state of agriculture in each of the different counties of the United Kingdom* is taken from the *Surveys* published under the authority of the Board of Agriculture, or the Dublin Society; from Marshal's remarks on these surveys, and his other writings; and, in some cases, from our own observation, having at various periods, since the year 1805, been in almost every county in Britain, and in most of those in Ireland. Agricultural improvement is often of so variable and fleeting a nature, that, notwithstanding our utmost care, some things may be found here inserted as such that no longer exist; and from the period, varying from twelve to twenty years, which has elapsed since the surveys were published, many improvements may have been made deserving of insertion which are omitted. These are unavoidable defects attendant on this part of our work; but though we cannot render it perfect, yet we are of opinion we can bring together a sufficient number of facts, as to the natural and agricultural circumstances of each county, as to render it both interesting and useful to the reader. We regret much, that notwithstanding our most earnest invitation to the readers of the *Gardener's Magazine* to send us corrections and additions for this part of the work, yet we have received so few, that we are unavoidably obliged to send into the world the second edition of this chapter, in November, 1830, almost as imperfect as was the first, in November, 1825.

SECT. I. *Agricultural Survey of England.*

7776. *The surface of England* is estimated at from thirty-two to thirty-six millions of acres, with the exception of some mountains in Cumberland and Westmoreland, almost every where cultivated, and nowhere incapable of cultivation; in most places varied, gently and beautifully in some districts, and abruptly and on a grander scale in others. The most high and mountainous districts are those of the north, and the most level those of the east. The most humid climates are those of the north-western counties; as Cheshire and Lancashire; and the most dry those of the south-east, as Norfolk and Suffolk. The richest grass lands are in the vales of the great rivers, as the Severn, Trent, and Thames. The richest arable lands, in Worcestershire, Warwickshire, and in part of various other counties; and the best farming, in Northumberland, Durham, and Cumberland. The greatest variety of farming may be seen in the counties round London; and the greatest sameness, regularity, order, science, success, and the wealthiest farmers in Northumberland and the county of Durham. The geology and minerals of the kingdom are most ably indicated in *Smith's Geological Map of England, Wales, and part of Scotland*, 1815; *Smith's County Geological Maps*, 1819 to 1824; and *Smith's Geological Table of British Organised Fossils*, 1819. These works are of the greatest importance to landed proprietors.

7777. MIDDLESEX is part of the north side of a vale watered by the Thames, and contains 192,000 acres, exhibiting a great variety of agriculture. (*Middleton's Survey*, 1806. *Marshal's Review*, 1818. *Edin. Gaz.*, 1827.)

1. *Geographical State and Circumstances.*

Climate. Healthy; warmer near London, from the fires kept there, which consume 800,000 chaldrons of coals annually; stationary winds from the S. W. and N. E., those from the S. W. blow 6-12ths of the years, N. E. 8-12ths. Greatest falls of rain from a few points W. of S. and are of the longer continuance when the wind has passed through the east to the south. In spring, frost in the hollows, when none on the hills, thermometer has been as high as 83°, and as low as 6° below zero.

Soil. By long continued manuring, the surface soil almost every where looks like loam. Sand and gravel on Hampstead Hill. Loamy sand from Hounslow to Colnbrook. Sandy loam on west side of Hanwell and Hounslow. Strong loam about Ryship, Pinner, Harrow, and South Mimms; loamy clay between Uxbridge Common and Harefield. Clay of the most adhesive and ungrateful kind about Hendon and Highwood Hill; peat from Rickmansworth to Staines, on a substratum of the gravel of flints. Marsh land or rich loam deposited from still water in the Isle of Dogs, and on the Lea and Coln.

Surface. Gently waving; highest towards the north. Hampstead 100 feet above the level of the sea. One mile from London on the Kingsland Road, the surface of upwards of

1000 acres is lowered at an average five feet from the brick earth dug out, which of ordinary quality has produced 4000*l.* per acre; and when marly, for malms or white bricks, 20,000*l.* per acre. Brick earth formerly 100*l.* per acre, now 500*l.* per acre. An acre at four feet deep yields four millions of bricks.

Mineral strata. 1. Cultivated surface. 2. Gravel of flints, 5 or 10 feet in thickness. 3. Lead or blue clay, 200 or 300 feet in depth. 4. Marine sediment, 3 or 4 feet in depth. 5. Loose sand, gravel, and water, the latter arising in such quantities as to prevent digging deeper.

Water. Abundant and excellent. The Thames, from Oxford to Maidenhead, falls about 24 feet in ten miles; from Maidenhead to Chertsey Bridge, 19 feet in ten miles; thence to Mortlake, 13 feet per ten miles; and to London, one foot per mile; from London the fall diminishes till it is lost in the sea. Tide flows twenty-three miles up the Thames. Spring water found at various depths, from 5 to 300 feet; the latter, the depth of Paddington.

Mineral waters at East Acton, Hampstead, and Bagnigge-wells; chalybeates little used.

Fish caught in the Thames. Sturgeon, salmon, tench, barbel, roach, dace, chub, bream, gudgeon, ruffe, bleak, eels, smelts, and flounders.

2. State of Property.

Estates and their management. Generally under the care of attorneys, and badly managed.

Tenures. Much freehold, considerable extent of copyhold, some church, college, and corporation land.

3. Buildings.

Houses of proprietors. Numerous, splendid, commodious.

Farm-houses, offices, repairs. Oldest built with timber lathed and plastered, roofs thatched; erected piecemeal; situated in villages, sides of lanes, and near large ponds. Those built within the present century, of brick, and covered with tiles. Farmery of Sutton Court, Chiswick, Wickgreen, and Isleworth, models of their kind. Very few buildings required on hay farms.

Cottages, brick and tiled, and generally in villages; formerly with right of common, now done away by enclosures.

4. Mode of Occupation.

Size of farms. Generally small compared with other counties; three cow-farms near town, from 500 to 600 acres each, rented at from 2000*l.* to 5000*l.* each. Many of 200*l.*; average of county 100*l.*

Character of the farmers. Four classes. 1. Cow-keepers, gardeners, and nurserymen. 2. Amateur farmers of fortune. 3. Amateur farmers, who have left other pursuits. 4. Commercial or professional farmers, equal in number to half the others.

Rural artificers. Bad; impossible to get any agricultural implement or machine made on a good principle by the country artificers; but able mechanics in London; Cottam and Hallen, Wykes and Phillips, Snowden, and especially Weir, a Northumberland man, and practically acquainted with agriculture.

Rent paid in money, sometimes a small part in butter and cream at fixed prices. Varies from 10*s.* to 10*l.* per acre, or higher for nurseries.

Tithes in many places taken in kind, in some compounded for annually, or for a fixed period.

Poor, and the rates for their relief, average 5*s.* 6*d.* per acre.

Leases, general. Often for fourteen and twenty-one years, drawn up by lawyers—"a composition of obsolete unintelligible covenants."

Expense and profit. Expenses on entering a farm, greater than in distant places: profits seldom more than a mere subsistence to the farmer. The increase of canals, and the prospect of steam carriages and locomotive steam-engines on railroads, is rapidly rendering distant and near farms and farmers' profits on a level.

5. Implements.

All bad; plough barbarous; threshing mills rare.

6. Enclosing.

Now mostly enclosed. Nineteen commons enclosed from 1800 to 1806, containing 20,000 acres and upwards. Old fences of a mixture of white and black thorn, maple, hazel, briar, crab, damson-plum, &c.; new of white thorn with ditch and bank; gates mostly five-barred, and of oak; enclosures too numerous.

7. Arable Land.

About 14,000 acres; wretchedly managed, ploughed with teams of three or four horses; rotation generally fallow, wheat, beans.

8. Grass Lands.

Meadows better managed; hay-making good.

9. Gardens and Orchards.

From Kensington through Hammersmith, Chiswick, Brentford, Isleworth, and Twickenham, seven miles of garden ground; may be denominated the great London fruit garden, north of the Thames. An upper and under crop taken at the same time; the upper the fruits on trees; the under strawberries and various herbaceous crops. To increase shelter and warmth in autumn, they raise banks of soil 3 feet high, facing the south, and sloped to an angle of 45°; on these they plant endive in September, and near the bottom, from October to Christmas, they drill a row of peas; the endive is preserved from rotting, and the peas come to maturity nearly as early as if under a wall. The springs here lie eight or ten feet under

7778. SURREY. A surface of 519,040 acres beautifully varied: poor and heathy in the west, chalky in the east, and clayey in the south. The field cultivation of clover and turnips appears to have first taken place in this country. (*Stevenson's Survey*, 1813. *Malcolm's Survey*, 1809. *Marshal's Review*, 1818. *Smith's Geological Map*, 1821. *Edin. Gaz.*, 1827.)

1. Geographical State and Circumstances.

Climate. Healthy winds S.W. and W.: seldom blows from any point between N.W. and N.E. for any time. East winds in spring, and then weather cold, raw, and drizzling. Most rain falls when the wind is S.S.W. or S.

Soils. Various and most irregularly distributed; a broad zone of tenacious clay bordering Sussex: patches of brick earth at Walworth, Sutton, and Stoke. Considerable extent of chalk hills from Croydon to Nutfield, and thence narrowing to the western extremity of the county. A good deal of black rich land interspersed among all the soils.

Surface. St. Anne's Hill, Cooper's Hill, and Richmond Hill celebrated; Leith Hill the highest, commands a prospect of from thirty to forty miles on every side.

Minerals. Iron ore, fuller's earth, firestone, limestone, and chalk. Iron-works on the decline, on account of the dearth of fuel. Abundance of fuller's earth in the southern part of the county, which has been dug since the beginning of the eighteenth century. Excellent firestone: when first quarried soft; kept under cover a few months becomes compact, and able to endure the action of a common fire. Owing to this stone, Dawson, proprietor of the Vauxhall plate-glass works, can make plates of such a size as to surprise the French, from whom he discovered the art of plate-glass making in the disguise of a common labourer. Excellent limestone at Dorking, which hardens under water; contains a little flint. Chalk used chiefly as a manure. The sand about Ryegate the finest in the kingdom, and in considerable demand for egg and hour glasses, writing-sand boxes, &c. At Nonsuch, there is a bed of brick earth, from which fire bricks and crucibles are made.

Water. Scarce in many places, particularly on the chalk. Several supplies procured round London, by boring down from one hundred to five hundred feet to the chalk stratum, where

the surface, and the water is raised from the wells by a bucket and lever, balanced by a stone. (*fig.* 152.) Three thousand acres of garden ground here, employing five persons, a man, his wife, and three children, per acre, during the winter half-year, and during summer, five persons more, chiefly Welsh women. Estimated produce 100*l.* per acre.

Kitchen gardens. Much fresh littery dung required for growing mushrooms, early cucumbers, salads, potatoes, asparagus, &c. Consumption of the metropolis and its environs, for fruits and vegetables, estimated at upwards of a million sterling per annum. Several farming gardens pay 1000*l.* per annum.

Nursery grounds. About 1500 acres, producing 75,000*l.* a year.

10. Woods and Plantations.

Copses and woods decreasing for ages: still a few acres near Hampstead and Highgate.

Hedge-row timber much disfigured by being pollarded or pruned to may-poles.

Willows or osiers. Many islets on the Thames, rented by basket-makers, and planted with osiers; also, wet borders of the river so planted. Species *Salix vitellina*, *amygdalina*, or almond-leaved, and *vininalis*, or osier; willows when cut made up in bundles, or boulds, forty-two inches round, at sixteen inches above the but-ends.

11. Improvements.

Draining, to carry off surface water. The mode of making surface gutters on meadows, by means of an addition to cart-wheels (3979.), invented by the reporter.

Manure produced in London by 50,000 horses, 8000 cows, and 700,000 human beings, equals 500,000 loads; of which, half is carried into the Thames by the sewers, including ninety-nine per cent of the night soil.

12. Live Stock.

Less live stock on the farms of this county than in any other: no breeding. Short horned cows of Holderness chiefly used by milkmen: number kept 8500; average produce nine quarts per day; fed on hay, turnips, brewer's grains, linseed cake and jelly, and grass: retail dealers adulterate the milk, preferring dirty water to clean; and adulterate the cream by adding molasses and a little salt. Very little butter made in the county. Brewer's drays supplied with horses from the Berkshire farmers, who buy them young from Northamptonshire, and work them two or three years before they sell them. Not more than one dove-house in the county; but many pigeons kept in empty wine pipes set upon posts, fifteen or twenty feet high, and many kept by journeymen tradesmen, pigeon fanciers in the poorer parts of London, and most other towns and villages of the county.

13. Rural Economy.

Half the manual labour done by the job; labourers ruined in morals and constitution, by the public houses. Gentlemen's servants a bad and contaminating set.

14. Political Economy.

Highways of the parishes good, turnpike roads generally managed on Macadam's principle, and good; several canals terminate in or near London; and New River for supplying water; fairs on the decline. Uxbridge the greatest corn market next to Mark Lane. Great cattle markets, Hounslow and Smithfield. Commerce great. Manufactures not many; considering agriculture as a manufacture, and the soil as the raw material, and worth 16*s.* per acre, at an average of England; it is increased in value to 5*l.* or 52*l.* per cent. Distilleries and breweries numerous.

15. Obstacles to Improvement.

Tithes, land-agents being attorneys, bad leases, bad rural artificers, bad and thieving servants.

16. Miscellaneous Observations.

Society of Arts, Veterinary College, excellent institutions. Fines called heriots should be removed; weights and measures lately regulated; much damage is done by game.

17. Means of Improvement.

Ample in the metropolis, and the progress rapid; in the country, want of intelligence the grand drawback.

the water is excellent, soft, and abundant. Artesian (from the county of Artois, where such wells were first brought into notice,) wells are now so numerous in the neighbourhood of London, that in places where the water formerly rose in the bore three or four feet above the surface, it will now scarcely reach the surface. (*Mag. Nat. Hist.* vol. ii. and iii.)

Fish ponds common on the heaths, at the western side of the county; have been used for upwards of two centuries, for breeding and rearing carp and other fish. One of the largest, containing one hundred and fifty acres, is near Hershams.

Mineral waters numerous. Epsom water is impregnated with sulphate of magnesia, and is purgative. Epsom salts originally made there, now chiefly from common salt water at Lymington in Warwickshire. The other springs are more or less impregnated with sulphate of magnesia, carbonate of lime, and iron.

2. State of Property.

No large estates: largest 10,000*l.* a year. Yeomanry not numerous; but some gentlemen round Guildford farm their own estates of from 200*l.* to 400*l.* per annum. Estates mostly managed by attorneys; so far proper as to law terms, but as absurd as to agricultural restrictions, as it would be to employ a farmer to draw up the covenants in technical language. Till the farmer becomes active, inquisitive, free from prejudice, and intelligent, no covenants, or care of attorneys and stewards, will prevent him from injuring himself and his landlord by bad husbandry. When he becomes active, &c. he will take care of the landlord's interest for the sake of his own; and the first step to forcing the farmer to become active and intelligent is to leave him to the exertions of his own mind. Tenures chiefly freehold.

3. Buildings.

Few counties that can vie with Surrey in the number and

elegance of its country seats. (*Encyc. of Garden, Surrey.*) Possesses a great advantage over the north and east of Middlesex and Essex, in this respect, as the prevalence of the S.W. winds drives away the smoke of London. Proprietors generally reside on their estates, and eagerly introduce improvements.

Farm houses and offices. Ruinous and mean in the weald, or clayey district bordering on Sussex; better in other places. Oldest of brick covered with slate, stone, or brick nogging and tiles; situations seldom central or convenient to the farm, in villages. Stables not divided into stalls. Cow-houses near London, good. Cottages often large, convenient, and picturesque; with a porch, a flower-plot, and vine in front.

Drinking ponds. Great attention paid to these on the Surrey hills; generally a first pond, where the water deposits its gross dirt and mud before it enters the second.

4. **Occupation.**

Farms of all sizes, but mostly small, forty and fifty acres to three hundred. Largest farm between Guildford and Farnham is Wanborough; it contains 1,600 acres; formerly occupied by Morris Birkbeck, and now by his son. Average size one hundred and seventy acres. Tendency to large farms, by which the public is unquestionably benefited, certainly by the saving of labour, and, in all probability, by the superior cultivation and increased produce. The driven out farmer may generally support or enrich himself equally well though in a different line of life. "But in every country, in all situations and circumstances, and in our own country, particularly in the situation in which it is now placed, it is of the highest importance to consider, whether a mere increase of wealth may not be purchased too dearly; whether it be prudent or wise to diminish the number of those whose souls are knit to their native land, by stronger ties than are known to the mere manufacturer. To the patriot, it can be little satisfaction to see his country the richest in the world, if the measures and causes which make it rich diminish in the most trifling degree, its independence; either by raising any passion above the love of our country, or by diminishing the number of those who must be its most natural and powerful defenders. To the moralist it can afford little pleasure to be told, that by the saving of agricultural labour, the manufactures of his country will be extended or increased, if he perceive that by the change of employment the health and virtue of part of the community are sacrificed." (*Stevenson.*)

Farmers. Old class about the clayey wealds, equal enemies to improvements in agriculture, and relaxations in morals: have no idea of educating their sons, and so little of the spirit of commerce, that they prefer selling their grain to an old customer at a lower price than taking a higher from a new one. Go to market in round frocks, the dress of their forefathers, and shy and jealous to strangers. Nearer town the farmers are more on a level with the age; but either unable or unwilling to communicate information; some exceptions of liberal, enlightened, and communicative men. Many tradesmen have turned farmers, and occupy lands near town.

Rent low. Tithe rigidly exacted, poor's rates and other outgoings high.

Leases general, for fourteen or twenty-one years, or on three lives.

5. **Implements.**

Great variety of ploughs, swing ploughs, the Scotch swing plough used only in two places; bad effect of so many different sorts of ploughs on the servants. The cultivator used by Birkbeck, and highly approved of: — with six horses, goes over eight acres in a day. Lester's friction threshing-machine introduced in a few places, and found to succeed: but it threshes very slowly, and has no advantages over Meikle's, but that of not breaking the straw of wheat. This advantage is too trifling ever to render it general. Very few winnowing machines. Sowing troughs in use, the advantage of which is, that the sower fills it himself instead of having a woman, toiling through rough ground. Smut machines also in use, in one or two instances. (2796.)

6. **Arable Land.**

Proportion considerable, tillage bad. Drilling, though introduced by Duket of Esher, and strongly recommended, is confined to a few adjoining parishes, where the soil is light. Fallowing on clays general, but most imperfectly executed. Rotations generally good.

Turnips, supposed to have been grown in Surrey as long or longer than in any county in England. Sir R. Weston, of Sutton, having described the Flanders culture in 1645, and as he addressed his book to his sons, it is thought they would attempt culture. Very badly cultivated at present, and seldom in raised drills. The Siberian turnip has been tried; it is a variety between the cabbage and turnip, but with a root inferior in point of size and flavour to the latter, and a branchy loose top: it does not seem adapted for field culture, though as a novelty it deserves trial and attention. Carrots answer well on the sandy soils. Potato tops sometimes given to cows, cut when in flower; a bad plan with a view to the tubers. Clover introduced by Sir R. Weston at the same time as turnips. Saintfoin succeeds well on calcareous soils, producing good

crops for eight years. In forming a new road through a field of saintfoin, between Croydon and Godstone, the roots were found to have penetrated several yards below the surface. The culture of hops, brought from Suffolk to Farnham about A.D. 1600; prefer a calcareous sub-soil: occupy 800,900 acres. Farnham hops esteemed more than others, because picked earlier, and hence more delicate, and better sorted. Peppermint, lavender, wormwood, chamomile, liquorice, and poppy, grown near Mitcham; and more extensively than in any other county. One hundred acres of peppermint. Elecampane, rhubarb, soapwort, coltsfoot, vervain, angelica, rosemary, the damask and red roses, hyssop, horehound, marsh mallow, pennyroyal, and several acres of daisies, wall-flowers, sweet-williams, primroses, violets, pinks, batchelors-buttons, and the like, are also grown for Covent Garden market, where they are carried, either as entire plants in flower with balls for planting in town, flower-pots or in pots, or the flowers are gathered and sold for nosegays. Weld is grown in a few places.

7. **Grass Land.**

But in small proportion to the rest; most pasture in the wolds. Paring and burning considered by Birkbeck as the best first step of breaking up old grass lands.

8. **Gardens and Orchards.**

Asparagus grown in great quantities at Mortlake, East Sheen, and Battersea. Radish and other seeds also grown extensively at Battersea. Onions for seed at Mortlake and Barnes: though chiefly at Deptford. Three thousand five hundred acres of Surrey employed in raising vegetables for the London market. Orchards attached to many of the farms, sufficient to supply from four to twelve hogsheads of cider. Generally in a very bad state of cultivation; trees covered with moss; many walnuts grown at Norbury, and at some other places; produce 20 to 50 bushels per tree.

9. **Woods and Plantations.**

The wold formerly a wood: some copse there still: shoots for hoops grown; charcoals for gunpowder made from hazel, dogwood, &c.; common charcoal, hop-poles and faggots. Box Hill, formerly called Whitehill, by tradition originally cultivated, till the Earl of Arundel, in the reign of Charles I., brought box trees from Kent, and planted there. Many with good reason think it not planted, but aboriginal. Soil of the hill, pale loam or chalk; timber now all cut; brought only five pounds per ton. Many fir trees on chalk hill: at Crowhurst, one fifty feet high and thirty-six in circumference. Brooms made from the ware or spray of birch to a great extent. Fine limes at Beckworth. Osier holts or grounds about Chertsey and Byfleet, brought the same rent one hundred and fifty years ago which they do now. Furze grown for the burning of bricks; sown both broadcast, and in drills; cut every three years, and bound like corn, then stacked.

10. **Heaths, Commons, and Common Fields.**

Extensive heaths on south-west; surface flat, soil back sand, and gravel. A number of commons, and great extent of common-field lands.

11. **Improvements.**

Draining, paring, and burning. Manuring with London manure of a great variety of kinds.

12. **Live Stock.**

Very considerable; only six hundred and nineteen cows, kept for supplying London with milk.

Duket of Esher used to rear calves to a great extent; many cattle fed by the distillers and starch manufacturers. Adam of Mount Nod, one of the architects of that name, has constructed extensive buildings for cattle, and stall-feeds six hundred at a time. Sheep kept in considerable numbers on the chalk hills and wealds. Birkbeck has been very successful in cross-breeding with merinos, that is, with the Ryeland merino of Dr. Parry, and the South Down. Immense number of pigs fed at the distilleries, and of geese kept on the wealds. Dorking hens are well known. (7445.) A hare warren near Banstead Downs, already described. (7365.)

13. **Rural Economy.**

Hands scarce; servants unsettled; prejudiced, like many of their masters, against all new practices.

14. **Political Economy.**

Bad roads, though flints and other good materials abound in many places. An iron railway between Wandsworth and Westham for general use; the first in the kingdom of that kind, the rest being confined to the carriage of goods belonging to individuals; this open to all who choose to employ the waggons; as a canal is open to all who choose to employ the boats. Though on a level, and admitting of carriage both ways, yet not found to pay. The first canal locks in England were erected on the Wey. Sir R. Weston, of Sutton, brought the contrivance from Holland; and, under his direction, the Wey was rendered navigable from Guildford to Weybridge, about 1690. Numerous fairs; several flour, paper, and oil mills. An extensive iron work at Garratlane, near Wandle; a mill for staves at Stoke; a delft manufactory at Mortlake. A horizontal air-mill of a new construction at Battersea bridge; several distillers, brewers, and starch manufacturers. Poor, numerous and degraded. Poor's rates enormous.

7779. SUSSEX. A maritime county of upwards of 900,000 acres; distinguished by chalk hills and extensive wealds, a rich soil, but little excellence or variety of agriculture: excels in South Down sheep. (*A. Young's Sussex*, 1809. *Marshal's Review*, 1818. *Smith's Geological Map*, 1819. *Edin. Gaz.*, 1827.)

1. **Geographical State and Circumstances.**

Climate. Warm in western parts, bleak on South Down hills; westerly gales violent, unroof stacks, hedges injured by the spray of the sea.

Soil. Chalk nearly the universal soil of the South Down hills; clay of the wealds, which constitutes more than half the surface of the county. Rich land about Chichester, and sand and gravel in a few places.

Surface hilly, most so where the soil is chalk. No high hills.

Minerals. Sussex or Petworth marble used by the statuaries, but not generally. Limestone, ironstone, sandstone, chalk, marble, and fuller's earth.

2. **State of Property.**

Largest estate 75000. a year. Most proprietors hold land in their own occupation, and pay great attention to its cul-

ture, as E. of Egremont, D. of Richmond, E. of Chichester, Lord Sheffield.

3. **Buildings.**

Noblemen's seats splendid, of stone; farm-buildings generally of stone; on the South Downs built of flints: houses very generally faced with tiles, which keeps the walls dry. Corn generally stacked on circular stone piers, which prevents vermin. Sheep-yards, or permanent folds walled round, and furnished with sheds and hay-racks, have been built by Ellman and some other eminent sheep farmers on the Downs. Large wooden barns. Cottages of stone, and on the Downs of flints, and more comfortable than in many parts of England. Magnificent semicircular piggery, erected by E. of Egremont, at Petworth.

4. **Mode of Occupation.**

The most extensive farms on dry soils. Average of the

wealds 100 acres. Size on the Downs 1200 to 2000 acres. Tithe taken in kind in many places, in others compounded for. Poor's rates high.

5. Implements.

Plough with two whels, large and singularly clumsy. The Rotherham plough introduced, and deemed a real improvement. Several excellent new implements introduced by the noblemen already mentioned.

6. Enclosing.

County enclosed from earliest antiquity; fields small; hedges very irregular and broad. White thorn fences at Goodwood, by the Duke of Richmond, trained in a masterly manner; being like walls, or rather hogged manes of verdure rising from the earth.

7. Arable land.

Tillage bad, three or four horses to a plough with a holder and driver; plough from one half to three quarters of an acre a day; following general on the stiff soils. Rotation bad, barley often follows wheat. Wheat trod in on the sandy lands; threshed by flail, and generally cleaned with a shovel and broom; one or two threshing and winnowing machines. Oats a great deal cultivated on the wealds. Peas much cultivated on the South Downs. Hops much cultivated on the eastern part of the county; but not found profitable. Rhubarb, and the poppy for opium cultivated by E. of Egremont. The roots of the rhubarb, after growing seven or eight years, are taken up, washed, dried in the sun, and then cut in slices and dried on the hot-house flues. (6176.) Incisions are made in the poppy heads, and the exuded juice, when dry, scraped off into an earthen vessel, dried in the sun, and preserved for use. Incisions are made as long as milk flows. André, the domestic surgeon, uses the home-grown rhubarb and opium, and no other. Saintfoin does well on the chalky soils, and lucerne near Eastbourne and Brighton. Lord Egremont tried 100 acres of chicory, and found it support much stock, though on a poor soil.

8. Grass Land.

Badly managed; overrun with rubbish. One person tried hay oiled when stacking; he oiled every layer, with a watering pan and rose, lightly with linseed oil; the hay came out moist and clammy; and it is said that beasts, and sheep were fond of it, but it was deemed too hot for horses. Salt sprinkled on hay when a little damaged found a great advantage; it is done in stacking.

9. Orchards.

Some considerable orchards, and cider made. One or two fig orchards at Tarring, near Worthing. (See *Encyc. of Gard. Sussex.*)

10. Woods and Plantations, 175,000 acres.

County celebrated from the remotest antiquity for the growth of its timber, especially oak. County at the conquest one continued forest, which extended from Hampshire to Kent. Underwoods cut at twelve years, for hoops and hop-poles. Ash the most profitable underwood. Finest oak timber at Petworth.

11. Wastes.

Of considerable extent to the north of the county. Some hundreds of acres improved by E. of Egremont answer well.

12. Improvements.

E. of Egremont sent for Elkington to find water to fill a lake. E. undertook to do so; but all his trials and predictions of the effect of certain borings and open cuts, which he caused

7780. KENT (*Cant or Anglc*) forms the south-east corner of the kingdom, and extends over 900,600 acres. It is diversified by chalky eminences in some places, low marshy grounds on the Thames and part of the sea-coast, and an inland, flat, and woody tract bordering on Sussex, called the Weald, or wood (Saxon). It is one of the oldest cultivated counties in England; it was noted even by Julius Cæsar, as "the civilest place of all this isle, and full of riches." Viewed from the great road from Dover to London, it has, with the exception of the Downs near Dover, a more garden-like appearance than any county in Britain. Its agriculture is various; and it is celebrated for the culture of hops, fruits, barley, and various garden crops. (*Boy's Kent*, 1796. *Marshal's Review*, 1818. *Smith's Geological Map*, 1819. *Edin. Gaz.*, 1827.)

1. Geographical State and Circumstances.

Climate. Subject to cold winds; the prevailing are the N. E. and S. W.; former in winter, attended by severe frosts, twelve inches of ice, and the destruction of turnips. Milder in S. W. part of the county. In Sheppy and Thanet an early harvest, commences July 20. on the hills 1st August.

Soil. That of Thanet rich on rock chalk; of East Kent very various; chalk, loam, strong loam, hazel mould, stiff clay, flint, gravel, sand. Isle of Sheppy strong stiff clay; West Kent very various, but chalk and loam on chalk rock prevails; Weald chiefly clay, but mould, sand, and gravel in a few places. Romney Marsh sediment of the sea; a soft loam and clay.

Surface. Gently varied hills of chalk; Downs not so high as those of Sussex.

Minerals. Numerous chalybeate springs, at Tunbridge Wells the chief.

2. State of Property.

Much divided; number of yeomanry on the increase; 9000 freeholds, and a good deal of church and college lands; socage and gavelkind tenures prevalent.

3. Buildings.

Twenty or thirty noblemen's seats, and many seats of gentlemen and citizens, merchants, bankers, &c.; few modern-built farm-houses; old ones of oak or chestnut, and ill contrived; thatched; now improving considerably. Cottages are in general comfortable, built with bricks and tiles.

4. Mode of Occupation.

Size of farms greatest on poor lands; many farms from ten to fourteen acres each, few exceed 200 acres, some 600 to 1500 acres. Tithes in many parts collected in kind. Leases for fourteen years most common. Many church leases on three lives, some on twenty-one years, renewable.

5. Implements.

Kentish turnwrest plough almost the only one known in the county, drawn by four horses in heavy, and three in light, soils. Corn rakes in use after mown corn. Stubble rakes to drag stubble together; first threshing-machine erected at Betsinger by the reporter.

to be made, proved abortive and false: no water was found. Failed in three remarkable instances at Petworth, but drained a meadow very well. Lord Egremont considers him as not a scientific drainer, but a very good common drainer, and nothing more.

13. Live Stock.

Cattle and sheep among the best in the kingdom; total amount of sheep kept is about 450,000; cattle red; little dairying; generally breeding and feeding. Oxen worked extensively by E. of Egremont and Lord Sheffield; broken to the yoke at two years and a half; yokes five feet long used and preferred by Lord Egremont. Lord Sheffield harnesses the same as for horses; twelve oxen and nine horses required to work 200 acres in tillage. For hoven cattle one quart of linseed oil given, which vomits them directly, and never fails in giving relief. South Down sheep celebrated. Ellman the first breeder both of cows and sheep; breeds from the same race. New Leicester and Spanish breeds introduced to the county by Lord Sheffield. Rabbits abound and flourish every where, and are the nuisance of the county. Fowls fattened to great perfection at North Chappel and Kinsford: food, oats ground, hog's grease, sugar, pot liquor, and milk, all mixed; or oats, treacle, and suet; also, sheep's plucks; they are kept very warm, and crammed morning and night; put into the coop two or three days before they begin to cram them, which is done for a fortnight, when they weigh 7 or 8 lbs. each, and are sold to the higgiers; average weight 5 lbs., but some weigh double. One of Lord Egremont's tenants crams 200 fowls a year; many capons fed in this manner; great art requisite in castrating them, and numbers die in the operation. The Dorking or Darking fowls extensively raised in the wealds of Sussex; Horsham principal market for them.

The fish-ponds on the weald are innumerable: carp the chief stock; but tench, perch, eels, and pike, are raised. A stream should always flow through the pond, and a marly soil is best. Carp fed with peas in marl-pits have weighed 25 lbs. per brace. Carp kept five years before selling; then twelve to fifteen inches long; 100 stores, or one-year-old carp will stock an acre. At one year old, carp is three inches long; at two years old, seven; at three, eleven or twelve inches; at four, fourteen or fifteen; and then they breed. Lord Egremont has breeding and feeding ponds; fishes them every three years.

14. Rural Economy.

Labour high, as smuggling attracts away many young men.

15. Political Economy.

Roads bad on the clayey districts, good on the chalky. Rother river rendered navigable at Lord Egremont's expense. Fairs numerous. Manufactures of iron, charcoal, gunpowder, paper, bricks, and potash. Large court of poor-houses at Eastbourne, of which a plan and elevation is given in the "Report." In 1772, a society was established at Lewes for the encouragement of agriculture, manufacture, and industry, by John Baker Holroyd, Esq., now Lord Sheffield, and premiums offered; but, on the breaking out of the war in 1778, it was dropped. In 1797 Lord Egremont established a society at Lewes, and gave large premiums. This society still exists. The patriotic and charitable exertions of E. of Egremont are most extensive. He gives away to proper objects immense quantities of clothes; food twice a week; feasts all the labouring classes at Christmas; and keeps a surgeon, apothecary's shop, and midwife, entirely for their service: they are also inoculated, and instructed gratis, &c.

6. Enclosing.

No common-field lands but several commons; fences old and broad, belts of copse more frequent than thorn hedges. Water fences eight to fourteen feet wide, and from three to five feet deep in the marsh lands; post and rail fences prevalent in Romney Marsh. Neither fences, drains, nor water furrows wanted in Thanet, where corn is grown, and often, for years in succession, without manure.

7. Arable Lands.

Plough for all crops from five to seven inches deep. Fallows always made on poor lands. Rotations good. Peas of various kinds for podding are sown from the middle of February to the end of March. Leadman's dwarf and the early grey thought the most prolific. Canary seed and radish seed much cultivated in Thanet and East Kent for the London seedsmen. Radish seed sown in March, and crop seldom fit to reap before October, and is sometimes out on the fields at Christmas without receiving any injury from wet weather; requires much rain to rot the pods that it may thresh; will produce from eight to twenty-four bushels per acre. Spinach sown in March in Thanet; when in blossom the male plants (it being a dioecious plant) are pulled and given to pigs with advantage. Crop threshed on the field; produce, two to five quarters per acre. Kidney-beans much cultivated at Sandwich and in Thanet for the London seedsmen; plant from five to ten gallons per acre between the 8th and 20th of May; if earlier in danger of frosts; pulled up by roots from August to October, tied up in bunches and hung on poles to ripen; produce, ten to twenty bushels per acre. Cress and white mustard sown at the rate of two or three gallons per acre in March; reaped in July and threshed in the field; produce, eight to twenty bushels per acre. Weld sown among beans at the last boeing in the beginning of July; ten or twelve lbs. of seed per acre; pulled when in bloom, which happens the second year, in July, and tied in single handfuls to dry; when dry bound in bundles, weighing thirty lbs.: sixty of these a load; produce, from one half to one and a half load per acre. Sometimes remains in stocks or barns for several years for want of a market; at other times 21l. per load; generally bought by speculating merchants, who supply the dyers with it as opportunity offers. Madder formerly much culti

vated in the eastern part of the county, now given up; first cultivated on a large scale near Feversham.

8. Grass.

Hay chiefly produced in the marshes and the weald; pastures for dairying on every farm; but no dairy farms of any extent in the county; lands in Kent seldom changed from grass to arable, or the contrary. Hay-making badly conducted in most parts of the county, owing to the scarcity of hands. In Thanet and East Kent lean sheep and cattle brought in and put on the marshes and meadows till fit for the butcher.

9. Gardens and Orchards.

Near all the great towns a considerable portion of land devoted to the cultivation of vegetables; at Deptford and Gravesend are whole fields of asparagus, onions, cauliflowers, &c.; at Maidstone, many fields of from one to ten acres of fruit trees; apples, cherries, and filberts, raised among hops, the culture of which causes the former to grow with great luxuriance; common practice to plant 800 hop hills, 200 filberts, and forty apple and cherry trees per acre; the hops stand twelve years, filberts thirty, and the apples and cherries an unknown length of time. Sometimes apples and cherries in alternate rows with two rows of filberts between; filberts also raised among hops without any other trees; trees planted in holes two feet square, and two spits deep; pieces of rock taken out; trees stalked and their stems brushed over with lime and night soil, which is said to make them grow exceedingly. The golden rennet apple and black heart cherries, when a few years planted, found to gum and die; yet many old trees in full vigour: cherries do best with land laid down to grass; filberts answer on few soils; best cider maker Stone of Maidstone, mixes all sorts of apples; golden pippin makes good cider alone; no occasion to watch the fermentation of cider in order to rack it off at any particular time, as alleged in Herefordshire; eating apples sent to London by the hoys, and to the north of England by the coal vessels. Fruit orchards considered the most valuable estates. Tithe on fruit 2s. per pound on sales. Cherries require a deep soil, and bear well for thirty years; filberts a stony, shattery, sandy loam, rather inferior; they will not bear in rich soil; principal hop grounds about Canterbury and Maidstone, on deep rich loam with a subsoil of loamy brick earth; produce two to fourteen or fifteen cwt. per acre; average seven cwt.

10. Woods and Plantations.

Principal produce hop poles, fuel; husbandry wood, and some little for the dock yards; few artificial plantations.

11. Improvements.

Open drains made between flat ridges by deepening the furrows; turf and brushwood drains in use; chalk will answer when below the reach of frost; sea beach and refuse bricks also

used. Several windmills which drive pumps to drain the water from marsh lands. Some bogs drained under the direction of Elkington, and now good meadows. Sea-weed used as manure; several thousand loads are sometimes thrown ashore by one tide, and washed away by the next; generally mixed with some yard dung, which it helps to rot; sand spread on stiff soils without being of any use; powdered kelp sown at the rate of twenty cwt. per acre on pasture, saintfoin, and clover, without any perceptible benefit; weeding a general practice; county long noted for its clean crops of corn. Thistles in grass lands mown while in bloom never come up again. Some land in Thanet recently embanked from the sea; bank thirty-six feet at base, nine feet high, and three feet wide at top; base of outside angle twenty-two, of inner eleven feet. Borders of the Medway below Rochester offer great scope for embanking, and perhaps warping.

12. Live Stock.

Neither a dairying nor grazing county: little attention paid to the breed of cattle. Romney Marsh breed of sheep remarkable for fattening early. Fine teams of heavy horses kept at a great expense. A few rabbit warrens; the rabbits within these few years affected with the rot. Formerly many pigeons, now few; few poultry but for home consumption; few bees.

13. Rural Economy.

Labour generally done by job; servants, scarce, dear, and saucy.

14. Political Economy.

Roads generally good, formed of chalk and flints; or limestone and gravel; roads in the weald very bad for want of materials. As clay is there abundant, if duty taken off bricks they might be burned on the spot and the roads paved; 340,000 will pave a road one mile long and nine feet wide. No canals, but one near Gravesend; fairs and weekly markets very numerous. Agricultural commerce of county consists chiefly in exporting corn to London markets. Manufactures trifling. At Down and Maidstone paper mills; at the Isle of Grain salt works; in the Weald iron works; and at Whitstable and Deptford copper works. Gunpowder made at Deptford and Feversham; calicoes printed, and linens whitened, at Crayford. Poor well taken care of; earn from forty to sixty pounds per annum, by hop picking and other rural employments for their wives and children.

15. Miscellaneous Observations.

Kent Agricultural Society, established at Canterbury in 1793, by Sir E. Knatchbull and F. Honeyman, Esq. Some potatoes dried on an oat kiln were found to retain their properties during long voyages, as attested by letters from the vic-tualling office.

7781. ESSEX, 942,720 square acres, the greater part marshy grass lands near the Thames, and the rest arable lands of a mixed culture, chiefly of corn and herbage. It is an old cultivated county; contains many small gardens and seed-farms near the towns, and is one of the few districts in the south-east of England where the plough is drawn by only two horses. (*Young's Survey*, 1810. *Marshal's Review*, 1818. *Smith's Geological Map*, 1820. *Edin. Gaz.* 1827.)

1. Geographical State and Circumstances.

Climate mild; north and east the prevailing winds, which bring blights to plants, and cold and hoarseness to animals; ague general both in the high and low lands.

Soil almost every where a loam, and more generally heavy than light. Generally well adapted for grass or corn.

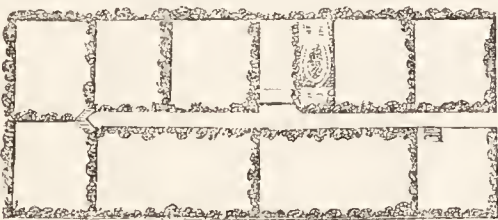
Surface beautiful about Havering (Have a ring) from Romford to Lord St. Vincent's and Lord Petre's, both fine seats on the Stour; also very fine from Sharbury to Harwich.

Water abundant, in rivers, creeks, and springs.

2. State of Property.

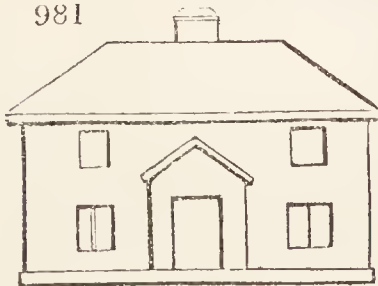
Estates vary much in size from 5l. to 20,000l. a year: In no

980



county a greater population of small and moderate-sized farms occupied by their owners. Managers of large estates sometimes

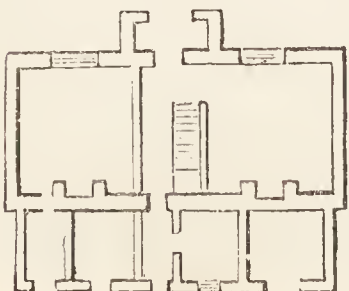
981



attorneys, capital farmers, or private gentlemen. Farmers of all sorts; land held by farmers on short leases, often at will, sometimes on eight, ten, or twenty-one years' leases. Some of the seed or garden farms neatly laid out (*fig.* 980.).

3. Buildings.

Wanstead one of the largest houses in the kingdom; in 1825 pulled down. Audley-end well known. Misty Hall a most striking place. Gosfield and Thorndon, the latter finely wooded by the scientific Lord Petre. Many others; but some districts of the county with very few seats. Farm houses good, out-buildings numerous and convenient; expensive rick covers and barns. Cottages not



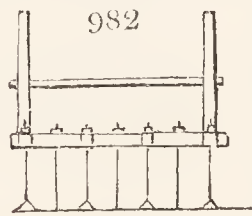
very good; some built on a better plan (*fig.* 981.) by the Duke of Buckingham, with a garden of one fourth of an acre to each. Joseph French, at East Horndon, finding labour dear, and servants difficult to be got, took the plan of fixing them by building them cottages and attaching gardens.

4. Occupation.

Some of the largest farms in the kingdom; so early as 1767 Arthur Young found some at 1500l. and 200l. a year. Lord Braybrook farms 1100 acres, Lord Petre 1468. Many farmers men of information, ingenuity, and exertion. Tithes average 4s. 9d. to 6s. per acre when compounded for. Many farms held on running leases, terminable or renewable every seven years. The refusal of leases increasing.

5. Implements.

Essex plough, a large unwieldy implement, with two wheels. A great variety of swing ploughs, all bad compared with the Rotherham kind or Northumberland plough. An iron road cleaning plough by Western; a concave roller and scraper attached, delineated in the report, but no reason given for the



shape. Many cultivators, scufflers (*fig.* 982.), &c. delineated, and a donkey hoe. Some of Pasmore of Doncaster's threshing-mills, and winnowing machines, in use. The Scotch cart, plough, and other improved implements introduced by Western. Flemish scythe tried, but found not to answer; did not understand its use. Pat-tison of Maldon has made an ingenious improvement of the common sowing basket; he has made the bottom a wire sieve for sifting out the seeds of weeds in the motion of sowing, and attached a cloth bag beneath for catching them. An ant-hill machine. Good specimens there of amateur improvements on implements.

6. Enclosing.

Essex for ages an enclosed county; still some waste to enclose. Hedges broad and mixed plants, and with pollard trees.

7. Arable Lands.

Cultivated better than nine in ten of the other counties: plough with two horses or three horses abreast without a driver; fallows universal; rotations good; potatoes cultivated to a great extent for the London market. Carrots in various places planted for seed three feet apart; produce five or six cwt. per acre, sometimes ten or twelve; rye-grass disliked generally; wire-worm comes after it, and is sure to destroy wheat. Rape, ribwort for seed; hops in a few parishes. Saintfoin succeeds well on poor calcareous soils; some lucerne. Wire-worm often injurious to young wheat, after clover leys; rolling and treading lessens its effects; on strong soils slugs very troublesome. Panned for the excellence of its wheat, which always obtains a high price in the London market.

8. Grass Lands.

Extensive marshes and salt-ings (or salt-islets).

9. Gardens and Orchards.

Some cherry orchards at Burnham; many cottages without gardens.

10. Woods and Plantations.

Fifty thousand acres, chiefly natural and ornamental scenery. Some fine old elms at Gossford. At Saint Osyth the three original Lombardy poplars which Lord Rochford brought from Italy about 1758, and from which the greater part of those in the kingdom have been raised; they are seventy feet high and seven feet three inches in circumference, five feet from the ground; a Portugal laurel more than fifty-two yards in circumference, and a very large *A'rbutus*. The largest abele trees in England at Bellhouse, Aveley; large elms; Lord Petre has sold thirteen oaks for 600*l.* at 15*l.* a load including top and bark. Oaks at Hatfield worth 100 guineas each. Hatfield broad oak celebrated, but now in ruins. An oak at Wimbish increased in girth four and a half inches in thirteen years; a larch, two feet nine inches in the same time; the larch, however, was younger.

11. Wastes.

Fifteen thousand acres; said that in James the First's time almost the whole county was waste.

12. Improvements.

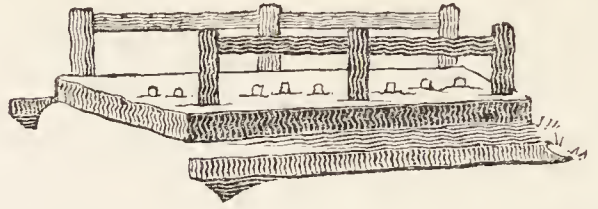
A good deal of draining; a machine in use like the Flemish mouldebaert (*fig. 59.*) for lowering the surface of ploughed lands at those places where they intend making cross-furrows to carry off the water from the regular furrows. The draining wheel (3978.) in use, inventor not mentioned. Chalk much used as a manure.

13. Live Stock.

Essex never famous for this branch. The largest dairy farms at or near Epping, famous for its butter and cream; no particular sort of cows kept; Derby and Leicestershire breeds preferred, but any taken; fed on natural and artificial grasses in summer, and hay and grains in winter: dairies built on the north sides of the farm-houses; milk kept in troughs lined with lead, which hold nine to ten gallons of milk, five to six inches in depth. This in winter is skimmed four, and in summer two or three times, and the cream, after being kept three or four days, churned; milk given to hogs. A few cows kept for milk; in other places for suckling calves, and feeding on the marshes. Western has the finest swine in the county; feeds them in what he calls a hog case; a cage which effectually prevents the animal from taking exercise. A hog half fat put into a case gains fifteen pounds a week, if well fed with barley meal and water. A miller, near Maldon, has made a treble case on wheels, to keep moving about on grass land, for its improvement. A portable bridge, carried on a pair of wheels, for passing sheep over marsh ditches, in use by Wakefield of Bournham. (*fig. 983.*) A decoy for ducks and other aquatic

birds in Mersea island, the largest in the county. Every person that approaches a decoy takes a piece of lighted turf stuck

983



on a table fork in his hand, to prevent the ducks from smelling man. Without this caution they will quit the pond. A decoy at Goldhanger, at which one waggon load and two cart loads of dun birds were taken at one haul of the nets; but the disturbance so frightened such as escaped, that no more were taken that season. Seven fish ponds at Spaines Hill for carp, tench, and eels. A chain of ponds at Leigh's Priory, belonging to Guy's Hospital, near a mile in length, and occupying about thirty acres, once completely sluiced and carefully cultivated, now dry and neglected.

14. Rural Economy.

Labour done generally by the piece.

15. Political Economy.

Roads mostly good; few canals; various fairs; and some cattle markets. In the creeks of Crouch, Blackwater, and other rivers and estuaries, considerable quantities of oysters are deposited for breeding. The produce is afterwards dredged and deposited at Wivenhoe and other places for feeding. What are called Colchester oysters are fed there, and sent to Hamburg, Flanders, and France, in time of peace, as well as to London. Oysters are also dredged on the Hampshire coast, and fed in the Coin, or Colchester beds. No distinct account of the oyster economy, however, is given in the report. There are salt-water ponds for various sorts of sea fish in Foulness island; the fish are caught in weirs on the extensive sandy coasts, and deposited, when plentiful, in these ponds, whence they are dragged for with small nets, as wanted.

Manufactures of woollen have existed from time immemorial in the county; also of sacks, hop bags, calicoes, baize, lime, bricks. Much baize made at Colchester, Coggeshall, and other places, for Spain. A society of agriculture at Chelmsford.

7782. HERTFORDSHIRE. A surface of upwards of 400,000 acres, the north part forming a chalky ridge, which extends across the kingdom in this direction; the general features are rich, woody, and the agriculture various, chiefly tillage; the corn produced equal in quality to any in the kingdom. Ellis, a well known agricultural author, farmed in this county. (*Walker's Report, 1795. Arthur Young's Survey, 107. Marshal's Review, 1818.*)

1. Geographical State and Circumstances.

Climate, dry and healthy.

Soil, chiefly loam and clayey loam, next chalk, and a small part bordering on Middlesex gravel; vales, rich sandy loams, chiefly under pasture, and woods very beautiful. Naturally barren, but rendered fertile by careful cultivation.

2. Property.

Much divided, the county being a favourite one for wealthy persons building villas and other retreats. 7000*l.* a year the largest estate; great part copyhold, which sells here at six years' purchase less than freehold.

3. Buildings.

Hatfield, Cashibury, Ashridge (partly also in Bucks), Gorbamby, Brocket, the Hoo, the Grove, Gilstone, Ware Park, &c. noble mansions. Brown's farm-yard, at North Mims, one of the best in the county. Immense barns at North Mims and Bedfordbury. Gutters to the eaves of farm buildings at Alkenham; wide fattening stalls, with conveniences for giving hay, water, and oil-cake. Cottages seldom with land attached. A moveable sheep-house at Hillhouse, a cumbersome expensive affair, of which plans, sections, &c. are given in the report.

4. Occupation.

Farms small, largest 500 acres; many of the very small farmers who rent 30*l.* a year worse off than day labourers. Sir John Sebright, of Beachwood, a scientific breeder, farms 700 acres, 500 of which are in arable and well cultivated. The Earl of Bridgewater, at Ashridge, farms 500 acres, besides the park of 1080 acres. The Marchioness of Salisbury farms 290 acres, besides the park of 1050 acres, and has made many curious experiments; a prejudice against leases.

5. Implements.

Plough large and unwieldy, with two large wheels, the same as figured in old farming books 150 years ago. One or two threshing machines of Meikle's kind. (*fig. 984.*)

6. Enclosures.

Various, but still some commons and open fields; old fences of mixed species; new ones of thorn; planting well understood, but the cut with the bill made in a direction downwards instead of upwards, as in Berwickshire, by which the stem throws out a brush of small twigs at the wound, instead of a few strong healthy shoots.

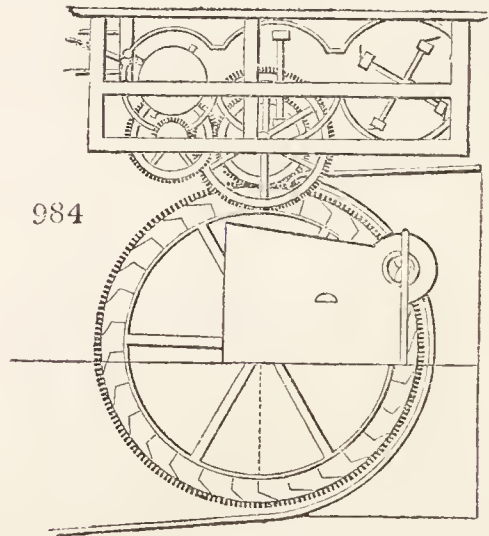
7. Arable Land.

By far the greater part of the county in tillage: crops chiefly wheat, barley, and oats; turnips and clover supposed to have been introduced in the time of Oliver Cromwell: depth of ploughing generally four or five inches. Greg, who has written a tract on managing clay lands without naked fallows, ploughs as deep as the staple will admit. Rotations various, generally with a naked fallow, once in three, five, or seven years, or oftener. Combing or ribbing in use in some places instead of drilling. Turnips cultivated broad-cast, and very poor crops produced; the introduction of turnips in this county attributed to Cromwell, who is said to have settled 100*l.* a year on the farmer who first grew them. Cabbages grown to a large size by the Marchioness of Salisbury, for cows; larger sort preferred. Carrots, parsneps, beets, &c. cultivated by the Marchioness on her experimental farm. Good saintfoin on the chalks. Drilling

corn crops with Cooke's drill practised in various places. Water-cress for the London market, cultivated in the streams at Rickmansworth. Sixty acres of furze for faggots at Ashridge.

8. Grass.

Quantity small, and chiefly a narrow margin near Barnet,



on which hay is grown for the London market; some good meadows on the Stort.

9. Orchards.

Apples and cherries abound in the S.W. corner of the county on farms of from twenty to fifty acres. In ten years after planting, cherry trees begin to bear; produce till the twentieth year, six dozen pounds; when full grown, fifty dozen pounds; price, ten-pence to three shillings a dozen. Caroon, and small black, the favourite sorts. Kentish will not thrive here. None of the apples for cider: orchards kept in grass, but not mowed.

10. Woods.

The copse kind abound in the northern and in many parts of the county; produce faggot wood and hurdles; cut at twelve years; black willow, ash, and hazel, best for hurdles; alders bought by turners and patten-makers. Fine woods, natural and artificial, at the Earl of Clarendon's, the Grove, near Watford. A superb oak at Panshanger, Earl Cowper's; seventeen feet round at five feet from the ground; called the great oak in 1709; on a soil gravelly above, but, doubtless, clay below. The timber in Moor Park of great antiquity, and in a state of decay; many immense pollards; and, on the whole, one of the most forest-like parks near London. Vast oaks and beeches at Ashridge and Beechwood. Beech excels there; also cedars and the oak, ash, larch, spruce, and common pine excellent. Beech sold to turners, chair-makers, and for barrel staves.

11. *Improvements.*

Underdraining clay by numerous parallel cuts filled with straw, wood, or stones general: manuring well understood; much brought from London of every sort; bones, soot, sheep trotters, night soil, oil-cake dust, rags, leather clippings, furrers' clippings, horn-shavings, malt-dust, hair, sticklebacks, &c. Top dressings more frequent than in any other county. Chalk a very common manure on clayey soils; laid on unburned, and left on the surface to be pulverised by heat and rains, or frosts and thaws; then harrowed with a bush harrow, to spread it, and ploughed in. Some irrigated meadows at Rickmansworth and other places; but the frequency of mills is against the process.

12. *Live Stock.*

All the spare clover, hay, and straw carried to London, and manure brought out in return. Sir J. Sebright prefers Suffolk cows and horses, and uses the Wiltshire sheep. A good many house lambs suckled about Rickmansworth, fed with grains and malt-dust in winter. Folding sheep generally approved of. Soiling with clover and tares common. Grey works Suffolk oxen in harness, four to a team. Hon. G. Villiers prefers the Glamorganshire oxen for work; and thinks stall-fed

oxen can hardly be kept too warm; prefers oil-cake for finishing to every thing else; Lady Salisbury has the wild breed of pigs, which fatten to forty-eight stone; feeds on lettuces, which is found to answer well. Stevenson, the bailiff, bred a gardener, which renders him a superior cultivator of green crops. Lord Clarendon feeds deer (7375.) and sells them. Poultry at the Grove kept in wheeled coops about twelve feet long and two and a half wide, boarded on one side and open on the other; these are wheeled up and down the park, and a boy attends them to keep away hawks. In the poultry-yard distinct houses for all sorts of fowls; the roosts so contrived that they may not dung on one another.

13. *Rural Economy.*

Ploughmen generally hired by the year.

14. *Political Economy.*

Good roads; few manufactures excepting plaiting straw, which is very general in the county, especially about Dunstable, St. Albans, Redburn, &c. Weak wheat straw from chalky and white land, and such as grows under trees or near hedges preferred. The plaiters give from two-pence to four-pence a pound for it, and sort it themselves. Much malt made about Ware and Hertford for the London market.

7783. BUCKINGHAMSHIRE. 478,720 square acres of hilly surface, and chiefly of clayey or loamy soil; a considerable part chalky, and the agriculture nearly equally divided between tillage and grass. (*Survey by St. John Priest, Secretary to the Norfolk Agricultural Society, 1810. Malcolm's Survey, 1794. Marshal's Review, 1818. Smith's Geological Map, 1820. Edin. Gaz. 1827.*)

1. *Geographical State and Circumstances.*

Climate. cold and windy on the Chiltern Hills.

Soil. chiefly clay and chalk, with some gravelly loam; Chilterns wholly chalk; vales generally clay.

Minerals. Some ochre, used in painting; a quarry of good marble at Newport, but too deep to be profitably worked; a freestone quarry near Olney.

Water. Numerous rivers and canals for sending produce to market; but often filled with weeds, bushes, and other obstructions, which, after heavy rains, occasion frequent floods: a "commission of waters" proposed by the reporter as a remedy.

2. *Property.*

Some large estates, as those of the Dukes of Bedford, Buckingham, &c.: tenures very various: a description of lands here called yard lands (*virgata terræ*), which entitle the holders to certain rights of common.

3. *Buildings.*

Stowe, and Ashridge (the latter partly in Herts), the first of Grecian, the other of Gothic architecture, the two noblest mansions in the county. Tythingam, Wycombe Abbey, &c. also very good houses, and many others: some good farm-houses, and the dairies very clean and neat; churning often performed by horse machinery: the churns of the barrel kind. Lord Carrington has built some good farmeries, and the Duke of Buckingham some very complete cow-houses. Drake has a good circular pigeon-house, with brick cells or lockers in rows, with shelves before for the pigeons to light upon; fre-

quently white-washed, to keep them free from bugs. A foot bridge at Fawley Court, moveable upon two pivots at its ends, and being heavier on one side than the other, always hangs perpendicularly, excepting when any one walks upon its light side, when the weight of the person keeps it flat: hence it admits the passage of men, but not stock: cottages good, and mostly with gardens attached: some at Brickhill worse than piggeries. Sir J. D. King gives premiums for the best cultivated gardens; also gives clothing and other rewards for good conduct in servitude.

4. *Occupation.*

Size of farms moderate: number in the county 2039; one of 1000 acres, one of 900, four or five between 600 and 700 acres, ten between 500 and 600, twenty-four between 400 and 500, and the rest from 400 down to ten acres; average, 179 acres. Westcar, of Kreslow, a celebrated grazier, occupies 900 acres, of which only between sixty and seventy are arable. Very few leases, and those given with very objectionable covenants. Lord Carrington and other more enlightened proprietors grant leases.

5. *Implements.*

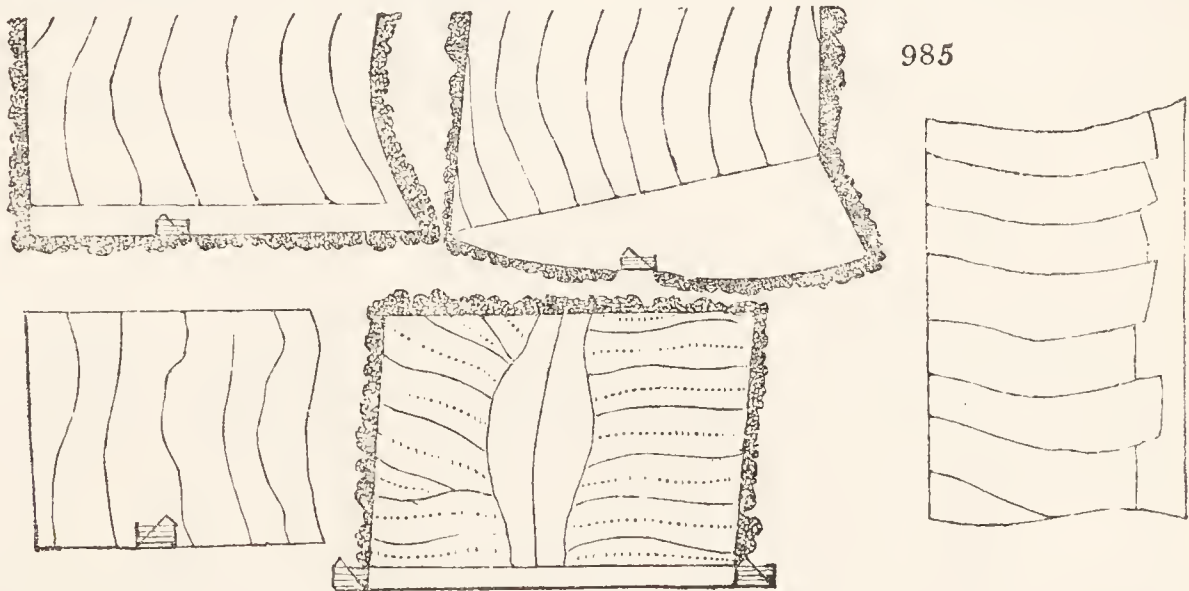
Swing ploughs and four horses in a line common.

6. *Enclosing.*

Has gone on rapidly; old hedges mixed, and with many ash and oak pollards.

7. *Arable Land.*

Ridges high, crooked, with waste spaces between, around, or at the ends (*fig. 985*). Fallow in general every third year,



most common rotation fallow, wheat, beans: chief grains, wheat and barley; beans drilled and hand-hoed: some turnips on the light lands.

8. *Grass.*

Pastures a prominent feature; those in the vale of Aylesbury, especially thence to Bicester, very rich; generally fed, but occasionally mown. Removing ant-hills called banking, a piece of management to which the renters of grass lands are generally bound in their leases. They are removed by skinning, gelding, or gutting, and kept down by rolling; thistles are spudded; size of grass fields from 20 to 300 acres.

9. *Gardens and Orchards.*

Few of either worth notice: cherries are grown at Hackwell Heath, for the London and Aylesbury market.

10. *Woods and Plantations.*

Willow pollards planted round the margins of fields, on soils suitable for hurdle wood. Birch, the most common timber, very abundant; chiefly used for manufacturing chairs: woods constantly full of young plants from the mast, which grow up and succeed those which are felled; thus the same timber on the same soil and surface for ages. At Shardeloes, a beech seventy-five feet from the ground, to the first bough: oak and beech trees in Ashridge Park, containing from three to six loads of timber: very fine beeches at Missenden; mast given to pigs.

11. *Improvements.*

Draining much wanted; well performed on some hogs on the Duke of Buckingham's estates by digging a well and boring in the bottom till the spring was tapped, and then leading it off in an underdrain; paring and burning in general use for bringing grass land to tillage: chalk much used as a manure, sixty or seventy loads per acre, once in twenty-one years, or forty once in twelve years; allowed to lie on the surface for one winter at least before being ploughed in. Only one instance of irrigation worth notice, which is at Cheynies, by a tenant of the Duke of Bedford.

10. *Live stock.*

Cattle kept chiefly for beef and butter, seldom for cheese or work; Hereford oxen preferred, and next the Devon; Holderness cows for the dairy; some prefer the long horned Lancaster, and others the Suffolk; many of the Holderness cows, after being kept a few years, are sold to the London cow-keepers; men are generally the milkers; only one instance found of women performing that operation. Earl of Bridgewater keeps eight teams of Welsh, one of Sussex, and one of Durham oxen, all yoked as horses; five used in the cart, and four in a plough; a few other gentlemen have ox teams; cattle generally fed off in summer; cows kept during winter fed on straw, hay, and oil-cake; little herbage or roots in use; milk

generally kept in flat vessels of lead; some wooden trays, tinned, in use; skimmed every twelve hours; in some few places three times a day; cream from first two skimmings kept by itself; the third skimming makes what is called after-butter; skimming dish, if tin, circular, a foot in diameter, with holes in it, and a handle upon the top of it; butter made twice a week, in churns of the barrel kind, usually turned by a horse; time allowed for the butter to come, an hour and a half; butter made up in lumps of two pounds each, and sent to London in square flat baskets, eleven inches deep, holding from thirty-six to 120 pounds. They have each on three of their sides three marks, the number of pounds the basket holds; a letter, denoting the farmer's name from whom it is received, and the name and residence of the carrier. The baskets and butter cloths are the property of the carrier; all that the farmer has to do is, to carry his butter to the nearest point where the carrier passes, and to make his agreement with his butter-factor in London, and receive monthly, or otherwise, the payment. Quantity of butter made, six pounds per cow per week, at an average, when in good keep, and not nearly dry. Calves generally sold to sucklers; a few suckled in the county, and a few brought up as stock.

Sheep. Culture directed to the fattening of lambs, and the breeds preferred are the Dorset, and next the Gloucester and Berkshire.

Horses generally soiled; five or six put to a plough in many places, and never less than three. A team of asses kept by the Duke of Buckingham for the use of his garden; many used at the potteries at Amersham.

Hogs, an important article on account of the milk from the dairies; breed the Berkshire, and next, the Chinese and Suffolk.

Ducks, a material article at Aylesbury and places adjacent; breed white, and of an early nature. They are bred and brought up by poor people, and sent to London by the weekly carriers. One poor man had before his door a small pit of water, about three yards long and one yard broad: at two corners of this pit are places of shelter for the ducks, thatched with straw; at night the ducks are taken into a house. In one room belonging to this man (the only room he had to live in) were on the 14th of January, 1808, ducks of three growths, fattening for the London market; at one corner, about

seventeen or eighteen, four weeks old; at another corner, a brood a fortnight old; and at a third corner a brood a week old. Ducks six weeks old sold at that time for twelve shillings a couple. Besides the above, there are other persons who breed many more ducks than the person now mentioned, and, as far as it was possible to discover, this person sends 400 ducks in a year to London. Allowing, then, forty persons to send only as many, at an average of five shillings per duck, the return of ducks from Aylesbury alone will amount to 4000*l.* per annum. This return has been magnified into 20,000*l.* per annum.

13. *Political Economy.*

Bye-roads extremely bad and dangerous; difficult to be discovered from mere drift ways; turnpike-roads, not to be commended; canals various and useful; grain sent to London at two shillings per quarter. Box clubs generally established for the poor; no agricultural society in Bucks. Principal manufactures paper and lace.

14. *Miscellaneous.*

In calculating the number of acres, Priest the Reporter tried the mode, first shown by the Bishop of Llandaff, of weighing the portion of paper containing the map; he next took an exact copy of Cary's map upon paper, by tracing its outline, after the map was strained upon a canvass blind at a window. This copy was cut out with great exactness by a sharp pointed knife, and then divided into pieces, which were so neatly laid together, as to form a right-angled parallelogram: another piece of paper was cut into the form of an assumed parallelogram longer than necessary, upon which the pieces of the copy were laid, and cemented by gum-water, so as to fill all parts of a right-angled parallelogram shorter than that assumed; the difference between the assumed parallelogram and that formed by the pieces of the copy of the map, was accurately measured and subtracted from the assumed parallelogram, and the remainder gave 391,040 acres, the measure of the number of acres in Bucks. Thus then we have the number of acres taken from Cary's map, by weight 396,013, by measure, 391,040. From which, if we take an average, we shall probably state it as accurately as it can be found to be, 393,526 statute acres; which, for the sake of round numbers, we will call 393,600 statute acres.

7784. **BEDFORDSHIRE.** An irregular parallelogram of 290,000 acres, not much varied in surface, and for the most part of a clayey soil. The agriculture chiefly directed to the raising of wheat, barley, and beans, but of an inferior description in many respects. Little pasturage; scarcely any market orchards, but good vegetable gardens established at Sandy, on the east of the county, from time immemorial. Great exertions made in every department of culture by the late and present Duke of Bedford, by whom were employed many valuable men in conducting improvements, as Farey, Smith, Salmon, and Pontey. A valuable set of experiments on grasses, conducted by Sinclair under the direction of the present Duke. (*Stone's Bedfordshire, 1794. Batchelor's Bedfordshire, 1808. Marshal's Review, 1818. Smith's Geological Map, 1820.*)

1. *Geographical State and Circumstances.*

Climate, mild, genial, and favourable to the growth of vegetables; rather later than Hertfordshire; prevalent winds S.W.; coldest winds N.E.

Soil, chiefly clay, next sand, and lastly in the southern extremity embracing Herts, chalk. Some of the sands grey silts, and producing nothing but heath, others more loamy, as about Sandy, which is supposed to contain the best garden-ground in the county.

Minerals, some ironstone; limestone abounding with cornua ammonis and other shells, petrified wood, gryphites belemnites; freestone, chiefly lime, at Tatternhoe.

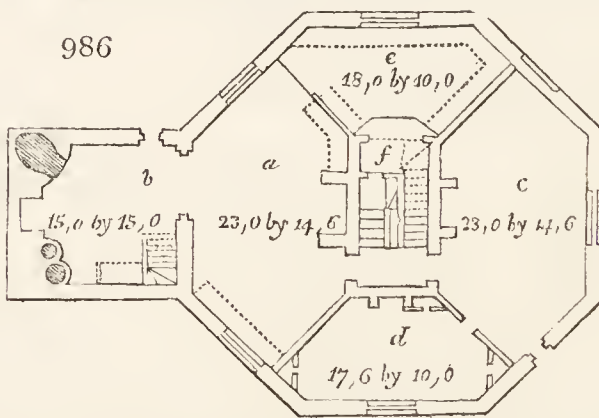
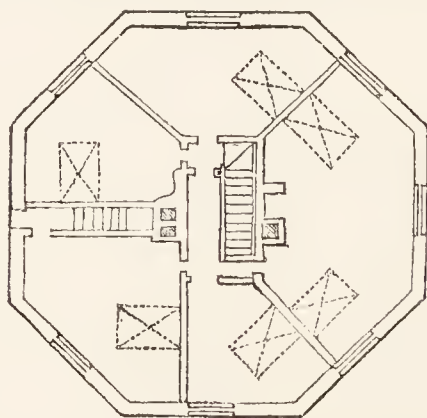
Water. Principal river the Ouse; several mineral springs.

2. *State of Property.*

Duke of Bedford's estates the largest, next Lord St. John's and Whitbread's: united rental estimated at 40,000*l.* a year, Estate managers attorneys and considerable farmers.

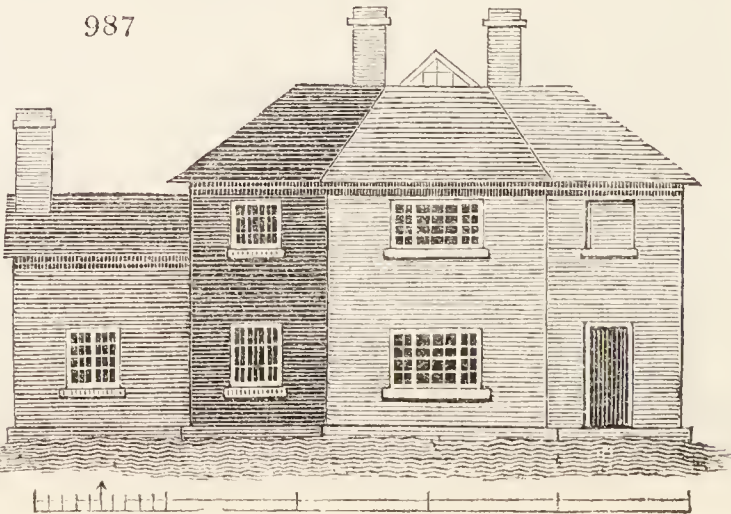
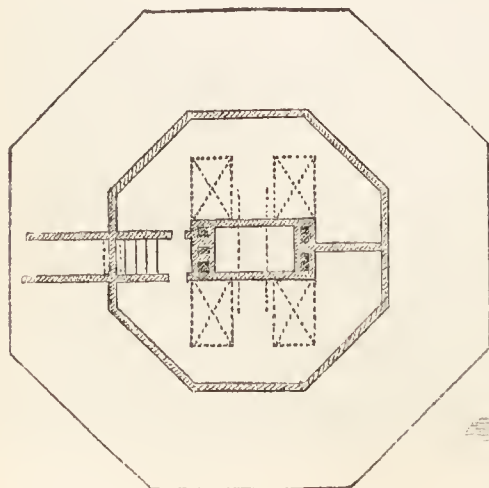
3. *Buildings.*

Several farm-houses were formerly the seats of gentlemen who farmed their own estates. Farm-houses in general badly situated, seldom at the centre of the farms to which they belong, and generally consist of piecemeal erections. Francis, Duke of Bedford, erected an octagonal farm house, on a most commodious plan. (*fig. 986.*) On the ground floor it con-



tained a large kitchen (a), bake and brewhouse, and wash-house (b), a hall or master's room, with a cellar under (e), a good parlour (d), a dairy (e), besides a pantry (f), closets, and

beer and ale cellar under. On the first floor were five, and on the second (*fig. 987.*) two good bed-rooms. The expense of this house on the octagonal plan was 671*l.*; had it been built in the



square form it would have cost 733*l*. It is built of brick, slated, and was designed by Mr. R. Salmon, a well known mechanist, resident at Woburn. The same accommodations on a square plan forms a house more convenient for placing furniture (*fig.* 988.) Wattle and dab, that is, clay plastered on hedge-work of splinters, or on wood frame-work, and also the *Pisé* manner of clay-working, in use in some places, both for farm-houses and cottages. *Pisé* walls found warmer and cheaper than any other, and when whitewashed said to make good cottage walls.

4. Occupation.

Many farms of from 200 to 500 acres; average 150 acres; Duke of Bedford's farms generally of the average size. Farmers much improved by the example of Woburn and the annual meetings. The experiments made by Francis Duke of Bedford were to ascertain the quantities of hay consumed by working oxen; comparison between large and small cattle as to food; comparative value of different foods, &c. Tithes mostly in lay hands; farms held generally from year to year, some on leases of fourteen or twenty-one years.

5. Implements.

Plough of the swing kind, with a wooden board and a wedge nailed on as a mould board, one fixed handle, and a loose one called a plough staff; the whole singularly rude, though in general use throughout the county. Improved forms of all machines introduced by the Duke of Bedford's Northumbrian manager, Mr. Wilson, and other enlightened men. A good straw cutter winnowing machine, a hay tedder, and also an excellent weighing machine, invented by the late Mr. Salmon, an engineer of genius, resident on the Duke's estate, and employed by him as an agent.

6. Enclosing.

Formerly three fourths of the county unenclosed, now chiefly enclosed.

7. Arable Land wretchedly ploughed.

Fallows, which occur on the clays generally once in three years, badly worked. Usual crops are fallow, wheat, beans, or fallow, barley, beans; turnips common on the sands and chalks, sown broad-cast, and hand-hoed. Chicory was tried by the Duke of Bedford, who found it yield ample produce; had twelve acres which, in 1797, kept six sheep per acre from the second week in April till Michaelmas; four and a half kept ten sheep an acre from the second week in April till 22d July, and then seven per acre to end of October. Sheep thrive well and free from diseases.

8. Grass Land.

Of very limited extent, and in many places covered with sedge (*Carex*), and ant-hills.

9. Gardens and Orchards.

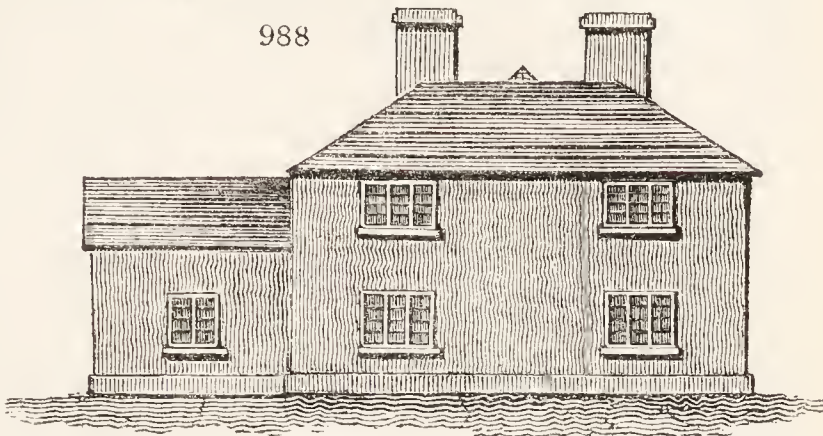
Gardens of Sandy and Girtford long celebrated for the ex-

cellence and abundance of their culinary vegetables. Soil a deep sand, of a yellowish brown colour; products peas, beans, cucumbers, potatoes, parsneps, and carrots, radishes, cabbage plants, and turnips, sent to market in all directions to the distance of sixty miles. Cucumber chiefly to London, and sold at ten and twenty shillings a bushel for pickling. Orchards small. Potatoes, gooseberries, and other small fruits grown in cottage gardens.

10. Woods and Plantations.

About 7000 acres, situated on the slopes of hills on cold marly clays. Various new plantations formed by the principal proprietors, especially the Duke of Bedford. Furze grown on some of the sandy hills, for burning lime. Some fine trees of the silver fir, and others of the genus *Pinus* at Woburn,

988



planted under the direction of the celebrated Miller; a fine beech, figured by Pontey in his *Forest Pruner*.

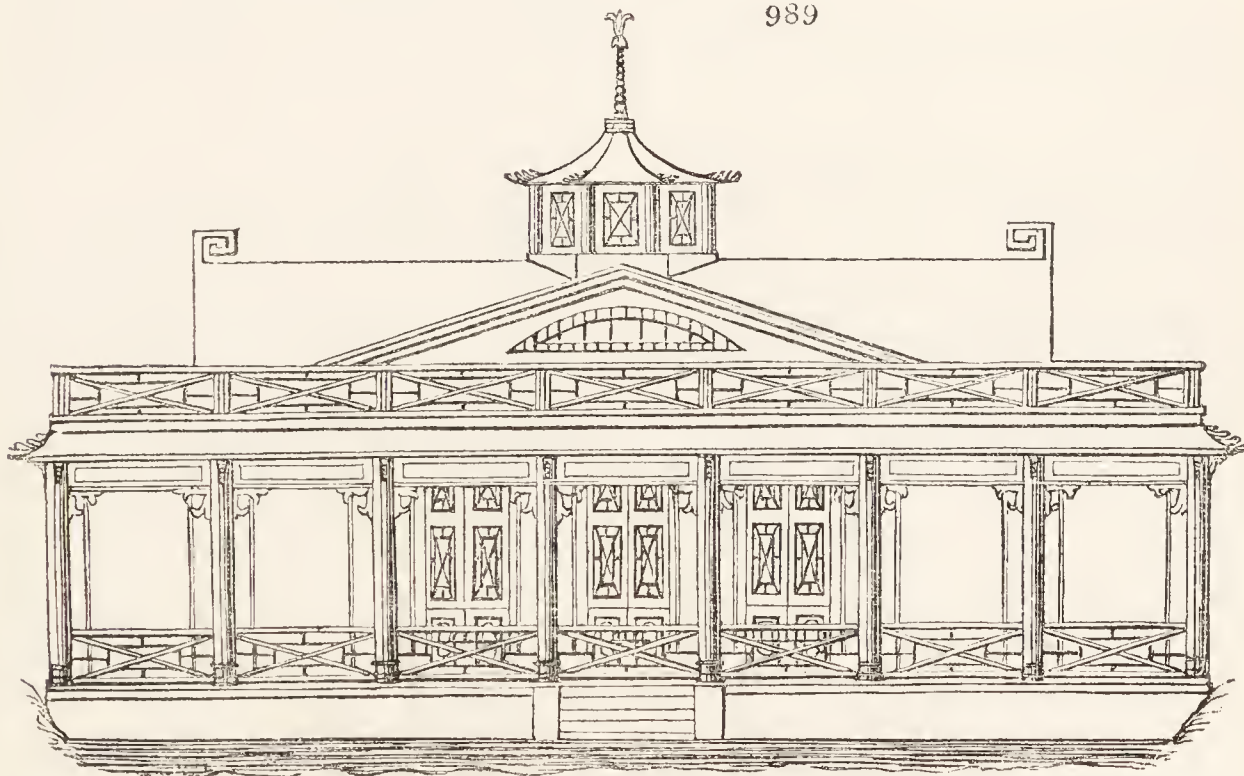
11. Wastes.

Four thousand acres of chalky down at Dunstable, not much any where else.

12. Improvements.

A good deal drained, especially bogs. Elkington's mode said to have been tried with very partial success. Bush and straw-draining attempted on the clayey soils, and the mole plough a good deal used in the furrows. Irrigation introduced by the Duke of Bedford, and various examples are to be found in different parishes on his Grace's estates. Peat is used as fuel, and also burned for the ashes as a manure; ample experiments made on manures, by Dr. Cartwright, at Woburn; but no agricultural experiments on a small scale can be depended on. The dairy at Woburn (*fig.* 989.) is a fanciful structure in the Chinese style; but the plan and arrangement is not well calculated for keeping milk and butter cool and sweet.

989



13. Live Stock.

Cattle a mixed breed of long and short horned Alderney, &c. Some dairying conducted as in Buckinghamshire. Some sheep, but of no particular breed; folding generally practised and approved of; horses a heavy breed from Huntingdonshire; rabbit warrens destroyed as much as possible; geese kept by many from an idea that they preserve the health of the pasturing animals where they feed. Turkeys and pigeons kept before the enclosure in various places, but now much on the decline. Bees kept by a few cottagers and small farmers.

14. Rural Economy.

Husbandry business generally performed by day labourers; though on most large farms a horsekeeper, cowkeeper, shepherd, and kitchen maid hired by the year.

15. Political Economy.

Almost all the cross roads, and many of the main roads, very bad. Grand Junction Canal passes through a part of the

county, and is very useful; fairs and markets various; manufactures chiefly plaiting of straw and lace; children of ten or twelve years of age acquire the art of plaiting, while their mothers sort and bleach the straw. Lace-making a more sedentary employment, and the women and children generally appear sickly. There are school-mistresses for teaching both straw plaiting and lace-making. Begin to learn to make lace at six or seven years of age; do little good for two years, at ten years earn two shillings a week, at sixteen as much as can be made by the business, or nearly six shillings a week; work in summer from six o'clock in the morning till sunset, and in winter from nine till eleven at night; maid servants scarce in consequence, but poor rates kept down. Some rush mats made near the Ouse to the west of Bedford.

Bedford House of Industry.—"The poor in the house are employed in the following manner: A manufacture of coarse baize furnishes employment for all the boys five years of age, and some of the men; the remaining part of the men cultivate

an acre and a half of garden-ground, and weed and keep in order twenty-five acres of sward land attached to the house. The old women spin flax to make linen for the use of the family; the other women (exclusive of those engaged in domestic concerns), and girls above six years old, make thread lace. One-sixth of the earnings of the poor is paid weekly to those who work, by way of gratuity. The Governor of the House of Industry adds, that the above employments have answered the most sanguine expectations of the directors of the establishment."

Many useful benefit clubs.

16. *Obstacles to Improvement.*

Want of knowledge and leases. Mice generally destroyed by

7785. HUNTINGDONSHIRE. A dull flat surface of above 200,000 acres; till Edward the First's time one continued forest. The name of the county is said to be derived from the facility it afforded for hunting. The soil is almost uniformly good, but injured by water; it is chiefly under tillage, but remarkable for no excellence in agriculture. Rape-seed and mustard are more cultivated than in most other counties, and timber more rare. (*Stow's Huntingdonshire*, 1793. *Maxwell*, 1793. *Parkinson*, 1811. *Marshal's Review*, 1813. *Smith's Geological Map*, 1821. *Edin. Gaz.* 1827.)

1. *Geographical State and Circumstances.*

Climate, tolerably healthy, considering that the east part is skirted by fens, and but a small part supplied by water from springs.

Soil. Loam prevalent, but the county every where spotted with roundish patches of clay, sand, marl, fen, moor, or lakes, which, in the map of soils annexed to Parkinson's Report, assumes a very singular appearance.

Water chiefly supplied from ponds; Ouse and Nene the only rivers; the meres are natural ponds, surrounded by reeds and other aquatic plants, and a considerable zone of marsh or bog, according as the soil may be loam or sand. Whittlesea Mere contains 1570 acres, but is not above two feet deep. It abounds with fish and wild fowl.

2. *State of Property.*

Old enclosed lands in the hands of a few proprietors; half the county freehold, the remainder almost all copyhold.

3. *Buildings.*

Farm-houses very inconveniently situated, partly owing to the want of high and dry sites on central parts of farms; some good cottages lately erected as the only means of retaining farm servants for any length of time with the same master.

4. *Occupation.*

Many large farms, though small ones predominate; leases frequent; tithe in kind.

5. *Implements.*

Plough, with one handle, originally from Holland; one wheel, a circular plate of iron which is kept sharp, acts as a coulter.

6. *Tillage.*

Plough, with a pair of horses, or three abreast; two crops and a fallow the common rotation; chief crops, wheat, oats, and beans; rape sown on the fens; lands either once ploughed out of grass, or pared and burned; also on uplands; manured and treated as turnips; seed threshed in the field; straw generally burned, or used for yard fences; wheat succeeds well

7786. CAMBRIDGESHIRE. A flat or little varied surface of 437,040 acres, generally of good soil, and having about one third under tillage; remarkable only for the extent of its fen lands, and their embankment and drainage, both very imperfect. The valley watered by the Cam is called the Dairies, being almost entirely appropriated to dairy farms. Horses are a good deal bred in the county, and also pigeons. (*Vancouver's Cambridgeshire*, 1795. *Gooche's Cambridgeshire*, 1807. *Marshal's Review*, 1813. *Edin. Gaz.* 1827.)

1. *Geographical State and Circumstances.*

Climate. On the uplands dry and healthy, but in the fens the contrary; there the inhabitants suffer most when the fens are driest. Agues have somewhat diminished since the fens began to be better drained.

Soils are very irregularly distributed; loam, clay, and rich black earth extend themselves in irregular masses, and nearly of the same extent. The soil of the fens, is rich, black and deep, and may occupy a third of the whole surface. The rich marshes in the vicinity of Wisbeach consist of a mixture of sand and clay, or silt, a sea-sand, finely pulverised by the action of the waves; and the uplands consist of chalk, gravel, loam, and tender clay. There are no minerals.

Rivers. The Ouse, the Granta or Cam. The Ouse and Nene also cross part of the county, and the old and new Bedford rivers. All these are navigable for barges, and are kept open in frosty weather by ice boats, drawn down the stream by eight horses, four on each side.

2. *Estates.*

Vary much in size. Those of Lord Hardwicke, Duke of Bedford, Duke of Rutland, Sir H. Peyton, and Thorpe, are the largest; greatest part of the county in estates of from 200*l.* to 500*l.* and 1000*l.* per annum; many from 20*l.* to 50*l.* and even 400*l.* a year, occupied by their owners; tenures of all sorts, and a variety of college-land tenures.

3. *Buildings.*

Farm-houses and premises in general bad and inconvenient; lath and plaster, or clay and wattle, the common materials, and clunch or clay walls in general use. Jenyns, of Bottisham, has adopted Arthur Young's plan of building stacks on frames, which run on an iron railway, and are pulled into the barn, where they are forked on to the platform of the threshing machine. Cottages "wretchedly bad," except a few built by Lord Hardwicke, and some other gentlemen.

4. *Occupation.*

Farms from 20 to 100 acres; many from 100 to 1000, but few exceed the latter number; tithes taken in kind in many places.

5. *Implements.*

Ploughs, with a sharp iron wheel, or running coulter, as in Huntingdonshire. Shepherd, of Chippenham, has invented a variety of implements. Some threshing machines, and the best Lothian implements, at Lord Hardwicke's. The *Ely bear roller* is an iron roller, with a number of pieces of iron like small spades fixed into it. It is used in the fenny districts for cutting up the weeds, which choke up the slow running rivers. The horses walk along the bank, and draw it several times up and down the river. The weeds are thus rooted up, and carried down the stream by the first flood.

professional rat catchers; some farmers keep ferrets for the rats. Larks destroy a great deal of new sown wheat. They, with other birds, are very abundant in Bedfordshire, especially about Dunstable, where they are caught in traps, in quantities for the London market. Wire-worms supposed to be increased by artificial grasses.

17. *Miscellaneous.*

An agricultural society founded by the Duke of Bedford in 1801; various premiums offered and paid, to the extent of 100*l.* a year in some years. Cheap publications on agriculture, it is thought, would be a considerable means of improvement.

after rape; hemp sown in a few places; mustard cultivated with great success: sometimes pays 40*l.* an acre on land worth not more than 50*l.*, but very uncertain. Parkinson thinks hemp, flax, rape-seed, and mustard, should be encouraged, as they enrich the farmer, and are all good preparatives for wheat. The only way, he says, to enrich the soil, is to enrich the farmer first.

7. *Grass.*

Some good meadows on the Ouse and Nene; the pastures lie remote from the farm buildings, but are in general rich, though neglected; require to be pared and burned, and brought under aration.

8. *Woods and Plantations.*

A good many pollard willows in the fens, and some osier plantations.

9. *Improvements.*

Great want of a general county drainage, such as that of the Bedford level, in the adjoining counties of Lincoln, Cambridge, and Northampton. The advantages of such a drainage is ably pointed out by Parkinson. Embankments very extensive, and the soil being in general a loose porous sand, puddle walls are generally made in the middle of the mound.

10. *Live Stock.*

Stilton cheese, now chiefly made at Little Dalby, in Leicestershire; is no longer made at Stilton, though it is supposed to have been originally made there about 1720; or, according to some, by a Mrs. Orton, in 1750. A good many horses bred, and a mixture of Lincoln and Leicester; folding sheep much practised. No fewer than 271 pigeon-houses in this county, and a few bees; one gentleman cultivates rabbits.

11. *Political Economy.*

Bad roads; a lace manufactory at Kimbolton; a paper mill at St. Neots; two sacking manufactories at Standground; an agricultural society at Kimbolton.

6. *Arable Land.*

Ploughed and cultivated in general as in Huntingdonshire; hemp is cultivated more extensively; flax is grown, and mustard, near Wisbeach and Outwell; a few lentils, as in Huntingdonshire, but are considered of less value than tares. The reporter says, a second crop of mustard is obtained by what shells from the first, and that mustard springs up in land where it has not been cultivated for upwards of a century. Woad is in cultivation, and for every forty acres a woad mill, it is said, is required. No crop pays equal to the reed, which requires no culture but cutting and bunching; owing to the improvement of the fens, they are now becoming scarce. Whiteseed (*Poa aquatica*), or fen hay, is produced on many parts of the fen lands, and even on such parts as have been dug for peat. The land is inundated till the crop appears above the water, and then, wherever it can be effected, it is let off; in other cases the grass grows to a great height in the water, is mown twice in the season, and often produces two tons per acre each time. The hay is esteemed valuable for cows; causing them to produce much milk, and, it is said, giving the particular flavour to Cottenham cheese.

7. *Grass Lands.*

Extensive; some under no management, and of little value; others very productive, both as hay and feeding lands. In the district called the Wash, they will carry from one to two bullocks, and from five to twelve sheep per acre fed the greater part of the year.

8. *Gardens and Orchards.*

Good market and fruit gardens at Ely, Soham, Wisbeach, &c. which supply Lynn and various places, by water carriage, with apples, cherries, and vegetables.

9. *Woods and Plantations.*

Some young plantations. The Rev. G. Jenyns, of Bottisham, "does not cut off the tap roots of oaks in the usual manner, and finds they thrive faster." (That he is mistaken, see 3927.) Osiers are grown in various places for the basket makers, and found to pay as well as any crop.

10. *Wastes and unimproved Fen.*

In 1794, 158,500 acres.

11. *Improvements.*

In no part of the island draining and embanking so much wanted as in the fens of this county.

The former state of the fen lands, and their degradation to their present state, is given at length in the report, chiefly from a pamphlet by Lord Hardwicke. It was the opinion of Atkins (a commissioner of sewers in the reign of James I., 1604) that

these fens (a space of upwards of 280,000 acres) were once "of the nature of land-meadows, fruitful, healthy, and very gainful to the inhabitants, and yielded much relief to the high-land counties in time of great droughts." Sir W. Dugdale (who was born 1605, and died 1686) was of the same opinion, adding as a proof, "that great numbers of timber trees (oaks, firs, &c.) formerly grew there, as is plain from many being found in digging canals and drains, some of them severed from their roots, the roots standing as they grew, in firm earth, below the moor."

On deepening the channel of Wisheach river, in 1635, the workmen, at eight feet below the then bottom, discovered a second bottom, which was stony, with seven boats lying in it, covered with silt. And at Whittlesea, on digging through the moor at eight feet deep, a perfect soil was found with swards of grass lying on it, as they were at first mown. Henry of Huntingdon (who lived in the reign of Stephen, 1135), described this funny country "as pleasant and agreeable to the eye; watered by many rivers which run through it, diversified by many large and small lakes, and adorned by many woods and islands." And William of Malmesbury (who lived in the first year of Henry II., 1154) has painted the state of the land round Thorney in the most glowing colours: he says, "it is a very paradise, in pleasure and delight it resembles heaven itself; the very marshes abounding in trees, whose length without knots do emulate the stars." "The plain there is as level as the sea, which, with the flourishing of the grass, allureth the eye; in some parts there are apple-trees, in others vines." It appears then, on the authority of the authors quoted, that the fens were formerly wood and pasture. The engineers were of opinion that the country in question, formerly meadow and wood, now fen, became so from partial embankments preventing the waters from the uplands going to the sea by their natural outfalls; want of proper and sufficient drains to convey those waters into the Ouse; neglect of such drains as were made for that purpose; and that these evils increased from the not embanking the river Ouse, and the erection of sluices across it preventing the flux and reflux of the sea; the not widening and deepening, where wanted, the river Ouse; and from not removing the gravels, weeds, &c. which have from time to time accumulated in it.

The first attempt at draining any part of the fens appears to have been made in the time of Edward I. (1272, &c.); many others with various success followed. The famous John of Gaunt (or Ghent, who died in 1395), and Margaret, Countess of Richmond, were amongst the draining adventurers; but Gough, in his addition to Camden, says "the reign of Elizabeth may be properly fixed on as the period when the level began to become immediately a public case. Many plans were proposed and abandoned between that time and 1634, when King Charles I. granted a charter of incorporation to Francis Earl of Bedford, and thirteen gentlemen adventurers with him, who jointly undertook to drain the level, on condition that they should have granted to them, as a recompense, 95,000 acres (about one third of the level). In 1649, this charter was confirmed to William Earl of Bedford, and his associates, by the Convention Parliament; and in 1655, the level being declared completely drained, the 95,000 acres were conveyed to the adventurers, who had expended 400,000*l.*, which is almost 4*l.* 4*s.* per acre on the 95,000 acres, and about 1*l.* 8*s.* on the whole breadth, if the whole level contain 285,000 acres, and it is generally supposed to contain 300,000 acres. In 1664, the corporation called "Conservators of the great level of the fens" was established. This body was empowered to levy taxes on the 95,000 acres, to defray whatever expenses might arise in their preservation; but only 85,000 acres were vested in the corporation, in trust for the Earl of Bedford and his associates; the remaining 12,000 were allotted, 10,000 to the King, and 2000 to the Earl of Portland. At first the levy was an equal acre tax; but upon its being deemed unjust, a gradual one was adopted, which is now acted upon. In the year 1697, the Bedford level was divided into three districts, north, middle, and south; having one surveyor for each of the former, and two for the latter. In 1753, the north level was separated by act of parliament from the rest. In addition to the public acts obtained for draining the fens, several private ones have been granted, for draining separate districts with their limits, notwithstanding which, and the vast sums expended, much remains to be done; a great part of the fens is now (1806) in danger of inundation: this calamity has visited them many times, producing effects distressing and extensive beyond conception, indeed many hundred acres of valuable land now drowned, the misfortune aggravated by the proprietors being obliged to continue to pay a heavy tax, notwithstanding the loss of their land."

The interior drainage of the fens is performed in most places by windmills, which are very uncertain in their effects. Steam has been tried, and there can be no doubt would be incomparably preferable, as working in all weathers.

Embanking may be considered a necessary accompaniment of draining on the fen-lands. The fens are divided into three large levels, and each of these levels are subdivided into numerous districts by banks; but as these banks are made of fen-moor, and other light materials, whenever the rivers are swelled with waters, or any one district is deluged, either by rain, a breach of banks, or any other cause, the waters speedily pass through these bright, moory, porous banks, and drown all the circumjacent districts. The fens have sometimes sustained 20,000*l.* or 30,000*l.* damage by a breach of banks; but these accidents seldom happen in the same district twice in twenty years; the water, however, soaks through all fen banks every year in every district; and when the water mills have lifted the waters up out of the fens into the rivers in a windy day, a great part of the water soaks back through the porous banks in the night upon the same land again. This water that soaks through the bank, drowns the wheat in the winter, washes the manure into the dykes, destroys the best natural and artificial grasses, and prevents the fens from being sown till too late in the season. This stagnant water, lying on the surface, causes also fen agues, &c.; thus the waters that have soaked through the porous fen banks have done the fertile fens more real injury, than all the other floods that have ever come upon them. The remedy for the soaking through of the water is obviously that of forming a puddle wall in the middle, which appears to have been first thought of among the fen bank-makers by Smith of Chatteris, a professed embanker, who thus describes his mode of putting a vertical stratum of puddle in

old mounds: "I first cut a gutter, eighteen fathoms wide, through the old bank down to the clay (the fen substratum being generally clay); the gutter is made near the centre, but a little on the land side of the centre of the old bank. The gutter is afterwards filled up in a very solid manner with tempered clay; and to make the clay resist the water, a man in boots always treads the clay as the gutter is filled up. This plan was tried last summer (1794), on a convenient farm, and a hundred acres of wheat were sown on the land. The wheat and grass lands on this farm are now all dry, whilst the fens around are covered with water. This practice answers so well on this farm, that all the farmers in the parish are improving their banks in the same manner, and some have begun in adjacent parishes."

With respect to *embanking from the sea*, Vancouver is of opinion, that the ground ought to be covered by nature with samphire or other plants, or with grass, before an attempt is made to embank it; there is particular danger in being too greedy. "If the sea has not raised the salt marsh to its fruitful level, all expectation of benefit is vain, the soil being immature, and not ripened for enclosure; and if, again, with a view of grasping a great extent of salt marsh, the banks or sea wall be pushed further outwards than where there is a firm and secure foundation for it to stand upon, the bank will blow up, and in both cases great losses and disappointments will ensue."

Paring and burning is every where approved of, and considered the *sine qua non* of the fen district, in breaking up turf. Without it corn crops are destroyed by the grub and wire-worm.

Irrigation Col. Adeane, of Barbraham, has 500 acres of meadows which have been irrigated from the time of Queen Elizabeth. "Pallavicino, who was collector of Peter's pence in England, at the death of Queen Mary, having 30,000*l.* or 40,000*l.* in his hands, had the art to turn Protestant on the accession of Queen Elizabeth, and appropriated the money to his own use; he bought with it an estate at Barbraham, and other lands near Bournbridge; and procuring a grant from the crown of the river which passes through them, was enabled legally to build a sluice across it, and throw as much of the water as was necessary into a new canal of irrigation, which he dug to receive it in the method so well known, and commonly practised in Italy long before that period. The canals and the sluices are all well designed, and are the work of a man evidently well acquainted with the practice; but in taking the waters from them, for spreading it by small channels over the meadows, there does not seem to be the least intelligence, or knowledge of the husbandry of watering. No other art is exerted but that merely of opening in the bank of the river small cuts for letting the water flow on to the meadows always laterally, and never longitudinally, so necessary in works of this kind. The water then finds its own distribution, and so irregularly, that many parts receive too much, and others none at all. From the traces left of small channels in different parts of the meadows, it would appear that the ancient distribution formed under Pallavicino is lost, and that we see nothing at present but the miserable patch-work of workmen ignorant of the business. Irrigation has not spread from this example, but might be extensively practised on the banks of all the rivers."

12. Live Stock.

Cattle a breed peculiar to the county; but some of all sorts. Butchers give more for a Cambridge calf than a Suffolk one, fancying the former whiter veal. The Cottenham cheese ascribed to the excellence of the grass, in great part *Poa aquatica*.

The *cow system* consists chiefly in suckling of calves and making of butter; there is not much cheese made, except the noted ones of Soham and Cottenham. The suckling season is from Michaelmas to Lady-day. It requires, on an average, two cows to fatten a calf. The cows, when at a distance from home, are milked in the pasture, and the milk brought home by a horse or ass, in tubs, slung across: women could not do this work, the travelling being, after the least rain, very bad, even when there is no water to go through. The butter is sold rolled up in pieces of a yard long, and about two inches in circumference; this is done for the conveniency of colleges, where it is cut into pieces, called "parts," and so sent to table; its quality is nowhere excelled.

Bullocks of various kinds fattened on grass, and when not ready in autumn, put up and finished on corn or oil-cake. Col. Adeane buys in London at a falling market, and keeps till a rising one before he sells.

Sheep chiefly as in Huntingdonshire; some Norfolks and South Downs; folding on the uplands.

Horses of the cart kind much bred, and considered an article in which the county excels; they are very large and bony; black; with long hair from the knee to the fetlock trailing on the ground. A cart stallion has cost 255 guineas, and his colts have sold for sixty guineas. Horses kept in the stable throughout the year, at a great expense, because on dry food; herbage plants, artificial grasses, and roots being neglected, and no soiling practised.

The deer in Wimpole Park attacked by a singular disease, a sort of madness; the diseased animal begins by pursuing the herd, then sequesters himself, breaks his antlers against the trees, and gnaws large pieces of flesh from his sides, &c. becomes convulsed, and soon expires.

Pigeon-houses on almost every farm; kept in a great measure because if any one were to give them up, he would be obliged to keep the pigeons of others; destroy thatched roofs, and oblige every farmer to sow more seed than he otherwise would; produce sent to London and other parts; often 100 dozen per annum from one pigeonry; dung highly prized.

13. Rural Economy.

Peat, sedge, or thin turf, and dried cow-dung used as fuel. The cow-dung is spread on grass, about an inch and a half thick, and cut into pieces, eight or twelve inches square; there it lies till dry.

14. Political Economy.

Roads miserably bad; canals or navigable cuts in the fens in all directions; a few fairs; a pottery at Ely for coarse ware; excellent white bricks made there, and at Chatteris and Cambridge; lime burned at various places.

7787. **SUFFOLK.** A crescent-like flat surface of 800,000 acres, the soil chiefly in patches of clay, poor sandy soil, and rich loam, and the agriculture directed to the growing of corn. The county is, however, famous for its breed of cows, horses, and hogs, and it is one of those in which carrots are a good deal grown. One of the largest sheep fairs in the kingdom is held at Ipswich, where it is said as many as 150,000 or 200,000 sheep and lambs have been exposed for sale. The celebrated Arthur Young was a native yeoman of the county, and farmed his own estate near Bury. (*Young's Suffolk*, 1810. *Smith's Geological Map*, 1819.)

1. Geographical State and Circumstances.

Climate. One of the driest in the kingdom; the frosts severe; and the N. E. winds in spring, sharp and prevalent.

Soil. The predominating a strong loam on a clay-marl bottom in the centre of the county; chalk also occurs extensively as a substratum; a zone of sand stretches along the coast; and some sand and fen land in the north-west angle; no minerals.

2. Property.

Chiefly in the hands of rich yeomanry, who cultivate their own estates of from 100*l.* to 400*l.* a year; one estate of 1500*l.* a year; and two or three of 10,000*l.*

3. Buildings.

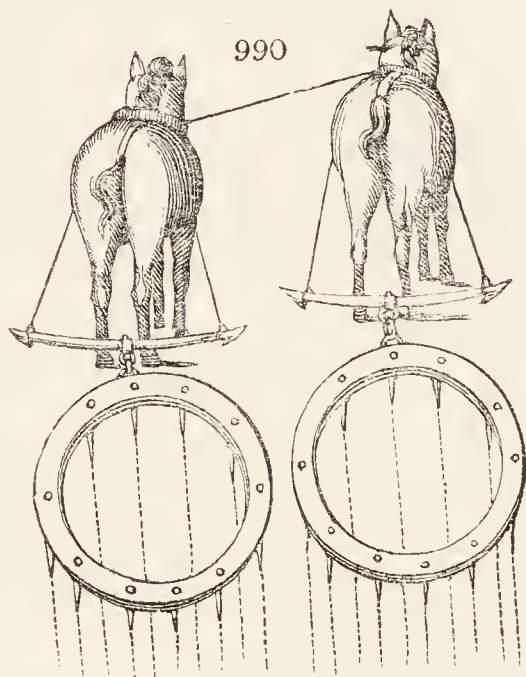
Great erections have been made for the convenience of men of large fortunes; but not so many for those of smaller incomes; farm-houses improved, but still inferior to what they might be; often of lath and plaster, and wanting requisite repairs; barns uselessly large; cottages in general bad habitations; the door generally opens from the external air into the living room; reparation bad, and the deficiency of gardens general.

4. Occupation.

Farms generally large; some from 20*l.* to 100*l.* a year; generally from 150*l.* to 900*l.*; the largest on the sandy districts. Leases for seven, fourteen, and twenty-one years; but little land held at will.

5. Implements.

The Suffolk swing plough, though known as one of the best of the old English swing ploughs, is now giving way to improved forms; various threshing machines, and other improved implements introduced; circular harrows (*fig.* 990.) were used on the farm of the late celebrated Arthur Young.



6. Enclosures.

Suffolk one of the earliest enclosed counties in England; a few recent enclosures.

7. Arable Land.

Plough, with two horses, one acre a day on stiff soils, and one and a quarter to one and a half on sands; ploughmen skilful, and subscribe prizes among themselves for such as draw the straightest furrow, &c. Besides all the common crops, a larger proportion of peas grown than is usual in most counties. Hops, cabbages, carrots, lucerne, chicory, and hemp, are grown in a few places. The culture of carrots is, of course, confined to the sandy districts, and that of rape for seed, and of hemp, to the fenny angle of the county. A. Young seems to have been the chief cultivator of chicory, having had "ninety acres of it for sheep." Hemp is grown both by cottagers and farmers, and for the seed as well as fibre, but never on a large scale; five acres is the greatest breadth to be met with.

8. Grass.

Pastures coarse and not extensive; both these and meadows badly managed, overrun with mole and ant hills, bushes, tufts of bad grasses, weeds, &c. Hay-making badly performed.

7788. **NORFOLK.** A flat surface of 1,288,000 acres, chiefly of a loamy and sandy soil, and devoted to the growth of corn, and the fattening of cattle and sheep. This county has acquired celebrity for its general culture, and especially for that of turnips and clover. It displays a great variety of practices, and abounds in wealthy farmers. It is also noted for the estate of Coke, a true and consistent patriot for upwards of half a century, the most munificent of landlords, and the greatest friend to farmers. Norfolk, in short, was formerly reckoned the finest county in England for agriculture, as Northumberland is at present. Mackie's nursery at Norwich, the property and under the direction of a lady, is one of the most extensive and best managed of provincial nurseries. (*Kent's Norfolk*, 1795. *Young's Norfolk*, 1801. *Marshal's Review*, 1813. *Dr. Rigby's Holkham, its Agriculture, &c.* 1819. *Smith's Geological Map*, 1819. *Edin. Gaz.* 1827.)

9. Gardens and Orchards.

Garden walls built of the width of a brick, by making them wavy. (*Encyclopædia of Gardening*, 1567.)

10. Woods and Plantations.

Few, and pay badly; but large oak timber formerly produced in the clay districts.

11. Improvements.

Wheat substituted for rye. Draining much practised on the clays; bushes, straw, or stubble used for filling them; claying and marling the sands practised, but sand laid on clay found of no use, or marl on clay, according to the old adage —

Marle clay, throw all away;
Marle sand, and buy land.

Some workmen procured from Gloucestershire to execute irrigations in the manner of that county.

12. Live Stock.

In cows, horses, and hogs, Suffolk excels. The Suffolk breed of cows spread over the whole county. To keep the breed polled, horned calves are never reared, but sold to the sucklers. Cows in prime give eight gallons of milk per day, and great part of the season six gallons; best milkers red brindle, or yellowish cream coloured; not always the best feeders. Often fed in winter with cabbages. A point of bad management is, that the bulls, when three years old or thereabouts, are either sold or castrated for fattening, by which means, when a good stock-getter is thought to be discovered, when searched for he is no more; thus no improvement can be made in the breed, but by accident. Cows are allowed to range over turnip fields and eat where they please, and often the same as to cabbages. In some cases they are tied to posts in the open field, littered, and the vegetables brought to them: both barbarous modes of management. Dairy management not particularly good; women in general the milkers; milk generally seven or eight cows an hour; one for a wagger milked thirty in three hours. Quality of milk depends not only on the food, but on the condition of the cows as to health and fatness. Chafing dishes of charcoal kept in the dairies during frost, but the cream does not rise so well. Butter generally salted in firkins.

The sheep used are of various breeds, and the practice of folding is universal.

Horses of the best variety found on the sandy soils, as about Lowestoff, Woodbridge, Orford. About the middle of last century, a considerable spirit of breeding, and teams drawing against teams for large sums, existed. The old breed were ugly, with slouching ears, ill shaped head, and low in the fore end; a great carcass, short legs and short back; they could only walk and draw, and no more trot than a cow; of late, by aiming at coach horses, the breed has become handsomer, and one of the best for draught in England. In the east district, horses are turned out of the stable in winter at night, about eight o'clock, into a yard well littered with straw, with plenty of oatens and barley straw to eat, but no hay; so treated, they are found to keep free from diseases, and work several years longer than if kept constantly in stables.

The hogs fatten early and at little expense, but are not great breeders.

Rabbits. Many warrens in the sand district; one at Brandon returns 40,000 rabbits in a year; twenty rabbits per acre usual produce; carcass defrays rent and taxes, and the skin profit; so that no mode of farming can be more profitable to the occupier.

Poultry. Turkeys generally cultivated, but chiefly for home use.

Pigeons abound on the borders of Cambridgeshire.

13. Political Economy.

Roads very good; made with flints and gravel; some canals. Ipswich and Bury excellent markets; a good deal of fishing on the coast; spinning and combing wool, and spinning and weaving hemp, among the cottagers. Says and silk manufactures at Sudbury. Various hundreds in this county incorporated by charter for erecting houses of industry for the poor; they manufacture netting for the fishers, spin, &c., and cultivate a few acres of land; they are admirably kept and managed, and the poor live like the pensioners in Chelsea college; but these houses of industry have little effect in lowering the poor rates. The best managed are of very expensive tendency, and of equivocal effect as to comfort and morality. Those badly managed are nurseries of idleness and vice, attended with great discomfort and expense. Marshal considers them as the grave of morality and independent policy, and as we are informed, by a gentleman who has been a director of one of them for many years, with perfect truth.

14. Obstacles to Improvement.

The great abundance of game in the county is such, that instances are given of corn having been injured to the extent of half and three fourths of its value by hares and pheasants, which are common every where, and on the sand district more especially.

An agricultural society, called the Milford society, meets alternately at Milford and Bury.

1. *Geographical State and Circumstances.*

Climate colder and more backward than Suffolk; N. E. winds severely felt in spring; salubrity of the air affected by the fens of Lincolnshire and Cambridgeshire to the extent of 5 or 600,000 acres, which lie on the west side of the county.

Soil. A sandy loam or sand; Kent says, similar and equal in value to that of the Austrian Netherlands. There is a small patch of silt or warp clay on the borders of Lincolnshire, and of rather stiffer clay on the borders of Cambridgeshire.

Water. The sea and rivers for navigation; watering ponds for cattle made at Holkham, each to serve four enclosures, forty-two feet square at bottom, twelve and seven feet deep, bottom and sides well covered with sand; within a yard of the top, the clay two feet thick, and paved with bricks set on edge. These ponds made by men from Gloucestershire, at two and sixpence per superficial yard. To divide the ponds for four fields, a large stone with a hole wrought in it to receive a post is necessary at the centre, and the post has mortices to receive rails from the sides.

2. *Property.*

Estates of all sizes; one of 25,000*l.* a year; one of 14,000*l.*; one of 15,000*l.*; two of 10,000*l.*; many of 5000*l.* Land sells currently at thirty years' purchase. Tenure by freehold three fifths, church, collegiate, and corporate estates one fifth, and copyhold under lay lords one fifth.

3. *Buildings.*

Some noble seats of proprietors. Kent says farm buildings are on too large a scale; "they are always crying out for barn-room, though wheat is preserved cheaper and better on stables;" barns on a farm of 100*l.* a year that have cost 300*l.* Coke has expended above 100,000*l.* on farm-houses; barns at Holkham 120 feet long by 30 broad and 30 high, surrounded with sheds for sixty head of cattle; walls of fine white brick, and roof of blue slate. At Lyderstone an immense barn of Coke's, containing the crop of 140 acres. Seven men necessary on the goff or mow, at the unloading of every waggon, and dare not venture to tread the corn for fear of bursting the barn; farmers fond of immense barns. In building, Coke has substituted milled lead for ridge tiles to the roofs; copper wards to all locks; front edges of mangers are rollers covered with tin; mangers themselves plated with iron; bottoms of the stall fences of Penryn slate. In building walls not to be roofed, they are drawn in to a brick's length at top. Lime-wash used as a preservative to boards, walls, &c.: it is composed of lime fresh from the kiln, and clean sharp sand, mixed with hot water, and laid on hot; stirring it up so as always to lay on sand with the lime. An excellent plan. At Holkham a brick manufactory, where bricks of all forms are made, and common bricks are cut, five parts in six, through in various directions, so as to give half and quarter bricks, angles, &c., without breaking and waste. This is one of the most complete manufactories in the kingdom. At Belwy a capital farmery, labourers' cottages, and gardens. Sharp clean sand dashed on new paint found to answer the end of imitating stone, &c. A. Young did not see a good farm-yard in the county.

Cottages much wanted; some built of flint-work.

4. *Occupation.*

Farms large on the dry soils, and smaller on the wet ones; 2000 acres arable, the largest measuring from 400 to 600. Farmers famous for their improvements, excellency of their management, and the hospitable manner in which they live, and receive their friends and strangers. The farming-mind of the county has undergone two revolutions, one between 1750 and 1760, when great improvements were made; and the next about 1790, when drilling began to be introduced. Coke began to promote farming; and the South Down sheep were introduced about that time. The great improvements for seventy years past effected in consequence of twenty-one years' leases. The advantages of leases ably advocated by Kent. Coke adheres steadily to this term, while some others are reducing it to seven and nine years.

5. *Implements.*

For more than half a century these remained stationary; now improvements making; Norfolk plough has a high-pitched beam, wheels near to the share, and is reckoned lighter than most wheeled ploughs.

6. *Enclosures.*

Many since middle of eighteenth century. In planting hedges on a loamy soil, the plants being laid in, and the bank over them raised to the usual height, the face of it, and also of the ditch, for one foot or more below the original surface is plastered over with clayey stuff taken out of the bottom of the ditch, to the thickness of two or three inches, or more about the sets. The advantage of this plan is, that this loamy puddle, from the bottom of the ditch, is without the seeds of weeds itself, and by its compactness excluding the air from these in the mould below, it prevents them from germinating;

7789. OXFORDSHIRE. An irregular, inland, elevated surface, of 450,000 acres, chiefly in aration, and in a very backward state as to agriculture. There are rich grass lands, subjected to the same dairy management as in Buckinghamshire, and some natural wood lands. The principal agriculturist and patriot of the county is Fane, of Wormsley. (*Davis's Report*, 1794. *Arthur Young's Oxfordshire*, 1809. *Marshal's Review*, 1813. *Smith's Geological Map*, 1823.)

1. *Geographical State and Circumstances.*

Climate cold and bleak. On the Chiltern hills, cold, moist, and foggy.

Soil in three great divisions, red land, stonebrash, and chiltern, or chalky hills; the basis of all these soils is calcareous; there is also a considerable portion of loamy soil.

2. *Property.*

Few large estates; church tenures very common; one estate of 20,000*l.* a year, one of 12,000*l.*, one of 7000*l.*, one of 5000*l.*, and so on.

3. *Buildings.*

Blenheim, the noblest in England; Maylands' house at Broadeaton, recorded by Young as a model for houses, which cost about 20,000*l.* building. In farm buildings the best thing is the coped stone rick and granary stands; farm buildings generally of stone, covered with stone slate; wretchedly contrived, and badly executed, in most parts of the county. Gardens to most of the cottages. Bishop of Durham has built some very comfortable ones at Mungewell.

the consequence is, hedges planted in this manner require little or no weeding for several years.

7. *Arable Land.*

Plough with two or four horses very shallow; carefully preserve the hard basis formed by the sole of the plough, which is called the *pan* of the land; breaking this up is said to let down the riches into the hungry subsoil, &c. Culture of turnips erroneously stated by Kent to have been introduced from Hanover by Townsend, in the reign of George I.;—double-s has increased since that period. Clover very general, and wheat on the clover ley; turnips all broadcast, or if drilled, never on ridgelets, but on the flat surface; rotations good, such as turnips, barley, clover, wheat, &c. Turnips fed off with sheep, or given to cattle in stalls, or the open yard; sometimes carted on the sown wheats in February, and eaten off them by sheep or bullocks, the soil being very dry and loose; clover eaten off, or mown for soiling or hay;—most generally eaten off by ewes and lambs. Wheat dibbled in some places, a practice which originated in this county, and has scarcely been adopted in any other. Carrots not so much cultivated as in Suffolk; a good deal of mustard from March to Wisbeach; on the rich black lands, four crops of mustard taken in succession, and then wheat; produce three to four quarters per acre. Hemp and flax cultivated in the spots of ground belonging to houses of industry, and in some other cases, but to no extent. Saintfoin not much cultivated; Coke had 400 acres. Lucerne at a few places; mangold wurzel introduced by Sir Mordaunt Martin, who continues to cultivate it. Drilling and dibbling of wheat and peas generally practised on the sandy soils. Coke drills all his corn. Arable culture, in every department, greatly improved since 1790.—A paper, by Kent, entitled *Fallowing exploded*, has been justly condemned by Marshal, and other men of more general experience in culture: his notions of shallow ploughing, and continual tillage and cropping without rest, most erroneous, and contrary to experience.

8. *Grass.*

Very little of natural turf in the county; transplanting turf recently introduced. (5715.)

9. *Gardens and Orchards.*

Orchards to most of the farm-houses; some public ones near the large towns. Norfolk beefin an excellent apple, and much used for baking dry in ovens, a very particular operation known only to a few bakers. They are repeatedly taken out of the oven, and pressed flat with the hand, and then put in again.

10. *Woods and Plantations.*

Much planting has taken place on the poorer sands; Marsham of Stratton, the chief planter, and next Berney of Bracon, Coke, and Windham. From 1781 to 1801, Coke planted 718 acres, with upwards of two millions of trees and shrubs, of more than fifty kinds. Bevan, of Riddlesworth, 966,000 trees. Maquess Townshend feeds cattle, sheep, and deer, with the trimmings of plantations. Sheep are fond of the bark of the Scotch fir and ash.

11. *Improvements.*

A good deal of draining done of late years; very little irrigation; among the manures are reckoned marl, lime, gypsum, oyster shells, sea ouse, sea weeds, pond weeds, burnt earth, sticlebacks, oil cake, rape cake, ashes, soot, malt dust, ploughing in growing buck-wheat, yard dung, leaves, burning stubbles, river mud, and town manure. Marling, or claying as it is called, has been much used for an unknown length of time, and is found of great use on the sands; laid on at all seasons, but chiefly on the clover leys in autumn, and spread in spring, before ploughing for peas or oats; quantity, twenty to eighty loads an acre; duration, twenty to fifty years. Sea ouse, a calcareous mud, forty loads per acre. The sea mud is chiefly part of a stratum of rotten timber on the sea-shore, and which is washed out by the tides; it is perfectly black and rotten, and ten loads manures an acre. Burnt earth is the burnt ant-hills of moory meadows; ashes of cottagers who burn turf, &c. Leaves raked, stubbles burned, &c. by some. Some judicious and successful embankments made on the Ous, near Lynn, by the late Count Bentick, and continued by his son, the present Governor Bentick.

12. *Live Stock.*

Predominant cattle Scotch, bought in every year from the drovers, for feeding. Norfolk black-legged sheep gradually giving way to South Downs; folding on the decline. Poultry good, especially the turkey, owing to the dryness of the soil, and great range of pasture. Decoys, and pigeon houses, formerly numerous, but now on the decline. Rabbits, hares, pheasants, partridges, and rooks abundant.

13. *Political Economy.*

Charles II. observed, that Norfolk should be cut into roads for all the rest of England; few canals.

4. *Occupation.*

Farms generally smaller than in most other counties; few above 500 acres. Leases of fourteen and twenty-one years not uncommon; many of seven years. Farmers in general very ignorant, and much prejudiced against new practices.

5. *Implements.*

The prevailing plough a swing wooden-boarded implement, drawn by from three to six horses, and incapable of making good work under the guidance of the best ploughman.

6. *Arable Land.*

Very badly managed in general; on heavy lands two crops and a fallow, but the fallow kept unploughed for the sake of affording couch-grass leaves for the sheep. Davis of Bloxham, an extensive farmer and land-surveyor, "never saw any land upon which a naked fallow is necessary; not even on the stiffest soils;" has been in many counties, and employed on twenty-six commissions of enclosure at the same time! Wheat sown early, and either ploughed in or folded; often both. A scantlet of lentils cultivated. Turnips in most parts seldom bigger than

apples. A good deal of saintfoin on the Chiltern, and other calcareous soils, also on the stonebrash, which is chiefly lime.

7. Grass.

Some good meadows near Oxford, on the Thames and Isis; very rich grass land at Thame.

8. Woods and Plantations.

Of considerable extent. A great part of the forest of Whichwood belongs to the government. Great attention paid by Fane of Wormsley to pruning; many beech woods on the Chiltern hills; young wood at Blenheim neglected. The natural forests of Whichwood and Stoken Church chiefly of beech, but some oak, ash, birch, and aspen.

9. Improvements.

Fane, Prat, Davis, and others are of opinion, that the agriculture is much superior to what it was thirty years ago, chiefly from the introduction of a better breed of stock, the use of roots and herbage plants, and the enclosure of commons and common fields.

Scotch Farming. In 1809 an attempt was made to improve the estate of Great Tew, by letting it to Scotch farmers. As this originated in consequence of a pamphlet which the compiler of the present work published in 1808, it might be deemed a defect in this sketch if the circumstance were passed over without particular notice. It will, no doubt, long be recollected in the county as at least a ruinous project of wild adventurers; this being the very mildest term applied to failures in similar cases. At this distance of time, looking back on the matter, as far as the result affected ourselves, with our natural *sang froid*, we shall state our opinion as to the causes of failure. This resulted principally from too great anxiety, both in the landlord and tenants, to reap a large benefit; and secondly, from the general fall of prices, both of land and produce, which succeeded to the published report of the Bullion Committee in 1807. Anxiety to increase the rent-roll induced the landlord to let the whole of his estate of nearly 4000 acres, then under nearly a score of tenants, to two cultivators, instead of trying first the effect of one or two moderate-sized farms under the new mode. The same anxiety induced the tenants to offer too high rents, and to attempt a profit by subletting. Before the estate had been eight months let, it was sold on the new rental for nearly four times the sum at which it was offered for sale only a year before; but the title not proving satisfactory to the purchaser, the purchase was never completed. The landlord became involved in difficulties, owing to the expenses of new buildings, roads, drainages, the purchasing up of certain outgoing tenants, and other causes: he found, that though one person had been willing to buy the estate held on twenty-one years' leases, yet that it would sell much better if held by tenants at will; and was thence induced to buy up from the Scotch tenants the leases granted them two years before, and was still unsuccessful in endeavouring to sell the estate. At last the proprietor found himself with the greater part of his lands in hand; and one farm, it is proper to observe, was put under the management of an Irishman, who rendered himself notorious by some parts of his conduct, and finally left the country clandestinely; and whose actions have unfortunately often been confounded with those of the Scotch farmers, after all the latter had completely left that part of the country. When peace was concluded in 1814, land fell still lower; and finally this estate was sold for less than half what it had been sold for in 1809: but still (which may be considered as remarkable) for about double what was asked for it in 1807. It was in 1823 probably not worth a third part of what was given for it by the purchaser, from the change in the times; so that even had the original scheme and sale worked well, it is

probable that by that time both landlord and tenants would have been ruined; for more money might have been raised by mortgage on such an estate in 1810 than it would have sold for in 1820. The depreciation of the estate has been attributed to the breaking up of old turf; a most unfounded error, as there were not 1000 acres to break up, and of them only 250 were ploughed, and, as would have been proved had the convertible system been continued a few years, greatly to the benefit of the whole. We regret that the landlord, a most amiable and patriotic man, should have suffered in this business; but he entered into it aware that he was incurring an extraordinary chance of loss for an extraordinary chance of benefit, and of course he takes the result as every man ought to do. Besides he has still a very handsome fortune.

*As a trait of the spirit of the Board of Agriculture at this time, we may mention that Arthur Young examined the estate a few weeks after it was sold at so high a rate, and drew up a remarkable report (a MS. copy of which, from his office, is in our possession) in favour of Scotch farming, which was published in the first edition of Sir John Sinclair's *Husbandry of Scotland*. In that report a disingenuous attempt is made to attribute to the Board the merit of the introduction of Scotch farming into this and other counties; whereas it was and is perfectly well known, that the Farmer's Magazine, the Scotch farmer Gourlay, late of Wiltshire, and our pamphlet, were the true causes. By the time a second edition of the *Husbandry of Scotland* was called for, Scotch farming had become unpopular, and the Report mentioned, and all the compliments to the Board of Agriculture for having introduced it, were withdrawn. A general account of all the operations on Tew estate by Scotch farmers will be found in *Designs for Farms and Farm Buildings in the Scotch Style, adapted to England, &c.* 4to. 1812.*

10. Live Stock.

There is a good deal of dairying in the county; the permanent grass lands being chiefly occupied in this way. The practices are almost entirely the same as in Buckinghamshire. The butter is taken to London by waggons from all the principal towns. Much good dairying at Atterbury. A. Young asked John Wilson, of that neighbourhood, if he ever fed on straw? Answer, "No; straw be a good thing to lay on."

Sheep, the Berkshire, Gloucester, Wiltshire, Leicester, and other hardy breeds. Fane has tried crossing the Ryelands and South Downs with Merinos. Several other proprietors of farms have also tried Down Merinos and other crosses; and some the pure breed.

11. Political Economy.

Forty years ago roads "formidable to the bones of all who travelled on wheels;" now they are much changed for the better. Birmingham canal and the Thames of immense importance to Oxfordshire. A good deal of wool, formerly woven into blankets at Witney; now very little. About the beginning of the last century the manufacture of polished steel was introduced at Woodstock, and flourished for half a century; at present nearly extinct. Steel chains have been made here weighing only two ounces, and sold for 170*l.* Scissors from five shillings to three guineas. The steel is wholly made from old nails of horse-shoes. Leather breeches-making and glove-making have succeeded to the steel manufacture, and the latter thrives well: from 360 to 400 dozen of gloves are manufactured weekly.

12. Miscellaneous.

Dr. Sibthorpe, the late professor of botany at Oxford, left 200*l.* a year to endow a professor of agriculture and rural economy, to be established as soon as the *Fidra Graeca* is completed. This will not be for some years.

7790. BERKSHIRE. One of the most beautiful counties of England; occupies a surface of 474,000 acres, of which about 200,000 are enclosed, or in parks or plantations; 190,000 in common fields and downs; 40,000 in forests, wastes, and commons; and 8977 in roads. Its productions are almost equally corn and stock; it produces a good deal of butter and cheese, and the breed of swine is noted for its excellence. The celebrated Jethro Tull was a yeoman in this county. George III. and E. L. Loveden, Esq. were among its most noted farmers. On the whole it is a county much more indebted to nature than to art. (*Pearce's Berkshire*, 1794. *Mavor's Report*, 1808. *Marshal's Review*, 1813. *Smith's Geological Map*, 1821.)

1. Geographical State and Circumstances.

Climate diversified, but in every part the air pure and salubrious; in elevated situations pure, piercing, and braces by its sharpness; in the vales relieves the weak organs of respiration by its soft and balsamic qualities; no storms known in the county. About Reading vegetation nearly a fortnight earlier than in some parts of the county.

Soil calcareous in general, but in some places gravel, and in a few clay; vale of the White Horse entirely chalk.

Minerals. None excepting chalk, Sarsden stones, a sort of large siliceous pebble, in lumps scattered over the Wiltshire and Berkshire Downs, and frequently blasted and used for paving. In the vale of Kennet is a considerable stratum of peat, formed from prostrate trees and other vegetable bodies, and used for fuel, and also burned for the ashes as a manure. The ashes abound in sulphate of lime.

Water. Some artificial lakes for breeding fish. Loveden has one of thirty acres, and a "fish-house" or cottage, with an apartment in which are three stews with covers, which lock, so as to prevent even the cottager from stealing the fish. Many gentlemen have ponds, which are let to tenants, and produce a crop, if it may be so termed, every third or fourth year, of carp and tench. The occupier stocks with yearlings about two inches long, obtained chiefly from Yately, on the neighbouring confines of Hampshire. The breeders are about eight or nine pounds weight; but in the Berkshire ponds they are never suffered to breed, but are sold off to the inns at Henley and other places, when the ponds are drawn, which is generally once in four years, and weigh at that age about three or four pounds each. The value of land thus applied cannot average less than about twenty shillings per acre. The ponds are regularly laid empty, and the fish with which they are stocked, which are uniformly carp and tench, are taken out every third or fourth year. The pond is afterwards allowed to lie fallow for the remainder of the summer season, and is again stocked early in the ensuing year with yearling fry of the same species. The ponds in one parish are all subject to an abundance of coarse, hony, insipid fish, denominated Prussian or German carp. As this species is carefully destroyed, it is wonderful they

should increase with the rapidity and universality which they appear to do. Every acre of pond, properly stocked and well situated, must produce an annual increase of from eighty to one hundred pounds weight. If artificially fed, the increase would be greater; or less, if the pond is not so situated as to receive manure from the circumjacent lands. By retail, the fish here are generally sold at a shilling per pound; but under particular circumstances they may sometimes be had as low as tenpence.

2. State of Property.

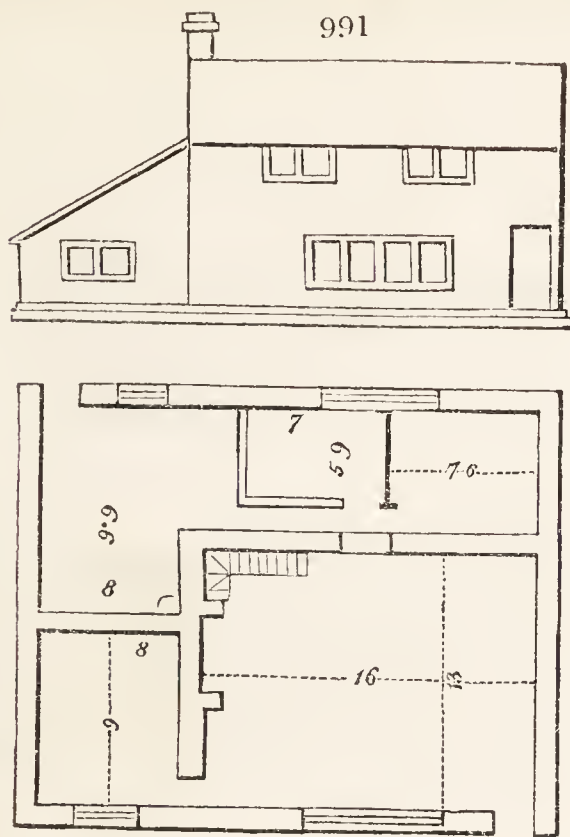
Largest estate 8000*l.* a year; a few of 5, 6, or 7000*l.*: Earl Craven and E. L. Loveden, Esq. the largest proprietors; several handsome seats with land not exceeding 100 acres, and many small freeholders and yeomanry. Some curious customs; at Enborne and Caddleworth manors, belonging to Earl Craven and R. W. Nelson, Esq., the widow of a copyholder, guilty of incontinency or marrying again, lost her freebench or life interest, unless she submitted to the ceremony of riding into the court on a black ram, and of repeating some well-known confessional lines. (See *Addison's Spectator*.) In the manor of Great Farringdon the customary tenant's daughter, on being convicted of incontinency, was to forfeit the sum of forty pence to the lord, or to appear in court, carrying a black sheep on her back, and making confession of her offence in these words: "Ecce porto pudorem posteritatis mei." Many other curious customs.

3. Buildings.

Windsor Castle and many fine seats; houses of the yeomanry genteel and elegant: farm-houses generally comfortable. Loveden's ample but ill arranged; cottages of the poor generally in a bad state, some present erections better. (*fig.* 991.) Farmeries on collegiate or corporate lands generally in bad repair, because the fines for renewal of the leases take all the spare money, &c.

Chelsey Farm, near Wallingford, in 1800, the property of Lord Kensington, and formerly reputed to be the largest and most compact farm in England. Rent 1000*l.* per annum. Before the dissolution of monasteries it belonged to the Abbot of Reading, who had a seat here. The great barn in which his

tithes were deposited is yet standing, and measures 101 yards in length and eighteen in breadth. The side walls are only



eight feet high, but the roof rises to a great height, and is supported by seventeen stone pillars, each four yards in circumference. This construction is obviously judicious; high side walls, unless tied together by cross beams, would have been in danger of being thrust outwards when the barn was filling with corn. This, as we have seen (7788.), is the case with the handsome high-walled barns of Coke.

4. Occupation.

One third of the county occupied by proprietors. Farms of all sizes under 1000 or 1200 acres, but few exceeding 500 acres or under 50l. a year. Character of the Berkshire farmer stands high. "A hospitable style of living, liberality of sentiment, and independence of principle, are characteristic of the Berkshire farmer; to which he unites persevering industry and integrity in his dealings, which render him worthy of the comforts he enjoys." (*Dr. Mavor.*)

5. Implements.

The Berkshire waggon, one of the lightest and best implements of the waggon kind. The sort of draught chain described and recommended by Gray (2755), is in use on one estate; "the object is to prevent the draught of the trace horse from pulling down the thiller." The county plough, a clumsy implement with wheels; a pressing plough (2714.) recently invented; it has three wheels with the tires wedge-shaped, and is intended "to press in the grips or channels made by the common ploughs, that no hollow places may remain for the seed to be buried too deep," &c. This sort of improvement is usual among amateur agriculturists, who have one implement invented to correct the faults of another, both of course bad. A number of other inventions, including a curious hand threshing machine, ingenious enough, but quite unnecessary, are figured and described. The Duke of Gloucester has, at Bagshot Park, one of the most complete threshing machines in the empire, which has been arranged under the direction and agreeably to the plan of his present farm manager, Mr. Burnes. Having received a plan of it too late for introduction here, we intend giving it in an appendix, for the benefit of agriculturists in countries where manual labour is dear, and where running water abounds.

6. Arable land.

Plough generally with four or five horses at a snail's pace. George III. had two farms, one of 800 acres, cultivated in the Norfolk manner, and another of 450 acres, managed in the Flemish manner; 450 of the former, and 150 of the latter, were arable. The whole delegated to the care of N. Kent, of Craig's Court, land-agent, and author of "*Hints to Gentlemen of Landed Property*," 1790. Rye cultivated on the Royal farms near Windsor, and on the Downs. Some hops, woad, flax, and other plants not usually cultivated; seventy acres of lavender at Park Place, on the side of a chalky hill, originally planted by General Conway, who distilled it himself at his coke manufactory. As the plants die they are replaced by others from a small nursery plantation. It begins to flower about the end of July, when nearly one hundred women and children are employed in cutting off the flower spikes, which they tie up in bundles, and send to the still-house in baskets, carried by two men. The lower part of the stalks are then cut off, and the heads are put into the still, and distilled. The chemical oil, being separated, is poured into copper jars for sale.

7. Grass.

About one fifth of the county under permanent grass, exclusive of the Downs and wastes. A tract of excellent meadow on the Thames, from the windings of the river, 105 miles in length, little irrigated, but a good deal flooded after heavy rains. Excellent meadows at Reading; those on the Kennet, over the stratum of peat, of rather a coarse quality. Manuring meadows not general, though they are for the most part mown once a year; upland pastures manured when mown. Herbage, plants, and artificial grasses, a good deal sown. Meadows chiefly fed by oxen after being once mown. The dairy farmers occupy

the poorer upland grassy districts, and the breeders of sheep the Downs.

8. Gardens and Orchards.

About forty acres of market garden and orchard at Reading, where onions are raised in great quantities; asparagus for the London and Bath markets, and cabbage seeds for the London seedsmen; good apples there and at other places; some cider made, and a good many cherries grown for market. Near Abingdon an orchard of twenty-one acres, containing 541 trees.

9. Woods and Plantations.

Extent of Windsor Forest, belonging to the crown, 5454 acres, including wood and water; private property, called Forest Lands, 29,000 acres; encroachments 600 acres. The forest is under the government and superintendance of a lord warden, who appoints his deputy lieutenant, the rangers or head keepers of the several walks, and the under keepers. Great part of the timber on the forest sold, as well as that retained, is truly venerable and picturesque in appearance, but rotten or mildewed to the heart in such a way as to be fit only for fuel. This rot, or mildew as it is called, seems to be the natural process of decay, and is particularly fatal to beech trees, which are by no means so long lived as the oak, ash, and others. Various young plantations on different estates, especially those of Loveden, Fische Palmer, Wheeble, &c. Osier beds on the moist parts of the Thames meadows. Extensive plantations have lately been made on the Duke of Gloucester's demesne at Bagshot, under the direction of his very intelligent managers, Christie, Barnes, and Toward. (*See Gard. Mag.* vol. vii.)

10. Improvements.

An account of the culture of George III.'s farms, by Kent, dated 1798, is given as of the greatest national consequence, &c. Oxen are used both in farm and road-work, and the ploughs are the Norfolk wheel plough and the Suffolk iron plough. At a later period the Rotherham plough, and with which two oxen, yoked in collars, will plough, on the light soil of the forest, an acre a day. Draining in the Essex manner a good deal practised; the drains filled with straw, rubbish from brick kilns, wood, cinders, or gravel.

Peat ashes is a manure almost peculiar to Berkshire, though they might be obtained by the same process wherever peat of similar quality abounds, and are so obtained in Holland, and the ashes extensively used there, and sometimes shipped to this country. In the year 1745 peat was first burnt in Newbury, by a Thomas Rudd, who at the same time spread the ashes on clovers, for which they have ever since been famous. An acre of peat land at that period sold for 30l.: it has since sold, according to its quality, for 500l. and 400l., and, in one instance, reached about 800l. per acre. Over the stratum of peat, which is about five or six feet deep, is a good meadow soil, and under the peat is gravel. The peat varies in colour, but the blackest is reckoned the best, and is used for firing, the ashes of which are most esteemed, and have the reddest colour. What is burnt for sale, is mixed with turf and other substances, which gives it a pale whitish hue. It is usually dug with a long-handled spade, from the middle of May to the end of June, and is conveyed from the spot in little wheelbarrows, to a short distance, where it is spread on the ground, and after lying about a week, the pieces are turned. This being three or four times repeated, a heap is made in the middle of the place where the peat is spread, and in the centre of this heap some very dry peat is put, which being lighted, the fire communicates slowly to the rest of the heap. When it is completely lighted, an additional quantity of peat is put upon the heap, and this operation is continued till the whole is consumed, which generally takes a month or six weeks, as quick burning is not approved of. Rain seldom penetrates deep enough to extinguish the fire. The heap is commonly of a circular form, and rather flat at top. At first it is very small; but at last it is sometimes two or three yards deep, and six or seven yards in diameter. The ashes being riddled, are conveyed away in uncovered carts, to a distance sometimes of twenty miles, and put into a house, or under a shed, to keep them from the wet, till they are wanted to be put on the ground.

The usual time of applying peat ashes is March and April. They are generally taken in carts, and sown on the ground before or after the seed is sown on the land. The quantity is usually from twelve to fifteen Winchester bushels per acre, according to the soil and crop. It is supposed that too large a quantity would be injurious. For barley, wheat, and peas, they are not in much estimation; but for all sorts of artificial grass, more especially, they are preferred to all other manures. In turnips they assist to prevent the ravages of the fly; and in grass seeds the farmers reckon on an acre, manured with ashes, producing nearly a ton of hay beyond what it would have yielded without them. The effect is supposed to be of no longer duration than two years. On meadow land, from fifteen to twenty bushels may advantageously be put; they much improve the grass.

11. Live Stock.

No particular breed of cattle; long horned most common. A dairying tract in the west of the vale of White Horse; much butter made, and some cheese of the single Gloucester kind. Calves a good deal suckled in some places. Buscot parish famous for cheses, in the shape of pine apples; they are of most excellent flavour, and sell higher than other cheses. The curds are well worked with the hands, then pressed into a wooden mould in the shape of a flower pot, and afterwards suspended from beams, rafters, or pegs, in an airy apartment, in a net, whose meshes indent their surface like a pine apple. Salt is then rubbed over them, or they are steeped in brine; weight, 5lbs. The milk is conveyed from the field to the dairies in what is called a tankard, drawn by a horse or ass. (*fig. 995.*)

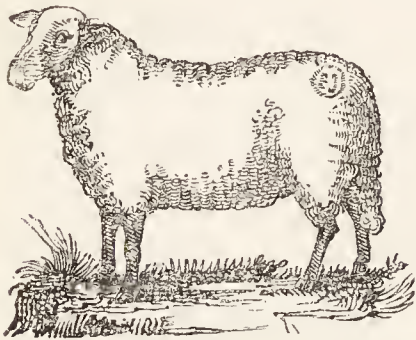
Sheep, a native breed known as the Berkshire polled, or notts (*fig. 992.*); strongly marked, but in much less repute than formerly; it is now difficult to be met with pure; they are considered as very hardy, and particularly adapted for the low strong lands, and for folding.

Horses of the common heavy black race. Pearce calculated in 1794, that 12,000 horses were kept in Berkshire for the purposes of agriculture, and that one third of the number might be saved by the use of improved implements: most of the horses are bought from the Northamptonshire breeders; many, after being kept a year or two at work, are sold for the London drays.

Hogs, the native breed one of the best in Britain; a cross

with the Chinese, now more common than the pure native breed. Wherever there is a dairy, hogs are kept, but they are not counted a profitable stock to be fed with what would fatten cattle or sheep. Carcass chiefly made into bacon; cured in the usual way, and dried in rooms heated with wood or coal. Loveden has a bacon house, heated by a stove and flues. In farm-houses, much is smoke-dried in the chimneys with wood fires, which is supposed to have the best flavour.

992



Poultry. Near Oakingham, many are crammed for the market: they are put up in a dark place, and crammed with a paste made of barley-meal, mutton suet, and some treacle, or coarse sugar, mixed with milk, and are found to be completely ripe in a fortnight. If kept longer, the fever that is induced by this continued state of repletion renders them red and unsaleable, and frequently kills them. In the eastern part of the county, many geese reared on the common.

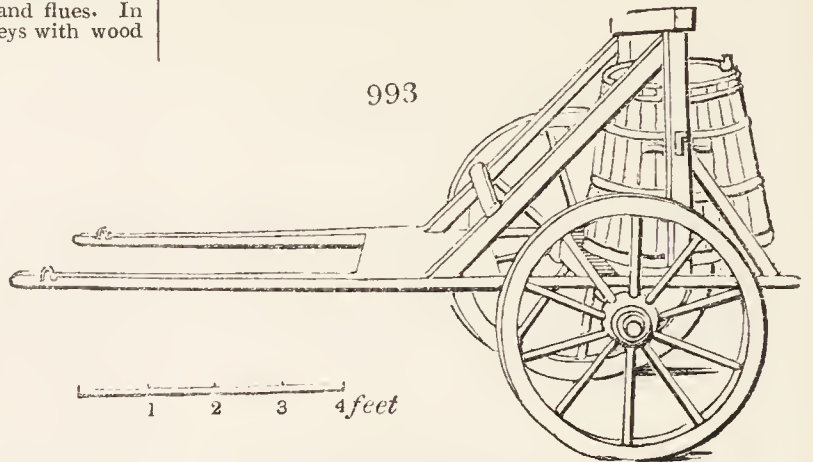
Pigeons in considerable numbers.

Bees, not very common. Sir William East, of Hullplace, a celebrated apiarist. In the forest district, bees are most common. One gentleman removes his hives to a heath at the flowering season.

Deer kept in several parks; 2500 fallow, and 300 red deer, in Windsor Great Park.

Rabbits kept in warrens, in one or two places; and one gentleman rears tame rabbits of a pure white, the skins of which sell high for trimmings.

993



12. Political Economy.

Roads for the most part good, especially since a part has been put under the care of M^r. Adam. Gravel, flint, or chalk, abounds in most places. Canals and navigable rivers so interspersed, that no part of the county is further than twelve miles from water carriage. Cloth for sacking and hammocks, manufactured at Abingdon and Maidenhead, also some sail-cloth, and rush, and twine matting. Cotton mills at Taplow. Paper, and formerly blankets and other woollens, at Newbury. A parchment manufacture at Oakingham. At Reading, a pin manufactory, and the weaving of galoon, satin, ribbands, and other light fabrics; a floor cloth manufactory; twine and rope making; sail making, sacking, &c.

The Berkshire Agricultural Society, established in 1794.

7791. GLOUCESTERSHIRE. A surface of nearly 800,000 acres, in three natural divisions; the Cotswold hills, the vale of the Severn, and the Forest Lands. Great part of the county is under meadows, pastures, and orchards; and cheese and cider are its known agricultural productions. It is also a manufacturing county, and its fine broad-cloths are celebrated, as well as its iron, tin-plates, and pins. There is no very eminent gentleman agriculturist, nor any agricultural society in the county, but Dr. Tennant farmed a small estate on the Chilterns. (Turner's Report, 1794. Rudge's Report, 1807. Marshal's Review, 1818. Smith's Geological Map, 1821.)

1. Geographical State and Circumstances.

Climate, cold and bleak on the Cotswold hills; mild in the vale, which lies open to the south winds; on the sandy soils of the forest district, the harvest is sometimes cut a fortnight earlier than in the vale.

Soil of the Cotswold is all calcareous loam or stonebrash; in the vale, a fine black loam, or fertile red loam, and in some places a strong clay and peat earth; the finest soil is generally sandy loam, sand, or peaty earth.

Minerals. None in the Cotswolds, but iron and coal in the Forest of Dean, both worked. Lead found in the limestone rocks of the lower part of the vale; not worked. Though iron ore be abundant in the Forest of Dean, only a small quantity is raised, it being found more profitable to bring the richer ore of Lancashire, which is burnt with the coke of the forest coal for cast-iron, and plates for tinning. Coal pits numerous, and worked at a shallow depth, for want of proper machinery to exhaust the water; three sorts delivered, kitchen coal, smith's coal, and lime coal. Claystone and freestone found in various parts of the forest; paving stones, grindstones, yellow and grey stone tiles raised in different parts of the Cotswolds; gypsum is raised for stuccoing, and sent to Bath from Hanbury; it is also used as alabaster for chimney pieces, &c.

Water. Produce of the Severn is roach, dace, bleak, flounders, eels, elvers, chub, carp, trout, and perch. The sea-fish taken within the limits of the county, in the Severn, are salmon, lampreys, lamperns, chad, soles, shrimps, cod, plaice, conger-eel, porpoise, and sturgeon. Salmon formerly caught in great abundance, but now comparatively scarce. Great mischief done by the use of small meshed nets, which take the samlets or fry.

Ponds for water made on the Cotswold hills, as already described (4467), in the vale in the common manner. The waters, which rise through beds of blue clay, are often strongly saline, as at Cheltenham, &c.

2. Property.

Largest estate 8000*l.* a year among the nobility, and 3000*l.* among the gentry; tenures chiefly freehold, some copyhold, and about one fortieth corporate or ecclesiastical. Estates under the see of Gloucester, leased out on lives; those of the corporation of the city the same; usual fine for renewal of a life, one year and a half of the improved annual value.

3. Buildings.

Many handsome seats; farm-houses and cottages on the Cotswolds built of freestone, and covered with stone tiles; often as many on an estate of 100*l.* a year as are required for a farm of 500*l.* a year, under the correction of modern improvement; barns, however, of a moderate size; wheat stacked on stone staddles. Cottages, as in most counties, neglected, and uncomfortable; some judicious remarks on the subject by Rudge.

4. Occupation.

Farms differ much in size; few exceed 1000*l.* or fall short of 50*l.* a year. Some grazing farms in the vale of 500 acres, but 200 and 300 more common. Leases of three years most common, next of seven years, not many of fourteen, and those of twenty-one on corporate property.

5. Implements.

A narrow-wheeled waggon in general use among farmers. Various ploughs; a short-beamed one-wheel plough in use

on the Cotswolds; in the vale a clumsy swing plough. Lumbert's draining-plough much in use with the improved draught apparatus, and in the old way. Various improved ploughs and other implements, as well as threshing and winnowing machines, introduced. A thistle drawer (*fig.* 221.) in use for extracting, the corn thistle (*Serratula arvensis*) from corn-fields; cradle-scythe used for cutting beans.

6. Enclosing.

The first enclosures during Queen Anne's reign; eleven during the reign of Geo. II.; and upwards of seventy during the reign of George III. Hedges of white thorn, on which the reporter observes medlars might be grafted, and raised in great plenty. Black thorn (*Prunus spinosa*) hedges, he says, never suffer from the blight; a most erroneous idea.

7. Arable Land.

300,000 acres; much ploughing on the Cotswolds lightens the staple of the weak soils: seven horses often used in the vale teams; ridges in the vale so high that a person six feet high may stand in the furrows, and not be able to see the crown of the second ridge from him; to reduce them a small ridge often begun between them. Fallowing practised on the clays, then wheat and beans, or oats. Rotation on the Cotswolds — 1 turnips, 2 barley, 3 and 4 clover mown the first year, 5 wheat, 6 oats, tares, or peas; if oats, frequently laid down with saintfoin. On crumbly soils wheat is sown and ploughed in during rather wet weather, otherwise the seedling plants are apt to be thrown out with the first frosts; the same thing attended to in Oxfordshire and various other counties; this is called seven-field husbandry. Beans either drilled or dibbled; a broad bean, the mazagan, used when the land is in good heart, and ticks when less so. The Burbage pea, an early grey variety, most in use. "Some lands have the peculiar quality of raising *siddow* peas, or such as boil freely;" on them the Charlton is grown, and sold for splitting; clay lands never have this property. Tares common, and among these a sort called dill, supposed by Marshal to be the *Ervum hirsutum L.*, but erroneously termed *Anethum* by Rudge. Turnips on the Cotswolds always broad-cast, and sometimes after wheat or tares, and then called stubble turnips; consumed by sheep in hurdle folds; sometimes given to horses, and found to induce them to eat barn chaff with a better appetite. Some flax raised; teasels a good deal cultivated formerly, now not 100 acres of them in the whole county.

8. Grass.

Very rich meadows on the Severn, overflowed during winter and spring, on which the farmers depends for a crop. When the salt water overflows, the meadows are termed marshes, and grazed by horses and cattle that require rest and spring physic. In general meadows are mown and pastured alternately, excepting near Gloucester, where abundance of manure is obtained. Herbage, plants, and rye grass sown on the Cotswolds, but little in the vale; saintfoin much cultivated on the stone-brash soils. Grass lands fed in general from May to the end of September, and then the cattle, unfinished, are taken in and completed with hay, oil-cake, and other artificial food, but seldom with roots. The *O'rchis mascula* so common in the meadows, that it has been gathered, Rudge informs us, and made into sago. (6184.)

9. Gardens and Orchards.

Most of the cottages, such as they are, have gardens, and almost every farm its orchard; but large ones, so as to admit of

making cider for sale, are found only on the sides of the hills and in the vale and forest district. The stocks are planted in the orchard when six or seven feet high, ten or twelve yards asunder on pasture, and sixteen or seventeen on arable lands. A year after planting they are grafted. Sometimes fruit trees are planted in the hedge rows; hedges are often composed of apple seedlings, raised from the kernels in the cider mast; and here and there the farmer often leaves a stem to rise above the general height of the hedge, and grafts it; frequently also wildlings are allowed here and there to rise into trees, and their fruit is used with that from grafted trees, in crushing for cider. Grafts are inserted in the cleft manner, at seven feet from the ground, two in each stock: if both succeed, one is removed the following spring, and the stock sloped to the remaining graft, to prevent the lodging of water, and clayed afresh, to facilitate the growth of bark over the wound. After grafting, "braids," that is, inverted wicker baskets, rising about two feet high, are fitted to the stock, which serve at once to guard the grafts, and direct their shoots to a proper form. The stock is next protected from cattle or the plough harness, by four posts placed round it, with six tier of rails; by three posts and six tier of rails; by two broad posts and rails; by a bundle of thorn branches; by planting a thorn or briar along with the stock; or by twisting a shoot of the creeping rose (*Rosa arvensis*) round the stock. The mode of planting a creeping rose with the stock, and twisting it round the stem, is said to be found the cheapest and best; but it must evidently impoverish the soil. Pruning is not attended to on young grafted trees, or any others, as it ought to be, nor the removal of moss and mistletoe. Grafting the branches of old trees often practised with great success; a young stock grafted will probably not produce a bushel of apples in twenty years, but a branch grafted bears the second year. Dr. Cheston, of Gloucester, practises root grafting, but which is quite unsuitable for field orchards. Grafted trees bear little till twenty years of age; their produce increases till fifty years, and is then ten or fifteen bushels; an apple will bear 100 or more years from this period, and often much longer. A pear tree at Minsterworth 500 years old at least.

Cider-making. Best orchardists shake off the fruit, and never beat the tree, which destroys the blossom-buds; limb by limb is shaken by a person in the tree, and those which adhere allowed to remain some time longer to ripen: the horse-mill used by large, and the hand-mill by small farmers; the cylinders of the hand-mill of wood, and fluted; sometimes there are two pair of cylinders, one finer fluted under the first pair,

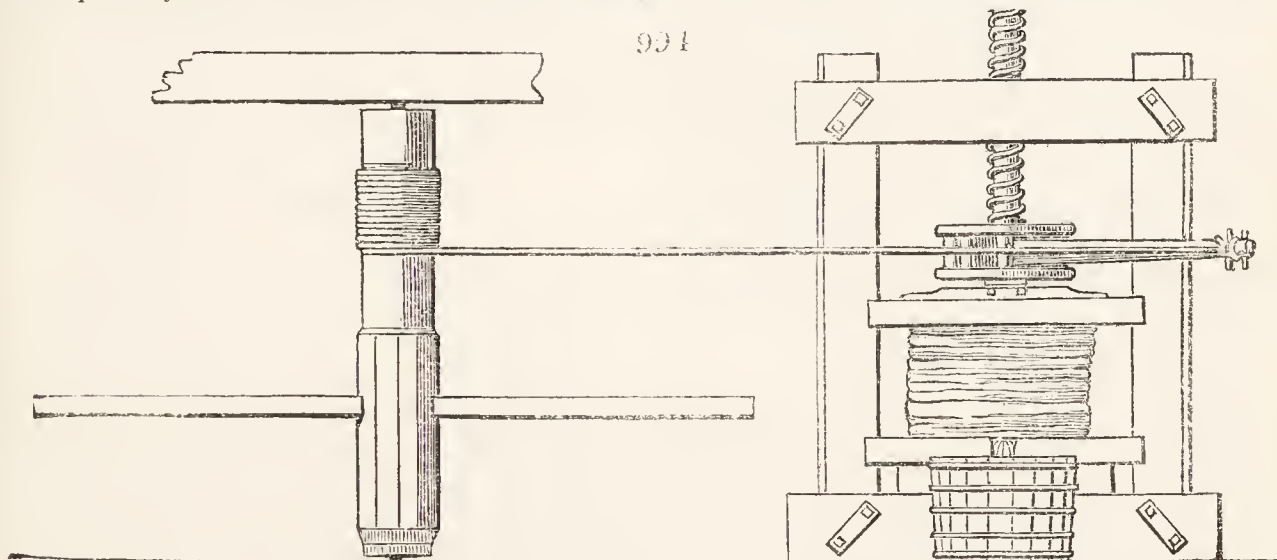
and in other cases the cylinders are set wide the first time the apples are passed through, and closer the second; the other processes as usual. Of the various apples grown, the white-styre of the Forest district makes the strongest and richest cider; it is often valued equally with foreign wine, and sold at extravagant prices. Ciders from the Hagloe crab, golden pippin, and Longney russet, are next in esteem. The white-must, woodcock, and half a dozen others, are fine old fruits, but now going off.

Perry from the squash pear is esteemed the best; and next from the Huffcap and sack.

Table fruits, where farmers live near canals, pay much better than those of the cider kind; especially those of the keeping varieties, such as the golden and Moreland pippin, Longney russet, &c.

10. Woods and Plantations.

Most extensive on the Cotswolds; the sorts there beech and ash; timber sold to dealers, who convert it on the spot to scantling for gun-stocks, saddle-trees, bedsteads, chairs, and other cabinet work, and staves for sugar hogsheads. Some fine old specimens of chestnut, elm, oak, and ash in the vale. Tortworth chestnut, 500 years old, in the time of King John. In the Forest of Dean a considerable quantity of good timber belonging to government, and nearly 3000 acres lately planted with acorns. The method of planting is, first, to mark out the ground; then taking off about a foot square of turf, to set two or three acorns with a setting-pin; afterwards to invert the turf upon them, and, by way of raising a fence against hares and rabbits, to plant two or three strong white thorn sets round. They are seldom thinned till they have attained the size of hop poles, and then are left at twelve feet distance from each other, with the view of again thinning them, by taking out every other one, when they are thirty years old, and have attained the size of five or six inches diameter. By growing thick, no side-shoots are thrown out, which supersedes the necessity of pruning; the young trees which are drawn at the first thinning are transplanted, and, as it is thought, grow equally well with those that have not been removed, and produce timber as full at the heart, compact, strong, and durable, as "that which is raised immediately from the acorn." The "whitten," or small-leaved lime (*Tilia cordata L.*), is found in several coppices on the Welsh side of the Severn; and, what is singular, ropes for halters, plough traces, cider presses (fig. 994.), draw wells, and fishery boats, &c. are made from it as



in Russia. These ropes are found to contract and expand less from moisture or drought than hempen ropes. The bark is stripped off about Midsummer, dried like hay in the sun, and manufactured on the spot or elsewhere. Many walnut trees in the parish of Arlingham; the fruit shipped to distant places, and the timber sent to Birmingham for gun-stocks.

Artificial plantations, to a great extent, made round gentlemen's seats on the Cotswold hills. The osier in beds on the Severn.

11. Improvements.

On the lands adjoining the Severn inundations were frequent; but a commission of sewers have erected banks and flood-gates, which protect upwards of 12,000 acres. At other places private banks or floodgates on the rivers or banked ditches are placed, and operate by the alternate influence of the tides and accumulated inland waters.

Draining much practised; both in the turf, stone, wood, straw, and with Lambert's plough; the plough drawn by twelve horses, or worked by a long lever and axle (2645.), by which one horse gains the power of thirty. Before the mole draining plough is used, it is a good practice to turn off the sward with the common plough; then to make the incision for the drain in the centre of this; the sward being afterwards turned back to its place, completely covers the aperture, and protects it from the effects of a subsequent dry season. The long-continued drought of the summer of 1806 opened many drains which were cut by Lambert's plough, so much that the bottom was clearly seen; while many that have been done by hand have formed still wider chasms, and will probably not answer the purpose intended at all. In both instances there is reason to think, that this would not have happened if the operation had been performed in autumn, and the surface turf first turned back, as recommended.

The accumulated water of underground drains raised from low meadows in one parish by a wheel driven by the water of surface ditches.

Paring and burning practised on the Cotswolds; weeding corn general.

Irrigation chiefly pursued in the valleys of the Cotswolds, adjoining rivulets, and especially the Coln and Churn. Carried to greatest perfection in the parish of South Cerney; first began here under the Rev. W. Wright, who wrote several tracts on the subject. When the first great rains in November bring the

waters down in a muddy state, it is let into the meadows. In December and January the land is kept sheltered by the waters from the severity of frosty nights; but every ten days, or thereabouts, the water is let entirely off, to give air and prevent the roots from rotting. In February great care is required. If the water now remains long on the meadows, a white scum will generate, which is found to be very injurious to the grass. On the other hand, if it be taken off, and the land exposed to a severe frosty night, without being previously dried for a whole day, much of the tender grass will be cut off. Towards the middle of this month less water is used than before, keeping the land rather wet than watered. At the beginning of March there is generally in such meadows plenty of pasturage for all kinds of stock; the water, however, should be taken off nearly a week before cattle are turned on, and a little hay at night during the first week is very proper. It is the custom with some to spring-feed with ewes and lambs folded, with a little hay. The meadows, however, must be entirely clear of stock by the latter end of April. If May be at all intruded on, the hay crop will be much injured, and the grass become soft and woolly, like lattermath. After spring-feeding the water is let in again for a few days. It is remarked, that autumnal, winter, and spring watering will not occasion rot in sheep; but if the water be used for a few days in any of the summer months, the pasturage becomes unsafe for such stock. This is conformable to the general idea of rot; viz. that it is occasioned by summer moisture, and is seldom known to any considerable extent without a long continuance of warmth and rain. A wet summer, therefore, is always productive of this disease in the vale. The general advantages of watering are, that the land and herbage are continually improving, without manure; and the crop is not only full and certain, but also early.

Warping might be practised to a considerable extent on the banks of the Severn, if the commissioners were to direct their attention to the subject.

12. Live Stock.

The dairy the principal object with most of the vale farmers. Good milkers preferred, without much regard to perfection of shape. Gloucestershire breed resembles the Glamorganshire excepting in colour, which is red or brown, bones fine, horns of middling length, white with a black tip at the ends, udder thin in flesh and large. In the higher vale the improved long

horned cows of Bakewell and Fowler in most repute. Devons, Herefords, and various others in use. The best land does not always produce the most marketable cheese; oftentimes the reverse; if it has either been much manured with dung, or sheep feeding, the quantity of milk will be increased, but the quality materially altered. This is probably owing to the introduction of plants, which did not grow there before, or to the destruction of some that did. The cause does not originate with the cow, but the herbage on which she feeds. The same cow, on two pastures, separated only by a hedge, will give milk of different qualities: from one shall be made fine, rich, and close cheese; while from the other shall be made rank, "heaving," hollow, unpleasant to the palate, and unfit for the market. In the parish of Haresfield, two grounds adjoining each other were alternately used for the pasture of cows: while they were on one, excellent cheese was made; but on the other, it was difficult to make any tolerably good. The latter had been lately well dressed with manure, which produced plants unfavourable to the dairy; and the dairy woman herself remarked, that if the farmer continued to enrich the herbage with dung, she must give up making cheese. It is proper, therefore, that milking-cows should not be removed from one pasture to another indiscriminately, but that certain grounds, in proportion to the stock, should be assigned to their use; and this is the practice on many farms where cow pastures have for time immemorial been appropriated exclusively to the use of the dairy. The dung of the cow, indeed, being of a cooling nature, is the best manure for cow-pastures. Other animals, such as colts and sheep, may occasionally be let in to eat the refuse grass, but not more than one sheep should be allowed to an acre. Among the plants which are useless, or unfavourable to the making of good cheese, are white clover (*Trifolium repens*), the different kinds of crow-foot

7792. WORCESTERSHIRE. A surface of 431,360 acres, according to the official estimates laid before parliament, though some of the calculations which have been published make it amount to 599,040 acres, distinguished by the two extensive vales of Worcester and Evesham. In the fertility of its soil, and the amenity of its situation, surface, and natural embellishments, very few districts of similar extent are equal to it—scarcely one excels it. And its agricultural products are not only more abundant, but more various, than those of other counties; not corn, cattle, and dairy produce only, but fruits, liquors, and hops, rank among its productions. (*Pomeroy's Worcestershire*, 1794. *Pitt's Report*, 1807. *Marshal's Review*, 1818. *Edin. Gaz.* 1827.)

1. Geographical State and Circumstances.

Climate of the middle, south, and west of the county, remarkably mild, soft, and salubrious; the vales of the Severn, Avon, and Teme, with the contiguous uplands, rising to 150 feet above their level, ripen their products from a fortnight to a month earlier than what takes place in elevated counties, even with a similar soil and surface; sixty yards perpendicular = one degree more to the north; conformably to this idea, early at Worcester, and late at Birmingham. Apparently much less rains falls here, than in counties more elevated and more inland.

Soil. Ten thousand acres of deep rich sediment deposited by the Severn, and a good deal on the Avon, Teme, and Stour; half the rest of the county, rich clay and loam: some light sandy soils about Kidderminster, and springy gravel about Bromsgrove.

Minerals. Brick-clay, gravel, sand, marl, freestone, coal, at Mable; quartz, a siliceous stone, forms the basis of the Malvern hills. Extensive lime quarries and coal mines at Dudley; excellent common salt at Droitwich.

Water. Rivers, but no lake, pool, or pond formed by nature. Malvern well, a good chalybeate; it is limpid, without smell or taste.

Fish in the Severn, salmon, shad, lamprey, and lampern; the lamprey grows to twenty-six inches long, and is often three or four pounds in weight; it leaves the sea in the spring, and is esteemed a great delicacy, but unwholesome when eaten too freely. The lampern goes to the sea at certain seasons; is ten or twelve inches long, about the size of a man's finger, and common in Worcester, potted or preserved; vast quantities sold for baits to the eel fishery.

2. Property.

Variouly divided among all classes; many resident families of considerable opulence and fortune.

3. Buildings.

Some magnificent residences; farm-houses erected at different times, and no way remarkable, unless for being badly situated and arranged; great want of sheds for cattle. Cottages have nothing to recommend them; often built of timber and plaster, and covered with thatch. Some good stone bridges over the Severn, and an iron one of one arch, 150 feet span and fifty feet rise, at Stourport.

4. Occupation.

Farms small from 40*l.* to 400*l.* a year, but some larger; seldom held on lease; but when a tenant takes a farm on strong lands, where the course is fallow and three crops, he holds it by custom for four years. Knight, of Lea Castle, farms 350 acres in a masterly style; large farmers have a turn for improvement; small ones have seldom an opportunity; many inventions proposed and introduced, but the sensible farmer unfortunately finds few of them that will answer.

Picturesque farming by Knight. About 200 acres around Lea Castle, formerly in irregular uncouth divisions, with wide slovenly hedges, are now laid, or laying together, the roads better disposed both for convenience and appearance, and the hedges stocked up; but the trees, which are in abundance, carefully preserved, to give a park-like appearance; this is divided into lots by temporary hurdles.

Military farming. The same gentleman, when the volunteer cavalry were raised, sold his heavy farm horses, and bought light ones, chiefly Clevelands, on which he mounted ten of his own servants for military service. The horses doing all the farm work, and occasionally serving for saddle horses, or to draw his carriage.

5. Implements.

Plough two-wheeled, and drawn by three horses in a line, walking in the furrow; in the vale of Evesham, a heavy swing plough; these ploughs are seen nowhere else; they are all wood, excepting the share and coulter; very long in the tail, throat, and sideboard; a load for a team; the four-wheeled trolley is a low wagon, used for harvest work. Knight uses improved implements, and ploughs with two horses abreast. Various drills for sowing wheat, and stirring the soil between

(*Ranunculus*), and garlic (*Allium*). White clover is brought forward by manure and sheep stock, and is a proof of good land, at least of land in a state of high cultivation; hence it has a tendency to raise the quality of the milk, and make the cheese heave.

Cheese-making. Best cheese not attempted while the cows are on hay; generally commences about May, when the cows are turned into the pastures. Cows milked twice a day, at four in the morning, and at the same hour in the afternoon; the cheese-factor discovers the "hoved" cheese by treading on them.

Sheep. Principal breed the Cotswolds; now very much mixed by crosses with the Leicester and South Downs. The liver rot common in the vale, and therefore few bred there. Wiltshires are bought in and fed off.

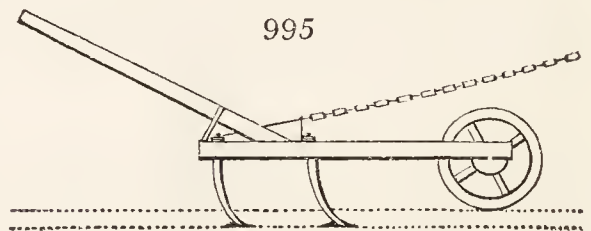
Horses, no particular breed.

Pigeons, formerly numerous, now on the decrease.

13. Political Economy.

On the hilly districts, where stone abounds, the roads greatly improved of late; those under M'Adam excellent; but the vale roads in many places very bad. Manufacture of woollen broad-cloths, chiefly superfine from Spanish wool, extensively carried on in the district called the Bottoms. Carpet weaving and thin stuffs at Cirencester; stocking frame knitting at Tewkesbury; wire, cards, rugs, blankets, iron and brass wire, tin plate, pins, writing paper, felt hats, manufactured at different places. Spinning of flax the winter work of women in the vale of Evesham. Extensive iron works in the forest; the best iron in the kingdom made at Huxley; nails made at Littledean. Articles of agricultural commerce, cheese, bacon, cider, perry, grain, and salmon, to the extent of 4000*l.* per annum; in manufacturing commerce, broad-cloths and pins are of the greatest importance.

the rows (*fig.* 995.), manufactured at Evesham, and used in the neighbourhood.



6. Arable Land.

Fallows ploughed four times, which is rather rare in England; rotations generally a fallow and two corn crops, with an intervening leguminous herbage, or turnip crop. Drilling in use for wheat, in the vale of Evesham and other places; beans commonly dibbled. Turnips cultivated broad-cast; and Carpenter, author of *A Treatise on Practical and Experimental Agriculture*, has discovered since he published his book, that the fly is to be prevented or destroyed by steeping the seed in sulphur before sown, and harrowing as soon as the fly is discovered; "then sow eight bushels per acre of dry lime, or fine ashes, when the dew is on the leaves, so as it may adhere to them." Carrots sown by Knight and others in the neighbourhood, where a good deal of seed is raised for the London seedsmen.

Hops grown to great perfection, and fruit trees generally planted among them, at the rate of forty-eight to an acre; 1000 stools of hops are considered an acre, whatever ground they may stand on, and labour is paid for accordingly. Golding-vine, mathon-white, red, nonpareil, and Kentish grape, local names for varieties distinguished by very slender shades. Land stirred between the plants with the plough; only two poles to a stool; picking chiefly by Welsh women. When tithe of hops is taken in kind, the parson may either take every tenth basket when green, or every tenth sack when dried; in the latter case, allowing 25*s.* per cwt. for drying, sacking, and duty. The culture of hops having been carried too far, the trade here, as elsewhere, is on the decline; corn, on the average of years, is found to pay better.

Asparagus, cucumbers, and onions, grown in the fields of Evesham, and sent to Birmingham market, though thirty miles distant; also, poppy-heads for the London druggists. Clover for seed in various parts of the county.

7. Grass.

The banks of the rivers chiefly under meadow of the very richest kind; employed chiefly in fattening cattle and sheep; clovers and rye grass cultivated.

8. Gardens and Orchards.

Market gardens near most of the principal towns; produce, besides local consumption, is sent to Bath, Bristol, and Birmingham. Orchards, long and successfully cultivated in the middle, south, and western parts of the county; round towns, villages, and farm-houses; and all the hedge-rows of a farm often planted with fruit trees, and very productive. In a plentiful year, or what is called a "hit of fruit," it will not pay for carriage to market from remote places; no casks can be got for all the juice. In 1784, cisterns were formed in the ground to receive the liquor, but they ran out; in Pershore, it is said currents of perry ran into the common sewers. Large quantities of apples rot, or are devoured by hogs; cider in such a year sold for 21*s.* a hoghead, in Worcester market; two or three tons of cherries often sold in Worcester market in the morning before five o'clock; six tons have been sold there in one morning; 2000*l.* has been paid for the tonnage of fruit on the Trent and Severn canal in one year: canal forty-six miles long, tonnage 1½*d.* per ton per mile; 7000 tons must

therefore have passed. The stocks are not grafted here till three years after planting out, and saddle grafting of a peculiar kind (*fig. 996.*) is preferred to the cleft manner used in Gloucestershire. Sometimes the boughs of the stock are each grafted in the whip manner. When cleft-grafting is performed, the cleft is made with a saw, and afterwards smoothed with a knife; little care paid to the trees afterwards; they bear at five years, are at perfection at thirty, and continue in full bearing for at least thirty years more. Sheep should be excluded from the orchards, and coarse grass or straw burned in them on the first appearance of a blight; this fumigation destroys myriads of insects. Fruit is gathered as it falls from the tree; no force used till the leaves are mostly fallen, and then only shaking or striking with a light pole. Cider made as in Gloucestershire, but with no great attention to the mixture of fruit, or its previous sweet and clean state. Pomeroy proposes to separate the core and kernels from the pulp, by forcing a cutting cylinder through each apple, and then grinding the core and pulp apart, as much of the flavour of cider depends on bruising the seeds.



9. *Woods and Plantations.*
Abundance of oak and elm. Croome, Hagley, &c. well-wooded. Forest of Wire, near Bewdley, supplies oak poles, rails, hurdles, laths, hoops, &c.

10. *Improvements.*
Earl of Coventry drains his park by open cuts wide, and their sides turfed to the bottom; all the attention they require is preventing the establishment of large weeds or coarse tufts of grass, which would interrupt the water; some embankments on the Severn, and some meadows irrigated, but mostly by floods.

11. *Live Stock.*
No particular breeds; land too good for breeding; feeding chiefly attended to, and some dairying; some soiling, and a good deal of oil-cake used for finishing autumn-fed oxen. Mules used in agriculture in some parts of the county, especially near Bewdly; rise to fifteen hands or more; Skey's carriage mules bred from grey or white mares and a white spotted foreign ass. The great age to which they attain is one of their chief advantages; at perfection at thirty, and work till seventy or upwards. Asses employed by Carpenter, of Bromsgrove, farmer and author.

12. *Political Economy.*
Principal roads good; cross-roads very bad. A subterranean

canal near Dudley A road club, established in the vale of Evesham in 1792, the members of which bind themselves to become road surveyors, gratis, in their turns, and strictly to enforce all laws, and to take all the means in their power for procuring and keeping good roads. Several canals, fairs, and markets. Manufactures of gloves in Worcester, and also of porcelain and cabinet furniture: of woollen cloth and glass at Stourbridge; of glass and nails at Dudley; leather-making from sheep-skins at the same place; nails, needles, linen, wool-combing and spinning at Bromsgrove and Redditch; tanning in most places; carpets at Kidderminster; various iron works on the Stour; stocking frames at Tewkesbury and Bredon.

Droitwich salt works on record from 816. The strata over the salt are, mould five feet, marl thirty-five feet, talc, a gypsum or alabaster, forty feet, then a reservoir of brine twenty-two inches, then talc seventy-five feet, then a rock of salt, into which the workmen bored five feet. The brine is inexhaustible; on boring through the talc, it immediately rises and fills the pit. Salt made here and sold in one year, from April 5. 1771, to April 5. 1772, 604,579 bushels; of which exported abroad, 110,120 bushels. Duty paid into the salt-office, London, 61,457*l.*, which was then nearly one third of the whole revenue from salt in England. The process of making salt at Droitwich is as follows:—A little common water is first put into the pan, to keep the brine from burning to the bottom; the pan is then filled with brine, and a small piece of resin thrown in to make it granulate fine; when the brine is boiling, the salt first incrusts at the top, and then subsides to the bottom; when subsided, the persons employed ladle it out with an iron skimmer, and put it into wicker barrows, each containing about half a bushel, in the shape of a sugar loaf, and let them stand at the side of the pan for some minutes to drain; they then drop the salt out of the barrow, and place it in the stove to harden. In 1775, Baker, a druggist, from London, spent 12,000*l.* in a project for conveying the Droitwich brine in pipes to the Severn, without success. Dr. Nash, from experiment, believes Droitwich salt to be neither manure in itself, nor capable of exciting any vegetative principle on the earth, as animal or vegetable salts or lime may do; it produces bad effects on ploughed lands, by increasing their dryness in hot weather, and by making them greasy, and what the farmers call raw, in damp weather. He has found it serviceable to scatter foul salt upon large heaps of manure, to kill weeds and destroy their seeds, but not to enrich; care must be taken that it be not laid near the roots of the trees, as it will certainly destroy them. If laid at the bottom of pools, it enables them to hold water; it is wholesome to granivorous and graminivorous animals, but prejudicial to carnivorous ones.

13. *Means of Improvement.*
The establishment of village and parish libraries recommended; and a paper on the subject copied, which appeared in the Worcester newspaper. From the books recommended, as well as other evidence, the writer of this paper is Sir Richard Phillips. The plan is excellent, and would probably, in the course of a generation, effect a complete change in the lower classes of society. Le Couteur's treatise on apple trees and cider, as applicable to the Isle of Jersey, appended to the survey.

7793. **MONMOUTHSHIRE.** A surface of 316,800 acres varied by hills, some of which are of considerable height; more distinguished by its woods and its mineral products than its agriculture. A part of the coal basin of South Wales a fund of wealth of immense consequence to Britain, extends into Monmouthshire, and, with the iron works, forms an important source of industry and wealth. (*Hassall's Report, 1811.*)

1. *Geographical State and Circumstances.*

Climate. Mild in the vales and cold on the confines of Breconshire, where the snows sometimes remain on the ground till a late period in spring; atmosphere humid, as in most western counties; highly favourable to the growth of grass.

Soil. Clay, loam, and grey soil on rock or marble, and beds of limestone. Caldicot and Wentlog levels on the Severn; under the court of sewers is a rich silty loam. Soil of the hills a reddish loam. No poor soil in the county.

Minerals. Coal, iron, and lime. Upwards of twenty iron works in the coal district; coal not brought into general use till 1792, when the canals and rail-roads were completed. Principal proprietors of the mineral district, Sir Chas. Morgan, C. Leigh, Esq., B. Hall, Esq., and the Earl of Abergavenny. A particular description of the mineral basin of South Wales given by Martin (*Phil. Trans.* 1806).

2. *Property.*

Duke of Beaufort and Sir Chas. Morgan the chief proprietors; next class, 1000*l.* to 5000*l.* a year; a third class, 500*l.* to 1000*l.* a year. Many proprietors occupy a part of their estates, and cultivate them well; some very small proprietors of orchards and grass lands.

3. *Buildings.*

Some fine old seats; farm-houses of the oldest date, timber thatched; new ones covered with tile stone; seldom any farm-yards; but cattle-houses and barns scattered about at random; cottages on the most frugal plan, generally with a garden.

4. *Occupation.*

Size of farms, 60 to 500 acres; 140 acres about the average; leases not very general.

5. *Implements.*

The proprietors of iron works have introduced many improved forms from the north; very neat iron gates and posts. (*fig. 997.*)

6. *Arable Land.*

Less than the pasture; tillage chiefly by oxen. "Many farmers are so circumstanced, as to be ever on the watch, lest the avarice of their landlords should interfere with their industry, by taking advantage of any improvement they make in the soil, and unexpectedly raise the rent. That such unfair dealing is become too frequent, is much to be lamented, and can only be guarded against by leases."

7. *Grass Land.*

"Some farmers insist on it that rushes shelter and protect grass, and will not allow them to be removed by draining or otherwise."

8. *Gardens and Orchards.*

The latter very general on a small scale; apples for eating much in demand at the iron mills; best orchards and hop-grounds in the hundred of Ragland.

9. *Woods and Plantations.*

County long famous for the size of its oaks; stock now much diminished.

10. *Live Stock.*

Mixed cattle; some dairying, but feeding more general; Hereford horses a good deal bred; asses and mules in use about the iron works: the mules found better than horses for carrying charcoal from the woods to the iron works.

11. *Political Economy.*

Valentine Morris, Esq., of Piercefield, being examined as to the roads of the county, before Parliament, was asked,—

Q. What sort of roads have you in Monmouthshire?

A. None.

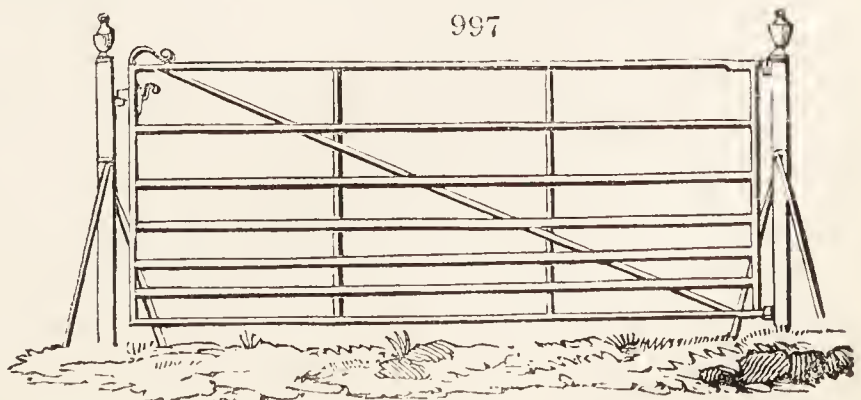
Q. How do you travel then?

A. In ditches.

This was thirty years ago (1800); they are now (1830) improved, but still bad; various railways and canals.

12. *Means of Improvement.*

Leases; embanking the river meadows; drainage; knowledge.



7794. **HEREFORDSHIRE.** A surface of 600,000 acres, studded with hills, hillocks, and minor swells of various heights and dimensions; almost every where of a rich soil, devoted exclusively to agriculture, and highly productive in corn, cattle, fruit, cider, hops, and timber. The most distinguished cultivator in the county is T. A. Knight, Esq., known in agriculture by his Treatise on the Apple and Pear, many valuable papers in the Transactions of the Royal Society, and communications to the Board of Agriculture; and in gardening by numerous essays and improvements, and his honourable office of President of the Horticultural Society. (*Clark's Herefordshire*, 1794. *Duncombe's Report*, 1808. *Marshal's Review*, 1818.)

1. Geographical State and Circumstances.

Climate, remarkably healthy; west winds the coldest; warmest and earliest part about Ross.

Soil. A marly clay of great fertility extends over most of the county. The heaviest crops of wheat produced on a clayey tract between Hereford and Ledbury; the lightest lands in the south-east about Wormelow, and known as the "Rye lands," from the prevailing produce there in former times.

Minerals. Iron ore in the sandy district, but none manufactured at present. Red and yellow ochres, pipe-clay, and fullers' earth, but only the latter worked for.

Water abounds; salmon caught in the Wye, but, owing to the weirs and illegal practices, not so abundantly as formerly.

2. Property.

Guy's Hospital, Duke of Norfolk, Earl of Oxford, Earl of Essex, Sir G. Cornwall, &c. the largest proprietors. Their estates divided into farms of from 200 to 400 acres. A number of estates from 400*l.* to 1000*l.* per annum constantly resided on by their owners, and cultivated and managed in good style, with a view to the introduction of the best agricultural practices. The tenures of gavelkind and borough-english exist in a few places, but are generally nullified by will.

3. Buildings.

Some fine seats of proprietors, as Hom Lacy, Hampton Court, Downton Castle, &c. Old farm-houses of wood, ill designed, and placed: some good new ones on the Guy's Hospital and other estates. Cottages very humble, and of an inferior construction. Strawberries lately cultivated by some cottagers, for the Hereford market, with success and profit.

4. Occupation.

Small farms on the decline; few opportunities now by which an industrious couple can devote 50*l.* or 100*l.*, acquired by personal labour, to stock a few acres, and bring up their family, and pass their latter years in comparative independence. Hence matrimony on the decline, and licentiousness on the increase. Hence Duncombe humanely recommends proprietors to forego the temporary advantages of throwing the whole of their estates into large farms, and advises some of all sizes, from 5 to 500 acres, as ultimately best for the country. "The old-fashioned farmer of Herefordshire receives any new experiment in agriculture with great hesitation, if not reluctance. When its utility is confirmed by repeated trials, he slowly and gradually falls into the practice; but he wisely leaves the experiment and the risk to those who recommend or suggest it; and happily the county is at this moment well provided with agriculturists, who possess the means and the spirit to undertake the patriotic task." Leases of twenty-one years most commonly in three periods of seven years, determinable at the end of each period by either landlord or tenant.

5. Implements.

Plough called the light lammas, without a wheel, and drawn by three or four oxen generally in a line, abreast; but often the yoke is the usual mode of harnessing. Various improved implements by the amateurs, but none in general use.

6. Arable Land.

Wheat principal grain cultivated, and generally sown on a fallow. Change of seed procured from the chalk hills of Oxfordshire; steeped in brine and lime, to guard against vermin and smut. Knight, late of Eaton, now of Downton Castle, steeps in water and then envelopes in lime, and his wheat was as free from smut and other diseases as that of his neighbours from changed seed. Hops a good deal cultivated, and chiefly disposed of to Bristol dealers.

7. Grass.

Fertile meadows on the Wye, Frome, and Lug; mown and fed. Not a dairy county for home consumption, seldom for exterior markets, or Smithfield. Butter supplied from Wales, and cheese from Shropshire and Gloucestershire. "The general soil of Herefordshire appears to be unfavourable to the making of cheese. T. A. Knight, with that accuracy and skill which he is known to possess on all subjects connected with agriculture and natural history, has proved by experiment, that equal quantities of milk in Herefordshire and Cheshire will produce unequal quantities of curd, highly to the advantage of Cheshire: and farther, that better cheese has been produced in that county, from milk, half of which has been previously skimmed, than is produced in this from milk altogether unskimmed. The want, therefore, of complete success in this valuable branch of rural economy is not solely to be attributed to the want of skill in our dairy-maids; and the cause of failure is rendered more difficult of discovery, and consequently more difficult to be remedied, from an observation that the plants were nearly the same in the Herefordshire and Cheshire pastures, on which the above experiments were made: white clover abounded in each, with the crested dog-tail grass and rye-grass mixed with others in small quantities. Of such plants the pastures of Herefordshire are generally composed.

A mode of managing sound meadows and pastures has lately been tried, and attended with a great increase of produce. The grass is mown as soon as it is in blossom, and consequently previously to the formation of seed. The after-grass is not grazed until it begins to contract a yellow appearance, in the latter end of October or beginning of November. In this case the ground remains covered during the winter with a portion of dead herbage, through which the young grass springs with the greatest vigour at an early period of the succeeding spring.

8. Gardens and Orchards.

Fruit trees first extensively planted in Herefordshire in the time of Charles I., by Lord Scudamore, of Home Lacy. Orchards and hedge-row trees of the apple and pear kind are found on every aspect, soil, and under every culture. The soil best adapted to most kinds of apples, is a deep rich loam when under the culture of the plough; the Styre and golden pippin,

in particular, form exceptions, and flourish most in a hot and shallow soil, on a lime or sandstone. The best sorts of pear trees also prefer the rich loam, but inferior kinds will even flourish where the soil will scarcely produce herbage. The apples are divided into old and new sorts; each class comprises some called kernel fruits, namely, the fruit growing on its native roots, as a distinction from those produced by the operation of grafting. The old sorts of apples are those which have been long introduced, such as the Styre, golden pippin, hagloe-crab; several varieties of the Harvey; the brandy apple, red-streak, woodcock, moyle, gennet, red, white, and yellow musks; fox whelp, loan, and old pearmain; dymock red, ten commandments, and others. Some of these names are descriptive of the fruit, and others are derived from the places where they have been first found, or found in most abundance. The old pears held in most estimation are, the squash, so called from the tenderness of its pulp; the oldfield, from having grown as a seedling in a field of that name; the huffcap, from the quantity of fixed air contained in its liquor; the barland, from fields in the parish of Rosbury, called the Barlands; the sack-pear, from its richness; and the red pear, from its colour. Of more common sorts, the long-land is the most valuable, and for the general use of the farmer perhaps the best of any.

9. Woods and Plantations.

Oak very abundant, and more rapid in its growth in this county and Monmouthshire than in most parts of England, Lord Oxford's estates and Croft Castle contain the finest old trees in the county; fine woods at Foxley, U. Price, Esq.; most luxuriant oak timber and coppices at Moccas Court and Stoke Park; a curious weeping oak at Moccas. Most productive ash coppices at Hampton Court and Ledbury; cut every thirteen years for crate ware, hurdles, &c. and bring from 1*l.* to 3*l.* per wood acre, which is to the statute acre as 8 to 5. Elm trees are interspersed in the hedge-rows with fruit trees.

10. Improvements.

Draining much wanted, but practised chiefly by proprietors; watering little practised, though introduced in 1610 by R. Vaughan, Esq. of New Court, whose tract on the subject has been already mentioned. (4376.) One of the greatest experiments in this way which have been attempted of late years in Herefordshire, has been attended with complete success on the estate of T. A. Knight. By making a weir on the river Teme, with proper courses for the water, that gentleman is now enabled to irrigate two hundred acres of land, which were never watered before, with the assistance of the least flood; and one half of that quantity even in the driest season.

11. Live Stock.

Hereford cattle esteemed superior to most, if not to all, other breeds; those of Devon and Sussex nearest them in appearance. Large size, an athletic form, and unusual neatness, characterise the true sort; the prevailing colour is a reddish brown, with white faces. The rearing of oxen for agricultural purposes universally prevails; nearly half the ploughing is performed by them, and they take an equal share in the labours of the harvest. They are shod with iron in situations which frequently require their exertions on hard roads. The show of oxen in thriving condition at the Michaelmas fair in Hereford, cannot be exceeded by any similar annual collection in England; on this occasion they are generally sold to the principal graziers in the counties near the metropolis, and there perfected for the London markets.

Herefordshire not being a dairying county, breeders direct their attention to producing that form of animal best adapted for feeding rather than milking. "The whole attention of the Leicestershire breeder has been directed to the improvement of his cow; and for the use of the grazier, he has made her an excellent animal. The Herefordshire breeder, on the contrary, has sacrificed the qualities of the cow to those of the ox; he does not value his cow according to the price which the grazier would give for it, but in proportion as it possesses that form and character which experience has taught him to be conducive to the excellence of the future ox. Hence the cow of Herefordshire is comparatively small, extremely delicate, and very feminine in its characters. It is light-fleshed when in common condition, but capable of extending itself universally in a short space of time, when fattening. Experience seems fully to have proved, that these qualities in the cow are necessary to perfection in the ox; and that when the cow is large and masculine in its character, and heavily loaded with flesh, the ox will be coarse and brawny, and, consequently, unkind and tedious in the process of fattening. It may here be remarked, that there is an extraordinary difference between the weight of a Herefordshire cow and the ox bred from her; perhaps other sorts, eminent for producing fine oxen, are similarly distinguished; but it is a fact, that a Herefordshire cow will not unfrequently be the mother of an ox of nearly three times her own weight. T. A. Knight, who made this observation, recollects no instance of this great disproportion in the weight of the males and females of the long-horned cattle. That gentleman farther observes, that he is unable to discover what advantage the public have derived, or are likely to derive, from a breed of cattle which are neither calculated for the dairy nor for breeding oxen. The difference in the dairy between a good and an indifferent milking cow, on the pasture which is adequate to the keep of the latter, will seldom exceed five pounds, and if the animal be good, a very poor pasture will be sufficient; but the difference between a good and bad ox will often exceed twenty pounds, where both have consumed in fattening equal quantities of food: individuals and the public are, therefore, equally and evidently interested in the improvement of the labouring ox. Persons of little experience, Knight adds, in the breeding of cattle, may perhaps think that a sort is obtainable which will unite the two objects; but experience will convince them, that in endeavouring to

approach two opposite points at the same time, they will never be able to reach either. Where the soil is well calculated for the dairy, every attention should be paid to obtain and improve the best sorts of milking cows; and where the ox is kept to a proper age as a beast of draught, nothing conducing to his excellence ought to be neglected. A cow must, however, give milk enough to keep its calf fat, or it is disqualified for breeding a good ox; because the calf would be spoiled before it had acquired the proper age to be weaned.

Sheep. The provincial breed, the Ryeland, named from the sandy district in the neighbourhood of Ross. They lamb in February and March; but during winter, and particularly in time of lambing, the store flocks are generally confined by night in a covered building, provincially termed a cot, in which they are sometimes fed with hay and barley straw, but much more frequently with peas-haulm. Some breeders accustom them to the cot only in very severe weather, and in lambing time. The practice was derived from the Flemings, and introduced into England about the year 1660. A cross has been made between the Ryelands and the new Leicester sorts, to the

advantage, perhaps, of the breeder who is situated on good land, but certainly to the detriment of the wool. A cross between the Ryeland and real Spanish seems the most probable mode of adding to its fineness and value. Dr. Parry's experiments have been already related. (7232.)

12. *Rural Economy.*

"If a certain proportion between the price of labour and the average price of wheat could be fixed by law, so as to render the applications for parochial aid necessary only in cases of a very large family, of unusual illness, of scanty seasons, or any other real emergency; the measure, it is presumed, would be honourable to the country, would stimulate industry and fidelity, would check dishonesty, and endear to a numerous class their native soil."

13. *Political Economy.*

Roads formerly bad; now improving; materials, coarse limestone. Gloves, to a small extent, manufactured in Hereford. An agricultural society established in 1797, which has given many premiums, and done much good.

7795. SHROPSHIRE. A surface of 890,000 acres; in general flat, but with hills of considerable height on some of its margins. The soil is chiefly clay, but in part light turnip land; both are devoted to the raising of corn-crops. Breeding and dairying is also practised to a moderate extent. The greatest improver in the county is the Marquis of Stafford, whose extensive and important operations on the estate of Lilleshall are described at length by Loch, in his *Improvements on the Marquis of Stafford's Estates*, 1819. (*Bishton's Shropshire*, 1794. *Plymley's Shropshire*, 1801. *Marshal's Review*, 1819.)

1. *Geographical State and Circumstances.*

Climate. Considerable difference according to the soil and surface; more warm on the eastern side than in the middle of the county. E. winds prevail in spring, and W. in autumn.

Soil. Nearly an equal quantity of wheat and turnip land, the former rather predominant. S.W. side of the county variable; thin soil upon clay or rock; extensive tracts of hills and waste; and most sorts of soils except chalk and flint.

Minerals. Lead in granulated quartz very productive. Copper ore found but not worked. Coal of excellent quality on the eastern side of the county; lime, building-stone, chalybeate and spa waters, at different places. At Kingly Wick a spring of salt water, used for making soda at a work established at Wormbridge. Extensive iron works at Colebrook Dale, where the first cast-iron bridge was erected by Mr. Telford about 1780.

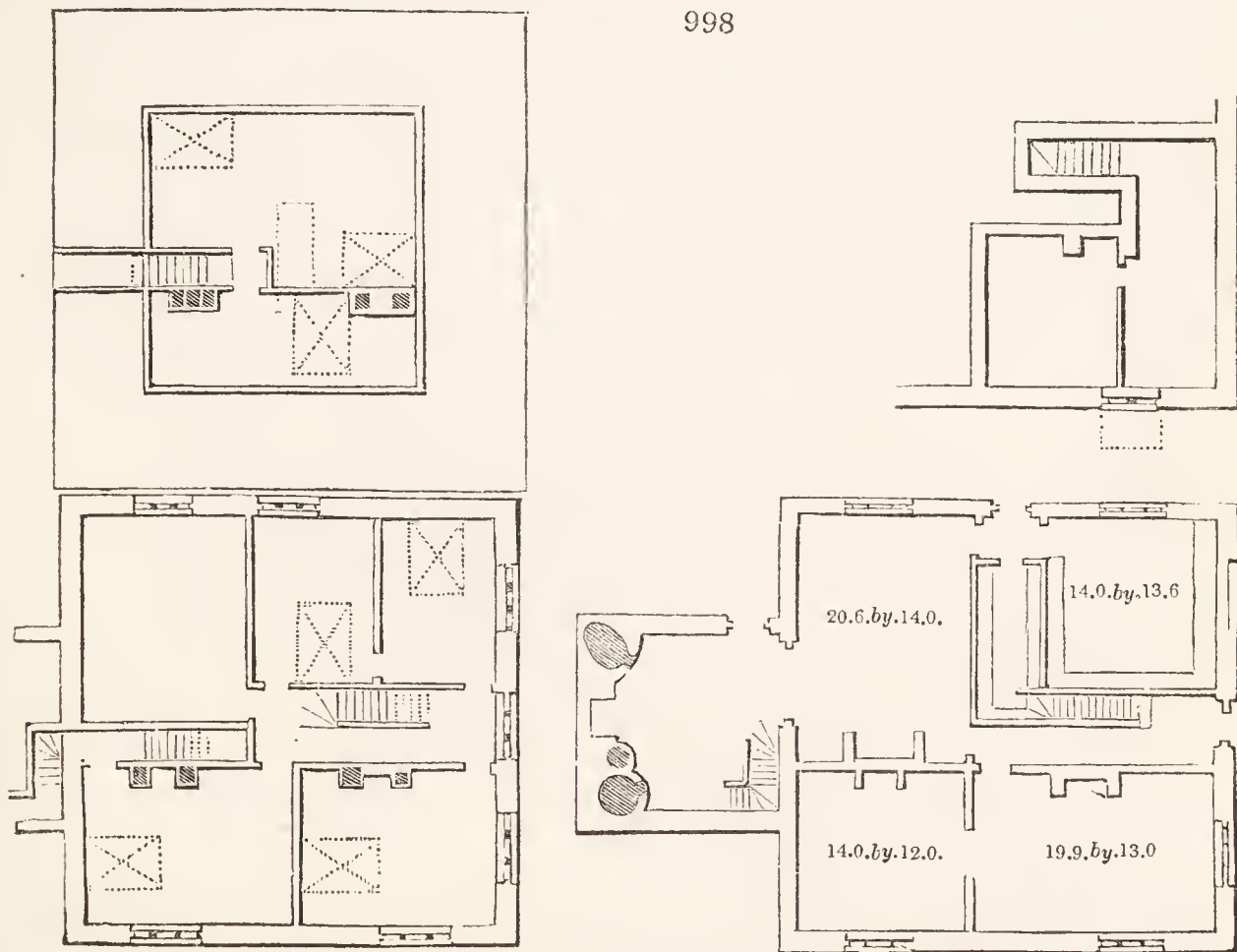
Waters. Twenty-two sorts of fish found in the Severn in Shropshire. Salmon in season from Michaelmas to May.

2. *Property.*

Estates of from 10 to 25,000 acres, and an infinite number of freeholders: yeomanry estates of all inferior sizes: much copyhold, but the lords upon some customary manors have enfranchised the copyholders upon receiving an equivalent in money.

3. *Buildings.*

Some good new mansions; above eighty of these named in old maps become farm-houses. Farm-houses generally in villages. Excellent new ones on the Marquis of Stafford's estates. (.fig. 998.)



Comfortable cottages with gardens much wanted. Some judicious observations by Plymley; prescribes no particular forms, but suggests the impropriety of making them, or indeed any other object, bear an outward appearance, intended to contradict their inward use; all castellated or gothicised cottages, all churchlike barns, or fortlike pigsties, he conceives to be objectionable. They are intended to deceive, and they tell you that they are intended to deceive. It is not pleasant to encourage any thing like deceit, but in these instances imposition effected is rarely gained; it amounts only to imposition attempted; or, could the deceit succeed, it would only present a prospect with fewer proprieties about it than there really are. Almost every species of country building has a good effect, if properly placed and neatly executed; and what are the least ornamental, or indeed the most disgusting, of their appendages, cease to shock when supported by the relative situation they stand in, showing their necessity and their use. A dunghill in a farm-yard creates no disagreeable idea; but connected with a Gothic gateway or embattled tower, it is bad. Cattle protected by the side of a barn form a picturesque group; but sheltering under a Grecian portico, the impropriety is

glaring. Linen hanging to dry on the hedge of a cottage garden may be passed without displeasure; but the clothes of men, women, and children surrounding the cell of an anchorite, or the oratory of a monk, have their natural unseemliness increased by the contrast. On the other hand, a fine-dressed lawn with miserable cottages may be compared to the laced clothes and dirty linen some foreigners were formerly accused of wearing. The whole of a gentleman's estate should be his pleasure-ground: the village should be one object in the scene; not shut out from it. There may be a little more polish about the mansion, but it should not be an unnatural contrast to the surrounding objects. The face of no country is bad but as it is disfigured by artificial means; and the cheapest and best improvement is merely to remove what offends, and to take care that the buildings or fences that are wanted are neat and appropriate, exhibiting distinctly their real intention. Plymley is a friend to single cottages, because two families under one roof may have more causes of contention arise between them. On the other hand, in illness poor people have frequently the merit of forgetting their differences; and then the assistance they are inclined to give each other is made more easy by near-

ness of situation. It is possible, however, where two, or even three houses are joined together, to contrive the gardens in such a manner that there may be little interference; and sometimes three neighbouring families may do better together than two.

4. Occupation.

On the borders of Wales the farms are small, many not exceeding twenty acres; on the east side of the county from one to 500 acres: farmers in general very industrious; work along with their servants; wives brew, bake, dairy, and at spare hours spin, and get up a piece of linen cloth for sale every year. Leases for lives formerly very common. Bishton of Kilsall has taken great pains to prepare printed leases, which answer very well. The term he recommends is seven, fourteen, or twenty-one years. By being printed the farmer can read them at his leisure.

5. Implements.

Plough with two wheels, drawn by four or five horses, or six or eight oxen, in the strong lands, and two horses with a boy to drive in the turnip soils. Various improved implements and threshing-machines: some excellent mills on Lord Stafford's estates, driven by steam.

6. Enclosing.

Much practised, and still going on. Plashing hedges is usually very ill done in Shropshire; it is a business which requires great nicety and judgment, and has the most ignorant operators to perform it in general; who in the first place cut downwards, through mere idleness, instead of upwards, and so expose the heart of the plant to the weather. Many miles of hedges lately planted on the Stafford estates.

7. Arable Land.

Following very badly done on the strong lands. Common crops of the county wheat, barley, oats, peas, and turnips. Peas found not to boil well unless grown on a sharp gravel or sand; those grown on clay given to pigs and horses. Some hemp and hops cultivated.

8. Grass.

Some natural meadows on the Severn and other rivers; not much attention paid to them. Artificial herbage and grasses grown on the turnip soils.

9. Gardens and Orchards.

Many farmers have small orchards, from whence they make a little cider for home consumption; and on the confines of Herefordshire and Worcestershire the orchards are larger, and cider is made for sale.

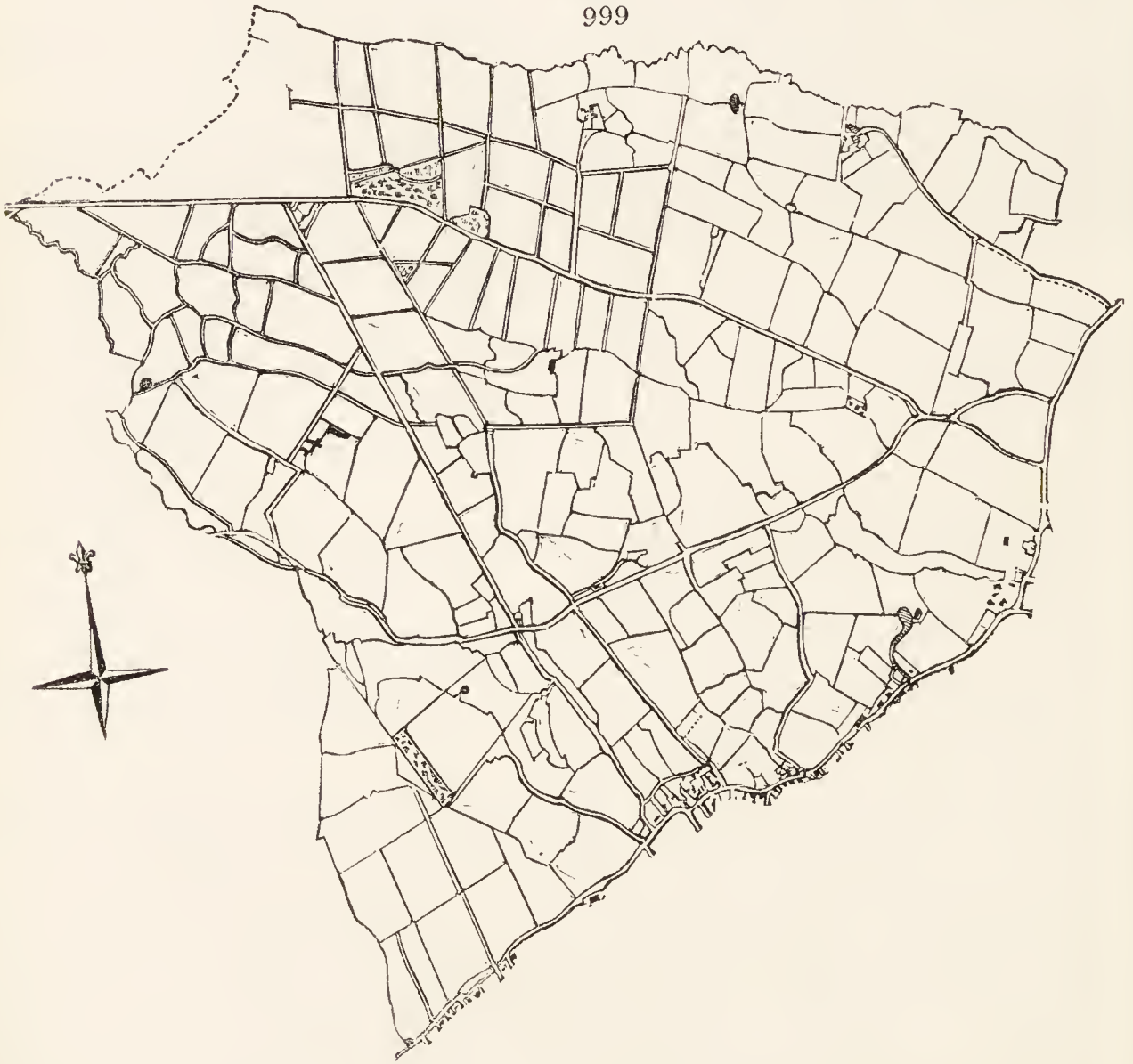
10. Woods and Plantations.

A good deal of hedge-row timber, and some fine oak woods; also numerous young plantations. Narrow-leaved elm reckoned an excellent hedge-row tree, but the broad-leaved better timber, and less difficult as to soil and situation. In this county few persons will bury their relations in any but the best oak timber, which contributes much to its scarcity.

11. Improvements.

Marl used, and some irrigation. A good deal of draining done with brick, stone, and faggot wood. Some bogs drained in Elkington's manner. On the Lilleshall estate of Lord Stafford (*fig. 999.*), in 1816 and 1817 there has been executed about 17,000 yards of embankment; 27,000 yards of water course deepened and scoured; 46,000 yards of main ditches made or

999



deepened; 315,000 yards of fence-ditches deepened, scoured, and straightened: 49,000 yards of old fences stocked; 30,000 yards of new quick fences made; 21,000 yards of turf draining; and 462,000 yards of under-ground draining, laid with tiles and filled with stones; besides the erection of many new farm-eries of the most commodious plans and substantial execution. But to have an adequate idea of these and other improvements effected by this munificent and patriotic nobleman, it is necessary to peruse the very interesting work of Loch already referred to.

On the Wildmoor estate of Lord Stafford (*fig. 1000.*) excellent roads have been formed; so that several parts, before inaccessible in winter and during wet weather, may now be approached at all times with ease. The effect, as Loch observes, has thus been to add so many acres to the estate. But the most considerable work executed upon these estates is the drainage of the extensive district alluded to, called the Wildmoors. The extent and nature of this improvement is such as to deserve a particular and detailed description. Some adjoining properties have benefited by this work, and contributed to the expense of it, which was done under the authority of an act of parliament; but as almost the whole of the land belongs to the Marquis of Stafford, and the expense having been chiefly borne by him,

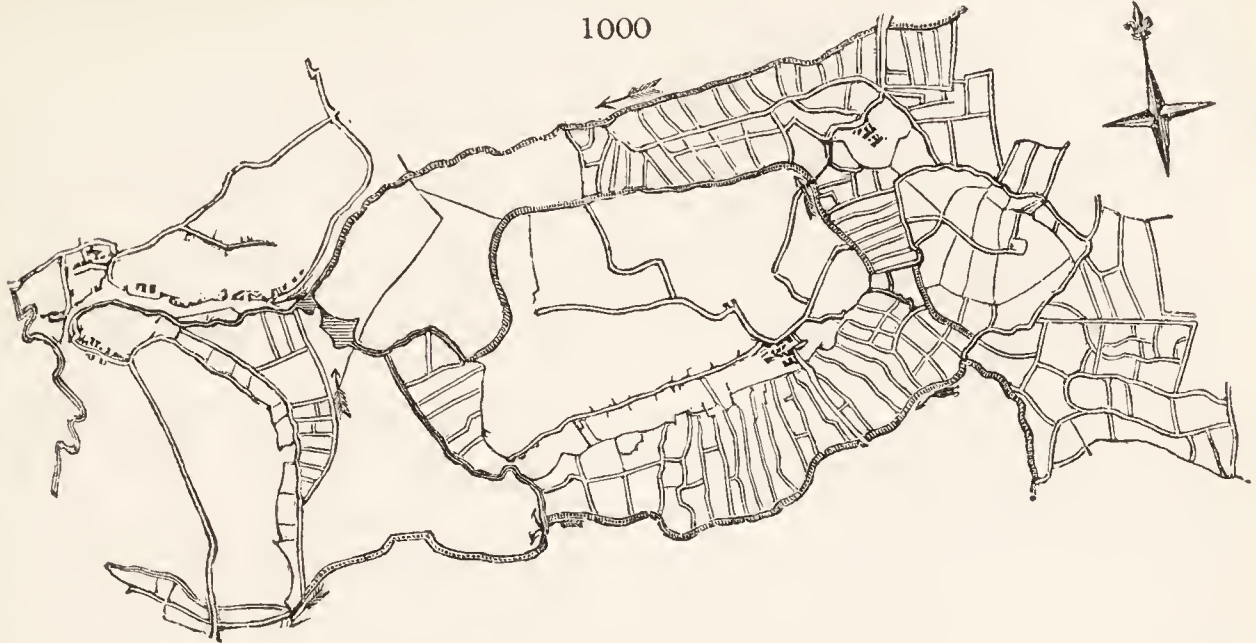
the direction of its progress, and its preservation hereafter, is entirely vested in a surveyor chosen by his lordship.

These moors consisted of an extensive tract, amounting, with the land similarly circumstanced, to near twelve hundred acres. The soil is composed of a fine black peat, incumbent on a bed of red sand, full of water. They are bounded chiefly by the upland part of these estates, and surround the parish of Kynnersley, which also belongs to it, and which is composed of some of the finest turnip and barley soil in the kingdom. They had evidently formed the bottom of an extensive lake. The different brooks from the surrounding country held their course through them. These brooks are known in the country by the name of *Strines*, being distinguished from each other by the name of the places from which, or past which, they flow. Their course to the Tearn (which river drains the whole of this country into the Severn) was devious and crooked in the extreme, injuring to a great extent the land through which they ran.

A great proportion of these moors was occupied by the tenants of the adjoining farms, who turned their stock in upon them for a portion of the summer season only. During the rest of the year it was impossible to use them. They afforded but a small quantity of food, and were in most places so wet that it

was at all times difficult to walk over them, it being necessary to select the hardest places to step on. They were covered with water after almost every severe rain, owing to which the

inhabitants of the neighbourhood were subject to frequent attacks of ague. The adjoining lands besides, to an extent exceeding six hundred acres, were kept in nearly a state of

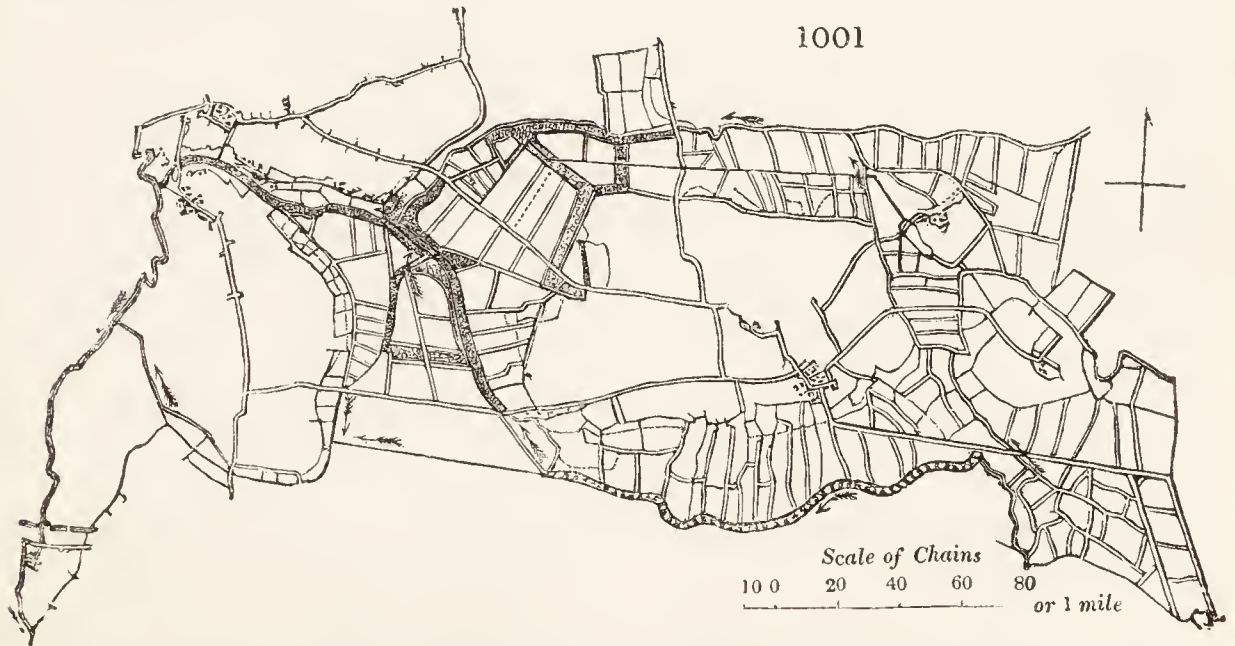


nature, owing to there being no level by which they could be drained while this extensive district continued subject to such inundations.

The difficulty which occurred in draining this tract of land arose from the want of level, and from the river Tearn being pounded so high by the mill-pools as to throw the water back to a great distance upon the land. The plan for draining this extensive district was extremely well conceived and judiciously laid out, in the double view of securing this object and of interfering as little as possible with private property and the existing establishments situated on the Tearn. It was suggested by John Bishton, Esq., the first commissioner under the Act. The great object was to gain as much additional level as would create a run throughout the whole extent of the moorlands. This was to be obtained by beginning the cut which was to carry off the water a considerable way lower down the Tearn than the water had hitherto been discharged into that river; and a good deal below the mill-pool at Long, which occasioned this pondage. The original courses of the strines were straightened and widened, but they were still made to convey the water from the uplands, and to discharge them into the Tearn in their original direction. To prevent them overflowing the adjoining lands, and to cut off the effects of the back pondage of the Tearn on the upper moors, these brooks were embanked for the whole length of their course through the Wildmoors. These are technically called argue banks. At the back of these banks deep ditches were carried, but in a more direct line than

the course of the strines. Into these ditches the drainage of the moorlands is emptied. The level which was thus brought from the river Tearn, from below Long Mill, was carried in a tunnel under the Shrewsbury canal, and was conducted below the several strines in siphon culverts, and thus communicated with the ditches described as having been made behind the banks which confined the waters of these brooks.

In some instances it has been necessary to construct one set of culverts over another, in order that the waters coming from the uplands may be kept in the several brooks through which they had constantly flowed, and that this water flowing from the uplands might not fall into the back drains; it being again explained, that the water flowing from the higher grounds is still confined to the original strines or brooks on an upper level; the drainage water alone of the moorlands being thrown into the back drains. Thus has a great additional level been obtained, and the whole of this district is now entirely relieved of water, and such a thing as a flood has not been known for years. This district is in some instances so flat, that the old course of the Preston strine, which formerly conducted the water of that brook in one direction, has with little difficulty been made a part of the drainage, and to carry the drainage water in exactly the contrary direction, a new channel having been cut for the strine. Taking advantage of this drainage, main ditches upon a regular system have been carried into all the neighbouring parts of the estate, thereby enabling the landlord and the tenant to execute various other improvements.



This district has been subsequently divided into regular enclosures, by great ditches, which fall into the main drains; and wherever it has been possible, these ditches have been made to serve this purpose, as well as that of a fence to the new roads which have been constructed across these moors. In one instance, one of these roads has been carried in a straight line for about two miles. On each side of this road trees have been planted, at regular distances, which will soon form one of the finest avenues in England. These moors have besides been all regularly under-drained by turf drains, which stand remarkably well. In the different ditches are placed flood-gates, to pound back the water during the summer, preserving the meadows in a state of perpetual verdure. The water is let off at least once in every fourteen days, and being drawn off with as much velocity as possible, it scours and keeps clear both the ditches and the underground drains; — the mouths of these latter are all defended with tiles. The moorlands have been greatly improved by very heavy and repeated rollings and top-dressings; and their value as let to a

farmer, in many instances, is fully doubled. This improvement has cost a very large sum of money; which was increased beyond what was necessary, owing to the inefficiency of the late surveyor belonging to the commission, which is not yet closed. The drainage, however, has lately been put under a surveyor (Lewis), approved of by Lord Stafford in terms of the Act, and the expense is diminished, and the whole put in better order.

A very rapid improvement has taken place on these lands. In place of being the very worst part of the estate, they are rapidly becoming equal to the best and finest meadows on it. In order to shelter them from the blasts which come round the Wrekin, from the Welsh mountains, they have been intersected with various plantations. A plan of the Wildmoors previous to (fig. 1000.), and another subsequent to, this improvement (fig. 1001.), will serve to give an accurate notion of what has been done; the whole being well worthy the examination and inspection of an intelligent agriculturist and improver. (Loch, p. 226.)

12. *Live Stock.*

Cattle of mixed breeds: some dairying, chiefly for butter to the manufacturing towns; some cheese, but not very good. Calves raised as stock, and sometimes suckled for veal. Sheep in breeding flocks of various kinds. Stock in general neglected as to improvement; all sorts of crosses permitted, so that the original breeds of sheep and hogs are now lost. Pork and bacon are much used among the poorer people, when they can procure them; therefore the sort which is to be fed with the least trouble is to be preferred. A mixture of the Shropshire and Chinese has, in this respect, been found to answer for bacon, and a cross of the wild breed for pork.

Geese, reared on the commons, and sold to farmers, who fatten them on their stubbles.

Turkeys, reared in large quantities by some farmers, and

7796. STAFFORDSHIRE. 765,000 acres of hill and dale, some parts rugged and others smooth, but on the whole more a mining and manufacturing than an agricultural county. The Marquis of Stafford, Lord Anson, and the Marquis of Anglesea, are the chief improvers. Excellent markets for produce within the county in consequence of the numerous manufacturing towns and villages. (*Pitt's Report*, 1808. *Marshal's Review*, 1813. *Loch's Improvements*, 1819. *Edin. Gaz.* 1827.)

1. *Geographical State and Circumstances.*

Climate. Air sharp and cold, and inclining to wet; annual rains thirty-six inches; those of London twenty or twenty-one inches; of Upminster, in Essex, nineteen inches and a quarter; Lancashire forty-two; of Ireland forty-two to fifty. Annual rain on the west side of the kingdom double that on the east side.

Surface. In the north side of the county hills arise, forming the commencement of a ridge, rising gradually higher and higher into Scotland, under different names: here called Moorlands, then Peak, then Blackstone Edge, then Craven, then Stannmore; and then, parting into two horns, called Cheviots.

Soil. Very various; about one third of the county strong loam or clay; one third mixed soils of almost all sorts, and the remainder light, calcareous or alluvial; no chalk.

Minerals. Valuable and extensive; 50,000 acres or upwards of coal. Iron ore and lime of unknown extent.

2. *Property.*

Largest estates 10,000*l.* a year, and many of all sizes, from that amount down to 40*s.* a year. Attorneys generally the managers, but some excellent examples of gentlemen of from 500*l.* to 5000*l.* a year managing their estates themselves; residing on them, and cultivating a part, and giving every encouragement to their tenants.

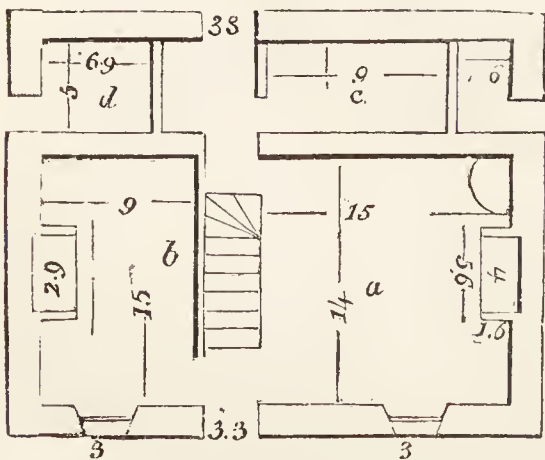
3. *Buildings.*

Some noble mansions, as Trentham, Beaudesart, Ingestree, &c. Excellent farm-houses constructed on some estates, as Trentham, Lord Stafford's; but the majority, as in other counties, bad, and badly situated. A farm-yard has been constructed at the family seat of the Ansons, for a demesne farm of 2000 acres. It was built by S. Wyatt, of London, and consists of the farming steward's house at one end; a range of building along one side contains a brewhouse upon a large scale, a water corn-mill for the family and farm use, and in which corn is ground for the neighbouring poor gratis, and a malt-house: the opposite side and end are occupied by stalls for feeding cattle, store-rooms, stables, and other appendages; and in the middle of the yard is a very complete hoggery, built of large stones set edge-ways, and covered with slate, with a boiler for heating hog-food, a cold bath supplied by the mill stream, for giving an occasional swill to the young pigs. In this building a number of hogs are fattened on dairy refuse, boiled roots or vegetables, pulse, ground barley or bran, supplied by the mill near at hand. At some distance above is the stack-yard and barns, where a powerful threshing-machine is worked by the same stream that afterwards supplies the garden, and turns the corn mill in the farm-yard.

4. *Occupation.*

Farms of all sizes, from twenty-five to 500 acres; many consolidated since 1795. Some very good cottages with gardens, and containing comfortable and commodious accommodation for agricultural or manufacturing operatives. A specimen of one is given (*fig.* 1002.), which contains a living-room (*a*), working or lodging room (*b*), pantry, dairy, cellar, &c. (*c*), cow-house (*d*), with a water closet, and three bedrooms over. Leases generally granted for twenty-one years. Little made by farming unless

1002



with a combination of all, or most of the following circumstances:—First, an easy rent; second, a pretty good and extensive farm; third, economy and industry; and fourth, length of time. In the present system of farming, at a moderate rent, the writer of this knows from experience, that it requires not only the most diligent industry, but also the most prudent economy, to keep the balance on the right side. To which Marshal adds, "I have rarely found a farmer making a fortune by his profession alone, unless on fresh land, on virgin marsh, old grazing-ground, ancient sheep-walk, or well soiled common; a fortune,

sold to higlers, who drive them to Birmingham and other large towns. Markets in general well supplied with fowls. It is to be lamented that they are generally carried alive to market. Death is no misfortune to an animal that has no previous apprehension of it. But poultry, carried in bags or baskets to market, have several hours of previous suffering, and the burden and trouble of carrying them thither seem much increased thereby.

13. *Political Economy.*

Roads generally bad; various canals; trade of Shrewsbury, flannel, and Welsh webs, used for clothing for the slaves in the West Indies and South America. Manufactures in the county numerous; iron, pottery, porcelain, glass, dyeing cloth, woollens, flannels, linen, gloves, &c. An agricultural society at Drayton.

I mean, any way resembling that which, with the same ability and industry, and with a small share of the outset capital, he would have been making by trade, manufacture, or commerce."

5. *Implements.*

Very various; double furrow-ploughs drawn by four horses, a good deal in use in the light lands. Excellent threshing-machine, and various new implements introducing by proprietors, and especially by the Marquis of Stafford.

5. *Arable Land.*

Most annual field-crops cultivated, including hemp and flax.

7. *Grass.*

Meadow on the rivers and brooks, and artificial grasses sown; feeding in general preferred to dairying.

8. *Gardens and Orchards.*

Common to many farm-houses; but few or no sale orchards, and scarcely any fruit crushed for liquor.

9. *Timber and Woodlands.*

Best-timbered estate Blithfield Park, Lord Bagot; the park contains many hundred trees of extraordinary bulk, containing from 200 to 400 feet of timber each; much of it is mentioned by Dr. Plott as full grown in 1686. Chillington and Beaudesart also remarkably well timbered. The remains of Needwood forest, chiefly remarkable for its beautiful hollies. On the whole the country abundantly wooded. Sneyd's coppices cut once in six years to make crates and large hampers for the potteries.

10. *Improvements.*

Irrigation and draining practised, the former only to a moderate extent. Jessop, the engineer, suggests that nine parts in ten of the waters of the kingdom at present run away in waste, a great part of which might be usefully employed; nay, further (putting expense out of the question), that every stream in the kingdom may be made to run equally through the whole year. This position, however extraordinary, is easily demonstrable; for if, upon any given stream, one or more reservoirs be made, capable of containing its flood water, and through the dam or dams be laid a pipe or pipes, whose apertures will just discharge the average produce, the business is done: and though there may be no probability of this business being ever brought to so great a nicety, yet from hence some idea may be formed of the prodigious extent to which improvements by water may be carried.

Great and radical improvements have been effected on the Trentham estates. The first object was the laying the lands together, in farms of considerable extent, varying in size according to the nature of the soil, and other circumstances. In effecting these necessary changes, wherever the old tenant was removed, which was done as seldom as possible, he was, unless he took a farm elsewhere, accommodated with his house and his best grass crofts for his life, at a low and inadequate rent; and in every case where it was possible to treat with the person beneficially interested in the lease, and whose continuance in the farm was incompatible with the new arrangement of the land, his interest was purchased either for an annuity or a sum of money, to enable him to look out for, and to stock a new farm. The size of the farm being thus enlarged, it was necessary to enlarge the size of the inclosures, and to lay several closes into one, and, where possible, to give them a more regular and uniform shape. This arrangement enabled the landlord to get rid of the long useless lanes, by which a considerable addition to the number of arable acres was acquired.

In order to give each tenant every advantage in draining his farm, the great lines of ditches were executed by the landlord; and wherever it was possible, these were made the boundaries of the farms. Thus the whole drains on the estate were conducted according to one uniform plan, by which the system of drainage was rendered much more complete, and the interests of the whole, and not that of any individual tenant, were consulted, nor was any one allowed to interfere with the interests of his neighbour. Such a perfect system will have the effect of rendering the condition of these estates more complete in this respect than that of any other in England. Attention has also been paid, in the execution of these works, to make the water available for the construction of water-meadows, and for impelling the threshing-machines of the respective farms.

In consequence of the complete state of ruin in which the farm buildings on these estates were found, it was necessary to incur a serious expense in constructing new ones. In this way it has been necessary to erect thirty-seven new, and to repair throughout eight other, extensive sets of farm offices, besides the smaller repairs which such estates necessarily require. They have been executed in the most substantial manner. They are built of the best possible brickwork, covered with tiles or slates; and their cost, including the expense of those thoroughly repaired, may, on an average, be stated at from 1500*l.* to 1600*l.* each.

We have already given examples of these buildings (2955. and 2957.), which are remarkably complete in design, and substantial in execution; and several of them are furnished with

threshing-machines, driven by water or steam, a thing rare in England, excepting in Northumberland. It is believed, Loch observes, that they unite as many advantages with as few faults as any buildings of the sort, and that they will supply useful hints to others.

It had been at one period the custom to permit *huts* to be erected in all parts of the estate. These huts amounted in number to many hundreds; they were inhabited by the poorest, and, in many instances, by a profligate population. They were not regularly entered in the rental book, but had a nominal payment fixed upon them, which they paid annually at the court leet. These cottages were built on the sides of the roads, and upon the lord's waste, which was gradually absorbed by the encroachments which the occupiers of these huts made from time to time, by enclosing that which lay next to them. They gradually fell into the hands of a body of middlemen, who underlet them at an extravagant rent to the actual occupiers. In this manner the poor people were oppressed, and the landlord was in danger of losing his property.

To remedy the evils arising out of this system, the cottagers were made immediate tenants to the landlord, and their rents made payable at the half-yearly audits; an arrangement perfectly satisfactory to them, as they were no longer exposed to the vexations of an intermediate possessor, and, in many instances, their rents to their landlord were less than they had been accustomed to pay to those from whom they had hitherto held their houses. Since they have been placed in this situation, greater attention has been necessarily paid to their conduct and character, as well as to their wants. As they know that their good conduct will now be noticed by, and meet with the approbation of, their landlord, a considerable improvement in their habits has taken place. There can be no doubt but that these important and necessary arrangements were far from being agreeable to those who suffered from them. In altering such a system, not only was the direct interest of the existing middlemen affected, but also the expectant interests and influence of many who contemplated the chance of one day benefiting from their favour. These were not few, and it did not always happen that the person who expressed his dissatisfaction loudest, was the one most likely to succeed in his wishes; and in proportion as this object was near its completion, was the vexation and discontent of those who were disappointed. To the larger farms some of these cottages have been added, to enable the occupier to put into them married farm-servants, who have thus a great inducement to behave honestly and industriously, and to attend with good will and zeal to the interest and the business of their master. It is by giving such inducements as this, and by making them feel an interest in acting right, that this most invaluable class of labourers can alone be maintained and supported.

What has been done by the proprietor, has been well seconded by the exertions of his tenants. A more respectable and enterprising body of men do not exist; and, while they are in a better situation of life than a great body of this class, they have not allowed themselves to forget, that it is by a constant attention to their business, by their keeping in the line of life to which they belong, and never attempting to commit the management of their affairs to bailiffs, that they have gone on steadily improving and bettering their condition. In the knowledge of stock, in their capacity as excellent market-men, in the management of their grass land, and in the cultivation of and in cleaning their lighter soils, they are surpassed by no farmers in the kingdom. The rotation they follow is the Norfolk husbandry; and in the cleanness of their crops, and the excellence of their drill turnips, they cannot be surpassed. The breadth of turnip annually sown is very great, and the rapidity with which they have adopted the drill system of husbandry is as creditable to them as it is satisfactory in the result.

Except ploughing with too many horses, and not being sufficiently active in getting in their harvest, they have fewer practices to abandon, and there are fewer things which they have to adopt from any other of the well cultivated districts of the island, than is generally the case. Every means has been used to explain to them the advantages of ploughing with fewer horses; and there is every reason to expect that their good sense will soon see the propriety of these suggestions, as many of them have already adopted this system. The fact is, that the difficulty consists in being able to persuade the ploughmen to adopt it as the labour of holding the plough is more severe: it is impossible for one or two individuals to contend successfully against the feelings of a country; but when undertaken by so numerous and wealthy a tenantry, supported by the influence of the landlord, these feelings must speedily give way.

This mode of ploughing has made rapid progress at Trentham. The reason of which is, that it is more generally admitted, that this system is calculated to suit the stiff better than the lighter soils, inasmuch as two ploughs, drawn by two horses abreast, do much more work than a double plough, drawn by four horses, can do in such soil: the superiority of the work, also, is very conspicuous. On the other hand it is argued, and with some apparent force, that on light soils the double plough, drawn by four horses, and guided by one man, can do as much work as two ploughs drawn by two horses each, and guided by two men. In this way the labour of one man is saved. It must be admitted that the argument would be in favour of the double plough, were it not that the work it performs is neither so neat, so perfect, nor can it plough so deep as is done by the two horse system. It is remarkable that this mode of ploughing with two horses should be confined to the eastern parts of England, from which it was adopted, at no very distant period, in Scotland, where the ploughing with a number of horses yoked along with oxen existed to an extent never practised in any part of this country.

In order to encourage these men to make this change, an annual ploughing-match has been instituted, at which prizes are distributed to the best ploughmen. The effect this has already had is very considerable; and at the exhibition in October 1814, no fewer than fifty ploughs started for the premiums. The progress of such a system must be also slow; as it cannot be expected that the tenants should at once lay aside all their old implements, and purchase new. The difficulty of procuring good ploughs operated much against the adoption of this mode of ploughing. In removing this inconvenience, there has been established, both in Shropshire and in Staffordshire, a manufactory for the construction of the more improved implements of modern husbandry: and it is strongly recom-

mended to the persons who have been thus established, that they should take their apprentices entirely from the lads of the country.

It is in the management of their stiff lands that tenants are most defective. Of late, however, they have made so great exertions in draining their lands, that it is hoped they are beginning to adopt a better system. The defect of their management consists in their ploughing very shallow; the effect of which is, that the depth of soil is not sufficient to protect the roots of the plant from being chilled with the cold and wet (which is upheld by the impervious nature of the subsoil), when the ground is wet, and exposes it to the too rapid action of the drought when the weather is dry. To plough deeper is, therefore, the first, the most simple, and the most important improvement which can be adopted in these soils.

They also, until lately, hurt these cold lands by making use of a large quantity of a bad sort of red clay marl, which they dug out of every field. The effect produced was, to increase the tenacity of the soil, and to render it still less fit for the purposes of agriculture. Of this fact, all the intelligent part of the tenants are themselves convinced, though some of those who are still wedded to their old customs, lament the regulation which prohibits them from using this article. On those farms where the inclosures have been entirely renewed, and where, in consequence, a portion of several of the ancient inclosures have been thrown into one close, the bad effects of this system of marling is perceived in a remarkable degree, and a distinct line in the appearance of the crop, points out with precision the land which had been formerly so treated, from that which had not. The consequence of this prohibition has been, that the tenants have applied themselves much more to the use of lime as a stimulant, which has repaid them, as might have been expected. It has also put a stop to the rapid deterioration of property, which was occasioned by the digging of the pits, which every where disfigure and destroy a considerable portion of the farms of this district.

To level down these marl-pits, and to render them again fit for the purposes of husbandry, has been an object of great attention. In this way there was applied the labour of a great proportion of the parishioners, to whom, from time to time, employment had been afforded, in those years when the circumstances of the country rendered such an exertion of the landlord's bounty necessary. This was more particularly the case in 1817; in which year a vast body of men was employed on each of the Marquess's estates.

In another particular, the management of the stiff soils might be considerably amended; which is, in the mode of working the fallows, which are left too generally to grow full of weeds, in place of being cleaned as they ought to be. The muck, also, is laid on at an improper season of the year, by which its good effects rather go to encourage the growth of weeds, than to improve the crop. At Trentham, the strong soils are of a far superior quality, fit in every respect for the most improved system of wheat and bean husbandry. But the lands were so much subdivided, and the capital of a large proportion of the tenants, until lately, was so inadequate to the right cultivation of their land, that no improvement could take place or be expected, and this estate remained stationary, amidst the general progress which was so conspicuous in the other parts of the county. These defects have been remedied in both instances; and the introduction of some skilful farmers from Shropshire and Cheshire, at Trentham, has given rise to that spirit of enterprise which at present characterises the tenants of these estates, and which must prove so beneficial to the country, by the additional surplus produce which will be brought to market.

The rotation which they followed, on both estates of the stiff soils, was, fallow, wheat, oats, clover. That is now altered, by clover being substituted after the wheat; and an attempt has been made to induce them to try a six-shift course of husbandry, by introducing beans into their rotation. Little progress, however, has as yet been made in this experiment. To this they have considerable objection, which arises from the defective mode of cultivating their bean-crop. In the first place, they are unwilling to sow them in drills. They are, besides, longer in planting them, and allow them to stand later in the year than they ought to do. The consequence is, that their crop is often damaged, and the nutritious matter of the bean-straw is entirely lost. They cannot be persuaded, therefore, that it forms an excellent and nourishing food for horses and cattle; and the complaint that they make of its being an exhausting crop is quite correct, in consequence of their permitting it to stand so long upon the ground.

One improvement the tenants have paid much attention to, and a more valuable one they could not adopt, which is the construction of water-meadows. They have lost no opportunity in making use of whatever water they could obtain for this purpose. They were allowed the rough materials to construct the flood-gates, and the example was shown them as to what could be done in this respect to a very great extent at Trentham. The value of this improvement is well known to every experienced agriculturist in England, and no opportunity should be lost in taking advantage of every circumstance to promote its adoption. There has been lately finished a new water-meadow on the home farm at Trentham, at the expense of about twenty pounds an acre, which will now let for near four pounds an acre, besides the advantage derived to the adjoining upland. This meadow was not worth ten shillings an acre previous to such an improvement. It consists of a small deep dingle, with steep banks, in which a copious spring rises near the top: the upper part being formed into a fish-pond. From this head the water is conducted on the different levels on each side, with the proper catch-water drains carrying the water round the various knolls. The whole being adorned by some fine trees, it forms for its extent a very perfect union of useful and ornamental farming. It shows how much may be made of such a piece of land, incapable of any other sort of useful occupation.

Much money, however, in this neighbourhood has been thrown away by watering land which has not been previously thoroughly drained; this latter improvement is the foundation of all others. Another mistake has also been fallen into, by attempting to convert into water-meadows peat soils, without first bringing them to a proper state of consistency by means of repeated heavy rollings and top-dressings. A proportion of ten acres of water-meadow to every hundred acres of pasture or arable land, adds at least two shillings and sixpence an acre

to the value of every acre of such a farm, in addition to a fair rent being put upon the meadow.

The attention and influence of Lord Stafford has been used in whatever way it could be employed beneficially in extending the comfort or advancing the good behaviour of his cottagers; a conduct so characteristic of the great and wealthy proprietors of these kingdoms, that it must ever distinguish them in the history of human benevolence.

Schools, wherever they have been necessary, have been encouraged, either aiding them by subscription, or by granting the accommodation of school-houses. Two Banks for Savings, one at Lilleshall and another at Trentham, of which Lord Stafford is the treasurer, have been established, and the whole details are conducted by his managers, assisted by the parochial clergymen and the principal tenantry, and their success among the agricultural labourers has been very gratifying.

The charities of this family are worthy of an English nobleman; and during the residence of the Marquess and Marchioness at Trentham, there is distributed daily to every poor object, who is travelling along the road, and who applies for the same, a portion of good wholesome bread, in quantity about fourteen ounces to each full-grown man, and less in proportion to women and children, with a pint of good table-beer. The number of people who received this donation in 1819, amounted to 9504 men, 2376 women, and 1789 children, consuming 1590 loaves, and 1703 gallons of beer. From this charity are excepted all soldiers and sailors receiving the King's pay, all persons residing within the parish of Trentham, or in its immediate vicinity. Other distributions take place on particular occasions; for example, to those who reside in the parish, annually on St. Thomas's day, there is a distribution of a certain quantity of beef to the poor. During 1819, there were 12,785 quarts of rich soup, and above 8500 quarts of milk, distributed within the parish, besides 14,154 quarts of milk given away under the head of allowances. Such facts are strongly illustrative of the beneficial effects derived to the poor from the residence of the great families of England on their respective estates.

The foregoing statement would have been given with some hesitation, had not the facts been of a nature rather to exhibit and illustrate the character and extent of the charities distributed by the great families of England in general, than as being at all peculiar to the instance to which the details belong; and these facts may help to explain to foreigners the nature of the connection which exists between the richer and poorer classes in this country.

The town of Lane End, one of those which compose the Staffordshire potteries, is partly situated on, and is partly contiguous to the east end of the Trentham estate. The inhabitants being ill supplied with water, carried in barrels, they petitioned to be provided with this necessary article, which request has been complied with; and this town, after a very considerable outlay, now enjoys a regular supply of water, conveyed in iron pipes.

7797. WARWICKSHIRE. A surface of nearly 639,760 acres, mostly flat, but generally rich in soil and beautiful in appearance. It is chiefly a corn county, and produces excellent wheat; but also many fat cattle, and formerly much cheese. There are no distinguished agriculturists in the county; but it has produced more good to agriculture than many others, by giving birth to Elkington, who gave rise to much discussion on draining. (*Wedge's Report*, 1794. *Murray's Report*, 1808. *Marshal's Review*, 1813. *Edin. Gaz.* 1827.)

1. Geographical State and Circumstances.

Climate, mild and healthy. S. W. the prevailing winds: effects of an easterly variation felt till the middle of May, and vegetation checked; not, however, by excess of damp or frost.

Soil, chiefly clay or sand, marl, and limestone. The portion of sandy or moorish soil very small. The tract of land called the county of Coventry is a rich, red, sandy loam, chiefly in grass. The land near Birmingham is generally either sand or stiff clay.

Minerals, coal, limestone, freestone, iron, blue flagstone, marl, blue clay, and soapy clay, which the late Earl of Warwick attempted to prepare for sale as a soap.

2. Property.

Largest estate Stoneleigh, Chandos Leigh, Esq., 25,000 acres; but a great variety of extent, and some curious and absurd tenures.

3. Buildings.

Warwick Castle and Ragley first-rate edifices. Old farm-houses built of mud and timber, and frequently at the extremity of the farms. The Duke of Buccleugh, at Dunchurch, has constructed some good farmeries.

4. Occupation.

Farms from 80 to 500 acres; 150 the average size; on the increase. Farmers in general exceedingly shy and jealous; one, considered as at the head of his profession, told Murray "he did not see any advantage the county of Warwick would derive from such a survey; that it must do a great deal of hurt instead of good; and that such being his opinion, he declined giving any information on the different heads of queries put to him." Lands generally held at will, but very low rental. Cheap farms, in general, are a drawback on industry and improvements: farmers that have cheap farms may farm well; but those that have dear farms must farm well, or their career will soon terminate.

5. Implements.

Ploughs the double and single Rotherham with wheels, the double drawn by five or six horses in a line, the single plough by three and four, or five horses in a line, and in both cases with a driver. Small's plough, with two horses abreast, and no driver, the reporter remarks, would make better work, and do more of it. Some winnowing and threshing machines in use by proprietors.

6. Tillage.

Large crooked ridges gathered very high with a small one between; go only one yoking per day throughout the year. Fallowing general, and then two white crops.

7798. LEICESTERSHIRE. 522,240 acres of gently varied surface and fertile soil; distinguished for its pastures, and for the progress that has been made in the improvement of cattle and sheep. It is the county of Bakewell, whose name will ever stand at the head of breeding farmers. (*Monk's Report*, 1794. *Pitt's Report*, 1809. *Marshal's Review*, 1813. *Smith's Geological Map*, 1821.)

The character of the numerous cottagers upon the estates is also an object of great solicitude, and without any interference with the manner in which a man may choose to occupy himself, their regular and decent behaviour is made the subject of care and attention; and the steward has strict directions to watch carefully over them, and where possible to promote their improvement. Wherever a potato garden can with advantage be added to their cottage, that accommodation is afforded them. In the vicinity of Trentham the cottages are of the best sort, and with their gardens kept in the nicest order. To almost every one of them is attached land for the maintenance of one or two cows. It is a circumstance worthy of remark, that of all the labourers who possess a cow, none receive relief from the poor's rate, except one widow at Trentham, who has a large family, and even in this instance, the relief she receives is in a less ratio than any person labouring under similar difficulties. (*Loch in 1819.*)

11. Live Stock.

Cattle generally of the long-horned breed. The Staffordshire cow is generally considered a tolerable milker, as well as feeder.

Sheep. Three sorts considered native breeds: the grey-faced hornless, or Cannock heath sheep, with fine wool; the black-faced horned, with fine wool; and the white-faced hornless, with long wool.

Swine. A cross between the slouched-eared and dwarf breeds; require little attention or feeding, and easily get fat on the refuse of the dairy or barn. Pitt, the reporter, had a very fine sow, which littered ten at the first litter.

Rabbits. Wild in the sandy lands. A good many bees kept; Thorley's plan tried, but bees are found to succeed best in straw hives thatched in autumn. "Those which have not raised a sufficiency of food for winter, it is doubtless humanity to destroy, as sudden suffocation is better than a prolonged but certain starvation."

12. Political Economy.

Roads now generally good; numerous canals; several private rail-roads. Manufactures, iron, hardware, nails, glass, toys, japanned goods, potters' ware, cotton cloth, silk fabrics, leather, woollen, linen, and many others. Manufactures sometimes carried on in the country in straggling groups of houses, but for the most part in towns. Many thousands both of men and women employed in making nails. An agricultural society at Newcastle, and another at Litchfield.

Experimental Farming. "It would be a wholesome plan for the Board to commence farming upon their own ideas, particularly in counties where the modes of agriculture seem improper; for instance, Lancashire, Westmoreland, Cumberland, Northumberland, &c.; by which ocular demonstration their plan might be imitated; for hearing or reading of any particular practice will not do for farmers in general." Such is the reporter's opinion, in ours a most erroneous one.

7. Grass.

235,000 acres in meadows and pastures, and 60,000 in artificial herbage. Formerly dairying common, and Warwickshire cheeses produced in abundance; but now breeding is fast assuming its place. Old pastures overrun with ant-hills and rubbish. Murray very prophetically observes, that if peace were to take place, grass lands would be safer for the farmer than corn lands. Dairying and feeding both in practice.

8. Gardens and Orchards.

The gardens of the Marquis of Hertford, at Ragley, noted for their pine apples; few sale orchards of any extent.

9. Woods and Plantations.

Oak and elm every where abounds; the Leigh estate the best wooded, but every where abundance of timber.

10. Improvements.

Much draining done in the northern part of the county; but it is rather singular that the names of Fazley, Elkington, or their farms, are not once mentioned in Murray's report. Joseph Elkington lived at Princethorpe, in Stretton on Duns-moor, six miles S. W. of Coventry, and afterwards in Birmingham. He died in 1806. He was a mere empiric practitioner, and knew nothing of geology, the only foundation for draining on scientific principles; less even than some of his contemporaries, as Farey has ably shown in the Derbyshire report.

11. Live Stock.

No particular breed of cattle; but as feeding is the prevailing practice, farmers buy in whatever breed they think will pay them best.

Sheep a good deal attended to; the large-polled sheep, or ancient Warwickshire, now generally mixed with other breeds. The first cross of a Leicestershire ram and Warwickshire ewe produces the best sheep for the butcher.

Horses, the heavy black Leicestershire breed; a good many bred, of cart, coach, riding, and hunting horses.

Poultry abounds, owing to the prevalence of small farms; great quantities sent to Birmingham and London.

Game, as pheasants, partridges, and hares, more than commonly abundant.

12. Political Economy.

Roads tolerably good; several canals; innumerable manufactures, especially at Birmingham, for iron, and others of the metal kind, and Coventry for ribands.

13. Means of Improvement.

Leases; a more economical mode of labouring; draining; drilled root, and herbage crops, and better rotations.

1. Geographical State and Circumstances.

Climate mild and temperate; no mountains or bogs to produce a cold or moist atmosphere.

Soil; no stiff clay or sand, no chalk; the peat bogs which existed have been long since drained, and become meadow soil; clayey loam, sandy loam, and meadow, compose the soil of the county. Dishley farm, so well known, consists of a mild friable loam, of a good depth, on a clay or marl bottom.

Minerals; coal, lime, lead, iron, slate, and freestone; all worked. A mineral spring at Burton Lazars.

2. Property.

Estates generally large; that of the Duke of Rutland has been much improved, and always managed in the most liberal and benevolent manner.

3. Buildings.

Many very magnificent, as Belvoir Castle, Donnington Priory, &c. Farm-houses not built since the commencement of this century are of very inferior construction; timber and plaster covered with thatch. In general, the modern enclosed parishes have the worst farm-houses, they being almost always cooped up in the villages; in the more ancient inclosures, farm-houses have been erected in the midst of the occupations, and built with better materials. Dishley farm-house is of ancient construction, and has probably been built at different times, whence it wants regularity and compactness; it has, however, taken altogether, a style of pastoral simplicity, united with neatness, and exhibits a specimen of that judgment and taste which joins convenience with economy, so far as it can be attained without regular design; the out-buildings too seem to have been put up at separate times, as wanted; the yards and pavements are remarkable for neat cleanliness, and the whole farm business for being conducted with good order and system. The houses of other principal breeders are comfortable and substantial, and of course fitted up in a style suitable to the taste and situation in life of the occupier.

Cottages generally in villages, and formed of mud walls and thatch; a few good new ones of brick and native slate.

4. Occupation.

Farms of all sizes: a great many from 80 to 100 acres, on which the farmers work with their own hands; near market-towns, many under 100 acres, occupied by tradesmen and manufacturers; general size, 100 to 200 acres; and those of the principal breeders, from 200 to 500 acres. Land chiefly in pasture for sheep, the dairy feeding cattle, breeding horses, and hay for winter use: dairy farms have also sufficient arable land to produce straw and turnips for their own use; the most inferior soils in aration. The Duke of Rutland has 2000 acres in hand, including the park, woods, gardens, &c. At Donnington, Lord Moira had 370 acres, under a Northumbrian bailiff, besides the park of 450 acres. Dishley Farm, near Loughborough, in the occupation of the family of the Bakewells for three generations, and now of Robert Honeybourne, nephew to the last Robert Bakewell, who died a bachelor, contains between 400 and 500 acres.

Irrigation is judiciously practised, and the culture of the arable uplands has been long conducted on so correct a system that few weeds now come up; the most troublesome is chickweed. Heifers of three or four years old draw in the cart or plough; three of them form a team, and work nine hours a day. Farmers in general intelligent. Leases not universal.

5. Implements.

Plough with two wheels, and drawn by three, four, or five horses, or cattle in a line walking in the furrow. Thirty years ago, wheels were first applied to the fore end of the beam, and it was found that by pitching the ploughs a little deeper, and setting the wheels so as to prevent its drawing in too deep, the wheels were a sufficient guide, and the plough required no one to hold it, except in places of difficulty; one person attending was therefore sufficient to drive on the team, turn the plough in and out at the ends, or guide it in particular hard or soft places. Soon after another furrow was added, by slipping an additional beam to the off side of the former one, somewhat lengthened, with foot-share and shelboard; the same number of wheels, viz. one on each side, guiding the two furrows. Among the uncommon implements may be included, a rack and manger for four colts on wheels, to be drawn from one pasture to another. It is square in the plan, and therefore each colt has a side to itself, and cannot kick or bite at the others; a break for shoeing oxen; a fastening for ewes, to lessen the fatigue of the ram during copulation; and also several ploughs, rakes, &c. the invention of Hanford and Co. at Hathern, near Leicester.

6. Arable Land.

Many farms have none. Drilling corn crops principally introduced; but not for turnips, even at Dishley; thought to lose ground; cabbages and rape a good deal cultivated on the soils too strong for turnips.

7. Grass.

Excellent meadows on the rivers and rills; fertilised by inundations; upland pastures sometimes manured. Stilton cheese made in most villages about Melton Mowbray. On the Trent, considerable patches of reed, which pay as well as the best meadow land.

8. Gardens and Orchards.

Gardens much wanted to cottages; orchards rather neglected, though the soil is in many places well adapted for them.

9. Woods and Plantations.

Few, excepting about gentlemen's seats, and in the hedgerows. Willows, as pollards, grown on Dishley and other farms, to supply stuff for hurdles, rails, and gates.

10. Improvements.

Elkington was a good deal employed by the proprietors. Irrigation more extensively practised in this county than in most others.

11. Live Stock.

Cattle, the long-horned breed. What was the particular breed of cattle in Leicestershire before the middle of the last century, about which time Bakewell began his exertions, it is difficult to determine; perhaps there was not any distinct breed, with particular specific characters, whereby they might be distinguished; although there were always great numbers bred, yet the produce was never equal to the supply of the

county: there always was, and still is, an influx from Ireland, Wales, Scotland, Shropshire, Staffordshire, Herefordshire, Northumberland, and Lancashire; the latter of which were most probably the stock from which Bakewell began his breed: His first best cows, it is believed, were artfully obtained from Webster of Canley, in Warwickshire; and his famous bull, Twopenny, was bred from one of these cows, or from one procured from Phillips of Garrington, and a bull from Northumberland. From these beginnings, with great judgment and attention, in a short time he reared some beautiful cattle; they were long and fine in the horn, had small heads, clean throats, straight backs, wide quarters, and were light in their bellies and offals; they were gentle and quiet in their tempers; they grew fat with a small proportion of food, but gave less milk than some other breeds. Some years ago, Bakewell put three new-milched cows in three separate stalls, a Holderness, a Scotch, and one of his own breed; the Holderness ate most food, and gave much the greatest quantity of milk; the Scotch ate less food, and gave less milk, but produced most butter; his own cow ate least food, gave the least milk, and made the least butter, but laid on the most flesh: hence it will follow that the Dishley cattle are most adapted for the grazier, and the produce of beef. No man, perhaps, ever made more comparisons between the different breeds of cattle than Bakewell, and no one that was able to tell so much has told us so little about them. Many capital herds of cattle in the county, and a number of dairies, from which great quantities of cheese is sent to market.

Sheep. The present stock consists of three varieties, the old and new Leicester, and the forest sheep. The old breed, which is spread over Northamptonshire, Warwick, and Lincolnshire, are an improvement on the ancient stock of the common fields. The new breed Bakewell produced by breeding from selected sheep from his neighbours' flocks, or those of the Gibbers. A ram society was formed by Bakewell and others, and still exists, the object of which was a monopoly of ram-letting. The late Bakewell bound himself, and his successor, Honeybourne, binds himself, not to engage nor show his rams to any person till the members of the society have seen them and are supplied, and not to let a ram to any person within fifty miles of Leicester, for a less sum than fifty guineas, for which, and other privileges, the society pay a large annual sum; and Honeybourne, and the other members of the society, confine themselves not to sell, nor to let, their ewes at any price, nor to show their rams at any public fair, nor at any other place than their own houses, and that only at stated times, from the 8th of June to the 8th of July, and again from the 8th of September till the end of the season; with several other regulations of a similar tendency.

Ram-letting alone has produced to Bakewell 3000*l.* in one year. The greatest prices were paid about 1789; since that time they have declined; still, about 1807, from sixty to one hundred guineas have been given for the use of a ram for one season. Much curious information on this subject will be found in the report.

Folding is not practised.

Fattening is practised as usual with grass, and in winter and spring with artificial food. Bakewell frequently fattened sheep in stalls; in three days they were reconciled to their confinement, and began to feed. "Further than this," the reporter's informant, Bakewell's successor, "knows not, or is not inclined to communicate."

The forest sheep are confined to Charrwood; they are grey-faced, and partially horned, but now almost extinct.

Horses have been bred in Leicestershire from time immemorial, and the breed considered superior. Bakewell went through Holland and Flanders and purchased some Friesland mares, which excelled in those points wherein he thought his own horses defective, from which, with great labour, expense, and judgment, he produced some capital horses, and in particular, his famous horse Gee, the noblest, and most complete and beautiful, creature of the kind that had been seen in Europe. How far his elegant points were adapted for the labour that horses of this sort are principally designed to perform, is a question, perhaps, undetermined; be this as it may, beyond all controversy he was strong and handsome, and commanded the admiration of all who saw him; for a time he was the first subject of conversation, and almost the wonder of the day; he was taken to Tattersall's, and shown there to the nobility and gentry, with great approbation; and Bakewell had the honour of showing him personally to Geo. III.; he is said to have been very quiet and docile, and Bakewell, in describing his points, invited his majesty to touch him, which was declined. He was killed by lightning, in his pasture. The present horse-system at Dishley is this:—Three or four very capital black stallions are constantly kept; these are occasionally worked, and are always rendered docile enough for that purpose, if wanted; those kept at home cover at two guineas the mare, and those let out never at less than one guinea. Eight or ten brood mares, of the same stout black breed, are also kept, but no geldings; these do all the farming work of between 400 and 500 acres, with occasional assistance from the stallions, as well as from bullocks and heifers; of the mares, all that are fit are put to the horse, of which three are reckoned upon the average to rear two foals, allowing one in three for casualties.

Asses used in many parts of the county for carrying burdens, and lately introduced as farmer's stock; especially for clearing green crops from clayey soils, in wet weather, their step being light. The turnip panniers open at bottom, to let out the load. Lord Moira had Spanish stallion asses, fourteen hands high, which he let out to cover at two guineas a mare.

Mules have long been in use for the saddle, road-work, and the plough.

Hogs greatly improved by various breeds. Honeybourne's seem to have a cross of the wild boar. Astley's is between the Chinese and Berkshire. At Donnington is a German boar, the bacon from whose progeny is of extraordinary sweetness and good flavour.

Bees attended to, but not so much as they deserve.

12. Political Economy.

The roads in the north-west of the county, in the neighbourhood of Loughborough and Ashby, are many of them laid out upon the concave system.

Bakewell and others were advocates for this system; but it does not appear that they are considered to be attended with

any advantages by those who live beside them, and constantly use them. Various railways and canals. Manufactures, wool-combing, woollen yarn, worsted, and especially worsted stock-

ings; also cotton-works, hats, patent net-lace for veils, &c. The Leicestershire and Rutlandshire agricultural society established 1794.

7799. **DERBYSHIRE.** A mountainous and hilly surface of 622,080 acres of great variety of soils, but more remarkable for its mining and manufacturing productions than its agriculture. It is, however, at the same time both a corn and pasture county, and noted for its cheese; it is every where full of ingenuity and interest; and the Report by Farey, in three volumes, is one of the most interesting and valuable of the county reports: it is an example of extraordinary industry, research, and excellent general views, and will be read with great profit by every class of readers. Farey, indeed, was a philosopher ahead of the age in which he lived. (*Brown's Derbyshire*, 1794. *Farey's Agricultural and Mineral Survey*, 3 vols. 1811 to 1815. *Marshal's Rev.* 1812.)

1. Geographical State and Circumstances.

Climate. Cold on the hills, but mild in the plains; in the vales hoar frosts often injurious; no prevailing winds; rain about twenty-eight inches per annum.

Soil very various, chiefly calcareous.

Minerals. Lead and iron those chiefly worked; also some zinc, calamine, black jack, manganese, sulphur, &c.; coal, lime, alabaster, slate, freestone, paving stone, rolling, grinding, scythe, and cutlers' stones, and a variety of others, both for use and ornament, as spar, &c. Clay in some districts, as at Overmoor, is burned by spadefuls, dried, and mixed with small coals in heaps, for the roads. E. M. Munday, Esq. of Shipley, formed his private roads of a sort of bricks, made without the corners to avoid the duty.

Water. When scarce, drinking ponds made by puddling and paving in the Gloucestershire manner. An artificial pond discovered in 1808, concealed under peat, the head of which was puddled in the centre: a proof that puddling is no new art. Stone cisterns, placed in the lines of neatly cut thorn hedges, serve to supply two fields: the water brought to them in thin zinc pipes, as being cheaper, and perhaps more durable than lead.

2. Estates.

Of various sizes as in other counties; managed by attorneys, at a low salary, who make it up by law business, and otherwise.

3. Buildings.

Chatsworth, Keddlestone, and some other noble stone mansions in this county; some good houses, covered with cement (known in London as Atkinson's), made from clay stones found on Lord Mulgrave's estates in Yorkshire, and which Farey considers as superior to that made from the clay balls of the London clay stratum. Grottos frequent, fitted up with the spar of the county. At Ashover a frieze of a chimney-piece, representing a section of the strata taken across the parish. At Chatsworth, and various places, the spits in the kitchens turned by water-wheels, of the overshot kind, supplied by small lead pipes. Hair lines, in covered boxes, placed on drying parts, and the lines wound and unwound by a handle, for drying clothes. At several houses foot lath-wheels, turning spindles, on which were other wheels, dressed with emery for cleaning knives; also brush spindles for boots and shoes, as at the Angel Inn, Oxford; boot-rack, in which boots are reversed on upright pins and taken off by a stick, which prevents dust settling inside the boot.

Farm-houses as in other counties; a few good ones recently erected. One of the most complete farmeries is that of the Earl of Chesterfield, at Bretby Park; it is of hewn stone, slated, and combines a general farm-yard, dairy court, and two poultry courts, including pheasantries. Buildings in general roofed with grey stone or other slate; water, in some cases, conducted down from gutters by a light wooden rod, down which the water runs as well as if it were in a spout or tube, and not blown about by the winds, as it would if no rod were there. Fire-proof floors made by arching them with hollow bricks; in the cottages, cast-iron ovens by the sides of the fires very common, and also iron cisterns for hot water; both these were originally brought into notice by the Griffin foundry, about 1778.

Cottages better than in most other counties; some good ones erected by the principal manufacturers and noblemen. Virgin's bower, or other beautiful flowering creepers, and shrubs, and plants, are not uncommon at the cottage doors in this county, among other indications of their attention to neatness and of their comforts, compared with the inhabitants of the miserable huts in many other districts.

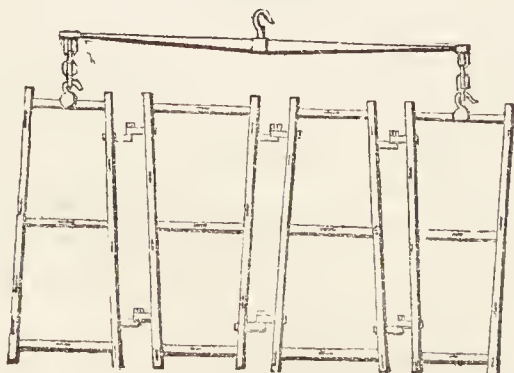
4. Occupation.

Farms generally of small size; farmers rank higher in intelligence than those of most southern counties; nothing but leases and larger occupations wanting to render this one of the most improved counties of England. Best farmers also at same time manufacturers or miners.

5. Implements.

Swing ploughs and pair; one-horse carts; good harrows (*fig. 1003.*); weeding scissars, for clipping off weeds among corn

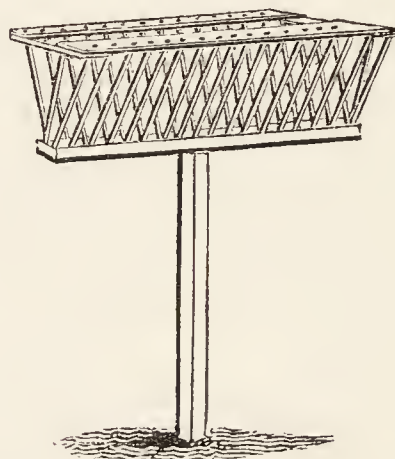
1003



close, or rather under ground; weeding pincers; threshing-machines; cast-iron rick stands; cattle cribs mounted on posts, which turn round on a pin, so that when the cattle have well trodden the litter on the two opposite sides, in standing to

eat from the crib, it is turned half round for them to tread and dung, &c. in the opposite direction. (*fig. 1004.*) Turnip-slicers, chaff-cutters, bruisers, slate cisterns as milk vessels, &c.

1004



6. Enclosures.

In setting out fences, less attention paid to separating the different kinds of soils than is requisite; walls frequent; and holes often made in them for passing sheep; to be closed when not wanted by a flat stone; slacked lime plastered on the face of a newly planted hedge (as clay is in Norfolk), to prevent the weeds from rising. Young thorn hedges, with a northern aspect, do best, as the morning sun in spring injures the bud of those facing the south when previously covered with frost. Roots of thorns, sometimes planted as sets with success; old thorn-hedges effectually renewed by cutting off the shoots below the surface of the ground; the roots then throw up vigorous shoots. Neatly clipped hedges at Ashbourne. Magnesian, limestone, and marly soils found to suit the holly better than any other.

7. Arable Land.

Only one fifth of the county in aration; formerly six horses were generally employed in ploughing, now only two; turnips drilled in the Northumberland manner in various places; some wheat dibbled; oats a good deal cultivated, and oat-cakes or Haver (*Ger.*) cake made, by pouring sour dough on a hot stone: a sprinkling of parsley sown with clover to prevent cattle hoving; sides of oat ricks tucked in with a spade, to leave no loose straws for sparrows to rest on.

Chamomile "is cultivated to a very considerable extent on the limestone and coal strata near Ashover;" the flowers are picked by children, dried first in the shade and then on a malt-kiln, afterwards packed tight into bags, and sent to the London druggists; the crop stands three years, and then gets weedy and declines."

Wood cultivated on a small scale.

Widow-nort (*Genista tinctoria*) infests old pastures, and is pulled when in flower, and dried and sold to the dyers.

Yarrow (*Achillea Millefolium*) is in some places also taken up, tied in bunches, and dried for the dyers.

Valerian (*Valeriana officinalis*) is grown at Ashover, and also elecampane (*Inula Helénium*), lavender, peppermint, and rhubarb, on a small scale, in one or two places.

Truffles (*Tuber cibarium*) collected in various places, especially under the shade of the beech trees, and on dry hedge banks. Roses formerly cultivated for the flowers, but not at present.

8. Grass.

Three fifths of the county under permanent grasses (though it appears by the marks of ridges to have been formerly every where arable), and the application chiefly cheese-making. Droppings of cattle and horses on pastures spread by rakes, which injure the grass less than any other implement. Fern and other weeds collected from wastes, and dried and burned, and their ashes made into balls, and laid aside, to be used as ley for washing. This practice declines with the frequency of enclosures. When worms are engaged forming worm-casts in fields, scatter barley chaff, fresh and dry from the winnowing machine, which, sticking to the worms when they come out, prick them, and prevent their return to their holes, till rooks, &c. devour them.

9. Gardens and Orchards.

Good market-gardens at all the principal towns, and few of the farm-houses and cottages without gardens. "Samuel Oldknow, Esq. of Mellor keeps a professed gardener, on three acres of rich sheltered land, by the river Goyte, on the Cheshire side of it, who cultivates, gathers, prepares, and delivers all the useful vegetables and common garden fruits in season to his cotton mill work-people and tenants, and renders an account once a fortnight to the mill-agent, who deducts what they have purchased from the garden from their several wages; the perfection and utility of his arrangement for these purposes cannot but prove highly gratifying to those who wish to see the labouring classes well and comfortably provided for from the fruits of their industry. Proper rooms, for drying, cleaning, and preserving garden-seeds and fruits, and his wool-chamber and other like offices, are attached to the gardener's house, and

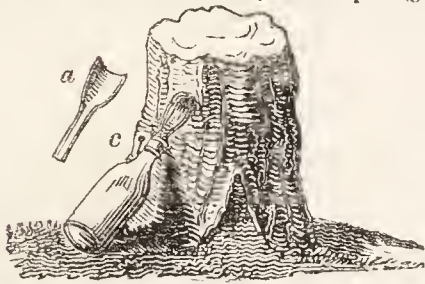
placed under his care." A most productive garden at Belper, on a very poor soil, but irrigated in winter from a cesspool, in which centres the liquid manure of fifty cottages, belonging to Messrs. Strutt's cotton mills.

Orchards seldom planted, though the soil is well adapted for them in many places.

10. Woods and Plantations

A good many coppices, the produce of which is much in demand both for mining and agricultural purposes. Sir Joseph Banks, at Ashover, has planted some exposed sites in a new manner: first planting narrow slips of Scotch fir at the distance of 100 yards, then intersecting them by others, so as to leave the surface checkered; after the Scotch firs are grown a few years, it is the intention to fill the intervening patches with arches, at such a distance as that they will never require any thinning. This plan, as Farey justly hints, is more ingenious or fanciful than likely to be useful; the mixture of the larch and Scotch firs, with a proper attention to thinning, would be a more effectual, speedy, and economical mode of producing timber. Some judicious observations on pruning trees, and the propriety of Pontey's mode, pointed out by various examples. Hedge row trees, sparingly introduced and well trained, are nearly all that fertile agricultural land ought to contribute to the national stock of timber. Key-bearing ash trees, or any forest tree much given to bearing seeds, no longer increases much in timber, and therefore ought to be cut down; hence male ashes preferable to females, or such as have both male and female flowers on the same tree. The use of the spray and buds of the oak as bark recommended, as practised in Cheshire and South Wales; when collected, they should be immediately sent to a mill and crushed. A most complete seasoning kiln for timber at Belper. Timber often sold by ticket sale, — thus described: the vender meets the proposed purchasers, writes his price in an envelope, and puts it in a glass; the offerers do the same; the vender opens the envelopes, and if any price comes up to his, then he accepts it, if not, the process is three times repeated, and then the vender must show his price, if none has come up, but not if any one has gone beyond it. In felling trees with an axe, cut *dishing*, if young shoots are expected to succeed, as the sooner the centre rots the better the wavers thrive. Larch trees bear neglect better than any others, as they never produce timber boughs.

Birch wine has been made from an open grove of about 100 birch trees, near Overton Hall, for sixty or seventy years past. Thirty trees or more are tapped in a season, about six or eight inches above the ground, in March. A piece of bark, about three quarters of an inch in diameter, is cut out with a gouge, and the wood penetrated an inch or more; an iron spout (fig. 1005.a).



is then driven into the bark below the hole, which conducts the sap bottle (c). In warm weather the holes soon grow up, and will cease to run in four or five days; but in windy weather they will run for a month. Some trees will run twenty-four gallons in twenty-four hours, others not half a pint. The water is sold at sixpence a gallon, to those who make small wine as a substitute for small beer. If the water is scalded (not boiled), it may be kept a month before it is made into wine; if not, it will not keep above a day or two. For making the wine, two pounds of coarse sugar, and a quarter of a pound of Malaga raisins, are added to every gallon of birch water, when cold: it is then boiled about an hour, until it is observed to grow clearer, when it is set to cool; and when about at the same heat that beer is set to work, a toast of bread, spread with yeast, is put into it, and for four days suffered to work freely, when it is barrelled, and the same quantity of raisins as before, and about an ounce of isinglass to every twenty gallons is added. It seldom works out of the barrel, and in two or three weeks is ready for close bunging down, to remain for three months, when it should be bottled off, and in two or three weeks after it is fit for drinking, but is the better for keeping longer.

11. Improvement.

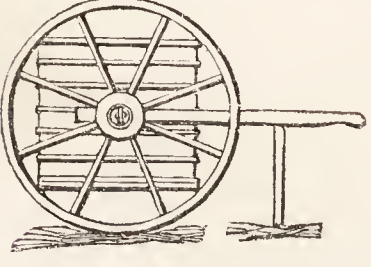
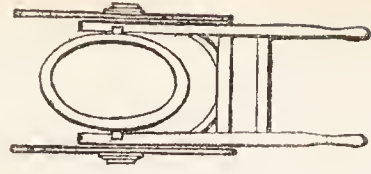
Magnesian or hot lime very thinly spread has its inimical properties; and it would seem such limes may be used where a stimulant rather than an addition of calcareous earth is required. Lime over-burned melts and runs together, will not slack, and becomes useless; the consequence of too strong a fire being applied to magnesian limes more especially. Might not the dried mud of limestone roads be used instead of lime? Many bone mills in use: they are composed of ratchet-like iron wheels and rollers, between which the back-bones of horses, with their adhering ribs, pass with facility, and are crushed into small pieces; the bones collected in London, from the churchyards and other sources; seven quarters dress an acre. Coal ashes almost entirely neglected, though a valuable manure. Importance in draining of bearing in mind the difference between surface and spring draining, and bog and upland draining.

12. Live Stock.

Cow stock for the dairy the prevalent stock in Derbyshire; no particular breed; noticed nine breeds and nine crosses of these. Many consider that rather poor land makes the best cheese, and old sward more and better than artificial grasses. In some cases some slacked and powdered lime strewed on the willow trees within the reach of cows, to prevent their eating them, and tasting the butter. Milk set to raise its cream in yellow dishes, with lips; in some places in slate troughs; carried home in suspended tubs. (fig. 1006.)

Sheep. Ten different breeds, and seven crosses of these and others; wool chambers generally form a part of the accommodations of the farmeries.

Horses. Those of Derbyshire ranked next to those of Leicestershire, for being stout, bony, and clean-legged.



Asses in considerable number used by the smaller manufacturers, and in the coal-works, potteries, &c.; also on the iron railways.

Swine. The Earl of Chesterfield supplies his table with delicious sucking pigs, of a fortnight old, from his Otahette sow; plan of shaving off the gristly or horny projection of the snout, to prevent digging, recommended. Tethering by the neck also suggested for eating down sturdy herbage crops. A pin and screw to be used like those for fixing down Salmon's harmless man-trap. (Trans. Soc. Arts, vol. xxvii. p. 183.)

Poultry. The Earl of Chesterfield's poultry yards at Bretby, perhaps as complete as any in the kingdom. The roosting-house is well contrived, with covered places for the ducks and geese under the fowls, and the whole is constantly kept strewed with fresh saw-dust. The sitting-house, and which serves also for laying, is furnished with flues, to preserve an equal temperature in frosts. In the feeding-houses, the fronts, partitions, and floors of the pens, are all of lattice-work, which readily take out in order to wash them thoroughly; shallow drawers with fresh sawdust pass under each pen to catch the dung. The fattening poultry are fed twice a day, and after each the food is taken away, and the daylight excluded, for them to rest and sleep.

A breed of brown American turkeys at Brailsford; they roost upon trees or the high parts of buildings; cocks weigh twenty pounds when fat, but the hens much smaller.

Geese when let out have a stick about two feet long slung before the breasts of the old ones, which is found to prevent them creeping through hedges, &c.; feed on *Festuca fluviatilis*, &c. When waters are much impregnated with lime, the eggs of geese and ducks that frequent them are so much thickened that hatching becomes difficult.

Hens. At Plesby a fine breed of black fowls; round Wingerworth many game fowls kept for cocking. In Tansley the cockpit converted into a methodist meeting-house. Eggs preserved hung in nets, and turned into a fresh position each day; this being the main essential in preserving eggs, whose yolks subside slowly when left unmoved, and come at length to touch the shells on the lower side, when rottenness almost immediately commences.

Bees kept in various places.

Fish. Certain ponds in Sir Thomas Windsor Hunlocke's Park, in Wingerworth, are appropriated to the feeding of castrated male carp and tench, which are found very superior in size and flavour to other fish; the late Sir Windsor Hunlocke saw this practised in Italy, many years ago, and had one of his servants, who was with him, instructed in performing the operation; which is less difficult or dangerous than might be supposed, and in consequence of which, not more than one in fourteen or fifteen of the fish die.

Angling permitted at Combs-brook reservoir of forty-five acres, the angler paying sixpence per pound for the fish taken. Salmon pass and trap on the Derwent, at Belper bridge.

31. Rural Economy.

Rewards are offered by the Agricultural Society at Derby, as by most others in the kingdom, for long and meritorious hired or day service, but seldom for having performed the greatest quantities of job-work, or earned the most money by such at fair prices. At the beginning of the present century, it was calculated, taking the labourer's wages at two shillings and sixpence per day, that he must work four and a half times as many days to earn the same quantity of food, as from three to five centuries back he could, when his daily wages was from fourpence to twopence per day! Part of this was doubtless occasioned by the many idle saints' days which the church of Rome imposed on the people at the earlier periods.

14. Political Economy.

Various concave roads formerly, made through the influence of Joseph Wilks, Esq. of Measham; these in a very indifferant state, and illustrate the absurdity of the principles on which they are constructed. To level across a road a string level used. It consisted of a piece of boxwood eleven inches long, one and a half broad, and one and a quarter deep, into the top of which a spirit-level tube was deeply sunk, and to the top, at each end of this level, several yards of strong whipcord was fastened. In using this instrument, a labourer was placed on each side of the road, having the cord in his hand, which they pulled very tightly, and steadily against each other, and thereby made the bubble assume the middle of the tube or either end, according as the two ends of the string were held level or one higher than the other.

Some remains of wavy roads (3551.), but nothing to justify any deviation from the general form of slightly convex roads, with straight or even surfaces as to length. The road between Ripley and Little Eaton, where washing or irrigation has been adopted as a mode of clearing (Com. B. Ag. vol. i.) was "miserably deep, loose, and bad."

In Manufactures Derbyshire ranks next to Lancashire, Staffordshire, and Warwickshire.

- 1. Trades, &c. depending on the Animal Products of the county.
 - Blanket-weaving, and scouring.
 - Bone-crushing mills.

Butter.
 Button-moulds, of horn and bone.
 Candle making, of tallow.
 Carpet-weaving.
 Cheese.
 Curriers or leather-dressers.
 Fellmongers.
 Fulling mills.
 Glue-makers.
 Leather mills, for oiled and chamois leather.
 Meat, beef, lamb, mutton, pork, veal.
 Shoe factory.
 Skinners, or leather-dressers, chamois, &c.
 Soap-makers.
 Stockings, of worsted.
 Tanyards.
 Woollen-cloth factories, yarn spinning, weaving, and cloth dressing.
 Worsted spinning, for the hosiers, by hand and jennies.

2. *Trades, &c. depending on Animal Substances, imported.*
 Hat-making and unsplit straw hats.
 Silk-spinning mills.
 Silk-stockings weaving.

3. *Trades, &c. depending on Vegetable Productions of the county.*
 Basket and wicket making.
 Besom or broom do.
 Boat or barge building, for the canals
 Breweries.
 Chamomile flowers.
 Charcoal burning and grinding.
 Charcoal mills, for grinding it.
 Corn, barley, beans, oats, peas, wheat.
 Hoops for casks, of wood.
 Malt-makers.
 Mattresses, chair-bottoms, &c. of straw.
 Millers, flour or meal makers.
 Sieves, or riddles for corn.
 Shelling, or oat-meal mills.
 Timber.
 Turning mills, for wood, bobbins, bowls, cheese-vats, dishes, tool-handles.

4. *Trades, &c. depending on Vegetable Substances, imported.*
 Bleaching-houses, and grounds.
 Calico-printing.
 Calico-weaving.
 Cambric-weaving.
 Candle-wick, bump or bomp spinning-mills
 Cotton-spinning mills.
 Dye-houses.
 Flax-spinning mills, linen-yarn mills.
 Fustian-weaving, thicksets.
 Hop-bag spinning and weaving, wool-bags, &c.
 Lace-weaving, or warp frame-lace making.
 Lace-working, or needle-working of frame-lace.
 Linen-weaving, sheeting, checks, &c.
 Muslin-weaving.
 Nightcaps, of cotton frame knitting.
 Packthread spinning, string, twine.
 Paper-making.
 Rope-making, cords, halters.
 Sacking weaving, corn-bags.
 Sail-cloth weaving.
 Stocking-weaving; principally of cotton, some of worsted frame-knit.
 Tape-weaving mills.
 Thread-spinning.
 Whipcord-spinning.

5. *Trades, &c. depending on Mineral Products of the county.*
 Bakestone making.
 Boiler-making, of wrought iron, for steam-engines.
 Brick-making, building, draining, fire, paving.
 Building-stone, or free-stone, ashler, capping, eaves-slates, gable-stones, paving, ridging, grey slates, or tilestones and stack-posts.
 Cannon-balls, or shot and shells.
 Cannon-casting and boring.
 Chain-making, iron and cast-iron.
 China-stone, or white potter's chest-pits.
 Cisterns and troughs of stone, to hold water.
 Clay-pits, brick, china, fire, pipe, pottery, and tile.
 Coal-pits.
 Coke-burning.
 Copperas-stone, brasses or pyrites pits.
 Fryingpans of iron.
 Grind-mills, blade-mills, grindstone mills.
 Grindstones.
 Gypsum, alabaster, plaster.
 Hammer mills, forge, tilt, planishing mills.
 Hoops for casks, of iron.
 Iron forges and furnaces.
 Ironstone pits, argillaceous ore.
 Lead-mines, or veins of lead ore.
 Lead-smelting cupolas, and slag-mills.
 Lime-kilns.
 Limestone quarries.
 Malt-kiln plates, of perforated cast-iron.
 Marble quarries.
 Marble sawing and polishing mills.
 Marl pits, for manuring.
 Mill-stone quarries.
 Nail-making, of cast-iron.
 ——— clasp (or carpenter's), and spikes, &c.
 ——— horse-shoe.
 ——— shoe-makers.
 Ore dressing washing, buddling.
 Patten rings, or clog irons.
 Pipe-making, tobacco pipes.
 Pipes, of earthenware, hollow bricks, for conveying water.
 — of lead, drawn.
 — of zinc.
 Plaster of Paris works, gypsum.
 Potteries, earthenware, stoneware.
 Pot-stones, pye or lump stones for the iron forges.
 Puncheons, stauncheons or props, for the coal pits.
 Red-lead works, minium.
 Rivets, of iron, softened, for coopers, boiler-making.

Rolling and slitting mills, for iron bars, plate iron, nail rods.
 Rotten-stone, or polishing earth.
 Sand-pits, casting or founders', house-floor, mason's mortar, scouring, and scythe-stick sand.
 Saw mills, for stone and wood, also with circular saws.
 Screws, carpenters', for wood.
 Scythe-sticks and stones for sharpening scythes, hay-knives.
 Sheet-lead, milled lead, rolled lead. Common sheet-lead is cast by most of the plumbers and glaziers of the county.
 Shot, leaden.
 Slitting mills.
 Spar-workers, petrification workers, gypsum, calcspar, fluor.
 Sulphur-works, annexed to the principal smelting houses.
 Tenter hooks, of cast-iron, softened.
 Tile-kilns, draining, gutter, hip, pan, plane and ridge.
 Tire for carriage wheels.
 Whetstones, rubbers, hones.
 White-lead works.
 Wire-drawing, steel.
 Wire-working, safes, sieves, screens.
 Zinc mines, blend and calamine.
 — work, malleable plates, wire pipes, &c.

6. *Trades, &c. depending principally on Mineral Substances, imported.*

Axes, hatchets, bills, adzes.
 Brass foundry.
 Bridle-bits and buckles.
 China factories.
 Chisels, gouges, plane-irons, and other edge tools.
 Clock and watch making.
 Colour-grinding mills, paint.
 Cotton machinery makers, for the cotton-spinning mills.
 Cutlery, knives, forks, &c.
 File-making, rasps.
 Flint-grinding mills, for pottery glazing.
 Frame-smiths, stocking-loom makers.
 Glass-making.
 Gunpowder-making.
 Hoes (garden, turnip), paring shovels, trowels, &c.
 Implement makers, agricultural tools.
 Malt mills, steel mills.
 Mangles, for linen clothes.
 Mechanists, machine, tool and engine makers.
 Millwrights.
 Needle-making.
 Reaping-hooks, smooth-edged.
 Scissors, of cast-iron, cemented to steel.
 Scythe-smiths.
 Sickles, toothed reaping tools.
 Snuffers.
 Soda water makers.
 Spades, shovels.
 Spurs, of steel.
 Stirrup-irons of cast-iron, cemented.
 Tin-plate workers, tin-men.
 Washing machines for clothes.
 Worsted machinery maker, for the worsted spinning-mills.

Notwithstanding that many of the manufactures and productions above mentioned are separately of small importance and may contribute little or nothing towards an export trade from the county, yet, taken in the aggregate, they must be admitted to present a most flattering picture of the varied and great manufacturing industry of the county; showing it to contribute far beyond most other counties towards the supply of all its own wants, and contributing at the same time, in no small degree, towards the supply and general trade of the kingdom at large.

Education,

Among the labouring classes, the reporter observes, is better attended to than in most of the adjoining counties. He approves of the great attention paid to bringing up children in habits of frugality and industry; and contemplates, as "the great and desirable end, their complete emancipation from the moral slavery of poor-law dependence, and its attendant vices and misery." There are some persons, no doubt, who may not approve of all that Mr. Farey has advanced on this subject; for where is the writer that can please every reader? but there are none, we hope, who would not be gratified with his sincere and ardent desire for the more general and universal happiness of the British poor. Though we are of opinion that very little amelioration of that division of society which constitutes the agricultural or labouring class can be effected without an alteration in the laws; yet we are equally convinced, that no great alteration of what are called the poor laws would be advisable, till the poor are prepared for it, by having imbibed such a degree of knowledge as would enable them to meet the consequences with advantage, or at least without an increase of misery.

We agree with the reporter, that the case is somewhat different with the operative manufacturers, and mechanics congregated together in towns; for the wages of their labour depends, in most cases, as the wages of all labour ought to do, on the demand and the supply; whereas the weekly wages of the agricultural labourer depends but too often on the decision of the parochial vestry. The consequences of this state of things are ruinous to the rustic labourer, and call loudly for legislative interference and general sympathy. The extraordinary exertions at present making by the different classes of mechanics, to enlighten and ameliorate themselves, cannot fail in a short time to awaken the dormant powers of the country labourer.

15. Means of Improvement.

There are reading societies in most of the principal towns: to be regretted that the funds of the board of agriculture do not permit it to circulate cheap agricultural books; agricultural books have as large a sale in Derbyshire as in most other counties; some take the "Farmer's Magazine," and a great number the "Farmer's Journal;" which, if the stamp duty were taken off, would greatly increase in circulation, and be an incalculable source of improvement. An agricultural society at Derby, since 1794; a society for fat wether sheep at Repton: at Hayfield, a society of mountain sheep keepers, since 1790. A list given by Farey of ninety-three agricultural societies in England and Wales. The late Earl of Chesterfield's premiums annually to his tenants, as recorded in the Farmer's Journal, 27th December 1813, and 15th January 1816.

7800. NOTTINGHAMSHIRE. 495,000 acres of uneven or hilly surface, in great part a sandy soil, and more a corn than a pasture county. It contains the Forest of Sherwood, the only one belonging to the Crown north of the Trent. This forest was once celebrated as being the scene of the adventures of the famous Robin Hood. Very little wood, however, now remains. The report is one of the most defective and least interesting which the board have published, and is, besides, above a fourth of a century old. (*Low's Report*, 1798. *Marshal's Review*, 1812. *Smith's Geological Map*, 1821. *Edin. Gaz.* 1827.)

1. Geographical State and Circumstances.

Climate, remarkably dry.

Soil, chiefly sandy, great part clayey, and the remainder a lime and coal district.

Minerals. Stone, lime, coal, gypsum, and marl.

2. Property.

Estates from 12,000*l.* a year, downwards.

3. Buildings.

Few countries contain more gentlemen's seats in proportion to its size. Alston Grove, a noble residence; the gardens formerly in the ancient style, but lately modernised. Clumber Park contains four thousand acres. Newstead Abbey, celebrated as having been the residence of the Byron family; but now sold and divided. Thoresby park, thirteen miles round. Welbeck Abbey, the scene of the horticultural improvements of Mr. Speechly. Woolston Hall, a singular mansion of the date of Queen Elizabeth, by Thorpe, the same architect who built Holland House, near London. Farm-houses "not very spacious," of brick and tile, sometimes

thatched; now and then of stud and mud. Good farmeries, and central on the new enclosures.

4. Occupation.

Few farms exceed 500*l.* per annum: generally from 100*l.* to 20*l.* Few leases.

5. Implements.

Rotheram plough general; waggons have wide frames moveable for harvest use.

6. Various.

Enclosing going on rapidly; in arable culture, rotations good, but no remarkable practice mentioned; various hop-grounds and orchards, many woods and plantations; extensive woods raised from seed on the Welbeck and Clumber estates; the ground is first cleared of surface incumbrances, then cropped with corn two years, and turnips one year; the fourth year acorns, at the rate of four or six bushels, ash keys four, hawthorn berries one, and Spanish chestnuts one bushel, are sown broadcast on an acre, and ploughed in. The stocking and lace trade, cotton and silk manufacture, pottery, and various others carried on at Nottingham and other towns.

7801. LINCOLNSHIRE. 1,848,320 acres of uplands, vale and water formed lands. The soil in most places rich, and chiefly devoted to grazing; yielding on an average more beef and mutton per acre than any county in the island. Examples of embanking, draining, and warping, are numerous along the sea-coast and the Humber. (*Stone's Report*, 1799. *Arthur Young's*, 1794. *Marshal's Review*, 1812.)

1. Geographical State and Circumstances.

Climate, formerly unhealthy in the low parts, now the ague much less frequent. N.E. winds prevail in spring; much of the rain in summer from the northern and eastern quarters.

Surface, a great extent of low land, once marsh, and fen along the coast, now rich land in consequence of the embankments and drainage, which have been going on for nearly two centuries. Adjoining the lowlands are the wolds or calcareous hills, and the mainland part of the country is in general flat and uninteresting. Some parts of the county, however, as about Dalby, Spilsby, Stainton, &c. are varied and wooded, and command fine views of the low country.

Soil. There are large districts of clay, sand, loam, chalk, peat, and considerable extent of mixed soils.

2. Property.

Very much divided in the isle of Axholm; inhabitants collected in hamlets and villages, and almost every one is proprietor and farmer of from one to forty acres, as in France; and, as in that country, every farm cultivated by the hands of the family, and the family poor as to money, but happy as to their mode of existence. "The poorer farmers and other families work like negroes, and do not live half so well as the inhabitants of a poor-house; but all is made amends by possessing land." Lord Carrington, Sir John Sheffield, and — Goulton, Esq. great proprietors in the county; largest estate 25,000*l.* a year, others of 14, 11, 10, 8, 7, &c. and six of 2000*l.* a year. Lacey, a pretty village, "where each man lives on his own."

In the management of a great estate, "I remarked a circumstance at Reevesby, the use of which I experienced in a multitude of instances. The liberality of Sir Joseph Banks opened every document for my inspection; and admiring the singular facility with which he laid his hand on papers, whatever the subject might be, I could not but remark the method that proved of such sovereign efficacy to prevent confusion. His office, of two rooms, is contained in the space of thirty feet by sixteen; there is a brick partition between, with an iron plated door, so that the room in which a fire is always burning might be burnt down without affecting the inner one; where he has 156 drawers of the size of an ordinary conveyance, the inside being thirteen inches wide, by ten broad, and five and a half deep, all numbered. There is a catalogue of names and subjects, and a list of every paper in every drawer; so that whether the enquiry concerned a man, or a drainage, or an enclosure, or a farm, or a wood, the request was scarcely named before a mass of information was in a moment before me. Fixed tables are before the windows (to the south), on which are spread maps, plans, &c. commodiously, and those labelled are arranged against the wall. The first room contains desks, tables, and book-case, with measures, levels, &c. and a wooden case, which when open forms a book-case, and joining in the centre by hinges, when closed, forms a package ready for the carrier's waggon, containing forty folio paper-cases in the form of books; a repository of such papers as are wanted equally in town and country. Such an apartment, and such an apparatus, must be of incomparable use in the management of any great estate, or, indeed, of any considerable business. At Wintringham, Lord Carrington has a man employed, whose only business is to be constantly walking over every part of the estate in succession, in order to see if the fences are in order: if a post or rail is wanting, and the quick exposed, he gives notice to the farmer, and attends again to see if the defect is remedied." (*Young's Report*.)

3. Buildings.

Several good new farm-houses; old cottages of stud and mud, thatched; but new ones of brick, and tiled.

4. Occupation.

Farms on the Wolds from 500 to 1500 acres, on the rich lands 400 and 500 acres, downwards; many very small. The late Sir Joseph Banks declined throwing his farms together, because he would not distress the occupiers, though he lost considerably in rental by it. Farmers met with at ordinaries, liberal, industrious, active, enlightened, free from all foolish and expensive show, or pretence to emulate the gentry; they live comfortably and hospitably, as good farmers ought to live; and in my opinion, are remarkably void of those rooted prejudices which sometimes abound among this race of men. "I met with many who had mounted their nags, and quitted their homes, purposely to examine other parts of the kingdom; and had done it with enlarged views, and to the benefit of their own cultivation." Leases rare.

5. Implements.

Plough with wheel coulter used in the fen tract as in other fens; the wheel coulter being considered as better adapted for ploughing among stubble and couch-grass than the sword one. Plans given of a cover of canvass and boards for ricks, and a boat with a net fence round for conveying sheep; at best, we fear, but an expensive incumbrance on agriculture.

6. Arable Land.

Near Market Deeping the common fields in alternate ridges of pasture and arable, the latter gathered high; three to five horses used in both plough and cart teams; wood extensively cultivated by Cartwright, at Brotherstoft farm, near Boston. Parsley sown along with clover to prevent the rot.

7. Various.

"Rich grazing land the glory of Lincolnshire." In some places will carry six sheep per acre, or four bullocks to ten acres. One of the most extensive graziers was T. Fyde, Esq., M.P. at Boston. Very few orchards; some considerable young plantations on the Wolds, but not much old timber.

8. Improvements.

Most extensive drainages and embankments. Deeping Fen drained, which extends eleven miles to Spalding. 10,000 acres taxable, for maintaining the drains and banks, which are managed by a commission. Through all the fens what is called the soak exists; viz. water, supposed to be that of the sea, rising and falling in a substratum of silt: hence low-lying land always charged with moisture to a certain height. Sticklebacks sometimes sold at a half-penny a bushel, and used as manure. In the Wolds dry straw spread on the land and burned.

Embankments. Since 1650, 10,000 acres have been saved from the sea in the parish of Long Sutton, and 7000 acres more might now be taken in, by altering the channel of the river.

Holland Fen is a country that absolutely exists but by the security of its banks; they are under commissioners, and very well attended to.

At Humberstone there is a large piece taken in from the sea by a low bank, which is well sloped to the sea, but too steep to the land; so that if the sea topped it, the bank must break. Great tracts of valuable land remain yet to be taken in from the sea about North Somercots, and other places on that coast; but "I do not find that any experiments have been made in Sir Hyde Page's method of making hedges or gorse facines, and leaving the sand to accumulate of itself into a bank. Mentioning this to Neve, he informed me, that he had observed at least a hundred times, that if a gorse bush, or any other impediment, was by accident met by the sea, it was sure to form a hillock of sand." The extent of sand dry at low water on this coast is very great; the difference between high and low water mark extending even to two miles.

In the reparation of the banks which secure the marsh land from the sea, the frontage towns are at the expense; but in case of such a breach as renders a new bank necessary, the expense is assessed, according to the highest tides ever known, by level over all the country below such level of high water, under the direction of the commissioners of sewers; the distance from the sea subject to drainage will, therefore, vary according to the level of the country.

South Holland, grossly estimated at 100,000 acres, within the Old Sea-dyke bank, has long been an object of embankment. Ravenbank, the origin of which is quite unknown, appears to have been the third bank which had been formed for securing a small part of this tract from the sea, leading from Coubit to Tidd St. Mary's. About six miles nearer to the sea is another bank, called the Old Sea-dyke bank, which is unquestionably a Roman work.

A very curious circumstance is, that a fifth bank, called the New Sea-dyke bank, two miles nearer than the Roman one, remains, but it is utterly unknown when or by whom it was made. The new bank mentioned above takes in about two miles more in breadth. In staking the levels for making the new drain, it was found that the surface of the country, on coming to the Roman bank, suddenly rose six feet, being six feet higher on the sea-side than on the land-side, and then continues on that higher level, being the depth of warp, or silt, deposited by the sea since that bank was made.

The first navigable canal that was made in England is, in all probability, that which was made from Lincoln to Torksey; it is evidently a part of the Cardike, an immense Roman work, which served to prevent the living waters from running down upon the fens, and, skirting the whole of them, from Peterbo-

rough to Lincoln, afforded a navigation of the utmost consequence to this fertile country.

Some *irrigation*; and *warping*, on the Humber, where, as already described (444.), it was invented.

9. Live stock.

More attended to in this county than the culture of corn. The Durham short-horned cattle are preferred, but any sort fatten well, and there is little dairying.

Sheep. County carries one sheep and an half per acre at an average. Lincoln breed preferred; Leicester much tried, and crosses between them frequent; upon inferior land the Leicester preferred, as fattening easier; since the enclosure no folding; several ram societies.

Horses, of the heavy black kind a good deal bred both for carts and coaches; in various places saddle horses also; some farmers keep their horses all the winter in open sheds, with littered yards for them to go out and in at pleasure. Groundsel eaten, said to cure the grease; oats malted in salt water

given for three weeks or a month, found preferable to spring physic.

Rabbits. Several warrens on the wolds.

Geese formerly much kept in the fens, and plucked four or five times a year. "The feathers of a dead goose worth sixpence, three giving a pound. But plucking alive does not yield more than three-pence per head, per annum. Some wing them only every quarter, taking ten feathers from each goose, which sell at five shillings a thousand. Plucked geese pay in feathers one shilling a head in Wildmoor fen.

10. Political Economy.

Roads in many places made of silt; "dreadfully dusty and heavy in dry weather: on a thaw or day's rain like mortar." A number of canals, and, as already observed (3802.), the first in England, made from Lincoln to the sea. A fabric of brushes and sacking at Gainsborough; flax spun in various places. An agricultural society at Falkingham, established in 1796.

7802. RUTLANDSHIRE. 91,000 acres, resembling in soil and surface the uplands of the adjoining county of Lincolnshire. The western part of the county is under grass, and the eastern chiefly in aration. The soil is almost every where loamy and rich; and the agriculture partaking of that of Lincolnshire and Leicestershire. The operative classes seem more comfortable in this county, and more humanely treated by the proprietors and farmers, than in many others. The Earl of Winchelsea has made great exertions to this effect. (*Crutchley's Report*, 1794. *Parkinson's General Review*, 1808. *Marshal's Review*, 1812.)

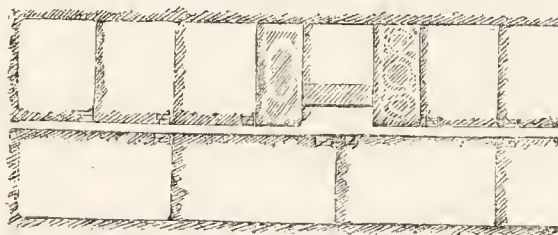
1. Buildings.

Some comfortable cottages built by the Earl of Winchelsea, containing a kitchen, parlour, dairy, and cow-house, &c. with two bed-rooms over.

Others for three cows, and with a calf-house, piggery, dairy, kitchen, living-room, and two bed-rooms over.

A third sort for operatives without a cow, containing a kitchen, pantry, closet in the stair over, and two bed-rooms, one with a fire. Several with small farms of from five to twenty acres attached. (*fig.* 1007.)

1007



2. Arable Lands.

Generally better managed than in Lincolnshire, and very productive. The barley said to be of very superior quality.

3. Pasture.

Chiefly upland. The custom of letting part of it to labourers, and also of taking in labourers' cows at so much per head, prevails, and is encouraged by the Earl of Winchelsea.

4. Several Orchards.

In several places the cottagers take small portions of fields from the farmers to use as gardens. At one place, three acres and a half is divided into fourteen gardens; and at Oakham, a field of three acres is divided into twenty-four gardens, and let at five shillings per garden.

5. Improvements.

Parkinson, one of the reporters, and a man of sound judgment, has altered his opinion on the subject of irrigation, and says, it is now in conformity with that of a correspondent who

thus writes to him:—"In my opinion watering renders the quality of the herbage and the land the worse for the process. Where land is tolerably productive, and in a situation where a quantity of grass food is not required, I should certainly not advise it. I think the land may be turned to better account without it. But I think there are many situations, particularly on gravel, sand, or open soils, where it may be very advantageous; the produce, by such means, is certainly much increased, and, in some instances, rendered larger when very little otherwise would be produced. Though the produce is increased, yet it becomes in time, in a few years, of so coarse a nature, and mixed with rushes and plants, that cattle frequently refuse to eat it; and when it is eaten, the appearance of the cattle proclaims it far from being of a nutritious nature." He adds, "I was formerly an advocate for irrigation, and am still on such soils as are described in the above extract; but having had since opportunities of viewing several water meadows which have been of long standing, which have operated to the disadvantage of both the herbage and land, I have been obliged, in a great measure, to alter my opinion."

6. Live Stock.

Not much breeding, but chiefly feeding. P. considers that much depends on the application to fallow, and is of opinion, that the large Durham ox did not eat more food to raise him to that enormous size, than some others would to bring them to half the size or weight at the same age. Nor is it at all probable that Lambert, of Leicester, who arrived at such an astonishing weight, had eaten more food than Powell, the celebrated pedestrian, who was a very thin man. An animal for the shambles is seldom too large if he has an aptitude to fatten: and much depends on the constitution of an animal in this respect.

A good plan for washing sheep at Burleigh; but not so simple as the Duke of Bedford's.

Horses of a very heavy, slow, unprofitable sort are raised in the county.

Of bees, 1176 hives kept by the cottagers.

7. Political Economy.

The Leicestershire and Rutlandshire Agricultural Society established in 1806, meet at Melton Mowbray and Oakham alternately. Less want of knowledge in this county than in most others.

7803. NORTHAMPTONSHIRE. 617,600 acres of billowy surface, rich in wood lands and pasture lands, but much behind in the culture of corn. The soil is almost every where excellent; and by the introduction of good husbandry, the marketable produce of the county might be amazingly increased. (*Donaldson's Report*, 1794. *Pitt's Report*, 1806. *Marshal's Review*, 1812.)

1. Geographical State and Circumstances.

Climate. Favourable both to health and vegetation; exempted from deep falls of snow and long-continued rains; highest point in the county supposed about 800 feet above the level of the sea, and there is neither mountain nor bog. Donaldson found that wheat harvest generally commences here about a fortnight earlier than in Perthshire.

Soil. Great part on a calcareous bottom, limestone, schistus, or slate, and the remainder of sandstone. The surface earths may be classed as strong and deep loam, light thin reddish soil, thin light clay, and fen and meadow.

Minerals. Clay, limestone, marl, freestone, and slate.

2. Property.

Almost wholly in large estates; thirty-seven of or above 3000*l.* a year, half of which are from 5000*l.* to 10,000*l.*; managed by stewards.

3. Buildings.

Althorpe, Burleigh, and Castle Ashby, noble mansions. Farm-houses "as badly constructed as improperly placed;" built of stone or brick, and covered with slate or straw; farmers and their farmeries crowded together in towns and villages; cottages of mud and thatch.

4. Occupation.

No large farms; 150 acres the average of open fields, and 200 the average of inland farms; few or no leases.

5. Implements.

"Plough a clumsy piece of work, with a long massy beam and timber mould, being drawn by four or five horses in a line." Donaldson says, a small plough, with two horses abreast, will make better work; but Pitt (who seems to know very little of the matter) joins with Smith of Tuchmarsh, who says, "I have heard and read much on the subject, and tried a great variety of ploughs; but it is ridiculous to assert that two horses can plough abreast in almost any part of this county. I have met with no ploughs which serve so well (!) or run so easy as the ploughs in common uses." So much for the ignorance and presumption of Farmer Smith, and the prejudiced

opinions of Pitt the reporter. A ribbed or plated roller, formed by letting in sixteen bars of iron lengthways of the roller, is found preferable either to a spiky or smooth roller for breaking clods.

6. Arable Land.

Fallow, wheat, and beans, the common rotation, but others, which include turnips and clovers, beginning to be introduced on the light lands. Most of the other plants in cultivation tried by amateurs or others. Woad cultivated by two woad growers, who live in the county; it requires rich old pasture land, for which the woad grower pays the landlord from 5*l.* to 7*l.* per acre, per annum, for two or three years, the farmer being compelled to give it up for that term, and to take to it again afterwards at the old rent. The land is ploughed early in spring, well harrowed, and sown broadcast, as thick as grain, by hand; a great deal of harrowing and dressing is necessary to bring it to fine tilth. When the plants appear, they are hoed, and kept perfectly clean, in a garden style of culture, and the crop appears somewhat like a broadcast crop of spinach; the leaves are gathered by hand, in baskets, three times in a season (except a plot sometimes saved for seed), and carted to a mill, where they are ground to a pulpy mass, by vertical wheels, crossed with iron plates, and moved round by horses: this pounce, or jelly, is then formed into balls, by hand, and dried on hurdles, in a shed; these balls are afterwards broken up, and fermented, and finally dried in small lumps, somewhat resembling horse-dung in colour and appearance; it is then packed up in casks for use.

Onions cultivated to great perfection about Northampton; 220 quarters known to have been sent to Daventry fair at one time.

Tobacco cultivated by some farmers for the purpose of dressing sheep for the scab.

Furze in a few places for oven-fuel.

7. Grass.

Supposed to cover 575,000 acres; 40,000 acres in meadow, on the borders of the Nen and other rivers. One farmer says, "A great improvement on all mowing meadows, incapable of

being watered, is to graze, once in two or three years as bare as possible, and finish with store sheep; shut it up at Christmas for mowing; this is as good as a top-dressing." Feeding sheep and cattle the chief application of the grass lands, and next, dairying and breeding horses.

8. Gardens and Orchards.

Good market gardens and orchards about Northampton; all common articles grown there well, but melons, grapes, peaches, and pine-apples to be had from London cheaper than they can be grown in the county.

9. Woods and Plantations.

Very extensive; there are forests, chases, purlieu woods, and woods and plantations being freehold property. Rockingham forest the most considerable, nearly twenty miles in length, and covering 8 or 10,000 acres. Whittlewood eleven miles, and 7000 acres, with Salcey forest, making in all 20,000 acres: the chases and other classes are supposed to amount to 20,000 acres more, making in all 40,000 acres of woodland in the county. The forest lands are in general very unprofitably managed; the Crown has a right to the timber, the Duke of Grafton and others to the underwood, and the township to the pasturage, &c.; woods which are private and entire property are better managed.

7804. YORKSHIRE, 3,698,380 acres divided into three Ridings, each of which is as extensive as the generality of other counties.

7805. WEST RIDING OF YORKSHIRE. 1,568,000 acres of irregular country, hilly and mountainous towards the north, and more level on the east. It contains a great extent of surface well adapted for husbandry, and is the seat of large and extensive manufactures. A survey of this Riding, of singular ability and interest, was made by three Scotch farmers; and the reprinted copy, as it contains the notes of several gentlemen of the county, will in future times be considered as a curious document; displaying as it does local opinions so different from those considered as liberal and enlightened. (*Brown's West Riding*, 1799. *Marshal's Review*, 1818. *Smith's Geological Map*, 1821.)

1. Geographical State and Circumstances.

Climate, moderate and healthy, excepting on the low surface near the Ouse; rain at Sheffield about thirty-three inches in the year.

Surface irregular, but the middle and eastern parts nearly level; arable lands generally enclosed with walls and hedges.

Soil various, from deep strong clay to peat.

Minerals. Coal, lime, ironstone, lead and some copper, which have been wrought for ages past.

Rivers. Ouse, Don, Calder, Aire, and Wharfe, all considerable, besides others of lesser importance.

2. Property.

Much divided, but some large estates, as those of the Duke of Norfolk, E. Fitzwilliam, E. Harewood, &c.

3. Buildings.

Wentworth House one of the largest and most magnificent in the kingdom; farm-houses bad and badly situated as in most English counties; Lord Hawke has erected a commodious and elegant farmery for his own use. Great want of cottages for farm operatives.

4. Occupation.

Farms small; for one of 400 acres a dozen under fifty; occupier of 100 acres styled a great farmer; few leases; the tenants on one estate warned off because they had become methodists; tenantry in general much plagued by attorney stewards, who must have business or make it.

5. Implements.

Rotheram plough general over the whole district, but one-horse carts and other improved implements, as well as better ploughs, are wanting.

6. Arable Land.

Round manufacturing towns great part of the land held by manufacturers, that by farmers not well managed compared with Scotland, but tolerable compared with other districts of England. No grain will ripen on the eastern moorlands at an elevation of 800 feet; but on the calcareous wolds of the East Riding it ripens considerably higher, and at 500 feet better than here at 800. Such is the effect of a calcareous soil. Besides the usual crops, some flax, rape, liquorice, rhubarb, and weld, cultivated. Some excellent remarks on fallows.

7. Grass.

Great part of the county under old pastures, including some meadows, chiefly applied to the feeding of horned cattle: cattle

10. Live Stock.

Cattle of the county, the long-horned breed: but various others introduced for fattening and the dairy.

Sheep of various breeds; a good many new Leicesters.

Horses of the strong black breed, bred for the coach, the army, or large waggons. Blood horses formerly bred, but left off, as the least blemish renders them unsaleable.

Hogs, a breed between the Berkshire and the Tonquin.

11. Political Economy.

Bad roads, but many handsome bridges; some canals. Manufactures; — shoes for the army and navy, and exportation; bone lace, woollen stuffs, as tammies, callimancoes, and everlastingings. Several small friendly societies for the promotion of agriculture, consisting chiefly of farmers. The Lamport Society is one of those which was founded in 1797, meets at Lamport; it has a fund for purchasing books on agriculture and domestic economy, and seems to be a description of association very commendable. A great source of improvement would be the breaking up of the inferior grass lands, and the temporary laying down of the continually cropped tillage lands. Donaldson has drawn an able comparison between the management of lands in the Carse of Gowrie, in Perthshire, and those of Northamptonshire, which shows how very far behind the latter county is in arable culture.

generally made fat on grass, and finished by stall feeding on turnips; sheep sometimes fed on turnips, by hurdling. Grazing much better understood than aration.

8. Gardens and Orchards.

A particular species of plum grows at Sherborne and in the neighbourhood, called the winesour. It grows well both upon gravel and limestone, is hardy, a good bearer, and answers upon any soil; but does not bear so well, nor is its flavour so good, on any as on limestone or gravel. On a strong deep land, the trees run too much to wood, and do not bear fruit in proportion. These plums blossom better than any other sort, and are produced from suckers. The fruit sells from 21s. per peck, when sound and good, to 4s. 6d. when cracked and damaged. They are easily hurt by rain. Plants are to be had from most public nurseries, and in gardens they should be planted on a layer of lime or chalk.

9. Woods and Plantations.

Much oak and ash wood grown, and a ready market found at the shipping and manufacturing towns.

10. Waste Lands.

Two hundred and sixty-five thousand acres capable of cultivation.

11. Improvements.

Warping the most remarkable; ably described by Lord Hawke, and Day of Doncaster.

12. Live Stock.

A great variety of breeds of cattle and sheep in use, but no one generally preferred. Near Leeds, when milk tastes of turnips, a tea-cup full of dissolved nitre is put among eight gallons of milk, which entirely removes the flavour. Horses generally used in draught: not many bred excepting in the eastern part of the district; sort in use among the farmers a small hardy race.

13. Political Economy.

Many good and many bad roads; various canals. Numerous manufactures of shalloons, callimancoes, flannels, and every branch of woollen goods. At Sheffield every kind of cutlery, since Chaucer's time; at Rotherham, iron-works. These and other manufactures the cause of the wealth of the West Riding.

14. Means of Improvement.

Leases, division of commons, enclosing of wastes, better rotations, &c.

7806. NORTH RIDING OF YORKSHIRE. 1,311,187 acres of bold hilly country, with some fertile vales and extensive moor lands, chiefly remarkable for breeding horses, and especially the sort known as Cleveland bays. (*Take's Report*, 1799. *Marshal's Review*, 1808. *Smith's Geological Map*, 1821.)

1. Geographical State and Circumstances.

Climate dry, like that of other districts bordering on the German Ocean. Cold east winds during the first half of the year. Milder in June, when west winds begin to prevail, vegetation not vigorous till June.

Soil and surface: on the coast, clays, and lightish soil on alum strata; a loam upon freestone, and in some valleys west of Whithy a deep rich soil: of Cleveland, fertile chalk, and surface hilly; vale of York generally a rich soil.

Minerals. Inexhaustible beds of alum in the hills of the coast and Cleveland; and the only alum works in the island carried on there; pyrites being found in the alum mines, sulphur was formerly extracted from them; but as it required a good deal of coal, and pyrites are equally abundant in the coal at Newcastle, the manufactory of sulphur was transferred to the latter place. Some coal and ironstone in the moors, but not much worked; also copper, lead, freestone, slate, marble, marl, &c. little worked or abandoned.

2. Property.

One third of the Riding possessed by yeomanry; rent of estates from 500*l.* to 18,000*l.* per annum; many gentlemen's seats, and the proprietors reside most part of the year on them; tenures mostly freehold.

3. Buildings.

Mansions and farm-houses, as in the West Riding, but rather inferior; cottages decidedly inferior; small and low,

rarely with two rooms; damp and unwholesome hovels. Close wainscoted beds used, as in the poorer parts of Scotland, which are sources of insects and infection, and every way unwholesome.

4. Occupation.

Farms on the whole small, many very small: farmers sober, industrious, and orderly; most of them have been educated, and educate their children. Few leases.

5. Implements.

Rotheram or Dutch plough: hay sweep for drawing hay together with a horse and a simple sort of cart (*fig.* 1008. *a*) in use, formed almost wholly of timber, and to be drawn by one, two or three horses abreast (*b*); wheels entirely of wood (*c*); when to be emptied, the shaft horse is taken out, but not the others. Another variety for harvest work (*fig.* 1009.)

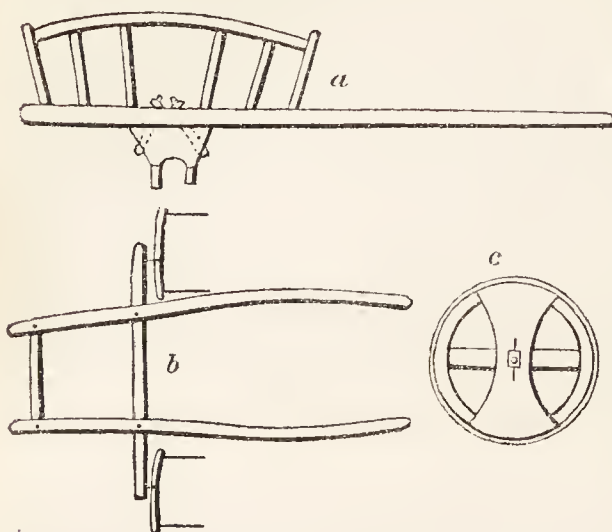
6. Arable Land.

In the vale of York one third in tillage; about Cleveland one half; on the moors much less. Culture and rotations as in the West Riding. Rye more frequently sown than wheat on the light sandy soils; often mixed with wheat, and then called Meslin.

Tobacco much cultivated a few years prior to 1782 in the vale of York and Ryedale. In the latter district it did not excite the notice of regal authority; and was cured and manufactured by a man who had formerly been employed upon the tobacco plantations in America; who not only cured it pro-

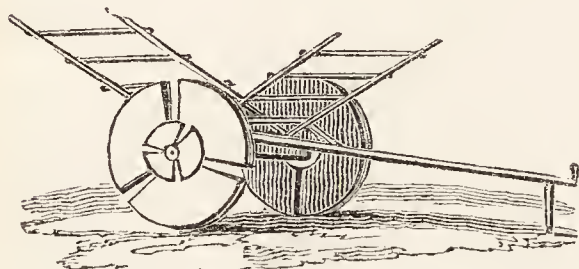
perly, but gave it the proper cut, and finally prepared it for the pipe. But in the vale of York the cultivators of it met with less favourable circumstances: their tobacco was pub-

1008



licly burnt, and themselves severely fined and imprisoned. Penalties, it was said, were paid to the amount of thirty thousand pounds. This was enough to put a stop to the illegal cultiva-

1009



tion of tobacco; but, perhaps rather unfortunately, it has likewise put a stop to the cultivation of that limited quantity, half a rod, which the law allows to be planted for the purposes of physic and chirurgery, or destroying insects.

Mustard grown in considerable quantities in the neighbourhood of York, and fields of it may be met with in other parts of the Riding. It is prepared for use in the city of York, where there are mills and machinery for the purpose; and it is afterwards sold under the name of Durham mustard; sown either on land pared and burned, or prepared and manured as for turnips. Seed, one to two pecks per acre broadcast, in the early part of May. No culture whilst growing, except hand-weeding, if necessary. Shorn with the sickle in September, and generally stacked in the field, and threshed out upon a cloth, at the convenience of the farmer. Two quarters per acre is thought a good crop.

Teasel grown on strong soils; seed, two pecks a little before May-day; surface dug or forked over in June, October, and Lady-day; reaped in August; 10 pecks an acre a good crop; each pack 1350 bunches, of ten teasels each; price, 3 to 5 guineas per pack.

7. Grass.

Old pastures and meadows very badly managed; uplands overrun with moss and ant-hills; meadows with rushes; and so neglected, that what would be worth 200*l.* under a proper course of husbandry, is dear at 7*s.*; chiefly devoted to the dairy.

8. Gardens and Orchards.

Have made but little progress, in this Riding owing to the want of manufacturing towns to create a demand; farmers' gardens, as in most places, much neglected.

9. Woodlands.

Of small extent; a good deal of timber in hedge-rows in various places.

10. Live Stock.

Short-horned cattle chiefly prevalent. Stall feeding carried to less extent than dairying. Cows taken in at Martinmas, and fed on turnips, and straw or hay if there are no turnips; butter chiefly made and salted in firkins, and sold to the factors, who ship it to London; a good many cows brought up for London, and any surplus stock for the Lincolnshire graziers.

Sheep. In the bleaker parts, the Cleveland breed, large, coarse-boned, slow feeders, and the wool dry and harsh. All the new breeds introduced, and several professed ram breeders in the vale of York.

7807. EAST RIDING OF YORKSHIRE. 819,200 acres of moderately wavy surface, intersected with numerous, deep, winding valleys; not remarkable either for its arable lands or pasturage; but productive of horses for the coach and saddle, and of the excellent Holderness breed of cows. (*Leatham's General View*, 1794. *Strickland's View*, 1812. *Marshal's Review*, 1812. *Smith's Geological Map*, 1821.)

1. Geographical State and Circumstances.

Climate of the wolds severe and variable; N. and N.E. winds prevail in winter and spring; in the vales milder; mild, but not very healthy, on the Humber; rain at Hull twenty-seven inches and a half yearly at an average.

Soil of the wolds calcareous loam; of Holderness fertile clay and stiff retentive clay. On the banks of the Humber, from Paul nearly to Sperrn Point, there are 13 or 14,000 acres of warp-land, of a strong clayey loam, the productiveness of which can hardly be equalled.

Horses. This Riding long famed for its horses, particularly those of Cleveland. In the northern part of the vale of York a light breed for saddle and coach; in Cleveland, a fuller-boned horse, very strong and active, and well adapted for either plough or coach. In all the other districts horses are generally bred; on the western moorlands Scotch galloways are put to the stallions of the country, "and rear a hardy and strong race in proportion to their size." Before the war mules were bred, and sent to the West Indies. Some farmers do not breed, but buy colts and work them till four or five years old, and then shoe them for the first time, and sell them to the London dealers for coach horses.

The farmers who breed horses, generally breed from those mares which are employed in the business of the farm; these are often worked until the very time of foaling, after which they have usually two or three weeks' rest, before they are again taken to work; the foal, during the time the dam is working, especially whilst it is young, is shut up in a stable; and it is the practice of some, before she is suffered to go to the foal, after returning from work, to bathe her udder with cold water, and to draw most of the milk from it, to prevent the milk, which may have been heated by labour, from having any hurtful effect upon the foal. Some continue this practice as long as the foal sucks: others, after the foal has got sufficient strength to travel along with the mare, take it along with her into the fields, and frequently suffer it to suck, from an opinion, that by the milk being frequently drawn, less danger arises of its being heated, or of possessing any quality prejudicial to the foal. The general time of foaling is about May-day (from which day the age of all horses is reckoned), and that of weaning about Michaelmas, when the foals are put into good after-grass, or the best pasture the farmer possesses: they remain there as long as the weather permits (if there be sufficient food), and, on the approach of winter, have a little good hay given them, where there is a stable, or hovel, that they can go into at their pleasure. The colts are usually gelded in the spring following, and in summer are allowed only an inferior pasture; the next winter they make their living in the fields, or in the straw-yard, except they are intended to work in the spring, which is frequently expected of those of a strong kind: such are rather better kept as the time of labour draws nigh, and are only put to light and easy work, and generally work only half a day at once. Some keep their colts a year longer, before the operation is performed, and find that such become the stronger and handsomer horses. The foal always receives a great check by being weaned, which it does not well recover before it gets the fresh pasture of the following summer. The foals which are gelded at one year old receive a second check, at the very time they should begin to recover from the first; whereas at two years old they appear to be in the best condition for the operation, and recover at least as well as at one year old, and are much improved by the keeping of the preceding year.

Exportation of horses. The horses which are sold for the London market, if for the carriage, are chiefly bay geldings, with but little white on their legs and faces, those which have much white, with chestnut, roan, and other unusually coloured horses and mares, generally do not bear an equal price in the London market; but with other slight and undersized horses, are more sought after by foreigners, and eagerly purchased by them for exportation; or are exported by people of this country, who carry them to the foreign markets, and ultimately obtain a price equal to that obtained for those sold at home: by these means of exportation, contrary to an usually received but ill-founded opinion, has a strong tendency to reduce the price of those horses which are calculated for the home market; and since as many fillies as colts are naturally bred, and one third of the colts at least will either have too much white for the home market, or be of some other colour than that which is fashionable at the time, if the breeder had not a market for those, which appear to be two thirds at least of all he unavoidably breeds, he would be compelled to put such a price upon the one third which happened to suit the home market, or variable taste of the moment, as would pay for the other two thirds; which last would either be unsaleable, or fetch very inadequate prices. The consequence naturally flowing from this would be, that the price of horses used at home would be far greater than at present, when a foreign demand procures to the breeder nearly as good a price for the horses that would otherwise be useless and unsaleable, as for those which are valued at home.

Rabbits are kept in one or two warrens; in one the silver grey is kept, the skins of this variety being worth double those of the greys: not used for felts like the common skins, but dressed as furs, and exported to China to be worn by the Mandarins.

11. Political Economy.

Roads in an improving state; bridges better attended to than in most counties; but guide-posts neglected, which an annotator on Tuke's report justly remarks, is a sort of reverting to barbarism; as an attention to these sort of minutiae is one of the most striking marks of civilisation. Various canals.

Manufactures of sail-cloth and cordage at Whitby and Scarborough; at various places in its neighbourhood, alum works; 4000 tons of this article annually shipped from Whitby; linens, cottons, woollen, and paper manufactured in various places.

Sunk Island on the Humber is a modern creation by that estuary. It first began to show itself about 1667, at ebb tide, and as no man pretended title to it (it being a detached island), a grant of it was made by the crown in the same year. In 1787 1600 acres of the land were embanked and under tillage, producing a rental of 900*l.* a year, with a chapel and several farm-houses erected on it. That part of Sunk Island which was first embanked was originally about two miles from the shore, and many persons are still living who recollect vessels passing between it and the mainland, to which it is now united by a

bridge across a narrow channel, serving as a drain to the adjacent country. It contains at present within the banks about 4700 acres and twenty-four families, and is continually increasing in size, an extensive tract having been recently embanked, with a probability of its being still further enlarged.

Minerals. Chalk and a very hard shelly limestone, producing a lime little valued either by the farmer or builder. Chalk of the wolds much harder than that of the southern counties. Marl in many places. Gypsum in some places, but no mineral veins of coal, and in many places not even clay for bricks.

2. Property.

Less divided on the East Riding than in other parts of the county; perhaps less than in most parts of England; which arises a good deal from the nature of the county: one half of wolds where land is held in little estimation, and occupied in larger tracts; the other a flat low country, partly rich and clayey, and partly sandy and barren. Most of the families have possessed their estates for many centuries, and some from the Norman conquest: largest 15,000*l.* a year; ten at 10,000*l.* a year. Only three noblemen have seats in this Riding.

3. Buildings.

Seventy-four manorial houses, of which twelve are going to decay; nineteen let to tenants, or remain empty; forty-one occupied by their owners (*Temp. Eliz.*); ninety-two families bearing arms resident in the county.

Farm-houses generally good, excepting on the wolds, where they are built of chalk, thatched, and miserably bad; generally in villages, excepting those built lately.

Cottages more comfortable than in many places; generally two rooms below and two bedrooms over them: a disposition in the proprietors to let their cottages go to decay.

Village cow club. A plan for insuring cows having been lately adopted on an extensive scale, and with striking success, in the north of Lincolnshire, from which it appears that an average payment of about three halfpence per cow per week (or six shillings per year) is fully adequate to replace the ordinary losses of cows by death, it is proposed to institute a similar club in the contiguous parts of the East and North Ridings of Yorkshire, with a view of securing to the labourer and his family, at a trifling expense, the great benefits of that useful animal, without his risking more than one sixth part of her value, upon certain conditions.

4. Occupation.

Farms in general small; one or two of 1200*l.* per annum, but from 200*l.* to 20*l.* more common. Leases so rare that the surveyor could not recollect of one, unless under suspicious circumstances, where something incorrect is aimed at, some advantage intended to be given or taken; where either the landlord wanted something more than customary from the tenant, or the tenant was disinclined to trust his landlord: great estates are let in full confidence in this Riding, where a lease was never asked for, probably never wished for; because the tenure is equally secure, and more permanent without than with one. Many estates have been occupied by the progenitors of the present tenants, during two, three, or four generations.

5. Implements.

Waggons here of a bad construction; but well yoked in the German manner. The four horses are yoked two abreast, in the same manner as they are put to a coach, two drawing by the splinter-bar and two by the pole; those at the wheel drawing also by a swinging bar, which the wheel-horses of every carriage ought to do, as they thereby obtain considerable ease in their draft, and are less liable to be galled by the collar than those which draw by a fixed bar; the driver then, being mounted on the near-side wheel horse, directs the two leaders by a rein fixed to the outside of each of their bridles, they being coupled together by a strap passing from the inside of each of their bridles to the collar of the other horse. In this manner, when empty, they trot along the roads with safety and expedition; and when loaded, the horses being near their work, and conveniently placed for drawing, labour with much greater ease and effect than when placed at length. Were the wagon, indeed, of a better construction, the team would be excellent.

The peas-hook and the bean-hook, both made out of old scythe-blades, and used in reaping peas and beans, are peculiar to this Riding; as was the lime-burner's fork till lately. (See fig. 682. b, c.)

The moulding sledge is a useful implement for levelling the small inequalities of meadow and pasture land, and spreading the dung dropped by the cattle. It is a frame of wood about

five feet square (the sides of which are about four laches thick to give it weight and strength), having three bars of iron fixed to the lower side, the points of which are thinned to sharp edges. When in use, some thorns are drawn under the hinder wooden bar, and above the middle one, to which they are fixed by cords. If it is wanted to be removed from one field to another, it is turned the other side up, which preserves the edges of the bars from injury. It is drawn by two horses, and will go over a great extent of land in a day.

6. Enclosing.

The taste for this has been carried too far, and land enclosed which has not and probably never will repay the expense.

7. Arable Land.

Two thirds of the wolds, and one third of the rest of the Riding, under the plough; fallow, wheat, oats, or fallow, barley, beans, common rotations.

8. Grass.

The marshy meadows adjoining the Derwent, a few grazing pastures in Holderness and Howdenshire, and the small garths or paddocks in the immediate vicinity of the towns and villages, form the principal part of natural grass lands.

The salt-marshes on the outside of the embankments are of no great extent. Unless the mud is so elevated as to be constantly above water for a few days at neap tides, no plants take possession of the surface; but when vegetation can go on, the first plant which takes possession is the *Salicornia* or samphire, and next the *Poa maritima*, which in a short time covers the surface with a close short sward. A few sheep are occasionally put on it when not too much dirtied by the mud of the spring tides.

In laying land to grass, caraway and parsley sown among it by some, to preserve the health of the sheep.

9. Gardens and Orchards.

Almost unknown, excepting among the higher classes; farmers rarely use any other vegetable than potatoes and turnips; cottagers cultivate their gardens with more care than the farmers.

10. Woodlands.

Of no great extent in proportion to the Riding; extensive plantations made on the wolds.

11. Improvements.

Holderness drainage an extensive work of the kind, on the east side of the river Hull; it extends over nearly 12,000 acres, and is managed by commissioners. Various other extensive drainages.

12. Live Stock.

Holderness cattle, remarkable for their large size and abundant supply of milk, prevail universally. This breed is supposed to have been introduced from Holland about a century ago, and improved by attentive management. The late Sir George Strickland the greatest modern breeder in the district. Breeding a principal object in most parts of the Riding, and feeding in Holderness when the pastures are rich.

Sheep formerly the Holderness breed, resembling that of Lincolnshire and the Wold sheep; now the Leicester and various other breeds.

Horses for the coach and saddle, the grand branch of breeding in this Riding, and as many or more produced, in proportion to its extent, than in any other. But it is allowed by all that the breed has of late much degenerated, owing to the inattention of the farmers. About twenty years ago, a cross of blood was introduced, by which, though good saddle horses were produced, the coach horse was lost. This error discovered, an opposite and still more pernicious one was produced by the introduction of heavy black stallions from Lincolnshire. These produced a mongrel breed, which will not be got rid of for several generations. In breeding, some castrate the foal while sucking, and think it a preferable practice to that of the North Riding.

Rabbits. About twenty warrens, containing together probably 10,000 acres.

13. Political Economy.

Not more than 140 miles of turnpike road in the whole Riding; few of these good, and the cross roads and lanes very bad; manufactures few; white lead, glue, glass, iron-foundry, oil-mills, cordage, sailcloth, patent whalebone, brick, tile, pottery, &c. at Hull. White-lead and Spanish-white for whitening prepared from chalk, at Hessel. Howden coarse canvass for mail bags; near Driffild spinning and weaving tow; other manufactures near York. Several agricultural societies; one for books and implements at Howden.

7808. DURHAM. 582,400 acres of surface, in some places mountainous, and in most places hilly; the soil in great part poor; the agriculture generally approaching the best model, that of Northumberland; and the county distinguished by the Durham or Teeswater breed of cattle, and by its lead and coal mines. The celebrated farmer and breeder Culley was a native of this county, and farmed here as well as in Northumberland. (*Granger's General View*, 1794. *Bailey's General View*, 1810. *Marshal's Review*, 1818. *Smith's Geological Map*, 1824.)

1. Geographical State and Circumstances.

Climate fine and mild in the lower districts; but on Crossfell, the highest land in England, being 3400 feet above the level of the sea, snow frequently lies from November till the middle or end of June. General time of harvest from the beginning of September to the middle of October.

Soils principally clay loam and peat; the latter prevails in the western part of the county or lead-mine district; there is a tract of calcareous soil in the interior of the county.

Minerals: coals found over a considerable portion of the county, workable to the extent of 100,000 acres; those in the northern parts of the county wrought for exportation, in the western and southern parts for land sale only. In various parts of the coal districts are dykes or fractures (fig. 1010. a, b), and consequent derangement of the strata, which throw the beds of coal (c c) on one side of the dyke often many feet up or down. The fissure between being commonly filled with clay, stops the water in its course along the different beds (d, e), interrupts the drainage, and greatly damages the working of the coal.

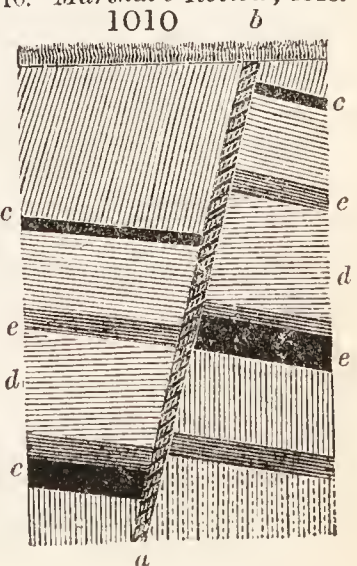
Lead-mines numerous in the western district; the ore mostly in vertical fissures of limestone and other rocks like the dykes.

Millstones, grindstones, freestones, slates of the grey or free-

stone kind, silver sand, limestone, whinstone, clay stone or black metal stone, and yellow ochre, also found.

Water. Salmon fishery on the Tyne has greatly declined, owing to the building of weirs, which prevent their getting up. Bailey remarks, that if dams of this description were put across the river Tweed, a revenue of nearly 16,000*l.* per year, received for rents of fishings, and 60,000*l.* a year, the value of the fish taken in that river, would be reduced to a mere trifle, in a few years.

Salt springs, from which salt is made near Britt and other places. A spa



or salt sulphur spring near Durham, and another on Lord Durham's estate, with public baths and dressing-rooms. Various others of less note.

2. Property.

Largest estates, 20,000*l.* to 22,000*l.* a year; several from 1000*l.* to 3000*l.*, from which they descend by regular gradations to the smallest sums. Some estates let by proposal; but the general mode is to ask a rent, and treat with tenants six or seven months before the existing leases expire.

3. Buildings.

Generally of stone and slate; cottages of one story, covered with thatch or tiles.

4. Occupation.

Largest farm about 1000 acres, greatest number from 150 to 50 acres. The larger farmers almost only those who have made improvements; among these, Messrs. Culley and Charge first led the way, and have been followed by Messrs. Collins, Mason, Taylor, Trotter, Nesham, Seymour, and many others, by whose exertions and judicious selection of stock this district will be lastingly benefited.

Greatest number of small labouring farmers greater slaves than their servants, being generally employed through the summer, in some kind of work or other, from four o'clock in the morning till eight at night; and in every other season of the year from twilight to twilight; and may truly be said "to rise early, take rest late, and eat the bread of carefulness."

Leases, three, five, and seven years, excepting church and corporation leases for 21 years, and lives. Those farms let for short terms remain stationary, as no prudent man will lay out his money in improvements, for which, when completed, he will be rewarded by an advance of rent, proportioned to the improvement he has made.

5. Implements.

Swing ploughs of the Rotherham kind; of late the Small's plough; various other good implements, and in many parts now (1850) the improved forms of Northumberland and Berwickshire.

6. Enclosing.

On dry soils hedges are frequently planted on a raised mound, forty inches broad, and the height twelve inches; a small ditch is cut on each side to make it, and the quicks are planted in the middle. In this mode the land may be ploughed nearly to the mound, and when the thorns are grown to a sufficient height, almost close to the hedge. When they are five or six years old, every other stem is cut clean off, within two or three inches of the surface, and the remaining ones stripped of their principal branches; then stakes of thirty inches high are driven in at proper distances, and the splashing stems, having a slight cut on one side to make them bend easier, are wound amongst the stakes at an angle of about twenty-five degrees, and a single edder is wound round the top to keep the stakes tight.

7809. NORTHUMBERLAND, including those detached parts of the county of Durham, called Northamshire, Islandshire, and Beddingtonshire, comprehends a surface of 1,267,200 acres, chiefly mountainous or breeding districts, but including 450,000 acres proper for tillage. The celebrity of this county both for its tillage and breeding is well known. Here turnips were first extensively cultivated in the drill manner, and the best principles of breeding practised by Culley. To this gentleman and Bailey agriculture owes much: the latter was, perhaps, one of the most enlightened and accomplished of modern agriculturists. (*Bailey and Culley's General View, 1805. Marshal's Review, 1808. Smith's Geological Map, 1824.*)

1. Geographical State and Circumstances.

Climate subject to great variation of temperature; snow to a considerable depth on the mountains, when there is none in the lower districts; weather runs in extremes; very cold in spring, and seldom mild before June.

Soil and Surface. Strong fertile loam along the coast; sandy, gravelly, and dry loam on the Tyne, from Newborn to Haltwhistle, on the Coquet about Rothbury; on the Aln, from Alnwick to the sea; down Tweedside, but chiefly in the vales of Breamish Hill and Beaumont. The hills surrounding the Cheviot mountains are mostly a dry sharp gravelly loam. Moist loam occupies a large portion of the county, unsafe for sheep, and unfit for turnips, and peat earth prevails in the mountainous districts.

The aspect of the surface is marked with great variety; along the sea-coast it is nearly level; towards the middle more diversified, and thrown into large swelling ridges, formed by the principal rivers. These parts are well enclosed; in some places enriched with wood and recent plantations, but the general appearance is destitute of those ornaments. The western part (except a few intervening vales) is an extensive scene of open mountainous district, where the hand of cultivation is rarely to be traced. Of the mountainous districts, those around Cheviot are the most valuable, being in general fine green hills, thrown into numberless variety of forms, enclosing and sheltering many deep, narrow, and sequestered glens.

Minerals. Coal in abundance in the greatest part of the county: it is like that of Durham of the caking kind, and is found in the south-east quarter of the best quality; quantity exported, chiefly for the London market, 956,250 London chalders. Calculated that the whole coal of the counties of Newcastle and Durham will be exhausted in 550 years. Limestone, stone-marl, clay-marl, lead-ore, and ore of zinc in small quantities; freestone, whinstone, and iron are all worked.

Water. The Tyne and Tweed have been long celebrated for their salmon fisheries: in the latter a rent of 800*l.* a year is paid for a fishing of two hundred yards in length, near the mouth of the river; and the same rent is paid for each of two other fishings above the bridge, not more than two hundred and fifty yards in length each. The fish taken here are, the salmon, bull-trout, whiting, and large common trout, and nearly the whole of them sent to London; in the conveyance of which, a great improvement has taken place of late years, by packing them in pounded ice; by this means they are presented nearly as fresh at the London market, as when taken out of the river. For the purpose of carrying them,

7. Arable lands.

Ploughing generally well executed, but in some places the subsoil prevents sufficient depth of furrow, *i. e.* six inches. The turnip culture, rotations, and general management of arable land, the same as in Northumberland; that is, of the most improved kind; seventeen tons of Rüta bāga are equal to thirty-one tons of white turnip in feeding cattle or sheep.

Mustard was formerly much grown in this county, and Durham mustard was proverbial for its excellence. At present a crop of mustard is rarely met with. It is generally sown upon pared and burned land in April, one pound per acre. The produce about twenty bushels per acre; and price from eight to sixteen shillings per bushel.

Potatoes in the village of Hamstely have been the principal article of trade, and the principal employment of several families for eighty years; they are very particular in having good sets, each with two eyes; use reddish or pink sorts, plant in March and April, and both horse and hand-hoe; no curl appears among them, but sometimes they "run wild;" or tend to that state, producing more flowers than usual, and continuing flowering much later, sometimes till Michaelmas, and producing few tubers and slender stems. Whenever this is observed, the tubers of such potatoes are no longer used for propagation.

8. Grass.

Not much old surface, what there is chiefly upland.

9. Woods and Plantations.

Scampston elm, from a place of that name in Yorkshire, but supposed originally from America, will make shoots from grafts, in one year, of 5 or 6 feet; introduced in young plantations by Messrs. Falla, eminent nurserymen of Gateshead; vale of Derwent well wooded; Sir J. Eden a great planter.

10. Embankments.

Begun on the Tees in 1740, and about 1500 acres secured between that period and 1800.

11. Live Stock.

Short-horned cattle. The famous Durham ox bred by Charles Colling of Kellan, in 1796.

Sheep. Teeswater and Leicester breed; stock bred, reared, and fed in the most scientific manner, especially by the larger farmers mentioned above (4).

12. Political Economy.

Turnpike roads first made in 1742; materials, whinstone, limestone, river gravel, and freestone. Roads excellent where materials are broken sufficiently small: they are also in good repair. Milestones on some roads, hollow triangular prisms of cast-iron, with projecting letters and figures. They are two and a half feet high, and fixed on an oak post, four and a half feet long, sunk two and a half feet in the earth. Guide-posts much wanted. No iron railways, and no public roads or canals.

Manufactures. Wrought iron foundries, glass-houses, potteries, salt, copperas, sal ammoniac, coal tar, paper, woolleu, cotton, and linen cloth. Several agricultural societies; the first established at Darlington in 1783.

and keeping up a constant and regular supply, vessels called smacks sail three times a week, and being purposely constructed for swift sailing, frequently make their run in forty-eight hours. These vessels are from 70 to 120 tons burden; on an average twelve men are employed in each vessel, and make about fourteen voyages in a year; and not less than 75 boats and 300 fishermen are employed in taking the fish in the River Tweed.

2. Property.

One estate upwards of 40,000 acres, the rest vary from 10 to 20,000; small estates rare in the northern part of the county. Few counties in which estates have been so rapidly improved; several instances of the value trebled in forty years; principal cause letting large farms on twenty-one years' leases. Usual mode of letting farms is to fix a rent six or twelve months before the expiration of the lease; but upon one of the largest estates in the county (the Earl of Tankerville's), the tenants have an offer of their farms two years and a half or three years before the expiration of the lease, which is a mutual benefit to both landlord and tenant, and is attended with so many advantages, that it is in a fair way of being generally adopted.

3. Buildings.

Farmeries formerly very shabby and ill contrived, now totally different. The most approved form of distributing the various offices is, on the east, west, and north sides of a rectangular parallelogram (*fig. 1011.*) which is generally divided into two fold-yards for cattle of different ages, the south being left open to admit the sun; and for the same reason, and also for the sake of cleanliness and health, the farm-house (*a*) is removed in front thirty or forty yards; between which and the south wall of the fold is a small court for coals and young poultry; the barn (*b*) is 18 feet by 60, with threshing-machine driven by horses, water, wind, or steam; on each side arc sheds (*c c*), over which are granaries; beyond these, as wings to the main square, are sheds (*d d*), upon which are built corn-stacks. One of these sheds is for wintering yearling calves, the other for holding implements of the larger kind. On the east of the main square is the stable (*e*), and in the west a house for cows and fattening oxen (*f*), each 16 feet by 48 feet. Over the pigsties (*g*) are poultry houses which open into the court-yard of the house, as the piggeries do into the fold-yards for wintering young cattle (*h h*).

Cottages of stone and lime and tiled; floor of lime and sand; the living room fifteen feet by sixteen, and the cow-house nine feet by sixteen.

4. Occupation.

Farms generally large in the north, some from 200l. to 400l. a year; in various parts farms from 50l. to 100l., and from 100l. to 1000l. or 1500l. a year. The capital necessary for such farms entitles the farmers to a good education, and gives them a spirit of independence and enterprise, that is rarely found amongst the occupiers of small farms and short leases. Their minds being open to conviction, they are ready to try new experiments and adopt every beneficial improvement that can be learned in other districts; for this purpose, many of them have traversed the most distant parts of the kingdom to obtain agricultural knowledge, and have transplanted every practice they thought superior to those they were acquainted with, or that could be advantageously pursued in their own situation, and scarcely a year passes without some of them making extensive agricultural tours, for the sole purpose of examining the modes of culture, of purchasing or hiring the most improved breeds of stock, and seeing the operations of new invented and more useful implements.

5. Implements.

Of the most approved kind; and some of these, as the plough, drill, horse-hoe, &c. owe their chief merits to the improvements of Bailey. A pair of pruning shears recommended as preferable to those in common use for cutting hedges. They consist of a strong sharp knife, six inches long, moving betwixt two square-edged cheeks; the upper handle is two feet six inches long, and the other two feet three inches. (See *Encyclopædia of Gardening*, 2d ed. 1334. fig. 122.)

6. Enclosures.

Size of fields varies with the size of the farms; in some parts from two to six or eight acres; in the northern parts, where the farms are large, from 20 to 100 acres. The quicks should never be planted nearer each other than nine inches, and, upon good land, a foot. Quicks four or five years old, with strong clean stems, are always to be preferred to those that are younger and smaller. It is a custom in some parts to clip young quicks every year: this makes the fence look neat and snug; but it checks their growth, and keeps them always weak in the stem, and, when they grow old, open at bottom; while those that are left to nature get strong stems and side branches, which, by interweaving one with another, make a thick and impenetrable hedge, and if cut at proper intervals (of nine or ten years), will always maintain its superiority over those that have been clipped from their first planting. In point of profit, and of labour saved, there is no comparison; and for beauty, we prefer nature, and think a luxuriant hawthorn, in full bloom, or laden with its ripened fruit, is a more pleasing, enlivening, and gratifying object, than the stiff, formal sameness produced by the shears.

7. Arable Land.

Trench ploughing practised by a few in breaking up grass lands. About 1793, when horses were scarce and dear, a good many oxen were used for ploughing and carting about the farm; but after a few years' trial, they were given up: they were harnessed both with yokes and collars, and only ploughed half a day at a time.

Fallowing on all soils once in three or four years, was general through the county till the introduction of turnips. On soils improper for this root, the naked fallow still prevails; but the quantity of fallow probably on all soils will, after a long series of good culture, become less necessary, and may in many cases be finally dispensed with.

Turnips were first grown in the northern parts of the county about 1723. Proctor, the proprietor of Roch, brought Andrew Willey, a gardener, to cultivate turnips at Roch, for the purpose of feeding cattle; that Willey afterwards settled at Lesbury, as a gardener, and was employed for many years to sow turnips for all the neighbourhood; and his business this way was so great, he was obliged to ride and sow, that he might despatch the greater quantity.

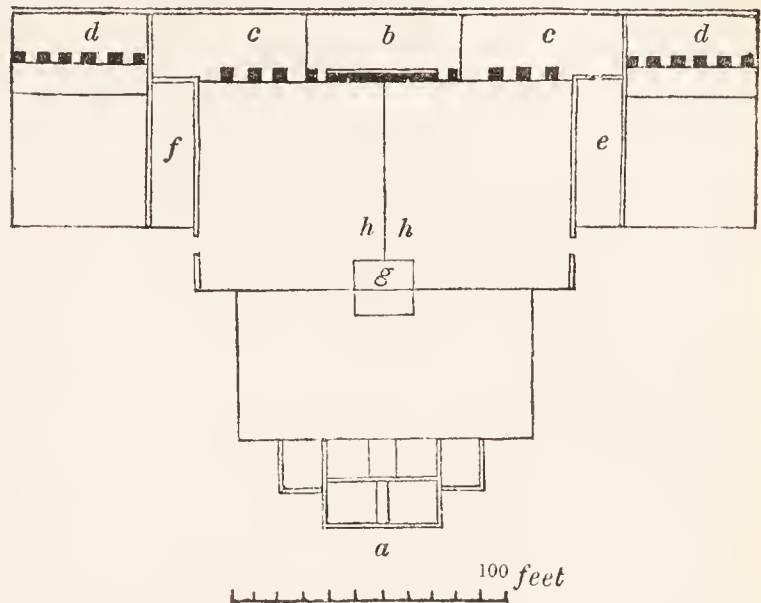
Hoeing turnips was introduced at the same time, and at first practised by gardeners, and other men, at extravagant wages. Ideston, about thirty years since, had the merit of first reducing the price of hoeing, by teaching boys, girls, and women to perform the work equally as well, if not better than men. The mode he took was simple and ingenious: by a light plough, without a mould-board, he divided the field into small squares of equal magnitude, and directed the boys and girls to leave a certain number of plants in each square. In a short time they became accurate, regular, and expert hoers; and, in a few years, all the turnips in the county were hoed by women and boys, at half the expense, and better than by men.

The broadcast culture of turnips, in the northern parts of the county, was not inferior to any we ever saw; and in respect to accurate, regular, clean hoeing, superior to what we ever observed in Norfolk, Suffolk, or other turnip districts which we have frequently examined. (Bailey.)

Drilling turnips was first introduced to the county about 1780. Drilling this, as well as other crops, evidently originated with Tull, whose first work, *Specimen of a Work on Horse-hoeing Husbandry*, appeared in 1731. It appears that Craig, of

Arbigland, in Dumfriesshire, began to drill turnips about 1745; and next we find Philip Howard of Corby drilling in 1755; and Pringle drilling "from hints taken from Tull's book," in

1011



1756 or 1757. William Dawson, who was well acquainted with the turnip culture in England, having been purposely sent to reside in those districts for six or seven years, where the best cultivation was pursued, with an intention, not only of seeing but of making himself master of the manual operations, and of all the minutiae in the practice, was convinced of the superiority of Pringle's mode over every other he had seen, either in Norfolk or elsewhere; and in 1762, when he entered to Frogden farm, near Kelso, in Roxburghshire, he immediately adopted the practice upon a large scale, to the amount of 100 acres yearly. Though none of Pringle's neighbours followed the example, yet, no sooner did Dawson, an actual or rent-paying farmer, adopt the same system, than it was immediately followed, not only by several farmers in his vicinity, but by those very farmers adjoining Pringle, whose crops they had seen, for ten or twelve years, so much superior to their own: the practice in a few years became general.

8. Grass.

Not much old grass in the county.

9. Woods.

Not very numerous, though a considerable demand for small wood by the proprietors of the collieries and lead mines. Artificial plantations rising in every part of the county.

10. Improvements.

Embanking and irrigation practised in a few places which require or admit of these operations.

11. Live Stock.

Cattle the short-horned, long-horned, Devonshire, and wild cattle.

Sheep, the Cheviot, heath, and long woolled. The modern maxims of breeding were introduced into the county by one of Bakewell's first disciples, Culley of South Durham, well known for his work on Live Stock, previous to which, "big bones" and "large size" were looked upon as the principal criterion of excellence, and a sacred adherence to the rule of never breeding within the canonical degree of relationship: but those prejudices are at this period in a great measure done away; and the principal farmers of this district may now be classed amongst the most scientific breeders in the kingdom, who have pursued it with an ardour and unremitting attention that have not failed of success.

Horses for draught brought from Clydesdale.

Goats are kept in small numbers on many parts of the Cheviot hills, not so much as an object of profit, but the shepherd asserts, that the sheep flocks are healthier where a few goats do pasture. This probably may be the case, as it is well known that goats eat some plants with impunity that are deadly poison to other kinds of domestic animals. The chief profit made of these goats is, from their milk being sold to invalids, who come to Wooler in the summer season.

12. Political Economy.

Roads of whin or limestone, and mostly good. Manufactures, gloves at Hexham, plait straw for cottagers' and labourers' hats, and also for those of the higher classes. Woollens in a few places; and a variety of works connected with the coal trade and mines at Newcastle. No agricultural societies, these Bailey holds in little estimation; but thinks if public farms were established in each county, and supported by a rate on the income of its proprietors, they would be the most effectual means of promoting agricultural improvement.

7810. CUMBERLAND. 970,240 acres of mountainous district, remarkable for its picturesque beauty, and also of late greatly improved in its agriculture. The exertions of the late Bishop of Llandaff in planting, and of J. C. Curwen, Esq. in field culture, have contributed much to the improvement of this county, which, as far as its soil and climate permit, may be considered as on a par with Northumberland. (Pringle's *General Review*, 1794. *General View*, by J. Bailey and G. Culley, 1804. *Marshal's Review*, 1808. *Smith's Geological Map*, 1824.)

1. Introductory Observations.

Pringle informs us that "trees and plants, being altogether passive, accommodate themselves very slowly to a change of climate: but the idea has been already thrown out, that even those of the torrid zone may be made to flourish in the northern regions; may be even gradually inured to the climate; that the climate itself may be changed for the better; and that some thousands of years hence, reposing under their own olive trees, future Britons may quaff their own wine, or sip their own tea, sweetened with the juice of their own sugar-cane."

Pringle "found it impossible" not to mention to the Board that he was remarkably well treated when he surveyed the county, which "filled him with peculiar feelings of pleasure and respect." Some of those feelings he voids on Sir John Sinclair, in the following terms:—"What gratitude is due to him (!) who first called the attention of the nation to its most important interests, and whose unremitting efforts are directed to promote the good of his country! How well does he deserve, and what a sure road has he chosen to, immortal fame that will survive the ravages of time, and smile at the fleeting celebrity

of martial achievements!" "This," Marshal observes, "most assuredly means, not *him*, but *me*."

In some preliminary observations to this report by Watson, Bishop of Llandaff, are suggestions for settling poor people in cottages on the wastes, as has been done in Spain, and on the advantages which would result from planting them, especially with the larch and oak.

2. Geographical State and Circumstances.

Climate. Healthy, though subject to great and frequent falls of rain, especially in autumn, which renders harvest late and precarious: snow on the mountains for six or eight months. Average rain at Keswick seventy inches.

Soil. Clays and loams on the better parts of the valleys and hill sides, and peat earth on the mountainous districts.

Surface. Beautifully and greatly diversified, chiefly mountainous, and incapable of being improved by the plough; but part of the valley and plains are cultivatable soils.

Minerals. Chiefly coal, lime, and lead ore; there are also black lead, copper, gypsum, lapis calaminaris, and excellent slate and freestone.

Waters. Sixty-seven miles of sea-coast, several large and small rivers, and the lakes well known for their beauty, and the excellent char, trout, and other fish which some of them produce.

3. Property.

Few counties where land is in such small parcels, and these occupied by their owners. The annual value of these tenements vary from 5*l.* to 50*l.* a year; generally from 15*l.* to 30*l.*, some few 100*l.* Largest estate in the county 15,000*l.* a year. Tenure of by far the greater part of the county "customary tenure," a species of vassalage, by which the holder is subject

7811. WESTMORELAND. 540,160 acres, chiefly of mountain and moor, but with some few tracts of vale lands, cultivated or capable of cultivation. On the whole it is naturally the most unfavourable county to agriculture or comfortable living in England, owing to its wet and cold climate, ungrateful soil, and rugged surface. (*Pringle's General View*, 1794. *Marshal's Review*, 1808. *Smith's Geological Map*, 1824. *Edin. Gaz.* 1827.)

1. Geographical State and Circumstances.

Climate. S. W. winds and rains prevail for eight months in the year: in 1792 eighty-three inches, medium forty-five or fifty inches, which is twenty inches above the medium quantity that falls in Europe. Air pure and healthy; winters long and severe. In 1791-2 thirty-six pounds were paid for cutting in the snow ten miles of horse tract between Shap and Kendal.

The soil most prevalent on the low lands is a dry gravelly mould, and peat on the mountains.

Surface. Mountainous and hilly, and in most places incapable of cultivation by the plough. Large tracts of black barren moors, called the Fells.

Minerals. Some trifling veins of lead; limestone in abundance in most parts of the county; excellent blue slates; gypsum used for laying floors; freestone, and marble near Kendal.

Water. Several rivers and some lakes, corresponding in beauty and products with those of Cumberland.

2. Property.

As in Cumberland; land-owners called statesmen (for estatesmen), as in Ireland.

7812. LANCASHIRE. 1,150,000 acres; (1,155,840, *Brook's Gaz.* 1809, 12,000,000! *Edin. Gaz.* 1827), included in a very irregular outline, extending above a degree, or about seventy-four miles from north to south, containing mountainous and moory surface, and a large portion of low, flat, or moderately varied lands, of good quality. The soil in great part sandy, and chiefly in pasture. The early introduction and successful culture of the potato distinguishes this county, and also the immense extent of its cotton manufactures, and very considerable foreign commerce from Liverpool. It is also the country of Brindley, the engineer. (*Holt's General View*, 1795. *Dickson's General View*, prepared by Stevenson, 1815. *Marshal's Review*, 1808.)

1. Geographical State and Circumstances.

Climate. Air every where pure and salubrious, but on the elevated parts cold and sharp; protected, however, by the northern and eastern ranges of mountains form the N. and E. winds; not much snow or long continued severe frosts. In 1819-20, when the thermometer in gardens near London had fallen ten degrees below zero, that in the botanic garden at Liverpool never fell to zero. Average of rain in the county probably about forty-two inches: in 1792, sixty-five; and in some years fifty. From a register of the times during a series of years, at which potatoes, asparagus, and gooseberries were first brought to the Liverpool market, it appears that the difference between an early and late spring is not less than six weeks.

Soil. On the mountains and moors rocky and peaty; on the northern part of the lowlands moist, cold, and rusky silt; on the rest chiefly sandy loam.

Minerals. Principally coal, copper, lead, and iron; the first and last very abundant; there is also slate, grey-slate, and flagstones, freestone, and limestone.

Waters. Seventy-five miles and upwards of sea-coast, and several rivers and meres.

2. Property.

Very variously divided; a considerable number of yeomanry from 10*l.* to 700*l.* per annum: a general spirit for possessing land and agricultural improvement; tenures, as usual, chiefly freehold.

3. Buildings.

Old farmeries the work of chance and random; houses often there formerly occupied by proprietors, and offices without order or design, but various new erections on the most approved plans; cottages in many places comfortable, with good gardens, especially those occupied by operative manufacturers and mechanics. Those in the less improved parts of walled studd work, plastered or wrought in with tempered clay and straw; provincially "cat and clay."

4. Occupation.

Farms in general small; education and knowledge of most of the small occupiers very circumscribed; larger farmers more enlightened, and having more command of capital, are improving the culture of their farms.

5. Implements.

Little improvement, but the Northumberland plough and Meikle's threshing-machine introduced; horse pattens are

to flines, herlots, and varlots services to the lords of manors. A good deal has been enfranchised. Copyhold and leasehold are rarely met with; what is not customary is freehold.

4. Buildings, Implements, Arable Land, &c.

Approaching to that of Northumberland. A great many young plantations rising on the sides of the mountains.

5. Live Stock.

Cattle of various kinds; breed of the county a small long-horned kind; but the most improved varieties are now introduced.

Sheep bred in the county the Herdwicks, a hardy mountain sheep. Some horses bred by the farmer, and bees very common. In every parish the taking of moles is let at a certain sum, and defrayed by a parochial rate per acre; a plan which will soon eradicate this animal from the county.

6. Improvements

Various kinds, as draining, watering, planting, &c. made by Watson, Bishop of Llandaff, at Colgarth Park. Those of J. C. Curwen, Esq., of Workington, especially in feeding and fattening stock, have made a distinguished figure in agricultural writings; but their practical merits have been questioned. We paid a high compliment to Curwen in the first edition of this Encyclopædia, on which a scientific and practical man, who was personally acquainted with him, made the following note:—"I doubt if Curwen has any right to the compliments here paid him. If I may judge, both from his writings and conversation, he is certainly not a first-rate farmer, and, what in his situation is worse, not very much the friend of farmers. He admitted to me, indeed, that his management was not profitable, which is saying all in one word."

3. Buildings.

Very indifferent; few mere cottages; the labourer and mechanic generally reside in a small farm-house, and occupy more or less land.

4. Occupation.

Farms small; and farmers, who are generally proprietors, "live poorly and labour hard," in the fields in summer, and weaving in winter; wear clogs, the upper part of leather, and the soles of birch, alder, or sycamore. The culture of arable land is very limited, and, like that of grass land, was in a very backward state at the time the reporter wrote, but gradually improving. Dairying in a small way is generally practised, but little attention to the sort of cow or breeding. The Earl of Lonsdale, and Watson, Bishop of Llandaff, were among the first to set the example as to planting.

5. Manufactures.

Woollen cloth, or Kendal coatings, stockings, silk, gunpowder, &c. A private carpet manufactory at Lowther, by the Earl of Lonsdale.

almost peculiar to this county, and are used in cultivating light peaty soils.

6. Arable Land.

Less prevalent than grass; but great attention paid to the culture of potatoes, both by farmers and cottagers; the former generally cultivated in drills, and horse-hoed; the latter in beds or dibbled in rows, and hand-hoed. The method of growing early potatoes, and several crops on the same soil in one season, has already been given. (5521.) Onions are cultivated extensively near Warrington, and rhubarb and madder have been tried, and grown to very great perfection, but not so easily dried and prepared for sale as to induce a continuance of the practice.

7. Grass Lands.

Extensive, but chiefly coarse upland pastures; some good meadows and productive marsh lands. Application chiefly for the dairy for home consumption of milk and butter; not much cheese made, excepting on the Cheshire side of the county.

8. Gardens and Orchards.

Excellent market gardens near most of the large towns. Liverpool remarkably well supplied: great quantities of cabbages and onions used by the shipping, and of dried herbs and onions exported; the dried herbs sent to Africa. "There is a certain farm in Kirkby, about eight miles north-east from Liverpool, the soil of a small part of which is a black loamy sand, and which produces great quantities of early and strong asparagus, and another farm, a part of which is of the same nature at a place called Orrel, about four miles north-west of Liverpool: both which produce this plant with less attention and less dung than requisite in the rich vale of Kirkdale, about two miles from Liverpool, where the greatest quantity of land in any place of this neighbourhood is appropriated solely to horticulture."

Gardens of Mechanics. "A small patch of ground appended to his cottage furnishes the weaver, smith, or carpenter with health and pleasure, and contributes to his sobriety; intemperance not unfrequently proceeding from want of recreation to fill up a vacant hour. This small space is devoted to nurturing his young seedlings, trimming his more matured plants, contemplating new varieties, in expectation of honours through the medium of promised premiums. Thus, starting at intervals from his more toilsome labours, the mechanic finds his stagnating fluids put in motion, and his lungs refreshed with the fragrant breeze, whilst he has been raising new flowers

of the auricula, carnation, polyanthus, or plink, of the most approved qualities in their several kinds; and which, after being raised here, have been dispersed over the whole kingdom. But not only flowers, but fruit, have been objects of their attention. The best gooseberries now under cultivation had their origin in the county of Lancaster; and, to promote this spirit, meetings are annually appointed at different places, at which are public exhibitions of different kinds of flowers and fruits, and premiums adjudged. These meetings are encouraged by master tradesmen and gentlemen of the county, as tending to promote a spirit which may occasionally be diverted into a more important channel. Those little societies for promoting the improved culture of the gooseberry prevail most in the southern parts of the county. They have unquestionably had much influence in bringing the different sorts of this fruit, and the currant, as well as some others, to their present state of improvement. The gooseberry, both of the red and white kind, is now in most places grown to a very considerable size, in some situations as large as a pigeon's egg. This is chiefly effected by keeping the plants much cut in their branches, and having well rotted rich manure applied frequently about their roots, the land being kept perfectly clear about them. The annual publications, called *The Manchester Gooseberry-book*, and *The Manchester Flower-book*, contain the names of the principal societies, and of the prizes awarded each year, and a variety of other information." (*Dickson*, p. 428.)

An orchard of sixty-four acres on the banks of the Irwell, near Manchester, and some others in sheltered places near the principal towns; but the prevailing west winds is much against their increase.

9. Woods and Plantations.

A good deal of planting going forward in most parts of the county, but not much old timber or copse.

10. Improvements.

Of moss bogs and marshes there is great extent, and we have already noticed the principal modes of improving them. (4555.)

A good deal of draining, paring, and burning, and liming has been done, and also irrigation in several places. A good deal of low sod embankment along the northern part of the coast, especially at Rosshall, by Hesketh. It was proposed some years ago to embank Lancaster and Ulverstone sands, by which nearly 40,000 acres of sandy soil would have been gained at an

expense of 150,000*l.*, or according to some much less: but owing to the difficulty of getting the small proprietors of fisheries and other trifling interests to agree, the idea was dropped at the time and not resumed. The proposed modes of procedure for this, and other intended embankments, are given in the report. Bog lands have been extensively cultivated by the celebrated Roscoe, of which some account has been already given. (4549.)

11. Live Stock.

Cattle, the Lancashire, or long-horned, made the basis of Bakewell's improvements; a good many short-horned also bred, when the dairy is the object. Larger grass farms near the populous towns furnish milk, the smaller ones butter, and the remote farms cheese. 100 cows kept in Wakefield's dairy near Liverpool. Cheese made resembles that of Cheshire, and chiefly from the long-horned, or native breed.

Sheep not very common in this district.

Horses very generally bred of the strong team kind, stout compact saddle horses, and middling size and bone for the stage and mail coaches.

12. Political Economy.

Roads bad in most places, owing to the want of good materials, and the moist climate. In the coal tracts about Manchester, Bolton, and Wigan, the roads are all paved, as it was thought no other would stand the heavy traffic on them. These paved roads are said to be the most expensive, and most disagreeable of any; but they have here no other kind of material that will stand heavy cartage.

An ingenious road-maker in the neighbourhood of Warrington has of late exploded the common convex form, and adopted that of one inclined plane; the inclination just sufficient to throw off occasional water. The road between Worsley and Chowbeats was made in this form, but it was found not to answer, as, though it threw off the water, high and heavy laden waggons were exposed to much danger of being overturned.

Various canals and iron railways; those of the Earl of Bridgewater the most celebrated, but others of recent date more extensive. Many different manufactures; cotton in its different branches the most important; also, woollen, flax, iron, and, in short, almost as great a variety as in Derbyshire. Several agricultural societies; that of Manchester established in 1767.

7813. The ISLE OF MAN contains about 220 square miles. (*Edin. Gaz.* 1827.)

General View. The interior is mountainous, ridges of hills being separated by high table lands; the climate is moist, with frequent fogs; and the soil is chiefly loam, on a bottom of stiff clay. No minerals of any consequence are found on the island, except lead, and some copper, and iron. Limestone, thin blue slate, greywacke, and granite are found in several places; an immense tract called the Curragh, which was formerly a bog, extends nearly across the island. It now produces excellent crops; but an extensive stratum of peat is still found under the gravel and clay, containing trunks of very large oaks and pines, which all lie in one direction, as if overturned or deposited by a common impulse.

The Duke of Athol was formerly lord proprietor of the whole island, but the sovereignty was purchased from him by the English government, 1765.

Agriculture has of late years made some progress, though nearly two thirds of the island still remain in a state of nature, and are only used for grazing; there is a good deal of wood in

the north part of the island; wheat was formerly not cultivated on account of a prejudice which prevailed respecting its liability to be infected with the smut; large crops are, however, now raised, of the cleanest and best quality. Barley and oats are raised in great quantities, as are also turnips and potatoes. Flax and hemp are grown in rich enclosures. Many of the finer sorts of fruit, however, cannot be reared. The sheep are small and hardy, and their flesh is excellent; the wool of a particular breed, called the Loughton, is thought of a very superior quality. Great numbers of cattle are fattened here for exportation; and 50,000 hogsheads of butter are sent to England annually. Poultry, eggs, and fish, are abundant and cheap. Thin oatcakes are the usual bread of the inhabitants.

Political Economy. The roads to the principal towns are tolerably good, but the by-ways are almost impassable. The island is considered healthy, and the inhabitants generally attain a great age.

7814. CHESHIRE. 665,600 acres of verdant surface, exclusive of upwards of 10,000 acres of naked sands in the estuary of the river Dee. It is one of the most productive grass-land districts in the kingdom, the grass retaining its growth and verdure, in a great degree, during the whole year, owing to the moisture and mildness of the climate. The department of husbandry in which it excels is cheese-making; and it is also noted for its salt-works from brine springs and rock. (*Medges' General View*, 1794. *Holland's General View*, 1806. *Marshal's Review*, 1809.)

1. Geographical State and Circumstances.

Climate, supposed the most rainy in the kingdom.

General surface an extended plane, apparently thickly covered with wood. Barren hills on the eastern margin of the county.

Soils chiefly clayey or sandy; clay prevails, but very generally the two earths blended together, producing clayey loam and sandy loam.

Subsoil chiefly clay, or marl; but also rammel, foxbench, gravel, or red rock. Rammel is a composition of clay, sand, gravel, and oxide of iron; it is in strata of from eighteen to thirty inches, on white-coloured sand, or clay marl. Foxbench is iron ore or oxide, which crumbles to pieces when exposed to the air; but is hard and rocky when under the soil, and is more injurious to trees than rammel, as it cannot be penetrated by their roots.

Minerals. Fossil salt and coal both extensively worked. There is also copper, lead, and freestone, but very little limestone. Salt is made from brine springs, as at Droitwich (7792.), and from beds of fossil salt. The former have been worked from time immemorial, and the latter from about 1670. By the operation of blasting, and the mechanical instruments usually employed in mining, the rock is obtained in masses of considerable size, differing in form and purity. The purer rock is pounded and used without other preparation; but the less pure is dissolved and refined in the same manner as brine.

Water. Several rivers and meres; the former are very muddy after rains, and not remarkable for their fish; but the latter abound in pike, bream, perch, dace, and eels.

2. Property.

Few counties of equal extent with so many wealthy landowners. Fifty proprietors resident in the county, with estates of from three to 10,000*l.* a year, and as many from one to 5000*l.* "From the advantages which have been derived from trade, and from the effects of the increase of taxes, which have prevented a man living with the same degree of comfort on the same portion of land he could formerly, many of the old owners have been induced to sell their estates, and new proprietors have spread themselves over the country, very different in their habits and prejudices. It may be doubtful whether the change on the whole has been disadvantageous. Land, when transferred, is generally improved by its new possessor. With

a view, and often a more enlightened view, of its advantages and resources, he brings with him the means and the disposition to try experiments, and to give to his new acquisition its greatest value. He feels the want of comforts and conveniences, which custom had rendered familiar to a former occupier; he builds, drains, and plants; and, by his spirit and example, stimulates all around him to increased exertions.

3. Buildings.

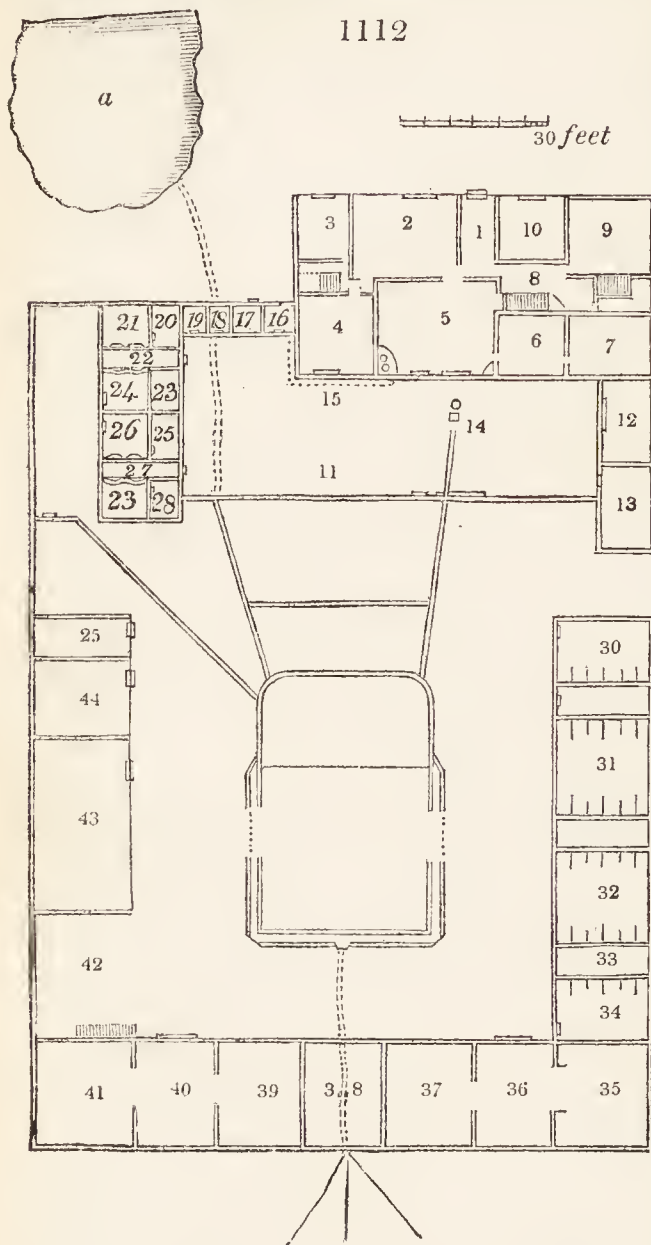
Many noble mansions, especially that of the Earl Grosvenor, at Eaton.

Farm buildings, on the large dairy farms, in the middle of the county, extensive and convenient; in other places the reverse, and crowded in villages; old buildings of shed-work, wattled work, and clay, and covered with thatch; new of brick and slate. An excellent set of buildings (*fig.* 1112.) has been erected at Bromfield, near Warrington, on the estate of Sir P. Warburton. "A gentle descent from the ground at the front of the house has afforded Beckett, the occupier of this farm, the opportunity of conveying from a pond (a) a small stream through the farm-yard, with which he irrigates the meadows below the buildings. The superior richness of vegetation in these meadows furnishes abundant proof of the advantage which Beckett derives from availing himself of this assistance."

Beginning with the *dwelling-house* of this farmery, it contains an entrance and passage (1), house-place (2), servants, dining-room (3), back parlour (4), dairy, with whey pans and sink-stone (5), room for the cheese after it is taken out of the salt (6), milking-house and salting-room (7), stairs to cheese-room (8), parlour with a cellar under (9), pantry (10). The immediate appendages of the house chiefly connected with the dairy are ranged on three sides of the inner yard (11), and consist of a coal-house (12), wash-house, with pigeon-house over it (13), pump (14), pipe to boiling-pans (15), boiler for pig meat (16), privy (17), place for ashes (18), privy (19), inner pig-cot (20), outer pig-cot (21), passage (22), inner pig-cot (23), outer pig-cot (24), inner pig-cot (25), outer pig-cot (26), passage (27), inner pig-cot (28), outer pig-cot (29).

The *furmyard* consists of a court, containing a large duck-pond and dunghill, surrounded by a broad passage, and enclosed on the west, east, and south sides by buildings, the north side being the wall of the inner yard. These buildings

consist of a cow-house (30), double cow-house (51), double cow-house (32), fodder-bin (33), cow-house (34), corn-bag (35), threshing-floor (36), corn-bag (37), corn-bag (38), corn-bag (39), threshing-floor (40), corn-bag (41), cart-hovel, with granary above it (42), stable (43), stable or calf-cot (44), calf-cot (45).



Cottages much the same as in other counties; improving with the age. All the intelligent persons whom Dr. Holland conversed with have invariably found, that the attachment of a small portion of land to the cottage of the labourer has been the direct means of rendering his situation in life more comfortable and easy, and of inducing those habits of honest independence, of temperance, and of industry, which are most efficacious in promoting the happiness of individuals, and, consequently, the general interests of society.

Lord Penrhyn's poultry-houses, at Winnington, are supposed the most magnificent that have ever been built. They are united in a building, which consists of a handsome regular front, extending about 140 feet: at each extremity is a neat pavilion, with a large arched window. These pavilions are united to the centre of the design by a colonnade of small cast-iron pillars, painted white, which support a cornice and a slate roof, covering a paved walk and a variety of different conveniences for the poultry, for keeping eggs, corn, &c. The doors into these are all of lattice-work, also painted white, and the framing green. In the middle of the front are four handsome stone columns, and four pilasters, supporting likewise a cornice and a slate roof, under which and between the columns is a beautiful mosaic iron gate; on one side of this gate is an elegant little parlour, beautifully papered and furnished; and at the other end of the colonnade a very neat kitchen, so excessively clean, and in such high order, that it is delightful to view it. This front is the diameter or chord of a large semi-circular court behind, round which there is also a colonnade, and a great variety of conveniences for the poultry: this court is neatly paved, and has a circular pond and pump in the middle of it. The whole fronts towards a rich little field or paddock, called the poultry paddock, in which the poultry have liberty to walk about between meals. It happened while the reporter was there to be their dinner-time, at one o'clock. At this hour a bell rings, and the beautiful gate in the centre is opened. The poultry being then mostly walking in the paddock, and knowing by the sound of the bell that their repast is ready for them, fly and run from all corners, and rush in at the gate, every one striving who can get the first share in the scramble. At that time there were about 600 poultry of different kinds in the place, and although so large a number, the semi-circular court is kept so very neat and clean, that not a speck of dung is to be seen. This poultry place is built of brick, excepting the pillars and cornices, and the lintels and jambs of the doors and windows, but the bricks are not seen, being all covered with a remarkably fine kind of slate from his lordship's estate in Wales. These slates are closely jointed and fastened with screw

nails, on small spars fixed to the brick; they are afterwards painted, and fine white sand thrown on while the paint is wet, which gives the whole an appearance of the most beautiful freestone.

4. Occupation.

Farms very small; a great many under ten acres; only one or two at 350 or 400 acres; excluding all those under ten acres, the average of the county may be seventy acres. Large and small farmers completely different characters;—different in their habits, and, by consequence, in their ideas. Industry and excellent management of the dairy-women of this county much to be commended; leases generally for seven years.

5. Implements.

Rotherham plough and other good implements. A short strong scythe, with a blade twenty inches in length, and concave in the middle, is used for scooping out the crowns of rush stools.

6. Arable Lands.

In small proportion to the pastures. Cabbages a good deal cultivated for cattle. Carrots near Altringham for the Manchester market, and also seed for the London seedsmen. Onions also for the Lancashire markets. The soil about Altringham dry and loamy; the carrots large, coarse, and fit only for horses and cattle.

7. Grass.

Natural meadows numerous, rich, and fertile. They are situated on rivers, which, from the frequency of heavy rains, overflow and enrich them. Extent of upland pasture very considerable; that on a tolerably stiff clay soil, especially with a substratum of marl, is reckoned the best for the dairy; more milk may be had from cows pastured on a rich loamy soil, but it is esteemed inferior in point of quality. Many farmers complain that their land is too rich for the dairy, by which the adhesive properties of the cheese is diminished: feeding of cattle little practised.

8. Gardens and Orchards.

Good gardens to most of the farm-houses. "All the varieties of raspberries, currants, strawberries, and gooseberries are to be met with in the farm and cottage gardens in Cheshire. The culture of the latter fruit has been particularly attended to of late years; and there are several meetings in different parts of the county, where small premiums are adjudged to those who produce, out of their own gardens, gooseberries of the greatest weight. The common fruit trees, such as the apple, pear, cherry, and plum, are likewise grown in almost every garden. Of the latter kind, the damascene plum is by much the most common; and is an article of considerable profit to the cottager.

Orchards not numerous, and rather on the decline.

9. Woods and Plantations.

Few of large extent, yet the quantity of timber very greatly exceeds what would be a fair average for the kingdom at large. In the northern and middle parts the number of trees in the hedge-rows and coppices is so considerable, that, from some points of view, the whole county has the appearance of an extensive forest. The most considerable ancient woods in the Earl of Stamford's park at Durham Massey. Few spots can boast such an assemblage of stately oaks, elms, and beeches. During a storm of wind, on the 21st of January, 1802, several hundred trees were torn up by the roots. One of these, when barked, contained 403 feet of timber, and was sold at six shillings and sixpence per foot, to the extent of 375½ feet. An elm blown down at the same time measured 146 feet. A colony of herons had for ages fixed their residence on the summits of these trees; but on one of them being torn up, they retreated to a neighbouring grove of beeches, where they have ever since enjoyed a secure abode.

A plantation of 1000 acres at Taxall, F. Jodrell, Esq.; it was planted by White, the landscape gardener of Woodlands, Durham, at five pounds per acre, half the trees to be firs. Extensive plantations by Ashton, on Delamore forest.

Whiteley, an ingenious tanner, at Ashley, near Knutsford, made some experiments a few years ago with the twigs and ends of the boughs of oak, as a substitute for the bark. These ground down, and used in the same way as the bark, manifested strongly astringent properties: but the necessity there was found to be for their immediate application took away very greatly from their value; and their use is now almost entirely discontinued, though the plan at that time was adopted by several other tanners.

10. Improvements.

Draining a good deal practised, especially with bricks and stones. Paring and burning, marling, sanding, claying, and liming, also practised to different degrees of extent. Sand of advantage, chiefly by altering the texture of the soil, as that used contains no calcareous matter.

11. Live Stock.

Present stock of dairy cows a mixture of the long and short horned, the Derbyshire, Shropshire, Staffordshire, Welsh, Irish, Scotch, and New Leicestershire cattle. Those cows reckoned best which are bred on the farm. Calves reared from the best milkers, and at two years old put to the bull. Cows housed about the middle of November; permitted to go dry ten weeks before their time of calving: usual dry foods, wheat, barley, and oat straw, hay, and crushed oats. The two former kinds of straw are found to make cows go dry much sooner than the latter; and another generally allowed effect attributed to such straw is, that more than the usual time will be required to churn the cream of cows when so fed; but wheat straw is esteemed much more wholesome than barley straw, as having less of those effects attending it. Three or four weeks before calving, hay given; and from calving to turning to grass, some ground or crushed oats twice a day. The cows are turned into an outlet (a bare pasture field near the buildings), about ten o'clock in the morning, and housed again about four in the afternoon the winter through, or earlier if they showed an inclination to return; but have no fodder in the outlet. Turning the cows out to grass in good condition is a matter much attended to, in order that they may, as the term is, "start well;" for if a cow is not in good condition when turned out to grass, or has been too much dried with barley straw, it is a long time before she gets into full milk.

The ox-cabbage and Swedish turnip are the kinds of green food most esteemed and cultivated in Cheshire. The former is

usually given to the cows when the after-grass is consumed; it is sometimes given in the spring to cows that have newly calved. The large sugar-loaf cabbage has been occasionally used, when the pastures begin to fail and the after-grass is not ready; a circumstance which frequently happens, especially in dry weather. Turnips are given to the cattle in the winter, while they are feeding on straw; and as, at this time, no cheese is made, any objection to their use, from the flavour they give to the milk, is of little consequence. The reporter made enquiries from several farmers, with a view of ascertaining whether the stall-feeding of their milch cows might not be continued during the whole year, but he found the general opinion to be against this practice; though it did not appear that any experiments, sufficient for the decision of the point, had hitherto been made. It was suggested to him, however, that it would be an improvement upon the present management, to let the cows stand in their houses during the heat of the day in summer, where, by giving them a few cabbages or tares, the milk would continue forming, and the cattle be defended from the gad-fly, which, by tormenting them in the fields, frequently injures both the quantity and quality of the milk.

Time of calving March and April. At calving-time the cowman, or the master, are frequently up two or three times in the course of a night, to see whether any thing is amiss. The racks and mangers are every day well cleaned out, while due attention is paid to the appetites of the different beasts, and the quantity of food is governed accordingly. After this is done, the master himself generally goes round from stall to stall just before bed-time, and adds to or diminishes the quantity of fodder as occasion may require.

In making butter the whole of the milk and cream is churned together. Cheese made from the whey pressed from the curd used in making cheese.

Cheese-making has remained stationary in Cheshire for many years; best size of cheeses sixty pounds. Cows milked during summer at six o'clock, morning and evening. "The evening's milk (of suppose twenty cows) having stood all the night in the coolers and brass pans, the cheese-maker, in summer about six o'clock in the morning, carefully skims off the cream from the whole of it, observing first to take off all the froth and bubbles, which may amount to about a pint: this not being thought proper to be put into the cheese, goes to the cream mug to be churned for butter, and the rest of the cream is put into a brass pan. While the dairy-woman is thus employed, the servants are milking the cows, having previously lighted a fire under the furnace, which is half full of water. As soon as the night's milk is skimmed, it is all carried into the cheese tub, except about three fourths of a brass pan full (three or four gallons), which is immediately placed in the furnace of hot water in the pan, and is made scalding hot; the half of the milk thus heated in the pan is poured also into the cheese-tub, and the other half is added to the cream, which, as before observed, was skimmed into another brass pan. By this means all the cream is liquified and dissolved, so as apparently to form one homogeneous or uniform fluid, and in that state it is poured into the cheese-tub. But before this is done, several bowls or vessels full of new milk will generally have been poured into the cheese-tub, or perhaps the whole morning's milk. Care is taken to skim off all the air bubbles which may have formed, in pouring the new milk into the cheese-tub. The night and morning's milk, and melted cream, being thus

all put into the cheese-tub, it is then ready to receive the rennet and colouring, or, in the terms of the art, to be set together. The rennet and colouring being put into the tub, the whole is well stirred together, a wooden cover is put over the tub, and over that is thrown a lincn cloth. The usual time of coming is one hour and a half, during which time it is frequently to be examined: if the cream rises to the surface before the coming takes place, as it often does, the whole must be stirred together so as to mix again the milk and cream, and this as often as it rises, until the coagulation commences. A few smart strokes on different sides of the tub, with the cheese ladder, &c. will forward the coagulation, if it is found to be too long in forming.

The curd is in the next place broke by the knife and hands, and then left half an hour to subside; then it is gently pressed, the curd broken by the hand, and the whey ladled out of the tub as it drains from the curd. Afterwards, the curd is broken in a brass pan and salted, and next put into the cheese-vat, and pressed with a sixty pound weight, till all the whey is removed. It is then again broke, washed with warm whey, and finally put in the press under a weight or power of about 14 cwt. After being forty-eight hours in the press, it is put in the salting tub, where it remains three days covered with salt; it is then taken out and placed on the salting benches, where it is turned once a day; it is then washed in warm water with a brush, and wiped dry with a cloth; in two hours it is smeared over with whey butter, and then put in the warmest part of the cheese-room. In the cheese-room it is well rubbed, to take off the sweat or fermentation which takes place in cheese for a certain time after it is made, and turned daily for seven days, and smeared with whey butter; afterwards it is turned daily, and rubbed three times a week in summer, and twice in winter.

The cheese-rooms are commonly placed over the cow-houses; and this is done with a view to obtain that moderate and necessary degree of temperature so essential to the ripening of cheese, to which the heat arising from the cattle underneath is supposed very much to contribute. On dairy farms, one woman servant is kept to every ten cows; these women are employed in winter in carding, spinning, and other house-wifery business; but in milking, the women, both night and morning, during summer, where large dairies are kept, are assisted by all the other servants, men and boys, except the man who drives the team.

Sheep little attended to in Cheshire.

Horses brought from Derbyshire and Leicestershire.

Hogs, a mixture of long and short eared breeds.

Poultry of the common kind abundant in most farms for their eggs. Geese kept by the cottagers till midsummer or later, and then sold to the farmers, who fatten them on their stubbles.

Bees to be found at many of the farm-houses, and at some of the cottages.

12. Political Economy.

Roads bad; various canals; an extensive commerce of coal and salt, and manufactures of silk, woollen, linen, and cotton. An experimental farm established at Waverham, near Northwich, by some gentlemen and farmers of the neighbourhood, but it was soon found so expensive and losing a concern as to be abandoned. Those on the plan suggested by Bailey (7809.) seem the most likely to be effective and permanent.

7815. HAMPSHIRE. A maritime county, which includes also the Isle of Wight: the latter contains 94,600 acres, and the continental part of the county 968,150 acres. The climate of this county being remarkably mild, and the soil in many places being calcareous, and consequently warm, very early arable crops are produced in some places, and peas grown better than in many districts. The culture of the county, however, has little to recommend it, either in its tillage or pasturage. Its woods are extensive. (*A. and W. Driver's General View*, 1794. *Vancouver's General View*, 1808. *Warner's Isle of Wight*, 1794. *Marshal's Review*, 1817.)

1. Geographical State and Circumstances.

Climate generally mild.

Soil in the central parts a strong flinty calcareous loam: in other parts generally gravelly, or sandy and calcareous. The soil of the Isle of Wight is partly a clayey and calcareous loam, and in part lighter.

Minerals: none of any consequence; potter's clay, sand, and building-stone in different places.

Water scarce in dry seasons in the chalk districts, where it is preserved in tanks, and drawn up from wells 300 or 400 feet deep. In some parishes, after a long dry autumn, there has been more strong beer than water. A good deal of fishing on the coast; of eels after floods in the smaller streams; and some fish ponds on Bagshot Heath.

2. Property.

Largest estates on the chalky districts; largest 8000*l.* per annum. Great bulk of the lands held and cultivated by yeomanry; tenures, copyhold and leasehold, from the superior lords or freeholders.

3. Buildings.

Houses of proprietors numerous: farm-houses mostly of great antiquity; those of the larger kind were formerly grange or manor-houses; out-buildings numerous, and generally ruinous; cottages often of mud (*provin. cot*) walls, but better on the whole than in some other counties. Some fanciful rustic structures as shelters or temporary lodges for cattle, in the forest district. (fig. 1113.)

4. Occupation.

Farms various, rather small.

5. Implements.

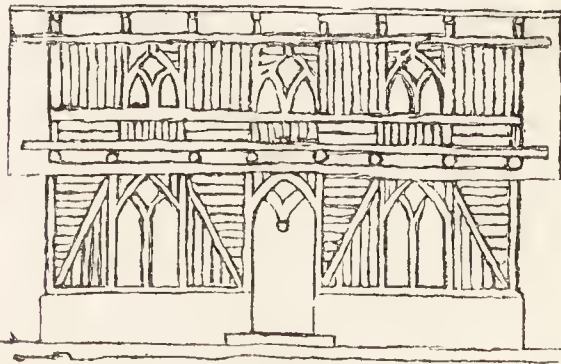
Hampshire plough, an extraordinary bulky clumsy structure; the Suffolk plough is used in the southern parts of the county, and in the Isle of Wight. The patent Hampshire waggon is formed by uniting two carts, corresponding with the fore and hind parts of a waggon, by bolting them together. The thrill of the hind part passes under the bed, and rests on the pillow of the fore-cart. The union is simple, yet so complete as to render this waggon as strong as the common kind, if not stronger.

6. Arable Land.

Tillage difficult and expensive in the chalk district, light and easy in the vale of Avon. Peas a good deal cultivated on

the chalks, especially the Marlborough grey or partridge, the charlton and pearl; in warm situations they are drilled and often sown before Christmas, or in January. "A considerable

1113



mystery still seems to hang over certain properties of these peas, with regard to their boiling well for soup or porridge; good boilers being sometimes sown upon fields which have never been known to refuse yielding a produce possessing a similar quality, but that effect afterwards ceasing, and a hard indissoluble pea has been produced that continued for several successive periods; whilst, on the other hand, land that had never been known or even suspected of being able to communicate a boiling quality to its peas, would unexpectedly give to the produce of a hard and almost impenetrable pea all the properties of being excellent boilers. Through all the cedar-coloured sand and gravelly loams in Devonshire, good boilers are stated to be uniformly produced, and in continued succession. The same kind of soil, and in every respect under similar circumstances, in the Isle of Wight will only occasionally, and by accident as it were, produce good boiling peas. Some opinions seem to refer this effect to a peculiarity in the seasons; but this cannot stand against a well known truth, that good boilers are produced every season."

Saintfoin cultivated with success on the chalky soils, and very productive. Hops on the borders of Surrey. A vineyard was planted at Undercliff, in the Isle of Wight, by the late Sir Richard Worsley, in 1792, and an Anjou vine-dresser brought over to attend it; the extent was about two and a half acres, and a light wine was made; but in 1808, when M. Vancouver called to see it, he found the vines had been grubbed up, and the ground changed to a lawn of turf.

7. Grass Lands.

The county famous for water meadows, which are well managed, and productive; they are chiefly in the neighbourhood of Winchester, on the Itchen; but there are instances on most of the other rivers and streams.

8. Gardens and Orchards.

Excellent market gardens near Gosport and Portsmouth; Portsea island noted for its broccoli; white-washed mud walls, with copings of thatch used as fences, and for wall fruit in some cases; and fruit walls only half a brick thick, and waving at the rate of one foot in twenty in use. In other cases angular walls are in use, the angles being right angles, and the sides ten feet each. The advantage in both cases is the saving of bricks; but it is evident they cannot be carried very high, nor, subject as they are to the driving and drawing of nails, can they be of great duration. (See *Encyclopædia of Gardening*, 1567.)

Orchards in various places, and cider made both in the county and in the Isle of Wight.

9. Woods and Plantations.

Extensive beechwoods on the chalk district, those of Ditcham grove very fine; elm scarce in the county, but abundant in Strathfieldsay Park (now the Duke of Wellington's). Oak abundant in the New Forest district, and many young plantations there, and throughout the county. Cobbett raised a great many American trees of various species at Botley. There are several considerable forests, viz. the New Forest, Alice Holt, Woolmer, and Bere.

The New Forest is situated on the south side of Hampshire; it was formerly bounded on the east by Southampton river, and on the south by the British Channel, being near thirty miles in length, and ninety in circumference; but, since the disafforestations by Henry the Third and Edward the First, its boundaries are much reduced, and now only extend from Gadshill, on the north west, to the sea, on the south-east, about twenty miles; and from Hardley, on the east, to Kingwood, on the west, about fifteen miles; containing within those limits about 92,365 acres, the whole of which does not now belong to the crown, as several manors and freehold estates, to the amount of 24,797 acres, are private property; about 625 acres are copyhold, belonging to His Majesty's manor of Lyndhurst; 1004 acres are leasehold, held under the crown; 902 acres are encroachments; 1195 acres are held by the master-keepers and groom keepers, attached to their respective lodges; and the remaining 63,844 acres are the woods and waste lands of the forest. The other forests are of much less extent and interest.

10. Improvements.

Good examples of draining by tapping were exhibited by Elkington, on Cadland Park estate: the strata lying at a small angle with the horizon, enabled the principles of what is called Elkington's mode of draining to be carried completely into effect. In the eastern part of the Isle of Wight are various tracts of marshy ground, the largest of which, Brading Haven, containing about 900 acres, was granted by James I. to one Gibbs, a groom of the bed-chamber. The owners of the adjoining lands contested this grant, which the king was very

7816. WILTSHIRE. 870,000 acres of varied surface, partly chalky downs, and partly rich vale land; and both a corn and grass county. It produces excellent cheese and butter, fat cattle, pigs, and store sheep. The agricultural report of this county was drawn up by T. Davis, steward to the Marquess of Bath, at Longcat, a man of great experience as a land steward, surveyor, and farmer, and universally respected. He divides the county into two districts, the south-east and north-west; a very judicious plan for giving correct agricultural information. (*Davis's Wiltshire*, 1794. *Marshal's Review*, 1809. *Edin. Gaz.* 1829.)

7817. SOUTH WILTSHIRE.

Wiltshire downs contain about 500,000 acres of hilly surface, mostly unenclosed and in common pasture; the atmosphere cold and sharp, with a chalky soil, seldom varied by patches of loam, sand, or other earths. There is scarcely a river or brook in this district that is not applied in some way or other to the purposes of irrigation.

1. Property.

Near large towns property is generally subdivided when sold; in this district, when any is sold it is generally bought up by such as are considerable proprietors: hence estates generally large. Shape of the manors shows that many of them were the property of one lord; each borders on or contains a rivulet to supply water and the accompaniment of rivulets in that district, meadow land, with hill for wood; or, where these were wanting, they were supplied by a grant of those articles from other property. Proprietors generally resident on their estates.

2. Buildings.

Farm-houses generally crowded together in villages, for convenience of water. Some of late years erected central to their farms, by the Earl of Pembroke, and other proprietors; wells and ponds an important article in these erections.

3. Occupation.

Farms of two kinds; those in severalty, or not subject to rights of common, are from 150*l.* to 500*l.*, and one or two at 1000*l.* a year; customary tenements, subject to rights of common, are from 25*l.* to 40*l.* or 50*l.* per annum. There are extensive sheep commons and cow commons, to which the occupiers of both descriptions of lands have a right to turn in stock, according to certain fixed and customary regulations. Leases seven, fourteen, or twenty-one years.

4. Implements.

A heavy two-wheel and one-wheel plough in use; the latter sometimes with a foot instead of a wheel.

5. Arable Land.

An old error exists, that of over-pulverising the uplands by too frequent ploughings, by which the wheats were thrown out during winter, or if they stood the winter, the March winds blew away the earth from their roots, and "hanging by one leg," and thus not receiving any assistance from the coronal root, the plants are weak in straw, and produce small thin ears. "Many

earnest in supporting. After a verdict obtained in the Court of Exchequer against the gentlemen of the island, Gibbs sold his share for 2000*l.* to Sir Bois Thelwall, a page of the king's bed-chamber, who admitted the famous Sir Hugh Middleton to a share. They employed a number of Dutchmen to enclose and recover the haven from the sea. The first taking of it in cost 4000*l.* and 1000*l.* more was expended in building a dwelling-house, barn, water-mill, trenching, quicksetting, and other necessary works; so that, including the original purchase, the total expenditure amounted to 7000*l.* But after all, the value of the ground did not answer the expectations of the undertakers; for though that part of it adjoining Brading proved tolerably good, nearly one half of it was found to be a light running sand; nevertheless, an incontestable evidence appeared, by the discovery of a well, cased with stone, near the middle of the haven, that it had formerly been good ground. Sir Hugh Middleton tried a variety of experiments on the land which had been taken in, before he sold his share; sowing it with wheat, barley, oats, cabbage, and finally with rapeseed, which last was alone successful: but the greatest discouragement was, that the sea brought up so much ouze, weeds, and sand, which choked up the passage for the discharge of the fresh water. At length, in a wet season, when the inner part of the haven was full of fresh water, and a high spring tide, the waters met under the bank, and made a breach. Thus ended this expensive project; and though Sir John Oglander, who lived in the neighbourhood, confessed himself a friend to the undertaking, which, besides its principal object, tended to render that part of the country more healthy, he declared it as his opinion, that the scheme could never be resumed to any profitable purpose.

11. Live Stock.

No exclusive breed of cattle. The Sussex, Suffolk, Leicester, Hereford, Devon, &c. are indiscriminately met with. Several ox teams.

Sheep. In the Woodland district the heath sheep, old Hampshire, or Wilts breeds, but most of the improved breeds also to be met with.

The horses used in teams generally large, heavy, inactive animals. Small horses bred in vast numbers upon the heaths and forests, and which have not improperly acquired the name of heath croppers. Their ordinary height is about twelve hands. They propagate indiscriminately upon these wastes, where they seek their living throughout the year, and at four years old may generally be purchased at above five pounds.

The native hog of this county is a coarse, raw-boned, flat-sided animal, agreeing in no respect with the idea entertained of it in other parts of the kingdom. The great number fed for a few weeks in the close of autumn, upon the acorns and mast which the forests and other woodlands produce, in the county, and the excellent mode of curing hog-meat practised by the house-keepers, have contributed in a far greater degree to establish that superiority ascribed to Hampshire bacon, than any inherent excellence in its native breed of hogs. Very few, however, of the genuine native hog are to be met with, the common stock being either the native Berkshire breed, or a considerable predominance of that blood in the native swine of the county.

12. Political Economy.

Roads in general good, especially in the New Forest. Several canals, and various manufactures and public works at Portsmouth and other places. The machinery for making blocks (1850) is reckoned the most ingenious and complete of its kind in the kingdom.

modes have been introduced to prevent this evil, by giving a sufficient texture and firmness to the land previous to a wheat crop. The best farmers have made a point of getting their lands clean ploughed by midsummer, and treading it as firm as possible with the sheep-fold a long time before sowing; while the slovenly farmers have invented, and generally practise, a very short and cheap way of attaining this firmness in the land. They rafter the land (as they call it), that is, they plough half of the land, and turn the grass side of the ploughed furrow on the land that is left unploughed. They do this as soon as they can spare the feed of the summer-field, and leave it in that state till near seed-time, when they harrow it down and plough it for sowing. This rafter is usually ploughed across the ridges, or what is better, diagonally; the latter mode being less subject to drive the land up in heaps before the plough. The land thus rafted is sometimes ploughed twice, but more frequently only once, previous to sowing; and after it is sown they drag it two, three, or four times, and harrow it four, five, or six times. A very heavy kind of drag is used; and as Wiltshire Down farmers are very cautious of ploughing their land too much, they make much use of these drags instead of ploughing, and frequently let in their seed-wheat with them. This practice having been found to answer, has been gradually improved upon. The down lands of this district will not bear fallowing, especially in hot dry weather; they are too thin and light already, and require rest. Two years' rest for wheat is equal to the best coat of dung. Dung may give the quantity, but rest must give the quality.

The course of crops was formerly fallow, wheat, barley, oats; but now, even on the common fields, is wheat, barley, clover, mowed one year, and fed two years, till it is necessary to plough for wheat. Turnips, Swedes, and rape grown for winter food for sheep, though less necessary than in districts less amply provided with water meadows. Error that of sowing too much corn.

Gardens near Devizes, Lavington, Warminster, Westbury, &c. Many families subsist by this kind of husbandry, occupying from two to five acres each as garden ground. The produce supplies the adjacent towns in the district, and Frome and Bath, in the county of Somerset, with cabbage-plants, peas, beans, carrots, turnips, and vast quantities of potatoes.

Orchards in some places, and cider made; but as the district

is famous for its barley and ale, the predilection for this beverage renders the want of cider little felt.

Woods not numerous, but a great spirit for forming plantations; and some excellent remarks on the subject in the Report.

Irrigation introduced into this district the end of the seventeenth, or the beginning of the eighteenth century. Many of the most valuable and best-farmed meadows, particularly those in the Wyley Bourne, were made under the directions of one Farmer Baverstock of Stockton, between the years 1700 and 1705.

Between 15,000 and 20,000 acres watered; its great value in April between "hay and grass," by which the farmer is enabled to breed early lambs. As soon as the lambs are able to travel with the ewes (perhaps about the middle of March), the flock is put into the water-meadows. Care is, or ought to be, taken to make them as dry as possible for some days before the sheep begin to feed them; and on account of the quickness of the grass, it is not usual to allow the ewes and lambs to go into them with empty bellies, nor before the morning dew is gone. The general hours of feeding are from ten or eleven in the morning, till four or five in the evening, when the sheep are driven to the fold, which at that time of the year is generally in the barley fallow. The grass is daily hurdled out in portions, according to the number of sheep, to prevent their trampling it down; but a few spaces are left in the hurdles for the lambs to get through and feed forward in the rich grass. One acre of good grass will be sufficient for 500 couples for a day: the great object is to make the water-grass last till the barley sowing is finished; the meadow is then laid up for hay.

The water-meadows of Orcheston, a village six miles N. W. of Amesbury, have been long celebrated. What is called the long grass of these meadows is said by Davis to be the *Agróstis stolonifera*, or black couch; but this has been subsequently ascertained to be a mistake. The grasses which compose these meadows were examined by Thomas Tanner, a scientific botanist, in 1811, and reported on in the *Farmer's Magazine*, vol. xiv. p. 129; and the following very interesting extract deserves the attention and reflection of the farmer, for other reasons besides its botanical information. It appears probable from it that deep dry soil, which will admit the roots of saintfoin and other long-rooted herbage plants, may, one year with another, yield as much nutriment as rich irrigated surfaces, and probably at much the same expense:—"Much has been said of the excellent quality of the hay, when well made; that, for instance, it will fatten pigs; and that it abounds with the saccharine quality more than other grasses. If the testimony of the present occupier and his neighbours can settle this question (and I see no reason why they should not), the acreable produce is not of greater value, take seven years together, than an acre of good saintfoin, or other artificial grasses. There is more risk in making the meadow-grass than the field-grass, it being very soon spoiled by bad weather, arising from its uncommon luxuriance. I visited this meadow, for the first time, in the month of May, 1811, and found the major part of the crop to consist of *Poa trivialis*, or rough-stalked meadow-grass, with a few *culmi* of the *Triticum répens*, or common couch, and meadow foxtail. In the last spring I again examined the meadow very particularly, and found the crop to consist of the same grasses as before, varying a little in their proportions. The *Triticum répens* made a greater appearance. In the month of August I took another ride to see if florin was taking the lead of the other grasses. This I was prepared for, and expected to find; but it was by no means the case: I could discover no more of the stolonifera than before. On examining the hay of the second crop, it consisted of the *culmi* of grasses common to all meadows, with the exception of the *Triticum répens*. The grass, at this season, prevailed. In soils in general, when laid down to pasture, the common couch (*Triticum*) soon wears out, it will not bear the constant treading of cattle. Wherever this grass is found in pasture, it proves either that the field has not long been laid to pasture, or the soil remarkably rich. The latter is the case in this instance. But you will say, What is the long grass of which we read so much? It remains for me to mention a peculiarity in the grasses in this meadow, and some others in its vicinity, which I do not recollect to have seen in any other to the same degree, arising probably from the warmth and richness of the soil. When the water begins to recede, in the late spring months, the *culmi* of all the grasses (the *Poa trivialis* in particular), from their great luxuriance, lodge on the soil, and form a complete mat, and in this state throw out roots at their joints, and appear, before their panicles show, to be the stolones of some stoloniferous grasses. Let a person, not previously informed of this circumstance, visit the meadow in the latter end of April, and he would probably, with others, suspect the whole, or greater part of the produce, to be a stoloniferous production. I have traced the *culmi*, for instance, of the *P. trivialis* and foxtail amongst the mat of other grasses, for fourteen or fifteen feet, with roots at all the joints, till, at the last, they shot up erect, and were taken off by the scythe only about two feet long. The mat of *culmi* on the ground is left untouched by the scythe when mown, very similar to the stalks of an overgrown crop of vetches. The *Agróstis stolonifera* is one of the latest grasses we have, and never was known, even in a cultivated state, to produce a crop till the autumnal months. But it is asked, 'How is it that it grows so rapidly in its natural state, as to enter largely into a hay crop, cut the last week in May?' Here is the mistake;—the *culmi* of other grasses, throwing out roots at their joints, have been considered as the stolones of this *Agróstis*." (*Farm. Mag.* vol. xiv. p. 151.) These meadows are not laid out in any regular form for watering, the supply of water being too partial, but they depend entirely on the floods; and being situated at a sharp turn of a narrow part of the valley, the water makes an eddy, and deposits its sediments upon them. The substratum of these meadows is an almost entire bed of loose flints.

On examining other meadows in different bournes of this district, we find the same grass uniformly to abound in those situated near the spring-heads, and which in some years have plenty of water, and in others none at all. The same remark on its variation in quality and quantity, according to the wet-

ness or dryness of the winter, is equally just. The most probable way of accounting for it is, that it is almost the only grass common to water-meads that will stand wet and dry; for though it nourishes most when under water, yet no dry weather will kill it.

Live Stock. Cattle few in this district; oxen not generally under the plough; sheep the chief stock and the basis of the Wiltshire Down husbandry; object, folding and wool; breeding a consequence rather than a cause of keeping sheep. Horses a heavy, very unsuitable breed; great error in principle of breeders here as every where among the old school, that of enlarging the size of the animal.

7818. NORTH WILTSHIRE.

Climate milder than that of the S. E. district; soil not so uniform; under stratum broken stones, and surface reddish calcareous loam.

Property more divided than in the east side of the county.

Buildings. Charlton, a noble pile, by Inigo Jones. Farms generally enclosed, and chiefly under grass, and applied to the making of cheese; leases from fourteen to twenty-one years.

Scotch farmers. "Within these few years several of the great landholders in Wiltshire have introduced into this district Scotch farmers, who, from a supposed superior skill in the science of agriculture, have leases for twenty-one years, with scarcely any restrictions as to husbandry. The ancient pastures are allowed to be broken up; buildings are erected for their accommodation at a low rate of interest; and a degree of countenance and patronage given to them above the other tenants of the day. These men give nominally a large rent for their farms; but as their maxim is to pay neither repairs, tithes, nor parochial taxes of any description (these dues and services being all included in the rent received by the landlord), I have strong doubts whether the advantages held out to the landowners will be, ultimately, any increase of net cash into their pockets. In strong loamy counties, or in rich sands, I am aware much profit may be made by an economical system of husbandry in the tillage; but the practice of the Scots farmers not embracing sheep, or water-meadows, will never make them rich on the Down farms of Wiltshire; and if the Downs be broken up by the tenants, who have no stock to maintain them, the land and the farmer will soon come to poverty together." (*Davis*, 174.5.) Among these farmers was the unfortunate Gourlay, who was ultimately ruined by the speculation. Of his farming we know nothing, nor are we aware what description of Scotch farmers they can have been whose husbandry in an inland turnip district did not embrace sheep. On the Earl of Suffolk's estate at Charlton, some Berwickshire farmers were introduced in part through our means, whose chief object was the sheep system. The Lord Suffolk, however, of that time being a weak man, without an opinion of his own, got so alarmed by his family at the idea of breaking up old turf, that he bought up the leases of these farmers almost as soon as they were granted.

The arable part of this district is on the north-west verge, being a part of the Cotswolds hills, and treated like them.

Grass land prevails almost to the exclusion of arable on all wet and heavy lands: their management of late much improved by draining, manuring, winter burning, early mowing, and feeding and mowing every piece of land alternately. The grand object in these improvements is, to get an early bite for the cattle in the spring, and thereby, in fact, to shorten the winter.

The cheese of this district was many years sold in the London market by the name of Gloucester cheese; but it is now perfectly well known by the name of "North Wiltshire Cheese." It was at first, doubtless, an imitation, and perhaps an humble one, of that made in the vale of Gloucester, but it is now allowed by many to be at least equal, if not superior, to the cheese of the favourite district of Gloucestershire, the hundred of Berkeley.

Gardens not numerous: some near Wootton Bassett, for supplying the markets of Cricklade, Cirencester, &c.

Orchards frequent as an appendage to farm-houses, but no cider made.

Wood frequent in hedgerows, but not in masses.

Irrigation not common; springs scanty, and land too absorbent; alleged they produce coarse grass, but this is owing to its not being mown in time.

6. Live Stock.

Cattle of the long-horned breed; Devons bred, and found better for fattening, but it is questionable if they are so good for the dairy. Breeding cattle not the fashion. "The dairymen say, that the advantages which their situation gives them of sending their veal to London and Bath markets, makes it more their interest to fat their calves than to wean them for stock; but the opponents of the long-horned cows say, that the oxen are generally so ugly, and the heifers frequently such bad milkers, that the farmers are never certain of breeding such as they would wish to keep; and therefore they prefer buying cows (of which they can have a choice) to breeding them, and to use horses for the plough instead of oxen."

Many sheep bred in the district; some for folding, and others purposely for fattening; for these purposes a kind to walk, and a kind to stand still, necessary: the Wiltshire answers the former purpose, and the Leicester the latter.

There are yet left in North Wilts a few flocks of the native Wiltshire horned sheep, possessing qualities of perfection, both for folding and fattening. They stand short in the leg, with wool under their bellies; are wide and heavy in the hind-quarter, light in the fore quarter and in all their offals, with the Roman nose, and quick piercing eyes. These are in the hands of a few farmers near Broad Hinton.

7. Political Economy.

As applicable to both districts it is observed, that the turnpike roads are numerous and good in most places; three canals; extensive woollen manufactures at Salisbury; also cutlery of superior excellence there; carpets at Wilton, and fancy woollens; and of superfine broad-cloths at a great many places. No agricultural society, but many farmers and others are members of the Bath and West of England Society.

7819. DORSETSHIRE. 711,250 acres of undulating surface, in great part chalky soil, and celebrated from the time of the Romans for its pleasantness and fertility. Like Berkshire and some other counties, it is called by the inhabitants the garden of England. It is chiefly under grass, and is celebrated for its

breed of sheep, which bring three lambs in two years; and for its watered meadows, of which Boswell, of this county, has given a valuable account. (*Claridge's General View*, 1793. *Stevenson's General View*, 1812. *Marshal's Review*, 1817. *Edin. Gaz.* 1829.)

1. Geographical State and Circumstances.

Climate dry and salubrious rather than mild and bland; supposed colder since the elevated Downs were denuded of their native forests.

Soil chiefly chalk, next clay, then sand, and of loam, gravel, &c. nearly equal and moderate portions. Chalky and sandy soils of the uplands very thin.

No *metallic mines* or cauls, but the peninsula of Portland, four miles and a half in length by two in breadth, one entire quarry of Portland stone, so extensively used, especially in London. Potters' clay found in various parts of the county.

2. Property.

Estates large compared with those of other counties; some of the principal under the care of land-surveyors, others of lawyers. Tenures chiefly freehold and leasehold.

3. Buildings.

Farm buildings as in other counties; generally ill situated, built of stone, and covered with reeds or thatch.

4. Occupation.

Farms very large, 1500 or 2000 acres of sheep farm being frequently to be met with. Many of the proprietors great farmers. Leases of twenty-one years common till the beginning of the present century, now for shorter periods.

5. Implements.

Two sorts of uncooth wheel-plough in use. Small's plough tried in one or two places; from the difficulty of ploughing flinty soils, wheels are deemed an advantageous appendage to whatever sort is adopted. Threshing, winnowing, and various other modern implements introduced in a number of places. The watted hurdles of Dorsetshire consist almost invariably of ten stakes, which the hurdle-makers drive into augur holes, that are made for that purpose in a piece of timber, which is supported at a convenient height from the ground by other pieces of timber, and then the stakes are watted. Stones set on edge, and rublstone walls used as fences in various parts.

6. Arable Land.

Deep ploughing generally less approved of on the chalky soils, and cross ploughing never practised, even for turnips; two or three horses form a team. Fallowing general all along the coast; but what is here termed a summer fallow is, in most cases, no other than a preparation of ley ground for a crop of wheat, by ploughing it three or four times, the first ploughing being given in June or July, and sometimes as late as August.

Upon the thin chalky soils around Blandford, and upon the hills in the neighbourhood of Abbey Milton, the course of crops with the best farmers is as follows: viz. one seventh of the land is in saintfoin, and the rest of the arable is cultivated in the rotation of one, wheat; two, rye, winter barley, or winter vetches, to be fed with sheep in the spring, and the whole followed by turnips, rape, &c.; three, barley or oats; and four and five, artificial grasses, to be followed by wheat as before.

Upon the thin chalks and shallow flinty loams, wheat is generally sown on the hack of a two years' clover ley; but, even on those thin soils, a great deal is sown after turnips, rape, &c. fed off with sheep early enough to sow it in the same autumn, and in most instances a good crop is produced of a fine sample. On the better sorts of chalky and gravelly soils, the same practice prevails, except upon the ley-ground, which continues in grass but one year instead of two; the wheat is taken after the first year's ley, and is supposed to answer better than it would in the second year, upon the latter description of soils. Old saintfoin leys broken up without paring and burning. Hemp and flax a good deal cultivated.

7. Grass.

300,000 acres, or about three fifths of the county; 6000 acres of meadow in the chalky district irrigated. Application of the meadows; fattening cattle, and of the uplands the dairy.

8. Gardens and Orchards.

Both are frequent appendages to farm-houses and cottages; some of the cottage gardens are small enclosures taken from the sides of the highways. The goosefoot (*Chenopodium bonus Henricus*) cultivated by a few persons here, as in Lincolnshire and elsewhere, and calculations made by Batchelor, to show what would be the expenses and profits of an acre for the London market. The plant is greatly inferior to spinach, but might be used as a substitute for it in spring, as it is a perennial, and very early in leaf. Sea-cale, which grows on the shores near Burton, is now generally introduced into the gardens of farmers.

Orchards to the extent of 10,000 acres; application cider, in making which hops are sometimes added to make it keep; proportion one pound to a hogshcad. Twenty bushels of apples will make a hogshcad of cider.

9. Woods and Plantations.

Timber scarce, and chiefly to be found in parks and hedge-rows. Many young plantations lately made on the heath lands.

10. Improvements.

Irrigation carried to considerable extent and great perfection,

7820. SOMERSETSHIRE. About one million of acres, chiefly of meadow and pasture land, hilly and mountainous in some places, and with marshes and bogs in others, but on the whole, though far behind in artificial culture, celebrated for its natural fertility. The climate is various, in general cold and boisterous on the elevated parts, but almost without a winter near the sea. The county is divided into the north-east, middle, and south-west districts, by its very able reporter, J. Billingsley, Esq. of Ashwick Grove. (*Billingsley's General View*, 1797. *Marshal's Review*, 1817.)

7821. NORTH-EAST DISTRICT.

Surface very irregular, intermixed with lofty hills and rich fertile plains: climate various; soil chiefly clay, and in part peat; application chiefly pasturage; several thousands of acres overflowed by the tide in the river Ye0; 4000 acres protected by a wall of stone and lime, elevated ten feet above the level of the land within, but high tides frequently break over it and make breaches.

and one of the best books on the subject is by Boswell of Piddletown. A dry meadow of good quality is worth forty shillings; watered, sixty-five shillings per acre; produce of hay two loads per acre. The streams in Dorset are in general shallow, and have a considerable fall; the meadows are narrow, and the water is supplied with comparative regularity, in consequence of its having to filter through immense masses of chalk previous to its exit at the springs; and hence the process of irrigation is much facilitated.

The *sheep* of Dorsetshire are very known as supplying the metropolis with house-lamb at a very early season. Parkinson considers the Dorset ewe as the best horned ewe in the kingdom, those of Somerset excepted; and they are so nearly alike, that few people, save the natives of the two counties, would know the difference. In the Isle of Portland there is a small breed, which some contend is the true breed of the county. Lowman of Portland observes, it is the practice there to fold these dwarfish animals from Candlemas to Martintide, putting them in late at night, and letting them out early in the morning. The mutton is deemed the best in England, and the wool as good as the South Down kind. Some of them have been purchased by sheep-breeders, with a view to obtain a cross between these and the Merinos. Both ewes and wethers are kept, and generally till they are five years old; sometimes they remain till a greater age, but it is not thought a profitable method. Such as are fattened are put into a common, at the northern part of the island, which is pretty good land, and remain there from the 12th of August to the 5th of November, on which day Portland sheep-fair is held. All the sheep of the island are kept pretty generally upon the commons from November the 21st to Candlemas. The Portland mutton is sold by the quarter in general at ten shillings and sixpence. It is never weighed, but would come to one shilling a pound when common mutton is only seven-pence: it seldom weighs more than ten pounds a quarter. Several flocks of pure Merinos, Down Merinos, and other breeds.

General management of sheep. The lambs which are bred for the regular supply of the flock are dropped at Christmas, or soon afterwards, and the couples are kept in the best ewe-leazes, &c. on grass, hay, and turnips, if necessary; and such as have watered meadows, depasture their sheep there, on the early grass, till old May-day, when the lambs are weaned, and the sheep go to fold; but sometimes the two latter circumstances take place as early as Lady-day. The ewes are folded constantly, and kept on the Downs, on artificial grasses and other pastures, till near the ensuing Christmas, at which time they have another crop of lambs, the rams having been put to the flock about the end of July.

There is, probably, no part of England where the practice of sheep-folding is more admired, or more earnestly pursued, than in the county of Dorset. Fifteen dozen of hurdles, with a like number of stakes and withes to confine them together, will enclose a statute acre of ground, and will contain 1200 or 1300 sheep very commodiously. The hurdles are moved every morning; consequently the same number of sheep will manure an acre of land daily. The real value of the fold there is no means of ascertaining; it is undoubtedly very beneficial to the arable land, but it has reduced the Downs to a state of poverty.

Ewes are generally kept till they are four years and a half old, when they are sold to the dealers. A singular custom prevails of colouring them with ochre, for which no other reason is given than that of being able to distinguish them from the Somerset sheep.

Asses were formerly kept by some farmers, but are now given up, having been found destructive to hedges, &c. "It appeared that six asses would plough as much land of any kind in a given time as three horses, and four asses were sufficient to plough broken land. It is believed that two asses will perform as much work as one horse, and they do it more conveniently in the hilly part of the county, as they carry their lading in panniers, where it would be difficult to use wheel carriages.

Geese kept on the corn pastures in Purbeck, from an idea that they promote the health of the cattle.

Bees kept in various places; does not answer to feed them; the only way to render them profitable is, after the honey-season to destroy all hives under twenty pounds weight.

11. Political Economy.

Roads of flint, and in general good: an iron railway, of three miles and a half, for conveying potters' clay from Norden to a place opposite Poole, where it is shipped for Liverpool. No canals. Manufactures of flax and hemp at Bridport and Beaminster; upwards of 2000 people employed in making sail-cloth, cordage, sacking, tarpaulin, &c.; flannel at Shaftesbury, and woollens at Lyme Regis; twisting and making up raw silk into skeins at Sherbourne and other places; shirt buttons extensively at Shaftesbury, Blandford, and the surrounding villages; the buttons made of wire and thread; many thousands of children in this manufacture: wicker baskets, with a small hole at top, called lobster pots, at various places on the coast, and a variety of other articles. Many very uncommon provincial terms used in this county.

Minerals. Lead and calomine in the Mendip hills, but little worked, for want of a proper level to carry off the water. Coal abounds, and is worked for the supply of Bath, Wiltshire, and Somersetshire; from 800 to 1000 tons raised weekly.

Property. Many large proprietors from 2000*l.* to 6000*l.* per annum, but the greater part in the possession of respectable yeomanry, from 50*l.* to 500*l.* a year.

Buildings. There are many splendid gentlemen's seats,

ornamented with extensive plantations, in this district, and the farm-houses and cottages are for the most part commodious and comfortable; but, on all the dairy farms, a shameful inattention prevails in respect to outhouses and sheds for their stock to retire to in the winter months. Cattle are almost universally served with their provender in the field; and many a dairy farmer, with twenty cows, scarcely makes, in the whole winter, a quantity of dung sufficient to manure one acre of land.

Occupation. Farms seldom exceed 200*l.* a year; some of the dairy farms are so small as not to exceed 60*l.* or 70*l.* per year; and many instances can be produced of such little farmers bringing up a large family in a very respectable way. In such instances, it is generally found that the wife undertakes the whole management of the cows, and the husband goes to daily labour.

Implements. Plough with a foot or wheel; spade with the blade curved in its breadth, to prevent adhesion of soil; it is much narrower and longer than those used in other counties, eighteen inches by six inches.

Arable land but in small proportion, and little attended to. Teazles and woad grown for the clothiers; potatoes cultivated to a very considerable extent. The reporter has known thirty-two successive crops of potatoes from the same field, and the produce as good at the latter part of the term as at the beginning. This will puzzle the theorist, with his peculiar substances of nutrition. A sack of potatoes is equal to a hundred weight of hay.

Grass the predominating surface. "On the rich marsh land near the Bristol Channel, the grazing system prevails. In the vicinity of Bristol and Bath, the scythe is in constant use; and at a greater distance nothing is scarcely seen but the milking pail: on the stonebrash, and freestone grit soil, saintfoin takes the lead: next to saintfoin, rye grass, marl grass, and white Dutch clover are in deserved repute, when the land is intended to remain some years in grass; but when it is intended to be ploughed again in the course of a year or two, broad clover is preferred to all others.

Hay-tea (1807.) much in use, by which means it is considered as much nourishment is obtained as if the hay were eaten, while after boiling the culms may be dried and used as litter! In some places, however, a prejudice exists against using hay for litter, on the supposition that it breeds vermin in cattle.

Market Gardens for the supply of Bristol and Bath. A clergyman has eight or ten acres of nursery ground, the labour of which amounts to 25*l.* per acre.

Orchards abound throughout the whole district; the favourite apple, both as a table and cider fruit, is the court of wick pippin, a seedling from the golden pippin.

Woods and Plantations not numerous.

Live Stock. Cattle mostly short-horned; the long-horned breed of North Wiltshire have been tried, but the customary breed preferred. Both cheese and butter made.

Roads pretty good; some canals; woollen manufacture extensive, and that of knit worsted stockings considerable.

7822. MIDDLE DISTRICT.

Between 4 and 500,000 acres of varied surface and soil, and mild climate; including a great extent of marsh and fen land, great part of which has been drained and embanked. Half this district occupied by the owners. Grass the chief product; farms from 40*l.* to 600*l.* per annum, partly grazed with heifers, but chiefly by cows for the dairy: the cows let out to dairymen, as in Dorsetshire.

Arable Land, flax and hemp extensively cultivated, and also turnips.

Orchards numerous and very productive; soil particularly suitable; plantations few.

Live Stock. Small cows, well fed, preferred for the dairy, and the object chiefly cheese; that of Cheddar much admired, the others in general sold in London as double Gloucester. A dairy-maid can manage the milk of twenty cows.

Roads excellent, especially from Wells to Bridgwater; extensive woollen manufactures, many of hemp and flax, and some of gloves.

7823. SOUTH-WEST DISTRICT.

Rough mountainous hills, and rich fertile slopes and plains; farms rather less than in the last district, but the husbandry much the same; more land in tillage; mountains uncultivated, and pasture with sheep and young bullocks; in the vicinity of these hills the principal corn crop is oats.

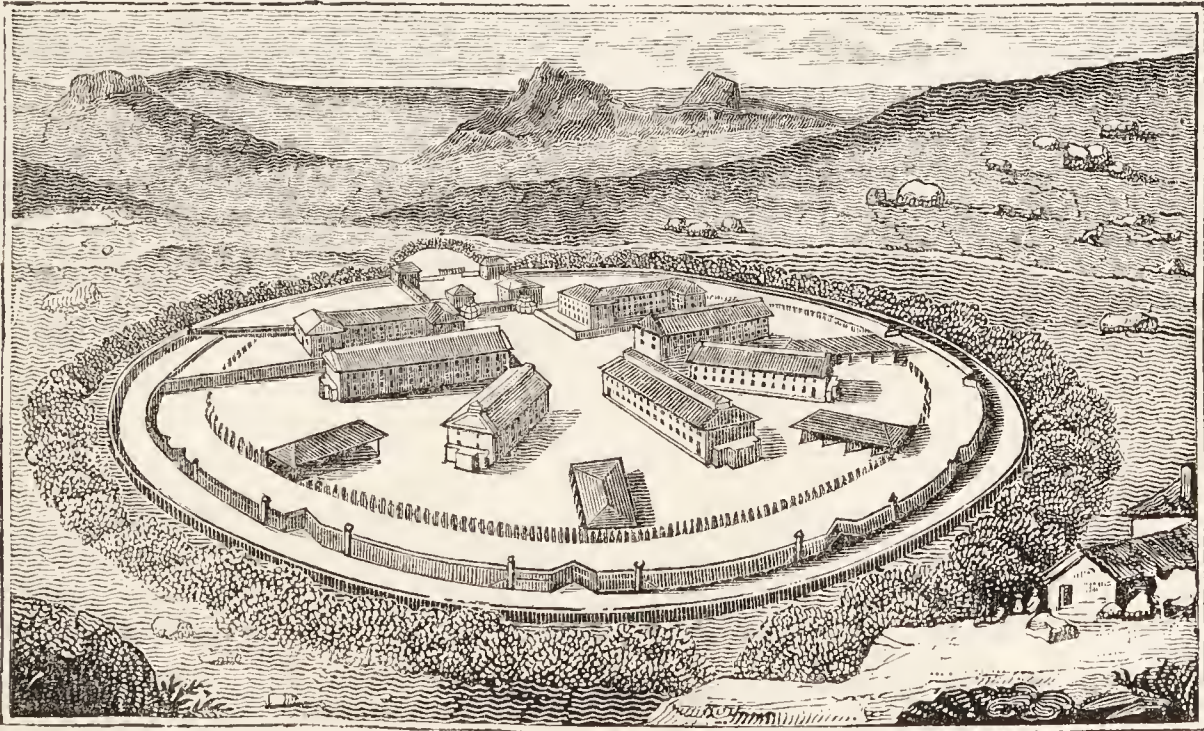
Fences. The beech hedges around Dulverton, Dunster, &c. are not only beautiful to the eye, and excellent fences and shelter, but are a source of annual profit to the proprietors. The hanks on which they are planted are six or seven feet high, and between four and five feet wide at the top; the mouldering of the sides is frequently prevented by a dry stone wall, four feet high. There is no ditch; and the hedge consists of three rows of beech, planted on the top of the bank, at about one foot distance. Their growth is very rapid, and they seem to defy the destructive qualities of the sea breezes, so fatal to the white-thorn, and most other plants; when at maturity, the middle row is cut to the ground, and the outside rows plashed. The quantity of fuel supplied by these hedges is very considerable; and the only objection that can be made to them is, that the earth used in the construction of the banks is so considerable a quantity, that a large portion of the field is robbed of its vegetable matter, and rendered for some years unproductive.

Some *Norfolk farmers* introduced on the Barnard estate, and rhubarb cultivated to great perfection by Ball, at Wililton, near Watchet. Many orchards, and excellent cider made; not much wood, but elms attain to a large size in the hedges.

Live Stock. North Devon cattle and Dorset sheep used round Taunton Dean; oxen worked chiefly in yokes. Manufactures at Taunton on the decline. A salmon and herring fishery at Porlack, Minehead, and Watchet.

7824. DEVONSHIRE. 1,595,309 acres of strongly marked hilly surface, including the vale of Exeter, "the garden of the west;" the Forest of Dartmoor, a barren waste; and North, West, South, and East Devonshire, each with distinct features. The county is celebrated for its breed of cattle, its dairy, and its orchards, and of late years for extensive improvements undertaken in Dartmoor, where is also the immense depôt for 10,000 prisoners of war. (fig.1114.) (*Tyrwhitt's Tracts on the Improvements at Dartmoor*, 1819 *Fraser's General View*, 1794. *Vancouver's View*, 1807. *Marshal's Review*, 1817.)

1114



1. Geographical State and Circumstances.

Climate in North Devon less mild than in South Devon, but still myrtles are used as garden hedges; in South Devon the climate is supposed more mild and salubrious than in any other part of England.

Soil in great variety, but in general calcareous.

Minerals. Some iron and copper worked, also freestone, limestone, and marble, &c.

2. Property.

Much divided, only a few large estates; formerly letting for lives much in use. It has frequently happened, that in letting

an estate, the landlord agreed to discharge tithes and all parol payments. About the years 1800 and 1801, the rent of several estates in this county was absolutely insufficient to meet such disbursements, and consequently all the estates so circumstanced brought their proprietors in debt.

3. Buildings.

Houses of proprietors too generally going to ruin from non-residence. "We defy ingenuity to plan and place farm-houses worse than they are." "Garden-walls, farm-houses, barns, stables, lime-kilns, village fences, and cottages, are all built

with mud, and left without rough-cast, or whitewash, to conceal the native colour of the loam."

4. Occupation.

Farms of all sizes from 10*l.* to 500*l.* a year.

5. Implements.

Plough of the swing kind, with a wooden mould board. Scarifiers, called tormentors. Two sorts of grubbing mattocks are in use (*fig. 1115, a, b*), one called the hoe mattock (*a*), and the other a two-bill or double-bitted mattock (*b*). Paring-shovels (*c*) are very well constructed. Corn-stacks in harvest secured from the sudden and heavy thunder showers to which this country is liable, by canvass coverings, like those used in Middlesex for covering hay ricks.

6. Arable Land.

Much less than the grass land; not much to be learned from its culture; artificial herbage not generally sown, and rotations bad.

7. Grass Lands.

In the low tracts of good quality; application, breeding and the dairy; butter good, cheese indifferent, and generally consumed in the county.

8. Orchards, Woods, and Plantations.

Very abundant in most parts of the county, and excellent cider made in the Herefordshire manner. Fruit trees rather neglected than otherwise; generally pasture beneath; often in the hedgerows.

The Forest of Dartmoor is parcel of the Duchy of Cornwall; extensive improvements have lately been proposed, and in part carried into execution, under the direction of Sir J. Tyrwhitt, the steward of the Duchy. Extensive salt marshes on some parts of the coast.

9. Improvements.

Draining and irrigation not much practised. The Rev. M. Froude, of Darlington parsonage, communicated to Vancouver a mode of emptying the water from a pond without the necessity of attending to it personally when full. It is more matter of curiosity than ingenuity or use. The water, when the pond is overflowing, flows by a gutter into a basin, suspended beyond the head, which when full, by means of a lever, raises a plug at the bottom of the pond. After a time, the box being leaky, it becomes empty, and when the pond is nearly empty, the plug re-drops in its place. If the plug were placed nearer the surface of the water, it would in general cases be more useful, and less likely to lose the fish.

10. Live Stock.

The North Devon cattle well known for their superior adaptation, both for feeding and draught. For the uses of the dairy or for milk, it is a breed by no means held in general estimation, as their aptitude to look well (without being fleshy) is derived from the peculiar nature of the animal, which disposes its secretions in the accumulation of fat, rather than in the production of milk. For the purposes of labour, this breed can nowhere be excelled for docility, activity, or hardihood, in proof of which no stronger circumstance can be adduced, than that it is a common day's work, on fallow land, for four steers to plough two acres with a double-furrow plough; and that a general use is thus made of them, and for most of the other purposes of draught in the county where they were originally found, and in others to which they have been since transplanted.

The rules generally pursued in breeding and raising this valuable animal, may be considered as follows:—The greatest number of calves fall between Candlemas and May, and some much later; but, among the best breeders, such late calves are not so generally approved of. The usual mode of raising them is, to let the calf suck as much as it will three times a day, for the first week; then bring it to the finger, and feed it with warm new milk, in like manner for three weeks longer. This is the ordinary treatment for the first month, and the calf is then fed for two months longer, twice a day, with as much warm scalded skim-milk as it will drink; when, gradually abating its morning and evening meals, at the end of four months the animal is weaned from all milk draughts, and left to itself. Small portions of finely pounded linseed cakes are often used, and recommended to be mixed with the skim-milk, particularly in the first period of its being given in the place of new milk.

The full-sized North Devon cow, when fattened to its frame, will not exceed eight score per quarter; and the ordinary average of its ox, at five years old, and equally well fattened, must not be rated higher than three score per quarter above the weight of its fattened mother.

The usual practice in this district, is to sell the steers, at four or five years old, to the graziers in the county of Somerset, who feed them for a supply to the Bath, Bristol, and London markets. Very few in the proportion raised are fed in the district, which may in a great measure be ascribed to the great indifference hitherto manifested in the culture of green food for a winter supply; and for which, indeed, a sufficient reason may be drawn, from the deplorable wet state in which the lands are suffered to remain from the want of draining.

In South Devon we find a mixture of the North Devon with a larger animal of the same kind, called the Old Marlborough Red. This breed is said to have originated from the South Malton stock, although at this time they differ very materially from them in size, and in having a dirty brown, or rather blackish colour at the ears, nose, and encircling the eyes, and in all such parts as the orange hue prevails in the genuine North Devon breed. A cross with this breed is, however, much preferred, as it produces a greater aptitude to fatten in a given time than is experienced in the South Devon stock, which in all its points is a much coarser animal, and produces a greater offal. There does not appear to be any particular choice with regard to colour in this breed.

Sheep, the Exmoor breed, a horned animal, with a moderately long staple of wool, which heretofore, and before the cloth manufacture fled from this county into Yorkshire, was much used by the clothiers of North and South Malton, Collumpton, Thorverton, Tiverton, and other places in the county.

The sheep most approved in the division of Tiverton are the Bampton Notts. The first cross of this breed with the New Leicester is growing greatly in esteem, from its improving the form, and bringing the animal three months sooner to market.

The sheep generally depastured on the moorlands are the Exmoor, Dartmoor, and the light hardy breed of the lower moors and commons in the county. The autumnal rains frequently inundating the cold clay lands, are very apt to occasion the caw, or rot, among them, and which has been sometimes experienced to an alarming extent.

The Merinos, Ryelands, Downs, and other fashionable breeds have been tried by amateurs; but Devon is less a sheep than a cattle county. Native breed of hogs large, and long-legged.

Horses, a small compact breed; with the exception of the farm-horses in Ireland, those in Devonshire have perhaps as hard a measure of neglect and ill-usage dealt out to them, as in any where to be met with in the united kingdom.

11. Political Economy.

Had the roads of this county been laid out in the judicious manner practised by the Indians of North America, they would have been found to follow the water courses in all cases where they might lead in their general direction, towards the point assigned for carrying them. In doing this, infinitely more judgment would have been displayed, and a far greater benefit secured to posterity, than in that which has been adopted by the original projectors of some of the most important and most frequented roads in this county. This is clearly demonstrated by the road between Barnstaple and Chumleigh, which, instead of being conducted through the valley of the Taw, is carried over the highest brows of the river hills, where the traveller is unceasingly compelled to ascend and descend the sharpest hills in the county. The same may be said of the road between Bideford and Torrington, by the great omission of its not being carried along the foot of the river hills, and through the valley of the Torridge river.

Manufactures of woollen of various sorts were formerly common; but are at present on the decline; many manufactures and works employing numerous hands at Plymouth. Two agricultural societies, but both ill attended and on the decline.

Education of the Poor, or Lower Classes. Vancouver concludes his report by some pages of observations which, happily, are seldom equalled in illiberality; and, viewing the subject as we do, they compel us to look on him as an enemy to human nature, and to turn from his book, his name, and memory, with feelings of dislike. "It is an incontrovertible truth," he says, "that the restless disposition of the Irish, and their emigration to America, is owing to their being generally instructed to read and write. The disposition of the Scotch and Germans to emigrate arises from the same reason, and the English peasant under the same influence will be acted on in the same manner." He "respectfully submits to the consideration of the Honourable Board, the propriety of opposing any measure that may rationally be supposed to lead to such a fatal issue." This man, like Charles X. and his ordinances of 1850, and Wellington, with his speech against reform of the same year, may have done good without knowing it.

Marshal, whose considerate and humane spirit justly objects to the term peasantry, as at all applicable to the operative classes of Britain, has the following excellent remarks on this subject:—

With respect to the emigration of the Irish, "well it is," he says, "for Ireland and America, that they do so. The one is overstocked with the class that furnishes work-people; the other wants enlightened workmen. Of slaves and savages it has enow. The unlettered Irish stay at home, to riot, plot, and murder; to commit acts of treason, stratagem, and spoil; or emigrate to England, to revel awhile in outrage, and be hanged."

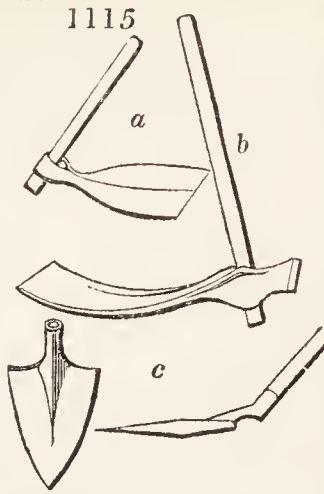
On Vancouver's ideas on education, Marshal observes, "After some other groundless arguments, the reporter sums up in Italics, and with the aid of foreign tongues, in the following ultra-royal manner:—'In short, the peasant's mind should never be inspired with a desire to amend his circumstances by the quitting of his cast' (this, says Marshal, is Hindoo), 'but every means the most benevolent and feeling heart can desire should be employed to make that situation as comfortable and as happy to him as possible; and to which end nothing more essential could contribute than by exciting a general emulation to excel in all their avocations, even to those of breaking stones for a lime-kiln, or for repairing the high-ways.' 'Hear, hear!' says Marshal—'This is English.' Good heaven! And is there an Englishman (or a Dutchman— they are brothers in sentiment) with nerve enough to write the two first lines above quoted!!! He surely could not know that many men of 'the brightest genius,' and who are much more estimable members of a community,—many great and good men have, in England, been moulded and nurtured in the 'peasant cast.'"

"Fortunately for society in England, the writer's exotic notions have not taken root. Seminars, for civilising the children of the labouring classes, have been, and are rapidly increasing."

"In a civilised nation, early schooling tends to reclaim children from savage propensities, and to prepare them for civilised society; inculcates a propriety of behaviour, one of the very first lessons a child should be induced to learn in a civilised nation. In the savage state, savage manners may be deemed a virtue, as being, in that state, conducive to self-preservation."

"Attendance in a school inures children to a requisite degree of restraint; and a division of time employs their minds, and prevents idleness, and other vicious habits, from taking root; thus tending to raise them to the rank of rational beings. While the unfortunate offspring of indigence, that are suffered to loiter away their early days on commons, in lanes, and by-places, acquire habits of indolence and pilfering; give a loose to their own wills and unrestrained tempers; commit acts of mischief, and add to them the guilt of lying (the seed-bed of fraud) to screen them from correction."

"The discipline of a well governed school impresses on youthful minds subordination, industry, patience, and its



consequent, perseverance; and thus habituates them to receive instructions."

Where Vancouver is at present we do not know; we hope he may long live to witness the extension of education which is now taking place, not only in this, but in almost every country

in the world; and we hope all those whom he designates peasantry, who may ever happen to read the above extracts, will see the necessity of fortifying themselves, by knowledge and good conduct, against the degradation attendant upon ignorance and vice.

7825. CORNWALL. A peninsular hilly surface, of 758,484 acres, remarkable for its mines, and of late greatly improved in its agriculture, the object of which is chiefly corn. It is the country of Sir H. Davy, who may be considered as having eminently contributed to agricultural science by his agricultural chemistry. The inhabitants have been remarkable from the time of the Romans for their mildness and complacency of temper, urbanity, hospitality, courteousness, and liberality. (*Frazer's Cornwall*, 1794. *Worgan's Cornwall*, 1810. *Marshal's Review*, 1817. *Edin. Gaz. abridged*, 1829.)

1. Geographical State and Circumstances.

Climate, like that of other peninsular situations lying far to the south and west, inconstant as to wind and rain, and mild as to heat and cold. Plants, shrubs, and even the most hardy trees on the sea-coast, sustain much injury from the violence of the westerly wind, and the salt spray of the sea, which it drives with great force before it; hence crops of wheat and turnips have been totally destroyed. After a storm, the plants have their roots much torn, and their leaves corroded and shrivelled as if scorched, and taste of a pungent saltness. Trees and shrubs shrink and lean away to the eastward, and appear as if clipped by the gardener's shears. The only shrub which seems to bear the sea air is the tamarisk.

Surface remarkably unequal; ascents and descents follow in rapid succession; some hills very steep.

Soil generally slaty and loamy, mixed in a manner that renders it almost impossible to designate the boundaries and extent of each.

Minerals chiefly tin and copper; for the former Cornwall has been famous from the remotest antiquity, as some think, from the days of the Phœnicians.

2. Property.

Very much divided, subdivided, and vexatiously intermixed. Estates from twenty acres to 500 acres, very few exceeding 400*l.* per annum. Many gentlemen and clergymen in this county occupy their own estates and glebes, and keep their grounds in a very superior state of cultivation. The management of great estates is generally given to attorneys.

Entailed estates. "I was in hopes that I had been a singular sufferer in Cornwall, from this kind of deceptive tenure; it would then not have been worthy of notice; but in my excursions through the county I have met with fellow-sufferers, and with others who are likely to become so. As such cases have occurred, and may occur again, it behoves every man who is about to occupy a farm for a term by lease, to make enquiry whether it be an entailed estate or not; because the possessor having the power of letting for his own life only, in case of his death, the occupier is left entirely at the mercy of his successor." (*Worgan's Survey*, 22.)

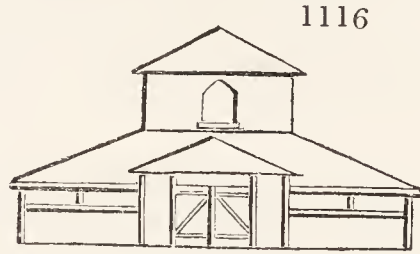
3. Buildings.

Old farm-houses of mud and thatch; the lower divisions consist of a kitchen, and an apartment dignified with the name of parlour, but called (provincially) the higher side, a cellar, and dairy-room; but these latter are frequently under a lean-to roof; the rooms very low, not ceiled, and two bed-chambers over; the floors of the chambers are of oak plank; the ground-floor earth, lime-ash, or flag-stone.

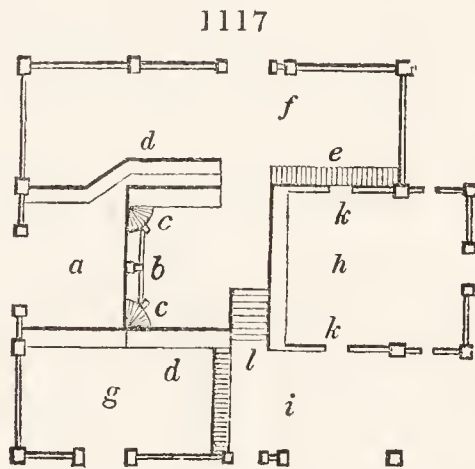
The farm-offices, built of the same materials, consisting of a barn, cow and ox sheds, and hog-sties, stand in confusion about the dwelling. The intervening and circumjacent ground is called the farmer's town-place; for as to that essential appendage, a regular farm-yard, it is a convenience not often met with in any part of the county.

Some good new farmeries erected centrally on newly enclosed lands. One for forty-six acres has a very neat elevation (*fig.* 1116.), and the plan (*fig.* 1117.) contains a feeding place into which the turnips are carried (the cart being backed into it), and from whence the sheep and oxen are fed (*a*); place for a yoke of oxen (*b*), either for soiling or winter-feeding: the oxen are tied to posts (*c*); there are troughs for turnips (*d*); cribs, or racks for hay or straw (*e*); lean-to, for store sheep (*f*); lean-to, in which half a score sheep are kept to fatten, the number

being completed again soon as any are sold (*g*); fodder house, used as a barn (*h*); open shed for tools (*i*); hanging doors with



bolt inside, and through which the fodder is handed to supply



the cattle, and is thus kept always dry (*k*); door and staircase leading up to the wool chamber (*l*). The stairs rise quick, so as to be quite out of the way of the ox feeding in that side of the house.

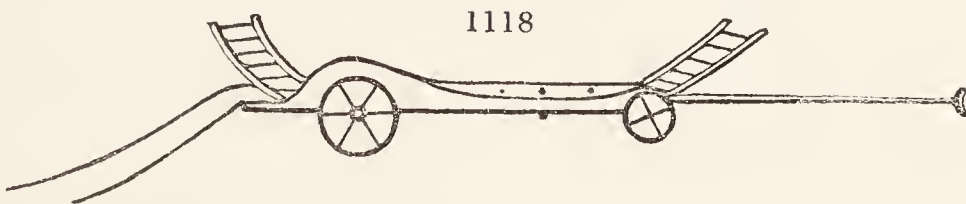
Cottages. "I had occasion often, in my dreary walks during my survey, to take shelter in some of these miserable dwellings, and found the poor inhabitants busy in placing their bowls, crocks, and pans, to catch the water pouring in at the roof. However, the meanest cottage generally has that great source of comfort, a garden, attached to it." Some very comfortable plans of cottages, by Captain Penson of Ethy, are described by the surveyor.

4. Occupation.

Farms from three or four to three or four hundred acres, mostly from 30*l.* to 50*l.* a year. Leases on rack-rented farms generally from fourteen to twenty-one years.

5. Implements.

No county affords a greater variety of wheel and other carriages. The harvest waggon (*fig.* 1118.) has a lade before and

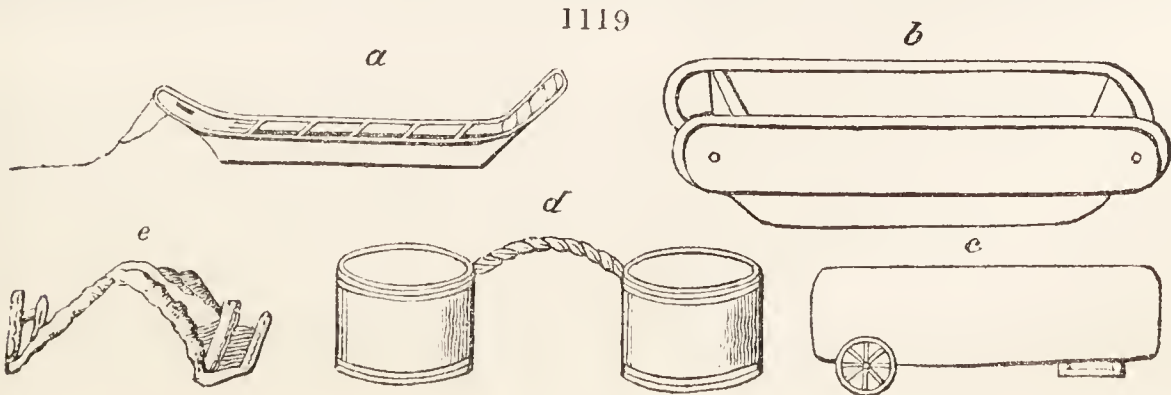


behind, and is open in the middle, it carries about 300 sheaves of corn. When drawn by horses, shafts are applied; when by oxen, a pole. An arch of boards over the hind wheels prevents the corn from bearing on them.

sand hay. It consists of a light, open, long body, borne upon two wheels; a railed arch over the wheels prevents the load from bearing upon them; it will carry from 200 to 250 sheaves which are secured by ropes, it having no sides or lades.

The *vain* is another light useful carriage for carrying corn

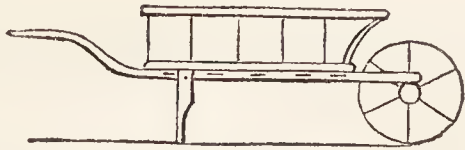
A *sledge* for corn, hay, or faggots (*fig.* 1119. *a*); slide butt (*b*);



quarry butt for earth or stones (c); dung-pots or dung-panniers (d) for dung or stones; and panniers with hooks, for faggot wood and sheafed corn (e), are also in use.

Box hand-barrows and grass barrows (fig. 1120.) are also used on a few farms.

1120



The Cornish plough is a small swing plough with a straight piece of wood as a mould board.

Barn boards for threshing on are four or five planks laid across beams, but about one third of an inch asunder; so that the corn as it is threshed may fall through and not be bruised. In some places wheat is separated from the straw by beating it on a barrel or inclined plane, usually by women. Fences generally made of stone, or raised banks of stone, slate, and earth, sometimes planked.

6. Arable Land.

The pilez, or naked oat, cultivated on worn-out ground; its straw very fine, and reckoned nearly as good as hay. A quantity of potatoes exported yearly; but not enough of wheat grown for home consumption.

7. Grass.

Chiefly near towns and villages, on sheltered slopes, and the uncultivated lands known as moors, downs, crofts, and wastes; some meadows watered.

8. Gardens.

Common to cottages and farms, and better attended to than in most counties; orchards also attached to many farms.

9. Woods and Plantations not abundant.

10. Improvements.

Draining practised to a considerable extent, and one or two examples of embanking.

The maritime situation of Cornwall presents the farmer with three valuable manures; fish, sea sand, and sea-weed. In some years the farmers who live in the vicinity of fishing towns have an opportunity of buying the bruised and small pilchards; which being deemed unfit for market, are rejected and called "coff;" four cart-loads of twelve bushels are considered as the proper quantity for an acre. The usual mode of management is to bury the coff in a pile of earth, deep enough to secure it from dogs and hogs, adding to the pile a sufficient quantity of sand, well mixing and turning all together after having lain some months. Without this practice the fish would not decay sufficiently for perhaps a year or two. The fish are sometimes used alone; they are then spread thinly over the ground before the plough, and turned under furrow. One pilchard cut up small will amply dress one square foot of ground.

The old salt which has been used to cure the pilchard, and judged to be no longer fit for that purpose, is advantageously applied for a barley or a turnip crop; twenty to thirty bushels

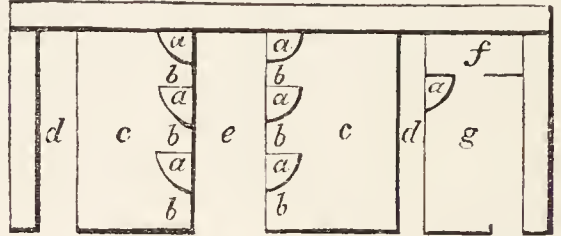
per acre. It is commonly hand-sown, in the manner of corn; and it should remain on the land five or six days before the seed is sown. It is best adapted to light lands, particularly furze crops. Twenty bushels per acre have been strewed over grass lands, and over a wheat crop, in the month of March, with evident advantage.

Another article of manure obtained from this useful fish is the liquor which drains from it while under the process of curing, consisting of blood, brine, and some oil which escapes, and which is caught in pits; the diligent farmer carts this away in casks, for the purpose of pouring over and mixing with his piles of earth and sand, which it greatly enriches.

11. Live Stock.

Devonshire cattle prevail; but it is only among the more enlightened and spirited breeders that the genuine North Devon are to be met with. Cows are kept in winter in sheds open to the south; one of which for seven cows and a fatting calf (fig. 1121.), described by the surveyor, contains cribs for hay or straw in winter, and lucern, vetches, &c. in summer (a); troughs for turnips, potatoes, cabbages, &c. (b); beds or platforms for the cows to stand and lie on (c); gutters sunk two or three inches to receive the dung (d); head-way and feeding place (e); dark place for fatting a calf (f); the division outside (g) for a cow that has, or is near having, a calf. She is not tied up.

1121



The cows are tied to posts by means of a strong chain and rope, which by means of a ring runs on a long staple.

Oxen very generally worked both in plough and cart; shod in brakes, and yoked in the bow.

Sheep a mixed breed; Cornish breed lost among crosses.

Horses a small hardy active breed, well adapted to the hilly nature of the county.

Cornish hog always white; a long-sided razor-backed animal; crossing by the Devon, Suffolk, and Leicester breed, has taken off length and sharpness, and added breadth and depth; a mixture of Chinese and Suffolk is another variety.

12. Political Economy.

Public roads tolerably good; lanes bad. Some travellers who met Pargan, the reporter, hoped he would notice with reprehension the straw-traps that the farmers lay in some of the cross roads, and which, concealing the deep ruts, endanger their horses, gigs, and their own necks.

Manufactures few; some of woollen carpets, and paper. The three great staple commodities for export, are tin, fish, and copper, the moor stone, China stone for porcelain, barley, oats, potatoes, and some wheat.

7826. The islands of JERSEY, GUERNSEY, ALDERNEY, and SARK, which lie in the Bay of St. Michel, and form the remnant of the ancient Duchy of Normandy, though naturally belonging to the continent of France, have yet for nine centuries been subject to the British Government. The agriculture of all of them is nearly the same; but we shall follow the Reporter to the Board of Agriculture in considering first that of Jersey, and next Guernsey. These islands are chiefly remarkable for their breed of cattle, their parsneps, and the degree of perfection to which many plants arrive in the open air, which are kept in England under glass. (Quayle's General View, &c. of the Norman Islands, 1812.)

7827. JERSEY, 39,580 acres of warm and rather moist climate, diversified soil, and features: the soil is for the most part light, on granite or schistus, and there is some peat and marsh. No calcareous soil or rocks; granite and gneiss quarries worked; and granite pillars of fifteen feet in length extracted. Water abounds; and belief is still entertained in the efficacy of the divining rod for discovering springs.

1. Property.

Minutely divided, and mostly in the hands of a resident yeomanry. Some singular laws and customs as to tenures, as, for example, the *retrait lignager* and *retrait seigneurial ou foedal*; also the legitimization of children not born in wedlock, by the marriage of their parents, as in Scotland, and most other countries of Europe except England.

2. Buildings.

Those of all classes substantially built of stone, sometimes rough-cast, neatly lined in imitation of squared stone-work. Farm-houses generally covered with thatch or pantiles. Cottages generally of stone, with a vine in front.

3. Occupation.

Farms small, and fields diminutive; farmers frugal, and their wives good managers, and industrious.

4. Implements.

Plough with wheels, resembling that of Hampshire; sometimes drawn by two bullocks, and six or eight horses; a sort of large plough used for ploughing deep, for parsneps, and held in partnership by several farmers; instances of this plough being drawn by six oxen, and sixteen horses. (p. 64.)

5. Enclosing.

Fields very small and irregularly shaped, and the fences of high earthen mounds, often twelve feet wide at least, and six feet high, crowned with a hedge, or timber trees and pollards.

6. Arable Land.

Soil deep, and deep ploughing generally practised, but no improvement in it for ages; no naked fallows. The spelt wheat (*Triticum Spelta*), here called *blé tremais*, *frumentum trimestre*, here enters into rotation; it is sown in February, produces short stiff straw, is difficult to thresh, but never lodges.

Parsneps are grown by every farmer, and either by the spade culture alone, by the plough and spade, or by the small and great plough; any soil in good heart and tilth suits them, but peculiarly a deep loam; and in the same spot generally are raised beans, peas, cabbage, and occasionally potatoes.

When the ploughing or digging is completed, the field is once harrowed; straight lines are then drawn across, by means

of a gardener's rake, usually from north to south; women then proceed with dibbles, and set the beans in rows, at a distance of four inches or five inches from bean to bean; in four, three, and sometimes in two ranks of beans, leaving intervals of five or six feet between each of the sown rows. In the use of the dibble, and in dropping the beans, the women have acquired considerable dexterity. In many instances, they are followed by children, who drop into each hole made by the dibble, after the bean, three or four peas; the parsnep seed is then sown, at the rate of one third to one sixth of a bushel to the acre.

The parsnep, not usually relished elsewhere as an article of human food, is here consumed by all classes of people; it is eaten with meat, with milk, and with butter; but not, as is the common mode of using it as human food in England, with salt fish; or, as in Ireland, together with potatoes.

The next most valuable application of this root is hog-feeding; at first it is given to the animal in a raw state, afterwards boiled or steamed, and finally, for a week or a fortnight with bean and oat meal. A hog, treated in this way, is sufficiently fattened for killing in about six weeks. Its flesh is held superior to that arising from any other food, and does not waste in boiling.

Bullocks are also fattened with parsneps, in about three months; their flesh is here considered of superior flavour to any other beef, and commands, on that account, an additional half-penny in the pound on the price. To milch-cows they are also usually given; on this diet the cream assumes a yellow colour; by the accounts here given, it appears, in proportion to the milk, to be more abundant than when the animal is kept on any other food whatever. When the cow receives at the rate of thirty-five pounds per day with hay, seven quarts, ale-measure, of the milk produce seventeen ounces of butter. It is generally allowed, that the flavour of the butter is superior to any other produced in winter.

Geese are sometimes shut up with the hogs, to fatten on parsneps, which they will eat raw. The root is also given boiled, and for a week before killing they are fed with oats or barley only. Horses eat this root greedily; but in this island it is never given them, as it is alleged, that when on this food,

their eyes are injured. About Morlais, horses are not only ordinarily fed on parsneps, but they are considered as the best of all food, superior even to oats.

Lucern a good deal cultivated, and found productive.

Hops to a moderate extent; the reporter could not find that the *Teucrium Scorodonia* was employed as a substitute, as related in some botanical works. A species of *Cyperus* (most likely *Carex arenaria*) used for twisting into halters and other ropes.

7. Grass Lands.

Of very limited extent, but meadows very productive.

8. Gardens and Orchards.

Very productive, and in general carefully attended to. Chaumontelle pears brought to great perfection, and with grapes, bulbs of the Guernsey lily, parsnep seed, and some flower seeds, sent to the London fruiterers and seedsmen.

Orchards generally attached to all farms. Jersey cider in much esteem, and a principal article of export. Most of the farm-houses have large arched doors, made wide on purpose for the passage of cider-casks. A valuable work on the subject of cider by the Rev. F. Le Conteur, entitled *Aperçu sur la Culture des Pommes*, Jersey, 1806. The pomeril, lamme, noir-toit, and gros-amer, the cider-apples at present in vogue.

9. Woods and Plantations.

Very limited extent, and the waste ground a little more so; only about 500 acres of rocky summits of hills; these might be planted.

10. Improvements.

No calcareous manures found on any of the Norman islands. Sea shells tried on clay with great advantage; and sea weeds (*vraic*, whence *vack*). Irrigation in a simple manner, practised in the narrow valleys from time immemorial. Sea encroaching in some places, and jetties and embankments proposed, but nothing done.

11. Live Stock.

Alderney cattle well known. Though there can be no doubt that the breed was derived from the contiguous Continental coast, yet it is not known that in any part of it at present the same breed is preserved in equal purity. Next, perhaps, to the possession of *vraic*, the treasure highest in a Jerseyman's estimation is his cow. She seems to be a constant object of his thoughts and attention: that attention she certainly deserves, but she absorbs it too exclusively; his horse he treats unkindly; his sheep most barbarously; but on this idolised cow his affections are rivetted as firmly as those of an Eastern Bramin on the same animal. It is true that in summer she must submit to be staked to the ground; but five and six times in the day her station is shifted. In winter she is warmly housed by night, and fed with the precious parsnep. When she calves she is regaled with toast, and with the nectar of the island, cider, to which powdered ginger is added. Could she be prevailed upon to participate in all her master's tastes, there is no doubt but that he would willingly bestow on her the quintessence of *vraic* itself.

To guard the purity of her genealogy, and to prevent others from being conveyed to England, under the semblance of Jersey cows, he has invoked the interference of the insular legislature. On the 8th of August, 1789, an act of the States passed, by which the importation into Jersey of cow, heifer, calf, or bull, is prohibited under the penalty of 200 livres, with the forfeiture of boat and tackle. A fine of fifty livres is also imposed on every sailor on board, who does not inform of the attempt. The offending animal is to be slaughtered without

mercy on the spot, and its flesh distributed among the poor. The same act of the States directs, that when cattle of the enumerated descriptions are exported, a certificate of their being natives of the island is to accompany them. On the vessel's return, another certificate is required, that the same identical number, and no more, have been landed.

There is, indeed, at present, little danger of the occurrence of that evil which the Jerseyman so much deprecates, as he will not speedily become a convert to any heretical opinions which he may happen to hear from an Englishman; for in this, as in every thing else, it may be observed, that the rooted opinions of a people are more powerful than any law.

The oxen are distinguished by rising to a stature and bulk much superior to the female. Persons who have not seen any other than Alderney cows, would be surprised to witness the size attained by some oxen of the same breed, which may be seen in the Jersey carts.

The object of the *dairy* is butter: the cows are milked thrice a day from the middle of April to the middle of July, and twice a day during the rest of the year; the milk is kept in glazed earthenware dishes till it throws up the cream, which is separated, kept five or six days, and then churned by itself. The prime milkers are not generally exported. After the young cow has borne a calf or two, it is sometimes significantly remarked, "*qu'elle est bonne pour l'Angleterre*;" and she goes to the cow-jobber.

As to the merits of the Jersey cows the reporter observes, if the palm can be contested with them by any, it will be by a breed little known in the south, the Dunlop (in Ayrshire) cattle, cross between the short-horned and the Alderney.

Sheep a bad-shouldered coarse-boned breed, small horned, and between a black and brown colour; largest flock in the island forty! weight of carcass fifty pounds; in the winter many perish from want, and many by dogs.

Horses a hardy small breed, very ill treated.

Swine, white, long-legged, flap-eared.

Geese are plucked alive, when the feathers begin to drop, as a measure of economy, and also to prevent the grazing-ground being injured. It is also thought a relief to the animal.

Pigeons. Here, as in France, the *Droit de Colombier* is attached to certain residences; but not exclusively, as appeared to be the case in France, to those held by a noble tenure.

Bees. The flavour of Jersey honey highly vaunted, probably from the numerous flowering plants, legumes, fruit-trees, garden plants left to seed, &c.

12. Political Economy.

Roads numerous, narrow, winding, crossing each other, and consequently intricate; flanked by high earthen fences over-canopied by trees. In rainy weather they are canals of mud. Two carts meeting each other on the *chemin du roi* could not pass; one or the other must back till it reached the nearest field, gateway, or some other recess, to which it might retreat during the passage of the other. To this little circumstance in their internal economy, and the disputes which it engendered, may, perhaps, in part, be attributed the remarkable proficiency of the Jersey populace in swearing.

Manufactures few: some boots, shoes, and cordage exported; an oyster fishery to the east of the island. English law as to poor-rates exists; but as the poor are few, it is not necessary to act on it. Dialect of Jersey a corrupted French, and a bad English.

7828. GUERNSEY. A rocky hilly surface, of which 8000 acres are under cultivation; the climate rather moister than that of Jersey, and the soil generally light, on granite, gneiss, or schistus. The operative classes resemble those of England more than those of Jersey.

Agriculture much the same as in Jersey; Guernsey figs much esteemed. Some land embanked and sold with permission of government, and the produce applied to improving the roads.

Live stock. Guernsey cattle are larger-boned, taller, in every respect more stout and coarsely made than those of Jersey. The front is wide, horns divergent and thick, but not long; never with the graceful short curve observed in some Jersey cattle, and in the short-horned breed. The dewlap is also coarse and pendant. They are deep-chested, and the carcass, compared with their neighbours, more bulky. Their coat is also not so fine: and the colours, though varying as in Jersey, on the whole appear more dark. Some, but not so many, are found cream-coloured, and the breed may safely be pronounced more stout and hardy. In one respect, a similarity appears in the best milkers in each island: these are observed to have a yellow circle round the eye; the hide yellowish; and, in particular, the skin of the tail at its extremity appears of a deep yellow, approaching an orange colour. The same circumstance has been since observed to exist in good milkers of other breeds; but in Guernsey at least, on examination, this yellowness is general and striking. The butter produced by the milk of each breed is also naturally of a rich yellow colour.

As to the question of superiority between the cattle of either island, it is settled most decidedly by the inhabitants of each, as may be supposed, in their own favour. The people of Jersey have gone furthest in support of their opinion. By the third

section of their law of 1789, respecting cattle, they expressly apply "*aux îles voisines*" the same penalties and restriction on importation of cows, heifers, and bulls, as on importation from any other quarter. Into Guernsey, where no similar restrictions exist, Jersey cows have occasionally been imported. The comparison between cows of each breed, as milkers, leads to that result which, in the place where it is made, might be anticipated.

Next it may be noticed, that though the exportation of Guernsey cows, compared with that of the same animals in Jersey, is not extensive; yet that their price in Guernsey is higher. One was noticed for which a farmer had offered a price of thirty guineas, for his own use, and had the offer refused. As to the quality of the butter also, in each island, it may be observed, that the preference is usually given to that of Guernsey. In this article, indeed, in some degree the difference may arise from their different practices in the process of churning. The cream is here left unskimmed, till the milk becomes coagulated: on the third day milk and cream are churned together. As little attention has yet been given to the improvement of the breed of cattle, as in Jersey.

Roads improved under the government of Sir John Doyle. Bricks and tiles manufactured, and some spirits distilled, which formerly found its way into England under the name of French brandy.

SECT. II. Agricultural Survey of Wales.

7829. A hilly mountainous surface of 5,206,900 acres, with a climate colder than that of England, and more moist in the proportion of thirty-four, the average number of the inches of rain which falls in Wales, to twenty-two, the number for England. The soil is generally of an inferior description, and the great proportion of mountainous surface is fit only for pasturage and planting. Little exertion was made in cultivation till the middle of the eighteenth century; from that period to the present agriculture has been gradually improving. A general view of it, as in 1809, has been published by the Rev. W. Davis of Montgomeryshire, whose work we shall adopt as our guide.

7830. NORTH WALES. 1,974,510 acres, chiefly of mountainous surface, in six counties, including the Isle of Anglesea. The climate humid and cold in elevated situations, but warmer in the vales and near the sea. The soil moory, coarse, clayey, and otherwise unfavourable in most places, excepting in the vales on the banks of streams. Minerals chiefly copper, lead, and iron. The famous Mona and Paris Copper mines in Anglesea have been worked since 1768; lead is chiefly worked in Flintshire. Excellent slate

is found in various parts of Caernarvonshire, and worked to a great extent, especially on Lord Penrhyn's estate. Marble is worked in Anglesea; and limestone, freestone, and other stones and minerals abound in different places.

1. *Property.*

Estates from thirty shillings to 50,000*l.* The effect of the custom of gavelkind, which prevailed all over Wales, was a too minute division of property. Equality and poverty went hand in hand. But when the custom was abolished, and alienation permitted, an accumulation of property was the necessary consequence, which became very prevalent in the two last centuries: and having arrived at its maximum early in the eighteenth century, it has, since that period, shown some instances of retrogradation: but subdivision and accumulation of estates will naturally fluctuate. Here are petty lairds or tacksmen, as in Scotland and Ireland.

Gentlemen of moderate income, and residing in the country, transact the affairs of their own estates. Those of greater property commit the whole care of rents, repairs, and contracts of sale or purchase, to the management of agents; who, in general, are persons well qualified for the undertaking, brought up solely to the business, and make it a point of honour and integrity to do justice to the landlord, and a point of conscience not to oppress the tenant. Some of the lawyer agents, having by their own indiscretion and rapacity destroyed the very *vis vite* of litigation in the people, necessarily diminished the number of their successors.

Only two copyhold tenements have been noticed in the whole district. All the other estates are held either mediately or immediately *in capite* of the king, by a kind of mixed tenure, between the feudal and allodial, going under the common appellation of freehold.

2. *Buildings.*

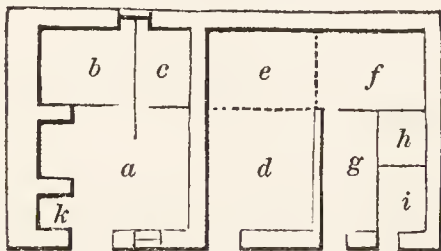
Some fine castles, as Powys, Penrhyn, and Chirk. Of farm-eries, about seven in ten are in a very wretched state; good new ones in Anglesea, and Caernarvonshire, Flintshire, and Merionethshire.

Cottages in these and other counties are truly the habitations of wretchedness. One smoky hearth (for it should not be styled a kitchen), and one damp litter-cell (for it cannot be called a bedroom), are frequently all the space allotted to a labourer, his wife, and four or five children. The consequences are obvious; filth, disease, and, frequently, premature death: and they would be more obvious, had not these evils an almost unshakable vigour of constitution to encounter. Three fourths of the victims of the putrid fever perish in the mephitic air of these dwellings. However, in some parts, especially near lime-works, mines, collieries, &c., the example of one neat cottager is followed by others. Here, their dwellings are frequently white-washed; their children are industrious in collecting road manure, which is preserved within circles of loose stones, for the use of their gardens. These minutiae, though trifling, are worthy of record, as they are descriptive of their general character.

Some exceptions in different places, and especially on Lord Penrhyn's estate. The reporter gives an excellent plan of a cottage for a cottage farm, and also plans of farms of different sizes, adapted to such cottages.

The *cottage farm-house* (fig. 1122.) contains a kitchen (*a*), bed-

1122



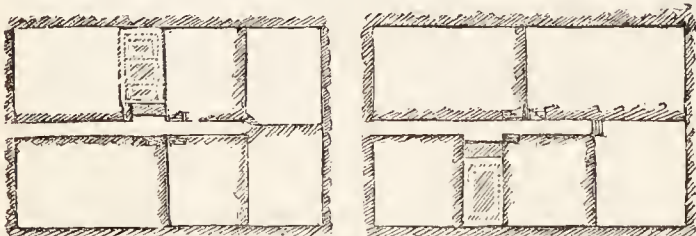
room or parlour (*b*), pantry (*c*), barn-floor (*d*), two bays (*e* and *f*), cow-house (*g*), calving place and calf-house (*h*), pigsty (*i*), and stairs (*k*) to garret and bedrooms.

One *cottage farm* for the same house, and nine acres of land, contains seven small enclosures (fig. 1123. *a*) including the garden. One for six acres, contains six enclosures (*b*) including the garden.

3. *Occupation.*

Largest farm of cultivatable land about 600 acres, on the mountains 1000 acres and upwards, at one shilling, or one shilling and sixpence per acre: size on the increase, and admitted to be favourable to wealth by the reporter, who adds, "yet that wealth should be valued, not in proportion to its national aggregate, or quantity in the abstract, but as it is

a 1123 b



widely and generally diffused. An analogy exists between monopoly in all its forms and a macrocephalous constitution, which never can possess the energy of a body symmetrically proportionate.

Farmers, properly so called, are, as we may naturally expect them to be, rather too tenacious of old customs. It is, however, illiberal to charge them with obstinacy, in delaying the adoption of pretended improvements; for, as it is not all gold that glitters, neither are one half of the patent implements and machines, nor one tenth of the writings of visionary theorists, better than lumber and trash; for which the farmer should not throw away his hard-earned money, before they are put to the test of experience, by those who have opulence enough to bear disappointment; and who, from the advantage

of superior education, may be better qualified to form a judgment of the probable effects. Show the farmers their true interest, and, in general, their minds are as open to conviction, and as susceptible to reason, as any other class of men whatever.

Leases out of repute. It cannot be denied that leases have done good in Scotland. We are, therefore, driven to the necessity of supposing, that the Scotch and Welsh tenantry are very different kinds of beings. The circumstance that renders the Welsh leases ineffectual, is the want of capital; and what enhances the evil of this want is, the ignorance of many farmers in the right application of what small capital they have. By tilling too many acres, they, as well as the public, suffer loss in every acre. Many a farmer, who has means barely sufficient to manage a farm of 50*l.* a year tolerably well, thinks a farm under 100*l.* or 150*l.* beneath his notice; and granting a lease to such a tenant, who has not one fourth of the capital requisite to carry on improvements, would be preposterous.

Lord Penrhyn executed draining, fences, roads, and all improvements requested by his tenants, and approved of by his agents, at five pounds per cent on their amount added to the rent.

4. *Implements.*

The original Welsh plough, a clumsy wooden fabric, still in use in Caernarvonshire, and a few places in other counties; about 1660, Lammas's variety of the Rotheram introduced, and now common; Scotch plough now generally known and approved; the other improved implements tried by the amateurs.

5. *Arable Land.*

"That farmers convert too much of the lands which were formerly in tillage, into pasture, is but a groundless cause of alarm. Farmers should, and always will, consult their own interests; and whether the conversion of their lands into tillage or into pasture be found the most profitable to themselves, the same will eventually be found most beneficial also to the public."

The corn raised in North Wales not equal to its consumption: falls general and defended as necessary. In Anglesea, a rotation of five white crops in succession; most of them barely return the expenses. Very little wheat grown, main corn-crop oats, and next barley. Scarcely any flax or hemp grown; potatoes beginning to become a general crop. On the whole, the management of arable land wretched, excepting by the amateurs or proprietors.

6. *Grass.*

Land well adapted for tillage; is commonly left too long in pasture; by which neglect it becomes mossy, and in some instances covered with ant-hills. It has been said of some meadow-lands in Wales, that a man may mow in them all day, and carry home his day's work at night. This may appear hyperbolic; but it is so far true, that in some meadows the mark of the swath never disappears; and a mower may be certain of having followed the same line, to a half-inch width, for twenty or any number of years back. In such meadows, the trouble of raking the hay together is the great work of harvest.

In the eastern parts of the counties of Denbigh, Flint, and Montgomery, consisting of the most fertile vales, the principal object of the farmers is to convert their hay and grass, as much as possible, into butter and cheese.

In the hilly parts of the afore-named counties, and in Anglesea, Caernarvon, and Merionydd, their peculiar province is to rear cattle, to be sold lean to the graziers of other districts. There are but few acres of land that will fatten cattle; the vales of the Severn and Vyrnwy in Monmouthshire, the banks of the Dee in Flintshire, and the vale of the Clwyd in Denbighshire, are the principal places where the pastures afford sufficient nutriment for that purpose.

7. *Gardens.*

Much wanted for the cottagers, especially in Caernarvon and Merionethshire. Too many poor cottagers have not as much as a leek or a potato, except what they either heg or buy. In the greater part of the district, the planting of orchards would be thought a very wrong application of the soil. On the borders of England are some orchards; and in plentiful years, a few farmers make either cider or perry for their own beverage.

8. *Woods.*

Have been abundant in former times, especially in Anglesea; now very scarce there and in Caernarvonshire; more in Denbighshire, especially round Chirk Castle, Wynnstay, Erthing, Vale of Clwyd, &c. Extensive young plantations made in these counties, especially at Wynnstay and Lord Penrhyn's. A great deal of wood; various young plantations in Merionethshire, and much timber, wood lands, and plantations in Montgomeryshire, which will long be the best wooded county in North Wales. Proprietors planting upon a large scale, and not raising trees from seed in their own nurseries, formerly used to procure seedlings of larch, firs, and pines, &c. from Scotland; but owing to their heating in close bundles, and otherwise damaging upon the road, not above one fourth, and frequently not above one eighth of the number could be expected to grow. They are now more given to encourage nurserymen at home, and nurseries are accordingly established in different parts of the district. "One and two year old seedlings of all sorts of forest trees, nearly as cheap as in Scotland, reckoning carriage, and one thousand worth two of theirs." This is true when the tenderness of seedlings, distance of carriage, and length of time, are considered. Williams, and other nurserymen, insure trees of their own growth and planting for a number of years.

9. *Improvements.*

A marsh of 5000 acres in the southern corner of the island of Anglesea attempted to be embanked in 1790. The embankment was brought forward from both sides at the same time, and was intended to be joined in the middle of the marsh, where the force of the tide was greatest; when within about twenty roods of a complete junction, owing to some of the proprietors withholding their dividends, the work was deserted, after expending nearly 12,000*l.*, and when a few pounds

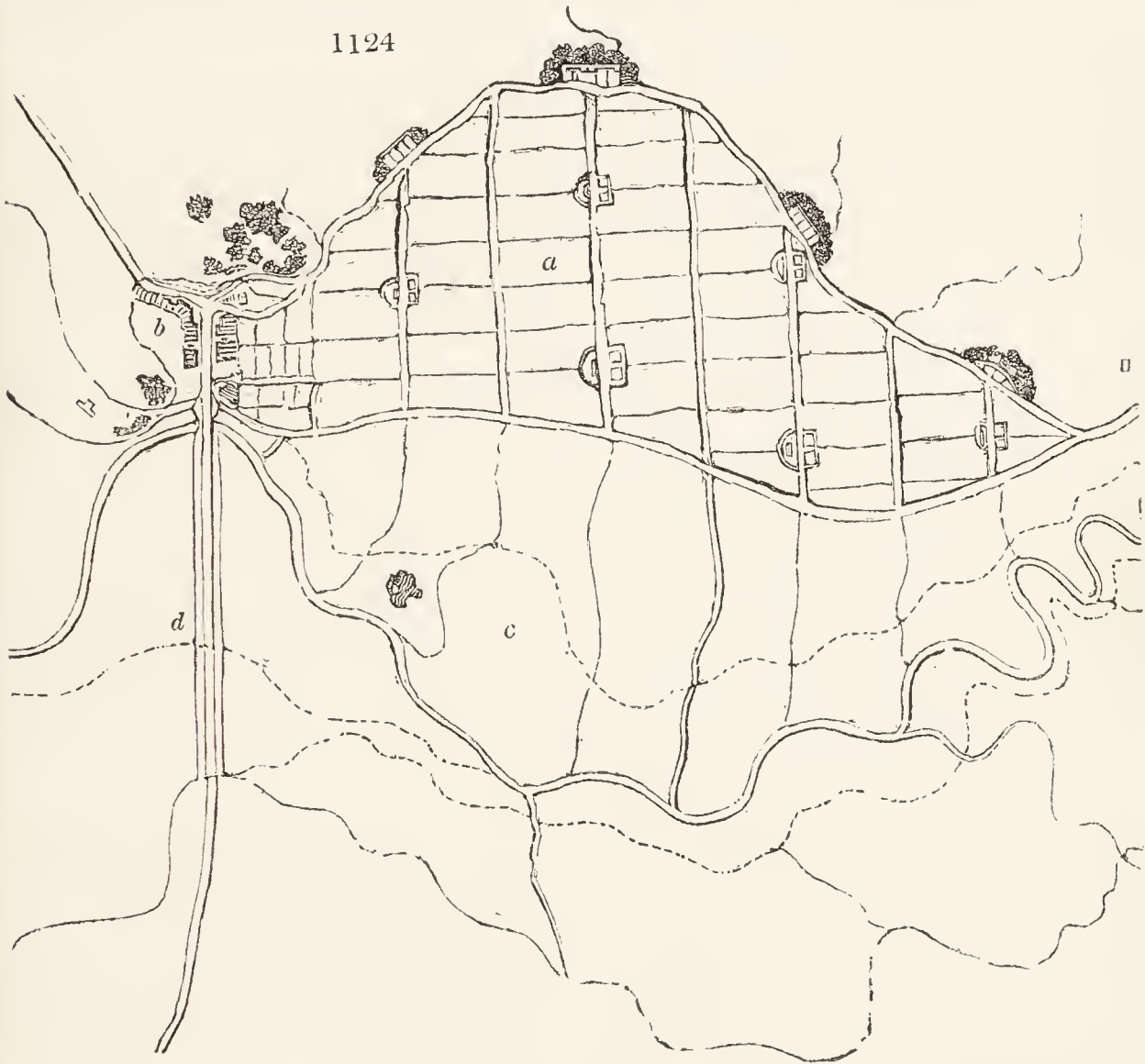
more would have completed the whole, as the materials were already carried on the spot. On the 25d of January, 1796, an uncommonly high tide added twenty roods more to the breach, in which state it now lies. The bank was made of furze faggots, bound with double cordage, covered with sand, then with sods, and on the sea-side with a stone pavement, eighteen inches deep at the top, and diminishing to nine inches at the bottom. It was fifty-one yards wide at the base, four yards at the summit, and five yards high; the slope of the sea-side to that of the land-side, as seven to four.

The *embankment and improvement of Traeth-Mawr and Traeth-Bychan sands*, between Caernarvon and Merioneth-shires, have been above 170 years in contemplation, and never yet performed. In 1625, Sir John Wynne, of Gwydir, intended to have brought over Sir Hugh Myddleton, the celebrated engineer, to undertake the work; but no materials were wasted, save ink and paper. In the year 1719, some Dutch adventurers made a proposal to the proprietors, but to no effect. In 1770, the late Bell Lloyd, Esq. who was always active in works of public utility, and others, brought the subject afresh under consideration; at the same time proposing a nearer road from London to Dublin, across the Traeth-Mawr sands, when embanked. Golborne, the engineer, was sent

down by the Duke of Ancaster, and two estimates were made. The late Dr. Worthington was peculiarly active in forwarding the work. He had gone so far as to procure subscriptions to the amount of 29,000*l.* and upwards, when the whole scheme was frustrated by the mean spirit and refractoriness of some neighbouring proprietors.

In 1809, W. A. Madocks, Esq. M.P., having a considerable estate on the Caernarvonshire side, and having there embanked Penmorva marsh with great profit (*fig. 1124. a*), and founded the village of Tremadoc (*b*), commenced embanking the sands of Traeth-Mawr (*c*), by carrying out from both shores an immense bank (*d*) of stony materials deposited and left to find their own slope by the washing of the tides. The two banks were within less than a furlong of being joined in the middle; but owing to the force of the tides, and the embarrassments of the very spirited proprietor, it was not completed before he was ruined. The persons, however, into whose hands the property fell brought it to a successful conclusion; and its proprietor, who had settled in the neighbourhood, and is lately dead, yet lived long enough to see realised by others all that he had anticipated, and for which he had sacrificed a very considerable fortune.

1124



The *River Dee Company*, established by Act of Parliament in 1740; by several embankments made in the years 1754, 1763, 1769, and 1790, on the river Dee, in Flintshire, to keep out the tide and land-floods, they have been enabled to gain 3100 acres, which are now covered with good crops of corn of lucern, and of artificial grasses; and the whole redeemed waste is incorporated into a township, bearing the very appropriate name of Sealand.

“In various parts of the coast of Anglesea, and the other maritime counties of North Wales, there is still much to be done by embanking. Caernarvonshire has been eminently fortunate in the acquisition of W. A. Madocks among its leading improvers. Indeed his improvements are of such magnitude and variety, designed with such taste, and executed with such facility, that a minute report of them would appear, to those who have not personally visited the place, more like the reveries of romance, than the narrative of genuine description. In harbours, embankments, canals, buildings, roads, plantations, and rural and commercial improvements in general, nothing less than a *Tremadoc Guide* pamphlet can do justice to the founder.”

10. *Live Stock.*

Cattle and copper the staple exports of Anglesea. When numerous herds are bought in the island for the English markets, they are compelled to swim in droves across the strait of the Menai; and although numbers of the weaker sort are sometimes swept down by the force of the current for some miles, yet losses seldom or never happen. A chain bridge has been thrown across this strait.

The characteristics of a choice Anglesea ox, must agree in most points with those of a Roman one, as described by Columella: coal-black colour, with white appendages; remarkably broad ribs; high and wide hips; deep chest; large dewlap; flat face; and long horns, turning upwards. Bakewell thought, that in some points they were nearer his idea of

perfection in shape, than any other he ever saw; his own improved breed excepted. Some farmers aspiring at a select stock, by having their he-calves gelt under their dams, their horns become of a yellower colour, longer, and finer than common; and, upon the whole, nearer the present idea of symmetry. The average weight of their quarters, when fat, at three or four years old, is from eight to eleven score pounds.

The promontory of Lleyn and Evionydd, in Caernarvonshire, having the same kind of undulated surface, though not altogether so good a soil as Anglesea, has likewise a breed of cattle similar in several of their characteristics.

The cattle in the remaining part of Caernarvonshire, and in the whole of the county of Meirionydd, some few select stocks excepted, seem to be diminutives of the above breeds of Anglesea, Lleyn, and Evionydd; having nothing to recommend them, save their extreme hardiness, and consequent cheapness of rearing. The highlands of the counties of Denbigh and Montgomery abound with the same puny race. In the vales, and in the county of Flint, the cattle are of a superior kind, larger, and of all varieties of colours. The natives of the sea-coast from Abergelen to Holywell, and thence along the Dee towards Cheshire, are reckoned very quick feeders.

Neither good butter nor cheese are made in North Wales by ordinary farmers.

Sheep. The largest of the native breeds is that of Anglesea; they have white legs and faces, and are generally without horns.

The second kind of sheep in North Wales is that peculiar to the mountains. They have generally white faces and legs; some have horns, and others none. The smaller sort of them weigh from seven to nine pounds per quarter; and give wool from three quarters of a pound to one pound and a half.

The third kind is peculiar to the Kerry hills in Montgomeryshire; being, perhaps, the only species in North Wales which produces perfect wool: that of every other Welsh

breed being more or less mixed with coarse long hairs, called by the manufacturers kemps, making the articles in which they appear of much less value. The characteristics of this breed are, large woolly cheeks, white hunchy foreheads, white legs covered with wool, no horns, and a broad beaver-like tail. They are very hardy, and comparatively tame; being not so much disposed to ramble as most other wild sheep. In shape, however, they are far short of compact symmetry; and were this defect improved by the care and attention of the farmers, the breed would be worthy of being universally adopted throughout the principality. They weigh, when fat, from ten to fourteen pounds per quarter. The average of wool, including the whole flock, is ten stone, of fifteen pounds each, from every 100 sheep.

The fourth kind is the black-faced and fine-wooled sheep, bred on the Long Mountain, near Welsh Pool; and on other hills, on the borders of England, in a line from thence to Wrexham.

The flavour of the mutton of the sheep feeding upon the Llanymyneich and Porthywaen lime-rocks is reckoned very delicious, by the nice-palated pupils of the Epicurean school; and their wool is as fine as any in England; that of the Ryeland breed, perhaps, excepted. A person in travelling through the country may observe several other kinds of sheep; being crosses from some or other of the above four distinct breeds; but they are in general the offspring of chance and instinct, without being directed by any choice or system.

The Merinos with their different crosses; the Leicester, Downs, and others, bred by amateurs.

Horses. In Anglesea, for want of fences, the horses, as well as the sheep, are commonly fettered. Were colts of the best-shaped breed in existence thus fettered as soon as they are weaned from their dams, and the practice used from generation to generation, their natural gait and shape must necessarily be changed, at length, into awkwardness and deformity. Few English stallions have as yet been introduced into the island; and those that have do not appear to have done much towards improving the native breed.

In the county of Meirionydd, and the hilly parts of Montgomeryshire, great numbers of ponies, commonly called merlins, are reared. They are exceedingly hardy, having, during winter as well as summer, only the range of the hills, from whence they are never brought down until they are three years old, and fit for sale. What has tended to, and will in time destroy, the shape and good qualities of this hardy race, is, that in the propagation of their species they are left entirely to chance and instinct.

They are driven from the hills to fairs, like flocks of wild sheep; and the place of sale exhibits, in some degree, an amphitheatre, where manhood and ponyhood strive for the victory. When a chapman has fixed upon his choice at a distance, the wrestler, being generally the seller's servant, rushes into the midst of the herd, and seizes the selected animal; which, never before touched by human hand, struggles with all its might to extricate itself; and in some particular situations, both have tumbled topsy-turvy from the summit of a steep hill down into a river beneath: the hiped still continuing his grasp, and the quadruped disdaining tamely to submit.

Another breed, somewhat larger than these, and probably raised by a series of crossing between the English and the natives, are hardy, handsome, and exceedingly active. Some of them are too small for the team; but for the road, under moderate weight, they have no rivals. "They will ascend and descend our mountainous staircases" with the greatest agility; and without giving their riders, who have more fool-hardiness than humanity, the trouble of alighting. The larger kind of them is exceedingly well adapted for the team, on small or steep mountainous farms; where the great strength and sluggishness of the heavy kind of horses would be egregiously misapplied.

The vales of Montgomeryshire have long been noted for an excellent breed. Some attribute this superiority to a stud of horses kept by Queen Elizabeth at Park, near Caer Sws, in the Severn vale, and to others brought into this part of the country from Spain by Robert Earl of Shrewsbury.

Gentlemen in most parts of the district, and farmers in the vales of the three counties bordering on England, have for some time furnished themselves with excellent draught horses, both for the coach and the waggon; which, when the markets are open, are sold in great numbers. They are generally either black or bay, strong, active, well made, and measure from fifteen to sixteen hands high.

A custom, very injurious to the growth, strength, and soundness of horses, prevails over the greatest part of the six counties; that is, working them too young, when their bones have not attained firmness from their cartilaginous state, nor their power of elasticity, contraction, and extension, which is necessary to endure exertion and labour. Instances have, however, occurred of horses being worked from two to twenty years old, without any apparent detriment saving a diminution of their natural size.

"The predilection which farmers manifest in favour of horse teams may, in time, reduce the nation to the dilemma of enacting a law to repeal the Mosaic law, and enjoin the flesh eatable."

Tender furze, bruised with mallets or ground in mills erected for the purpose, was formerly a great article of fodder in the counties of Anglesea and Caernarvon. Farmers were then accustomed to sow furze for their horses, and sometimes to let the crop at a certain price per acre, which was frequently found to pay better than a crop of wheat; but Ceres at length seems to

have grown ashamed of such husbandry, and the lands are in general converted to bear more useful crops.

Hogs. The original Welsh breed had small ears, which, probably by a cross with the Berkshires, produced the slouch-eared hogs, which were lately general through the country. They are slow feeders, and the rearing of them is now upon the decline, and giving place to that of more improved breeds, especially Berkshire.

Bees. "The ancient Welsh held these industrious insects in great veneration, and believed them to be of Paradisiacal origin." (*Wotton's Leges Wallicæ*, p. 254.) For this reason their priests taught that the chanting of mass was not acceptable to the Deity unless the lighted tapers were made of their wax. Out of their dulcet stores they brewed their national liquor, metheglin, or the medicinal beverage.

When the country was almost one continued wilderness, almost every hollow oak was an apiary. Their nests on the wastes were the property of the lords of the soil, and rented by some of their vassals. On freehold lands they were claimed by the respective proprietors. The discoverer of a swarm was entitled by law to a reward of one penny, if they were domesticated bees; and one penny and a dinner, or in lieu of these the whole of the wax, if they were of the wild race. Whoever cut a tree upon another person's property, in order to get at the nest of bees, was to be amerced the full value of both tree and bees. The respective prices of different swarms were ascertained by law.

Early swarms were reckoned of full value by the first of August; such as swarmed after that day were not valued above fourpence until the following May.

In comparison with the prices of other articles at the time the Welsh laws were framed, bees seem to have been very dear, and consequently scarce; but the price set upon them by law was much above the real price in commerce between buyer and seller. This was owing to the veneration they were held in by the legislature, and intended to deter the subject from offending against the statutes made to preserve them. As a confirmation of this opinion, every thing that belonged to bees had its value exaggerated in law; even a bee-hive was appraised at two shillings, when a new plough without irons was valued only at twopence, a cow forty-eight pence, a yearling calf fourteen pence, and a suckling calf one penny.

The sacred esteem in which bees were held at length declining, apiaries were gradually reduced to their present fewness of number. However, several persons still execrate the profane act of disposing of their bees for money; but will nevertheless let them out for one half share of the honey and wax when they are killed annually in autumn, and the whole live stock to be parted equally between them at the end of the fourth year.

In Wales, as in Poland, when spirits and beer became more common, the use of metheglin declined, and bees were neglected. Hence it may be inferred, that the veneration in which this insect was held in these and other countries was owing to its affording almost the only, and at all events the cheapest and most powerful, means of indulging in that which man, in all ages and countries, has considered the *summum bonum* of enjoyment — intoxication; an enjoyment which, whether, with Noah, it be procured legitimately from that "transcendent liquor" wine; with the American Indians, from eiver; or, with the Turks, from opium, has these advantages over all others, that it is more immediate and more intense; that it is within the reach of every one; that every one can have it to the full; and that for the enjoyment of it no man is envied by his neighbour.

11. Political Economy.

Great improvements have been made in the roads and bridges of late years, especially by Lord Penrhyn, Wynn, Madocks, and government, under the direction of Telford. Previously to the year 1785, the annual export of slates from Lord Penrhyn's quarries at Dolawen did not exceed 1000 tons; which, owing to the ruggedness of the road, were conveyed from the quarries to the port, a distance of six miles, in panniers on horses' backs. His lordship formed a new road, which gave immediate employ to about 120 broad-wheeled carts and waggons; and from the quarries he extended the road nine miles further to Capel Craig, through Nantffranco and the romantic interior of Snowdon, at his own expense, the whole tract being his property. The increase of the slate trade caused his lordship afterwards to have an iron railway, the length of six miles, from Dolawen quarries to Port Penrhyn.

The chain bridge erected across the Menai by Telford is one of the most extraordinary works of the kind in existence.

Of canals there are several, with stupendous aqueducts and bridges. The aqueduct of the Ellesmere canal, thrown over the Dee, is the first in Europe. It was opened in November 1805.

Manufactures chiefly blue cloth, blankets, flannels, and Welsh plains or cottons. The best Welsh flannels manufactured in Montgomeryshire. Welsh flannels made since the time of James the First have the warp of fleece wool, and the woof a mixture of one third or one half of Welsh wool. Knitting stockings and caps very general among the females of cottages and small farms. Argillaceous schistus is converted into slates for the roofing of houses and other purposes, to a very great amount within this district.

Pyroligneous acid extracted from brushwood, at Hope in Flintshire, for the use of cotton dyers. A variety of other manufactures to a moderate extent. Several agricultural societies.

7831. SOUTH WALES. Six counties, and some islets, comprising together 2,470,400 acres of hilly and mountainous surface; generally of a salubrious climate; cold on the mountains; but, on the whole, more temperate than the air of North Wales. The soil argillaceous red loam, or calcareous, but generally rich in the vales and declivities. Of minerals there is abundance of iron, coal, lime, and a good deal of lead.

1. Property and Buildings.

As in North Wales. In South Wales the custom of white-washing cottages is prevalent. In Glamorganshire, not only the inside and outside of houses, but barns and stables also, walls of yards and gardens, the stone banks of quickset hedges, and even solitary stones of large dimensions, house

blocks, &c. near the houses, are white-washed. This practice is traced to a very remote antiquity. Diodorus Siculus is quoted as mentioning the British custom of white-washing houses. Gentlemen's seats are distinguishable from cottages, not only by their size and plans, but also by their colours. In Glamorganshire gentlemen mix ochre with lime, to make their

seats of Isabella yellow. In the north of Pembrokeshire, &c. the taste is reversed; the cottages are of a very dingy colour, and gentlemen's houses are white-washed; the maxim is—not to be what the lower classes are; not to coincide with the vulgar in their practices.

2. Occupation.

Farms of all sizes; two mountain farms of 1400 acres each; general run from thirty to one hundred acres; average of the district between fifty and sixty acres. In the uplands rearing of stock is the main object, without neglecting the produce of the dairy; whilst they find convenience, though without profit, in a scanty and precarious tillage. In the lowlands, or moist loams, especially in the more humid climate of the western counties, grazing is considered, and generally recommended, as the most profitable.

Upon an average of the whole, the district may be said to be occupied in that kind of system called mixed husbandry; breeding, dairying, and tillage; varying in the proportion of each in different places, according to the imperiousness of existing circumstances, which will be hereafter more fully explained.

Farmers may be classed as proprietors farming a part of their own estates, small proprietors or yeomen, farmers of the old school, and book-farmers.

"Book-farmers, the aerialists of Marshal, are those who know agriculture only by reading about it. Theory is their *ne plus ultra*, as they generally grow tired before they are much acquainted with practice. The practice of the country they come to reside in is all wrong, and the inhabitants all savages. They bring ploughs and ploughmen generally from a distance; and when the masters retire, the ploughmen return and the ploughs are laid aside. They hold the farmers of the old school, as they call them, in sovereign contempt; who in return deride their puerilities, and, in their own quaint phrase, style their ineffectual attempts to establish a system of improved agriculture '*a flash in the pan*.' They do considerable good in the vicinity they dwell in by employing labourers; and by their imported implements they open the eyes of mechanics. Most of the harm they do is to themselves. They injure others mostly by an exorbitant advance in the wages of servants, especially of such as pretend to be farm bailiffs. They give double the wages that the old established farmers in the best cultivated counties, Salop or Hereford, &c. will give. They have generally very exalted notions of the value of land, and the powers of soil. They read of the high returns of crops in England or elsewhere, and calculate there upon the value of land in the uplands of Wales; which, if they have farms to let, makes it extremely difficult to deal with them. Their opinion of manure depends on the book they have read last. If Jethro Tull is their favourite author, soil requires nothing but ploughing and stirring. With *A. lime is every thing*; with his brother B., only a few miles distant, and on the same kind of soil, *lime is nothing*."

3. Implements.

The Welsh plough is in common use; and perhaps a more awkward, unmeaning tool is not to be found in any civilised country. It is not calculated to cut a furrow, but to tear it open by main force. The share is like a large wedge; the coulter comes before the point of the share sometimes, and sometimes stands above it; the earth-board is a thing never thought of, but a stick (a hedge-stake or any thing) is fastened from the right side of the heel of the share, and extends to the hind part of the plough: this is intended to turn the furrow, which it sometimes performs, and sometimes not; so that a field ploughed with this machine looks as if a drove of swine had been mowing it.

The Rotheram and other improved ploughs are in use among the proprietor and book-farmers, and the Scotch plough is coming into very general use. A gentleman, a naval officer, in Cardiganshire, introduced the light Rotheram, and insisted on his ploughmen using them. As soon as he turned his back, the new ploughs were dismissed the service, and the old ones brought into the field. One day, in a rage, he committed the old to the flames, and set the new ploughs a-going. Afterwards taking a ride to cool himself, and returning, he found the new ploughs in the ditch, and old ploughs borrowed from the neighbours at work: the master then thinking it useless to persevere, gave up the contest. "I have," said he, "seen various kinds of human beings, in different parts of the globe, from latitude ten to latitude fifty-four, but none so obstinately bent on old practices as the Welsh."

H. Lewis, Esq., of Gall y Gog near Caermarthen, being equally unsuccessful in effecting a revolution at once, tried the plan of altering the old ploughs in a slight degree, and hopes, by one alteration after another, at length to transform them into Rotheram ploughs "unawares to his sturdy ploughmen."

Waggons and clumsy two and three horse carts are in general use; almost every farmer of forty pounds a year rent has a waggon. Single horse carts gain ground but slowly. They were introduced into the vale of Towy, several years ago, by Lord Robert Seymour; into Cardiganshire, by the late Thomas Johnes, Esq.; and into Brecknockshire, by Sir Edward Hamilton.

A hay rake, with the head forming unequal angles with the handles, is in use in Glamorganshire, the only advantage of which is said to be that of not obliging the raker to step his foot backward at every reach.

4. Arable Land.

In general wretchedly managed, especially the fallows. The reporter proposes to send farmers' sons to improved districts to serve apprenticeships, as better than examples set by strangers, which have been tried without success. A patriotic land proprietor brought what were considered as enlightened farmers from Scotland into South Wales; but as Hassel very judiciously observes, "New practices in husbandry will be most likely to succeed through the medium of the natives of the country. They have an unconquerable dislike to every thing introduced by strangers; and not without some reason, as most of the people who have come into this country from the English counties, and commenced farmers, were in bad circumstances at the outset, and therefore have not succeeded in their undertakings; and the natives, eager to reprobate any thing new, readily attributed their failure to defective practice, rather than to the real cause, want of capital. This observation will be found to be generally true in every country. Few persons in good circumstances can be tempted to migrate; whilst others

of a different description are frequently under the necessity of doing it; and, generally, it can only tend to hasten their total failure. Then the teaching of the natives, as recommended above, would have a much superior effect in establishing the doctrines of the new schools, than the introduction of any strangers into the country.

The sand banks checking the progress of the tides into a flat tract in Glamorganshire, in order to render them more firm, they are matted with the roots of the sea mat-weed (*Arundo arenaria*). The Hon. T. Mansell Talbot binds each of his tenants, who rents land in the adjoining marshes, to give yearly the labour of a day or more, in proportion to his holding, as a kind of statute duty, for the planting of this reed; and experience has proved its good effects.

5. Grass.

By a correct map of the rivers of a district, with a scale of their fall in a given number of furlongs or miles, and of the mountains from which they flow, and those distinguished by kinds of "quality colours," a geologist might give a fair estimate of the quality of the soils and grasses of the respective valleys intersecting that district, though anomalies frequently form exceptions in valleys as well as on sideland places.

The practice of fogging pastures, almost peculiar to Cardiganshire, has been already described. (5837.) The reporter saw a piece that had been fogged successively for sixteen years; and according to the tenant's information, was improving annually. When land has been mowed too long, one year's fogging is supposed to recover it. Mossy pastures are benefited by it. It replenishes the soil with seeds, that by this means are suffered to ripen and shed on the ground; and it is said that two years' fogging will recover lands, let them be ever so run out by tillage or mowing. Cattle used to fog will quit hay that may be given them, and clear away the snow with their feet to get at the fog. The fields proper to be kept in fog must be of a dry, sound, and close soil; the argillaceous rather than the siliceous earths should prevail in it: but not so much as to be over-retentive of water.

The late Thomas Johnes, Esq., of Hafod, observes, "Fogging is getting out of repute: it must have originated in chance, and want of a summer stock of cattle."

Clover is grown in some few places for seed, which is separated from the heads in a common corn mill, the upper millstone being replaced for a time with a square piece of oak furnished with eight wings studded with nails on their upper surfaces. These spokes, by their rapid motion, soon beat out the seed.

8. Gardens.

On the maritime coast of South Wales generally very productive; those of the cottagers better attended to than in other parts of the district; a pleasing mixture of flowers, small fruits, and vegetables.

Orchards in Radnorshire and Brecknockshire thrive well in the valleys, but more especially in the vales of Wye and Usk. Not much cider made, except on the Wye.

7. Woods and Plantations.

"It appears from old deeds, that estates were formerly sold at an inferior price, in consequence of their being crowded with timber. Times are now changed."

There are a great many oak woods and coppices in hilly parts of the district, and many thriving plantations in every part of it. It is calculated that at an average six millions of trees are annually planted; if this be the fact, it is probable nine tenths of them either die or are doomed to come to nothing; for at this rate, in fifty years, there would be 150 trees for every acre in South Wales, which, added to the old wood and copse, would give 300 trees, or enough to render the country one entire forest.

8. Improvements.

Numerous enclosures have been made, and fencing, draining, and, in some cases, watering practised as in other counties. There are nearly 15,000 acres of fen and sands on the coast of Cardiganshire, which are considered highly improvable, and which it has been at different times in contemplation to embank. Of one of the worst parts of this land, the late agriculturist Dr. Anderson, who was much with Johnes of Hafod, said he could make it carry wheat in five years.

9. Live Stock.

From ancient records it appears that the colours of Welsh cattle were white, with red ears, like the wild breed at Chillingham (6804.); they appear to have been in a wild state so late as the time of king John. The present stock are of four kinds: the coal-blacks of Pembrokeshire; the brownish blacks, or dark browns, of Glamorgan; the black runts of Cardiganshire, Caermarthenshire, and the western parts of the counties of Brecon and Radnor; introduced breeds, from Herefordshire and Shropshire, into the eastern and more fertile parts of Brecon and Radnor.

Cows are kept for breeding, and making butter and skim-milk cheese. Johnes has proved, that at Hafod cheese may be made at will so nearly resembling Parmesan, Stilton, Gloucester, or Cheshire, that the difference cannot be perceived by good judges; and that the whole mystery consists in various modes of producing it from the milk.

The sheep of South Wales are of four kinds: mountaineers, Glamorgan vale sheep, Glamorgan Down sheep, and crossed and intermixed breeds.

Mountaineers occupy the hills in the several counties of the district.

The Glamorgan vale sheep is the only breed in Wales, not introduced within memory of man, that produces combing wool.

The Glamorgan Down sheep is a beautiful and excellent small breed. Feeding upon the oldest and sweetest pastures of the limestone tract, their mutton is superior in quality to most, and inferior to none; their wool is of the short clothing kind, and fine. They are generally polled.

With crossed and intermixed breeds many experiments have been tried within the district, and most of them confessedly without the expected success. Particular breeds of sheep have their peculiar diseases, which continue in their constitution, wherever they are removed. The limestone tract may be considered as the healthiest for sheep within the district, but even there the imported modern breeds have brought with them the scab, the foot-rot, the goggles, maggots, and a long train

of diseases never heard of before in Wales; these are to be ranked among the profits of commerce.

Horses. The small Welsh merlins or palfreys are now in many parts nearly extinct: they are a pigmy race, and may now and then be found in the hilly walks of the interior of the district. There were formerly a very good breed of hardy strong punches, fit for riding and walking upon the farm, being a cross between a good-sized horse and the small merlins; and very useful they were; but the breed has almost been totally neglected and lost: for they cross now too much with the large and sluggish cart-horses.

10. Political Economy.

Roads as in North Wales, or worse. Road ploughs in use; a characteristic both of their state and of the nature of the materials. Good limestone, however, in the coal districts, and especially in Glamorganshire. Manufactures of woollen in many places; and, owing to the abundance of oak copes, many hides tanned. Potteries on a large scale at Swansea, Cardiff, and other places. Extensive iron and coal works, lime works, and a slate quarry in Cardiganshire, &c.

The *Lias limestone*, (lime and iron combined, the stone of a bluish or greyish colour,) though found in many parts of

England, is nowhere so valuable as that at Aberthaw. When burnt into lime, it is of a buff colour, the characteristic, according to the engineer Smeaton, of all limes setting in water. *Lias limestone* in all parts has a peculiarity of stratification and exterior character, so that a rock of it may be known at a distance. The strata are of various thickness, from a few inches to a few feet; and those commonly separated by a few inches' thickness of marley clay. The ferruginous ingredient seems to be concentrated in the interior part of each stratum; the outer sides thereof being more porous, and of a paler colour. In inland places the strata are burnt altogether, the argillaceous as well as the ferruginous calcite. Here, at Aberthaw, or other maritime coasts, the strata tumbled down, within reach of the tides, are broken and rolled about, until they are reduced to rounded pebbles or nodules, from a few ounces to many pounds weight; and these consist only of the nucleus or kernel part, the more useless shell being worn off by the abrasion of the furious tides. These rounded *lias pebbles* are driven on shore in inexhaustible quantities.

Of *agricultural societies* there are several; that of Brecon instituted in 1755, the earliest in Britain after that of Edinburgh.

SECT. III. Agricultural Survey of Scotland.

7832. *The surface of this country is estimated at 18,944,000 acres, in three natural divisions. The first lies north of the chain of Highland lakes, which stretches from Murray to Mull, and consists of little else than dreary mountains and some moors: the second, or middle division, extends from this chain of lakes to the rivers Forth and Clyde; it is mountainous, but cultivated in the valleys, and on the eastern shore to a considerable extent: the remaining division is covered by hills with some mountains, but almost every where cultivated or improvable, and highly favourable for most branches of agriculture. Though Scotland, as elsewhere observed (770.), was far behind England in cultivation till the middle of the last century, it has now greatly outstripped that country, especially in arable husbandry; a proof that this is the general opinion of enlightened men may be deduced from the notices just given of the English and Welsh counties, in which it appears that the improvements introduced or attempted to be introduced on arable land are, with few exceptions, the implements and practices of Scotland. In the management of meadows or old pasture, Scotland cannot be conspicuous; as the climate is not naturally calculated for that kind of husbandry. The winters are too long and severe, and the surface too irregular. In regard to live stock, the palm of improvement was till lately borne away by England; but though there is not that enthusiasm in Scotland, nor such large prices given for capital specimens, it may be safely asserted that breeding and feeding are conducted as systematically and successfully there as in England. We shall glance at the different counties in the order of their proximity, beginning with that containing the capital. It may be sufficient to mention here that leases are universal in Scotland, generally for nineteen years, often for twenty-one, sometimes for fourteen, but seldom for a shorter period. The poor are supported by voluntary contributions at the church doors; though an assessment on property, half paid by the proprietors and half by the tenants, may be made if necessary, which is not generally the case. Assessments for the poor are common in the border counties and the Lothians, and occasional assessments, imposed upon the same principle, are resorted to in most of the other counties. Voluntary contributions are found inadequate, except in the most thinly-peopled districts. It is therefore a great though common mistake in England, to suppose that there are no poor-rates in Scotland; but they are comparatively moderate, and will likely continue so while the power of assessment remains with those (the landed proprietors) who have to bear an equal share of the burden with their tenants. It is here that an essential distinction exists between the poor-laws of England and Scotland. Tithes were commuted for their value in land and land's produce at an early period. Every parish has a schoolmaster, who is paid jointly by the proprietors and the farmers. There is a professorship of agriculture in the Edinburgh University, ably filled by Dr. Coventry, a man of whom it may be truly said, that he is universally esteemed and beloved. The best account of the agriculture of the Scotch counties is to be found in Black's edition of the *Encyc. Brit.* Edinburgh, 4to, 1829.*

7833. **MIDLOTHIAN, or EDINBURGHSHIRE,** contains 230,400 acres; one third hilly and inaccessible to the plough, and two thirds in tillage, pasture, or wood. The store sheep farming is practised on the hills, and a mixed agriculture on the low grounds. Green crops and potatoes are extensively cultivated for the Edinburgh market, and most farmers are more indebted to the manure they receive in return, than to the soil, or their superior skill: many of them are townsmen, amateurs, and speculative cultivators. The Dalkeith Farmers' Society, one of the most useful that has been formed, and which still exists, belongs to this county; and in it also was founded the British Wool Society, now extinct. A variety of interesting information respecting the progress of improvements in this county, and in East and West Lothian, will be found in *Rural Recollections*, 8vo, 1829, by George Robertson, author of several county surveys, and whose personal knowledge extends from 1765 to the present time. (*Robertson's Survey*, 1795. *Edin. Gaz. abridged*, 1829.)

1. Geographical State and Circumstances.

Climate free from extreme heats or colds; snow seldom falls on the low parts of the country before December, lies from three to ten weeks. In eight years, the greatest quantity of rain that fell in any year was 36.8 inches, and the least quantity 9.6 inches.

Soil much diversified; lands hanging to the north always the most fertile.

Minerals. A bed of coal extends across the county from S. W. to N. E. from seven to eight miles in breadth; worked for two centuries. Limestone, freestone, granite, and whinstone very abundant. Millstones in the parish of Pennycook, also marble. Some copper and iron ore, marl, and jasper pebbles on Arthur-seat.

Water. Streams inconsiderable. Esk (*Usk*, Gael.) the largest river; few fish from the rivers or streams, but abundance from the firth or sea.

2. Property.

About 540 estates in the county, divided by the reporter into seven classes; first class from $\frac{1}{2}$ to 5000*l.* or upwards; fifth class 100*l.* and upwards; sixth class, least properties; seventh class, properties of corporate bodies. Total rental in 1795, 191,000*l.*; Duke of Buccleugh the first proprietor.

3. Buildings.

Many gentlemen's seats, and some fine ruins of castles and religious houses.

A *farmer's mains*, as it is here called, consisted formerly of a set of low buildings, in the form of a square; one side was occupied by the master himself, whose habitation was composed of two or three dismal apartments, on an earthen floor, having a low ceiling and a few diminutive lights. On another side stood the barn, in which the roof timbers, from the idea of giving

more strength, were built into the wall from the foundation; the wall itself not being more than five feet in height. Opposite to the barn were the stables and the byre, or cow-house. The stables were totally without division, and the horses fed in common; but the neat-cattle, less passive, were each confined to their stables. The cottages occupied the remaining side; in the midst of all lay the dunghill. These buildings were made of turf and stone alternately, or with stone, and clay for mortar: the roof of thatch, or of thatch and *di. ot* (turf or sods) intermixed. Further details on this subject will be found in *Robertson's Rural Recollections*, p. 70.

Farmeries now in the first style of commodiousness. An example given of Gogarbank farm.

Cottages formerly very mean, now much improved. Robertson, in his *Recollections*, gives a figure of a modern Lothian cottage in its last stage of refinement, which is by no means inviting.

Farms vary from 100 to 500 acres. Farmers divided into three classes; speculators, converts from other professions; industrious laborers who have acquired some property; and farmers sprung from farmers.

Speculators. "In the immediate vicinity of the town, the greater part of the lands are cultivated, not by actual farmers, but what may be more properly termed speculators in agriculture, people with whom farming is but a secondary object; their chief employment being still what was their original profession, as bakers, brewers, innkeepers, or some other distinct occupation; and who are oftener to be found in their town lodgings, or in their counting-houses, than in the midst of their farms, attending to the operations of husbandry. One certain effect, which the speculations of this class produce, is, that the rent of land is raised above its natural level; for, as they have always some other business to live by, they are

enabled to afford more rent; and in fact give more than an actual farmer, whose sole dependence is upon husbandry, is able to pay; while their exertions in agriculture, though in general founded on good principles, commonly end in disappointment to themselves, for want of that unceasing attention which is indispensable to good cultivation, but which their other avocations prevent them from bestowing."

The *moor-land farmers*, as if in conformity to the soil, which has undergone very little melioration, and to the climate, which is naturally severe, seem still to retain a strong cast of the manners of their forefathers, and to live and toil under the same uncomfortable circumstances. Their houses are damp, smoky, and diminutive; their fare simple and limited; and their labours hard and even oppressive. But they have days of relaxation, in which they enjoy themselves at fairs and markets; their marriage festivities are almost boundless, and their funerals are pompous and ostentatious. Religion is maintained in all the austerity of Oliver Cromwell and the covenant.

These farmers are the only ones in a county containing a capital town, who are likely to better their condition. Being inured to the practice of the most rigid economy, they will, when translated to a warmer climate and more genial soil, very forcibly feel a melioration in their circumstances; and if they have fortitude enough (as the first race of them generally will) to persevere in their original habits of frugality, they may, by dint of mere saving, at the rate, perhaps, of two and a half per cent yearly on their capital, accumulate, in a lifetime, a sum that may be esteemed considerable. But this thriving state will only last during the first generation. Their sons habituated in time to an easier mode of life, will, amid the great luxury with which they are surrounded, lose their primitive simplicity of manners, and with it the faculty of saving, on which alone their prosperity depends.

4. Implements.

Old Scotch plough, long and heavy, and drawn by four or six horses or oxen, and till about 1768, when Drs. Grieve and Carlisle, clergymen, tried wheel ploughs of a lighter construction, which they had seen in use in Dalkeith Park. Soon afterwards Small's improved plough came into notice. Robertson mentions that the older race of farmers were very generally their own plough-wrights, and makers of their own implements of husbandry, with very little assistance from the professional mechanic. These implements were indeed made in a very clumsy manner, but otherwise strong and handy enough. They had all of them a set of wright's tools for the purpose. (*Rural Recollections*, p. 84.) The late Mr. Thomas Shiells, at Grothill, near Edinburgh, made with his own hands the first winnowing machine used in the Lothians, from a model of one imported from Holland. (*Ibid.* 148.)

5. Enclosing.

No commons or common-fields. Hedges first planted about 1760.

6. Arable Land.

When ridges are raised high, they should not be laid south and north, as the crop on the east side of such ridge is commonly found very defective. The same thing holds in the county of Lancaster.

7. Grass.

Very little permanent grass exclusive of the hills and moorlands. Alluvial lands on the banks of streams so liable to immense floods, bringing down soil, &c. that if in grass it would often be much injured; considered therefore more profitable to keep them in corn. There is some very productive meadow land near Edinburgh, irrigated by the water which flows from town, carrying along with it night-soil, &c. The produce of twelve or fifteen acres of this meadow sold in 1826 at an average of 42*l.* per acre; part of it reached nearly 60*l.*, the purchaser cutting and carrying it off, and incurring all other charges. This, of course, is only for one summer, but it will yield four or five cuttings during that season, or rather between the end of spring and the beginning of winter.

8. Gardens and Orchards.

Henry Prentice, who died about 1786, was the first who cultivated white peas, potatoes, turnips, and sundry other culinary plants, on an extensive scale, for the Edinburgh market, about the year 1746. Before that period, the supply was limited to what could be carried in baskets; his cart being the first that appeared with kitchen stuff in the streets. He even raised cucumbers in the fields; but his cart-load of these met with so little sale, as not to encourage a repetition. Though he died a pensioner on the poor's funds of the Canongate, his name deserves to be noticed with respect, not only as having introduced several of our best vegetables into cultivation, but from his practice as a cultivator, which was spirited and judicious, however little it turned out to his own account.

Strawberries About 200 acres on the banks of the Esk, and chiefly near Roslin. Crop continued on the same ground without end; but digging down and replanting every fourth year. To change every twenty or thirty years esteemed a better practice. Lands in nursery 200 acres. Mawer's hothouses at Dalry, and hotwalls of his invention, figured and described. The hothouses heated by steam. Mawer was a Lancashire man, and formerly gardener and steward to the Earl of Aberdeen. He was an excellent gardener and farmer; a man of very general information, and highly respected. He was extensively employed as a layer out of gardens and roads, and had the general charge of the gardening and tree department on some gentlemen's estates. The compiler of this Encyclopædia was his pupil, amanuensis, and draughtsman for the three years preceding his death, which happened suddenly from apoplexy in 1800.

9. Woods and Plantations.

About 5000 acres so occupied, the greatest part artificial, and planted since 1750. Hedgerow trees never come to any thing for want of shelter; belts do no good unless twenty rows thick at least.

10. Wastes.

None: but extensive tracts very poor.

11. Improvements.

Draining well understood and extensively practised. Johnston, who wrote an account of Elkington's mode of draining, a native of the county. Edinburgh and Leith afford about 40,000 cubic yards of street dung annually, which is commonly laid on the lands within five miles of town. Horse dung, however, carried twelve miles or further.

More need for weeding on the arable lands of this county than in those of any other in Scotland; supposed from more town manure being used. The town manure contains the seeds brought in from the country in hay and straw, which are of various kinds; but chiefly wild mustard, wild radish, dock, thistle, poppy, couch-grass, &c.

12. Live Stock.

Little attention was formerly paid to this department; but it is now conducted on improved principles. A great many cows are kept in Edinburgh, and well kept as well as judiciously selected. See the art. *Dairy* in *Sup. to Ency. Brit.* art. *Agriculture*. Galloway and Ayrshire cows preferred, and Clydesdale horses. Some buffaloes of the Mysore variety introduced by Col. Murray: not supposed to turn to any advantage, either as milkers, or for work, or the butcher, but form a variety in parks. Lord Morton subsequently introduced the quagga (*Equus Quagga*) on his park at Morton Hall for the same purpose. Bees a very popular species of live stock with all classes.

13. Rural Economy.

Well supplied with work-people from the highlands and Ireland. With the exception of some farm servants in the immediate vicinity of Edinburgh, they are, in general, orderly and moral. Children taught in the parish schools; reading at one shilling and four-pence, writing and arithmetic at two shillings and sixpence per quarter; Latin, &c. in proportion. The cottages of ploughmen consist generally of two rooms on the ground floor, with a pigstye, and 100 square yards, or upwards, of garden ground. The furniture consists of two beds, a few chairs or stools, table, chest of drawers, clothes-press, &c.; and they are all ambitious of having a time-piece, if it were only a cuckoo clock. The whole may be worth from ten to twelve pounds. The Sunday's dress of a young ploughman consists generally of a coat of blue cloth, at five shillings and sixpence the yard; velveret vest, corduroy breeches, white cotton stockings, calf-skin shoes with black silk shoe-knots, shirt with ruffles at the breast, white muslin fringed cravat, and a hat worth eight or ten shillings. The shoe-knots and ruffles are, indeed, rather uncommon, but all the other articles are very much in use. They make a very good appearance, and even pay attention to the fashion. In their food they still live in much the same simple way as their forefathers. Oatmeal forms the basis, or principal part of their sustenance. They have it regularly to breakfast and to supper, made into pottage, which they eat with a small allowance of butter-milk. At dinner they eat it in bread, in addition to their kale, a kind of soup made of barley-broth, intermixed with greens and pot-herbs. To this they add at times potatoes, and fish of different kinds; seldom wheat bread, and still more rarely butcher's meat. This mode of living, in which, although with no great variety, there is always abundance of food, seems to be very conformable to the natural constitution of the people, as they are found to go through their labour without feeling themselves oppressed, and enjoy a state of health which is very seldom interrupted. At an average, they are not above two days sick in a year.

What is above stated refers chiefly to the condition of farm servants, who are hired by the year, and whose principal employment is about the horses, in the fields, or on the road. There is, however, another class of work-people attached to a farm, who are hired by the day, or by the week, and whose employment is usually in jobbing about the barns, the fences, or the water furrows. These are called labourers, and in their circumstances and mode of living there is a considerable difference between them and the others.

Although their wages are in general at a higher rate than the hired servants, yet they make not such a good appearance in their dress, nor are so well seen to in their victuals, as these. They are generally, as we term it, *from hand to mouth*, always in want; which seems to arise principally from getting their whole wages in money from week to week, which leads them continually to market, providing their daily sustenance; a province left generally to the charge of their wives, who, from this constant running about, get into habits of idleness and want of attention to that good housewifery which is the glory of a decent cottager's wife.

The quantity of coal used by the common labourers is about three fourths of a ton for each person in the family yearly, by farmers about two tons, and in families of the highest rank about six tons. The price at the pit is from five shillings to seven and sixpence the ton, according to its vicinity to Edinburgh.

Such was the state of things in 1795. Now (1830), at the distance of five and thirty years, they are doubtless materially altered. The use of wheaten bread is general; butcher's meat much more common, and cottages more commodious.

14. Political Economy.

Roads so bad previously to 1714, that wheel carriages for the purposes of agriculture were very little used; even till 1760 hay and straw carried to Edinburgh on horseback, and the dung taken back the same way in bags. Sledges a good deal employed in those times: they are mentioned in the turnpike act of 1751, but unnoticed in that of 1755, which shows they had been disused; a proof of the extraordinary progress of improvement when once commenced, in consequence of a demand or desire for it. Forced improvement goes on very differently. The roads of this county are now under one of the M'Adam family. Some recent canals and rail-roads have been formed. One of the most important improvements is the Union Canal from Edinburgh to the Forth and Clyde Canal at Falkirk, which has added greatly to the value of property on each side of its line. See *Edinburghshire*, and *Canal*, in *Sup. to Enc. Brit.* and also Robertson's *Rural Recollections*. Glass, ropes, and soap the chief manufactures. Iron works at Craigmund, where nails, spades, files, &c. are extensively fabricated. Several paper mills, flour mills, and various minor manufactories and works for local consumption.

15. Obstacles to Improvement.

Illiberality of landlords, game, thirlage, the dogs of Edinburgh, who greatly harass the sheep, the chief obstacles.

16. Miscellaneous Observations.

The Farmers' Society of Dalkeith, for the prosecution of thieves and encouragement of agriculture, instituted in 1760, still exists, and has done much good. It is composed almost entirely of practical farmers. Small's plough, the winnowing

and threshing machines early noticed and recommended by this society. The farmers in this county have long had in contemplation to get instituted by legal authority a society for the creation and management of a pensionary fund for the widows and orphans of farmers, on principles similar to those which govern the widows' fund of the ministers of the Church of Scotland.

An appendix to the report contains thirteen papers, some of which are curious in an historical point of view; and as showing

7834. EAST LOTHIAN. 190,363 acres of surface, under an exceedingly variable climate, the greater part of excellent soil, and well adapted for cultivation; but the southern district, Lammermuir, hilly and mountainous, with a moory soil, severe climate, and chiefly under native grass and herbage. Some of the most distinguished Scotch agricultural patriots, authors, and mechanics belong to this county, as Cockburn of Ormiston, Thomas sixth Earl of Haddington, Fletcher of Salton, Adam Dickson, Robert Brown of Markle, the projector, and for a long time editor, of the Farmer's Magazine, Somerville, author of the agricultural Report, Meikle, inventor of the threshing machine, and various others. (*Somerville's General View*, 1805.)

1. Property.

Generally in considerable estates; the largest about 15,000*l.* and not many under 100*l.* a year. Tenure generally of the crown (*i. e.* freehold), some hold of subjects superior (copyhold), and some of the corporate towns of Haddington and Dunbar.

2. Buildings and Implements.

It may be sufficient to state that they are such as we have described in the body of this work as of the best description. Farms generally large; medium of the county about 400*l.* a year; highest 1500*l.* to 1800*l.* The first enclosures were made about 1720; farmers were introduced from Holland in 1710; the two-horse plough in 1772; and the first threshing-machine in 1786. Fallowing was introduced from England about the same time as hedges. The sixth Earl of Haddington was the first proprietor, and John Walker, of Beanston, near Dunbar, the first farmer. He took the hint from some English travellers, while they spent a night at his house, and with whom he had a good deal of conversation upon the subject, so much to his satisfaction, that he made an experiment upon six acres the following summer, which he carried through in spite of the animadversions of his neighbours, who were divided in their opinions as to the sanity of his mind, or the stability of his circumstances. The result of the experiment gave them a better opinion of both, and the return was so abundant as to induce him to extend his next year's fallow break to twenty acres; soon after which the practice began to spread, and so early as the year 1724, fallowing upon all the deep strong soils was common throughout the county, and has continued to be so ever since. There can be no doubt that the early excellence of the East Lothian agriculture was in a great measure owing to the introduction of fallowing, which, together with the use of drill crops, have continued to place it at the head of the Scotch counties. Potatoes introduced to field culture about 1760; turnips first by Cockburn, of Ormiston, about 1720; re-introduced and cultivated in the drill manner in 1760. Flax sown from time immemorial, but chiefly on a small scale, and for the home consumption of the country inhabitants. Every cottager has a small quantity, from half a peck to a peck sown, the produce of which furnishes linen for the use of his family.

Lucern tried with the greatest care; but, owing to the climate, it was found to produce less bulk of herbage than red clover.

3. Grass.

Natural meadows and pastures are not admitted into the East Lothian system of husbandry, as they are found only where nature, or certain local circumstances, render them, in some measure, unavoidable, and are never kept voluntarily, or from an idea of profit. Many farmers fallow land to lie for a few years in grass, especially where it has been exhausted by long and imperfect tillage; but fields of this description are not to be ranked as permanent pastures, for the object is to restore them, as soon as possible, to a state capable of bearing corn-crops to advantage.

Clovers introduced by the sixth Earl of Haddington and Cockburn, about 1720 or 1722, but made little progress till 1740; now generally sown with rye-grass. Application, grazing, soiling, and hay, but chiefly soiling.

4. Gardens and Orchards.

Some few market gardens and nurseries; but the climate does not admit of orchards, which are very rare. Every cottage has a garden annexed, sufficient to produce the various common kitchen vegetables for the cottager's family. This class of people are remarkably attentive to the cultivation of their little spots, and derive great advantage from them, at small cost; the labour is entirely performed after their ordinary work is finished.

5. Woods and Plantations.

Scarcely any of the former, and none of the latter, of any extent, excepting in gentlemen's parks. 800 acres on Tynningham demesne planted by the sixth Earl of Haddington, who wrote a treatise on planting, about 1715. Osiers cultivated by the late Mr. Sherrief, of Captain Head, for which, in 1803, he received the gold medal of the Society of Arts.

6. Wastes and Commons.

Are in this as in other Scotch counties generally enclosed, which is here an easy matter in comparison to what it is in England, in consequence of a general Act of Enclosure by the Scottish Parliament, in 1695.

7. Improvements.

Paring and burning little known, and not wanted, because very little ground is kept long in pasture that can be profitably employed in tillage, and new grass lands do not require these operations.

One attempt at irrigation on a sandy waste near Dunbar, the levels of which were taken by, and the water turned on under the direction of, the compiler of this work, in 1805.

8. Live Stock.

The practice of East Lothian, in this department, does not present much that can be generally interesting. Grazing, in nine cases out of ten, is carried on only as subservient to tillage, and therefore held a secondary object by cultivators. Many cattle are fed, but very few reared, in the county. Almost

how soon, in a rapidly improving age, a man's best ideas and remarks are distanced by those of a few years afterwards. One of these papers describes the origin and progress of the British Wool Society, which was begun in this county by Sir John Sinclair, in 1791. The economy of Johnston's dairy is deserving of notice for accuracy in the details, and for new practices, such as making butter from whey, feeding cows on whins, &c. Macknight, another amateur, and Hepburn, an ingenious landlord and cultivator, are also worth reading.

every person who practises the sheep husbandry, in the lower districts, buys and sells within the year. Some recent attempts have been made to keep flocks of full bred sheep, and, there is reason to believe, with considerable success; but, taking the county generally, such attempts are of little importance.

Cattle. Every farmer keeps a small number of milch cows, but few keep more than are sufficient to furnish a regular supply through the whole year, of milk, butter, and cheese, for their own families. The same attention accordingly is not paid to the kinds of cattle, as in other districts, where they form a more important object of farm management.

A very considerable number of black cattle are purchased annually at fairs and markets, to be wintered in the fold-yard, or fed on turnips in the house. Cattle kept for the dairy, or fed for the butcher-market, comprehend all that are to be found in the county; none are employed in labour. Every part of farm-labour, in which beasts are employed, is executed by horses.

Sheep. Permanent flocks, and regular sheep management, may be said to be almost confined to the higher parts of the county. In the low country they are kept chiefly to eat the turnips, and sometimes sown grass, which is permitted to lie a year or two for pasture. Flying flocks are therefore generally kept; and as soon as they are fattened for the market, which is usually within the year, they are sold off. A considerable number of lambs likewise are reared, only so far, however, as to render them fit for the butcher.

As the great object in the lower districts is feeding, little attention is paid to particular kinds; every farmer keeps those which he thinks are likely to pay best for the food which they consume. The black-faced, or Tweed-dale breed, are most generally preferred for feeding on turnips, because they are most esteemed in the market; but many of the Cheviot breed are likewise kept, and even some of the improved Leicester.

The kind of sheep bred, and most generally kept, in Lammermuir, is the black-faced, or more properly what is called the brooked-faced, a sort of dirty-looking mixture of black and white; they are for the most part horned: when they are fed the widders weigh from ten to twelve pounds per quarter, and the ewes from eight to ten on an average.

The Bakewell breed has been tried, but not extensively till lately. Leicesters are now much more common in East Lothian than they were twenty years ago.

The Cheviot sheep were introduced several years ago, and are kept with advantage in many places. It is not the general opinion, however, that they can ever universally supplant the native breed, or even become equally numerous, with profit.

Of horses very few are bred in the county, not one perhaps in a dozen that are kept. In a district so well calculated for raising corn, it is more profitable to purchase horses, ready for work, than to be at the trouble and expense of rearing them. The farmers here are supplied with this part of stock chiefly from the dealers of Ayrshire and Lanarkshire, who collect many of them in these counties, and procure not a few from Ireland. The horses generally kept are of that moderate size, which may be considered as equal perhaps to any others for combining strength with activity. They may be stated, generally, to be about fifteen or sixteen hands high, and strong built. Many teams are well matched, very handsome, capable of great exertion, and kept in excellent condition.

One will hardly be at a loss to determine the character of a farmer, from the condition of his horses. Very fine high bred horses, exhibiting an appearance of being prepared for the market, may rather suggest the idea of idleness than of labour; but, on the other hand, lean spiritless creatures, worn out by toil and hunger, are the certain indicatives of a bad farmer, of one who is not thriving, and does not deserve to thrive. The man who uses bad instruments cannot have his work well done; and one important and primary step towards good farming, is to keep the labouring stock in good condition. Horses regularly fed and regularly wrought will perform a great deal of labour without falling off either in strength or appearance; it is of great importance, therefore, to distribute the labour as equally as possible, through the various seasons of the year; and if, as must sometimes be the case, an extraordinary exertion ought to be made, they are in a proper condition for making it. When horses do fall off, it requires much more to restore them, than might have kept them in a good state.

Hogs are kept in considerable numbers, in this county, at distilleries, starch work, mills, and breweries. Every farmer keeps a few, chiefly for supplying his own table, and the generality are able to sell some annually. Farm servants too, who have houses, are generally allowed to keep a pig for each family, which adds greatly to their comfort.

Poultry, pigeons, and bees, kept to a moderate extent for home use. Much land on the coast, which would be thought by many unfit for any thing but rabbit warrens, now bears turnips and rye.

9. Rural Economy.

There are not, perhaps, in the island more active or correct labourers than the farm servants here, and certainly none more sober and respectable; and this may, in a great measure, be ascribed to the terms on which they serve. Those servants, who lodge in the houses of their masters, are, generally speaking, on the same footing here as in other places; there is no

thing, with respect to them, which merits particular notice. A small proportion of farm servants, however, belong to this class; married servants are uniformly preferred; those who reside in their master's house are, in many cases, not employed in regular labour, but perform that sort of extra work, and kind of household drudgery, which requires some hands on every considerable farm.

The far greater part of the regular labour is performed by married servants, called hinds; a class more numerous here than in other districts. These dwell in houses provided by their masters, and receive their wages wholly or chiefly in kind; the circumstances are so comfortable under which they are generally placed, as to secure a full supply of such servants at all times. They are more steady generally than young men; their families, and the property which they have acquired, give them a sort of interest in their situations, and afford some security for their continuing longer in their places.

The hind occupies a house provided by his master, for which his wife works in harvest; he has a cow kept all the year round, generally ten bolls of oats, three bolls of barley, two bolls of peas, all of the best quality upon the farm, seed-corn excepted. He has likewise a peck of flax-seed sown, and about the sixteenth part of an acre of ground, well prepared, and sufficiently dunged for planting potatoes; his fuel is carried; he has his victuals during harvest, which is always four weeks, sometimes six; and when he carries corn to market, he has an allowance, provincially called mags. Those who are employed in sowing and building the corn-ricks have, besides the ordinary wages, a pair of shoes and half a boll of wheat. On all well-managed farms, the labour is carried on regularly at set hours: and though it is not understood that servants, who work horses, are absolutely exempt from extra work, yet they are very seldom required to do any thing of this nature.

It is evident, that the value of hinds' wages, in money, cannot be accurately stated; that must vary according to the market price of the articles in which he is paid. On an average of some years past, it could not be less than 25*l.* sterling per annum: now from 30*l.* to 35*l.*

The circumstance which deserves particular attention with regard to this class, and which renders their condition so much more comfortable than that of the labourers in many other places, is the receiving payment of their wages in the necessaries of life. They are far more comfortable than those who receive the same rate of wages in money, any where; they are generally more faithful to their employers, and infinitely more attentive to the interests of their families. They have all the necessary articles of food continually at hand, and seldom need to purchase any thing considerable, except shoes. Their wives makelinen from their own flax sufficient for their families, and often cloth, for other articles of dress. The quantity of corn which they can afford to sell, with the surplus produce of their cows and hens, brings them as much money as fully answers every demand, and enables them to give a better education to their children than is sometimes obtained by persons, considerably above their condition, in some other parts of the island. There are few of this class in East Lothian who cannot read, most of them can write; none of them fail to have their children instructed in these necessary branches of education, including the rules of arithmetic. One sees, about every farm-house, a number of children, vigorous and healthy,

decently clothed, and exhibiting every appearance of being well fed. Not an instance occurs of any of these people soliciting relief from the public, unless they are by some accident disabled from future labour, or overtaken by the infirmities of age. Indeed the times which are hardest for the lower classes, in general, are usually favourable for them; because the corn and other articles which they have to sell bear a better price, while what they have to purchase is not so much affected.

The cottage system, which found many advocates some time ago, was inferior in every view of the matter to the manner in which labourers in agriculture are accommodated here. Many of those who laboured to introduce the new cottage system, deserved all praise for the purity of their motives: every friend of humanity will honour them for the generous interest which they felt in behalf of the labouring poor; but if they had understood the condition of the hinds in this county, they would have found out a much better plan for accomplishing their object, than giving to every cottager land to produce his subsistence. A hind here receives as much corn as such a cottager might be expected to raise; his labour is not interrupted to his employer, nor himself worn out by extra and excessive labour; he has no care upon his mind, no rent to pay, no bad seasons to dread; for whatever may be his master's crop, he is sure of his full share. If the labourer profit by this system, the employer and the public profit still more: the employer does not pay a man who wastes half his strength at other work, nor rely on a servant who may sometimes disappoint him, by attending to other concerns. The public must gain in the increased quantity of human food produced; for, without doubt, an acre of land occupied by a cottager will not yield as much, at as little expense, as if it made part of a farm cultivated by a person with sufficient capital.

Were all the farm servants over the kingdom paid in kind, it may be safely affirmed, from the experience of the places where this practice prevails, that the advantage would be great to themselves and to the public. The master might probably, in some case, find it more convenient to give money, but he is far more than recompensed for any trifling disadvantage attending the other mode, by the valuable moral habits which it is calculated to preserve. Every master, who properly understands his interest, will admit, that he had better pay sober, honest, and industrious servants, than have those of a different description almost for nothing. From their being accustomed to have little money pass through their hands, many of the farmers' servants in this county acquire such habits of saving, that they lay up a few pounds for old age, or to meet any contingency which may require more than their ordinary income.

10. Political Economy.

The first turnpike bill for Scotland was obtained for this county in 1750. The main roads are on the whole good; but the bye-roads still admit of much improvement. The commerce is chiefly in grain from North Berwick and Dumbar. There are oyster and other fisheries on the coast; and starch-works, distilleries, and breweries, but no manufactures deserving notice. The agricultural society of Edinburgh, the earliest in the United Kingdom, was founded chiefly by gentlemen of this county, and especially Cockburn of Ormiston. There are now two county societies; one, that meets at Haddington, and another at Salton. They give prizes annually for the best cattle, &c. and seem to be in a flourishing condition.

7835. BERWICKSHIRE. 285,440 acres (*Edin. Gaz. abridged*, 1829.), chiefly of gently varied surface, but partly of hilly and mountainous pasture. The soil, in the cultivatable part of the county, is chiefly clay; the mountainous part, which occupies fully one third of it, is a continuation of the Lammermuir hills. Climate of the higher parts comparatively dry, but cold and late; of the lower parts, which stretch down to the Tweed, comparatively warm and early. There are no metals or coal in the county; very little lime, but some stone quarries of the trap, and other coarse stones. Every one knows that this county is one of the best cultivated and most systematically managed in the island, and that its products are nearly equally stock and corn. It is the county of Lord Kaimes, one of the greatest patriots and best agricultural authors, and the first to propose a board of agriculture. It is also that of Small, well known as the improver of the plough. (*Kerr's Berwickshire*, 1808.)

1. Property.

No very large estates; largest from 8000*l.* to 10,000*l.* a year. Many of the owners reside on their estates; some farmers have of late years become respectable proprietors. Resident proprietors usually draw their own rents; and those who live at a distance employ an agent, or, if only temporarily absent, have it sent in a bank bill. Proprietors and tenants live in harmony and mutual good will, the rents of the former progressively advancing with the improvements of the country, and the fortunes of the latter augmenting continually, by industrious and judicious attention to improved agricultural practices, and to the amelioration of live stock.

2. Buildings.

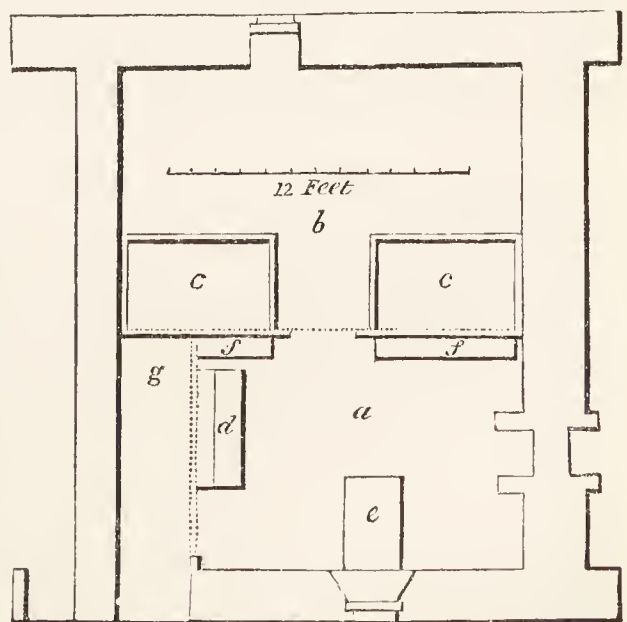
Farm-houses formerly of rough stone, clay, and thatch, now greatly superior to the houses that were occupied by the middling gentry, forty or fifty years ago. An excellent plan of a farmery given; but the cottages of the hinds appear uncomfortably small, and are calculated for close-paneled beds, which, wherever health and cleanliness are objects, ought to be discarded. These cottages contain only one apartment, and a sort of dark lumber place, formed by the position of the paneled beds. We much wonder that the reporter, who talks so much of the commodiousness of the houses of farmers, should not have displayed a little more feeling on the subject of the accommodations of cottagers. These remarks apply more particularly to three plans of cottages, given in Kerr's Report, Dec. 14, 1830, in the general plan of a farmery. (*Pl. facing p. 97.*) A detached plan of a cottage (*fig. 1125.*) is given, rather better arranged than these double ones, but still, in our opinion, highly objectionable. It has two windows, whereas the others have only one each. The larger window is in the kitchen (*a*), the smaller in the back place (*b*); these are separated by two beds (*c*); in the kitchen are shown a plate-rack and dresser (*d*), table (*e*), and two chests (*f*). In the lobby a place for coals (*g*). No water-closets in any of the plans.

3. Occupation.

Farms generally large, and held on lease for different periods, from ten to thirty years, but commonly for nineteen years. Mode of culture aration and pasturage alternately. "Under this system of alternation, judiciously conducted, it may confidently be asserted that a farm of 1000 acres will raise as

much grain as one of equal size entirely under perpetual tillage, and will produce in addition as much beef, and mutton, and wool, as a separate farm of 200 or 300 acres under

1125



permanent grass. If this estimation be well founded, of which the reporter has no doubt, this alternate system is obviously of superior profit to the tenancy in the first place, to the landed interest secondarily, by increased rents, and to the public ultimately and always, in the proportion of at least

twenty-five per cent beyond what can be produced from the two branches separately pursued on the same extent of equal land.

In the hill district, the lands are mostly occupied as breeding sheep farms; taking advantage of all the favourable pieces of land, susceptible of cultivation, for raising a little grain to supply the farmer's family, servants, and horses; to afford little and fodder from the straw during winter, by which dung is produced; to apply that dung to raise turnips, to carry on their sheep stock during winter, and, finally, to produce crops of artificial or sown grasses, for hay and early pastures, and to the great amelioration of permanent grass lands.

In the neighbourhood of towns and villages, various small possessions, from two or three acres or less, to twenty or more, are let on leases of various endurance, but mostly for short periods to villagers who keep one or two horses, which they chiefly occupy in kindling materials for road makers, coals to the other villagers, lime, or any such employment as may occur. The great mass of the land throughout the county is let in farms of every variety of size, from 40 to 50 acres, up to 1000 or more, to tenants on leases of fixed endurance, mostly for nineteen years.

The character of farmers in a large district of country must be various; but those of Berwickshire are very generally most respectable and intelligent, and their success has been deservedly proportional. They have almost universally risen completely above the operative class in knowledge, education, and manners, assimilating in every respect to the character of country gentlemen. In every corner of the county they are to be seen carrying on extensive and costly improvements, by draining, enclosing, liming, and marling; and by careful and judicious improvements of their live stock, sheep, cattle, and even horses, with all the eagerness and intelligence of commercial speculators. They trust to the certain profits of future years to reimburse their large expenditures with reasonable profit, which they are enabled to do through the sufficiency of their capitals, and the security of their leases. The former is derived from their own successful and intelligent industry, or that of their fathers; the latter from the good sense of the landlords, in seeing their own interests most materially interwoven in the security and success of their tenants.

4. Implements.

No waggons or wheel ploughs, and, though drilling turnips is universal, only one or two sorts of drills in use. Few implements, and those of a simple construction, suffice for the best practitioners in every art.

5. Enclosing.

The cultivatable lands are universally enclosed, and subdivided into regular fields, generally by hedges; but sometimes by stone walls. In the mountain district, the farms are neither enclosed nor subdivided. The boundaries of each farm are indicated by landmarks, and round each farmery there are generally two or three small fields for convenience or cultivation. Trees very generally planted in hedge-rows; hedges always cut with a bill in the wedge shape; never clipped and rounded, or broader at top than bottom; the sure means of hindering the production of side shoots, and in time producing naked places and gaps in that part of the hedge.

6. Arable Land.

Ample details of the turnip culture in drills is given.

7. Orchards. Woods.

None of the former worth notice. Some native copses and woods, and artificial plantations, but not much woodiness, excepting round gentlemen's seats.

8. Improvements.

In this county were begun about 1750, when Swinton of Swinton drained, marled, and completely enclosed his whole

estate. Nearly about the same time, Hume of Eccles effected similar improvements. Both of these gentlemen were actuated by the example and acquaintance of Cockburn, of Ormiston. Henry Home, Lord Kaimes, was one of the early improvers of this county about 1746, at Kaimes, now Besborough. About 1750, the ardour of enclosing and improving the land spread generally among the Berwickshire proprietors.

Paring and burning, irrigation and embanking, not practised or required.

9. Live Stock.

The cattle of Berwickshire are so much mixed by crossing, as scarcely to admit of any particular description. Upon the whole, they are short horned, thin hided, and kindly feeders, and have been much improved by crosses with bulls of the Teeswater breed, which is the kind chiefly admired in this district. Generally speaking the oxen are not carried on to any age, and they are never worked. They are well fed from their youth up, and are generally fed off for market in their fourth year, very few reaching five years old. Cows, on the contrary, are generally old before they are fed off. Great numbers of smaller cattle are bred upon the lower hills, and are disposed of to graziers in the low country for feeding, either on grass or turnips, or by a succession of both; and many Highland cattle of various descriptions are bought in yearly for consuming straw, or for feeding on turnips during winter, and on grass in spring and summer.

The sheep bred in Berwickshire are of several kinds. In the most exposed of the Lammermuir and Lauderdale hills, the flocks are mostly of the black faced, or Tweeddale kind, and are there exclusively kept for breeding. In the cultivated tract the new Leicester breed, in a great variety of degrees of perfection, now universally prevails; and it is believed that no other known breed, in the peculiar circumstances of this county, could be so profitable to the farmer. They require, however, always to have abundance of food, and easily procured; for, being short-legged, heavy-bodied, and carrying a great weight of wool, they are unable to undergo much fatigue or hardship, and do not thrive unless plentifully supplied at all seasons. This supply the agricultural system of the district amply affords, and is indeed admirably calculated for providing. On some of the best interior hills, and upon the higher exterior lands, verging on Lammermuir and Lauderdale, called the moor-edges, the Cheviot breed, or long sheep, are kept. An intermediate breed between the Cheviot and Leicester, usually called half-bred sheep, is very prevalent upon the best of these situations. As a singular circumstance, the reporter records the case of a ewe of this county, which produced eleven lambs in three succeeding seasons.

Horses, as in East Lothian, brought from the west of Scotland.

10. Rural Economy.

Farm servants managed as in East Lothian, and, indeed, almost every where in the low country of Scotland.

11. Political Economy.

Commerce chiefly grain, wool, and salmon; scarcely any manufactures, excepting the paper-mills. The salmon fishery, including Berwick bounds and the English side of the river, employs about seventy small boats, and nearly 500 fishermen. All their fish are sold to a very respectable fraternity of traders in Berwick, named coopers, from their former business of making kits, and boiling the fish, which is now entirely discontinued. By them the salmon are packed in ice, and sent to London, to be disposed of by factors on commission. This employment of ice was first essayed by Messrs. Richardson, of Perth, on the suggestion of George Dempster, of Dunnichen, Esq. who had accidentally read that such a practice was not unusual in China.

7836. ROXBURGHSHIRE or TEVIOTDALE contains 448,000 acres, of which about three fifths are in sheep pasture, and the remaining two fifths, are occasionally under the plough, except about 8000 acres occupied in woods, pleasure-grounds, and the sites of towns and villages. The surface is exceedingly irregular, being in some places ninety, and in others 2000 feet above the level of the sea. The climate is equally various, and excessive rains, winds, frosts, and even hail and snow are by no means uncommon in spring and harvest. There is a good deal of moss and peat soil in detached portions over the county; but the general character of the district is, that the low or arable part consists chiefly of a light or turnip soil, and the hilly division of dry green pastures. There is a good deal of high, wet, barren land; but this is by no means the character of the county at large. Limestone abounds in most parts of the district, and coal has been found, but is not worked. The agriculture of the arable lands is in all respects the same as that of Berwickshire, and that of the pastures resembles the store farming of the latter county and East Lothian. Dawson, of Frogden, belongs to this county, and may be looked on as one of the greatest improvers of British agriculture. (*Douglas's Roxburghshire, 1794. Edin. Gaz. abridged, 1829.*)

1. Property.

Generally in large estates, and little change of proprietorship has taken place for many years. The largest between 25,000l. and 55,000l. a year.

2. Implements. Arable Land.

Fanners, the reporter states, were first made in this county by one Rogers, a farmer, of a mechanical turn, near Hawick, in 1733, or at least before 1737, who is said either to have seen a model, or a description of one, which had been brought from Holland. (*Report of North. m.*) Robertson states (*Rural Recollections*, p. 147.) that he himself conversed with an old farmer, the late Mr. Thomas Shiells, at Grothill near Edinburgh, who with his own hands made the first winnowing machine in the Lothians, from a model of one imported from Holland.

Arable land enclosed, partly by hedges and partly by walls of loose stones, without mortar.

Ploughing with two horses, without a driver, was practised in this county before it was in any other. It was taught by Dawson, of Frogden, who introduced the drill culture, to James Macdougall, farmer, at Linton, in Tweeddale, alive at the time of making up Douglas's report: it spread rapidly afterwards through the county, and the neighbouring ones of Northumberland, Berwickshire, East Lothian, and Tweeddale. Potatoes first planted in large beds about 1754; in 1768, in drills in the fields. Tobacco, during the American war, was cultivated to a considerable extent in the neighbourhood of Kelso and Jedburgh, and in some other spots. Its produce was so great, that thirteen acres at Crailing fetched 104l. at the low rate of fourpence per pound and would have brought more than three

times as much, had not an Act of Parliament obliged the cultivator to dispose of it to Government at that price. This county lost about 1500l. sterling by that Act, which passed while the tobacco was growing; yet it excited not so much murmuring and clamour among the sufferers as have been elsewhere repeatedly raised, with less reason, against other Acts in no respect so arbitrary and oppressive.

3. Gardens and Orchards.

Thrive better in the lower parts of this county than in those on the east coast. At Melrose, Jedburgh, and Kelso, are the remains of orchards planted by the priests several centuries ago, the pear-trees of which are very productive. Wonderful stories are told of their fertility. A single tree of the Thorne pear at Melrose has for these fifty years past yielded the interest of the money paid for the garden where it stands, and for a house let for seven pounds sterling yearly. Another tree there has carried fruit to the amount of three pounds annually, at an average for the same period. In the year 1795, two trees there brought to perfection about 60,000 pears, which were sold for eight guineas. These facts are well authenticated. There are also several more recent orchards near the same places, and 120 acres of nurseries. Of these one of the oldest and largest in Scotland is that of Messrs. Dicksons, of Hawick.

4. Woods and Plantations.

To the extent of 5290 acres; nearly two thirds artificial.

5. Live Stock.

Cattle, a mixed breed, as in Berwickshire. Sheep of the Cheviot kind said to be greatly improved by a cross with the

Dishley breed, introduced about 1765, by Robson, a pupil of Cully; but this is stoutly denied by most of the Cheviot breeders. Merinos and other sorts have been tried, but sufficient time has not elapsed to ascertain the result.

6. *Rural and Political Economy.*

Farm servants on the same plan as in East Lothian. Roads improving; no canals; little commerce, and almost no manufactures.

7837. SELKIRKSHIRE. 172,160 acres, almost wholly of mountainous surface, the lowest part 300 feet above the level of the sea; many houses are 600 and some more than 1000 feet above its level. The highest mountain is 2370 feet. These mountains are generally of granite or whinstone, and the surface soil is commonly gravelly and dry. In the valleys are clay, peat, morass, and lakes. The climate is cold and rather moist. There are no metals, nor coal, lime, or freestone. The most remarkable thing attending this county is, that its hills and mountains are almost every where clothed to their summits with sound sheep pasture, of which there are estimated to be 148,000 acres; 8800 acres in aration, 2000 in wood, and the rest in gardens, houses, roads, lakes, &c. (*Douglas's General View*, 1796. *Edin. Gaz. abridged*, 1829.)

Property in few hands, and in large estates. The farms are large, and the leases generally shorter than on arable farms. The sheep are a variety of the Cheviot produced by repeated crosses with the native mountain black-faced breed. In all respects the husbandry of this county may be considered the same as that of the mountainous districts of the preceding

counties. There is a woollen cloth manufactory, and an excellent porter brewery, by a pupil of Meux, at Galashiels. Some agricultural societies were attempted in this and the adjoining counties about 1793, but they were of very short duration.

7838. PEEBLESHIRE or TWEEDDALE. 229,778 acres, mostly of mountain, moor, and bog, but with about one tenth part arable. The lowest part of the county is 400 feet above sea-level, and grain is cultivated to the height of 1000 feet. The climate is late, cold, and moist, and the soil moory, clayey, or sandy, according as the water is pent up; the rocks of the mountains are freestone, granite, trap, or claystone. The only minerals worth notice are lime, whinstone, and freestone. The general appearance of the country is wild, and rather dull and dreary, than romantic or sublime. The agricultural survey of this county is by the Rev. Charles Findlater, and it abounds with more valuable matter on political agriculture, on leases, prices, restrictions, markets, &c., than any survey that has been published, without a single exception. In fact, it was found to take such a masterly view of the moral incitements to agricultural industry; to expose the system of tithes, entails, lawyer's leases, &c., that it was rejected by the Board, as likely to offend the English clergy and higher classes, and the author was reduced to publish it himself. It has certainly, through the medium of the extracts from it published in the *Farmer's Magazine*, been the means of enlightening thousands, both of farmers and landlords. The fundamental principle which Findlater lays down and illustrates under the heads of leases, size of farms, usury, capital, dearth, monopoly, forestalling, government interference, tithes, poor, and other topics, is, "That the best mode of ensuring the invention and prosecution of the most advantageous measures is, an arrangement which shall communicate to those on whom their execution is devolved a sufficient personal interest in their invention and execution." To some he doubts not such views will be considered as foreign to the report of a county; whilst to others they will constitute its most essential value.

The state of property and husbandry of the country may be considered as the same as that of the other mountainous districts. The black-faced sheep are in almost universal use, except in milder situations, where the Cheviot has been introduced. There is no commerce but by retail, and only some very trifling woollen manufactures in the county.

In the Appendix an account is given of the improvement of the Whim, a flow-moss of 100 acres, twenty feet deep, and at an elevation of 700 feet above the level of the sea. It was begun to be drained in 1731, and in ten years a mansion was built, and surrounded by woods and pleasure-grounds, which show, as the Duke of Buccleugh, the proprietor, intended, the wonderful influence of art over nature. "The plantations (originally extensive) have been improved and enlarged since the property came into possession of the Lord Chief Baron; and he has also greatly enlarged the house, adding a court of offices upon a large scale, and ornamented in front, extending also the lawn. The place has, upon the whole, an air of magnificence. In the pleasure-grounds there are several artificial pieces of water. East of the house (where the soil is dry and covered with sweet grasses) the surface is agreeably diversified by gentle swells, tufted with trees. A wild wilderness walk, through a small wood, lands you upon the banks of an artificial lake, with islands, covering an extent of six or seven acres of surface. What chiefly strikes the visitor at Whim is the strongly marked contrast betwixt the improvements of human art, and nature in her wildest form, here found in immediate contact. Your ears are at once saluted with the warblings of the blackbird and thrush from the plantations, and the wild notes of the plover, the curlew, the grouse, and other moss birds from the flow-moss." (*Findlater's Report*, &c. 1804.)

7839. DUMFRIESSHIRE. 644,385 acres of maritime, vale, and mountain lands, in the proportion of one, four, and seven. The climate is variable, comparatively mild, but moist. The soil of the maritime district is light, and generally on sand, gravel, or rock; that of the vale or midland district is gravelly, sandy, or moory. The mountains are of schist, whinstone, or red freestone, and thinly covered with corresponding soils or moss. In some places they are covered with dry pasture, but more frequently with a mixture of grass and heath. The principal metallic ore found in the county is lead; but several others, as iron, copper, antimony, &c. exist, and the latter has been worked. Coal has been found, but not in strata sufficiently thick to be workable. Marble also and slate have been worked, and lime, freestone, and whinstone in abundance. There are several mineral springs in the mountain district, the principal of which is the spaw at Moffat. Fish, and especially salmon, are caught in moderate quantities in the Nith and Annan. The celebrated improver Craik was a proprietor in this county, at Ardbigland, near Dumfries, now the property of his son. (*The Rev. Dr. Singer's General View*, 1812.)

1. *Minerals.*

The lead mines occupy very barren grounds, remarkably bleak and elevated; but they are a great fund of industry and riches, and they furnish a part of the county with an excellent market for the surplus grain produced in that part. Lead hills, with the mines, are in the county of Lanark, and belong to the Earl of Hopetown, who draws about 7000*l.* a year from these mines. Wanlockhead mine is in Dumfriesshire, belonged to the Duke of Queensbury, and returns to the proprietor near 5000*l.* a year.

2. *Property.*

In large estates, owned by 453 persons. The Duke of Buccleugh's estate of very great extent. Some estates are managed by their owners, and others by commissioners having power to let. In large properties it is common to entrust the collecting rents, and arrangements relative to leases, buildings, fences, and courses of crops, to factors residing on or near the lands, who represent their constituents (if not personally present) in county and parish meetings. Millar of Dalswinton has gone over an estate of 5000 acres in twenty-five years, and improved the whole of it, with the exception of a portion which, in 1812, was under process and promised to be soon completed. His plan was not to farm his lands himself, but to prepare them, by improvement, for being let to farmers.

3. *Buildings.*

While the reporter expatiates on the ample accommodations of the modern farm-houses in this and other counties, he gives the following information as to cottages, which, we regret to find, seem by no means improved, either in this or in other

parts of Scotland, in the same ratio as the habitations of inferior animals. "A common, and not inconvenient, cottage is put up as follows, viz.: stone and lime walls, seven feet high, thirty-six feet long, and fourteen to sixteen feet wide within, the roof of Scots fir, which is preserved from the worm by smoke, and covered with thatch; a chimney at one end, and an open passage for smoke to the other; affording two apartments below, one of them a kitchen, and a central apartment opposite to the door; the one end boarded over, and the other open. Such a cottage may be erected for about 50*l.* or 40*l.*; and, with half a rood for a garden, it would let at 3*l.* a year, or more, according to its finishing." Doubtless the reverend gentleman made but short prayers when he visited the sick in such smoky cottages: the surgeon need not dismount from his horse; he may speak to his patient through the window, and feel his pulse with the butt end of his whip.

4. *Occupation.*

Sheep farms from 300 to 3000 acres; arable farms from 50 to 600 acres. Leases universal, and generally for nineteen or twenty-one years. Wilkie's variation of Small's plough is in general use, as clearing the mould-board better in soft soils. The Berwickshire system of culture is practised on the turnip soils; the East Lothian on such as are loamy or clayey; and the store system on the mountain district. The cattle are of the Galloway breed, and sheep, Cheviots, or the black-faced mountain kind. More poultry is kept than in most other counties, in order to consume the light grain. Many of the fowls and eggs go to Edinburgh; but the greater part of the produce and sales in eggs go in small oval baskets, packed in

carts, to Berwick, for the London market. In one or two instances the *Holcus lanatus* has been cultivated on reclaimed bogs with success, but is intended to be succeeded by better grasses as soon as they will bear them. The drill culture of turnips was introduced by Craik about 1745. Draining has been extensively practised, irrigation in a few places, and some embankments made on the Solway Firth, and the Nith and Annan. There are few orchards. Some remains of coppice and forest, which, according to appearances and authentic records, seem in former times to have spread over great part of the county; and numerous young plantations. Some years ago many young Scotch firs died from the attacks of the *Teredo pinorum*, as some suppose; but the cause does not seem clearly known. Some very large oaks, beeches, elms, ashes, and larch firs are described in the Report.

5. Improvements.

As a specimen, we shall give some notices of what has been done on the estate of Mount Annan, by General Dirom. The extent of Mount Annan estate is 2750 acres. The general began his improvements in 1793, and planted, before 1819, 168 acres. Assisted in laying out a considerable extent of public road and building bridges, the road passing through the estate. Made an improvement in the construction of lime-kilns, since perfected by Booker of Dublin. (3863.) The lime quarried and dried by means of a small stream from more elevated lands; this stream being made to turn an overshot wheel, which works two pumps. The village of Bridekirk began in 1800 (3850.) on the new road, and where the river Annan affords ample falls for machinery. Farms arranged of different sizes, and three eminent farmers settled with a view to improvement. Cottage farms, one or two; cottages; improved stock on the demesne farm; improved farm buildings; leases for fifteen years; stone quarries opened, others drained and improved; brick clay found, and bricks made; salmon fishery improved. Irrigation, florin, spring wheat, moss composts, mole plough, and steaming apparatus introduced. A cross moss-cutting machine, invented by the overseer, William Holliday, for cutting the furrows across in improving moor, instead of cross-ploughing; the latter operation being not only very laborious, but one which seldom succeeds in cutting the furrows into pieces small enough to be afterwards easily harrowed. This machine consists of two circular knives, if they may be so called, six inches deep in the blade, with a blunt edge fixed upon and embracing

7849. KIRCUDBRIGHTSHIRE, 561,641 acres, and WIGTONSHIRE 288,960 acres (*Ed. Gaz. abr.* 1829), possessing great similarity of agricultural character, have been included in one report, as the district of Galloway. The climate moist but rather warm; in some parts of Wigtonshire, in genial seasons, figs ripen on the open garden walls. The soil and surface of Galloway is exceedingly various. Almost the whole of Wigtonshire is very little elevated above the surface of the sea, but great part of Kircudbrightshire is hilly and mountainous. The better soils are for the most part light, and of this and hazel loam there is a considerable portion in Wigtonshire. In some places in Kircudbrightshire it is clayey or alluvial; and there is a great deal of peat-moss, and bog, as well as improved, or grass-bearing peat. The rocks of the county are argillaceous, granite, or whinstone with some freestone. Some mineral veins have been found; and one of lead, near Gate House of Fleet, was worked at the expense of the compiler of this work for some time, but without success. In an agricultural point of view, Galloway is chiefly remarkable for its breed of cattle. Gladstone, a millwright, who has invented a reaping machine, and proposed some improvements on the threshing machine, and other implements, is of this district. (*Smith's General View*, 1810.)

1. Property.

More divided than in most of the counties of Scotland. Largest estate, 50,000*l.* a year, Earl of Galloway's, in Wigtonshire. Estates in general well managed: landlords in general advance money at five, six, or seven and a half per cent, for buildings, fences, drains, mineral manures, roads, &c. Dunhar Earl of Selkirk, a disciple of Craik's, one of the first who set the example of improvement, which has been persevered in by the same family to the present time.

2. Occupation.

In the moors, where breeding cattle and sheep is the object, farms sometimes seven or eight miles square, some ten or twelve. Arable farms 500 to 600 acres; 200 acres perhaps the average. Leases nineteen or twenty-one years, to which the late Earl of Galloway superadded the tenant's life. "From this two good effects were supposed to result; 1st. That the landlord was freed from the expenses of buildings and repairs. 2dly. That the tenant presuming (as we always do) on the continuance of life, would be disposed to go on with his improvements to the last. There is certainly, however, much liberality in the idea."

3. Enclosing.

Galloway dykes (5060.) very generally in use; some useful remarks on the necessity of bonding them sufficiently, and working the coping-stones to a flat under-surface.

4. Arable Land.

Till the middle of the eighteenth century, four and sometimes six horses yoked abreast in the old Scotch plough, and tumbrils (carts with low wheels without spokes) and cars in use; now all the improved implements; the husbandry of East Lothian on the alluvial lands and loams, too heavy for turnips; that of Berwickshire on the turnips soils; cattle bred on the mountains and moors; carrots cultivated in some places, and found to answer well; florin tried on bogs; some irrigation; embanking near Wigton and at Kircudbright, and much draining; also paring and burning, and various other means of improving bogs and flow-mosses tried, in conjunction with draining. Corn in the late districts gaited. (3176.) Barley is a good deal cultivated, and thin hot barley cakes, from dough, baked the same morning, and spread first with butter, and then with honey, and folded or rolled up (like the tef of the Abyssinians), form a part of the breakfast bread of all who can afford it in Wigtonshire.

5. Orchards.

Rare. "Some proprietors furnish their tenants with fruit-trees for their gardens, when they are willing to be at the trouble of cultivating them. But, from the scarcity of fruit in the country, and the idea that the plundering of an orchard is a very venial trespass, such as do cultivate them, frequently do not gather the fruits. In this we believe there is nothing peculiar to Galloway. There are a few market gardens and several nurseries."

the whole of the exterior circle of two small broad wheels, and as they go round the knives cut the furrows across. The axle and frame of a roller are used for these wheels, so that the weight may be increased by loading the box of the frame, if it should be necessary to make the knives cut through the furrows. It is dragged with great ease across the ploughed moor by one horse; and when it is moist the furrows are cut through with the greatest facility, in pieces of any length, according to the number of turns taken by the machine. The furrows, when a little dry, are then turned over by the brake (break) harrow, and being all cut into small pieces, are in the best state for being reduced by repeated harrowing, or for being thrown together in heaps and burnt.

6. Weekly Reports.

"In carrying on the improvements which have been mentioned, at a considerable distance from my general residence, they have been greatly facilitated by requiring my overseer, or manager, to send me a weekly report of what was doing upon the farm and the estate. It shows how the servants and horses have been employed during every day; contains a journal of the weather, and of the progress of different works; and a state of his receipts and disbursements during the week. These reports, besides enabling one to judge of what is doing, and to give any directions that may be necessary, are extremely useful to refer to, and excite the overseer and servants to be diligent in my absence."

Increase of population on the estate in fifteen years, 396; viz.: from 175 to 571 inhabitants. Total expense of purchase and improvements up to 1811, 50,000*l.* Clear annual rental at that time, 2000*l.* a year, exclusive of the value of timber, and of the mansion, garden, and hot-house, &c. as a gentleman's residence.

7. Political Economy.

Improving roads, and some canals and railways; some commerce by sea with the port of Dumfries; manufactures considerable; paper, stockings by frames, muslin weavers. A small iron-work at Kirkconnell, in which from three to four dozen spades daily are made. Cotton spinning and weaving in a few places. Carpet weaving, &c. "Salt, from the richest parts of the sea sleech, collected with horse drags in dry weather in summer, and then placed so as to be washed and filtered, and the brine that runs out of it boiled."

6. Woods and Plantations.

Of a very limited extent, but rapidly increasing. John Earl of Stair planted extensively at Mount Kennedy, in the beginning of the eighteenth century; and Douglas Earl of Selkirk soon afterwards. The Earl of Galloway, the present Earl of Selkirk, Murray of Broughton, and various others, are great planters.

7. Live Stock.

The Galloway breed of cattle is well known. The breeders perhaps, in general, understand the management of cattle as well as, or better than, most others in the kingdom. They all know how to distinguish a good bull or a good cow from a bad one: and fail not to select from their own stock such as are best adapted for the improvement of the breed; and from this general attention, it no doubt arises, that the cattle in Galloway are pretty uniformly good. But among them have arisen no enthusiasts in the profession; none who have studied it scientifically, or dedicated their talents almost exclusively to this one object. No fair test has yet been given, of what might be done by a proper selection of the choicest individuals of both sexes for breeders, and uniting them in such a manner, as seemed best calculated to diminish their faults and heighten their properties, by crossing the progeny of these from time to time; and still carefully pursuing proper combinations of the most approved males with the finest females, till the improvement was carried to the greatest perfection of which the breed is susceptible. No Bakewells, no Culleys, no Collings have yet appeared in Galloway; who, with a skill, the result of long study and experience, have united sufficient capital, and by the success of their experiments have made great fortunes, and transmitted their names to the most distant parts of the kingdom. Few of the Galloway cattle (comparatively) are fed for home consumption. Dairying with Ayrshire cows has lately been introduced, and very good Dunlop cheese made.

The sheep for the low districts are of various breeds, those of the highlands the same as in the mountain districts of the counties already described. The South Down is found to answer well in Wigtonshire, and also the Leicester.

Horses. Galloway formerly possessed a breed of horses peculiar to itself, and in high estimation for the saddle; being, though small, exceedingly hardy and active. Accustomed to a rugged and mountainous country, and never employed in the draught, these were sure-footed, and travelled with spirit in very bad roads. They were of a larger size than the ponies of Wales, or the shelties of the north, being from twelve to fourteen hands high. It is reported that this breed originated from Spanish horses, which escaped from a vessel of the Armada, that had been wrecked on the shores of Galloway: but it appears probable from some passages in Shakspeare, that the Galloway horses were in repute at an earlier period. It is much to be regretted that this ancient breed is now almost lost. This has been occasioned chiefly by the desire of farmers to breed horses of greater weight, and better adapted for the

draught; and from the little value attached, in times of tranquility, to horses well calculated for predatory excursions. As the soil and climate of Galloway are peculiarly adapted for rearing horses, there cannot be a doubt that under proper management, they would in general become excellent, and add much to the value of its produce. Hitherto few more have been bred than what were necessary to supply the demands of the district.

Swine increasing since the introduction of potatoes; and the prejudice against eating the flesh common to this and most districts of Scotland gradually declining. Ringing not practised; but the two strong tendons of the snout cut by a slight

incision, about an inch and a half above the nose, when the animal is about two months old.

Bees of this district produce honey equal, if not superior, to any in the world; its excellence supposed to depend on the profusion of wild flowers, especially white clover and heath.

Game abundant; a few ptarmigans in the highest mountains.

8. Political Economy.

Roads greatly improved of late; and some cotton, woollen, paper, and other manufactures introduced.

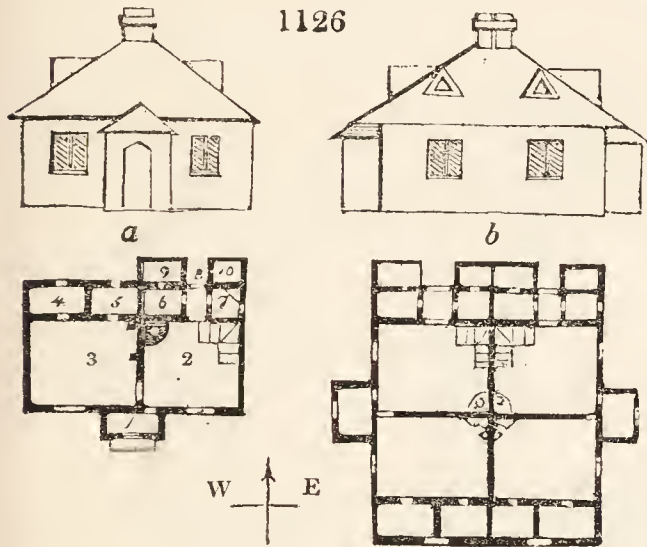
7841. **AYRSHIRE.** 664,960 acres of irregular but not mountainous surface, and clayey or mossy soil, under a moist climate; half the county bog, hilly pasture, or waste, and the rest chiefly under alternate grass and corn. The agriculture followed is in great part the dairy system; Dunlop cheese, already described (7063.), being chiefly produced in this county. (*Aiton's General View*, 1811.)

1. Minerals.

Coal and limestone are to be found in most parts of the county, and there are several kinds of building-stone, but no metallic ores worth working, excepting iron. Coal is the staple mineral, and is exported in large quantities to Glasgow and other towns, along the west coast, northward and southward.

2. Buildings.

Some good castles and mansions, as Culzean, Loudon, Eglington, &c. Farm buildings are improving, though but slowly. Some neat elevations, and comfortable interiors on Lord Eglington's estates; single (*fig.* 1126. *a*), and double (*b*).



Each of such cottages is surrounded by a neat garden, containing a pigsty, pump, and bee-house; and the house containing a porch (1), kitchen, oven, and stair to bed-rooms (2), parlour (3), store closet (4), bed closet (5), pantry (6), coal closet (7), back entrance (8), tool house (9), and water closet (10), with two garret bed-rooms over.

3. Occupation.

Farms small, from 50 to 150 acres, and their culture imperfect and irregular, though rents are high from the population of the manufacturing towns.

4. Live Stock.

Horses are bred and sold under the general name of Lanarkshire or Clydesdale, and are in great demand; as are the Ayrshire cows for the Edinburgh and Glasgow dairymen. Indeed these cows, as we have seen (6789.), are preferred to all others in most parts of the low country of Scotland. The native horses began to be improved by crosses about 1740. In that year Robert Woodburn, in Mains of Loudoun, sold what was then considered the best stallion in the county, at the price of five guineas. The common price of draught horses did

not then average more than 3*l.* each. Till about 1780, the work usually done by farm-horses was not more than one half of what they now perform. Four horses were then yoked to every plough, while as much is now turned over by two horses. (*Aiton's Dairy Husbandry*, p. 180.)

5. Woods and Plantations.

Most of the proprietors are extensive planters. On the Culzean estate are extensive woods, raised in the face of the west winds; most of the trees lean to the east, excepting the common maple, which is generally erect, or nearly so, and is one of the best trees for an exposed sea-coast. There are a few native coppice-woods, and some fine old birch, ash, and oak trees round Eglington Castle.

6. Improvements.

Captain Smith, the proprietor of a small place abounding with peat bogs, about 1790, began to drain and dig, and lime the surface, and succeeded in reducing the peat to a black mould, and rearing tolerable crops of oats, potatoes, and clover. After five or six years, he was able to venture horses and cattle on these bogs; but at first every operation was manual.

7. Political Economy.

Carpet and other woollen manufactures at Kilmarnock; thread at Beith, cotton at Catharine, iron at Muirkirk, salt and kelp on the shores, and earthenware and the usual minor manufactures, as leather, hats, &c., at various places.

The harbour and other works carried on at Ardrrossan, under the auspices of the Earl of Eglington, and the harbour of Troon, and the railway from thence to Kilmarnock, formed almost entirely at the expense of the Duke of Portland, are worthy monuments, no less of the enlightened judgment and energy, than of the wealth of these two patriotic noblemen. The harbour lately completed is one of the safest, most capacious, and most accessible on the west coast of Britain; possessing many advantages over the harbour in the Frith of Clyde, situate in a narrow channel, which can be navigated only when the wind blows from particular points, and which, for upwards of twenty miles below Glasgow, is both shallow and dangerous. A circular pier of 900 yards was finished in 1811, and every thing was then ready to begin the wet-dock, which, according to Telford's plan, was to contain from 70 to 100 vessels, in water sixteen feet deep. The other works have rather languished of late, and are not likely to be completed soon without public aid. It was part of the Earl of Eglington's plan to raise a neat regular-built town at Ardrrossan, in which some progress has been made; and he has constructed excellent baths, which draw to it a number of visitors at the proper season.

The harbour at Ardrrossan was only a part of the general plan, and that from which, viewed by itself, the smallest advantages perhaps were to be expected. The leading idea was to open a direct communication between Glasgow, Paisley, and other large towns in the vicinity and the west coast, instead of the present circuitous passage by the Frith of Clyde. A canal was therefore to be cut from Glasgow to Ardrrossan, about thirty-one miles and half, at the estimated expense of 125,000*l.* Of this a third part was executed, that is, from Glasgow to Johnstone, and this part, it is said, cost about 90,000*l.*

The harbour at Troon, connected, as it now is, with Kilmarnock, by means of an excellent railway, seems to possess almost all the advantages of that of Ardrrossan, and promises to become, in a much shorter period, of vast utility to the populous country around it.

7842. **LANARKSHIRE or CLYDESDALE.** 556,800 acres, in great part mountain, moor, and peat-bog, with a portion of friable loam, and some retentive clays. The climate is cold, moist, and unfavourable, excepting in the low vales, where vegetable is chiefly injured by spring and autumn frosts. Average of the rain which falls at Glasgow, 30.8 inches. The minerals are lead, ironstone, coal, limestone, freestone, and whinstone, all worked to a considerable extent. The lead mines at Leadhills have been already noticed under Dumfriesshire. The husbandry of the county is chiefly distinguished for its breed of horses, and for orchards, the latter a rare production in Scotland. John Naismith, the author of a work on Industry, another on the Elements of Agriculture, and also of the Report, seems to have been a native of this county. (*Naismith's General View*, 1803.)

1. Property.

Three fourths of the surface the property of great landholders; the rest much divided. Farm-houses and offices were formerly very indifferent; but in this as in other adjoining counties, where the leases of farms fall in, the landlord generally enlarges or renews the buildings, as a necessary step to getting the full rental value for the land. A good deal of ground fenced out to operative mechanics, weavers, &c. for building cottages.

2. Occupation.

Much the same as in Galloway. Breeding farms are large, and corn farms moderate. The mountainous district is occupied mostly with flocks of sheep: upon the ridges on the E. and W. sides, where the ground is marshy, and less proper for sheep, and the exposure too bleak to encourage the cultivation of corn, cattle are mostly pastured, and those generally milk cows and their young, many of which are reared; a small quantity of corn only being cultivated, principally for the sake of winter provender. The less rugged and less exposed parts are more occupied in the culture of corn; and the banks of the Clyde, between Hamilton and Lanark, with orchards.

3. Gardens and Orchards.

Glasgow is abundantly supplied with the common culinary vegetables from market gardens. Orchards are chiefly found in two districts in Scotland, in Clydesdale, and the Carse of Gowrie. "The Clydesdale orchards lie mostly between the bottom of the lowest fall of the river, and the mouth of the south Calder. They are chiefly of apples, with a mixture of pear trees, and some plums. Cherries are more rarely cultivated, being much subject to the depredations of birds. Few of the orchards are large, but many small ones are planted up and down the country. The whole may cover 540 acres or upwards, and are on the increase. The produce is very precarious, the fruit being frequently destroyed in the blossom, by spring frosts and caterpillars. The value of the fruit is not always in proportion to the number and size of the trees. Those who cultivate the ground around the trees, taking care not to injure the roots, and giving manure from time to time, have finer fruit, and a much greater quantity in proportion, than those who do not. Much also depends on adapting the trees to the soil and exposure. These orchards are mostly planted on very steep hanging banks, and on such they have

been found to succeed better than on plains, as subterranean water flows most quickly away. Most of them stand on soils greatly cohesive, and on such the trees have been supposed to be surer bearers than on open sandy soils: yet there are instances of orchards, on friable and gravelly soils, uncommonly productive. Plum trees are generally planted round the verge of the orchard, and are profitable, not only for the fruit they bear, but for sheltering the other trees. The depredations committed on the orchards are become more frequent and daring, as the manufactures of the county have increased, and are a great discouragement to this species of cultivation, particularly that of small orchards, which cannot defray the expense of watching in the night."

Besides the larger fruit, great quantities of gooseberries and currants are cultivated, and, when well managed, are said to pay very well. The gooseberry and currant trees are dug around annually, kept on a single stem, and dunged every second year.

Copsewoods, or native timber trees, are not abundant; the oldest trees are on the Clyde, in and near Hamilton Park and Bothwell Castle. Many new plantations are forming in every part of the county.

4. *Live Stock.*

Cattle a mixed breed; the Ayrshire beginning to become general. Oxen formerly employed in labour, and still used by a few of the amateurs in spite of the better sense of their tenants and bailiffs. Few sheep kept, excepting on the mountains, where the black-faced sort prevails.

The *daught horses* of Clydesdale have long been in high estimation. Dealers from different parts of England come to the Glasgow and Rutherglen markets to purchase them, and prefer them to the Derbyshire blacks. Those of the upper ward, where the greatest number are bred, are esteemed the best. The native breed began to be improved by crosses from England and Flanders about 1760.

The *Lanarkshire breed of horses* vary in height from 12 to 18 hands; but from 14 to 16 hands is considered the proper size. "His general aspect (*fig. 1127.*) is stately, handsome, and dignified. He is round, fleshy, well proportioned, strong, and heavy, without being coarse or clumsy. His countenance is sweet and agreeable, yet lively and spirited; and his motions are steady and firm, but nimble and alert. His head is in due proportion to his body, rather small than large, no way clumsy, and not so full and prominent below the eyes as some of the English breeds. His nostrils are wide, his eyes full and animated, and his ears erect. His neck is neither long nor slender, but strong, thick, and fleshy, with a good curvature, and the mane strong and bushy. He is broad in the breast, thick in the shoulders, the blades nearly as high as the chine, and not so much stretched backwards as those of road horses. The arm tapers to the knee. The leg rather short; bone oval and strong, but solid and clean. The hoof round, of a black colour, tough and firm, with the heels wide, and no long hair on the legs, except a tuft at the heel. The body round and heavy; the belly of a proportional size, neither small nor large, and the flank full.

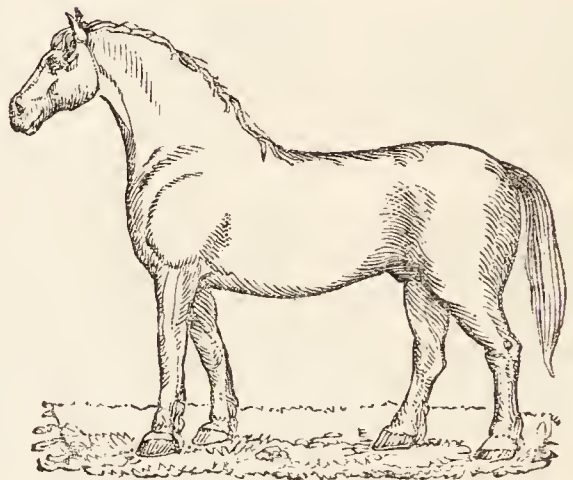
The back straight and broad, but not too long; the loin broad and raised a little. Hucks visible, but not prominent, and but a short space between them and the ribs. The sides, from the shoulders to the hip, nearly straight; the thighs thick, and meeting each other so close under the fundament, as to leave only a small groove for the tail to rest on. The tail strong, stiff, heavy to lift, and well haired. A large sheath (*vagina*) is considered to be one of the marks of a good horse, and a small one the reverse." *Aiton*. They have been much improved of late, and are still improving, especially in size and weight.

Hogs. "A kind of Jewish abhorrence of swine seems to have taken place, about the rigid times of the Reformation, in the western counties of Scotland. They were unclean beasts; it was sinful to eat their flesh, and neither creditable nor profitable to keep them; and though these prejudices are now pretty much worn out, pork is not yet, in general, a favourite food, and, of course, the number of hogs kept and fed are not considerable."

5. *Political Economy.*

The roads are in many places bad, but have lately been improved; though the materials be good and abundant, the wet climate is much against them. There are several canals, the river Clyde, navigable to Glasgow, and some railways. The manufactures and commerce of Glasgow are of great extent and well known. There is a corresponding agricultural society there, and some minor societies.

1127



7843. DUNBARTONSHIRE. 147,300 acres of exceedingly irregular surface, in two parts, distant from each other six miles; possessing little agricultural interest. The arable lands are of very limited extent, and lie chiefly on the banks of the Clyde and Leven: the greatest part of the county consisting of lofty mountains incapable of cultivation. Coal, lime, freestone, and ironstone abound, and are extensively worked. There is also ochre, schistus abounding in alum pyrites, which are made into coppers, and a large quarry of blue slate. Lochlomond is well known for its scenery. (*Whyte and Macfarlane's Report, 1811.*)

1. *Property.*

Two large estates; one exceeds 3000*l.* a year. One third of the county under entail, which greatly retards its improvement.

2. *Buildings.*

More than a common share of elegant villas and gentlemen's houses. The most magnificent is Roseneath, the Duke of Argyle, built by Bonomi, in 1803 *et seq.* It is 184 feet long, and 121 in breadth, with two magnificent fronts, both ornamented with columns of the Ionic order. On his Grace's farm, which is cultivated in a very superior style, there is also a large set of farm offices, surmounted with a high tower. Common farm-houses and cottages formerly very wretched, beginning to improve, but the progress slow. Dunbarton bridge 300 feet in length, and twenty-five feet high in the centre.

3. *Occupation.*

Average extent of arable farms fifty acres; sheep, or mountain farms, average 600 acres. Farmers men of limited education, without capital, and implicitly following the practices of their forefathers. There exists among the labouring class in this district an inveterate attachment to the possession of land. When a young man is disposed to marry, he looks out for a small farm, takes it at an extravagant rent, stocks it on credit, and draws from it a scanty subsistence, while at the end of his lease his effects are often unequal to pay the debt which has accumulated during its currency. In fact the feudal state of society has not entirely disappeared in this county. There were lately, on many estates, and are still on some, farms let to three or four tenants, as conjunct leases, to be cultivated by their united, or rather discordant exertions. Lands always let on lease, seldom for a shorter period than nineteen years.

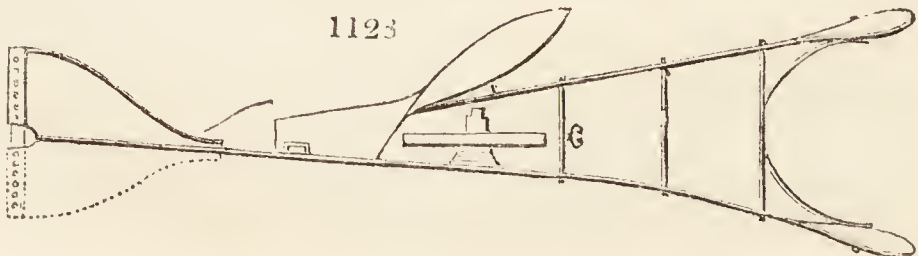
4. *Implements.*

Curved harrows of a semicircular form are used by the best farmers for dressing their potato ridges. The diameter is equal to the distance between the drills or ridges, generally near three feet; and they are used, before the young shoot of the potato springs, to dress the surface of the ridge, and destroy any weeds which may have begun to appear. The highland hand-harrow is still in use in some corners of the highland district. It is about two feet long and fifteen inches broad, consisting of three bulls, and as many cross bars, with twenty-seven teeth and two handles bent, like a hoop, with which it is wrought. It is employed on bits of land which have been dug with the highland spade, either on account of their being too steep to be tilled by the labour of a horse, or from their consisting of a number of small corners among rocks and large stones, to which a common harrow could not find access. Wilkie's wheel plough, with a shifting muzzle (*fig. 1128.*), is used to clear water-furrows on wet lands, and also for the common purposes of ploughing strong clays when wet; the muzzle being set so as both horses may walk in the furrow.

5. *Enclosing.*

Gentlemen who pay particular attention to their hedges never allow them to be cut with shears. In place of that implement a hedge-knife is used, with a short and slightly curved blade, thick in the middle, and tapering to a thin and very sharp edge on each side. By cutting always upwards, the twigs are cut clean over without being bruised or cankered, and the hedge is kept, of what is universally allowed to be the best shape, broad and bushy at the bottom, and contracting to a sharp ridge at top.

1123



6. *Arable Land.*

Potatoes cultivated better than any other crop in the county, and with the greatest success. They are planted on every variety of soil, and thrive even on the stiffest clays where there is a sufficient declivity to carry off the surface water; but a gravelly loam suits them best: about twenty tons of manure per acre is the common dressing. Drilling and dibbling are the common modes in the lowlands, and by large beds in the uplands; and produce twelve tons, but eighteen are frequently obtained.

7. *Grass Land.*

Some bog meadows, but no others; some pasture fields round gentlemen's houses, but none on lowland farms; mountains wholly in natural pasture, moss, heath, bog, and moor.

8. *Woods and Plantations.*

Copsewoods form a very important and prominent article in the produce of this county. They cover some thousands of acres of soil which would otherwise be altogether or nearly useless, and yield an income to the proprietors little inferior to what they derive from their best arable land. The steep sloping banks of Loch Lomond and Loch Long, where the bases of the mountains run into the lake, are in many places covered with them. The thin dry soil which appears in small patches among the rocks seems to be particularly adapted to the growth of oak coppice, which, from its superior value, is chiefly encouraged in such situations, while the moister and more unfavourable spots are allowed to be occupied by less valuable trees. These are chiefly ash, yew, holly, mountain-ash, birch, hazle, aspen, alder, crab, thorn, and willow. The seven last kinds are considered inferior in value to the rest, and commonly known by the name of barren timber.

Copsewoods are cut from the twenty-second to the twenty-fourth year; after the latter period the bark of oak becomes hard and corky, and of less value to the tanner.

Plantations very generally formed on the uplands. 1000 acres planted at Luss previously to 1794. The Duke of Montrose, a great planter in Stirlingshire, and partly in this county, allows 200 Scotch pine, 400 larch fir, and 1000 hardwood trees, to an acre; prefers oak plants of several years' growth; and after they have been established several years, cuts them down, when they push long and strong shoots. Plants by stellate slits, as already described (5955.), as pits in a retentive soil only serve as a receptacle for water. Firs, pines, and all trees now regularly pruned. In the Isle of Skye, Lord Macdonald planted, in 1821, 47,500 trees, and received the honorary premium of the Highland Society of Scotland. (*Trans. Highl. Soc.* vol. vi. p. 258.)

The finest tree in the county is an ash in Bonhill churchyard. Its trunk is about nine feet high, and, where smallest, upwards of eighteen feet in circumference. Of the three principal arms into which it branches, the largest is eleven, and the smallest near ten feet in circumference. The branches spread in every direction with uncommon regularity, covering an area of near

100 feet in diameter, and the general aspect is singularly venerable and majestic. There are no data from which its age can be conjectured. Nearly 100 years ago it was remarked by Marsham of Stratton, near Norwich, a celebrated planter, as one of the first ashes he had seen; and a tendency to decay in some of the boughs seems to indicate that it has stood there for several centuries.

Yew trees and hollies abound on the banks of Loch Lomond. A yew at Rosedoe is twelve feet round, and very high; one at Stockintibbert twenty-eight feet round, and the top spreading in proportion.

9. *Improvements.*

Some proprietors have drained bogs, and rendered them tolerable meadows; and drained and planted moors. Mosses sometimes burned, the ashes ploughed in, and the land cropped with oats, &c.

Irrigation, by means of the rills on the hill sides, tried in some places with success.

Embankments have been made on a small scale, and some of considerable extent might be formed with success.

10. *Live Stock.*

Highland cattle from Argyshire in general use; but little feeding, dairying, or breeding of this species of stock. Sheep of a small black-faced kind bred in the county, to the extent admitted by the upland pastures. Horses, a small hardy breed.

Hogs increase as the prejudice against pork disappears. 200 fallow deer occupy two of the largest islands of Loch Lomond. The stag, or red deer of the mountains, has disappeared since the introduction of sheep. A few roes still inhabit the woodlands.

Bees common.

11. *Political Economy.*

Manufactures of iron, glass, cotton, paper, alkali; printing and bleaching works, &c.

Window glass manufactured extensively, and equal in quality to any in the kingdom. Pay 50,000*l.* a year of excise duties; employ 10,000 tons of shipping, and consume 1200 tons of kelp. The distillery of pyrolignous acid at Milburn employs about seven hands, and consumes daily a ton of small timber, chiefly oak, from which the liquor, a kind of coarse vinegar, is extracted. The process beautifully simple. A number of iron ovens, or retorts, are placed in a row, and filled with the timber cut into small pieces. A fire of coals or charcoal is kindled in a furnace attached to each, and by its heat forces the acid to fly off in the form of vapour. This vapour is conducted by a small tube, proceeding from each retort, into a refrigeratory, or long metal pipe, on which a jet of cold water from above is continually falling. Here the acid is condensed, and runs from the end of the pipe in a considerable stream, of a reddish brown colour. Besides the liquor thus procured, which is employed in mixing colours for the calico printers, there is a considerable quantity of tar and charcoal produced during the process, the value of which is esteemed equal to the expense of fuel.

7844. STIRLINGSHIRE. 450,560 acres, much diversified by rivers, mountains, woods, and valleys, containing some rich alluvial soil, extensive peat-bogs or mosses, and some bleak hilly districts. The culture of wheat and beans is the chief agricultural feature. Potatoes first cultivated in the fields in this county by Prentice, a farming gardener at Kilsyth. (*Belsche's General View*, 1796.)

Principal river the Forth, and mountain Benlomond; the latter a cone, upwards of 3262 feet high, of sheep-walk, belonging to the Duke of Montrose.

Lime, coal, ironstone, granite, whinstone, and freestone abundant.

The *carse lands* constitute one of the most remarkable soils in the county. They lie in a low situation on the banks of the Forth, and extend about thirty miles in length and two in breadth, at an average. They are elevated from ten to twenty-five feet above high-water mark, and a small portion of them in some places is overflowed at times by the river. The soil is universally allowed to be the alluvion deposited by the Forth and its tributary streams, and consequently to be the spoils of the higher grounds, through which the river takes its course. It chiefly consists of a hazel-coloured clay, a small quantity of sand, and a pretty large mixture of once organised matter. In some places are patches of till of various colours; but not a stone, so large as to obstruct the plough, is to be found. The

soil of the best quality; when dug first from the natural bed is of a bright blue colour, and of a substance resembling the richest soap, and sometimes even serves as a substitute for fuller's earth. In many places the clay is excellently fitted for making bricks, tiles, and a coarse kind of crockery ware. The depths are from five to fifty feet. The subsoils are various, as a stiff brick clay, hard till, and sea-shells in a natural state. These beds of shells are from a few inches to four yards in thickness; they are chiefly large oysters, with a mixture of cockles, whelks, and some other shells at present found in the frith. These lands are in farms from fifteen to 100 acres each. In the higher parts of the county the extent is from twenty to 1000 acres.

Of *moors* above 90,000 acres.

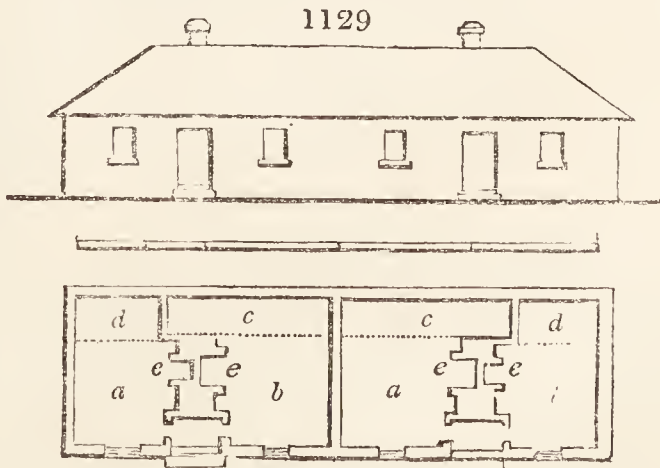
Coppice woods extensive, and plantations considerable.

Carron iron-works of great extent, and well known. Large cattle fairs held at Falkirk. Chief commerce the shipping of Carron articles for London and other places.

7845. WEST LOTHIAN or LINLITHGOWSHIRE. 71,580 acres of gently varied surface, without hills or mountains; clayey soil, and rather cold and variable climate. The minerals are coal and lime in abundance; freestone, whinstone, and some lead and iron, but the latter are not now worked. The coal at Borrowstonness has been worked upwards of five centuries. In an agricultural view, the county may be considered on a par with Mid-Lothian. (*Trotter's General View*, 1811.)

Property is in the hands of about forty proprietors. Lord Stair is supposed to have introduced the culture of clover, turnips, and cabbages at Newliston, in this county, as early as 1720; and also the Rotheram plough, for which purpose he sent a mechanic to England, to acquire the art of constructing them. A hay drag, of a very simple but convenient construction, is used in this county. Plans of a more decent form of cottages (*fig.* 1129.) are given than are to be found in some reports. Each cottage consists of two rooms (*a, b*); the one to be used as a kitchen has a space for two press or close beds (*c*), and in the other room there is a space for one bed (*d*); in each room is a cupboard (*e*), but no closet, which is a great defect.

The contrivance for making horses draw equally in threshing-machines (2786.), was invented in this county, by G. Henderson, of Bonhard. The culture pursued is the East Lothian husbandry on the clays, and the Perthshire on the turnip soils. The chief commerce is from the port of Borrowstonness, and there is scarcely any manufactures, unless spinning, knitting, and tambouring in private families may be named.



7846. CLACKMANNANSHIRE. 30,720 acres, principally of carse land, on the north bank of the river Forth; but partly of hilly district, belonging to the Ochills. (*Erskine's General View*, 1795.)

The carse lands are very fertile; but part of the hilly and moory district of little or no value. The agriculture is similar to that of Stirlingshire. After the invention of the threshing-machine, one of the first was erected at Kilbagie, by George Meikle, in 1787; it is driven by water. A curious source of manure is found in this county. The moss floated down from Blair Drummond (2189.) accumulates in the bays, and is mixed as deposited with the sea-weed driven on shore by the tide. This moss and weed is taken out and fermented with a

small proportion of stable dung; or the farmers spread it over their cattle-yards, and it forms most excellent manure. Thus, what is a complete hindrance to improvement forty miles distant, is brought here by the river at no cost, and forms a most valuable addition to the resources of the cultivator. Till 1760, no wheat was grown in this county, though it appears by old abbey rentals that wheat was paid as rent at Cambus Kenneth so early as 1147. Now wheat enters into almost every rotation.

7847. KINROSS-SHIRE. 47,642 acres, of varied surface, but generally low. There are extensive nosses and muirs, and not much rich soil. Their agriculture is mixed, and of no great interest. (*Ure's General View*, 1795.)

Lochleven occupies 3508 acres; three small streamlets run into it, and the difference between its highest and lowest surface, at different seasons, is three feet. The trouts of this lake in high esteem; those of the river Leven larger, weighing five pounds and upwards.

Dr. Coventry, the learned Professor of Agriculture in the University of Edinburgh, possesses an estate in this county,

where he sets an example of knowledge, industry, and good management to all his neighbours.

Adam, of Blair Adam, the son of the celebrated architect, the most extensive improver in the county; draining, enclosing, planting, more especially the larch and Scotch pine, and building commodious cottages, extensively and judiciously pursued.

7848. FIFESHIRE. 322,560 acres, exhibiting almost every variety of surface and soil, from the mountain to the plain, and from gravel to moss. The climate is generally mild, owing to the surrounding waters; and what adds to the value of the county, both for culture and for the formation of country-seats, it is rather drier than that of other counties equally far north. The agriculture is mixed, and may be said to excel both in the corn and cattle department. The reverend reporter displays more than the usual share of adulatory phraseology for that "highly patriotic individual, Sir John Sinclair," our "gracious Sovereign," the Board of Agriculture, and the Government, "chalking out to the people a path by which they may rise to opulence and consideration." (*Thomson's General View*, 1800.)

1. Geographical State and Circumstances.

Coal, lime, and the usual rocks abound; ironstone and lead and copper ore abound, but none worked. Nearer Burntisland, upon the shore, and also in some other parts of the county, there are quarries of hard stone, of a dark colour, with the peculiar property of resisting the force of fire. It will endure for many years, without being wasted or broken, though exposed to the most intense heat. On this account it is used for the soles of ovens, and for the sides of chimney grates. Common and fire bricks manufactured of an excellent quality. (*Thomson's General View*, 1800.)

2. Property.

Estates moderate; largest, 8000*l.* a year.

3. Buildings.

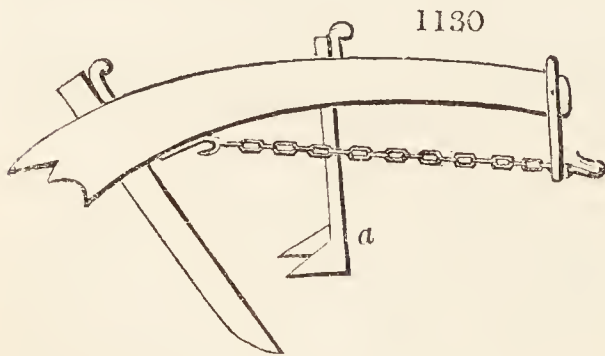
Few counties so richly studded with noblemen and gentlemen's houses; about a hundred enumerated as deserving of notice. Many magnificent buildings in ruins. Religious houses, castles, and Falkland Palace. Farm-houses and cottages formerly very bad, now greatly improved, and superior to those in most counties.

4. Occupation.

Farms from 50 to 500 acres of arable lands, and some of mountain pasture twice as large. Some of the largest and best farmers are men who have emigrated from other counties to this less improved district; but the greater number are sons of local farmers, and not a few farms have been in the same family for several generations. The reporter is an advocate for corn-rents, a mode first revived in this county with the improvement of not taking the corn, but paying in money, according to the average prices. Leases for nineteen years; some formerly for one or more repetitions of the period; in general the restrictions reasonable, for the managers of estates in this county are generally resident factors, and not Edinburgh lawyers.

5. Implements.

Ploughs with convex mould boards preferred for loose soils, especially when in a wet state; they free themselves more readily of the earth, and make a neater furrow. An addition to the plough, called a ridder (*fig.* 1130. *a.*), adopted in some places, and found to clear away the stubble from the coulter.



7849. PERTHSHIRE. 4,068,640 acres, almost every where mountainous, but with intervening vales of strong clayey soils, fertile in corn; some gravelly tracts, and many mosses, bogs, and moors. The mountains on the southern side of the county, where they are less high, are covered with pasture to the summits; those in the northern parts with pasture, heath, and copse. The minerals are coal, lime, freestone, slate, whinstone, granite, &c. the metallic ores, iron, lead, and copper, neither of which are at present worked. This county serves to divide that part of Scotland on the south, which is generally adapted to the raising of grain, from that of the north, which, with few exceptions, is more fitted for pasture. It also divides those parts of the kingdom on the north, where firs abounded in former times, and are still found in the mosses, from those in the south, which carried oaks and a variety of other wood, but no natural firs. It is also the general boundary, in regard to coal and granite, though both are found to a moderate extent, the former in the north, and the latter in the south. The husbandry of Perthshire is noted for its clay, or carse land culture, and for its plantations of larch trees. Its great improvers

6. Grass.

One fifth of the county inaccessible to the plough, and in store sheep and cattle pasture; some bog or coarse rushy meadows on peat, and a few spots of good alluvial meadow.

7. Gardens and Orchards.

The remains of an orchard at Lindores, but none of modern formation. Some market-gardens near the towns, but most of the inhabitants have gardens of their own. Some good nurseries. Sang, an eminent nurseryman, and manager of gentlemen's plantations,—a valuable man to the county,—has introduced an excellent system of planting, pruning, and draining. Some of the first private gardens in Scotland are in this county, as that of Keith, Wemyss Castle, &c.

8. Woods.

Not extensive, but young plantations very numerous and well managed. More cedars and rare sorts of trees in this county than in any other.

9. Live Stock.

Black cattle of Fife long distinguished. The reporter has heard an English dealer say, that a Fife bullock of forty stone will bring an equal, and often a higher, price at the London market than an English bullock ten stone heavier, and equally fat. A good Fife cow will give from five to seven gallons of milk per day, from seven to nine pounds of butter, and from ten to twelve pounds of cheese per week, tron weight, for some months after calving.

Breweries, distilleries, flour and barley mills, frequent. The linen manufacture extensive. Salt made from the sea. Tanneries, vitriol, &c.

The Fife Farming Society and the Inverkeithing Club, supported chiefly by farmers, are considered useful institutions. The first was formed about six years ago, and at present consists of nearly 200 members. The principal objects aimed at by this institution are, a mutual communication of discoveries and improvements in husbandry; common protection against thieves and depredators who shall unjustly invade their property; and raising a joint stock or capital for the benefit of their widows and children, and of members reduced to distress or indigence. Members pay one guinea at their entry, and half-a guinea yearly. None are admitted but men of good character; and such members as shall be found guilty of crimes and misdemeanors punishable by the laws of the land, are liable to expulsion, and a total deprivation of all benefit from the Society's fund. No member can draw any thing from the fund till it amounts to 500*l.*; neither can any one be entitled to any allowance until five years after his admission. The allowance fixed for a member fallen into distress or indigence, is thirty shillings per quarter; but this allowance is granted upon the express condition, that he has not brought the distress upon himself by drunkenness, or any other kind of disorderly conduct. And during the time he is receiving the allowance, if he shall be found guilty of dissolute or immoral behaviour, it is put in the power of the managers to deprive him of it. The widow of a member is allowed twenty-five shillings quarterly, so long only as she remains his widow, and maintains a good character. And the children, when no widow is left, are entitled to draw the half of what their father contributed. If a member shall die, and leave neither widow nor children, his next heir, or whoever shall be appointed by him, shall be entitled to the half of what he has contributed, after deducting a proportional share of the expenses incurred by the society since his entry. This society is, at present, in a very respectable and flourishing condition.

have been, or are, Lord Kaimes, the Duke of Athol, and Lord Breadalbane. (*Dr. Robertson's General View, 1813.*)

1. Property.

Estates are of all sizes, but the greater number large. The management of the great estates was uniformly committed in former times to the factor or chamberlain; but agriculture has become so much the amusement of the country gentlemen, since the middle of the last century, that many of the proprietors, besides the general superintendence of their estates, have a farm in their own possession, which they manage by an overseer. Many of our improvements in agriculture are suggested by the gentlemen of the army, in consequence of their remarks on the practice of other countries. The gentlemen of the law, during the recess of their courts of judicature, turn much of their attention to the cultivation of their estates; and their habits of application to the former study, quickens their ardour, and ensures their success in pursuit of the latter.

If the property be extensive, besides an overseer on the landlord's farm, there is generally a factor or steward, and sometimes two or more are appointed to manage the more distant parts of the estate. In these cases, unless the landlord have a turn for business, he is apt to lose sight of the detail of his own affairs; and if he be indolent, he has a good apology for neglecting his interest, because he pays another person for taking that charge off his hand. The prosperity of the estate, and the comfort of the tenants, depend in these cases very much on the disposition of the factor.

The boundaries of estates are marked according to the nature of the country. In the valleys of the highlands, different properties are separated either by substantial stone-walls without mortar (provincially dry stone dykes), or by a river, or a brook, or a range of rocks, or some other natural limit. The lower hills too are sometimes bisected by these walls; but more generally by bounding stones, fixed in the ground, and set up singly; in other instances, if the stones be small, they are piled in heaps. The higher mountains are frequently divided in a similar manner, especially when different proprietors occupy the same side; but when they occupy different sides of the same ridge or general line of mountain, as commonly happens between parallel glens, their properties are determined as wind and water divides, which means the line of partition on the top of the mountain between the windward and lee-side, or as it is still more nicely marked by the tendency of rain water, after it falls upon the ground.

A great proportion of this county is freehold. Many of the small proprietors hold of a subject superior. When a great baron in the feudal times had occasion to borrow money, he had recourse to wadsetts, or feued off a part of his property at a quit-rent, which was greater or less, according to the amount of the premium that was paid in hand. The wadsetts are paid up; but the feus, being irredeemable, remain.

2. Occupation.

Arable farms from 30 to 500 acres. Farms in the mountains large, and their extent generally defined by miles. Leases seldom shorter than nineteen years' endurance. Rent, in a few instances, partly in money and partly in the money value of corn, on an average of two or three by-gone years, according to the modern system. The culture requires scarcely any remark, since there are only two kinds of aration in Scotland, that of the clay soils of East Lothian, in which a fallow and alternate corn and green crops are introduced; and that of Berwickshire, which substitutes turnips for fallow, and allows from two to five years of pasture, according as the soil is weaker or stronger as resting crops. A full account of the clayland culture has been given by Donaldson. In the mountainous region, cattle chiefly, and sheep to a certain extent, are bred and sold for feeding in the low arable districts, and sent to the south of Scotland and England.

3. Gardens and Orchards.

In the Carse of Gowrie, a number (perhaps thirty) of orchards of apples and pears, the fruit of which is sold to the neighbouring towns. A few other parts of the county adapted to open orchards, as the banks of the Tay, Earn, &c. In the valleys of the highlands, geans and cherries abound. The trees thrive well, live long, and carry fruit of the finest flavour and most savoury taste. The cream-coloured cherry of Ardvorlich, and the black gean of Castlemenzies, are highly esteemed in respect of beauty and relish.

4. Woods and Plantations.

The highlands of Scotland formerly covered with wood, as the trunks of oaks and firs in the mosses, from that of Moss-Hunders, near Stirling, to the bogs of Sutherland and Caithness decidedly prove. Planting did not become general in Perthshire till after the middle of the eighteenth century. The county is now distinguished by its extensive tracts of larch, common pine, and other trees, and by the enclosure of oak, hirsch, and hazel; copses and woods formerly left open to the browsing of deer and cattle. Different accounts have been given of the introduction of the larch into this county. Dr. Robertson states it as "said to be brought to Athol, from Carniola, by one of the Dukes of Athol." According to others, the first plants were obtained from a nursery at Edinburgh, and planted at Dunkeld in 1741, having been previously introduced into Scotland, by Lord Kaimes, in 1734. (*Encyclopædia of Gard.* 2d edit. 7053.) Some of the first planted larches in the low grounds, near Dunkeld, have grown to the height of 120 feet in fifty years, which gives an average of two feet four inches and a quarter a year. It is stated by the Duke of Athol, in a communication to the Horticultural Society, made in June, 1820, that on mountainous tracts, at an elevation of 1500 or 1600 feet, the larch, at eighty years of age, has arrived at a size to produce six loads (500 cubic feet) of timber, appearing in durability and every other quality to be likely to answer every purpose, both by sea and land. (*Hort. Trans.* iv. 416.)

"The largest larches in Perthshire, or perhaps in several counties around it, are at Monzie, the seat of General Campbell, which measure five feet in diameter, and about fifteen in circumference. There are larches of a great size at Blair Drummond, Gleneagles, Rossie, and many other places in Perthshire. Posts of larch, which had been put into a moist soil about fifteen years ago, seemed still to be fresh and strong. It is only of late that this tree has been generally planted, and its excellence known in this country. It is the most rapid in

its growth of any tree we have, and the most valuable species of the pine. It is closer in the pores, has fewer knots, and the wood is more durable than the common pine, and withal it increases double the number of cubical feet, in any given time; which is a singular property. It may vie in growth and profit with the Huntington willow, which has been said to buy the horse, before any other tree could buy the saddle."

There is a natural *fir wood* on the south side of Loch Rannoch which covers 2566 acres. One formerly existed on the Breadalbane estate, but there are now only a few gleanings.

There are more *oak woods*, and of greater value, in this county than in all the rest of Scotland. The counties of Dunbarton, Argyle, and Stirling, come next to that of Perth. The copse of oak is cut once in twenty-four or twenty-six years. A few spare trees of the most promising appearance and of the best figure are left at proper distances, from one cutting to another, and sometimes for three or four cuttings. The straightest are generally spared, without attending to this circumstance, that crooked oak is more eagerly sought after by ship-builders, and brings a higher price, than oak which is straight. Yet as coppice wood is the object, straight trees injure it least. Scotch oak has been found in general too close in the grain to bend into planks for the sides of ships, and even for the same reason it is found to snap when used as ribs to a ship: its closeness in the grain is the effect of slow growth, owing to frequent checks by early and late frosts.

Before agricultural improvements were so well understood as they are of late, or occupied so much of the attention of all ranks in this country, many moorish tracts of lands were deemed incapable of cultivation, or of making a return in any other way equal to their being planted. Proprietors, even in the Carse of Gowrie, and in the Stormont, being actuated by this principle, about thirty years ago, planted the waste lands of their estates with Scotch firs. They have now found that this soil, by being wrought, will make good arable land, and will be more profitably employed in tillage. Some thousands of acres have accordingly been cleared; the plantations rooted up; and the soil subjected to the plough, which now lets at a progressive rent, in some cases amounting already to twenty shillings the acre. Betwixt Cupar, Angus, and Perth, a tract of thirteen miles, the plantations on two thousand acres, upon both sides of the public road, have been grubbed up; and the operation is still going on, both there and in other places. So powerful is the principle of imitation, that we all go frequently one way until we have gone too far. All men can imitate example, but all men cannot reason so far as to form a principle of action to themselves. In a certain degree this operation is salutary; but if carried to excess, it will leave the face of the country naked; and, perhaps, in all cases, the cost is not counted, nor the balance fairly stated between the plantation and the produce arising from some poor soils by an arable system; yet it must be admitted, that no trees are equal in value to corn and grass, either to the landlord or the public, where the cultivation of these can be prosecuted with success.

5. Wastes.

The mosses and moors of this county are very extensive, and great and successful efforts have been made for their improvement. The most remarkable is that of Kincardine moss, commenced by the late Lord Kaimes, and already described. (2153.) Draining, paring and burning, irrigating, embanking, and all the different modes of improving land, have been practised; and some, as draining and burning, to a very considerable extent.

6. Live Stock.

Breeds of cattle very various; none peculiar to the county; Angus, Fife, and Argyle herds common among the farmers. English, Ayrshire, and most of the approved breeds of the south tried by the proprietors. Breeding is the chief object, and next the butter dairy.

Sheep. The ancient breed of sheep in this county were the white-faced. They were few in number, compared to the flocks at present; and in the highlands were housed in cots every night in winter and spring. About forty years ago, the black-faced or mountain breed was introduced from the south, and bought in, either when lambs, or at a year old. Their numbers have increased beyond all expectation, since that time, over the whole highlands of Scotland. In gentlemen's enclosures we see different kinds, according to their fancy, or the superior profit expected from one kind more than others.

Horses. The original breed were ponies, twelve to thirteen hands high, and too light for two-horse ploughs. Four of them were used abreast, as is still the case in some remote places. In the Carse of Gowrie and other lowland districts oxen were employed to draw the plough, till about 1779; and the horses were only employed to harrow in the seed, to carry out the dung, and bring home the corn to the stack-yard. When oxen were discharged from the plough, it became necessary to purchase larger horses than were then bred in the county; and the markets of Glasgow, Falkirk, Stirling, and Perth were resorted to for that purpose; which practice still continues.

At present some Northumberland stallions have been procured by proprietors, and lent to their tenants in order to raise an improved breed.

Swine. The prejudice against swine's flesh was such, that, not many years ago, no highlander would touch it; that is now fast wearing off, and the culture of swine extending.

There is a *rabbit* warren at Dunkeld, and red deer and roes in one or two places. There are also three or more kinds of fallow deer in the county.

Bees much attended to, and found profitable. Paterson of Castle Huntley sows mignonette for his bees, which gives the honey a most delicate flavour. Rosemary does the same. The honey of beans is pale; the honey of heath brown. Their flavour is also different.

7. Political Economy.

Roads wretched before 1745: still only bridle roads in many places of the interior. No canals; salmon fishery to a great extent on the Tay. Linen manufacture, bleaching, and various other manufactures and public works. The principal salmon fishery is rented by Richardson from different proprietors, and for the sum of 7000*l.* a year. There are five others, which produce from 100 to 200*l.* a year.

7850. ANGUS or FORFARSHIRE. 532,243 acres, one half, or more, of clayey and alluvial lowlands, and the remainder mountain pasture, moor, and bog. The climate cold, moist, and variable. It is both an agricultural and manufacturing county, and in respect to antiquities, facilities of further improvement, natural productions, &c. of great interest. The botanic family of Don are of this county. A most valuable report has been furnished by the Rev. James Headrick, and is the last of the Scotch reports which has been published. (*Headrick's General View*, 1813.)

1. Geographical State and Circumstances.

The *Grampian mountains* abound in granite, which contains topazes, or rock crystals. Quartz, mica, porcelain stone, lead, limestone, slate, jasper, porphyry, breccia, and shell marl occur in various places. The Loch of Forfar abounds with shell marl, which is taken out by scoops, and thrown into boats, by which it is conveyed to the shore. The scoop consists of a large iron scraper, somewhat similar to the Dutch hoe, which has a long wooden handle fastened into it, and a bag of strong leather fastened by whipcord around its rim. The bag is perforated by small holes, to allow the water to drain off, and has a thong at its bottom, by which it can be turned over, and its contents discharged into the boat. After the boat is firmly fastened by anchors, extended from each end, one man forcibly presses down the scoop to the bottom, by means of a long pole at the stern of the boat, while another man, by means of a windlass, or wheel and axle, fixed in the opposite end of the boat, drags the scoop along the side of the boat, by a rope attached to it, and then raises it up to the boat's side, where the contents of the bag are emptied into the boat. When the boat has received her load, the marl is thrown out upon a wooden platform at the side of the loch, to drain.

Sandstone flags are very abundant in the neighbourhood of Arbroath, and are quarried and exported in great quantities. Principal quarry, Carmylie; the flags rise from three to six inches of any portable dimensions. They are called slate-stone flags, but are in fact sandstone in plates, coated with scales of mica or tick, of a greyish blue colour; and this mica occasions their easy separation from each other. With very thin plates, called slatestones, houses are covered; they are laid in "plaster lime" or moss (*Sphagnum palustre*), but they seldom make a roof that is water tight, and slate is now considered cheaper. A most valuable property of the flagstone is, that when laid as pavement on wet soil, they never show this on their upper surface; so that they are excellent for paving kitchens, passages, paths in hot-houses, &c. Coal searching for, at the time the report was printing, but with no great hopes of success, the district being considerably out of the boundary of the known coal fields of Scotland. No minerals worked: various chalybeate springs. No rivers, but a number of streams that are of moderate size. Considerable sea, and some salmon, fisheries. The herring fishery has been tried in the open sea, and considerable quantities taken in June, July, and August. Those earliest taken were plump and fat, which shows that all former theories concerning this most nutritive and abundant of all fishes are erroneous, and how much it imports the interests of Britain, that the herring fishery should be conducted according to the Dutch method, in the deep sea, and, as in the Isle of Man, from May to September. Garvies or sprats, and spirrings or smelts, abound in the Frith of Tay. The sprats resemble herrings, though of smaller size, and different flavour. They are taken in great quantities at Kincardine, and other places near the junction of the Forth with its estuary, by nets or wicker traps, sunk in the ebb of the tide. The smelts are smaller than the sprats, and when fresh, emit a smell resembling that of green rushes; but when fried, make delicious food. They are caught during spring, along the Forth, often as far up as the Bridge of Stirling, by nets in the form of baskets, fastened to the end of long poles.

Haddocks, whittings, &c. cured by smoke, a practice first suggested by Headrick, the reporter, in an essay published by the Highland Society of Scotland. Dempster, of Dunnichen, in this county, first suggested the idea of conveying salmon to London packed in ice. Reporter remembers when servants in the neighbourhood of Stirling used to stipulate that they should not have salmon oftener than thrice a week; now they seldom have them once a year.

Every river is said to have its particular breed of salmon. They have recourse to fresh water, to escape the attacks of seals, otters, and porpoises, and to get rid of the sea-louse, a small black animal, whose attacks seem to inflict upon them excruciating tortures. A few gulps of river water seem either to kill the sea-louse, or to deaden the pain it inflicts. Salmon never remain longer in fresh water than is necessary to effect the purposes which brought them there; but sometimes they are surprised in the rivers by long droughts, and cannot get over mill-dams, and other obstructions which lie between them and the sea. When this happens, they soon get lean and mangy, and die, their bodies covered with white worms. But in fresh water, they take various kinds of bait, and eagerly catch at flies, and hence become a source of amusement to the angler. During autumn, the salmon always run up the rivers to deposit their spawn.

The *spanning of salmon* seems to be a very slow and laborious process; and they get very lean, and even become unwholesome food, while they are engaged in it. The scene of this operation is generally where a stream begins to issue from a stagnant pool, over a sandy bottom. They begin by digging a hole in the bottom, by pushing the sand and gravel before them with their snouts, in the direction of the current, until they raise it into the form of a bank, which checks the rapidity of the current, while it allows the water to percolate slowly. The male seems to exert himself most in this work; and before its commencement, his snout becomes longer and harder than usual, while, before it is finished, it is often worn entirely away. While depositing their spawn, the male and female rub their bellies upon each other; the latter throwing out her roes or eggs, while the male emits among them a milky juice, which seems to effect their impregnation. After one stratum of eggs is deposited in the artificial hollow described, they cover them with light sand, to prevent them from being washed away by the water; and thus they form alternate layers of eggs and sand, until the hollow is nearly filled up. The eggs being dropped into a hollow place, are warmed into life by the sun's rays, in early spring. The fry, being then very small, easily escape from their covering of loose sand, and soon acquire the size of small trouts, and are called salmon fry, or smolts; which seems to be a contraction of *smollets*. The first

flood now washes them into the sea; and they are generally swept from our rivers before the middle of May.

Salmon trout, or grilses, which ascend the rivers towards the close of the fishing season, are by some considered a distinct species of fish; but some Caithness fishers assured the reporter, that they proved by experiment, that grilses are only salmon of one year's growth. (*Rep.* p. 103.)

The *sea trout* resembles the salmon, and frequents all the streams where it abounds.

Fresh water eels, contrary to the practice of salmon, breed in the sea, and thrive and fatten in the fresh-water lakes and ponds. During summer, myriads of their young fry are seen constantly ascending the fresh-water streams, where they keep near the sides, that they may avoid the current. In places where they meet with interruption, such as behind a mill-wheel, they often accumulate in large masses, and frequently make their way up the crevices of the building, or over the dry land, until they reach the stream above, in which they continue their course. The larger eels are caught in this county, while they are descending the streams during autumn, probably to deposit their spawn in the sea.

The observations of the reporter on various other species of fish, and on salmon and other fisheries, are, like every thing which flows from his pen, new and interesting.

2. Property.

Much divided, largest estate 12,000*l.* a year: property, at an average, changes its proprietor every forty years. During the dark night of superstition, a man could take no step respecting his property, or his domestic concerns, without having half a dozen or a score of priests to advise him: and he was obliged to compound for the safety of his soul, and the security of his property, by ample donations to the church. When a man died without granting these donations, it was presumed to be his intention to do so; and what was originally an alms, or favour, was claimed as a right. In our days, a man can hardly venture upon any step of importance without having a posse of lawyers at his elbow; and, after all, often finds himself as far from his purpose as if he had not employed them.

3. Buildings.

Sixty gentlemen's seats enumerated; not many with handsome buildings. Farm-houses and cottages most wretched, and slower of improvement than in most other counties.

4. Occupation.

Farms of all sizes, but chiefly small. On the Grampians, estimated by the number of sheep they will maintain.

5. Implements.

Old Scotch plough still used in a few remote places, and found an instrument well adapted for breaking up waste land that is encumbered with the roots of shrubs, or with stones. At no remote period, it was usual to yoke four or six horses, abreast in this plough. The driver walked backwards before the horses, and struck them in the face to make them come forward. At present this plough is commonly drawn by four sometimes by six horses, which are yoked in pairs, and the driver walks beside them. But, except for the purposes already specified, the plough which was first invented by the late Small, near Dalkeith, and from him named Small's plough, is universally used.

A *threshing-machine*, of a very peculiar construction, adapted to very high falls of water, erected at Howmuir, by Stirling, an ingenious man; but is not yet perfected, and if it were, could never become general.

A *pick* or lever with a tread, used in the same manner as a fork or spade, for loosening hard earth or gravel: in fact it may be called a one-pronged fork.

6. Tillage.

Fallowing general. Seed-wheat washed with a ley of soft soap, to remove the smut. Potatoes introduced to the gardens in 1745, but not to the fields for many years afterwards. The late Dr. Walker, Professor of Natural History in the University of Edinburgh, was in the habit, especially during years of scarcity, of using yams in place of bread in his own family. He cut them into thin slices, and either boiled them over the fire, or dressed them in the frying-pan with as much butter as prevented the pan from burning. When dressed in this way, their taste was very pleasant; and they were used in all cases where bread is commonly used.

7. Gardens and Orchards.

A great prejudice in favour of covering wall trees with nets, to preserve the blossoms from the frost; woollen nets preferred.

8. Woods and Plantations.

Few woods, but many plantations. In the mosses the trunks of large trees found.

9. Rural Economy.

Farm-servants live chiefly on oatmeal, and potatoes and milk. Their breakfast is porridge, which is made by stirring meal among boiling water, or milk, in a pot over the fire, with a little salt; and when it cools it is eaten with milk. Or they use *brose*, which is made by pouring warm water upon meal, in a wooden dish, with a little salt, taking care to stir it well. This too is eaten with milk, or with beer which is furnished in place of milk, when the latter is scarce. Sometimes, when they are in a hurry, they mix the liquid with the meal in a cold state. Their usual dinner is oat-cake, with sometimes butter or skim-milk cheese, and milk. Their supper is the same with breakfast, except that sometimes they use sowens or potatoes, in the place of porridge or brose. Butcher's meat is only used on particular occasions; and fish by those who are near the rivers and the sea-coast.

Much ridicule has been thrown on the Scotch, on account of their immoderate use of oatmeal. This has been represented as inflaming their blood, and producing their favourite disease called the *Scotch fiddle*, and other cutaneous eruptions. But oatmeal is as much used in some districts of England as in any part of Scotland; and cutaneous eruptions are much

more frequent in some of these districts than they are here, where they are seldom or never heard of. The latter ought rather to be ascribed to dirty linen or clothing, than to oatmeal, or any particular species of food. Oatmeal, when it is sufficiently diluted with any sort of liquid, is known to be a laxative aperient, wholesome, and at the same time a strengthening food for those engaged in hard labour. Engineers, who superintend the excavation of canals, have assured the reporter, that those labourers who lived entirely upon oatmeal and milk did a third more work than those who used butcher's meat, beer, and spirits. All of the former saved money, while many of the latter involved themselves in debt. As this sort of work is done by the piece, it affords a fair

comparison, not only of the wholesomeness of oatmeal in promoting health, but of its power in supplying labour.

All families that have a house of their own use tea and wheaten bread; but among cottagers this is a rare and always a ceremonious entertainment, at christenings and other solemn occasions.

Several agricultural societies: the first founded by Dempster of Dunnichen, an eminent improver. An account of the native plants and animals of the county by Don, the celebrated Scotch botanist, who resided at Forfar, possesses great interest for the naturalist. Indeed the whole survey ranks, in this respect, with that of Farey of Derbyshire.

7851. KINCARDINESHIRE or MEARNS. 243,444 acres, chiefly of mountain, but containing about one third of culturable surface. The climate is severe and hilly. The soil is gravelly, mossy, or clayey, and scarcely any where naturally fertile. The only minerals are lime, found in a few parts, and granite, whin, and freestone. Improvements commenced in this county about the middle of the eighteenth century, and have since been carried on with great spirit. (*Robertson's General View, 1795.*)

1. *Property.*

In few hands: largest estate 40,715 acres, the rest in eighty or ninety estates.

2. *Buildings.*

Some old farm-houses still remain, built of stone and turf, and in all respects wretched; but as leases are renewed, new farmeries are erected on the most improved plans, with commodious dwelling-houses. So much cannot be said of the cottages, which have undergone very little alteration in structure, for a long space of time. The habitation of the farmer may have advanced in elegance and accommodation a hundred fold; but the cottager still lives in the same simple kind of fabric as his ancestor did in the most remote ages of civilisation. A cottage built of stone and turf, or more generally of stone and clay, commonly consists, like the ancient farmhouse, of two apartments divided by the furniture. In each of these there is a fire-place and a window. The fire is still without a grate; but the window has two, and in some cases four, panes of glass. The house may be about thirty feet in length, and twelve feet (seldom more) in breadth, in the inside. The walls never exceed six feet in height; and the roof is covered first with thin sods, and next with thatch, carefully renewed from time to time, and tied firmly on with straw ropes. The whole has much the appearance of a low hay-sow. Every cottager has a little garden or kail-yard; and many of them bestow much care, and show no little taste, in its cultivation. Besides raising different kinds of coleworts, cabbages, onions, carrots, &c., for the pot, they frequently have rows of gooseberry and currant bushes, together with roses and other flowering shrubs. Some of them decorate the walls of their houses with honeysuckles, or with ivy; and in some instances with cherry and apple trees.

The furniture of a Mearns cottage consists, in general, of two close wooden beds, which are so arranged as to make a separation between two apartments; one or two wooden chests for holding clothes; a cask for holding meal; a set of dairy utensils; an iron pot or two for cooking the victuals; a girdle, or heating iron, for toasting the bread; and a few dishes, some of wood and some of stone ware. Two or three chairs or stools, and a press or cupboard for holding the crockery ware, and the bread, the cheese, the butter, and, at times, the whisky bottle. A tea equipage, on a small scale, has also of late become an indispensable article of cottage fur-

niture; for tea-drinking has now found its way every where. It seems to be gentle species of ebriety, which sets the imagination and the tongue at work, without incurring the imputation of drunkenness, or breaking any one precept, human or divine. Wherever it is once introduced, it keeps its ground as certainly as snuff or tobacco, and becomes nearly as inveterate a habit; but happily it serves as an article of food, at the same time that it is a luxurious gratification. The value of the furniture of a cottage may be estimated at from ten to twenty pounds.

The cottagers are moderate and plain in their food; but they are not so in their clothing. Hardly any thing but English manufacture will serve them. At kirk and at market, it is difficult to distinguish the man from the master, and still more so, the maid-servant from her mistress. Either the one or the other have seldom less than five pounds worth of clothes, and often twice that value, on their back at once.

The village of Laurence-kirk was founded by the late Lord Gardenstone, about 1760, and in 1781 he procured a charter by which it was declared a burgh of barony. There is an excellent inn here, with a library and museum for the use of the traveller. There is a manufactory of sycamore snuff-boxes; and the lands in the neighbourhood have been raised in value from ten shillings to three and four pounds per acre.

3. *Occupation.*

Arable farms of various sizes: many small; some 400 or 500 acres. Hill pastures let in tracts by the thousand acres. One farm occupies 30,000 acres. Leases formerly let on periods of two, three, and four times nineteen years, with sometimes a life-rent after; of late the term seldom exceeds nineteen or twenty-one years, unless when great improvements are expected to be made by the tenants. The arable land is cultivated under judicious rotations, in which either turnips or fallow enters, according as the soil is light or clayey. The mountains are devoted to the breeding of cattle. There are few or no public gardens or orchards, but great extent of young plantations, and some patches of native birch and hazel coppice. The cattle are a small, hardy, kindly feeding breed. Horses of the Clydesdale variety are reared by many farmers, and most kinds of improved stock have been tried. Bees are generally kept. There is a good deal of sea-fishing, and some valuable salmon fisheries; but excepting ropes, nets, canvass, &c. there are no manufactures of any consequence.

7852. ABERDEENSHIRE. 1,270,744 acres, one sixteenth of Scotland, and one fiftieth of the area of Great Britain. The surface for the greater part not very irregular, but hilly and mountainous in the district adjoining Inverness-shire: the soil in general clayey and moory; the climate milder in winter than that of Middlesex, owing to the circumambient sea, but the summers short and cold; the agriculture assiduously pursued, and the products chiefly corn and cattle; — great part planted with trees. The report of the county is more than usually intelligent, and contains two preliminary sections, on the lessons which other counties may derive from Aberdeenshire, and on the improvements which this county may derive from others. Aberdeen exhibits a successful example of spade and plough culture combined, in the small holdings of tradesmen, mechanics, cow-keepers, and gardeners; and may profit from other counties southwards, by greater attention to collecting manure, employing women and children in the lighter operations of husbandry, and limiting tenants to a certain number of subtenants. The celebrated Dr. James Anderson farmed extensively in this county at Mourie, now the property of his eldest son, Alexander Anderson Seaton, a distinguished horticulturist. (*Keith's General View, 1811. Edin. Gaz. 1827.*)

1. *Geographical State and Circumstances.*

No metals or coal, and very little limestone, but abundance of excellent granite, which is used for every sort of building at home, and exported to London in great quantities. Besides the durability, there is one other excellence attending the use of this stone; the expense of carving it has simplified the style of architecture. The Braemar mountains abound with cairngorms and other precious stones; some topazes and beryls have been found, the latter of great value.

2. *Property.*

Much divided; only two or three large estates. Lord Aberdeen's the most valuable, consists of 50,000 arable acres, and 25,000 waste.

3. *Buildings.*

A number of ruined castles and religious buildings, and a few handsome modern houses. An ample descriptive list of gentlemen's seats, which are very numerous. Farm-houses, formerly wretched structures of clay, turf, and thatch, are now greatly improved; cottages improving. "Decent farm-houses" first began to be thought of about 1760. In 1794, Dr. Anderson observes in his report of the county on which the present one is founded, that they are "for the most part very poor. This is," he adds, "highly impolitic. Nothing contributes more to the content and convenience of a farmer, than good and well disposed buildings. It elevates his mind; gives him spirit to pursue his operations with alacrity; and contributes, in many instances, to augment his profits. I never yet saw a thriving tenant who had not good houses. But on no account should he be induced to expend that stock upon building houses, which should be employed in extending his own proper business. It ought always to be done by the landlord; and, in general, a good set of houses upon a farm, will bring him much greater additional rent than the interest of

the money expended upon them. Nothing will prove such an allurement as good buildings, and long leases on equitable terms." Since 1794, when Dr. Anderson wrote the above paragraph, we have got farmers from Berwickshire, Angus, Mearns, and other southern districts, who have taken farms in Aberdeenshire, and many of whom have shown excellent examples in agriculture, as well as improved their own capital; and the native farmers of the county, in consequence of their example, both in requiring good houses, and in raising good crops, are now in a much more flourishing situation.

4. *Occupation.*

The greatest diversity in the size of farms; from six acres to thousands; scarcely a mechanic, journeyman, or master, who has not a farm of one acre or two, or a garden; besides the produce, they find the labour highly conducive to health, by counteracting the effect of in-door confinement, and prolonged unfavourable bodily postures, or contaminating respiration.

5. *Implements.*

Turnips formerly sown from a small tin box, nine inches long, and one inch square, with two or three holes at one end, through which the operator shook out the seeds; thinned by a part of the blade of an old scythe fastened to a bit of iron like a common hoe; the advantages of the latter are its sharpness, but it is easily broken. A child's cradle rocked by water.

6. *Enclosures*

Stone fences, or ditches and earthen banks, the common fences; these free the land from loose stones, which abound every where, or serves to drain it.

7. *Arable Land.*

Potatoes, as well as various other improvements, first introduced to field culture after the calamitous year 1782; not liked by farmers so well as the turnip. The reporter tried various experiments in distilling from potatoes, which are recorded in

the *Farmer's Magazine*. Yellow turnips very much sown, and generally preferred by the cow-keepers. Rûta bâga in great repute; but requires to be earlier sown than the yellow, and, consequently, does not admit of so thoroughly cleaning the ground. Carrot, beet, scorzonera, and other roots, fermented and distilled by the reporter, the best spirit and greatest quantity from carrot. White beet grown, but found to yield less produce than turnip, carrot, or cabbage.

8. Gardens and Orchards.

The county of Aberdeen is distinguished beyond any other county in the island, for the preparatory branch of all good gardening, viz. *trenching the soil to a proper depth*. We have a numerous class of gardeners in the vicinity of Aberdeen, who cultivate the lands in the neighbourhood of that city, and whose practice deserves to be generally known, and generally imitated. They, in fact, are kitchen gardeners, seedsman, and nurserymen. They raise all sorts of roots for the inhabitants of the cities of New and Old Aberdeen, various seeds for the use of the country at large, and nurseries so extensive, and so carefully managed, that, besides serving the landed proprietors in the county, and the owners of villas near the towns, they export considerable numbers of plants to England.

A few good private orchards; the largest that of Ferguson of Pitfour, of ten acres. The site of it, nearly 600 years ago, contained the Abbey of Deer, founded in 1218, and the garden belonging to the monastery. It is a striking proof of the luxury of the Romish clergy, and of their uncommon skill in the raising of fruit-trees, that when Ferguson was laying out his new orchard, he found in the abbey garden, first, rich soil above three feet deep; secondly, a well-paved causeway of granite; thirdly, a bed of pure sand, one foot deep; fourthly, another causeway of granite; and below the whole, a considerable depth of rich mould. No greater precaution could have been taken to hinder the roots of the fruit-trees from being injured, by piercing into a cold or wet subsoil.

9. Woods and Plantations.

In the higher division of Mar, occupy nearly 100 square miles, in some places very thickly planted, and in others raised by nature, at very different distances between the trees. Nearly one third has been both enclosed and planted; one third has been raised by nature, without either enclosing or planting the ground; and the remainder has been surrounded by fences for keeping out the cattle, and then been stocked with wood, raised from seed, either blown by the wind, or carried by the rooks, who, by some instinctive impulse, carry the cones of the Scotch pine in their bills, to provide habitations for their offspring, at a remote period; when the seeds contained in these cones become trees, in which they may build their nests. This supposed instinct in the rooks is more probably called forth with a view to a firm surface to break the cones on; and on such an open surface, also, the cones are sooner opened by the heat of the sun, which enables the rooks to find the seeds without labour. In these higher districts, wood grows so easily, that the proprietor need only enclose an extent of hilly ground, and thus shut out the cattle. The wind and the crows will, in time, supply him with seeds. But when these natural woods grow very irregularly, it is found prudent to assist nature, by sowing, or occasionally scratching into the soil, a number of seeds of the trees which are wished to be reared in the vacant spaces. The greater proportion of these woods consists of Scotch pine; it grows slowly at first, but is very valuable. Where the soil is most barren, and the trees grow very slowly, the wood of the Scotch pine is of the best quality. A remarkable tree, at Invercauld, was cut down about forty years ago;

7853. NAIRNSHIRE and MORAYSHIRE, forming together 512,000 acres of mountainous surface, and some narrow arable vales, are included in one survey. The climate along the Moray Frith has always been noted for its mildness, which is partly owing to its localities, and partly to the general prevalence of a dry sandy soil. On the mountains the climate is more severe. Lead, iron, lime, marl, freestone, slate, &c. are found, but the first two are not worked at all, and of the others, only the freestone, to any extent. (*Leslie's General View*, 1810.)

1. Property.

In very large estates; as, for example, those of the Duke of Gordon, and Earls of Findlater, Moray, Fife, and Lord Cawdor.

2. Buildings.

Considerable as has been the alterations in the houses of proprietors, it is nothing to that which has taken place in those of farmers. Prior to the year 1760, in the dwellings of tenants there were neither floors, ceilings, nor chimneys. In a few of them, the low wall was rudely raised of stone, and clay mortar, and had a small glass window; in one only of the apartments was any plaster, and it was raked over the walls in the most artless manner; a loft, on which the roof rested without any side wall, distinguished a very few of the most respectable habitations. There was in general but one fire (which served all domestic occasions) in the apartment, where the servants and master, with his wife and maiden daughters, lived and fed together. In the higher parts of the district, matters were much worse. Now, upon every farm of any consideration, the buildings are substantial, commodious, and neat.

3. Occupation.

As in Kincardineshire; but the arable lands being generally light, the turnip husbandry is more prevalent. It is a singular fact, that in an island in a lake, Loughnadurb, in this county, the turnip is found more plentifully in a wild state than any where else in Britain. This island contains a fortress, and the reporter conjectures that turnips being introduced at an early period from the Continent, the small plot of ground within the walls could not be occupied by any crop more convenient for its temporary inhabitants than that of turnips and coleworts. It may be conjectured that the last crop, probably sown from 300 to 400 years ago, had never been gathered. Until of late the turnips in this island sprung up annually in a thick bed,

7854. The shires of ROSS, NAIRN, and CROMARTY are three adjoining mountainous districts, containing 2,204,800 acres. The soil is in general light, sandy, or peaty. Minerals of various kinds have been found, but only building-stones and lime are worked. (*Mackenzie's General View*, 1810.)

1. Property.

Is in few hands, and till of late underwent but few changes. There are no sources of information from which a precise

and the number of concentric circles near its root, viz. 229, showed it to have grown and increased in size for 229 years, besides the time that it continued stationary. Its wood was declared, by all who saw it, to be much superior in quality to any that had ever been imported from the north of Europe. There are thousands of pine trees in Braemar, some of which are nearly six feet in diameter, which are superior, in point of quality, to any wood of that denomination that was ever imported into any place in Great Britain.

10. Improvements.

Trenching has been already mentioned: within three miles of Aberdeen, above 3000 acres trenched; some acres paid 50*l.* per acre for granite bowlders for exportation. Practice of trenching very general throughout the county.

Irrigation adopted on poor iron-stone clay, not worth two shillings per acre, but raised in value to two pounds. The operator brought from Gloucester, by Ferguson of Pitfour.

11. Live Stock.

More cattle bred than in any other county. Scotch cattle first improved by crossing some English cows sent down by Henry VII. to his eldest daughter, queen of James IV. The produce was known as the Falkland breed. Williamson's three brothers sell annually about 8000 head of cattle of various breeds, in the south-country markets. They decidedly prefer the true native, unmixed, and raised by good keeping, to the mixture of the Falkland, or Fifeshire breed, with that of this county; and consider both these to be much superior to the English, or to any foreign breeds. They justly remark, that the food, or keep, should be always above the breed, and not the breed above the keep. They consider the small highland cattle, which are generally bought by inferior dealers, as too restless and impatient for feeding well. They prefer the native low country breed to the larger ones, as they are most easily maintained, more hardy in work, have flesh of the finest grain, and pay better in proportion to the goodness of their keep. Every succeeding generation, for the last thirty years, has increased in size, and that by good keeping; the native breed is double its former size (*i. e.* weighs at least double its former weight) since the introduction of the turnip husbandry. They are also decidedly of opinion, that wherever a landed proprietor breeds more than one year for family use, the stot should not be tied up, but allowed to feed loose, in order to get gentle exercise along with his food; that the second year he may be put to high feeding, and be tied up, and may be continued with this high feeding as long as he seems to thrive; but that he ought to be killed whenever he loaths his food, or appears to be sickly, or not thriving.

The sheep few, and of a mixed breed. Horses are native ponies, or purchased from Clydesdale. Poultry very common; great demand for eggs, both for the Aberdeen and London markets. Red deer in great numbers in Braemar, and roes on the hills of Cromar.

12. Manufactures.

County long celebrated for its woollen manufactures. About 1660, Garden of Gilcomeston, a wealthy sheep farmer and manufacturer, had a daughter, who married Lieutenant Cadogan of Cromwell's army, who afterwards was made a peer, and from whom sprang the Duke of Richmond, Earl of Leicester, Lords Cadogan, Verney, Holland, C. J. Fox, and the heads of other eminent English families.

Woollen, linen, and cotton, now extensively manufactured. Knitting of stockings and spinning lint formerly common, but little attended to since the introduction of machinery.

without culture. The root, in some favoured situations, it is said, had been found of one pound weight; but they resemble in general the wild kind, having a long root like a small radish, of acid juice, and a rough pointed leaf. Some plants of red cabbage were also distinguished among them. Both were used as pot-herbs at the tables of the country people, on which account they were sometimes raised in their gardens. When they began to run to seed on this island, young cattle were ferried in to feed on them. The Rev. Francis Forbes, minister of Grange, has seen rentals of the family of Craigyvar, from which it appears that turnips were paid as an article of rent in the end of the seventeenth century. The quantity (about 200 bushels) shows that they must have been applied as food for cattle. By the famine which unfortunately took place at that period, however, every agricultural branch of industry was so deranged, that this important object, instead of being extended, was, even there, wholly abandoned.

The cultivation of turnips, as a food for cattle, was first introduced into this district, from the county of Norfolk, by the late Earl of Findlater, about the year 1760.

When the artificial grasses and herbage plants were introduced, only regular gardeners were employed to sow them; now common country operatives perform the operation. Few orchards; apples imported from England; a few natural woods, and extensive artificial plantations. In general it may be observed, that in this, as in the other counties of the north, every description of improvement has been tried, and such as are found to answer, as draining, burning, irrigation, planting, road-making, &c. carried to a great extent. All the improved implements have been tried, and the reporter even proposes an addition to them, in the form of circular harrows; the circle of cast iron, and the tines of wrought iron, screwed in or fastened with nuts and screws. (*See fig. 7787.*) There is a good deal of fishing carried on along the coast, and in the Moray Frith.

knowledge of the state of agriculture in these and other northern counties, previously to the rebellion in the year 1745, can be derived; but from what it has been since that time, until about

1760, it may safely be concluded, that agricultural knowledge was neither sought for nor desired. The mode of management which has been practised in these counties, and in other parts of the highlands, and which has been handed down from father to son for many generations, is still to be found in the midst of the most improved districts. We still see the arable land divided into small crofts, and many of the hills occupied as commons. On the west coast particularly, the ground is seen covered with heaps of stones, and large quantities are collected on the divisions between the fields; so that a considerable portion of the land, capable of cultivation, is thus rendered useless, by the indulgence of the most unpardonable sloth. The management of the native farmers is most destructive. The soil of one field is dug away to be laid upon another; and crop succeeds crop, until the land refuses to yield any thing. It is then allowed to rest for a season, and the weeds get time to multiply. Such, we must suppose, was the system of farming before the rebellion; we cannot imagine it to have been worse.

2. Buildings.

The old highland tenantry are universally ill accommodated. They live in the midst of filth and smoke; that is their choice. But wherever farms have been laid out on a proper scale, and are occupied by substantial and well-educated men, we find the farm-houses and offices handsome and commodious. Every proprietor who wishes to see his estate rapidly improved, will erect suitable buildings, at his own expense, before he invites a good tenant to settle upon it. The interest of his money will be always cheerfully paid; and if the landlord agrees that the repairs shall be made at the mutual expense of himself and his tenant, the latter will thrive, and the former will never have to demand his rent twice. The present race of highland tenants will yet find themselves much happier, and more com-

7855. CAITHNESS. 395,680 acres, three eighths of which is deep, mossy, and flat moors, covered with heath; three eighths mountain, moor, and some hilly pasture; and the remainder in cultivatable land, lakes, &c. There is very little wood, either natural or artificial; but excellent lime and freestone. On the whole it is one of the coldest, wettest, and most dreary counties of Scotland; and is in no way remarkable, unless for being the scene of Sir John Sinclair's practical attempts at improvement. Of these the chief seems to have been the enlargement of the town of Thurso; of which, and of various other schemes, ample information is given in the report, and in a number of appendices to it, by Sir John himself. (*Henderson's General View*, 1812.)

1. Property.

Is in a few hands, and the Irish practice of tacksmen tenants exists, and has existed from time immemorial in the county. These tacksmen, as they are called, generally occupy a part of the land themselves, and sub-let the remainder to the small farmers, for a certain money-rent, payments in grain, customs, and service (the latter in many cases unlimited); so as to have, upon the whole, a surplus rent for the trouble and risk of recovering their rack-rents from the sub-tenants.

A few young men from the south of Scotland have been brought to this county, to superintend the proprietors' farms or domains, for the purpose of introducing the practice of modern husbandry. These, from time to time, have taken farms in this county; but whether their agricultural skill was superficial, or that they did not understand the mode of farming best adapted to this cold and moist climate, they have neither increased the crops, nor improved the landlords' farms placed under their direction; nor has their industry or skill produced better crops on their own farms than what is raised by a similar class of the county farmers, who have never been out of it.

7856. SUTHERLAND. 1,872,000 acres, chiefly of mountain and moor; and a climate about a fortnight later than that of Edinburgh. The greater part of the county is the property of the Marquess of Stafford, whose astonishing, masterly, and successful improvements have been amply detailed in Loch's work, from which we derived so much information for Staffordshire and Shropshire, and to which we again recur. (*Henderson's General View*, &c. *Loch's Improvements of the Marquess of Stafford*, &c. 1819.)

The estates of Sutherland have only lately undergone that change which began to operate in England as far back as the reign of Henry VII. This change had for its object the creation of a middle class, by the depression of the barons and the raising up of the next class of the community. This object was gradually and successfully accomplished in England by the time of Queen Elizabeth, and in the south of Scotland soon after the union of the two kingdoms: but the highlands, or most northerly counties, underwent no change till the discomfiture of the pretender, and the abolition of the heritable jurisdictions then existing in the north, in 1747. This invaluable act having brought the highland chieftains within the pale of the law, and placed them on the same footing as the other gentlemen of the land, they began rapidly to acquire the same tastes, to be occupied with the same pursuits, to feel the same desires, and to have the same wants as their brethren in the south. In order, however, to indulge these propensities, and to be able to appear in the capital with due effect, it was necessary that they should convert their estates to that mode of occupation most suited to their circumstances, and from which they could derive the greatest income. Luckily in this, as in every other instance in political economy, the interest of the individual and the prosperity of the state went hand in hand. And the demand for the raw material of wool by the English manufacturers, enabled the highland proprietor to let his lands for quadruple the amount they ever before produced to him. These arrangements continued to be carried into effect from time to time, in the southern and central highlands, up to about the commencement of the French revolution war; not always, however, without serious resistance on the part of the people.

The northern highlands still remained to undergo that change which the rest of the island had already adopted. In this district it naturally began to be followed in the counties situated nearest to those into which it had already been introduced. In Ross-shire, accordingly, it was undertaken on a great scale, in 1792. The dissatisfaction produced was so great, that the most serious affairs took place, and the military had to act, and blood was shed before quiet was restored. Between that time and 1815, the greater portion of the county of Sutherland, belonging to Lord and Lady Stafford, was arranged according to those plans so universally adopted. This ancient condition of society prevailed longer on the estate of Sutherland than in any other part of the island, on account of its difficult access

portable, in the capacity of servants to substantial tenants, than in their present situation. The dwellings of cottagers are not worse than those of the native farmers. The same roof covers men, women, children, cattle, dogs, pigs, poultry, &c. It must afford great pleasure to every lover of his country to observe the neat cottages that are erecting in every part of the country; but it will be long ere the people will learn the comforts of cleanliness and the use of chimneys. In many places where these have been constructed, the people do not use them, but prefer breaking a hole in the roof of the house, and lighting their fire on the floor. Smoke, they say, keeps them warm.

The occupation and management of land is the same as in other mountain districts. Some grain, chiefly oats, is raised in the low grounds, with root and herbage crops, and the pastures are devoted to the breeding of cattle and sheep. Every improvement is tried by the principal proprietors; and enlightened farmers from the south of Scotland, accustomed to breeding, induced to settle on their estates, by long leases and moderate rents. From these the smaller native farmers take an example sooner than they would from the operations of proprietors, which they are apt to consider as at least of dubious value. When a rent-paying farmer, however, adopts plans new to them, the case is very different. Of woods, in this district, there are very few; but many plantations have been lately made round gentlemen's seats, especially Lord Seaforth's. In 1821, Colin Mackenzie, Esq. of Kilcoy, planted 200 acres with 5000 trees; the sorts, oak, Scotch pine, larch, alder, birch, ash, and some ornamental trees. (*Highl. Soc. Trans.* vol. vi. p. 258.)

The great post roads in this district have been made, in part by government, and in part by the proprietors. There is a cotton manufactory at Cromarty, and the reporter suggests the idea of manufacturing tar from the trunks of fir trees, found bedded in all the mosses of this and other highland districts.

The principal farmers in the county under review are intelligent gentlemen, who have been for some time in the army, or followed other avocations, either in the southern counties of Scotland or in England, who work their farms upon the principles of modern agriculture, as practised in the southern counties of Scotland, as far as the state of the county, as to climate, roads, the means of improvement, markets, &c. will admit, but at a much greater expense than is done to the southward, and, of course, much less benefit to themselves. In general they have other sources of income, which enable them to live in a social and comfortable state in society; they are better educated than farmers paying a similar rent in England; agricultural knowledge, therefore, is soon circulated amongst them.

The smaller class of farmers, with few exceptions, are industrious, sober, sagacious, and moral in their behaviour. They have, unfortunately, a turn for litigation, and expend more money than they ought to do in law, by which their circumstances are often injured.

across the Dornoch and other friths, and the total want of roads in the county till 1809. The estate of Sutherland (*fig.* 1151. *a, a, a*), including the barony of Assynt (*b, b, b*), and the late purchases made by the Marquess of Stafford, up to 1819, was computed to contain more than 800,000 acres. The estate of Lord Reay (*c*) is more than half that extent; it was purchased some time ago by the Marquess of Stafford, and annexed to his own estate. The residue of the county belongs to different smaller proprietors (*d* to *n*).

In 1809 was begun a line of road, conducted according to the best principles of the art, and made in the most perfect manner, from the town of Inverness by Beaully and Dingwall, to the boundaries of the county of Sutherland; two excellent stone bridges, consisting of five arches each, having been built across the Beaully and Conon rivers. The two principal obstructions these roads had to contend with and to surmount were those which were occasioned by the two friths of Dornoch (*fig.* 1151. 1.) and of Loch Fleet (2). The former, especially, presented obstacles of considerable moment, arising out of the width of the channel, and the want of a proper foundation on which to construct a bridge. If the same plan had been followed in this instance, which has been adopted on the two southern ferries, namely, of ascending to the point at which the frith terminates and becomes a river, it would have carried the road so much into the interior, as to counterbalance those advantages which are at all times obtained by the substitution of a bridge in the place of the most perfect ferry which can be established. To avoid either of these inconveniences, a very careful survey of the whole frith was made; and the engineer, Telford, determined to recommend the construction of an iron bridge of magnificent dimensions (See an engraved view in the *Ed. Encyc.*) at Bonar, a point where the frith narrows itself considerably, and above which it again expands, though not to its former dimensions. This structure consists of an extensive embankment, with two stone arches of fifty and sixty feet span, respectively; and one iron arch of 150 feet span. It cost 13,971*l.* From this point, the heritors of Sutherland have constructed a road (4, 4) to Tongue (*e*), the seat of Lord Reay, situated upon the Northern Ocean.

In many places, these roads are cut through the hardest rock; in others, they are obliged to be supported on bulwarks of solid masonry. Expensive drains to protect them from the mountain floods, and bridges over the innumerable streams that rush from the hills in every direction, are required. These

must be formed of the most durable materials, and the best workmanship, to resist the impetuosity of the torrents. Nothing will set this in so striking a point of view, as to state, that upon the projected road to Assynt, a distance of forty-six miles,

three bridges of three arches each, two bridges consisting of one arch of forty feet span, five of twenty feet span, three of twenty-four, six of eighteen, two of twelve, besides many others of inferior dimensions, would be required. On the Stafford

1131

NORTHERN OCEAN



estate excellent inns, often combining farmeries, have been built in a number of places at an enormous expense. As an example, we may refer to one (fig. 1132.) containing an outer kitchen and servants' stair (a), with a pantry (b), two best parlours, with movable partition for great occasions (c), principal entrance (d), a small parlour (e), small room (f), kitchen (g), back kitchen and servants' stair (h). Over are five bedrooms, and nine garrets for beds.

Thus, in the course of twelve years, has the county of Sutherland been intersected, in some of its most important districts, with roads, in point of execution superior to most roads in England. And owing to the equally praiseworthy exertions of the counties of Ross and Inverness, on the one hand, and of Caithness on the other, the same perfect means of communication now exists, from the burgh of Inverness to the town of Thurso upon the North Sea.

Few districts of Scotland possess so small a proportion of land fit for cultivation, compared with its extent, as Sutherland; and previously to the year 1811 but even a small portion of that was brought into cultivation. Each shore is fringed (if the expression may be used) with a narrow border of arable land, which, on the south-east coast, extends from a few hundred yards to about one mile in breadth: the interior consists entirely of mountains.

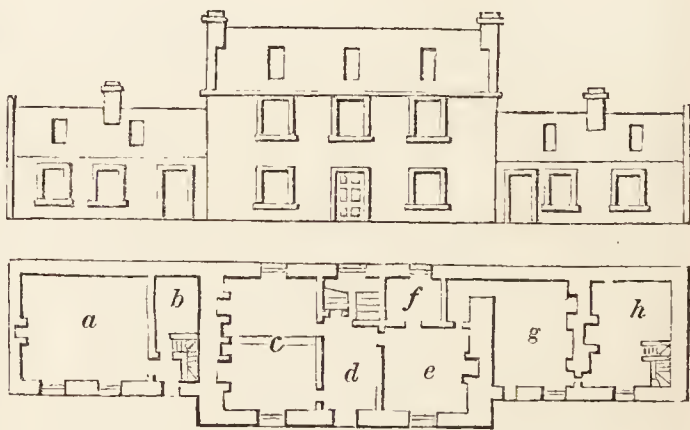
The lands were let to tacksmen, as in Ireland, till in latter times, when a certain district was let to the whole body of tenants resident in each "town or township," who bound themselves, conjointly and severally, for the payment of the whole rent. This land was held, as expressed in Scotland, "run rig," or like common field land in England.

The effect of this arrangement was to scatter thickly a hardy, but not an industrious race of people up the glens, and over the sides of the various mountains; who, taking advantage of every spot which could be cultivated, and which could with any chance of success be applied to raising a precarious crop of inferior oats, of which they baked their cakes, and of bere, from which they distilled their whiskey, added but little to the industry, and contributed nothing to the wealth, of the empire. Impatient of regular and constant work, all the heavy labour was abandoned to the women, who were employed, occasionally, even in dragging the harrow to cover in the seed.

To build their hut, or get in their peats for fuel, or to perform any other occasional labour of the kind, the men were ever ready to assist; but the great proportion of their time, when not in the pursuit of game, or of illegal distillation, was spent in indolence and sloth. Their huts were of the most miserable description. They were built of turf, dug from the most valuable portions of the mountain side. Their roof consisted of the same material, which was supported upon a rude

wooden frame, constructed of crooked timber, taken from the natural woods belonging to the proprietor, and of moss-fir dug from the peat bogs. The situation they selected was uniformly on the edge of the cultivated land, and of the mountain pastures. They were placed lengthways, and sloping with the declination of the hill. This position was chosen, in order that all the filth might flow from the habitation without further

1132



exertion upon the part of the owner. Under the same roof, and entering at the same door, were kept all the domestic animals belonging to the establishment. The upper portion of the hut was appropriated to the use of the family. In the centre of this upper division was placed the fire, the smoke from which was made to circulate throughout the whole hut, for the purpose of conveying heat into its farthest extremities. The effect being to cover every thing with a black glossy soot, and to produce the most evident injury to the appearance and eyesight of those most exposed to its influence. The floor was the bare earth, except near the fire-place, where it was rudely paved with rough stones. It was never levelled with much care, and it soon wore into every sort of inequality, according to the hardness of the respective soils of which it was composed. Every hollow formed a receptacle for whatever fluid happened to fall near it, where it remained until absorbed by the earth. It was impossible that it should ever be swept; and when the accumulation of filth rendered the place uninhabitable, another hut was erected in the vicinity of the old one. The old

rafters were used in the construction of the new cottage, and that which was abandoned, formed a valuable collection of manure for the next crop.

The introduction of the potato, in the first instance, proved no blessing to Sutherland, but only increased this state of wretchedness, inasmuch as its cultivation required less labour.

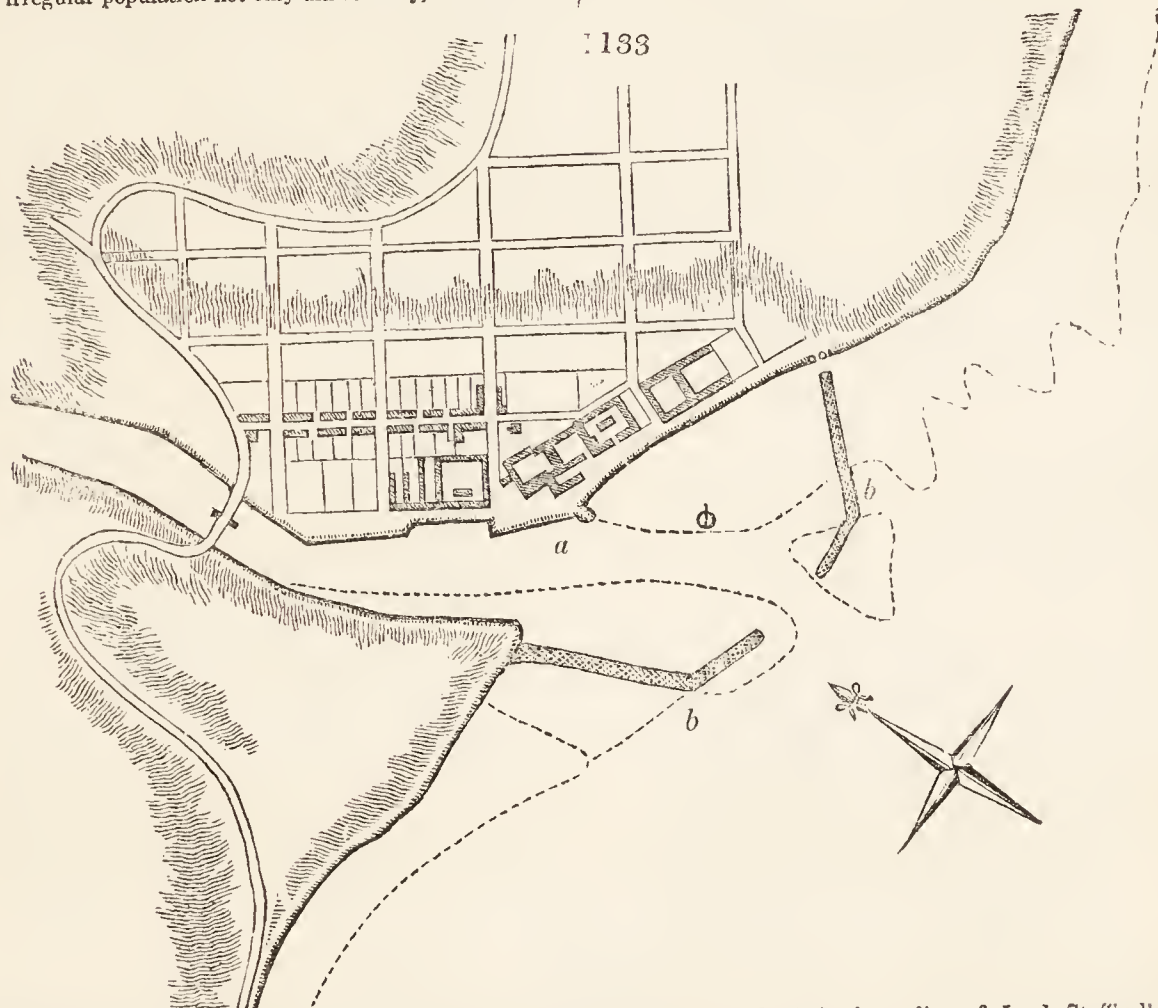
So long as this system just described remained in full force, no attempt could be made to improve or meliorate the situation of these poor people. To better their condition, however; to raise them from such a state of continual poverty and occasional want; to supply them with the means, and to create in them the habits of industry, was, and is the bounden duty of the owners of every such property. And it was not less their duty to do so, because the same arrangement which was calculated to produce this salutary effect, was at the same time the best suited to increase the value of their property, and to add to the general wealth of the community.

The fundamental principle of agricultural improvement in this case was derived from no speculative reasoning, but from what has actually taken place in a different but similarly circumstanced part of the kingdom.

It is well known that the borders of the two kingdoms were inhabited by a numerous population, who, in their pursuits, manners, and general structure of society, bore a considerable resemblance to that which existed in the highlands of Scotland. When the union of the crowns, and those subsequent transactions which arose out of that event, rendered the maintenance of that irregular population not only unnecessary, but a burden

to the proprietor to whom the land belonged, the people were removed, and the mountains were covered with sheep. So that it had been for a length of time proved by the experience of the stock farmers of those mountain tracts which comprise the northern districts of England, and the southern parts of Scotland, that such situations were peculiarly suited for the maintenance of this species of stock. Taking this example as their guide, experience had still further proved, that the central and western highlands of Scotland were equally well calculated for the same end. Reasoning from this success, and observing that the climate of Sutherland, owing to its vicinity to the ocean, and to its being considerably intersected by arms of the sea, and much more moderate than this latter district, it was fairly concluded that this county was even better fitted for this system of management than the heights of Perthshire and Inverness-shire. The inferior elevation of its mountains contributed still further to this effect, and held out every encouragement to adopt the same course which had been pursued with such success in both parts of the kingdom.

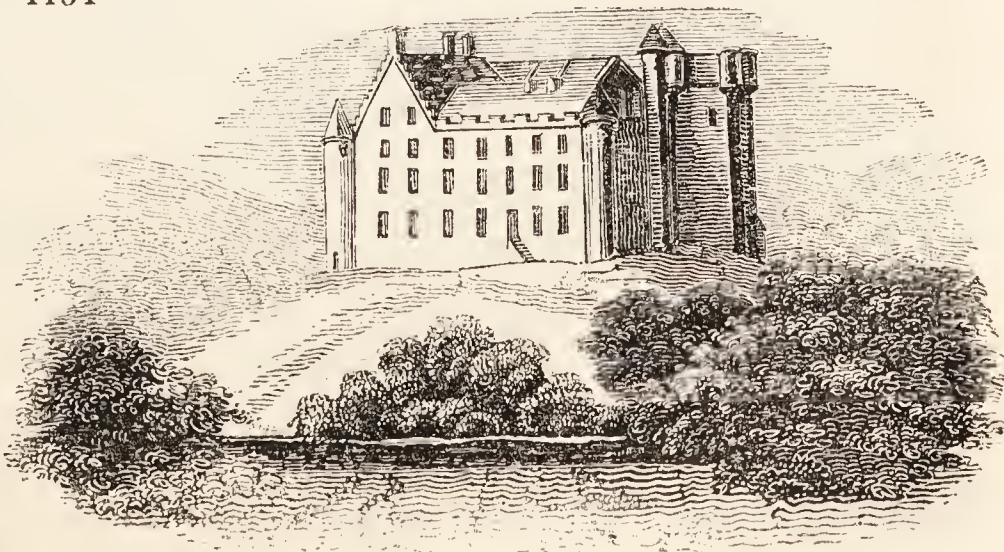
The propriety of converting the mountainous parts of the county into sheep-walks was in this way rendered evident, provided the people could be at the same time settled in situations, where, by the exercise of their honest industry, they could obtain a decent livelihood, and add to the general mass of national wealth, and where they should not be exposed to the recurrence of those privations, which so frequently and so terribly afflicted them, when situated among the mountains.



The principle of providing for the lower class of tenants by the establishment of fisheries was thus derived:— It had long been known, that the coast of Sutherland abounded with many different kinds of fish, not only sufficient for the consumption of the county, but affording also a supply, to any extent, for more distant markets, or for exportation when cured and salted. Besides the regular and continual supply of white fish, with which the shores thus abound, the coast of Sutherland is annually visited by one of those vast shoals of herrings which frequent the coast of Scotland. It seemed as if it had been pointed out by nature, that the system for this remote district, in order that it might bear its suitable importance in contributing its share to the general stock of the county, was, to convert the mountainous districts into sheepwalks, and to remove the inhabitants to the coast, or to the valleys near the sea. Several seaports were improved by the construction of piers (fig. 1133, a) and breakwaters (b); and the plan of a town being formed, the inn, church, post-office, market-place, and other public buildings, were erected by Lord Sutherland, and the most liberal encouragement given by loans of money, grants of land at little or no feu duty, &c. to fishers, manufacturers, tradesmen, &c., both on a large and small scale, to come and

settle there. Such is the policy of Lord Stafford's operations, in which he has expended, and continues to expend, independently of the cost of improvements on the mansion (fig. 1154.) and park of Dunrobin, immense sums. Happily the success has equalled the most sanguine expectations; but for the very interesting details of execution, our limits oblige us to refer to the work of Loch, which, as already observed (7795.), we consider of very singular agricultural interest.

1134



to come and

7857. **INVERNESS-SHIRE.** Upwards of 7,000,000 of by far the most mountainous region in Scotland. It reaches from sea to sea on the main land, and comprehends many islands, which are scattered far and wide. The hills and moors were formerly covered with fir woods, the remains of which are dug up in all the moors in abundance. The climate is rainy, mild on the west coast, but less so on the east. The soil of the vales is loamy or gravelly. The principal economical minerals are granite, lime stone, and slate; but lead, iron, marble, &c. have been found in different places. The county is remarkable for its native fir woods, and for that stupendous national work, the Caledonian Canal. Improvements were first commenced about Inverness by Cromwell's soldiers. (*Robertson's General View*, 1810.)

1. *Property.*

In few hands; largest, Lord Macdonald, of the Isle of Skye, the only nobleman who resides in the county. The mountain farms are large, and, as in similar cases, reckon by miles, or by the number of sheep they are supposed to carry.

2. *Gardens and Orchards.*

To be found in a few places; and some old pear trees, planted by the monks, are still in a bearing state at Beauly, and one or two other places. There is an excellent fruit and forest tree nursery at Inverness.

3. *Woods and Plantations.*

The Scotch pine, for the most part, took possession of the south side of the valley, and made choice of a northern exposure; the hirsch, the hazel, and the oak, occupied the warmest side of every district; while the alder and a few ashes ran along the streams. Not only the continental parts had this natural mantle, but the islands of this country appear, from the fragments of trees found in the mosses, to have been at some remote period, mostly, if not wholly, under forests. The only remains of growing wood at present in the islands are at Portree and Slate in Skye, and a little in the island of Raasa.

Trees were burned or felled to make room for men, by enlarging the pasturage of cattle, and affording fresh surface for corn. At present the Scotch pine covers more surface in this county, than all the other kinds of trees taken together; and the natural pine-woods of Inverness-shire exceed the quantity of this wood growing naturally in all the rest of Britain. In Strathspey alone, it is reported, upon authority which cannot be called into question, that fifteen thousand acres of ground are covered with natural firs. On the south-side of Locharkilg, of Glengarry, of Glenmoriston, Strathglas, Glenstrafaras, and at the head of Lochsheil, as mentioned above, the bounds of country under this wood are reckoned by miles, not by acres. The oak woods of this county are not so large, nor so well taken care of, as they are in Perthshire.

There are extensive birch woods, the timber of which is used for fencing and the coarser articles of husbandry, and the bark for tanning.

4. *Live Stock.*

Cattle are of the Skye or Kyloe breed, usually, however, known as the highland breed, and already described. (6796.) The cows yield only half the quantity of milk of the breeds of the low counties; generally from two to two gallons and a half; but it is rich, and productive of butter of excellent flavour. The diseases of highland cattle are few. The manner of disposing of cattle is as follows: When the drovers, from the south and interior of Scotland, make their appearance in the highlands, which always happens during the latter end of April, or the beginning of May, they give intimation at the churches, that upon a particular day, and in a central place of the district, they are ready to purchase cattle from any who offer them for sale. The drovers are of two descriptions: either those who buy by commission for persons of capital, who, being diffident of their own skill, or averse from fatigue, choose to remain at home; or those who purchase cattle on their own account. Much address is used on both sides, to feel the pulse of the market at these parochial meetings, before the price of the season is mutually settled; and it may happen, that many such small trysts or meetings take place in different parts of the highlands, before the price be finally determined. The anxiety on both sides is sometimes so great, that the cattle are given away upon a conditional contract, that if the price rises within

a limited time, the seller will receive so much more; but if the lean cattle fall in value, the drover will get a reduction.

Sheep are extensively reared, and generally of the Linton or Lammermuir black-faced sort. The Cheviots are also very prevalent.

Horses either the native pony or improved breeds from the low countries farther south.

Roos are frequent in a wild state in all the woody and warm glens.

5. *Political Economy.*

Roads and bridges have been going forward at the expense of Government ever since 1745, and earlier; and the Caledonian Canal is well known for its magnitude and the excellence of its execution. There are various fisheries on the lakes and coasts; but few manufactures.

As one of the *obstacles to improvement*, common to this and the other highland counties, and indeed to every county, the reporter mentions the stubbornness of the common people, in adhering obstinately to old and slovenly habits. As men rise in years, the reluctance to make any uncommon exertions, and particularly to introduce change into any thing, which relates to their personal accommodation, gradually grows upon them. Having been long accustomed to a certain course of employment, of gratification, of lodging, of dress, and of food, they resist strenuously the relinquishment of any of these habits; they move on in the current of human life mechanically, like a wheel, without any apparent alteration in their motion, unless it be accomplished by some external force; and, if left to themselves, they never change their course. This propensity to remain the same men, and to retain the same customs, is more unconquerable among the illiterate and ignorant, than among the learned or enlightened part of mankind. By means of society, of conversation, and of reading, the latter acquire an enlargement of the mind, to which the former are strangers; and if they be accustomed to reflect on what they hear and see, they are always more open to conviction. When that mulishness of the disposition, which, whether in the rich or the poor, the uncultivated or the refined, is still the child of ignorance, takes fast hold of the mind, it becomes so obstinate, that it can seldom or never be removed. Its universality would lead to the opinion, that it is an original principle in the human frame; its progressive influence, which increases with age, and the apology which such men urge in their own defence, that their fathers did such things before them, would imply that it is the effect of imitation.

The reporter, notwithstanding the above sentiments, goes on to state that he considers that the prosperity of the world would be more promoted by the steadiness and obstinacy of men living in error, than it would be by a spirit of fickleness, and a desire of change. It might easily be shown that the real meaning of such a sentiment is, that those who are already prosperous, that is, those who have already a sufficient share of the good things of life, will stand least chance of losing what they have, while things remain as they are. The prosperity of the world, if unfortunately happens, has hitherto been too frequently understood to mean the prosperity of those only who are already prosperous. This state of things is in the natural course of the progress of society from darkness to light: but it will pass away in its turn, and the time will come when the prosperity of a people will really mean what the words import. When this time arrives, what the reporter would probably call fickleness, and a desire of change, will be found to have had some share in bringing it to pass.

7858. **ARGYLESIRE.** 2,433,000 acres; the eleventh part of Scotland, and the thirtieth of Great Britain, and nearly the whole of the Scottish kingdom from A. D. 503 to the subjugation of the Picts in 843. The surface of the country is rough and mountainous: in the northern parts "Alps piled on Alps hide their heads in the clouds." The climate is moderately mild, very moist in the vales and on the coast, but cold and severe on the elevations. The soil of the vales is generally light; the minerals are copper, lead, iron, coal, strontian, freestone, granite, limestone, marble of several different colours, slates, &c., but the two first are not worked at present. There are numerous bays, inlets, and lakes, in some of which excellent fish is caught. The county is in no respects remarkable in an agricultural point of view; it furnishes immense quantities of cattle and sheep to the graziers and feeders of the south; and there are some oak coppices and artificial plantations. (*Smith's General View*, 1810. *Edin. Gaz.* 1827.)

1. *Property.*

In the hands of 156 owners. Farms of the smaller size reckoned by acres, the largest by miles. One, supposed to be the largest in Britain, is eighteen or twenty in length, by three or four miles in breadth; several contain from two to six square miles: object, as in Inverness-shire, the breeding of cattle chiefly, and next sheep.

2. *Improvements.*

Have been made by most of the proprietors: some plans of farmeries are given by the reporter. One is circular, and consists chiefly of cattle sheds; but the elevation is of that mongrel Gothic, which is displayed in most of the modern highland châteaux. The fin-share or Argyleshire plough (2618.) was invented in this county by the reporter.

3. *Woods and Plantations.*

There are about 50,000 acres of coppice, chiefly oak, birch, and hazel, which, being now valuable for the bark, and the poles to be used as spokes for wheels, is beginning to be en-

closed from the sheep by stone walls. The Duke of Argyle is the chief planter, and his larch plantations are of great extent, and contain an immense quantity of valuable timber. The oldest and largest of the trees at Inverary are supposed to have been planted by the Marquess of Argyle between the years 1650 and 1660. Those of the next largest size and age were raised from the seed by Archibald Duke of Argyle (called a tree-monger by Walpole), in 1746 or 1747. These consist chiefly of larches, New England pines, spruce and silver firs.

4. *Live Stock.*

Cattle, the west highland breed; the best in the districts of Argyle, Lorn, Ilay, Colonsay, and Mull.

Sheep, till lately, much neglected.

Horses, a hardy native breed, larger than the pony.

5. *Political Economy.*

Roads as in Inverness-shire. A canal from the coal works in Campbellton to the sea: few manufactures. An agricultural society at Kintyre.

7859. The **HEBRIDES**, including **BUTESHIRE**, consist of nearly 300 islands, eighty-six of which are inhabited, and contain 2,037,760 acres of rocky, hilly, and, in some islands, mountainous country, with a severe, unsteady, moist climate, and a soil generally light. Almost all the minerals are found with which the continental part of Scotland is furnished. Slate, lime, granite, marble, and freestone, are in great abundance; and coal has been found in various places, though it has not been successfully worked. Steatite, or soapstone, from which porcelain is manufactured; fullers' earth, and a great variety of other

economical minerals, besides rare and curious species, are found in different islands. (*Headrick's Survey*, 1796. *Macdonald's General View*, 1811. *Edin. Gaz.* 1827.)

1. *Property.*

In the hands of forty-nine proprietors; highest rental 18,000*l.* and acres 312,500. A great many tacksmen. Those of Ilay are said to "combine with the spirit and elegant hospitality indigenous to this country, the accuracy in dealing, the punctuality in paying, and all the useful qualifications of first-rate low country farmers. It must not be forgotten, in mentioning the order of tacksmen, that they are exceedingly useful, and often necessary, for maintaining good order and government in the country. Without their aid, the efforts of the clergy and officers of justice would be painful and unavailing: and therefore they ought not to be rashly banished, were they to be viewed in no other light than merely as subsidiary to the police and moral administration of the Isles.

2. *Buildings.*

Farm-houses throughout the Hebrides are either houses of tacksmen, of tenants, or subtenants. Tacksmen's houses, though still far behind those of considerable farmers in the principal counties of England and the lowlands of Scotland, are, however, in general, beginning to be tolerably decent and comfortable; and on all the large estates they have been very much improved within the last twenty-five years. Most of them are now built of stone and lime, and roofed with blue slates, two stories high, and furnished with kitchens and other accommodations. In many instances, indeed, the office-houses are still in a deplorable state, but even these are rapidly improving; and should this order of farmers exist for half a century longer, their houses will, probably, be as commodious, and their office-houses as judiciously planned, as those of the same description of men in any part of Great Britain.

The houses of the occupying tenants are, generally speaking, wretched hovels, and those of the subtenants nasty and miserable beyond description. Pennant describes them as habitations made of loose stones, without chimney or doors, excepting the faggot opposed to the wind at one or other of the apertures permitting the smoke to escape in order to prevent the pains of suffocation. Furniture corresponds: a pot-hook hangs from the middle of the roof, with a pot hanging over a grateless fire, filled with fare that may rather be called a permission to exist than a support of vigorous life: the inmates, as may be supposed, lean, withered, dusky, and smoke-dried.

It cannot be denied, that this picture is, in some degree, realised in a few of the Hebrides, even at the present day.

The cottages in the Hebrides are almost universally so miserable, both in plan and execution, that they deserve mention only as proofs, that a sensible and sagacious race of men may, by a combination of unfavourable circumstances, not only be gradually brought to endure privations, which, to their equals in other countries, would seem intolerable, but also, in the course of time, they may lose the power, and even the will, of surmounting them. Three fourths of the 40,000 cottagers of these isles live in hovels which would disgrace any Indian tribe; and many of them are found on islands of the first rank in point of population and extent. At least 7000 of the natives of Lewis (for instance) know nothing of a chimney, table, glass window, house flooring, or even hearth stone, by their own experience at home; and what we call their furniture is, as may be imagined, wretched and scanty beyond description, corresponding with their shabby exterior.

In the woods of the park at Bute were formerly fine specimens of Swiss cottages and other fancy wooden buildings. (*fig.* 1155.)

3. *Occupation.*

In estimating the size of Hebridean farms, the common plan is to attend to three leading objects: first, the number of live stock which the farms in question can maintain; secondly, the number of bolls of grain which can be sown, or of ploughs requisite for their tillage; and, thirdly, the quantity of kelp that can be made upon them.

Grazing farms, whether for sheep or cattle, must gradually be enlarged; and kelp, or merely agricultural farms, must as naturally become limited and confined in point of extent. The hay on many of the grass-farms, and sometimes the corn on arable grounds, is obliged to be dried by hanging on poles, trees, or rods (*fig.* 1156.), as in Sweden.

1136



4. *Implements.*

Some are nearly peculiar to the Hebrides, as the caschrom or crooked spade (*fig.* 1137.), which, in two parishes in the Isle of Lewis, entirely supersedes the use of ploughs in the raising of corn and potatoes. The great advantage of this instrument is, that it enables the operator to work in mosses or bogs, where no horses can walk, and in stony ground inaccessible to the plough. Many districts of Harris and of Skye would be unsusceptible of tillage without it. Its superiority to the common trenching spade, or to any tool which penetrates the ground perpendicularly, is very great, resulting both from the ease with which the operator wields it, and the length of the horizontal clod which its powerful lever enables him to turn over.

The *ristle*, or sickle plough (a sort of paring plough), is used for cutting the strong sward of old land, or the tough roots of plants, which would otherwise greatly impede the passage of the plough.

The *clom-maik*, or wooden tongs, for drawing thistles, &c. differs little from those in use in England.

1137

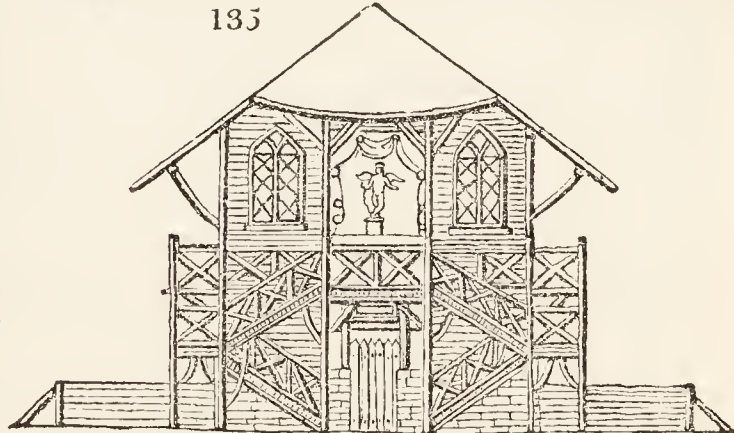


5. *Arable Land.*

Tillage is in its infancy over the Hebrides, in all the isles northward of Mull; excepting half a dozen farms in Skye, a part of M'Leod, of Rasay's estate, two farms in Uist, and a little lately done in Lewis, near Stornaway, and by Campbell, of Islay, on a small island between North Uist and Harris. These improvements have been carried on within the last fifteen years.

It would be rather ludicrous than useful to describe the tillage generally practised in the Hebrides; and, accordingly, we shall not dwell upon it, or insult the common sense of the natives, by seriously requesting them to abandon the many barbarous customs which have so long disgraced their country. A man walking backwards, with his face towards four horses abreast, brandishing his cudgel in their noses and eyes, to make them advance to their enemy, followed by a ristle-plough employing a horse and two men, the three commonly altogether superfluous, still followed by four horses, dragging clumsy harrows, fixed by hair ropes to their tails, and almost bursting their spinal marrow at every tug and writhing of their tortured carcasses. All this cavalcade on ground unenclosed, undrained,

135



and yielding at an average little returns for the seed sown, and sometimes lost altogether by the depredations of cattle, or by accident in a late harvest, is a barbarous spectacle, which must gradually vanish. It will soon give way, as it has already done in Islay, Colonsay, and part of Skye, to improved systems of tillage.

6. *Gardens and Orchards.*

It is not to be expected that much should be done in gardening, in a district of which by far the greater part of the proprietors are non-resident, nor is the climate suitable for that art. The winds are too violent, and the sun too shy of showing his face. Until trees and other sorts of shelter become, therefore, more general, the gardens and orchards of the Hebrides will probably be little more than an empty name.

7. *Woods and Plantations.*

In the sixteenth century it appears most of these isles were covered with woods, and even so late as Buchanan's time. One exhilarating remark, however, occurs to the traveller who traverses those bleak and woodless recesses, amidst the melancholy impressed upon him by comparing their present aspect with the description which he reads in Buchanan and Monro, namely, that where trees have formerly grown they will grow again; and that any regions which were once sheltered and adorned by the hand of nature, may still be in a far higher degree improved and embellished by the industry of man.

In Bute the late Lord Bute, in Islay Campbell of Shawfield, and in Skye Lord Macdonald, have planted extensively and successfully, and other proprietors are following the example. The present Marquess has almost naturalised the turkey in the plantations of Bute Park.

8. *Live Stock.*

The ancient Hebridean breed of cattle is now no longer to be found. Some persons imagine it to be the Skye, others the Mull, and others again the Lewis or Long Island variety. A person habituated to accurate observations on cattle, can easily distinguish those different breeds from one another, and all of them from the larger breed now introduced into Islay, Colonsay,

say, and some parts of the Long Island, especially Barray, by persons who pay attention to so important a department of agrestic economy.

Sheep. Only lately attended to. There are now three different breeds to be met with in almost all the larger islands, viz. 1. The native aboriginal breed, common to the whole Hebrides forty years ago, and still more numerous than the other two breeds taken together; 2. The Linton, or black-faced sheep of the south of Scotland; and, 3. The well known, fine-wooled, Cheviot breed. The historian Laing has a large flock of Merinos in the Orkneys.

Horses. The Hebridean breed of horses resembles that which we find in almost all countries of the same description of climate and surface. It is small, active, and remarkably durable and hardy. It possesses the prominent marks of perfection in this sort of animal, *i. e.* it is strong and nimble, of a good form and proper size for its work, healthy, patient, good-tempered, and very easily kept in good condition. It is found in the Highlands of Scotland, in Wales, Norway, Sweden, Switzerland, Tyrol, Hungary, and Transylvania, and with little variation in shape and size, in all the hilly districts of Europe. The average height of what are deemed sizeable horses is from twelve to thirteen hands; but that of the lower tenants' horses in Mull, Jura, and the northern isles, rarely exceeds eleven or twelve hands. They are handsomely shaped, have small legs, large manes, little neat heads, and manifest every symptom of activity and strength. The common colours are grey, bay, and black; the last-mentioned colour is the favourite. Excepting in Islay, and in a few gentlemen's farms, not exceeding two dozen in number in all the Hebrides, very little has hitherto been done for bringing this breed to perfection, or preventing it from degenerating.

The breeding of horses for sale is not carried on to a considerable extent in the Hebrides, nor does any of them export at an average of ten years more than it imports, excepting Islay, and perhaps Arran and Eigg.

Hogs. Considerable numbers of hogs are now reared in the Hebrides, where the ancient prejudice against pork has gradually vanished, since their more intimate connection with the lowlands of Scotland and England.

Goats still maintain their ground on several islands, and in certain circumstances constitute a valuable stock. But wherever wood is to be reared, and enclosures guarded and preserved with attention, they must be banished; for, being more a browsing than grazing animal, the goat will strain every nerve

to crop twigs and plants of every description, and is a mortal enemy to every species of growing woods.

New species, or varieties of stock. Excepting the ass, and perhaps the mule, it is not clear that this extensive region would gain by introducing any new sorts of domesticated animals; indeed, the great want felt by the Hebrides is not that of animals, but of food in winter and spring for those which they possess. The native breeds of cows and horses are, perhaps, the very best possible for the country to support, and may, by due attention to feeding, and to selecting the strongest and handsomest pairs as breeders, be improved to an indefinite pitch of excellence. The breeds of sheep already recommended and described may be improved, and reared to five times their present numbers, without seriously injuring the agriculture or other interests of the country; and a vast accession of wealth and food might accrue from breeding a competent number of hogs, for which these isles, abounding in potatoes, are extremely well adapted. But all these improvements must go on progressively and slowly, and they must advance in the train of other agricultural and economical improvements.

9. Political Economy.

Roads much wanted, and, excepting in Bute, Islay, and Skye, in a very wretched state. No iron railways or canals. No equal portion of European population, not even excepting the Russians, and most uncivilised Poles and Croats, possesses so few manufactures as the people of the Western Islands of Scotland. This is, among other causes, a principal source of poverty and depression of the people. It makes the little money acquired by the fisheries, and drawn in exchange for black cattle, kelps, and the other productions of the district, continually flow out of it, and prevents that gradual advancement in wealth, comfort, and agricultural and economical improvements, which are conspicuous in all other parts of Scotland, and although it does not absolutely keep these isles in a quiet state, it greatly retards their progress.

Kelp is a well known Hebridean manufacture, and is in an advancing state. Macdonald, of Staffa, is distinguished for his attentions to this branch of Hebridean economy; and has accordingly preserved for his kelp a character, which enables him to dispose of it at a higher price than the average of the Hebrides obtains. This results principally from its being begun early in summer, its being duly attended to in the carriage and drying of the sea-weeds, and especially its being kept clean and unmixed with clay, sand, stones, and all other impurities, which greatly diminish the value of kelp on many Hebridean estates.

7860. The ORKNEY ISLANDS are thirty in number, and contain about 384,000 acres.

Many of them are uninhabited, and only afford pasture for sheep. The soil is generally peat moss or bog, but sand, clay, and gravel are found in some of the valleys. The soil is seldom more than one or two feet in depth, lying on a bed of rock. Husbandry is in a very backward state. The plough used is generally the single-stilted one; the manure is chiefly sea-weed, and on the quantity procured the farmer relies for his crop. The plan of husbandry is to till very shallow, and to harrow sparingly. Fallows are rarely used, and a proper rotation of crops never followed. Black oats are sown about April, and barley early in May; the crop is generally gathered in August; and if it remain till after the beginning of September, it is frequently lost from the violent gales and storms which follow the autumnal equinox. Except some stunted birch and hazel trees, and a few juniper bushes, scarcely a tree or shrub is to be seen; the climate is variable, and not healthy; violent storms of wind and rain, mingled with snow, visit the islands even in the month of June, and check the progress of vegetation. From the shortness of the days in winter, the sun in December and January not being more than four hours above the horizon, very little agricultural work is done in that season. The summer days are proportionably long, and it is light enough to see to read at midnight. The principal animals are small horses, black cattle, sheep, pigs, and rabbits. The sheep are very numerous, and it is calculated that there are above 50,000 in the islands; their flesh is, however, coarse and dry, and, from their proneness to feed upon sea-weed, it has a dis-

agreeable flavour. Till within the present century, the Orkney sheep were suffered to run wild about the hills, without any care being taken of them; when in this state, the weight of the entire carcass rarely exceeds twenty-five or thirty pounds, and the wool seldom one pound and a half; when carefully treated, however, they grow much larger, and the flesh becomes very good.

One of the greatest curiosities in these islands is the circumstance of large seeds being frequently washed on shore by the Atlantic. They are called Molucca or Orkney beans, and are supposed to be of American and West Indian origin. Pods of the *Mimosa scandens* are the most common. Strange fishes, marine shells, and even exotic fowls, are also sometimes cast on shore in violent weather. There are many varieties of wild fowl in the Orkneys, and eagles are not only common, but so large as to make great havoc among the lambs. The islanders have a law, by which every man who kills an eagle is entitled to a hen from every house in the parish where it was killed. The corhy (*Córvus Córnix*) is also a dangerous enemy to the newly dropped lambs. The inhabitants on the coast live by fishing and making kelp. The staple article of trade in the other parts of the islands, is wool, which used formerly to be torn from the sheep by the fingers; the sheep are now shorn, and as they are never smeared (except when actually ill of the scab), the wool is remarkable for its softness. (*Edin. Gaz.* 1827. *Blakie on Sheep Husbandry in Orkney, in Trans. Highl. Soc.* vol. iv. p. 599.)

7861. The SHETLAND ISLES are about eighty-six in number, of which forty are inhabited; the whole contain about 48,000 acres, nearly equally divided between pasture land and arable.

The climate is very humid, and cold northern and easterly winds are extremely prevalent. Winter may be said to occupy full six months in every year, and if the harvest is not over in September, the crops are generally spoiled from tempests. There is a great diversity of soil; often deep moss on a bottom of sand, though sometimes the moss or peat is only a foot thick on a bed of clay. There are scarcely any trees or shrubs, excepting juniper, and occasionally a few mountain ash; the roots of large trees are, however, often discovered on digging deep into the ground. Turf and peat are used for fuel. The Shetland horses are well known; they are very small, rarely exceeding ten hands in height, and are celebrated for their spirit, and their power of enduring fatigue. The cattle are also very small, though they feed well, and weigh astonishingly heavy, in proportion to the size of their bones; they give generally about three English quarts of milk a day, though in rich pastures they sometimes produce double that quantity. The number of sheep kept in the Shetland Isles is calculated to be between 70,000 and 80,000. The wool is very short, and though generally fine, is sometimes nearly as coarse and hairy as that of a goat. The islands are well supplied with fish, and have

multitudes of aquatic birds; the inhabitants are much annoyed by eagles and other birds of prey; there are no rivers, but abundance of lakes and rivulets, which afford an ample supply of fresh water. The chief employment of the inhabitants is in the manufacture of woollen stockings and gloves of extraordinary fineness, and in their fisheries, from the produce of which they annually export about 1000 tons of cod, tusk, and ling; they also export annually about 500 tons of kelp. Agriculture is at a very low ebb; the farming implements are of the worst possible description, and of the rudest construction; the farm-houses are wretched hovels, and the roads mere foot-paths. The small portion of land, however, which is tolerably well cultivated, is very fertile. Granite, freestone, and limestone are abundant, as is the beautiful and comparatively rare stone, called diallage rock. Bog iron ore abounds: a copper mine was formerly worked, but has been abandoned; very recently chromate of iron has been found at Unst. Various other minerals are found upon the islands; and occasionally porcelain earth; but no potteries have as yet been established. (*Edin. Gaz.* 1829.)

SECT. IV. Agricultural Survey of Ireland.

7862. IRELAND, the largest island in Europe next to Britain, contains above 20,000,000 of acres, much less varied in surface, soil, and climate than the latter island. There are several mountainous or hilly districts, chiefly in Ulster in the north, and Munster in the south, and very extensive flat bogs in the middle districts, and upland bogs or moors wherever there are hills or mountains. All these bogs, whether low or high, are on good soil, which, indeed, may be considered in connection with the moist warm climate as their chief cause. Nine tenths of the soil is a loam on a limestone bottom, fertile, or capable of being rendered so at little expense; the remainder is chiefly thin clay or limestone. The bogs are here considered as mere coverings to soils; their surface exceeds 1,000,000 of acres. The climate is

milder and more equable than that of England; and with the dry soil, as Wakefield remarks, is admirably adapted for pasturage and occasional aration.

7863. *Of the agricultural circumstances of Ireland generally*, we have already given a condensed account (807), and shall here submit some brief notices as to each county. These unavoidably present a degree of sameness incompatible with much interest or instruction. There are agricultural surveys of but a few of the Irish counties; so that we have drawn our resources principally from the copious and highly interesting work of Wakefield, and some more recent statistical writers and tourists. When the first edition of this Encyclopædia appeared, the statistical portion, as far as respects Ireland, was objected to in the Irish Farmer's Journal, as representing the agriculture of Ireland as being in the same state in 1823 as that in which it was in 1816, the date of Wakefield's Ireland. We have noticed this in the *Gardener's Magazine* (vol. iii. p. 229.), and have, since then, used every exertion in our power to procure later information from books or correspondents, but without much success. In fact, from all that we have been able to learn, we are compelled to conclude, that even now (1830) agriculture in Ireland is not materially different to what it was in the time when our text-book (Wakefield) was first published.

7864. DUBLIN. 228,211 acres; one eighth in mountain and waste, a tenth in buildings, roads, rivers, &c., and the remainder in arable and pasture. (*Archer's Statistical Survey, &c.* 1801. *Sup. Encyc. Brit. Edin. Gaz.* 1827.)

The *climate* of this county is drier than that of some others; east and north-east winds are less frequent than in England, but storms from the south-west and west are more frequent. Average number of dry days in Dublin for ten years, 179; or nearly half the year wet, and half dry.

The *soil* is generally shallow, and the substratum almost universally a cold clay. There is very little turf bog in the northern parts, but some considerable tracts among the mountains in the south. Freestone, granite, Irish slate, ochres, potter's clay, marl, beautiful pebbles, porphyry, crystals, limestone, and limestone gravel, abound in various parts.

Landed property in this county is a much more marketable commodity than in most other districts of Ireland. There are here no large territorial domains. Leases vary in their terms, but commonly include a life, for the purpose of creating a vote.

Farms are in general very small near the city, seldom more than twenty or thirty acres; but at a distance, from 50 to 150 acres.

The farm buildings are, for the most part, very insufficient. Near the city, the fences are of white thorn; but in the remote parts, they are nothing more than a bank and ditch. Lime, limestone gravel, and marl are used as manures. The city of Dublin might afford the means of enriching a tract of several miles around it; but its street dung is so little valued, that it is

sometimes brought to Scotland by coasting vessels as ballast, and much of it is thrown into the Liffey.

On the *arable lands*, two crops of wheat in succession, and after these two of oats, without fallow or green crop, are frequently taken, according to Archer. Oats and potatoes are the standard crops. Barley is not cultivated extensively. The natural pastures are, with few exceptions, of an inferior quality. There are few or no flocks of sheep in the possession of farmers. In the city, and within four miles of it, about 1600 cows were kept in May, 1801, according to Archer, where there were formerly near 7000. The old Irish breed of cows is almost extinct, and their place is supplied by the short-horns and other breeds from England. Fuel is scarce and dear; peat and bog often cannot be procured, and the tenant is obliged to substitute straw, or any other combustible material that he can get.

There is a considerable *salmon fishery* on the Liffey, in which also abundance of eel and pike are caught. There are sea fisheries of herrings, white fish of different kinds, and oysters both in natural and artificial beds; the shells of some of the fed oysters have been found as large as a horse-shoe.

The *manufactures* of the county are chiefly of linen of different kinds, but they are of little importance. The colonial commerce with Dublin is considerable.

7865. WICKLOW. 500,000 acres, in great part mountains and bogs, and without inhabitants. (*Frazer's Survey of Wicklow*, 1801. *Sup. Encyc. Brit.*)

The *climate* so mild, that the myrtle flourishes in such profusion, as to have been sometimes used for making stable brooms. The common laurel, Portugal laurel, and Arbutus attain a great size, and can scarcely be recognised to be the same shrubs. Dublin is supplied with early potatoes and house-lamb from the sea-coast of Wicklow, the climate of which, according to Mr. Wakefield, is decidedly different from that of the rest of Ireland. This is the only part of that country where he ever saw grapes growing out of doors.

Metallic ores are supposed to abound; copper and lead have been worked, and gold has been found.

There are no navigable rivers or extensive lakes. Some of the streams precipitate themselves from considerable heights, forming beautiful cascades; the most remarkable one is at Powerscourt, where the water falls from a height of 360 feet.

Landed property in the centre of the county in large estates:

Earl Fitzwilliam's nearly 100,000 acres. The sea-coast is much divided, and abounds with villas, the temporary residence of the wealthy citizens of Dublin. "It appears to me," says Wakefield, "to contain more gentlemen's seats than the same space in the vicinity of London." The common period of leases is twenty-one years and a life. Potatoes, and all the usual kinds of corn, are cultivated; but turnips, clover, and other ameliorating crops, only partially. Marl and limestone gravel are the principal manures. Irrigation is practised. A breed of fine-woolled sheep, peculiar to the mountains of this county, exhibit the only traces of a distinct race of short-woolled sheep in Ireland.

The *herring fishery* in the bay of Wicklow is the best in Ireland after Galway. Flannels are extensively manufactured, but scarcely any linen.

7866. WEXFORD. 597,760 acres, mountainous on the north and west, a light soil and tolerable cultivation on the east, and in other parts a cold stiff clay, unimproved by culture. (*Wakefield. Frazer's Survey of Wexford*, 1807. *Sup. Encyc. Brit.*)

The *climate* is mild and favourable to the growth of timber, which abounds here more than in most counties. There are some large myrtles in the open gardens.

The *landed estates* are large, from 2000*l.* to 10,000*l.* a year, and farms of various sizes; but there is little of that minute division which is common in other parts of Ireland; nor are there any rich grazing farms. Dairies, at which the principal article is butter, are numerous; but generally under bad management. The cows themselves are of a very inferior description; and the same character belongs to their sheep, which forms a very inconsiderable part of the live stock. In their modes of cultivation, however, the farmers here are more advanced than in many other parts of the island. The baronies

of Forth and Bargie have been long noted for their great crops of barley; beans, too, are cultivated with success, as well as clover and turnips; the drill system is common for potatoes, and preferred to any other method; and lime, though brought from a distance at a great expense, and also marl, are very extensively employed as manure. The tenantry, including the cottars, are accordingly in a much better condition, industrious, provident, and many of them comparatively wealthy. Here, as in Cork and Waterford, whole fields are kept under furze, which, in this mild climate, is pretty much used as fuel. The bakers employ it for heating their ovens, of which a considerable number are employed, as a good deal of wheaten bread is consumed in these counties.

7867. KILKENNY. 510,000 acres, mountainous, but with some rich and beautiful vales on the banks of the Barrow, Suir, and Noire, and a climate so mild that in winter the thermometer seldom falls below the freezing point, while in summer it ranges between seventy and seventy-five degrees. There is less humidity than in Dublin and Wicklow, as well as less of the east and north winds. (*Tighe's Survey of Kilkenny*, 1802. *Sup. Encyc. Brit. Edin. Gaz.* 1827.)

This county has many romantic situations, ornamented with country seats; and its flat districts, where the tillage farms are more extensive than in most parts of Ireland, present a prospect very different from what is often met with in that country.

The *soil* is for the most part on limestone of good quality, and some of the valleys of extreme fertility. There are very few bogs; for the land declining about 500 feet from the northern to the southern boundary, the water which falls upon the surface is carried off with sufficient rapidity to prevent its making the ground marshy. The largest colliery in Ireland is at Castle Comber, near the northern boundary of the county. It is a stone coal raised in immense pieces, but of a sulphurous quality, which renders it disagreeable, and sometimes noxious; and it is, therefore, less fit for being used in families. For this reason, and also from the great expense at which it is raised, English coal is used in preference, even within a few miles of the works. There are several quarries of marble, chiefly of a black colour, of which a few tons are exported. Excellent sandstone and manganese, and iron and lead ores, have been observed in different parts.

Property in land is in several large estates, and many of a moderate extent, not exceeding a rental of 2000*l.* a year. The principal proprietors are Lords Bexborough, Clifton, and Ormond. The leases are in general for three lives, and partnership leases are common, though prohibited on one of the largest properties. On this estate the tenant is allowed to transfer his lease to one individual, but not to divide his farm.

Of the *husbandry* the most important department is the dairy, which extends over the greater part of it. The most considerable dairies are in the district called the Welsh, or Walsh Mountains; a tract of dry grassy land fit for tillage, but still in its natural state, and not enclosed. About 2000 Irish acres of the land were held in 1800 by one family, who kept 120 cows. The cattle are not for the most part housed in winter, and only those that are about the time of calving get a little hay on the fields, where the horses also are kept all the year. They fatten pigs to the weight of five hundred weight. The produce of the best dairies is one hundred weight and a half, or three firkins of butter per cow, and each cow requires from one and a half to three Irish acres. The practice of letting cows to

dairymen, which is common in Munster, is but little known in Kilkenny, the cows belonging to the dairymen themselves, who, in some situations, breed them on their own farms, and in others prefer buying them at a proper age. Too little attention is paid to cleanliness in their dairies, especially in the northern district; and for this reason, according to Wakefield, though Irish butter, when fresh, is preferable to any in Europe, yet it "is in the lowest estimation in the London market, as it is almost always heavily salted, and very frequently tastes smoky, fishy, and tallowy." The cattle of this county are a mixed race from the native breed and the English long-horned, and their sheep have been, in some parts, improved by the Leicesters. The Merinos have been introduced within these few years by Messrs. Nowlan, the proprietors of a woollen

7868. KILDARE. 392,397 acres, four fifths arable, meadow, and pasture, and the rest bog. (*Rawson's Survey of Kildare, 1807. Sup. Encyc. Brit.*)

Part of the *Bog of Allen* and other similar tracts occupy a large portion of the western side of this county. The surface is varied by a number of small hills and gentle declivities; but for the most part it is flat and nearly level; and when viewed from a commanding station, presents a rich, and, on the banks of its rivers, a beautiful landscape. The Curragh of Kildare, extending to about 5000 acres, has been long celebrated for the softness of its turf and the fineness of its pastures. But the climate of Kildare is said to be more moist than that of any other part of Ireland, which, if the statement be correct, is a very unfavourable circumstance, as a clay soil prevails very generally, and much of it is exceedingly tenacious of moisture.

There are a few large *estates* in Kildare, particularly the Duke of Leinster's, which extends over a third of the county; and several proprietors, according to Wakefield, have from 6000*l.* to 7000*l.* a year; yet many are less considerable, and property seems to be more divided here than in most of the other districts in Ireland.

7869. KING'S COUNTY. 457,000 acres, half of it bog, mountain, and waste; and the remainder arable, meadow, and pasture, of a medium quality. (*Coote's Agricultural Survey, 1801. Sup. Encyc. Brit.*)

The *Bog of Allen* occupies a considerable tract on the north-east coast, and the mountains are on the side of Queen's County. The soil of the arable land is either moorish or gravelly; the former productive in dry, and the latter in moist seasons, but neither of them naturally fertile. Limestone and limestone gravel, the means of their improvement, abound every where. The pastures, though in many parts fine, are not luxuriant; better adapted for sheep than cattle, and very favourable to the growth of fine wool. Much of the mountain district has an argillaceous soil, thickly interspersed with rocks of sandstone, and a deep irreclaimable bog often occurs at its base; but towards the centre of this range, where limestone prevails, there is much good pasture; and here the base of the hills, which is composed of a stiff clay, produces abundant crops of corn.

Landed property is in large estates, and many of their owners do not reside; but much of the land is held on leases in perpetuity, and the holders of these form a respectable class. The principal proprietors are Lords Digby, Rosse, and Charleville. Farms were formerly very large, not unfrequently of the extent of 2000 acres; but their size has been diminished, and such as are considered large do not now exceed, on an average, 400 English acres. Many are as small as twenty acres, though the medium size of the smaller class may be double this. Most of the arable land is tolerably enclosed; chiefly with hedges of whitethorn, which grows here to a great size. Partnership leases and sub-tenancy are less common than in some other parts of Ireland; yet the condition of the tenantry and the peasantry does not seem to be materially more improved. The farm-buildings of every description are generally very bad; the cottages in particular; and yet those who have been long accustomed to these miserable cabins are said to prefer them to more comfortable dwellings (*fig. 1158.*), which, after having

7870. QUEEN'S COUNTY. 384,000 acres, generally of a level surface, three fourths of which is of a productive soil cultivated, and the rest bog and waste. (*Coote's Agricultural Survey, 1801. Sup. Encyc. Brit.*)

Coal of the Kilkenny kind (7867.) is the only mineral worked; but there is iron ore, freestone, marble, &c. in different parts. The Barrow and Nore are navigable rivers.

Estates are from 5000*l.* to 15,000*l.* a year, and upwards. Some of the most valuable, having been let on perpetual leases, afford a large income to the lessees. It is these lessees who form the middle class of gentry, with clear incomes of from 100*l.* to 800*l.* per annum, obtained from tenants to whom their lands are sublet at rack-rent, and commonly in very small farms. Here, and in King's County, Wakefield observed some of the

7871. CARLOW. 220,098 acres, of undulating surface, with some hills and mountains; the lowlands a fertile loam, and the uplands a light gravel; one tenth in mountains and bogs. (*Wakefield's Statistical Account, &c. Young's Tour, &c. Sup. Encyc. Brit.*)

The *minerals* are various, but little known.

There are no large *estates* in this county; and very little minute description of property. The hiring tenant is generally the occupier, except of small pieces. There are some excellent flocks of long-wooled sheep. Four sheep of the Irish breed and five of the English are called a "collop," and three collops are allotted to two acres of the best land. For its dairies, Carlow is not excelled by any county in Ireland. The farmers spare no trouble or expense to procure good cows. From twenty to fifty are generally kept; and during the season each cow produces, on an average, about one hundred weight and a half of butter. The dairy system pursued in Devonshire, Dorsetshire, and some of the northern counties of Ireland, of letting cows to dairymen, is followed here; but this custom was more prevalent when the Catholics could not legally purchase land, as they then employed their capital in hiring cows. The butter made in Carlow is divided into three sorts, according to its quality. The first in point of quality is sent to Dublin and England, and thence exported to the East and West Indies.

factory, who have now 600 of the pure race; and they find that both the quality and the weight of the fleece have improved since the sheep were imported. The usual corn crops are raised here, but clover and other green crops not in a suitable proportion. It is the custom to work oxen intermixed with horses, in teams of six, or three pair deep, the oxen placed foremost. Yet the fallows are better managed here than in any other part of Ireland. Irrigation has been practised for many years, but not extensively. (*Sup. Encyc. Brit. Kilkenny.*)

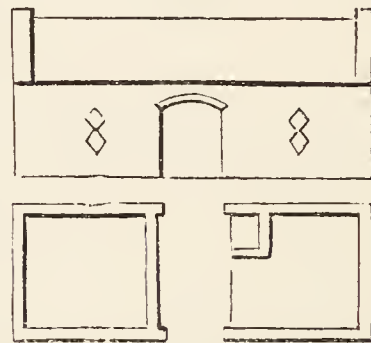
Salmon are caught in the rivers, and sent to Dublin packed in boxes of ice. Woollen is the chief manufacture. Messrs. Nowlan and Shaw produce excellent superfine cloths, from an establishment as celebrated in Ireland as that of Owen at Lanark is in Scotland.

The common *size of farms* is from ten Irish acres to 200; and these farms are frequently held in partnership. Large farms, however, are less rare here than in the arable tracts of the other counties. The leases were formerly for thirty-one years, but are now mostly for twenty-one years and one life. All parish and county taxes are paid by the tenant. With few exceptions, the course of cropping is the same as it has been for a century, viz., fallow, wheat, oats. Potatoes are universally cultivated. Oxen are employed in ploughing, and horses for carriages; but in many instances oxen and horses are mixed together in the plough team, which sometimes consists of six, and never less than four animals. A number of mules are also kept on the farms.

There are several streams and two canals. A woollen manufactory at Celbridge; and a catholic seminary at Maynooth for above 200 students.

been erected by some of the proprietors, were for some time allowed to stand unoccupied.

1138



good construction. The threshing-machine has been in use in this district for about twenty years.

The *leases* were formerly for thirty-one years, or three lives; but the more common period of late is twenty-one years, to which the life of the tenant in possession at the end of it is frequently added. Some tenants hold for lives renewable for ever, paying a renewal fine equal to half a year's rent, or more, on the fall of every life. Modern leases often contain a prohibition against alienating. Nothing is so much complained of among the tenantry as the mode in which tithes are collected.

There are no considerable *manufactures*, no fisheries, and no minerals worked.

best farming in Ireland, with much more attention to a systematic course of cropping, and to keeping the land in good heart. Oxen and horses are used for the plough, the farmer generally preceding the latter. A good deal of cheese is made here for the Dublin market. In other respects the rural economy of this district does not differ materially from that of the Irish counties already described.

The *manufactures* are linen and coarse woollens, but to no great extent.

It is highly esteemed in the London market, where it is often sold as Cambridge butter. That of the second quality is exported to Spain, and the worst to Portugal. It is all packed in large casks, weighing upwards of three hundred weight.

There is not much wheat grown, and it is not of a bright colour or very good quality; but the barley of Carlow is excellent; according to Young, the best in Ireland. At the time of his tour it was the only interior county which produced it; and at present more is grown here than in any other part of the kingdom. It is principally consumed by the illicit distilleries in the north of Ireland, by the breweries at Cork, or by the malting houses at Wexford. The potatoes grown in Carlow are excellent. There is little or no flax. The county is tolerably wooded. In the vicinity of Carlow a great many onions are grown, which are sold all over Ireland.

In Carlow, coarse cloth, reaping hooks, scythes, shears, &c. are made. At Leighlinbridge is one of the largest corn mills in Ireland, capable of grinding more than 15,000 barrels a year.

7872. EAST MEATH. 526,700 acres, of low, flat, rich surface; a clayey or loamy soil on limestone or gravel, with little wood, few mansions, and only one twelfth of bogs. (*Curwen's Observations*, 1818. *Thomson's Survey of Meath*, 1802. *Sup. Encyc. Brit. Edin. Gaz.* 1827.)

The landed property of Meath is divided into large estates, a great many of which yield an income of upwards of 2000*l.* a year. These are for the most part let out on leases of twenty-one years and a life; but on some of them there are leases in perpetuity, which have now become more valuable than the freehold property.

Grazing was, till very lately, a more important object in this county than tillage. Many persons fattened from 500 to 500 cows in a season, besides bullocks and sheep. These they purchase at the beginning of the grass season, and dispose of during the summer and autumn, as they are ready, instead of keeping a regular stock all the year. The pastures are considered too valuable to be applied to the rearing of stock. Dairying is not carried to any extent, and the butter made here is said to be held in little estimation. In some instances, where farms are let out for the dairy, the landlord supplies a succession of cows in milk, horses, and land, and the tenant furnishes labour, utensils, &c., paying at the rate of from 6*l.* to 7*l.* 10*s.* per annum for each cow. The English long-horned cattle were introduced many years ago into this district, which now contains some of the best specimens of the breed. Some marshes on the Moynalty river feed an immense number of horses in the summer season; and the Kilcrew hills, in the western angle adjoining Cavan, are remarkable for fattening sheep. The sheep are brought from other counties, and, like the cattle, the same stock is kept only for a season.

Tillage farms are larger here than in most parts of Ireland; but, according to Curwen, the system of management is little better than on the small farms of other districts. The houses and fences are, for the most part, of the worst description, especially the cabins of the farm labourers, which are miserable mud-walled hovels, sunk below the level of the ground adjoining, and occupied by cows and pigs, in common with the family. The principal food of this class is potatoes with churn-milk, and occasionally oatmeal; butcher's meat being rarely used even among the farmers; and, to add to their privations, fuel is very scarce in different parts of the county. An uninterrupted succession of oats and other corn crops for several years is common; in a few instances even for twenty years. The common rotation is wheat, oats, fallow, potatoes, clover, all without the application of manure. It is customary to work horses intermixed with oxen, of which six are generally yoked together, threepair deep, to a very ill-constructed plough; yet, notwithstanding this management, the wheat crops are in some parts excellent. Agriculture has, of late years, extended very much, and at present nearly three fourths of the county are under tillage.

Manufactures do not afford employment to any considerable part of the population, though here, as in most parts of Ireland, that of linen is carried on to some extent; and also the weaving of cotton. On the Blackwater and the Boyne there are several extensive flour mills.

7873. WESTMEATH. 378,880 acres of surface. The surface of this district is exceedingly diversified with woods, lakes, streams, bogs, and rich grazing lands; in no parts mountainous or flat, but gently undulating, or rising into hills of no great elevation. Some of these are cultivated to their summits, and others covered with wood, presenting, in several parts, some of the finest scenery in Ireland. (*Wakefield's Statistical Survey of Ireland. Sup. Encyc. Brit. Edin. Gaz.* 1827.)

The principal river is the Shannon; and there are a number of beautiful lakes well stocked with fish; the trout in Lough Dim are said to have an emetic quality. One of the largest of the lakes is full of wooded islands.

There are few large estates, but many gentlemen of moderate fortunes, from 2000*l.* to 5000*l.* a year, most of whom are resident. The leases are commonly for twenty-one years and a life, though in some instances for thirty-one years and three lives. A great many fine long-horned cattle and long-wooled

sheep occupy the grazing grounds, which extend over much of the best part of the district. Tillage is accordingly upon a limited scale, though more corn is raised than the inhabitants consume; and besides the crops common in other places, flax, hemp, and rape are cultivated, with clover and turnips; the two latter, however, not generally. The soil is mostly light, but in some parts it is rich and deep.

Few or no manufactures.

7874. LONGFORD. 234,240 acres, in great part bog, mountains, and waste; the climate on an average giving 140 dry days in the year. (*Wakefield, &c. Sup. Encyc. Brit.*)

Landed property is in estates of from 3000*l.* to 7000*l.* a year. Leases are commonly for twenty-one years and a life. Farms are, for the most part, very small, where tillage is the principal object; but only a small proportion of the district is under the

plough. It is chiefly occupied in grazing, in which the resident gentry almost exclusively employ the farms which they retain in their own hands. Some linen manufacture.

7875. LOUTH. 177,926 acres, mountainous towards the north, but in other parts undulating and fertile, with little waste land, no considerable lakes, and a great number of gentlemen's seats, of which Colton is the chief. (*Wakefield. Edin. Gaz.* 1827.)

Landed property is in estates from 1500*l.* to 2000*l.* per annum. Farms are, in general, larger than in most other parts of Ireland; but there are still many very small; in some parishes, scarcely one above twenty-five acres, and in others they do seldom extend to eighty acres. As the land is chiefly occupied in tillage, little attention is paid to the improvement of cattle and sheep; of the latter, though a few are kept on most farms, the number is inconsiderable. Wheat and oats are the principal corn crops, barley being very little cultivated. The other crops are potatoes, flax, and a little hemp. Clover and turnips are almost confined to the farms of proprietors. It is only on these that the general management is good; that of the common farmers being, for the most part, slovenly; and their lands requiring heavy dressings of lime and marl to keep them

productive. Yet a spirit for agricultural improvement has lately happily appeared in this county, and many of the tenants are in easy circumstances, well clothed, use meat in their families, and in every thing but their houses and farm buildings are in a condition superior to that of their brethren in most other parts of Ireland. It is common to renew the leases some time before the old ones expire, so that the tenants are not often changed; but fines are frequently paid on these renewals, which carry away much of the capital that should be applied to the soil. Tithes are very seldom taken in kind; their value is ascertained about the end of harvest, and the tenants grant their notes for the amount, which, though payable in November, is, in some cases, not exacted till almost twelve months after. The linen manufacture is carried on to a considerable extent.

7876. WATERFORD. 454,400 acres, the greater part hilly and mountainous, but rich and productive on the south-east; the climate so mild, that cattle sometimes graze all the year round. (*Wakefield, Curwen, &c. Sup. Encyc. Brit.*)

Some very large estates, of which the most extensive belongs to the Duke of Devonshire. Leases are commonly for twenty-one years and a life; and on the banks of the rivers, where the land is most valuable, farms are small. According to Wakefield's information, "In this county, when the eldest daughter of a farmer marries, the father, instead of giving her a portion, divides his farm between himself and his son-in-law; the next daughter gets one half of the remainder; and this division and subdivision continues as long as there are daughters to be disposed of. In regard to male children, they are turned out into the world, and left to shift for themselves the best way they can." The rent is chiefly paid from the produce of the dairy, which is conducted on a greater or smaller scale over all the county, and from the pigs, which are partly fed upon its offals. Some of the dairy farmers, most of whom are in easy circumstances, pay 1000*l.* a year of rent; and a great deal of butter is

made, even among the mountains, where small cows, suited to the nature of the pastures, form the principal stock. In the neighbourhood of Waterford, cows were let for sixteen pounds, eighteen pounds, and even twenty pounds, for the season. There are very few sheep, and those of a bad description; and, comparatively, but a small portion is in tillage. Where lime is used as a manure, it must be brought from a distance, as there is no limestone to the east of Blackwater, and it costs upwards of five pounds for an acre. Orchards are numerous on the banks of this river, and extensive plantations of timber-trees have been formed in various parts. Furze is so much used as fuel, that whole fields are kept under this shrub for the purpose.

Hogs are an important branch of trade at Milford Haven; glass and salt the principal manufactures.

7877. CORK. 1,048,799 acres of Irish plantation measure of greatly varied surface; bold, rocky, and mountainous on the west, rich and fertile on the south and east, romantic and sublime in many places, and one fourth part waste. (*Wakefield. Townsend's Survey of Cork*, 1810. *Sup. Encyc. Brit. Edin. Gaz.* 1827.)

The climate is mild; but a very general opinion exists that it is changing for the worse.

The rivers of this county flow with rapidity for the most part; a circumstance unfavourable to their being rendered navigable, but presenting many eligible situations for the erection of machinery.

The most useful fossils are limestone, marble, and slate; coal and ironstone have been discovered, but not worked to any extent.

Estates are generally large; tillage farms are very small, seldom above thirty acres; and, when they are larger, often held

in partnership, and the shares of each further diminished by the common practice of dividing the paternal possessions among the sons. The leases used to be for thirty-one years, or three lives; but of late the term has been reduced to twenty-one years, or one life; and the farms, instead of being let out to middlemen, who used to relet the land in small portions to occupiers on short leases or at will, are now held in most cases by the occupier from the proprietor himself. There is here the usual minute division of tillage lands, cultivated by the spade in preference to the plough; the usual dependence on potatoes, as the common and almost exclusive article of food; with miser-

able cabins, crowded with filth, poverty, and indolence. The crops are potatoes, in favourable situations, succeeded by wheat and oats, for one or more years; sometimes barley follows the wheat. Flax is cultivated in many small patches. Hemp very rarely. Turnips and clover are seldom to be seen on tenanted lands. Sea-sand, sea-weed, and lime, form a useful addition to the stable and farm-yard manure; which is, however, in many cases, allowed to be washed away by the rains, and greatly reduced in value by careless management. Paring and burning is practised in every part of the county, as an established mode of preparation for the first crop in the course. The implements of husbandry are generally bad: the common Irish plough and harrows, seldom furnished with iron tines, drawn by horses or mules, and, in a few instances, by oxen; wheel carriages have become common. A considerable number of dairies are kept in the vicinity of the city of Cork, where the produce, in the shape of butter and skim-milk, finds a ready market. In general the cows, which are chiefly of the half Holderness breed, are

let out to a dairyman, at a certain rate for each, by the year; yet many farmers conduct the business of the dairy themselves. The average number of cows in a dairy may be from thirty to forty. A few sheep are kept on every farm, commonly in fetters, and upon the most worthless pastures. Proprietors have introduced stranger breeds, and find them to answer; but sheep can never become an object of importance in a district where farms are so small.

Tithes, of which no inconsiderable part are lay property, are generally paid by a composition with the farmers. The usual mode is to have them valued before harvest, and to appoint days of meeting with the parishioners, for the purpose of letting them.

The principal manufactures are sail-cloth, duck, canvass, and drilling; osnaburgs for negro clothing; coarse woollens; spirits at several large distilleries in Cork; and gunpowder in the neighbourhood of the same city, the only manufactory of that article in Ireland; it belongs to Government.

7878. TIPPERARY. 882,398 acres, diversified with heaths, mountains, and fertile vales; of which the Golden Vale is among the richest land in the kingdom. The climate so mild, that cattle graze out all the year. There are 36,000 acres of bog in this county, including part of the Great Bog of Allen. From the survey made by Mr. Ather, under the direction of the commissioners for enquiring into the nature and extent of Irish bogs, it appears that this waste land might be easily drained. (*Wakefield, &c. Sup. Encyc. Brit. Edin. Gaz.*)

Minerals. Slate, lead, and coal are worked.

Estates are of various sizes, some of them very large, but a greater number of a medium extent, worth from 4000*l.* to 6000*l.* a year. Of the proprietors, the influence of Lord Llandaff is by far the most considerable, though several others have estates worth from 10,000*l.* to 15,000*l.* a year and upwards. The graziers here, as in Roscommon, have leasehold properties, frequently of much greater value than the freeholds, of which, also, they often become the purchasers. Properties of this description, worth from 2000*l.* to 4000*l.* a year, are very common.

Tillage farms, however, are generally of small extent, one of ninety Irish acres being thought large; yet the management is, in many instances, more respectable than in most other parts of Ireland. But the principal business is grazing, every variety of this kind of land being found here. The exemption of graz-

ing land from every kind of tithe operates as an encouragement to persevere in this system. Leases are commonly for twenty-one years and a life. The cattle, which are long-horned, may be ranked with the best in Ireland, and many of the fine flocks of long-woolled sheep are not inferior, in Wakefield's opinion, to those of Leicestershire. The rich lands produce a kind of flax, very different from that which is raised in the north: it grows to a great height, and appears to be exceedingly well adapted for sail-cloth.

The manufacture of broad-cloth is carried on to some extent at Carrick; and that of linen, worsted, and coarse woollens, as branches of domestic industry. But the wealth of this extensive district chiefly consists in its cattle and sheep, corn, and other land produce.

7879. LIMERICK. 622,975 acres, of low-lying fertile lands, surrounded by higher grounds. (*Wakefield, &c. Sup. Encyc. Brit. Edin. Gaz. 1827.*)

Landed property is in large masses, generally let to tacksmen, on long leases, and sub-let almost *ad infinitum*. The land seems to be of greater yearly value than in most parts of Britain at a distance from large towns; for, according to Wakefield's information, the green acres would have let, in 1808, for three guineas the Irish acre, or almost forty shillings the English. Considerable farms brought five guineas the Irish acre, and in some instances more. The rent of the mountain land had increased in a still greater proportion than the grazing and corn farms. One grazier held land of the value of 10,000*l.* a year; and in one season slaughtered, in Cork, 800 head of cattle. Many of the best long-horned cattle of the United Kingdom are fattened here, and also a considerable number of sheep. Two-year-old wethers sold then, without their fleece, at from 2*l.* 10*s.* to 3*l.*

Only a small proportion of the land is in *tillage*; the produce of this, and some of the adjacent counties, in proportion to the seed, is stated by the same author to be at a medium: of wheat ten, bere seventeen, barley twelve, oats nine, and potatoes ten. Hemp was formerly cultivated extensively on the rich low grounds, called the Carcasses, on the banks of the Shannon; but this tract is now occupied in grazing. Flax of an excellent quality for sail-cloth is still grown in several parts. The common term of leases is thirty-one years and three lives. Great part of the provision and corn trade is possessed by the city of Limerick.

The soil is remarkably fertile, and consists chiefly of fine mould covering a light limestone gravelly soil: it produces all kinds of grain in abundance.

7880. CLARE. 962,560 acres, nearly half productive land, and the remainder moors, mountains, and bogs, with more than 100 lakes interspersed. The climate, though moist, is not unfavourable to health and longevity; fevers, which sometimes prevail to a great extent here, being occasioned chiefly by the dampness of the houses, and inattention to domestic and personal cleanliness. (*Dutton's Survey of Clare, 1808. Sup. Encyc. Brit. Edin. Gaz. 1827.*)

Limestone abounds, and coal, ironstone, black marble, lead, &c., have been found, but not worked.

Landed property is in a few large estates, of which the most noted was that belonging to the Marquess of Thomond's heirs, lately sold and divided.

The *size of farms* varies greatly. Those under tillage are from one or two acres to fifty, but of the latter size there are few. Grazing farms extend from 100 to 800 acres, several of which, and sometimes in distant situations, are held by one individual. Frequently several persons join in the occupation of an arable farm, and have about ten acres each. The general term of leases from proprietors is for three lives or thirty-one years; sometimes, but not often, for three lives and thirty-one years; twenty-one years or one life, and twenty-one years and a life. The tenure of under tenants is variable, and often arbitrary.

All the different species of grain are cultivated with considerable success. Rape and flax, the former chiefly for its seed, and the latter for home manufacture, are sown to a moderate extent. Potatoes occupy a part of every farm, and their culture is conducted with more care and judgment than that of any other crop, though at a greater expense of time and labour than would be thought necessary in most other places. In regard to the kinds of crops cultivated, the greatest defect is in what are called green crops, corn being, with potatoes, the chief and almost the only objects of attention to the arable farmer; and turnips and cultivated herbage being either grown on a very small scale, or, as is the case throughout the greater part of the county, altogether disregarded or unknown. The corn crops thus necessarily follow each other, until the soil is exhausted; and where extra manure, such as sea-weed and sea-sand, both of which are used as manure with good effect, cannot be procured, it must be left in an unproductive state for several years afterwards. Potatoes are in most cases planted upon land that has been prepared by burning; and the same crop is sometimes taken for two years more without manure; in the fourth year wheat follows, and then repeated crops of oats, as long as they will replace the cost of seed and labour.

The *implements* in common use are generally rudely con-

structed, and imperfect as well as expensive in their operation; in many parts, even where the soil is light and dry, the plough is drawn by four horses abreast, with traces of rope, and collar of straw. But from the roughness of the surface, the poverty of the tenantry, and the minute division of farm lands, the spade is much more extensively employed than the plough, over all the arable land of this county.

The *pastures* of the Carcasses or low grounds, on the rivers Shannon and Fergus, are equal to the fattening of the largest oxen. This rich tract extends from Paradise to Limerick, about twenty miles, and is computed to contain about 20,000 acres, of a deep dark-coloured soil, over a bluish or black clay, or moory substratum; producing, owing to the indolence of its occupiers, along with the most valuable herbage, a great quantity of rushes and other useless weeds. The rent of this land for grazing was, several years ago, as high as 5*l.* per acre, equal to about 3*l.* 2*s.* per English acre, and for meadow, in many instances, much more. These meadows are said to produce at the rate of more than four tons of hay the English acre. The cattle of this county are almost all long-horned, good milkers, and very hardy. The sheep have been greatly improved in shape, by crosses with Leicester rams; but there is a general complaint that the quality of the native wool has been deteriorated. A vast number of mules are bred here; asses are very generally employed by the poorer classes; but little attention is paid to the breed of horses, which has degenerated.

Clare was formerly noted for its orchards, and for cider of a very fine quality, made from the celebrated cockagee apple, which is still found near the small town called Six Mile Bridge. "An acre of trees," says Young, "yields from four to ten hogs-heads per annum, average six; and, what is very uncommon in the cider counties of England, yields a crop every year." It does not appear from the latest accounts, that any considerable quantity of this cider is now produced here, though what there is seems to maintain its former character, and is held in great estimation.

Manufactures are yet in their infancy. All the linen made in the county is used for home consumption.

7881. KERRY. 1,128,320 acres, more than three fifths mountainous and waste; the sea-coast and islands being the most westerly land in Europe. Some of the mountains 3000 feet high. (*Smith's History of Kerry. Wakefield. Sup. Encyc. Brit. Bichen's Ireland, 1830, &c.*)

The mountains are chiefly occupied with young cattle and goats; sheep, apparently the most profitable animal in such situations, are neither numerous nor of a valuable kind; and the little cultivation to be found here is so generally performed with the spade, that, in some entire parishes, as Young assures us, there was not a single plough.

The prevailing soil in the low grounds is clay, of different qualities; some of it seems to be a species of pipe-clay, and other sorts might be converted into bricks and earthenware.

Estates are very large, both in extent and value; some of them, according to Wakefield, worth 30,000*l.* a year. Leases are in general for thirty-one years and three lives, and a considerable portion of the whole county is let to partnership tenants. Few of the tenants in the north quarter about Kerry head occupy so much land as to require them to employ labourers; they pay their rents by the sale of butter and pigs, and by turf which they carry to Limerick. It is the practice for farmers to hire large tracts, which they stock with cows, and these cows

are then let out to dairymen upon such terms as leave them but a very small return for their labour. The best corn land is about Tralee, and towards Dingle, where more flax is raised than in any other part of the county.

The principal articles which Kerry affords for export are its raw produce, beef, butter, hides, and tallow. It does not raise more corn than is necessary for its home consumption, and carries on no manufacture for sale but that of coarse linen, which is only on a small scale.

Agriculture is at a low ebb; and the general face of the country gives the impression of wildness and discomfort. Instead of hedges, mounds of earth and stone, called ditches, are every where to be seen; and as these afford but a slight protection against the trespassing of cattle, it is customary to tie the legs of each quadruped together with wisps of straw, and sometimes to yoke two together; even fowls and turkeys are thus bound. (*Bicheno.*)

7882. ROSCOMMON. 556,847 acres of flat surface, in some places sprinkled with rocks, and in many interrupted by extensive bogs; the richest land on limestone, and adapted either for aration or pasture. (*Wakefield. Sup. Encyc. Brit. Edin. Gaz. 1827.*)

Coal and iron works were formerly carried on, but are now neglected.

Estates were once very large; but they have been broken down in some instances, by the granting of leases in perpetuity; a practice which has given rise to a class of landholders, interposed between a few great proprietors on the one hand, and a numerous body of cultivators on the other.

Some of the best long-horned cattle and long-woolled sheep in Ireland fed, but there are few dairies. During the late war, its fine green pastures, under this management, afforded a very ample rent, and tillage was therefore conducted on a small scale; but the plough has been more in request since the

peace, both here and in other parts of Ireland; and the soil of such rich grazing lands, requiring nothing more than the common operations of tillage to yield large crops, the growth of corn throughout Ireland has been greatly increased; yet, within these few years, agriculture was here in a very backward state. "In Roscommon," says Wakefield, "I heard of horses being yoked to the plough by the tail, but I had not an opportunity of seeing this curious practice. I was, however, assured by Dean French, that it is still common with two-year-old colts in the spring." Potatoes, oats, and flax are the principal crops. There are several fine lakes, and the Shannon runs along nearly the whole of the eastern boundary.

7883. GALWAY. 1,659,520 acres of varied surface; above a third part bogs, mountains, and lakes, and very unproductive, and thinly inhabited. (*Dutton's Survey of Galway, 1824. Wakefield. Sup. Encyc. Brit., &c.*)

The east part of the county is flat, warm, and fertile, with many seats, though none of note. Rivers and lakes abound. Lough Reagh and Lough Coutra are fine pieces of water; the latter is said to possess all the beauties that hills, woods, and islands can impart to that feature of landscape.

Several large estates, affording an income of from 5000*l.* to 10,000*l.* a year, and upwards. One of these, the most extensive in the British Isles, stretches along the sea-coast for seventy miles. Only a small portion is held by absentees. A full third of the land is let on partnership leases, to an indefinite number of persons, very often twenty, who by law are joint tenants, and entitled to the benefit of survivorship. The leases are commonly for three lives or thirty-one years. "These people," says Wakefield, "divide the land and give portions to their children, which consist of a fourth or fifth of what they call 'a man's share;' that is, of the land which originally belonged to one name in the lease. A certain portion of the whole farm, or take, as it is styled, is appropriated for tillage, and this portion is then divided into lots, perhaps twenty or thirty. These lots are again subdivided into fields, which are partitioned into small lots, each partner obtaining one or two ridges; but these ridges do not continue in the hands of the

same occupier longer than the time they are in tillage. The pasture is held in common; and the elders of the village are the legislators, who establish such regulations as may be judged proper for their community, and settle all disputes that arise among them. Their houses stand close to each other, and form what is here called a village."

The *cattle* of Galway are long-horned and of an excellent description, fully equal, in the opinion of Wakefield, to any in England. But sheep form the most valuable part of their live stock; "some of the first flocks in the world," says the same writer, "are to be found in this county." The crops are the same as in other parts of Ireland, but potatoes are not cultivated to so great an extent. They plant potatoes on an oat stubble, or on ley that has been burned or manured, and follow with wheat, bere or barley, or oats; the latter kind of grain is not unfrequently taken after wheat and barley. Paring and burning the soil is very common. The greater part of the rent of some of the estates on the shore is paid from kelp, which is prepared in large quantities.

In common with the greater part of Ireland, Galway employs some of its people in the linen manufacture, and it seems to be the only manufacture in it worth notice.

7884. MAYO. 1,270,144 acres, in great part mountains, bogs, and lakes; half-heathy mountains, with valleys very fertile, but neither woods nor plantations, excepting on one or two estates. (*M'Parlan's Survey of Mayo, 1802. Wakefield. Sup. Encyc. Brit. Edin. Gaz. 1827.*)

Many valuable fossils; iron formerly made, but discontinued for want of fuel. Excellent slate; and petro-silex semilucidus, similar to what is used in the English potteries. The low grounds of the county are composed of limestone, or limestone gravel, and are equally well adapted to tillage or pasture.

The *estates* worth from 7000*l.* to 20,000*l.* a year; but their extent, owing to their containing a great proportion of waste land, is still greater than the ratio of their value.

The size of farms varies with the nature of the soil and surface; but, though several hundred acres are sometimes let out in one farm, yet, as the farms are commonly held in partnership, the space allotted to each tenant is generally only a few acres. As each of them keeps a horse, it is computed that there is one for every ten or twelve Irish acres. The leases are for different periods, fifteen years, twenty-one years, and one, two, and sometimes three lives, or thirty-one years.

Agriculture is in a very backward state. The plough, commonly drawn by four horses abreast, is of the worst descrip-

tion, and the harrows are often furnished with tines of wood, instead of iron. It is still the practice, in the mountain district, to yoke the horses by the tail. But in some of the baronies, the plough is seldom or never employed at all, the tillage being performed by the spade; and in others they use the spade in cultivating potatoes, and the plough only for corn. Yet potatoes, oats, and on the sea-coast barley, are sown to a considerable extent, and also flax. Wheat is cultivated only in particular spots, and chiefly by proprietors, a few of whom have also introduced turnips, peas, beans, rape, and cabbage. There is some excellent grazing land for cattle in the barony of Tyrrawley, and good sheep pastures in Kilnain. Some graziers hold 5000 Irish acres. The English long-horned cattle, which were imported by the principal proprietors, have greatly improved the native breed.

The habitations of the labourers, or cottars, are in general very wretched, and shared by them with their cow and pig.

7885. LEITRIM. 407,260 acres, one half bog, waste, and water, and the remainder dark fertile soil, incumbent on limestone. (*M'Parlan's Survey of Leitrim, 1802. Wakefield. Sup. Encyc. Brit. Edin. Gaz. 1827.*)

Coal, ironstone, lead, copper, &c. are found, but not worked.

Estates large, and nearly all the great proprietors are absentees. The leases are commonly for three lives or thirty-one years. Agriculture is here in a very low state. The tillage farms are small, seldom exceeding fifty or sixty acres, and these are almost always occupied in common by a number of tenants. The plough is very little used. The most common implement is the loy, a kind of spade eighteen inches long, about four inches broad at the bottom, and five or six inches at the top, where it is furnished with a wooden handle about five feet long. The first two crops are potatoes, which are followed by flax, and then oats for one or more years. Clovers and other green crops are unknown to the practice of the tenantry. The county raises grain and potatoes sufficient for its own consumption, but exports very little of either. Its cattle have been much improved by the introduction of English breeds, to which some of those now bred and reared in it are said to be not inferior. There are no considerable dairies, yet a good deal of

butter is made throughout the district. The sheep are of the native race, small, and but few in number.

About the beginning of the eighteenth century, Leitrim is said to have been almost a continued forest. There is now little wood in it, and no considerable plantations. The proprietors, however, have of late paid some attention to this method of improvement, and several large nurseries have been established for the sale of forest and other trees.

There are several bleach-fields, and some coarse potteries; and a number of people are employed in weaving. But the linen made here, as well as the coarse woollen goods, is chiefly for the use of the inhabitants themselves. The houses of the lower classes are of the worst description; even the more recently erected farm buildings, including a little barn and cow-house, do not cost more than ten or twelve pounds. Turf is their only fuel, and potatoes and oaten bread the chief articles of food, meat being used on extraordinary occasions only.

7886. SLIGO. 597,060 acres, a third part bogs, mountains, and waters, and the remainder fit for tillage or grazing. (*M'Parlan's Survey of Sligo*, 1802. *Wakefield. Sup. Encyc. Brit. Edin. Gaz.* 1827.)

The soil is generally of a light, sandy, gravelly loam, or moory; in some parts the lands are rich and fertile, but the subsoil of a considerable tract is a grey flag, provincially leaclea, unfavourable to vegetation. Numerous streams and lakes; the wooded islands and scenery around Lough Gill very striking. On the Sligo and Moy, considerable salmon fisheries; trouts abound, and white fish on the shores.

Estates of almost every size. A few are worth from 500*l.* to 9000*l.* a year; yet a considerable proportion of the county is divided into small properties. The principal proprietors are absentees. Farms vary in size, from three Irish acres to 500; the larger farms, however, are not held by individual tenants, but in partnership. The leases are for thirty-one years and three lives, and, in some instances, for sixty-one years and three lives; being, in general, longer here than in other parts of Ireland. Tillage-farming is still in a very backward state. The plough is worked by three or four horses yoked abreast,

directed by a man who walks backward before them. Oats, barley, and potatoes are the principal crops. Of the two former, a great proportion is consumed in illicit distillation, which, within these few years, was carried on in almost every part of the county. It was to the sale of these spirits that many of the small tenants looked as the means of paying their rents. In some parts, both cattle and sheep are kept in considerable numbers, and a great deal of butter is exported from the town of Sligo; but the land occupied in this way bears but a small proportion to the whole; to grow corn, being the principal object. Limestone and limestone-gravel, which are in abundance in most places, are in general use as manures; also marl, and, on the coast, sea-weeds. Among the hills are several large lakes, and abundance of rivers.

The *manufactures* for export are linen, salt, and kelp. The cabins, food, fuel, and clothing of the lower classes, seem to be as uncomfortable as in any of the Irish counties.

7887. CAVAN. 499,957 acres, almost entirely covered with hills; the surface, soil, and climate, being alike bleak and uncomfortable. There are no fewer than 91 bogs, occupying 17,000 acres. (*Coote's Statistical Account. Wakefield. Sup. Encyc. Brit. Edin. Gaz.* 1827.)

Near Farnham, the appearance of the country is favourable; the lakes there are picturesque, and communicate with each other by a river. The fossils are various, but neglected.

Two *estates* are of 50,000 and 26,000 acres; besides these there are none of very great extent. Nearly the whole of the land is under tillage, but the agriculture in every respect is very bad. The size of the farms is from 50 to 100 acres; but these are generally subdivided into farms of from two to twenty acres, which are re-let to the manufacturers or "cottars," who pay a high rent for them, by means of their other employments. Their principal object is to raise a sufficient quantity of oats and potatoes to feed their families, and of flax to give employment to the women and children. Most of the land is dug with the spade, and trenched: where the plough is used, they put three or four horses to it; and when Young visited the county, he found that all over it the horses were yoked to the ploughs and harrows by the tail; that practice, however, is now disused. Almost the only grain sown is oats, which are reckoned to be in the proportion of seventy to one, to all other grain; there is scarcely any wheat. In 1809, there were 4500 acres of flax, from which 6500 bushels of seed were saved.

Though the very tops of the hills are tilled, yet it does not appear that this county produces more grain than is necessary for its home consumption; nor has the bounty on the inland carriage of corn to Dublin, increased the very trifling quantity brought to that market. From the coldness and moisture of the climate, all the corn of Cavan is obliged to be kiln-dried.

The *stock-farms* generally consist of about 100 or 150 acres, the farmers buy young cattle, and sell them again without fattening; a few, however, fatten bullocks or sheep, but the latter are very poor. There are very few dairy farms, though from these, as they are in the richest parts of the county, a good deal of butter is sent. Many pigs are kept by the cottars; and near all the cabins are to be seen goats tethered to the tops of the banks, or "ditches," as they are here called, which divide the fields.

Cavan was formerly celebrated for its extensive woods, and trees of an immense size; but at present it is, in general, bare of timber, except near Kilmore, Farnham, and a few other places. Wakefield remarks, that the ash is confined to parts of the county, and to Tyrone and Fermanagh.

The *linen manufacture* is the staple.

7888. FERMANAGH. 450,000 acres, in great part covered by water, and much of the rest of the surface rugged and mountainous, but better wooded than other parts of Ireland. (*Wakefield. Sup. Encyc. Brit. Edin. Gaz.* 1827.)

The *ash* grows in the hedge-rows; beeches come to a large size, and also the yew, near Lough Erne; and fir, oak, and yew are found in the bogs. The grand feature in the natural scenery of this county is Lough Erne, which occupies about one eighth of the surface, and contains more than three hundred islands. It contains most of the fish that are found in other fresh water lakes, and is noted for its salmon and eels, particularly the latter. Four of the eel weirs near the falls of Beeleck afford a rent of 100*l.* each.

Estates are large; three proprietors mentioned by Wakefield have 13,000*l.* a year each, and other three from 6000*l.* to 7000*l.* The leases are most commonly for twenty-one years and a life. In the northern part of the county, the farms are larger and

more productive than in most other parts of Ulster. Oats, barley, potatoes, and flax are the principal crops: very little wheat, clover, or turnips being cultivated, except in small patches near the towns. The high grounds are chiefly occupied in rearing cattle, and much of the better pastures with dairy stock. There are no large flocks of sheep, and their breed of this animal is of a very inferior description. Agriculture is in a very backward state, and as lately as the year 1808 the peasantry were accustomed to fasten their ploughs to the horses' tails.

Linen, seven eighths wide, manufactured to some extent; and there are several bleach-fields, which finish for sale the linens sent to England. Illicit distillation is said to be very general.

7889. MONAGHAN. 288,500 acres of low grounds, with detached hills, and a considerable space occupied by bogs and small lakes. (*Coote's Survey of Monaghan*, 1801. *Wakefield. Sup. Encyc. Brit. Edin. Gaz.* 1827.)

There are a few large *estates*, but the greater part small ones, many of which do not even yield a free income equal to the ordinary wages of labour. A few years ago, there were only 172 freeholders of 50*l.* and upwards, out of nearly 6000; most of the considerable proprietors are absentees; and very little of the landed property is in the hands of Catholics.

Farms were so small a few years ago, as not to average ten Irish acres over the whole county; and the management, as might be expected, was exceedingly unskilful and unproductive. The spade was used much more than the plough: the latter being an implement which, with the team required to work it, and the party to attend and direct it, could be brought into action only by the united efforts of several tenants. The

general term of leases is twenty-one years and a life, or sometimes three lives. The principal crops are oats, potatoes, and flax, with wheat and barley in a small proportion; these last, however, extend over a much greater tract now than they did a few years ago. They make a good deal of butter, but there are no large dairies. Goats are in greater numbers than sheep, which is of itself a sufficient proof of the low state of its agriculture.

The *linen manufacture* is said to have averaged, twenty years ago, about 200,000*l.* a year. It is carried on by the greater portion of the inhabitants of both sexes, all the small farmers being also weavers.

7890. TYRONE. 813,440 acres in great part mountainous, and containing, among other mountains, Bessy Bell and Mary Gray, celebrated in song. The territorial value of this inland and northern district is much inferior to that of most others. (*M'Evoy's Survey of Tyrone*, 1802. *Sup. Encyc. Brit.*)

Various valuable *fossils* found, but not worked: the best pottery in Ireland, near Dungannon. Lough Neagh, the largest lake in Ireland, covers 110,000 acres, but is not celebrated for its scenery.

Estates are of very great extent, many of them worth from 5000*l.* to 7000*l.* a year, and the productive or arable land divided into very small farms, not often exceeding twenty Irish acres. The chief proprietors are the Marquess of Abercorn, Lords Belmore, Northland, and Mountjoy. The leases are for various periods, thirty-one years and three lives, three lives, and twenty-one years and a life. On some estates the land passes through the hands of middlemen, in portions of various sizes, till it reaches the actual cultivator, for the most part, in very minute subdivisions. It is customary for several persons to be concerned in one townland, which is held in what is called rundale; the cultivated land being divided into shares, which are changed every year, and the cattle pasturing in common—a system utterly inconsistent with profitable occupation, or the amelioration of the soil and live stock. The cattle

and sheep are accordingly of a very inferior description; and the latter, which are not numerous, may frequently be seen tethered upon the small patches of herbage which are interspersed among the shares of these partnership concerns. The tillage land, too, is more frequently stirred with the spade than the plough; and where a plough is used, the team, consisting of horses, bullocks, and even milch cows, must be supplied by the contributions of three or four neighbours, who unite their means for the purpose, each attending the operation, lest his poor animal should have more than his proper share of the labour. Potatoes, oats, and flax are the principal crops.

The *linen manufacture* is carried on to a great extent, and the potteries and collieries employ a considerable number of hands; to which we may add illicit distillation, which prevails throughout the north-western counties of Ireland. The food of the lower classes is oatmeal and potatoes; wheaten bread and butcher-meat never being used but on extraordinary occasions.

7891. DONEGAL. 1,100,000 acres of ragged, boggy, and mountainous surface, with a cold, wet climate, and neither woods nor plantations to shelter from the blast. (*M'Parlan's Survey of Donegal*, 1802. *Wakefield. Sup. Encyc. Brit.*)

Landed property is in few hands.

Agriculture is in a very backward state in Donegal. The use of the plough is confined to a small proportion of the cultivated land, and is generally of a bad construction; spade labour is preferred in most places. Barley is the chief grain crop, and it is almost all used in distillation; oats are only grown for home consumption, and wheat is confined to a few favourite spots. There are only two flour mills in the county. The culture of flax is considerable in the barony of Raphoe, and is extending even in the mountain districts. Potatoes are cultivated every where; turnips, clovers, and other green crops, are almost unknown among the tenantry. Village or partnership farms still abound, but farms now begin to be let to individuals as separate holdings. In the low country they are from ten to fifty acres in extent, and from 40 to 500 in the mountains. The fences are commonly nothing better than ditches, with banks of turf or clay, so that the cattle require to be herded while

the crops are growing; and in many parts they are allowed to graze promiscuously as soon as the crops are removed. Sea-weed and shell-sand are used as manures, but very little limestone, or limestone gravel. The practice of paring and burning, so common in many parts of Ireland, is seldom resorted to in this county. Leases are granted for twenty-one years and a life.

The *staple manufacture* of Donegal is linen. Women are much employed in knitting stockings. Kelp is prepared along the north-west coast; and, during the fishing season, three or four salt-pans used to be kept in full work. But whisky, says Dr. M'Parlan, particularly in the mountain region, and all around the coast, is the chief manufacture. "It is by running their barley into this beverage that they provide for one half-year's rent. This is, therefore, a tax raised by the rich on the morals and industry of the poor."

7892. LONDONDERRY. 510,720 acres, generally mountainous, fertile and beautiful in the valleys, and containing every variety of soil. (*Sampson's Survey of Londonderry, 1802. Wakefield. Sup. Encyc. Brit. Edin. Gaz. 1827.*)

Landed property. With the exception of lands belonging to the church, and the towns of Londonderry and Coleraine, and certain portions reserved by the crown to be afterwards erected into freeholds, the whole of Londonderry was granted by James I. to the twelve companies or guilds of London. The estates are, therefore, held from these companies, either in perpetuity, or on determinable leases. The principal proprietors or leaseholders are Lords Waterford and Londonderry, Conolly, Ogilby, and the families of Beresford and Ponsonby.

The average *size of farms* is from five to twenty Irish acres, or at a medium little more than fifteen acres English. Whole districts are subdivided into patches of seven or eight acres, but in a few situations there are farms of upwards of 300 acres. The leases, though most commonly for twenty-one years and one life, are frequently for such very short periods, as to be a great drawback upon agriculture. The practice of letting land upon short leases is, however, only recently introduced.

The *principal crops* are potatoes, barley, oats, and flax. Wheat is not in general cultivation. Turnips are very rare, and sown grasses and clovers far from being common. No uniform rotation of crops is recognised in practice, but it is usual to take two crops of oats successively, and sometimes flax the year following. Fiorin is the predominating plant in the meadows, where it grows spontaneously with great luxuriance. The live stock presents nothing worthy of particular notice. Grazing grounds are not extensive, and there are few dairies. On the east side of the Bawn there are two extensive rabbit-warrens.

The *principal manufacture* is linen; the value exceeds half a million sterling, besides brown or unbleached linens.

Granite, freestone, sandstone, and those beautiful rock crystals, which, when cut, are termed Irish diamonds, are found in various parts. Iron, copper, lead, and coal have also been found.

7893. ARMAGH. 293,871 acres of varied and rather interesting surface of mountain, plain, and bog; with rivers, streams, and lakes, and a climate mild for the latitude; 244,000 acres are esteemed fit for cultivation. The celebrated George Ensor is a native of this county, and resides on his own estate at Loughgall, near Armagh. (*Coote's Survey of Armagh, 1804. Wakefield. Sup. Encyc. Brit. Edin. Gaz. 1827.*)

Marble of an excellent quality, and of great beauty, is wrought in Armagh. The chain of mountains called the Fews, of which Sleive Gullian is the highest, present many highly sublime and picturesque scenes.

Estates in this county are not large, there being only seven or eight proprietors who possess them of the annual value of from 6000*l.* to 10,000*l.* The farms also are small, being commonly from five to twenty acres, and seldom exceeding forty or fifty.

Neither the arable nor the pasture *husbandry* of this county present much that is worthy of notice. Potatoes, flax, and oats are the chief produce of the arable districts; and those are cultivated in a very rude and inferior manner, in consequence of the ignorance of the farmers, and their want of capital.

There are no extensive dairy farms, nor are there any farmers exclusively in this branch of husbandry; nevertheless a considerable quantity of butter is made here. One hundred weight

per cow is considered as the average produce. The proportion of the milch cows to the size of the farms is, on small farms under five acres, one cow; on farms exceeding five, and under ten acres, perhaps two cows, seldom more. A considerable number of cattle are reared. From the low country they are sent to the mountain farms, and frequently afterwards sold in the Scotch market. They are in general of a small stunted breed. The native sheep are an awkward breed; the wool coarse, and in small quantity; very little of it is exposed to sale, there being hardly sufficient for domestic use. Goats, swine, and poultry abound. Wild geese, swans, wild ducks, and several other species of aquatic birds, are indigenous to the lakes and rivers. Formerly bees were much attended to, but at present they are neglected.

The *roads* in general are bad; and, what is extraordinary, the turnpikes are the worst, and the cross roads the best.

The *principal manufacture* is that of linen.

7894. DOWN. 559,995 acres, of which one eighth are mountainous and waste, the remainder hilly and productive, cultivated by small manufacturers, and embellished by plantations, bleaching grounds, and neat white-washed habitations. The climate is variable, but not subject to extremes. (*Dubourdieu's Survey of Down, 1802. Sup. Encyc. Brit. Edin. Gaz. 1827.*)

Landed property. There are some large estates, though in general it is much divided, and has all the different gradations, from the most opulent nobleman to the tenant in perpetuity who farms his own land. Most of it is freehold. The rental was above the average rental of the best counties in Scotland, as returned to the commissioners of the property-tax in 1811.

The *farms* may be divided into two kinds: the first, such as are possessed by farmers who have recourse to no other branch of industry; the second, such as are held by weavers and other tradesmen. The former run from twenty to fifty, and, in some instances, so far as 100 acres; the latter are of every size, from one to twenty acres. It has been remarked that the divisions of the farms are so minute, as to be extremely prejudicial to agriculture. The rent is always paid in money; personal services are never extracted. Some leases are for lives and years, others for lives alone. Fences consist chiefly of a ditch and bank, without quicks of any kind, or sometimes with a few plants of furze stuck into the face of the bank; but dry stone walls are frequent in the stony mountainous parts. Great improvement has been made in its agriculture within these twenty years. Threshing-mills and two-horse ploughs have been introduced; but it cannot be said that a good system prevails generally, which the small size of the farms, indeed, renders impracticable. A regular rotation is rarely followed in the crops; fallows, clovers, and turnips, are upon a very small scale; and from the greater part of the arable land, it is still the practice to take crops of grain in succession, only partially interrupted by potatoes, flax, and peas. Oats, the principal grain, are grown on all soils; barley is usually sown after potatoes, and also wheat to some extent on the coast. Of flax they sow four bushels an Irish acre, and the medium produce is fifty stones. Rye and peas occupy but a small space. Lime, marl, shelly-sand, and sea-weed, are used as manures. Paring and burning are confined to the mountains.

There are *extensive meadows* on the banks of the Bann and the Laggan; but the soil, except on the mountains, is thought to be better adapted to tillage than pasture. A good many beasts are fatted, but cows are the prevailing stock, kept in small numbers on every farm. They are long-horned, thin in the sides, and deep in the belly, but yield much milk when well fed, and each of them from 60 to as much as 120 pounds of butter in the year, or about two thirds of the medium produce of the butter dairies of England. Numerous horses are reared in the mountainous districts; and goats, furnishing the inhabitants with milk are seen around all the cottages. Sheep, in flocks of any size, are confined to the mountain districts. They are very small, many of them, when fat, not weighing more than seven or eight pounds a quarter. On the low ground there are a few, seldom exceeding half a score, on almost every farm. A great number of hogs are fattened; many of them bred in the county, but not a few brought from the west of Ireland. The dry hills of this county, covered with heath and odoriferous herbs, are well adapted to bees, but the number of hives has greatly decreased within these twenty years.

The *principal manufacture* is linen, which is carried on in all its branches. Kelp is also an article of commerce.

Copper and lead are found within the precincts of Down, and marine exuvia among the hills at a great distance from the sea. There is also black marble susceptible of a high degree of polish, slate, coal, freestone, and crystals. Natural woods are seen in some parts, but plantations are scarce; there are a good many orchards, a small one being attached to almost every cottage in the bleaching districts on the low grounds. Bleaching is conducted on a considerable scale upon the banks of the rivers; and vitriolic acid is made in several of the towns. Fish abound on the coast; but the inhabitants of Down derive little benefit from the bounty of nature in this particular.

7895. ANTRIM. 622,059 acres; on the east and north mountainous, destitute of plantations, and abounding in bogs; the other parts more level and fruitful, and the climate drier than in some other counties. (*Newenham's Statistical Survey. Wakefield. Dubourdieu's Survey of Antrim, 1812. Sup. Encyc. Brit.*)

Minerals. Besides basalt, limestone, gypsum, coals, fossil-wood, or wood-coal, sandstone, &c. are found. The fossil-wood, or wood-coal, in most places, is covered with columns of basalt, and is curious as explanatory of the origin of coal. Notwithstanding the compressed state in which it is found, the bark and knots are quite distinct, and the rings denoting the annual growth of the wood may be counted. In some instances the roots of the trees may be traced. Of the only two coal mines which are wrought in the province of Ulster, there is one in Antrim, at Bally Castle. The coals are bituminous, and of a bad quality; a great part of them are exported.

Landed Property. Estates are in general freehold, being either immediate grants from the Crown, or held under those grants. The exceptions are the properties under the see of Connor. Some of the estates are very large. The Marquess of Hertford and the Antrim family possess the fee of the major part of the county. The former has 64,000 *green acres*; that is, land capable of tillage, and independently of bog and mountain. Most of the Antrim estate is let on perpetuity, in farms worth 2000*l.* or 3000*l.* per annum. The other great proprietors are the Marquess of Donegal, Lord Templeton, and Lord O'Neil. The estate of Lord Templeton, however, is only leasehold under the Marquess of Donegal, who lets his land for sixty-one years and a life, but renews at the end of a few years for a price.

The *farms* are in general very small. The principal feature in the tillage system is the potato fallow. The small size of the farms, and, in some places, the rockiness of the soil, precludes the use of the ordinary means of culture, and therefore a part

of the land is dug with the spade. The quantity of potato-land is regulated by the quantity of manure that can be collected. After potatoes, flax is sown, and the quantity of flax ground is regulated by the ability to purchase the seed. A crop of oats finishes the regular rotation. When the ground is exhausted, it is turned to rest, that is, it is suffered to lie till it is covered with natural grass. Such is the most general plan of husbandry pursued in Antrim. In those parts where the farms are too large for the spade culture, the land is ploughed by three or four neighbours uniting their strength; one supplying the plough, and the others bringing a horse, bullock, or even a milch cow. Wheat is a plant of very modern introduction in Antrim, and very little of it is sown.

The most important crop is flax.

The cattle consist chiefly of milch cows, belonging to small occupiers, of a small stunted breed. Sheep are very little attended to; and the few that are kept are of a very inferior kind. Goats are numerous in the mountainous parts of the county. Pigs also are kept in great numbers.

This county by no means abounds with wood; nor are fruit-trees cultivated in great abundance, or with very much success. Of the apple, however, several new and valuable varieties have lately been introduced, and advantageously cultivated.

Antrim has long been distinguished for its *linen manufacture*; but latterly the manufacture of cotton has, in some measure, supplanted it, especially in the vicinity of Belfast.

There is a considerable salmon-fishing on the coast.

The stupendous assemblage of basaltic columns, called "the Giant's Causeway," lies on the maritime confines of Antrim.

CHAP. IV.

Literature and Bibliography of Agriculture.

7896. *The first books on agriculture* were written by the Greeks before the Christian æra, and by the Romans about the commencement of that period. Hesiod is the only writer of the former people exclusively devoted to husbandry: the earliest Roman author is Cato; and the latest, Palladius, in the fourth century A.D. The works of these and the other agricultural writers of antiquity have been already enumerated (25. and 44.), and the most interesting have lately been re-translated (7110. anno 1800).

7897. *In the dark ages* few books were written except on religion. The first author that appeared on the revival of the arts was Crescentius in Italy, in the fifteenth century; and soon after, in the sixteenth, Fitzherbert in England, Olivier des Serres in France, Heresbach in Germany, and Herrera in Spain. Since these works appeared, many others have been published in every country in Europe, especially in England, France, and Germany. Though our business is chiefly with the works which have appeared in Britain: yet we shall, after enumerating the chief of them, notice also what has been done in other countries; many foreign works, especially of France, Germany, and Italy, being familiar, either in the original or by translations, to the reading agriculturists of this country. All the works of importance, whether foreign or domestic, published or to be published since 1825, will be found noticed or reviewed in the *Gardener's Magazine*, commenced in that year, and in continuation,

SECT. I. *Bibliography of British Agriculture.*

7898. *A general view of the literature of British agriculture* having been already given (801.), we have here only to supply the bibliographical enumeration confirmatory of that view. Of agricultural books very few at the present day are worth reading for their scientific information; they are chiefly to be considered as historical documents of the progress of opinions and practices; and this is the reason we have arranged them in the order of their appearance, instead of classing them according to the subjects treated of. Those who wish to see them so classed will be amply gratified by Watts's *Bibliographia Britannica*. In our list we have omitted many works on subjects belonging to political agriculture, as the corn laws, tithes, poor-rates, &c.; and also most of those on veterinary surgery, horsemanship, bees, hunting, planting, &c., as not strictly belonging to the subject, and as being for the greater part, those on the veterinary art in particular, worse than useless. In short, the improvements in chemistry, animal and vegetable physiology, and the comparatively clear views of political economy which have taken place chiefly since the commencement of the present century, have rendered most books on agriculture, whether political or professional, not published within the last ten years, of very little value, and a number of them more injurious than useful. This second edition of British authors on agriculture is considerably reduced, in order to render it more select; and, through the obliging disposition of Mr. Forsyth, perhaps the only man in existence thoroughly acquainted with the bibliography of British agriculture and gardening, it is rendered much more accurate.

1500. *Groshede*, Bishop of Lincoln.

Here begyneth a Treatyse of Husbandry, which Mayster Groshede, sotyne Bysshop of Lyncolne, made and translated out of Frensshe into Englyshe. Lond. 4to.

1523. *Fitzherbert*, or *Fitzherbarde*, Sir Anthony, a very learned lawyer, and also known as the father of English husbandry, was born at Norbury, in Derbyshire, and died there in 1538. He was made judge of the Common Pleas in the 15th of Henry VIII., and wrote several books on law.

1. The Book of Husbandry, very profitable and necessary for all persons. Lond. 1523, 4to; 1532, 16mo.

2. Surveying. Lond. 1523, 4to; 1539, 16mo.

3. De Extenta Maneril. Lond. 1539.

1538. *Benese*, Sir Richard, Canon of Marton Abbey, near London.

The Manner of Measurynge all Maner of Land. 16mo.

1557. *Tusser*, Thomas, styled the British Varro, was born near Witham, in Essex, 1515; received a liberal education at Eton School, and at Trinity Hall, Cambridge; lived many years as a farmer in Suffolk, and afterwards removed to London, and published his experience in agriculture and gardening. He died in 1580.

1. A hundreth good Pointes of Husbandrie. Lond. 4to.

2. Five Hundreth Points of Good Husbandry, suited to as many of Good Huswifere; with divers approved lessons concerning Hops and Gardening. Lond. 4to. 1573.

1581. *Mascall*, Leonard, author of a work on sowing, planting, and grafting trees, &c. 1572.

1. The Husbandlye Ordering and Government of Poultrie, &c. Lond. 8vo.

2. The First Book of Cattel, &c. Lond. 1587. 4to.

3. A Booke of Fishing with Hooke and Line, and all other Instruments thereunto belonging: another of Sundrie Engines

and Trappes to take Polecats, Buzards, Rats, Mice, and all other kinds of Vermin and Beasts whatsoever; moste profitable for all Warriners, and suche as delight in this kinde of sporte and pastime. Lond. 1590. 4to.

1601. *Anon.*

God speede the Plough. Lond. 4to.

1601. *Plat, Hugh.*

The new and admirable Arte of setting of Come, with all the necessarie Tooles; and other Circumstances belonging to the same. Lond. 4to.

1610. *Vaughan, Rowland.*

Most approved and long experienced Water Works: containing the Manner of Summer and Winter drowning of Meadow and Pasture by the Advantage of the least River, Brooke, Fount, or Water Trill adjacent. Lond. 4to.

1613. *Markham, Gervase, Jarvise, or Gervas.* An author who wrote on a great variety of subjects during the reigns of James I. and Charles I., and died about 1685. He appears, says Harte (*Essays*, ii. 32.) to be the first Englishman who deserves to be called a hackney writer.

1. The English Husbandman; 2 Parts. Lond. 1613. 4to.

2. Farewell to Husbandry. Lond. 1620. 4to.

3. Cheap and Good Husbandry, for the well ordering of all Beasts and Fowls, &c. Lond. 1616, 1631. 4to.

4. Enrichment of the Weald of Kent, &c. Lond. 1620, 1631. 4to.

1616. *Stevens and Liebault.*

Maison Rustique, or the Country Farm; translated into English by Richard Surflet, Practitioner in Physicke, newly reviewed, &c.; and the Husbandrie of France, Italy, and Spaine reconciled and made to agree with any here in England. By Gervase Markham. Lond. fol.

1635. *Calthorpe, Charles.*

The Relation between a Lord of a Manor and the Copyholder, his Tenant. Lond. 4to.

1639. *Plattes, Gabriel,* author of some tracts on Gardening; a poor man but a useful writer. Harte says, he had a bold adventurous cast of mind, and preferred the faulty sublime to faulty mediocrity. As great a genius as he was, he was allowed to drop down dead in London streets with hunger; nor had he a shirt upon his back when he died. He bequeathed his papers to Hartlib, who seems to have published but few of them.

1. Discovery of infinite Treasure, hidden since the World's beginning, in the Way of Husbandry. 4to.

2. Discoverie of Subterranean Treasure, viz. all manner of Mines and Minerals, from the Gold to the Coal, &c., with directions for the finding them. Lond. 1653. 4to.

3. Observations and Improvements in Husbandry, with Twenty Experiments. Lond. 1653. 4to.

1642. *Vermuyden, Sir C.,* a native of Holland, and a colonel in Cromwell's army.

Discourse touching the Dreyning the great Fenns lying within the several Counties of Lincolne, Northampton, Huntingdon, Norfolk, Suffolke, Cambridge, and the Isle of Ely. 4to.

1645. *Weston, Sir Richard.*

Discourse of Husbandry used in Brabant and Flanders, shewing the wonderful Improvements of Land there. Lond. 4to.

1649. *Blieth, Walter,* an officer in Cromwell's army, who, with other English gentlemen holding commissions at that time, was eminently useful in introducing improvements into Ireland and Scotland.

1. The English Improver, or a new Survey of Husbandry, discovering to the kingdom that some Land, both Arable and Pasture, may be advanced Double and Treble, and other, Five and Ten fold. Lond. 4to.

2. The English Improver improved; or the Survey of Husbandry surveyed. Lond. 1652. 4to. 3d Edit.

1651. *Hartlib, Samuel,* an ingenious writer on agriculture, and author of several theological tracts. He was the son of a Polish merchant, and came to England, according to Weston, about 1640; but the time when he died is unknown. He was a great promoter of husbandry during the times of the commonwealth, and was much esteemed by all ingenious men in those days. Milton addressed to him his treatise on education, and Sir William Petty inscribed two letters to him on the same subject. Cromwell allowed him a pension of 100*l.* a year.

1. Legacy; or, an Enlargement on the Discourse of Husbandry used in Brabant and Flanders. This work is said in the *Census Literaria* to be written by Robert Child. With an Appendix. 1651. 4to. Lond.

2. Appendix to the Legacy, relating more particularly to the Husbandry and Natural History of Ireland. Lond. 1652. 4to.

3. Essay on the Advancement of Husbandry and Learning, with propositions for erecting a College of Husbandry. Lond. 1651. 4to.

4. The Reformed Husbandman; or, a brief Treatise of the Errors, Defects, and Inconvenience of our English Husbandry, in ploughing and sowing for Corn; with the Reasons and general Remedies, and a large yet faithful Offer or Undertaking for the Benefit of them that will joy in this good and public Work. Lond. 1651. 4to.

5. Design for Plenty, by a Universal Planting of Trees; tendered by some well-wishers to the Public. Lond. 1652. 4to.

6. Discovery for Division or Setting out of Land in England and Ireland. Lond. 1653. 4to.

7. The Complete Husbandman; or, a Discourse of Husbandry, both Foreign and Domestic. And a particular Discourse of the Natural History of Husbandry in Ireland. Lond. 1659. 4to.

1659. *Speed, Adam.*

1. Adam out of Eden; or, an Abstract of divers excellent

Experiments, touching the Advancement of Agriculture. Lond. 12mo.

2. Husbandman, Farmer, and Grazier's Complete Instructor. Lond. 1697. 12mo.

1662. *Dugdale, William.*

History of the embanking and drayning of divers Fens and Marshes, both in forrain parts and in this kingdom. Lond. fol. 2d edit. pt. 1772. Revised by C. N. Cole, Esq.

1664. *Forster, John.*

England's Happiness increased; or a sure and easie Method against all succeeding dear Years, by a Plantation of the Roots called Potatoes, &c. Lond. 4to.

1665. *Dodson, Colonel William.*

The Design for the perfect Draining of the great Level of the Fen, called Bedford Level, with Maps, &c. Lond. 4to.

1669. *Worlidge, John,* gentleman, author of some works on gardening.

Systema Agricultura, &c. Lond. fol.

1670. *Smith, John, Gent.*

England's Improvement revived; plainly discovering the several Ways of improving the several Sorts of waste and barren Grounds, and of enriching all Earths; with the natural Quality of all Lands, and the several Seeds and Plants which naturally thrive therein, observed; together with the manner of planting all Sorts of Timber Trees and Underwoods; experienced in 30 Years' Practice; in 6 Books. Lond. 4to. 1673.

1681. *Houghton, John, F.R.S.*

A Collection of Letters for the Improvement of Husbandry and Trade. Lond. 4to. Again in 1728, 4 vols. 8vo, revised by R. Bradley.

1683. *Lister, Martin, M.D.,* an eminent physician and natural philosopher; was born in Buckinghamshire about 1638; practised in London; died 1711-12. He wrote various works.

Of Plants which may be usefully cultivated for Grass or Hay. 1696. (*Phil. Trans. N. Abr.* iv. 156.)

1685. *Moore, Sir Jonas, Knight, F.R.S.,* a very respectable mathematician, and surveyor-general of his majesty's ordnance, was born in Lancashire, 1617; died 1679.

1. History or Narrative of the great Level of the Fens called Bedford Level; with a large Map of the said Level, as drained, surveyed, and described. 8vo.

2. England's Interest; or the Gentleman and Farmer's Friend. Lond. 1695. 8vo.

1694. *Floyd, Edward.*

1. Account of Locusts in Wales. (*Phil. Trans. Abr.* iii. p. 617.)

2. On the spontaneous Combustion of several Hay-stacks, &c. (*Ib.* p. 618.)

1697. *Donaldson, James,* a native of Scotland, and one of the earliest and most useful writers on the agriculture of his country.

Husbandry Anatomised; or an Enquiry into the present manner of Tilling and Manuring the Ground in Scotland. Edin. 12mo.

1697. *Meager, Leonard,* author of *The English Gardener* and other works.

The Mystery of Husbandry. Lond. 12mo.

1700. *Nourse, Timothy, F.R.S.*

Campania Felix; or a Discourse of the Benefits and Improvements of Husbandry. Lond. 8vo.

1707. *Mortimer, John,* author of some tracts on religious education. His works on husbandry were translated into Swedish, and published in Stockholm, in 1727.

The whole Art of Husbandry, in the way of Managing and Improving Land. Lond. 8vo.

1717. *Laurence, Edward,* brother to John Laurence, a clergyman, author of a work on gardening. (See A. D. 1726.)

The Duty of a Steward to his Lord; with an Appendix on Farming. Lond. 1727. 4to.

1721. *Bradley, Richard, F.R.S.,* and Professor of Botany in the University of Cambridge; a most voluminous writer on gardening, botany, &c.; died 1732. (*Encyc. of Gard.* p. 1102.)

1. Philosophical Treatise of Husbandry and Gardening. Lond. 4to.

2. The Country Gentleman, and Farmer's Monthly Director. Lond. 1721. 8vo.

3. Experimental Husbandman and Gardener. Translated from the German of G. A. Agricola. Lond. 4to. 1726.

4. A Complete Body of Husbandry. Lond. 1727. 8vo.

5. The Weekly Miscellany for the Improvement of Husbandry, Arts, and Sciences. 21 Nos. 1727. 8vo.

6. The Science of Good Husbandry, or the Economy of Xenophon; translated from the Greek. Lond. 1727. 8vo.

7. The Riches of a Hop Garden explained, with the Observations of the most celebrated Hop Planters in Britain. Lond. 1729. 8vo.

1724. *Anon.*

A Treatise concerning the Manner of following Ground, raising of Grass Seeds, and training of Line and Hemp. Edin. 8vo. Plates.

1726. *Lawrence, John, M.A.,* author of *The Clergyman's Recreation*, a gardening work of use in its time; he died in Durham, 1732. (*Encyc. of Gard.* p. 1102.)

The New System of Agriculture; being a complete Body of Husbandry and Gardening in all the parts of them. Lond. fol.

1729. *Mackintosh, Borland.*

Essay on Ways and Means for Inclosing, Following, Planting, &c. Scotland, and that in sixteen Years at farthest. Edin. 8vo.

1730. *Richards, John.*

The Gentleman's Steward and Tenants of Manors instructed. Lond. 8vo.

1730. *Rye, George.*

Observations on Agriculture. Dub. 8vo.

1731. *Tull, Jethro*, was born in Oxfordshire; he was a barrister, and made the tour of Europe; after which he settled on his paternal estate, which he cultivated with so much attention as brought on a disorder in his breast. He then went abroad, and, on his return, fixed his residence on a farm in Berkshire, where he renewed his experiments in horse-hoeing husbandry: he died in 1740. His son, John Tull, was an officer in the army, but ruined himself by projects, and died in the Fleet in 1764. (*Gent. Mag.*) Mr. Tull's farm was "situated at a place called Prosperous (probably so called from his great success), in a tract of very indifferent land, lying on the north side of the Hampshire hills, near the borders of Wiltshire, but being itself in the county of Berks. It is, I believe, in the parish of Ink-pen. I visited it in the company of Mr. Budd of Newbury, who had visited it long before with Arthur Young, who, like me, visited it in the character of a pilgrim, and in honour of the memory of the real founder of every recent improvement that has been made in the agriculture of England." (*Cobbett's Treatise on Cobbett's Corn*, chap. vi.)

1. Specimen of a Work on Horse-hoeing Husbandry. Lond. 4to.

2. New Horse-hoeing Husbandry; or an Essay on the Principles of Tillage and Vegetation; wherein is shown a Method of introducing a sort of Vineyard Culture into the Corn Fields, in order to increase their Product, and diminish the common Expense by the use of Instruments, described in Cuts. 1733. fol.

3. Supplement to the New Horse-hoeing, &c. Lond. 1739.

1732. *Ellis, William*, a farmer at Little Gaddesdon, near Hemel Hempstead, in Hertfordshire.

1. The Modern Husbandman; or, Practice of Farming. Lond. 1744. 8 vols. 8vo.

2. The Country Housewife's Family Companion. Lond. 1750. 8vo.

3. The Complete Planter and Cyderist. Lond. 1757. 8vo.

4. Ellis's Husbandry abridged and methodised. Lond. 1772. 2 vols. 8vo.

1737. *Phillips, Robert.*

Dissertation concerning the present State of the High Roads of England, especially those near London; wherein is proposed a New Method of repairing and maintaining them. Lond. 8vo.

1741. *Blackwell, Alexander*, M.D., a native of Aberdeenshire. Blackwell studied physic under Boerhaave at Leyden, took the degree of M. D., practised as a physician at Aberdeen, and afterwards at London, but meeting with no success, turned printer, and became bankrupt in 1734. About 1740 he went to Sweden, turned projector, and laid a scheme before his Swedish Majesty for draining the fens and marshes. He was suspected of being concerned in a plot with Count Tessin, and was beheaded August 9. 1748. His wife Elizabeth was the author of a curious herbal.

A new Method of Improving cold, wet, and barren Land, particularly clayey Grounds, &c. Lond. 8vo.

1743. *Maxwell, Robert*, an eminent Scotch improver.

1. Select Transactions of the Honourable Society of Improvers in the Knowledge of Agriculture in Scotland. Edinb. 1743. 8vo. Plates.

2. The Practical Husbandman. Edin. 8vo. 1757.

1744. *Claridge, John.*

The Shepherd of Banbury's Rules to know of the Change of the Weather. Lond. 8vo.

1757. *Home, Francis*, M.D., Professor of Materia Medica in the University of Edinburgh.

The Principles of Agriculture and Vegetation. Lond. 8vo.

1757. *Lister, Edward*, Esq., late of Crux-Easton, in Hampshire.

Observations on Husbandry. Lond. 4to, and 2 vols. 8vo.

1759. *Stillingsfiel, Benjamin*, grandson to the bishop of that name, and an ingenious naturalist and miscellaneous writer, interesting in agriculture as a promoter of the introduction of artificial grasses; was born about 1702; died 1771.

1. Miscellaneous Tracts relating to Natural History, Husbandry, and Physic. Translated from the Latin; with Notes. Lond. 8vo.

2. Calendar of Flora, Swedish and English, made in the year 1755. Lond. 8vo. 1761.

1759. *Mills, John*, F.R.S., author and translator of several works, and among others of Gyllenborg's *Natural and Chemical Elements of Agriculture*, an ingenious work for its time and country.

1. A Practical Treatise of Husbandry, collected by Duhamel, and also the most approved practice of the best English farmers. Lond. 4to.

2. A New and Complete System of Practical Husbandry. Lond. 1762-5. 5 vols. 8vo.

3. An Essay on the Weather; with Remarks on the Shepherd of Banbury's Rules for Judging of its Changes, and Directions for preserving Hives and Buildings from the fatal effects of Lightning. Lond. 1770. 8vo.

4. A Treatise on Cattle, &c. Lond. 1776. 8vo.

1760. *Hitt, Thomas*, gardener to Lord Manners,

at Bloxholme in Lincolnshire, and author of a meritorious work on fruit trees.

A Treatise of Husbandry; or the Improvement of dry and barren Lands. Lond. 8vo.

1761. *Mordant, John.*

The Complete Steward; or the Duty of a Steward to his Lord. Lond. 2 vols. 8vo.

1762. *Dickson, Adam*, A.M., minister of Dunse in Scotland. Considered a good classical scholar, and an excellent practical farmer. He died before *The Husbandry of the Ancients* was prepared for the press, which is the occasion of some defects in that work.

1. Treatise on Agriculture. Edin. 8vo. This is one of the best works on tillage that ever has appeared.

2. The Husbandry of the Ancients. Edin. 1778. 2 vols. 8vo.

1763. *Anon.*

Museum Rusticum et Commerciale; or Select Papers on Agriculture, Commerce, &c. Lond. 6 vols. 8vo.

1764. *Ladnar*, of Kroy, in Yorkshire.

The Farmer's New Guide. Lond. 8vo.

1764. *Randall, J.*, some time master of the academy at Heath, near Wakefield, Yorkshire.

1. The Semi-Virgilian Husbandry, deduced from various Experiments. Lond. 8vo.

2. Construction and extensive Use of a new-invented Seed Furrow Plough, suited to all Soils; of a Draining Plough; and of a Potato Drill Machine; with the Theory of a Common Plough; illustrated with 7 plates. Lond. 1764. 4to.

1765. *Fordyce, George*, M.D., F.R.S., a distinguished physician, and teacher of medicine in London; was born at Aberdeen, 1736; died 1802.

Elements of Agriculture and Vegetation. Edin. 8vo.

1766. *Homer, Henry*, an excellent classical scholar, was born in Warwickshire, 1752; died 1791.

1. An Essay on the Nature and Method of ascertaining the specific Shares of Proprietors upon the Inclosure of Common Fields. Lond. 8vo.

2. An Inquiry into the Means of Preserving and Improving the Public Roads of this kingdom. Oxf. 1767. 8vo.

1766. *Anon.*

The Complete Farmer: or a General Dictionary of Husbandry in all its branches, &c., by a Society of Gentlemen, Members of the Society of Arts, Manufactures, &c. London. Fol. Plates.

London, 1807, 2 vols. 4to, 5th edit. entitled The Complete Farmer, or General Dictionary of Agriculture and Husbandry, &c., wholly re-written and enlarged.

1767. *Young, Arthur*, F.R.S., an eminent agriculturist, secretary to the Board of Agriculture, was the son of Arthur Young, a prebendary of Canterbury, and author of *An Historical Dissertation of Corruptions in Religion*. He was born in 1741. He served his apprenticeship to a wine merchant; but on entering into the possession of his paternal estate, near Bury St. Edmunds, he became a farmer, and impoverished himself by experiments. After this he set up as a teacher of others, and in 1771 published a volume called *The Farmer's Calendar*, which was followed in 1784 by *The Annals of Agriculture*, in which he had Ralph Robinson, George III.'s farming bailiff, for a correspondent. Young also made excursions through the British islands and on the Continent, to collect information on subjects of rural economy. At length a Board of Agriculture was established, of which he was appointed secretary, with a salary of six hundred a year. He became blind some years before his death, which happened February 20. 1820. His works are numerous, and his travels amusing. (*Annual Biography.*)

1. The Farmer's Letters to the People of England, &c. Lond. 8vo.

2. The Farmer's Letters to the Landlords of Great Britain. Lond. 1771. 8vo.

3. A Six Weeks' Tour through the Southern Counties of England and Wales. Lond. 1768. 8vo.

4. Treatise on the Management of Hogs. Lond. 1769. 8vo.

5. A Six Months' Tour through the North of England. Lond. 1770. 4 vols. 8vo.

6. The Farmer's Guide in Hiring and Stocking Farms, &c. Lond. 1770. 2 vols. 8vo.

7. Rural Economy; or Essays on the Practical Part of Husbandry. Lond. 1770. 8vo.

8. A Course of Experimental Agriculture. Lond. 1770. 2 vols. 4to.

9. The Farmer's Tour through the East of England. Lond. 1770. 4 vols. 8vo.

10. Observations on the Present State of the Waste Lands in Great Britain. Lond. 1772. 8vo.

11. Tour in Ireland; with General Observations on the Present State of that Kingdom, made in 1776-7-8, and 9. Dub. 1780. 2 vols. 8vo.

12. An Essay on the Culture of Cole-seed for feeding Sheep and Cattle. 8vo.

13. Annals of Agriculture, and other useful Arts. Published in Nos. Bury St. Edmunds, 1790, 40 vols. 8vo.

14. Travels during the years 1787-8, and 9, undertaken more particularly with a View of ascertaining the Cultivation, Wealth, Resources, and National Prosperity of the Kingdom of France. Bury St. Edmunds, 1792. 4to. 2 vols.

15. General View of the Agriculture of the County of Suffolk; drawn up for the Board of Agriculture. Lond. 1797. 8vo.

16. General View of the Agriculture of the County of Lincoln; drawn up for the Board of Agriculture. Lond. 1799. 8vo.

17. An Enquiry into the Propriety of applying Wastes to the Maintenance and Support of the Poor. Lond. 1801. 8vo.

18. The Farmer's Kalendar, containing the Business necessary to be performed on the various kinds of Farms during every month of the year. Lond. 1800. 4 vols. 8vo.

19. Essay on Manures. Lond. 1804. 8vo.

20. General View of the Agriculture of Hertfordshire; drawn up for the Board of Agriculture. Lond. 1804. 8vo.

21. General View of the Agriculture of the County of Norfolk. Lond. 1804. 8vo.

22. General View of the Agriculture of the County of Essex. Lond. 1806. 2 vols. 8vo.

23. General Report on Inclosures. Lond. 1807. 8vo.

24. General View of the Agriculture of Oxfordshire. Lond. 1808. 8vo.

25. A General View of the Agriculture of the County of Sussex; drawn up for the Board of Agriculture. Lond. 1808. 8vo.

26. Advantages which have resulted from the Establishment of the Board of Agriculture. Lond. 1809. 8vo.

27. On the Husbandry of those celebrated British Farmers, Bakewell, Arbuthnot, and Duckett. Lond. 1811. 8vo.

1768. *Dossie, Robert, Esq.*
Memoirs of Agriculture, &c. Lond. 3 vols. 8vo.

1770. *Peters, Matthew.*
1. The Rational Farmer. Lond. 8vo.
2. Winter Riches. Lond. 1771. 8vo.

1770. *Comber, Thomas, LL.D.,* Rector of Buckworth and Morborne, in Huntingdonshire, died 1778.
1. Free and Candid Correspondence on the Farmer's Letters to the People of England, &c., with the Author and Arthur Young, Esq. Lond. 8vo.
2. Real Improvement in Agriculture, on the Principles of A. Young, Esq. To which is added, a Letter to Dr. Hunter of York, on the Kickets in Sheep. Lond. 1772. 8vo.

1770. *Hunter, Alexander, M.D., F.R.S.L. and E.* was born at Edinburgh, 1733; settled as a physician at Gainsborough, at Beverley, and finally at York, where he died, 1809.
1. Geographical Essays; in which the Food of Plants is particularly considered. Lond. 4 vols. 8vo.
2. Outlines of Agriculture. York. 1785. 8vo.
3. A new Method of raising Wheat for a Series of Years on the same Land. York. 1796. 4to.

1772. *Varlo, C. Esq.*
A New System of Husbandry. Lond. 3 vols. 8vo.

1774. *Barron, William, F.R.S.E.,* Professor of Logic and Belles Lettres in the University of St. Andrew's.
Essays on the Mechanical Principles of the Plough. Edin. 8vo.

1775. *Kent, Nathaniel,* of Fulham, Middlesex. He studied agriculture in Flanders, and became an eminent land valuer and agent. He was also for some time farm bailiff to George III. He died in 1818.
1. Hints to Gentlemen of Landed Property. Lond. 8vo.
2. General View of the Agriculture of the County of Norfolk; drawn up for the Board of Agriculture and Internal Improvement. Norwich, 1796. 8vo.
3. Account of the Improvements made on the Farm in the Great Park of His Majesty the King, at Windsor. (*Nicholson's Journal*, iii. 428.) 1799.

1775. *Harrison, Gustavus, Esq.*
Agriculture Delineated; or, the Farmer's Complete Guide, being a Treatise on Lands in general. 8vo.

1775. *Anderson, James, LL.D.,* an eminent agricultural writer, was born at Hermiston, a village near Edinburgh, in 1730, on a farm which his parents had possessed for some generations, and which he was intended to inherit and to cultivate. He lost his parents at an early age, but his education was not neglected; he studied chemistry under Dr. Cullen, and soon leaving his farm near Edinburgh, took one in Aberdeenshire of 1300 acres, which, after improving and cultivating for twenty years, he let, and enjoyed an annuity from it during his life. He settled, after leaving Aberdeenshire, in the neighbourhood of Edinburgh, where he published the *Bee*, in weekly sixpenny numbers, till it extended to 18 volumes. In 1797 he removed to Isleworth, near London, where he published *Recreations in Agriculture*, in six volumes, and his *Description of a Patent Hothouse*. Here he enjoyed his garden, and died of a decline in 1808, aged 69. Besides the works which bear his name, he wrote the reviews of books on rural matters for the *Monthly Review* for many years.
1. Essays relating to Agriculture and Rural Affairs. Edin. 8vo. Lond. 5 vols. 8vo.
2. Miscellaneous Thoughts on Planting and Training Timber Trees, by Agricola. Edin. 1777. 8vo.
3. An Account of the Present State of the Hebrides and Western Coasts of Scotland, with Hints for encouraging the Fisheries, and promoting other Improvements in these countries; being the Substance of a Report to the Lords of the Treasury. Edin. 1785. 8vo.
4. A Practical Treatise on Peat Moss, considered as in its Natural State fitted for affording Fuel, or as susceptible of being converted into Mould, capable of yielding abundant Crops of useful Produce, with full Directions for converting and cultivating it as a Soil. Edin. 1794. 8vo.
5. A General View of the Agriculture and Rural Economy of the County of Aberdeen, with Observations on the Means of its Improvement. Chiefly drawn up for the Board of Agriculture, in two parts. Edin. 1794. 8vo.
6. A Practical Treatise on Draining Bogs and Swampy

Grounds; with cursory Remarks on the Originality of Elkington's Mode of Draining. Lond. 1794. 8vo.

7. Recreations in Agriculture, Natural History, &c. Lond. 1799. 6 vols. 8vo.

1776. *Home, Henry,* usually called Lord Kames, an eminent Scotch lawyer, philosopher, and critic, was born at Kames, in Berwickshire, 1796; died 1782. He farmed his own estate in Berwickshire many years; he afterwards removed to Blair Drummond, near Stirling, where he made various and extensive improvements, the most important of which was the clearing, cultivating, and peopling great part of Flanders Moss.
The Gentleman Farmer; being an attempt to improve Agriculture, by subjecting it to the test of Rational Principles. Edin. 8vo.

1777—1816. *Anon.*
Letters and Papers on Agriculture, Planting, &c., selected from the Correspondence of the Bath and West of England Society. Bath. 14 vols. 8vo.

1777. *Clarke, Cuthbert.*
The true Theory and Practice of Husbandry, deduced from Philosophical Researches and Experience, &c. Lond. 4to.

1778. *Forbes, Francis,* gentleman.
1. The extensive Practice of the New Husbandry. Lond. 8vo.
2. The Improvement of Waste Lands. Lond. 1778. 8vo.

1778. *Wight, Andrew,* a farmer in East Lothian, and one of the earliest writers among that class in Scotland.
The Present State of the Husbandry in Scotland. Edin. 6 vols. 8vo.

1777. *Black, James,* of Morden, Surrey, a surveyor, in his day in great practice.
Observations on the Tillage of the Earth, and on the Theory of Instruments adapted to this end. Lond. 4to.

1778. *Marshall, William, Esq.,* a native of Yorkshire, brought up to trade; he was some years in the West Indies, as a planter; returned about 1775, and took a farm in Surrey; went down into Norfolk as agent to Sir Harbord Harbord's estate in 1780; he left this situation in 1784, and went and resided at Stafford, near the junction of the four counties of Leicester, Warwick, Stafford, and Derby, where he remained till 1786, occupied in collecting materials for his *Economical Survveys*, and in printing some of his works. From this time till about 1808, he resided chiefly in Clement's Inn, London, in winter, and visited different parts of the country during summer. He spent one summer in Perthshire, chiefly on the Earl of Breadalbane's estates at Taymouth; and partly also on the Earl of Mansfield's at Scone. He proposed arrangements for the tenantable land, and also the park and woody scenery on various estates; and finally retired to a considerable property he purchased in his native country, in the vale of Cleveland, in 1808, where he died at an advanced age in 1819. He was a man of little education, but of a strong and steady mind; and pursued in the most consistent manner, from the year 1780 to his death, the plan he originally laid down; that of collecting and condensing the agricultural practices of the different counties in England, with a view to a general work on *Landed Property*, which he published; another on *Agriculture*, which he did not live to complete; and a *Rural Institute*, in which he was supplanted by the Board of Agriculture.
1. Minutes of Agriculture, made on a Farm of 500 acres, of various Soils, near Croydon, Surrey. Lond. 4to.
2. Experiments and Observations concerning Agriculture and the Weather. Lond. 1779. 4to.
3. The Rural Economy of Norfolk. Lond. 1788. 2 vols. 8vo.
4. The Rural Economy of Yorkshire. Lond. 1788. 2 vols. 8vo.
5. The Rural Economy of Gloucestershire. Glouc. 1789. 2 vols. 8vo.
6. Rural Economy of the Midland Counties. Lond. 1790. 2 vols. 8vo.
7. Rural Economy of the West of England. Lond. 1796. 2 vols. 8vo.
8. The Rural Economy of the Southern Counties of England. Lond. 1798. 2 vols. 8vo.
9. Proposals for a Rural Institute, or College of Agriculture, and other Branches of Rural Economy. Lond. 1799. 8vo.
10. On the Appropriation and Enclosure of Commonable and Intermixed Lands. Lond. 1801. 8vo.
11. An Elementary and Practical Treatise on the Landed Property of England, containing the Purchase and Improvement of Landed Estates. Lond. 1804. 4to.
12. Treatise on the Management of Landed Estates. A General Work for the Use of Professional Men, being an Abridgment of the former. Lond. 1808. 8vo.
13. A Review and Complete Abstract of the Reports of the Board of Agriculture from theseveral Departments of England, Lond. 1817. 5 vols. 8vo.
14. Of the Black Canker Caterpillar which destroys the Turnips in Norfolk. (*Phil. Trans. Abr.* xv. 586.) 1785.

1780. *Boswell, George,* a cultivator of his own estate in Gloucestershire.
Treatise on Watering Meadows; wherein are shown the many Advantages arising from that Mode of Practice, particularly on coarse, boggy, or barren Lands. Lond. 8vo.

1784. *Twamley, J.*
Dairying exemplified; or the Business of Cheesemaking laid down from approved Rules, &c. Warwick, 8vo.
1784. *Small, James*, a plough-wright, and small farmer in Roxburghshire; but afterwards settled at Edinburgh as an agricultural machinist.
Treatise on Ploughs and Wheel Carriages. Edin. 8vo.
1784. *Turner, Nicholas.*
An Essay on Draining and Improving Peat Bogs. Lond. 8vo.
1785. *Stone, Thomas*, lately a surveyor and land-agent to the Duke of Bedford; died at Paris, 1815.
1. An Essay on Agriculture, with a View to inform Gentlemen of Landed Property whether their Estates are managed to the greatest Advantage. Lond. 8vo.
2. General View of the Agriculture of the County of Huntingdon. Lond. 1793. 4to.
3. General View of the Agriculture of the County of Bedford. Lond. 1794. 4to.
4. General View of the Agriculture of the County of Lincoln. Lond. 1794. 4to.
5. A Review of the corrected Agricultural Survey of Lincolnshire, by Arthur Young, Esq. Lond. 1800. 8vo.
6. A Letter on the Drainage of the East, West, and Wild Moor Fens. Lond. 1800. 8vo.
7. Letter on the intended Drainings and Inclosures of the Moor Fens in the County of Lincoln. 1801.
1786. *Young, David*, of Perth.
Natural Improvements in Agriculture, in Twenty-seven Essays. Edin. 8vo.
1786. *Culley, George*, born at Denton, in the county of Durham. In 1762 he went to Dishley, and remained some time a pupil with Bakewell: he then returned, and took the farm of Fenton, in Northumberland, in 1767, and died in that county, at Fowberry tower, in 1813, aged 79.
1. Observations on Live Stock; containing Hints for choosing, and improving the best Breeds of the most useful Kinds of Domestic Animals. Lond. 8vo.
2. General View of the Agriculture of Northumberland. (See Bailey, J., A.D. 1797.)
1787. *Ley, Charles*, land surveyor.
The Nobleman, Gentleman, Land Steward, and Surveyor's Complete Guide; in which is described every Circumstance relative to the proper Management of Estates; comprehending the Duty and Office of a Land Steward in all its Parts; with some useful Hints to Surveyors: also the Current Prices of Estates throughout the Kingdom, by which any Gentleman or Steward may ascertain the exact Value of any Estate, whether in Fee, Copy, or Leasehold. Lond. 8vo.
1787. *Winter, George*, a practical agriculturist.
A new and compendious System of Husbandry: containing the mechanical, chemical, and philosophical Elements of Agriculture. Brist. 8vo.
1789. *Adam, James*, Esq.
Practical Essays on Agriculture. Lond. 2 vols. 8vo.
1789. *Wright, Rev. Thomas*, Rector of Auld, in Northamptonshire,
1. Account of the Advantages and Method of Watering Meadows by Art, as practised in the County of Gloucester. Lond. 8vo.
2. The Art of Floating Land, as it is practised in the County of Gloucester, shown to be preferable to any other Method in use in this Country: with Minute and Plain Directions, and Three descriptive Plates. Lond. 1799. 8vo.
3. On the Formation and Management of Floated Meadows; with Corrections of Errors found in the Treatises of Messrs. Davis, Marshall, Boswell, Young, and Smith, on the Subject of Floating. 1810. 8vo.
1790. *Naismith, John*, an ingenious cultivator in Clydesdale.
1. Thoughts on various Objects of Industry pursued in Scotland. Edin. 8vo.
2. General View of the Agriculture of the County of Clydesdale. 1794. 4to.
3. Observations on the different Breeds of Sheep, and the State of Sheep Farming in the Southern Districts of Scotland. Edin. 1795. 4to.
4. Elements of Agriculture; being an Essay towards establishing the Cultivation of the Soil, and promoting Vegetation on steady Principles. Lond. 1807. 8vo.
1789. *Curtis, William*, an eminent botanist, born in Hampshire, 1746, died 1799; author of various works on practical botany and the culture of plants.
Practical Observations on the British Grasses best adapted to the laying down or improving of Meadows and Pastures. Lond. 8vo.
1790. *Swayne, G., A.M.*, vicar of Pucklechurch, Gloucestershire.
Gramina Pascua: or, a Collection of the Specimens of the Common Pasture Grasses. Lond. fol. 8 pages, and 6 plates.
1790. *Sinclair*, Right Hon. Sir *John*, Bart., LL.D., M.P., Founder of the Board of Agriculture, author of *The Code of Health and Longevity*, and various other compilations.
1. Report on the Subject of Shetland Wool. Lond. 8vo.
2. Address to the Society for the Improvement of British Wool, constituted at Edinburgh, 1791. Lond. 8vo.
3. Account of the Origin of the Board of Agriculture, and its Progress for Three Years after its Establishment. Lond. 1796. 4to.
4. Enquiry into the Nature and Causes of the Blight, the Rust, and the Mildew. 1809. 8vo.
5. An Account of the Systems of Husbandry adopted in the more improved Districts of Scotland; with some Observations on the Improvements of which they are susceptible. Edin. 1812. 8vo., with numerous plates.
6. The Agriculture of the Netherlands. 1816. 8vo.
7. The Code of Agriculture. 1820. 8vo.
1793. *Elstobb, W.*
Historical Account of the great Level of the Fens, called Bedford Level, and other Fens, Marshes, and Low Lands, in this Kingdom, and other Places. Lynn, 8vo.
1793. *Lebrocq, Philip*, M. A. and curate of Ealing.
The Outlines of a Plan for improving the Tract of Land called the New Forest. Lond. 8vo.
1793. *Fraser, Robert*, Esq.
1. General View of the Agriculture of the County of Devon. Lond. 4to.
2. General View of the Agriculture and Mineralogy, present State and Circumstances, of the County of Wicklow. Dub. 1801. 8vo.
3. Gleanings in Ireland; particularly respecting its Agriculture, Mines, and Fisheries. Lond. 1802. 8vo.
4. A Letter on the most effectual Means for the Improvement of the Coasts and Western Islands of Scotland, and the Extension of the Fisheries. Lond. 1803. 8vo.
5. Statistical Survey of the County of Wexford. Dub. 1807. 8vo.
1794. *Rennie, George*, Esq., an eminent East Lothian farmer, and also a proprietor.
General View of the Agriculture of the West Riding of Yorkshire, by Messrs. Rennie, Brown, and Shirreff. Lond. 4to.
1794. *Pringle, A.*
General View of the Agriculture of the County of Westmorland. Edin. 4to.
1794. *Malcolm, William, James, and Jacob*, of Stockwell, near Clapham, nurserymen.
1. General View of the Agriculture of Buckinghamshire. Lond. 4to.
2. General View of the Agriculture of the County of Surrey. Lond. 1794. 4to.
1794. *Maunsell, William*, LL.D.
Letter on the Culture of Potatoes from the Shoots. Lond. 8vo.
1794. *Leatham, Isaac.*
General View of the Agriculture of the East Riding of Yorkshire. Lond. 4to.
1794. *Monk, John*, of Bear's Combe, near King's-bridge, Devon.
1. An Agricultural Dictionary; consisting of Extracts from the most celebrated Authors and Papers. Lond. 3 vols. 8vo.
2. General View of the Agriculture of the County of Leicestershire. Lond. 1794. 4to.
1794. *Driver, Abraham and William*, land surveyors and agents, London.
General View of the Agriculture of the County of Hants. Lond. 4to.
1794. *Donaldson, James*, land surveyor, and land steward for some extensive estates, and author of some of the County Surveys.
Modern Agriculture; or the present State of Husbandry in Great Britain. Edin. 1795-6. 4 vols. 8vo.
1794. *Amos, William*, of Brothertoft, Lincolnshire, farmer.
1. The Theory and Practice of Drill Husbandry, &c. Lond. 4to.
2. Minutes of Agriculture and Planting, &c. Lond. 1804. 4to.
1794. *Davis, Thomas*, Esq., steward to the Marquis of Bath at Longleat; a man of strong mind and great integrity, universally respected; he died about 1818.
General View of the Agriculture of Wiltshire. Lond. 8vo.
1794. *Clark, John*, F.S.A., land surveyor, Builth, and at Pembroke.
1. General View of the Agriculture of Brecknock. Lond. 4to.
2. General View of the Agriculture of the County of Radnor. Lond. 1794. 4to.
3. General View of the Agriculture of the County of Hereford. Lond. 1794. 4to.
4. An Inquiry into the Nature and Value of Leasehold Property. Glouc. 8vo.
1794. *Pitt, William*, of Pendeford, near Wolverhampton.
1. General View of the Agriculture of the County of Stafford. Lond. 8vo.
2. A General View of the Agriculture of Northamptonshire. 8vo.
3. A General View of the Agriculture of Worcestershire. 1811.
1795. *Cochrane, Archibald*, Earl of Dundonald, an amateur chemist and agriculturist.
1. A Treatise showing the intimate Connection that subsists between Agriculture and Chemistry. Lond. 4to.
2. The Principles of Chemistry applied to the Improvement of the Practice of Agriculture. 1799. 4to.
1795. *Holt, John*, of Walton, near Liverpool, was born in Cheshire, 1742; died 1801.
1. General View of the Agriculture of the County of Lancaster; with the Observations on the Means of its Improvement; drawn up for the Board of Agriculture. Lond. 8vo.
2. An Essay on the Curl of Potatoes.
1795. *Robertson, George*, formerly farmer at Granton, near Edinburgh, now living in Ayrshire.
1. General View of the Agriculture of the County of Mid-Lothian. Edin. 8vo.
2. Rural Recollections; or the Progress of Improvement in Agriculture and Rural Affairs. Irvine. 8vo. 1829.
1795. *Macphail, James*, twenty years gardener to the Earl of Liverpool in Surrey, and author of *The Gardener's Remembrancer*, an esteemed work.
Hints and Observations on the Improvement of Agriculture. Lond. 8vo.

1796. *Kirkpatrick, H.*
An Account of the Manner in which Potatoes are cultivated and preserved, and the Uses to which they are applied in the Counties of Lancaster and Chester; together with a Description of a new Variety of Potatoes, peculiarly convenient for forcing in Hot-houses and Frames. Lond. 8vo.
1796. *Boys, John*, farmer at Betsanger in Kent.
A General View of the Agriculture of the County of Kent. Lond. 8vo.
1796. *Anstruther, Sir John*, Bart.
Remarks on the Drill Husbandry. Lond. 8vo.
1796. *Wright, Sir James*, Bart.
Observations upon the important Object of preserving Wheat and other Grain from Vermin. Lond. 4to.
1796. *Kirwan, Richard*, LL.D., F.R.S.L. and E., P.R.I.A., an eminent philosopher and various author; died 1812.
On the Manures most advantageously applicable to various Sorts of Soil, and the Causes of their Beneficial Influence in each particular Instance. Lond. 8vo.
1796. *Lawrence, John*, a veterinary surgeon.
1. Philosophical and Practical Treatise on Horses. Lond. 8vo.
2. The Sportsman, Farrier, and Shoeing Smith's new Guide; being the Substance of the Works of the late C. de St. Bel. 1796. 8vo.
3. The Modern Land Steward. Lond. 1802. 8vo.
4. A General Treatise on Cattle. Lond. 1805. 8vo.
5. The Farmer's Pocket Calendar. 1808.
6. The New Farmer's Calendar. 1809.
7. History and Delineation of the Horse in all its varieties, with 15 engravings by Scott. Lond. 1810.
8. The Horse in all his Varieties and Uses, &c. Lond. small 8vo. 1829.
- 1797—1819. *Anon.*
Communications to the Board of Agriculture. Lond. 7 vols. 4to. New Series, 1 vol. 8vo.
1797. *Morley, Christopher.*
Practical Observations on Agriculture, Draining, &c., in two Letters addressed to Sir John Sinclair. Lond. 4to.
1797. *Johnstone, John*, land surveyor and drainer at Edinburgh.
An Account of the most approved Mode of Draining Land, according to the System practised by the late Mr. Joseph Elkington. Edin. 4to. Subsequent editions in 8vo.
1797. *Lawson, John.*
Essay on the Use of mixed and compressed Cattle Fodder, particularly adapted for Horses and Cattle on Shipboard, in Camps, or in Garrisons, with useful Tables, &c. Lond. 8vo.
1797. *Dix, William Spier.*
Remarks on a newly invented Patent Machine, for clearing Grain from the Straw, instead of threshing it with the Flail. Lond. 4to.
1797. *Bailey, John*, Esq., originally a schoolmaster, afterwards steward to Lord Tankerville; a man of enlightened mind, various useful and elegant acquirements, and sound practical agricultural knowledge. He was much respected by all who knew him.
1. A General View of the Agriculture of the County of Northumberland, by J. Bailey and J. Culley. Newcastle. 8vo.
2. A General View of the Agriculture of Durham, &c. Lond. 1811. 8vo.
3. General View of the Agriculture of the County of Cumberland. 8vo.
1798. *Smith, Rev. John*, D.D., minister of Kilbrandon, in Argyleshire, afterwards one of the ministers of Campbelton.
A General View of the Agriculture of the County of Argyle. Edin. 8vo.
1798. *Douglas, Robert*, D.D., minister of Galashiels.
A General View of the Agriculture of the Counties of Roxburgh and Selkirk. Edin. 8vo.
1798. *Tatham, William.*
1. Remarks on Inland Canals, the System of Interior Navigation, and various Uses of the Inclined Plane. Lond. 4to.
2. The Political Economy of Inland Navigation, Irrigation, and Drainage; with Thoughts on the Multiplication of Commercial Resources, and on the Means of bettering the Condition of Mankind by Construction of Canals. 11 Plates. Lond. 1799. 4to.
3. Communication concerning the Agriculture and Commerce of America; containing observations on the Commerce of Spain with her American Colonies in the Time of War. Written by a Spanish Gentleman, and now edited with sundry other Papers relating to the Spanish Interest. Lond. 1800. 8vo.
4. An Historical and Practical Essay on the Culture and Commerce of Tobacco. Lond. 1800. 8vo.
5. National Irrigation; or the various Methods of Watering Meadows; affording Means to increase the Population, Wealth, and Revenue of the Kingdom, by an Agricultural, Commercial, and general Economy in the Use of Water. Lond. 1801. 8vo.
6. Auxiliary Remarks on an Essay on the comparative Advantages of Oxen for Tillage in competition with Horses. Lond. 1801. 8vo.
7. Two Reports on the Navigation of the River Thames. Lond. 1803. 8vo.
1798. *Middleton, John*, Esq., land surveyor, London.
1. A View of the Agriculture of Middlesex. Lond. 8vo.
2. Observations on the various Kinds of Manure. (*Nicholson's Journal*, iii. 340.) 1799.
- 1799—1815. *Anon.* and *W. Dickson*, the author of *Practical Agriculture*.
The Commercial and Agricultural Magazine. 13 vols. 8vo. to 1808. Continued by Dr. W. Dickson, London, from 1808 to 1812. 11 vols. 8vo. New Series, from 1813 to 1815. 6 vols. 8vo.
- 1799—1830. *Anon.*
Prize Essays, and Transactions of the Highland Society of Scotland. Edin. to 1820. 6 vols. 8vo. New Series, published in *The Quarterly Journal of Agriculture*, commencing 1823, to 1831. 2 vols. forming the 7th and 8th.
1799. *Wright, Thomas.*
The Art of Floating Land, as it is practised in the County of Gloucester. Lond. 8vo. 3 Plates.
1799. *Parkinson, Richard*, of Doncaster, a farmer, traveller in America, and afterwards steward to Sir Joseph Banks, in Lincolnshire.
1. The Experienced Farmer. Lond. 2 vols. 8vo.
2. A Tour in America, in 1798, 1799, and 1800; exhibiting a particular Account of the American System of Agriculture, with its recent Improvements. Lond. 1805. 2 vols. 8vo.
3. The English Practice of Farming, exemplified in the Management of a Farm in Ireland. Lond. 1806. 8vo.
4. Treatise on the Breeding and Management of Live Stock. Lond. 1809. 2 vols. 8vo.
5. General View of the Agriculture of Huntingdonshire. Lond. 1811. 8vo.
1799. *Brown, Robert*, Esq., formerly farmer at Markle, near Haddington, one of the projectors, and for many years editor, of the *Farmer's Magazine* (see 1800.); a man of vigorous intellect, sound knowledge in political economy, energetic language, and an excellent bean and wheat farmer.
1. General View of the Agriculture of the West Riding of Yorkshire, surveyed by Messrs. Rennie, Brown, and Shirreff, in 1793. Lond. 8vo.
2. Treatise on Rural Affairs; originally published in the Edinburgh Encyclopædia. Lond. 1811. 2 vols. 8vo.
3. Letters on the Distressed State of Agriculturists. 1816.
1799. *Banister, John*, Gent., of Horton Kirby, in Kent.
A Synopsis of Husbandry. Lond. 8vo.
1799. *Somerville, Right Hon. John*, Lord. He died at Vevay in Switzerland, on his way to Italy, about 1815, was buried in the churchyard there, and afterwards disinterred and brought to England.
1. Address to the Board of Agriculture on the Subject of Sheep and Wool. Lond. 8vo.
2. The System followed during the Two last Years by the Board of Agriculture, &c. 1800. 4to.
3. Facts and Observations relative to Sheep, Wool, Ploughs, and Oxen, &c. Lond. 1803. 8vo.
1799. *Robertson, James*, D.D., minister at Callander, Perthshire.
1. General View of the Agriculture of the County of Perth. Perth. 8vo.
2. General View of the Agriculture of Inverness-shire. 8vo.
3. General View of the Agriculture of Kincardineshire. 1811. 8vo.
- 1800—1825. *Anon.* (R. Brown of Markle, near Haddington, farmer, and afterwards J. Cleghorn of Edinburgh, accountant.)
Farmer's Magazine. Edin. 26 vols. 8vo. Plates.
1800. *Washington, Gen. George*, first president of the United States of America, and commander in chief of the armies, was born in the county of Virginia, 1732; died 1799. The most illustrious character of the age in which he lived; his mantle seems to have fallen on General Lafayette.
1. Letters from him to Sir John Sinclair, on Agricultural and other interesting Topics; engraved from the original Letters, so as to be an exact Fac-simile of the Handwriting of that celebrated Character. Lond. 4to.
2. Letters to Arthur Young, Esq., containing an Account of his Husbandry, with a Map of his Farm; his Opinions on various Questions in Agriculture, and many Particulars of the Rural Economy of the United States. Lond. 1801.
1800. *Thomson, Rev. John*, D.D.
General View of the Agriculture of the County of Fife. Edin. 8vo.
1800. *Stacey, Rev. Henry Peter*, LL.B., F.L.S.
Observations on the Failure of Turnip Crops. Lond. 8vo.
1800. *Parry, Caleb Hillier*, M.D., F.R.S., physician, Bath. He cultivated his own estate, and greatly improved the Merino-ryland breed of sheep. Facts and Observations, tending to show the Practicability, and Advantage to the Individual and the Nation, of producing in the British Isles Clothing-wool equal to that of Spain; together with some Hints towards the Management of fine-woolled Sheep. Lond. 8vo.
1800. *Dalrymple, William*, Esq.
Treatise on the Culture of Wheat. Lond. 8vo.
1800. *Darwin, Erasmus*, M.D., F.R.S., an eminent physician, philosopher, and poet, was born near Newark, in Nottinghamshire, 1731; died 1802. *Phytologia*; or the Philosophy of Agriculture and Gardening. Lond. 4to.
1802. *Alderson, John*, M.D., physician at Hull.
On the Improvement of Poor Soils, in Answer to the following Question:—"What is the best Method of cultivating and improving Poor Soils, where Lime and Manure cannot be had?" Lond. 8vo.
1802. *Bartley, Nehemiah*, Esq., secretary to the Bath Agricultural Society.
Some cursory Observations on the Conversion of Pasture Lands into Tillage, and, after a certain Course of Crops, relaying the same into Pasture, &c. Lond. 8vo.
1802. *Tighe, William*, Esq.
Statistical Observations relative to the County of Kilkenny. Dub. 8vo.

1802. *Bell, Benjamin*, F.R.S.E., surgeon, Edinburgh.

Essays on Agriculture. Edin. 8vo.

1802. *Findlater, Rev. Charles*, minister of the parish of Newlands, in the county of Peebles; a man of sound views of political economy, whose work, and whose communications to the *Farmer's Magazine*, have greatly enlightened the farmers in Scotland, on the subjects of rent, demand and supply, market prices, value, &c.

General Survey of the Agriculture of the County of Peebles. Edin. 8vo.

1804. *Knapp, J. L.*, Esq., F.L. and A.S.S., author of *The Journal of a Naturalist*.

Gramina Britannica, or Representations of the British Grasses; with Remarks and occasional Descriptions. Lond. 4to.

1804. *Dickson, R. W.*, M.D., of Hendon, Middlesex, author of various works. He died in London, in penurious circumstances, in 1824.

1. Practical Agriculture. Plates. Lond. 2 vols. 4to.

2. Agricultural Magazine; or Farmer's Monthly Journal of Husbandry and Rural Affairs, &c. From July 1807, to December 1808. 8 vols. 8vo. (See 1799.)

3. The Farmer's Companion; being a complete System of Modern Husbandry. (Being Practical Agriculture, with a new title-page!) Lond. 1811. 4to.

4. An improved System of Cattle Management. Lond. 1822. 2 vols. 4to.

1804. *Forsyth, Robert*, Esq. advocate, Edinburgh, author of *Elements of Moral Science*, and other esteemed philosophical works.

Principles and Practice of Agriculture systematically explained; being a Treatise compiled for the Fourth Edition of the Encyclopædia Britannica, revised and enlarged. 2 vols. 8vo.

1805. *Luccock, John*, woolstapler at Leeds.

1. The Nature and Properties of Wool illustrated; with a Description of the English Fleece. Leeds. 12mo.

2. An Essay on Wool; containing an Examination of the present Growth of Wool in every District throughout the Kingdom, and the Means pointed out for its Improvement. 1807.

1805. *Pearson, George*, M.D., F.R.S., senior physician to St. George's Hospital, lecturer in chemistry, and on the theory and practice of medicine in London.

A Communication to the Board of Agriculture, on the Use of Green Vitriol, or Sulphate of Iron, as a Manure; and on the Efficacy of Paring and Burning depending partly on Oxide of Iron. Lond. 4to.

1805. *Somerville, Robert*, a surgeon in Haddington, and for some time joint editor with Brown of Markle of *The Farmer's Magazine*. (See 1799.) He died in 1803.

General View of the Agriculture of East Lothian, from the papers of the late Robert Somerville. Lond. 8vo.

1805. *Aiton, William*, sheriff-substitute for the middle ward of Lanarkshire, author of various papers in *The Farmer's Magazine*.

1. Essay on the Origin, Qualities, and Cultivation of Moss Earth. Glasg. 8vo.

2. General View of the Agriculture of the County of Ayr, with Observations on the Means of its Improvement. Glasg. 1811. 8vo.

3. General View of the County of Bute, &c. Glasg. 1816. 8vo.

4. A Treatise on Dairy Husbandry. Edin. 8vo. 1825.

1805. *Barber, William*, a London architect.

1. Farm Buildings; containing Designs for Cottages, Farmhouses, Lodges, Farm-yards, &c. Six Plates. Lond. 4to.

2. A Description of the Mode of Building in Pisé. 1806. 4to.

1805. *Hood, Thomas Sutton*, Esq.; sometimes called *Sutton Thomas Wood*.

A Treatise on Gypsum; on its various Uses, and on its Application as a Manure. 8vo.

1805. *Malcolm, James*, land surveyor to the Prince of Wales, &c.

A Compendium of Modern Husbandry, &c. Lond. 3 vols. 8vo.

1806. *Smith, William*, engineer and mineralogist; a man of extraordinary exertion and merit, more especially as having been the first to compose a geological map of England, and also most valuable county geological maps.

1. The Improvement of Bogy Land by Irrigation, as carried into effect by him. Lond. 8vo.

2. Observations on the Utility, Form, and Management of Water Meadows, and the Draining and Irrigating Peat-bogs; with an Account of Prisle Bog, and other extraordinary Improvements conducted for the Duke of Bedford. Lond. 1809. 8vo.

3. Geological Map of England and Wales and part of Scotland. 1815.

4. Geological Table of British organised Fossils. 1819.

5. County Geological Maps. 1819.

1806. *Ainslie, John*, a land surveyor at Edinburgh.

1. Tables for computing the Weight of Hay, Cattle, &c. by Measurement. Lond. 12mo.

2. Farmer's Pocket Companion. Edin. 1812. 8vo.

1807. *Vancouver, Charles*, land valuer.

1. A General View of the Agriculture of the County of Devon. Lond. 8vo.

2. General View of the Agriculture of Hampshire, including the Isle of Wight. 1811. 8vo.

1807. *Holland, Henry*, Esq., M.D., honorary member of the Geological Society, author of *Travels in Greece*, and other works; an eminent London physician.

General View of the Agriculture of Cheshire. Lond. 8vo.

1807. *Headrick, James*, a clergyman in Angleshire, an excellent chemist, a good naturalist, and an agricultural philosopher.

1. View of the Mineralogy, Agriculture, Manufactures, and Fisheries of the Island of Arran, &c. Edin. 8vo.

2. General View of the Agriculture of the County of Angus. 1813. 8vo.

1808. *Tibbs, Thomas*, farmer.

The Experimental Farmer. 8vo.

1808. *Coventry, Andrew*, M.D., professor of agriculture in the university of Edinburgh; a learned, ingenious, and most benevolent man. He cultivated his own estate in Kinross-shire, and was extensively employed as a land valuer and rural counsellor. He died in December 1830.

1. Discourse explanatory of the Nature and Plan of a Course of Lectures on Agriculture and Rural Economy. Edin. 8vo.

2. Observations on Live Stock, in a Letter to Henry Cline, Esq. Edin. 8vo.

3. Notes on the Culture and Cropping of Arable Land. Edin. 1812. 8vo.

1808. *Gray, Andrew*, a retired machinist at Edinburgh.

Plough-wright's Assistant; or, a Practical Treatise on various Implements employed in Agriculture; illustrated with 16 Engravings. Edin. 8vo.

1808. *Beddoes, Thomas*, M.D., born in Shropshire, 1760, was lecturer in Botany, at Oxford, and afterwards physician at Bristol, where he died, 1808.

1. Good Advice for the Husbandman in Harvest, and for all those in Labour in Hot Births; as also for others who will take it in Warm Weather. 8vo.

2. On the Means of foretelling the Character of the Summer Season, and the Benefits to be expected from the Cultivation of Grasses which vegetate at low Temperatures. (*Nic. Jour. v. 151.*) 1802.

1808. *Bakewell, Robert*, Esq., an eminent geologist and mineralogist, author of *Travels in the Tarentaise, &c.*; an instructive and entertaining work, published in 1823.

Observations on the Influence of Soil and Climate upon Wool, with an easy Method of improving the Quality of English Clothing Wool, and Hints for the Management of Sheep, &c.; with occasional Notes and Remarks by the Right Hon. Lord Somerville. Lond. 8vo.

1808. *Dutton, Hely*, Esq., landscape gardener.

1. Statistical Survey of the County of Clare. Dublin, 8vo.

2. Statistical Survey of the County of Galway. Dublin, 1824. 8vo.

1808. *Curwen, John Christian*, M.P., of Workington Hall, Cumberland.

1. Hints on the Economy of Feeding Stock, and bettering the Condition of the Poor. Lond. 8vo.

2. A Tour in Ireland. 2 vols. 8vo. 1819.

1809. *Stevenson, W.*, Esq., M.A., librarian to the Treasury, author of various works, and a writer in the principal encyclopædias. He died in 1829.

General View of the Agriculture of the County of Surrey. Lond. 8vo.

1809. *Kerr, Robert*, surgeon, F.R. and A.S.S. Edinburgh, an excellent naturalist and general scholar; died, 1814.

Statistical, Agricultural, and Political Survey of Berwickshire. 8vo.

1809. *Williamson, Capt. Thomas*, upwards of 20 years in Bengal.

Agricultural Mechanism; or, a Display of the several Properties and Powers of the Vehicles, Implements, and Machinery connected with Husbandry. Lond. 8vo.

1810. *Davies, Walter*, A.M.

A General View of the Agriculture and Domestic Economy of North Wales. Lond. 8vo.

1810. *Hunt, Charles Henry*, Esq.

Treatise on the Merino and Anglo-Merino Breeds of Sheep. Lond. 8vo.

1810. *Adams, George*.

A New System of Agriculture and Feeding Stock. Lond. 8vo.

1810. *Farish, John*, Dumfries.

A Treatise on Fiorin Grass. 8vo.

1810. *Edgeworth, Richard Lovell*, Esq., F.R.S. and M.R.I.A., civil engineer, resident at Edgeworth Town, Ireland, author of various works.

An Essay on the Construction of Roads and Carriages. Lond. 8vo.

1811. *Keith, George Skecne*, D.D.

A General View of the Agriculture of Aberdeenshire. 8vo.

1811. *Henderson, Robert*, farmer at Broomhill, near Annan, Dumfriesshire.

Treatise on the Breeding of Swine and Curing of Bacon; with Hints on Agricultural Subjects. Edin. 8vo.

1811. *Farcy, John*, sen., mineral surveyor. A man of sound views on all subjects; a philosopher and an agriculturist, and territorial improver of great experience.

General View of the Agriculture and Minerals of Derbyshire. Lond. 3 vols.

1811. *Loudon, John Claudius*, F.L.G. Z. and H.S., landscape gardener, author of the *Encyclopædia of Gardening*, and other works, and founder and con-

ductor of the *Gardener's Magazine*, and of the *Magazine of Natural History*; born in Lanarkshire in 1782, began to practise in 1803; to farm extensively in Oxfordshire in 1809, and in Middlesex in 1810; travelling on the Continent in 1813-14-15, in 1819, and again in 1828-29; now residing at Bayswater.

1. Designs for laying out Farms and Farm Buildings in the Scotch Style, adapted to England; comprising an Account of the Introduction of the Berwickshire Husbandry into Middlesex and Oxfordshire. Lond. 4to.

2. An Encyclopædia of Agriculture. Lond. 8vo. 1825.

1813. *Walker, W.*

An Essay on Draining Land by the Steam Engine. Lond. 8vo.

1813. *Davy, Sir Humphry*, president of the Royal Society, LL.D., V.P.R.I., F.R.S., Edin. M.R.I.A., &c.

Elements of Agricultural Chemistry; in a Course of Lectures for the Board of Agriculture. 4to and 8vo.

1814. *Shirreff, John*, farmer at Captain Head, near Haddington, Scotland, and one of the authors of the *Survey of the West Riding of Yorkshire*, along with Mr. Brown and Mr. Rennie (see 1799); afterwards a land agent, and finally steward to a nobleman near Stirling.

General View of the Agriculture of the Orkney Islands. Edin. 8vo.

1815. *Moubray, Bonnington, Esq.*

A practical Treatise on the Method of Breeding, Rearing, and Fattening Domestic Poultry, Pigeons, and Rabbits. 8vo.

1815. *Little, John.*

Practical Observations on the Improvement and Management of Mountain Sheep and Sheep Farms. 8vo.

1814—1815. *Simpson, Pinder.*

1. Treatise on the Cultivation of Mangold Wurzel, as Winter Food for Cattle. Lond. 8vo.

2. On the improved Beet-root as Winter Food for Cattle.

1815. *Birkbeck, Morris, Esq.*, formerly a farmer in Suffolk, afterwards an extensive proprietor and resident cultivator in the Illinois. Drowned there in 1825.

1. Notes in a Journey through France from Dieppe, through Paris and Lyons to the Pyrenees, and back through Toulouse in 1814; describing the Habits of the People, and the Agriculture of the Country. 8vo.

2. Notes in a Journey in America, from the Coast of Virginia to the Territory of Illinois. Lond. 1818. 8vo.

1815. *Hornby, Thomas, Esq.*, surgeon, York.

Dissertation on Lime, and its use and abuse in Agriculture, embracing a View of its Chemical Effects. 8vo.

1816. *Anderson, William*, farmer, Angusshire.

Observations on a new Mode of Stacking Corn, peculiarly adapted to Wet Seasons; recommending a Plan, successfully practised, by which corn may be stacked with advantage soon after being cut down. 8vo.

1818. *Macwilliam, Robert, Esq.* architect and surveyor, London.

An Essay on the Origin and Operation of the Dry Rot; to which are annexed, Suggestions for the Cultivation of Forest Trees, and an Abstract of the Forest Laws. 4to.

1819. *Radcliffe, Rev. T.*

A Survey of the Husbandry of Eastern and Western Flanders, made under the Authority of the Dublin Farming Society. 8vo.

1819. *Williams, T. W.*

The Farmer's Lawyer; containing the Whole of the Law and local Customs in regard to Agricultural Possessions, Properties, and Pursuits. 8vo.

1819. *Swinbourne, R.*

The Farmer's New and Complete Account Book.

1819. *Blaikie, Francis*, first gardener, and afterwards steward to T. W. Coke, Esq. M.P. of Holkham.

1. On the Conversion of arable Land into Pasture, and on other rural Subjects. Lond. 1819. 12mo.

2. On the Management of Farm-yard Manure, and on other rural Subjects. Lond. 1819. 12mo.

3. A Treatise on the Management of Hedge and Hedgerow Timber. 12mo.

4. On the Economy of Farm Yard Manure, &c. 12mo. 1820.

5. On Mildew, and the Culture of Wheat. 12mo. 1821.

6. On Smut in Wheat. 12mo. 1822.

1820. *Rigby, Edward, M.D.* F.L.S.

1. Framlingham, its Agriculture, &c., including the Economy of a small Farm. 8vo.

2. Holkham, its Agriculture, &c. 8vo. 1821.

1820. *Grisenthwaite, William*, apothecary, of Wells, in Norfolk.

A new Theory of Agriculture, in which the Nature of Soils, Crops, and Manures is explained, many prevailing Prejudices are exploded, and the Application of Bones, Gypsum, Lime, Chalk, &c. determined on scientific Principles. 12mo.

1820. *Monteath, Robert*, a forester in considerable practice as agent and valuator.

The Forester's Guide. Stirling. 12mo. 2d edition with Additions, &c. Edin. 8vo. 1824, plates.

1820. *Mather, John*, Castle Hill, Carse of Gowrie.

The Farmer and Land Steward's Assistant; or, a Specimen of Farm Book-keeping, exhibiting, in a concise and simple Form, the Transactions in the arable, grazing, and woodland Departments; a general Cash Account; and an Account of the Charge and Discharge upon each Department; the Whole selected from Books of real Business. 4to.

1820. *Johnson, Cuthbert William*, F.L. and H.S.

An Essay on the Uses of Salt for Agricultural Purposes, with Instructions for its Employment as a Manure, and in the Feeding of Cattle, &c. New Edition in 1827.

1820. *Burroughs, Edward, Esq.*

Essays on Practical Husbandry and Rural Economy, 8vo.

1820. *Beatson, Major General Alexander*, late Governor of St. Helena, &c.

A new System of Cultivation without Lime or Dung on Summer Fallows, as practised at Knowle Farm, in the County of Sussex. Lond. 1820, 8vo, Plates, and Supplement. 1821, 8vo, Plates.

1822. *Finlayson, John*, of Kaines, near Muirkirk, Inventor and Patentee of the self-cleaning Ploughs and Harrows, a practical farmer and an ingenious man.

A Treatise on Agricultural Subjects. 8vo, plates. Subsequently changed to The British Farmer, &c. London. 1830. 8vo.

1822. *Salisbury, W.*, formerly a botanical nurseryman, now a private teacher of botany, &c.

The Cottager's Agricultural Companion. 12mo.

1822. *Munro, Colonel Innes.*

A Guide to Farm Book-keeping, founded upon actual Practice, and upon new and concise Principles. Royal 8vo.

1822. *Napier, Hon. William John*, F.R.S. Edin. post captain in the Royal Navy; a vice-president of the Pastoral Society of Selkirkshire, &c.

A Treatise on Practical Store Farming, as applicable to the Mountainous Region of Ettrick Forest, and the Pastoral District of Scotland in general. With Engravings. 8vo.

1822. *Cleghorn, James, Esq.*, formerly a practical farmer, afterwards editor of *The Farmer's Magazine*, author of the article "Agriculture" in the Supplement to the *Encyc. Brit.*, and of various articles in that work. One of the best modern writers on agriculture. Mr. C. is now an accountant in Edinburgh.

On the depressed State of Agriculture. Edin. 8vo.

1823. *Fairbairn, John.*

A Treatise upon Breeding, Rearing, and Feeding Cheviot and Black-faced Sheep in high Districts; with Observations on laying out and conducting a Store Farm, &c. Berwick. 8vo.

1823. *Low, David, Esq.* said to be editor of the *Quarterly Journal of Agriculture.*

Observations on the present State of Landed Property, and on the Prospects of the Landholder, and the Farmer. Edin. 8vo.

1824. *Morice, Francis.*

An Essay on Agriculture, and the Management of Landed Estates. Aberdeen. 8vo.

1824. *Sinclair, George*, F.L.S. F.H.S., formerly gardener to the Duke of Bedford, at Woburn, now of the firm of Cormack, Son, and Sinclair, nurserymen, New Cross, Deptford.

Hortus Gramineus Woburnensis; or, an Account of the Results of various Experiments on the Produce and Fattening Properties of different Grasses, and other Plants used as the Food of the more valuable domestic Animals; instituted by John Duke of Bedford. To which is added, an Appendix, pointing out the different Grasses best adapted for the Manufacture of Leghorn Bonnets, &c. Lond. Royal 8vo.

1824. *Western, C. C., Esq.* M.P.

A few Practical Remarks on the Improvement of Grass Land, by means of Irrigation, Winter-flooding, and Drainage; in a Letter to the Owners and Occupiers of Land in the County of Essex. Lond. 8vo.

1824. *Slaney, Robert A., Esq.* barrister.

Essay on the beneficial Direction of Rural Expenditure. Lond. 12mo.

1825. *Holditch, Benjamin*, a farmer on the Duke of Bedford's estate, near Peterborough, and for some time editor of the *Farm. Journ.* newspaper.

Essay on the Weeds of Agriculture. Lond. 8vo. Edited by G. Sinclair, for the benefit of his widow.

1825. *Hayward, Joseph*, author of the Science of Horticulture.

The Science of Agriculture, comprising a Commentary on, and comparative Investigation of, the Agricultural Chemistry of Mr. Kirwan, and Sir Humphry Davy; and the Code of Agriculture of Sir John Sinclair, Sir Joseph Banks, and other Authors on the subject; with Remarks on the Rust, or black Blight in Wheat; of which the true Cause and its Prevention are explained. Lond. 8vo.

1825. *Anon.*

A Treatise on Milk. Lond. 8vo.

1825. *Bayldon, J. S.*, land-agent and appraiser.

The Art of valuing Rents and Tillages, and the Tenants Right on entering and quitting Farms. 2d edit. Lond. 8vo.

1825. *Buchanan, George*, civil engineer.

A Treatise on Road-making, Railways, Wheel Carriages, and the Strength of Animals.

1825. *Cleghorn, James*, accountant in Edinburgh, conductor of the *Farmer's Magazine.*

Thoughts on the Expediency of a General Provident Institution for the Benefit of the Working Classes, &c. &c. Edin. 8vo.

1826. *Steele, Andrew*, a proprietor in the neighbourhood of Edinburgh.

The National and Agricultural History of Peat Moss, &c. Edinburgh, 8vo.

1826. *Withers, William*, junior, Esq. of Holt, Norfolk.

A Memoir addressed to the Society for the Encouragement of Arts, Manufactures, and Commerce, on the Planting and Rearing of Forest Trees, &c. &c. Holt and London, 8vo. pamph.

1826. *Waistell, Charles, Esq.*, chairman of the

Committee of Agriculture, of the Society of Arts. Edited by Joseph Jopling, architect, member of the Institution of Civil Engineers, inventor of the Sep-tenary System of generating Lines by simple continuous Motion, Instruments for drawing Curves, &c. &c.

Designs or Agricultural Buildings, &c. &c.: to which are added, Plans and Remarks on Caterham Farm-yard, as it formerly was; and also as it has been improved. Lond. 8vo.

1826. *Collyns, W.*, Esq., surgeon, Kenton, near Exeter.

Ten Minutes' Advice to my Neighbours, on the Use and Abuse of Salt as a Manure, &c. Exeter, pamph. 8vo.

1826—1831. *Fleming*, —, and *J. Main*.

Fleming's British Farmer's Magazine. Lond. 2 vols. 8vo. Continued under the name of the *British Farmer's Magazine*, 2 vols. 8vo.

1827. *Anon.*

The Farmer's Register and Monthly Magazine of Foreign and Domestic Events. Glasgow. In 8vo numbers, monthly. Completed in one volume.

1828. *Meadows, Arthur*, Esq.

Hints to the Farmers of the Baronies of Forth and Bargo on the Cultivation of Mangold Wurzel, Beans, Carrots, and Parsneps. Wexford, 8vo.

1828—1831. *Anon.*, believed to be *David Low*, Esq.

The Quarterly Journal of Agriculture. Edinburgh, 2 vols. 8vo.

The Prize Essays and Transactions of the Highland Society of Scotland are publishing along with this work. See 1799.

1828. *Kennedy, Lewis*, Esq., son of Mr. Kennedy the late eminent nurseryman of Hammersmith, steward to Lord Willoughby De Eresby, author of the *Tenancy of Land in Great Britain*, &c.

1. On the Cultivation of the Waste Lands in the United Kingdom, for the purpose of finding Employment for the able Poor now receiving Parochial Aid, and thereby diminishing the heavy Burdens of the Poor Rates; and on the Expediency of making some Provision for the aged and disabled Paupers of Ireland. Lond. 8vo.

2. The present State of the Tenancy of Land in Great Britain; showing the principal Customs and Practices between incoming and outgoing Tenants, &c. Lond. 8vo.

1829. *Lambert, Joseph*, Esq.

Observations on the Rural Affairs of Ireland, or a Practical Treatise on Farming, Planting, and Gardening, adapted to the Circumstances, Resources, Soil, and Climate of the Country. Dublin, 8vo, pp. 527.

1829. *Stephens, George*, drainer, member of the Nerecian and Wermlandska Agricultural Societies in Sweden.

The Practical Irrigator; being an Account of the Utility, Formation, and Management of Irrigated Meadows, with a particular Account of the Success of irrigation in Scotland. To which is added, a Practical Treatise on straightening

Water-courses, protecting River Banks, and embanking Low Lands. Edin. 8vo.

1829. *Doyle, Martin*.

Hints originally intended for the small Farmers of the County of Wexford; but suited to the Circumstances of many Parts of Ireland. Dublin, 18mo.

1829. *Fall, Thomas*, Surveyor of Roads.

The Surveyor's Guide; or, every Man his own Road-maker: comprising the whole Art of making and repairing Roads, Prices for Work. East Retford. 12mo.

1829. *Harley, William*, originally a manufacturer in Glasgow; afterwards a great cow-keeper and builder there. He died in London in 1830.

The Harleian Dairy System, and an Account of the various Methods of Dairy Husbandry pursued by the Dutch. Also, a new and improved Mode of ventilating stables; with an Appendix, containing useful Hints (founded on the Author's experience) for the Management of Hedgerow Fences, Fruit Trees, &c., and the Means of rendering Barren Land fruitful. Lond. 8vo.

1829. *Strickland, G.*, Esq.

A Discourse on the Poor Laws of England and Scotland, on the Poor of Ireland, and on Emigration. Lond. 8vo.

1829. *Trimmer, Joshua Kirby*.

Practical Observations on the Improvement of British Fine Wool, and the National Advantages of the arable System of Sheep Husbandry; with Remarks on the Saxon and French Systems.

1830. *Anon.*

The Library of Useful Knowledge; Farmer's Series. 8vo, 15 numbers to January 1, 1831.

1830. *Jennings, James*, Esq., author of the *Family Cyclopædia*, &c.

A Practical Treatise on the History, Medical Properties, and Cultivation of Tobacco. London.

1830. *Berry*, the Rev. *Henry*, an extensive farmer in Worcestershire, and understood to be the principal proprietor of the *British Farmer's Magazine*.

Improved Short-horns, and their Pretensions stated; being an Account of this celebrated Breed of Cattle, derived from authentic Sources: to which is added, an Enquiry as to their Value for General Purposes, placed in Competition with the improved Herefords. Lond. pamph. 8vo. 2d edit.

1830. *Brodigan, Thomas*, Esq.

A Botanical, Historical, and Practical Treatise on the Tobacco Plant, in which the Art of growing and curing Tobacco in the British Isles is made familiar to every Capacity, as deduced from the Observations of the Author in the United States of America, and his Practice in Field Cultivation in Ireland. Lond. 8vo.

1830. *Davey, John*, Esq.

Observations on the Disease which has lately been so destructive to Sheep, called Bane or Coath; particularising the Causes, and minutely describing the Modes of effecting its Cure; and pointing out those Means which ought to be adopted to prevent its Recurrence. Bath, pamph. 8vo.

SECT. II. Bibliography of Agriculture in Foreign Countries.

7899. *Numerous works on agriculture* are published in the French and German languages, and a considerable number in the Italian; but a great proportion of these are translations from British authors. Very few agricultural books have been printed in the Dutch, Flemish, Danish, Swedish, Polish, Spanish, or Portuguese languages, and scarcely any in those of Russia or Hungary. We shall notice the principal French, German, and Italian works, exclusive of translations, and add a few American books.

SUBSECT. 1. Bibliography of French Agriculture.

7900. *Of French books on agriculture* we have given a selection only: those who wish to see a complete list are referred to the *Bibliographie Agronomique*, Paris, 8vo; in which are given the titles of upwards of 2000 works, including translations and books on gardening. A general idea of French culture in all its branches may be obtained from the *Nouveau Cours Complet d'Agriculture*, 16 vols. 8vo (edition of 1821.), compiled by the members of the Section of Agriculture of the French Institute, each of whose names are given to the articles he contributed.

1529. *Etienne, Charles*, et *J. Liébault*, physicians. *Etienne, i.e. Stephanus* or *Stephens*, in the beginning of the sixteenth century published various small tracts on Gardening and other rural topics; and in 1529 he collected them together and published them, under the title of *Prædium Rusticum*, treating of gardens, trees, vines, fields, meadows, lakes, forests, orchards, &c. Having married his daughter to Liébault, they afterwards studied agriculture conjointly, and published the *Maison Rustique*, the modern editions of which are still the most popular agricultural works in France.

1. *Prædium Rusticum*; in fol.

2. *L'Agriculture et Maison Rustique*. Paris, in 4to, 1570.

1569. *Hesson, Jacques*, of Dauphiny. *De l'Art et Science de trouver sùrement les Eaux, Sources, et Fontaines cachées sous Terre, autrement que par les Moyens Vulgaires des Agriculteurs et Architectes*, in 4to.

1583. *Hegemon, Philibert*, a lawyer born at Châlons-sur-soane. Died in 1595.

La Colombière et Maison Rustique, contenant une Description des Douze Mois et des Quatre Saisons de l'Année, avec Enseignement de ce que le Labourcur doit faire par chaque Mois. Paris, in 8vo.

1600. *Serres, Olivier de*, the Lord of Predel in Languedoc. He was born in 1539, and died in 1619, at the age of 80 years. He was employed by Henry IV. to form a plantation of the white mulberry in the garden of the Tuilleries; and he is generally considered as the father of the culture of that tree in France. He published a great many useful works, the principal of which is his *Théâtre d'Agriculture*, the first edition of which was published in 1600, and the 20th in 1675.

Le Théâtre d'Agriculture et Mesnage des Champs. Paris, small 8vo. An enlarged edition in 2 vols. 4to, with voluminous Notes, and a Historical Introduction, in 1804.

1602. *Letellier*.

Brief Discours contenant la Manière de nourrir les Vers à Soie, &c. Avec de belles Figures. Paris, in 4to.

1604. *Laffenas, Barthelemy de*, valet de chambre to Louis XIII.

La Façon de faire et semer la Graine de Mûriers, les élever et replanter, gouverner les Vers à Soie au Climat de France. Paris, in 12mo.

1607. *Vinet, Elie*, a learned professor at Bourdeaux, author of a work on land surveying.

La Maison Champêtre et Agriculture. Paris, in 4to

1663. *Patin, Charles*, son of a physician of that name.

Traité des Tourbes Combustibles. Paris, in 4to.

1703. *Liger, Louis*, born 1658, died in 1717. In the latter part of his life he seems to have been a bookseller, or an author by profession.

1. Dictionnaire Général des Termes propres à l'Agriculture, avec leurs Définitions et Etymologies. Paris, in 12mo.

2. La Nouvelle Maison rustique, ou Economie Générale des Biens de la Campagne. Paris, 2 vols. in 4to. 1755.

3. L'Economie Générale de la Campagne, ou Nouvelle Maison rustique. 1762.

4. Nouveau Système d'Agriculture. 3 vols. in 8vo. 1775.

1749. *Boucher d'Argis, Antonine Gaspard*, advocate and author of some works on jurisprudence.

Code Rural, ou Maximes et Réglemens concernant les Biens de la Campagne, 2 vols.

1749. *Réaumur, René, Antoine Ferchault, sieur de*, a learned naturalist, born at Rochelle in 1683, died in 1757.

Art et Pratique de l'Art de faire éclore, en toutes Saisons, des Oiseaux Domestiques de toutes Espèces. Paris, Imprim. Royale, 3 vols. in 12mo, avec fig.

1750. *Hamel, Du Monceau, Henry Lewis du*, a famous French writer on Rural Economy and Vegetable Physiology, was born at Paris, 1700; died there 1782.

1. Traité de la Culture des Terres. Par. 6 vols. 12mo.

2. Elémens d'Agriculture. Par. 1764, 2 vols. 12mo.

3. Traité de la Conservation des Graines, et en particulier du Froment. Par. 1754. 12mo.

4. Traité des Arbres et Arbustes, qui se cultivent en France, en pleine Terre. Par. 1755, 2 vols. 4to.

5. Traité complet des Bois et des Forêts. Par. 1758, 6 tom. 4to.

6. Des Semis et Plantations des Arbres, et de leur Culture. Par. 1760. 4to.

7. Histoire d'un Insecte qui devore les Grains de l'Augoumois. Par. 1762. 12mo.

8. De l'Exploitation des Bois, ou Moyen de tirer Parti des Taillis demi Futayes et hautes Futayes. Par. 1764. 2 vols. 4to.

9. Mémoire sur la Garence et sa Culture, in 4to. 1765.

10. Du Transport, de la Conservation, et de la Force du Bois. 1767. 4to.

1751. *Desbois, Francis Alexander Aubert de la Chesnaie*, a laborious Dictionary-maker; was born at Ernée in the Maine, 1699; died 1784.

Dictionnaire d'Agriculture. 2 vols. 8vo.

1755. *Blavet*, librarian to the Prince of Conti.

Essai sur l'Agriculture Moderne. Paris, in 12mo.

1755. *Tillet, du*, of Bourdeaux, a zealous agriculturist, author of several works. He died in 1791.

Dissertation sur la Cause qui corrompt et noircit les Graines de Blé dans les E'pis, in 4to.

1756. *Hastfer, F. W.*

Instruction sur la Manière d'élever et de perfectionner les Bêtes à Laine. Paris, 2 vols. in 12mo.

1760. *Alletz, Pons Augustin*, an advocate, and indefatigable compiler.

L'Agronomie, ou Dictionnaire portatif du Cultivateur, 2 vols. in 8vo.

1760. *Buch'oz, Pierre Joseph*, a physician, and member of several societies; born at Metz in 1731, died in great distress at Paris in 1807. He wrote above three hundred volumes relative to medicine, agriculture, the veterinary art, and natural history. A plant (*Buchoziana*) was named after him by L'Héritier.

1. Lettre sur la Méthode de s'enrichir promptement et de conserver sa Santé par la Culture des Végétaux, in 8vo.

2. Lettre sur le Blé de Smyrne, in 8vo. 1768.

3. Histoire des Insectes nuisibles à l'Homme, aux Bestiaux, &c. in 12mo. 1781.

4. Manuel usuel et économique des Plantes, contenant leur Propriétés pour les Usages économiques. Paris, in 12mo. 1782.

5. Histoire des Insectes utiles à l'Homme, aux Animaux, et aux Arts. Paris, in 12mo. 1785.

6. Traité de la Pêche, ou l'Art de soumettre les Poissons à l'Empire des Hommes, précédé de l'Histoire Naturelle de ces Animaux, in 12mo. 1786.

7. Dissertation sur la Betterave et la Poirée, leur Culture, Méthode pour en tirer du Sucre, &c. fol. 1787.

8. Dissertation sur le Cochon, in fol. 1789.

9. Dissertation sur le Lin de Sibérie, in fol. 1789.

10. Dissertation sur la Taupe; les Moyens de la prendre, in fol. 1790.

11. Dissertation sur le Tirage de la Soie, in fol. 1792.

12. Manuel Tabacal et Sternutatoire des Plantes, ou Traité des Plantes qui sont propres à faire éternuer, avec la Manière de cultiver le Tabac, de le préparer, et de juger de ses bons Effets dans la Société, in 8vo. 1799.

13. Manuel Territorial des Plantes, in 8vo. 1799.

14. Manuel Vétérinaire des Plantes, in 8vo. 1799.

15. Mémoire sur le Blé de Smyrne, sur le Blé de Turquie, le Millet d'Afrique, et la Poirée d'Abyssinie, Plantes Alimentaires pour l'Homme; in 8vo. 1824.

16. Mémoire sur la Manière de former des Prairies Naturelles, in 8vo. 1805.

1760. *Turbilly, Louis François Henri de Menon*, Marquis de, a proprietor in Anjou, who had been in the army, but who retired to his estates and broke up and improved a number of acres, of which he published an account, well known at that time in England. Arthur Young, when in France in

1787, was anxious to visit the Marquis; but after, with difficulty, finding out the estate of Turbilly, he found the Marquis had died in 1776, having ruined himself by establishing a pottery. There is a very interesting account of this visit in *Young's Tour*, part I. p. 294. et seq.

1. Mémoire sur les Défrichemens, in 12mo.

2. Pratique des Défrichemens. Paris, in 12mo. 1701.

1761. *Guillot, Julien Jean Jacques*.

Discours sur les Branches d'Agriculture les plus avantageuses à la Province de Normandie.

1761. *Neuve-Eglise, Louis Joseph Bellepière de*, an officer in the army.

1. L'Agronomie, ou Corps complet des Principes de l'Agriculture, &c. 8 vols. in 8vo.

2. Boussole Agronomique, ou le Guide des Laboureurs, in 8vo. 1762.

1762. *Desplaces, Laurent Benoist*.

1. Préservatif contre l'Agronomie, ou l'Agriculture réduite à ses vrais Principes. Paris, in 12mo.

2. Histoire de l'Agriculture ancienne, extraite de l'Histoire Naturelle de Pline, avec des Eclaircissemens et des Remarques. 12mo. 1765.

1762. *Despommiers*.

L'Art de s'enrichir promptement par l'Agriculture. Paris, 12mo.

1762. *Lafaille, Clement*, advocate, and member of several societies.

1. Mémoire sur les Moyens de multiplier aisément les Fumiers dans le Pays d'Aunis.

2. Essai sur l'Histoire naturelle de la Taupe; sur les différens Moyens qu'on peut employer pour la détruire. La Rochelle, in 12mo, fig. 1768.

1762. *L'Etang de la-Salle, Simon Philibert de*, of Rheims, a lawyer.

Des Prairies artificielles, ou Moyens de perfectionner l'Agriculture dans toutes les Provinces de France, surtout en Champagne, par l'Entretien et le Renouveau de l'Engrais; avec un Traité sur la Culture de la Luzerne, du Tréfle, et du Sainfoin, et une Dissertation sur l'Exportation du Blé. Paris. 8vo.

1763. *Barthex de Marmorières*, an officer, secretary of embassy, and member of various societies.

Mémoires d'Agriculture, &c. 8vo.

1763. *Duvergé*, a physician of Tours.

Analyse chimique des Terres de la Province de Touraine, des différens Engrais propres à les améliorer, et des Semences convenables à chaque Espèce de Terre. Tours. 8vo.

1763. *François, Nicholas*, de Neufchâteau, member of the Institute, the Senate, &c., a distinguished member of the Paris Agricultural Society, and author of numerous papers in their memoirs.

1. Avis aux Cultivateurs et Propriétaires de Troupeaux, sur l'Amélioration des Laines. Paris. 8vo. an. vii.

2. Essai sur les Moyens de tirer le Parti le plus avantageux de l'Exploitation d'un Domaine borné, ou Système d'Agriculture pour les petits Propriétaires. Neufchâteau. 8vo. 1790.

3. Essai sur la Nécessité et les Moyens de faire entrer dans l'Instruction publique l'Enseignement de l'Agriculture; lu à la Société d'Agriculture de la Seine, &c. 8vo. 1802.

4. Rapport sur le Perfectionnement des Charrues, fait à la Société Libre d'Agriculture du Département de la Seine. Paris, 8vo.

5. Répertoire universel et raisonné d'Agriculture. Paris, 12mo. 1804.

1763. *Préfontaine*.

Maison Rustique à l'Usage des Habitans de la Partie de la France équinoxiale, connue sous le Nom de Cayenne. 8vo.

1763. *Thierat*. An officer of the royal forests, author of some tracts on gardening.

Instructions familières en forme d'Entretien sur les principaux Objets qui concernent la Culture des Terres. Paris. 12mo.

1764. *Bertrand, Elie*, a clergyman at Orbe, in Switzerland, and member of various societies.

1. Traité de l'Irrigation des Prés. 12mo.

2. Elémens d'Agriculture, fondés sur les Faits et les Raisonnemens, à l'Usage du Peuple de la Campagne. 8vo. 1774.

1764. *Bertrand, Jean*, brother of Elie B.

De l'Eau relativement à l'Economie Rustique, ou Traité de l'Irrigation des Prés. Lyons, 12mo.

1764. *Dupont*, of Vemouins, formerly a member of the constituent assembly.

1. Lettre sur la Différence qui se trouve entre la Grande et la Petite Culture. Soissons, 8vo.

2. Journal d'Agriculture, &c. 8vo. 1766.

1765. *Chambray, Louis*, Marquis de, an amateur apple grower and ciderist.

L'Art de cultiver les Pommiers, les Poiriers, et de faire les Cidres, selon l'Usage de Normandie. Paris, 12mo.

1765. *Sarcey-de-Sutières*, an officer in the army, and "gentilhomme servant" of the king.

1. Agriculture expérimentale à l'Usage des Agriculteurs, Fermiers, et Laboureurs. Paris, 12mo.

2. Cours complet d'Agriculture, ou Leçons périodiques sur cet Art. 1788.

1768. *Lesbros-de-la-Versane, Louis*, of Marseilles.

Traité de la Garence, ou Recherches sur tout ce qui a Rapport à cette Plante. 8vo.

1768. *Marchand, Jean Henri*.

Les Délassemens Champêtres. 2 vols. 12mo.

1768. *Palteau, Guillaume Louis Formanoir de*, of Sens, author of a work on bees.

Observations et Expériences sur diverses Parties d'Agriculture. Sens. 8vo.

1769. *Chanvallon*, a clergyman.

Manuel des Champs ; ou Recueil choisi, instructif, et amusant de tout ce qui est le plus Utile et le plus Nécessaire pour vivre avec Aisance et Agrément à la Campagne. Paris. 12mo.

1769. *Le Brève*.

Essai sur le Haras ; ou Examen des Moyens propres pour établir, diriger et faire prospérer les Haras : suivi d'une Méthode facile de bien examiner les Chevaux que l'on veut acheter. 8vo, fig.

1769. *Rigaud de l'Isle*, of Crest, in Dauphiny.

Mémoire sur la Culture de l'Espargette, ou Sainfoin. Paris. 8vo.

1769. *Sieuvé*.

1. Mémoire et Journal d'Observations sur les Moyens de garantir les Olives de la piqûre des Insectes et nouv. Méthode pour en extraire l'Huile plus abondante par l'Invention d'un Moulin domestique, avec la Manière de la garantir de toute Rancissure. Paris, 12mo.

2. Mémoires sur diverses Constructions en Terre ou Argile, propres à faire jouir les petits Ménages de l'Economie des combustibles. Poitiers, 8vo. 1804.

1770. *Amiot, Le P.*, missionary at Pekin.

Reflexions sur l'Agriculture, et sur ceux qui s'y consacrent : tirées de l'Éloge de la Ville de Moukden et de ses Environs. Poème composé par Kien-Long, Empereur de la Chine et de la Tartarie, actuellement régnant, traduit en Français par le P. Amiot, et publié par M. Deguignes, Membre de l'Académie Royale des Inscriptions et Belles Lettres, et Professeur des Langues Orientales au Collège Royale. Paris, 8vo. Cet ouvrage est curieux sous plus d'un rapport.

1770. *Beaunié, Antoine*, an eminent French chemist, was born at Senlis, 1728 ; died 1805.

Mémoire sur les Argiles ; ou, Recherches sur la Nature de Terres les plus propres à l'Agriculture, et sur les Moyens de fertiliser celles qui sont Stériles. Paris, 8vo.

1770. *Ricin*.

Encyclopédie Economique, ou Système général d'Economie rustique, contenant les meilleures Pratiques pour fertiliser les Terres, la Conservation des Grains, &c. ; par quelques Membres de la Société d'Agriculture de Berne. Yverdon, 16 vols. 8vo.

1770. *Rozier, François*, born in Lyons, 1734, and killed there on the 29th September 1793, during the siege of that city, by a bombshell, which buried his shattered remains in the ruins of the apartment which he occupied ; he began his career as an author, by writing in the *Journal de Physique et d'Histoire Naturelle*, of which Gauthier Dagoty was editor. He next occupied himself with his *Agricultural or Rural Dictionary*, the work by which he is chiefly known. He cultivated a farm near Bezières, which Arthur Young went to see when on his tour in France in 1787 ; but the Abbé had left it on account of the Bishop of Bezières, who kept a mistress somewhere near, and for his more commodiously visiting her, got a road made across the farm at the expense of the province. This occasioned a quarrel between the Abbé and the Bishop, which ended in the former being obliged to quit his farm. The Abbé, like all other men who depart from common practices, was looked on as a fanciful and wild cultivator ; and, because he paved his stables and cow-houses, it was reported by his neighbours that he paved his vineyard. He wrote a great many works, chiefly on agriculture.

1. L'Art du Magon piseur, extrait du Journal d'Observations sur la Physique, in 12mo.

2. Traité de la meilleure Manière de cultiver la Navette et le Colza, et d'en extraire une Huile Dépouillée de son mauvais Goût et de son Odeur désagréable. Paris, in 8vo. 1774.

3. Cours Complet d'Agriculture, Théorique, Pratique, Economique, etc. ; ou Dictionnaire universel d'Agriculture. 12 vols. in 4to. 1796.

1773. *Bexon, Gabriel Leopold Charles Ame*, a French miscellaneous writer, was born at Remiremont, 1748 ; died at Paris 1784 : he had a great turn for Natural History, and assisted Buffon in the latter volumes of his great work.

1. Le Système de la Fertilisation, 8vo.

2. Catéchisme d'Agriculture, ou Bibliothèque des Gens de la Campagne. 1773. 12mo.

1773. *Trother*.

L'Art de fertiliser les Terres, et de préserver de la Gelée, commodément et à peu de Frais, les Arbres et Arbrisseaux, les Vignes, &c. Méthode d'Education nationale et particulière. Paris. 3 vols. in 8vo.

1774. *Lerouge*, a friar of the order of Citeaux, in the abbey of Trisay.

Principes de Cultivateur, ou Essai sur la Culture des Champs, &c. avec un Traité abrégé des Maladies des Cultivateurs, de leurs Bestiaux, et des Remèdes pour les guérir. 2 vols. in 12mo.

1778. *Bulliard*, died at Paris in 1793.

Avicéptologie Française ; ou Traité général de toutes les Ruses dont on peut se servir, pour prendre les Oiseaux qui sont en France. Paris, in 12mo.

1779. *Ameithon, Hubert Pascal*, a librarian in Paris, and member of the legion of honour.

Journal d'Agriculture, &c. depuis Janvier. 1779 ; jusqu'en Décembre, 1785. Paris. 15 vols. in 12mo.

1779. *Maupin*, valet de chambre to the queen of Louis XVI.

1. L'Art de la Vigne, contenant une nouvelle Méthode économique de cultiver la Vigne. In 8vo.

2. Avis sur la Vigne, les Vins et les Terres. In 8vo. 1786

3. Almanach, ou Manuel des Vignerons de tous les Pays. Paris, in 8vo. 1789.

1780. *Bouthier*, advocate at Vienne in Dauphiny.

Le Citoyen à la Campagne, ou Réponse à la Question : quelles sont les Connaissances Nécessaires à un Propriétaire qui fait valoir son Bien pour vivre à la Campagne d'une Manière utile pour lui et les Paysans qui l'environnent ; dans le Cas où les Propriétaires ne demeurent point dans leurs Biens, quelles seraient également les Connaissances Nécessaires pour que les Curés, indépendamment de leurs augustes Fonctions, pussent être utiles à leurs Paroissiens. Genève, in 8vo.

1780. *Copineau, Abbé*.

Ornithologie artificielle. Paris, in 12mo. avec fig.

1780. *Mallet, Robert Xavier*, author of various works on gardening and rural subjects.

Précis Élémentaire d'Agriculture, &c. Paris, in 12mo. an. iii.

1781. *Parmentier, Antoine Augustin* ; born 1737, at Montdidier, in the department of La Somme, one of the most distinguished chemists and careful philosophers which have appeared in France ; author of a great number of works, and co-operator in many others, as the *Annales de Chimie, Nouveau Cours d'Agriculture* : he is mayor of Enghien, and has a small garden there, said by some to be more richly stocked with rare plants than any other in Europe of its size. (See *Encyc. of Gard.* p. 1119.)

1. Recherches sur les Végétaux Nourrissans, qui, dans les Temps de Disette, peuvent remplacer les Alimens Ordinaires. Paris, in 8vo.

2. Méthode facile pour conserver à peu de Frais les Grains et les Farines. In 12mo. 1784.

3. Observations sur les Moyens de maintenir et de rétablir Saubrité de l'Air dans la Demeure des Animaux Domestiques. an. xii.

4. Instruction sur les Moyens de rendre le Blé Moucheté propre à la Semence. Imp. roy. 1785.

5. Mémoire sur la Conservation et l'Usage des Blés de Turquie. Bordeaux, in 8vo. 1785.

6. Mémoire sur les Semailles. 1790.

7. Mémoire sur la Nature et la Manière des Engrais. 1791.

8. Mémoire sur les Clôtures.

9. Traité sur les Pommes de Terre, in 8vo. 1795.

10. Avis sur la Culture et les Usages des Pommes de Terre, in 8vo.

11. Traité du Mais, in 12mo.

1782. *Berthelot*, engineer to Louis XVI.

La Mécanique appliquée aux Arts, aux Manufactures, à l'Agriculture et à la Guerre. Paris, 2 vols. bound, in 4to, fig.

1782. *Cadet de Vaux, Antoine Alexis*, a distinguished patriot, founder of various useful institutions, and author of many projects for the public advantage, which have been carried into effect with success ; author of, and co-operator in, many economical publications.

1. Avis sur les Blés germés, in 8vo.

2. Bibliothèque des Propriétaires ruraux, Journal d'Economie Rurale et Domestique ; par une Société de Savans et de Propriétaires.

1782. *Parmentier, Deyeux*, and others. See 1781. Bibliothèque Physico-Economique, instructive, et amusante, à l'Usage des Villes et de Campagnes. (Paris, published monthly) 12mo. 68 vols. to 1825.

1784. *Dumont, Courset*, of Boulogne, where he cultivates his own estate of Courset, and has published a useful gardening work. (*Encyc. of Gard.* p. 1121. A. D. 1802.)

Mémoires sur l'Agriculture du Boulonnais, et des Cantons Maritimes voisins. Boulogne, in 8vo.

1785. *Chabert, Philippe*, inspector general of veterinary schools, and member of the legion of honour.

1. Instruction sur la Manière de conduire et gouverner les Vaches Lactières, in 8vo.

2. Altération du Lait de Vache, désignée sous le Nom de Lait bleu, in 8vo. 1805.

3. D'une Altération du Lait de Vache, &c. Paris, in 8vo. 1805.

1786. *Servières, B. De*.

Instruction sur la Manière de cueillir les Feuilles des Arbres, de les conserver et de les donner à manger aux Bestiaux ; publiée par Ordre du Roi. In 8vo.

1787. *Amoureux*, a physician at Montpellier.

1. Mémoire sur les Haies destinées à la Clôture des Prés, des Champs, des Vignes, et des Jeunes Bois. Paris, in 8vo.

2. Mémoire sur la Nécessité et les Moyens d'améliorer l'Agriculture dans le District de Montpellier, Avignon, &c. In 8vo.

1787. *Broussonnet, Pierre Marie Auguste*, member of the legislative assembly, of the commission of monuments, and author of a number of papers in the Memoirs of the Paris Agricultural Society.

1. Année rurale, ou Calendrier à l'Usage des Cultivateurs. Paris, 2 vols. in 12mo.

2. Feuille du Cultivateur. 8 vols. in 4to. 1788.

1789. *Cliquot, Blevache*, of Rheims, inspector of manufactures and commerce.

L'Ami du Cultivateur, ou Essais sur les Moyens d'améliorer en France la Condition des Laboureurs, des Journaliers, des Hommes de peine, vivant dans les Campagnes, et celle de leurs Femmes et de leurs Enfants. Paris, 2 vols. in 8vo.

1789. *Varenne, de Fenille, P. C.*, born at Bresse, and condemned to die by the revolutionary tribunal at Lyons in 1794, a zealous agriculturist, and much respected.

1. Observations, Expériences et Mémoires sur l'Agriculture, et sur les Causes de la Mortalité du Poisson dans les Etangs. Lyons, in 8vo, fig.

2. Observations sur les Etangs. 8vo. 1798.
3. Œuvres d'Agriculture de Varenne Fénelie, troisième et dernière Partie; Mémoires et Expériences sur l'Agriculture, et particulièrement sur la Culture et l'Amélioration des Terres, le Dessèchement et la Culture des Etangs et des Marais, la Culture et l'Usage du Marais, &c. 8vo. 1808.
1790. *Cotte, L.*, a priest of the oratory, author of some meteorological tracts.
1. Leçons élémentaires d'Agriculture, par Demandes et par Réponses, à l'Usage des Enfants, avec une Suite de Questions sur l'Agriculture. 12mo.
 2. Catéchisme à l'Usage des Habitans de la Campagne, sur les Dangers auxquels leur Santé et leur Vie sont exposés, &c. 12mo. 1799.
1790. *Dubois, J. B.*, author of an interesting memoir on the hay-forks made of the forked branches of the nettle tree in common use in the south of France.
- Feuille d'Agriculture, d'Economie Rurale et Domestique, à l'Usage des Propriétaires, &c. 4to.
1790. *Mayet, Etienne*.
- Mémoire sur les Moyens de mettre en Culture la plus Avantageuse les Terrains sec et arides, principalement ceux de la Champagne. 8vo.
1791. *Abeille, F.*, of Toulon.
- Observations de la Société d'Agriculture sur la Question suivante, proposée par le Comité d'Agriculture et de Commerce de l'Assemblée Nationale; l'Usage des Domaines congéables est-il utile ou non au Progrès de l'Agriculture? 8vo.
1791. *Lamoignon Malesherbes, Chrétien Guillaume*, a statesman, born at Paris, 1721; guillotined 1793: he was esteemed a patriot, a man of correct morals and elegant taste.
- Idees d'un Agriculteur Patriote sur le Défrichement des Terres incultes, sèches et maigres, connues sous le Nom de Landes, Garrigues, Gâtines, Friches, &c. 8vo.
1791. *Paillet*.
- Instructions sur la Plantation, la Culture, et la Récolte du Houblon. 8vo. A translation from the English.
1791. *Tessier, Henri Alexandre*, professor of agriculture and commerce in the central schools: he has paid great attention to the Merino breed of sheep, and the Angora variety of goat, of which government has put a large stock under his care.
1. Avis aux Cultivateurs, sur la Culture du Tabac en France. Publiée par la Société Royale d'Agriculture. Paris, in 8vo.
 2. Journal d'Agriculture à l'Usage des Habitans de la Campagne. 8vo. 1791.
 3. Annales de l'Agriculture Française, par MM. Tessier and Box. 12 numbers annually, amounting now (1850) to several volumes 8vo.
 4. Instruction sur les Moyens de détruire les Rats des Champs et les Mulots: publiée par Ordre du Ministre de l'Intérieur. 8vo.
 5. Mémoire sur l'Importation à France des Chèvres à de Duvet Cachemere. 8vo, pp. 32. Paris, 1819.
1792. *Cointereaux, François*, an architect, but more occupied as an author.
1. Architecture Rurale, &c. Paris, in 8vo.
 2. Cours d'Architecture Rural Pratique, &c. 8vo, avec figures, 1792.
 3. Les Erreurs de mon Siècle sur l'Agriculture, 1793.
 4. Almanach perpétuel des Cultivateurs. Paris, in 12mo. 1794.
 5. Nouveau Traité d'Economie Rurale. 8vo. 1803.
 6. Des nouvelles Bergeries, de ce qui les constitue bonnes et très salubres. 8vo. 1805.
 7. Des nouvelles Dispositions et Constructions des Faisanderies, et des Moyens de multiplier les Faisins, avec la Manière d'élever les Oiseaux, &c. 1805.
 8. Ecole d'Architecture Rurale. Lyons, in 8vo, an iv.
 9. La Ferme. In 4to.
 10. Nouveaux Murs de Terrasses solides et durables, et qui dispensent de cette Profusion de Matériaux qu'on y emploie: Ouvrage utile à tous les Pays; principalement aux Architectes, Ingénieurs, Maçons, et tous Propriétaires, Agens, et Fermiers. 8vo. 1805.
 11. Traité de l'ancien Pisé des Romains, &c. Traité qui indique les Qualités des Terres propres au Pisé, les Enduits, &c. Traité sur les Manufactures et les Maisons de Campagne. Traité qui enseigne le nouveau Pisé, la Manière de le faire lors des Pluies, des Neiges et des Frimas. 8vo.
1794. *Belair, A. P. Julienne de*, an engineer, formerly in the service of Holland and Prussia; he has written also on military subjects.
- Mémoire sur les Moyens de parvenir à la plus grande Perfection de la Culture et de la Suppression des Jachères. 8vo.
1794. *Bertrand*, inspector-general of roads and bridges.
- Avis important sur l'Economie Politique et Rurale des Pays de Montagnes, et sur la Cause et les Effets Progressives des Torrens, &c. Paris, in 8vo.
1794. *Fontalard, Jean François de*, of Lorraine.
- Principes raisonnés d'Agriculture, ou l'Agriculture démontrée par les Principes de la Chimie Economique, d'après les Observations de plusieurs Savans; Ouvrage traduit en Français, sur la Version Latine de Jean Gottschalk Valerius de Stockholm. Paris, an ii.
1794. *Huzard, Jean Baptiste*, veterinary surgeon of Paris, and member of several societies; Madame Huzard is the principal agricultural bookseller of Paris, as Harding was of London.
1. Essai sur les Maladies qui affectent les Vaches laitières des Environs de Paris. 8vo.
 2. Comte rendu à l'Institut de la Vente des Laines, et de 161 Bêtes du Troupeau National de Rambouillet, faite en prairial, an ix. 4to. 1801.
 3. Comte rendu à la Classe des Sciences, Mathématiques et Physiques, de l'Institut National des Améliorations qui se font

dans l'Établissement Rural de Rambouillet, et principalement de celle de Bêtes à Laine et de la Vente qui a eu lieu le 26 prairial, an xi. 4to. 1805.

1794. *Préaudeau-Chemilly Eugene*.

Des Haies considérées comme Clôtures; de leurs Avantages, et des Moyens de les obtenir. 8vo.

1795. *Cels, Jacques Martin*, member of the Institute, of the Paris agricultural society, &c.

1. Annuaire du Cultivateur, ou Répertoire universel d'Agriculture. 4to.

2. Avis sur les Récoltes des grains, publiée par le Conseil d'Agriculture du Ministère de l'Intérieur. Paris, in 8vo. an vi.

3. Instruction sur les Effets des Inondations et Débordemens des Rivières, relativement aux Prairies, aux Récoltes de Foins. 8vo. 1802.

1797. *Gilbert, François Hilaire*, born at Châtelle-rault, in 1737; died at St. Ildefonso, near Madrid, in 1800, when in search of a flock of merinos; a man of great zeal for agriculture.

1. Instruction sur les Moyens les plus propres à assurer la Propagation des Bêtes à Laine de Race d'Espagne, et la Conservation de cette Race dans toute sa Pureté: publiée par le Conseil d'Agriculture. 8vo.

2. Mémoire sur la toute du Troupeau National de Rambouillet, la Vente de ses Laines et de ses Productions disponibles. 4to. 1797.

3. Recherches sur les Espèces de Prairies artificielles qu'on peut cultiver avec le plus d'Avantage en France. Paris, in 12mo. 1799.

1798. *Barbé-Marbois*, of Metz, who filled various civil offices, and was a grand officer of the legion of honour.

1. Culture du Trèfle, de la Luzerne, et du Sainfoin. Metz, in 8vo.

2. La Richesse des Cultivateurs; ou Dialogues entre Benjamin Jachère et Richard Trèfle, Laboureurs, sur la Culture du Trèfle, de la Luzerne, et du Sainfoin. 8vo. 1803.

1799. *Lasteyrie, Charles Philibert de*, member of various literary, philosophical, and agricultural societies, an active patriot, and zealous philanthropist.

1. Traité des Bêtes à Laine d'Espagne; leur Voyages, la Tonte, le Lavage, et le Commerce des Laines, les Causes qui donnent la Finesse aux Laines: auquel on a ajouté l'Historique des Voyages que font les Moutons des Bouches-du-Rhône, et ceux du Royaume de Naples; l'Origine, le Succès, l'Etat actuel du Troupeau de Rambouillet, et les Moyens de propager et de conserver la Race Espagnole dans toute sa Pureté. 8vo.

2. Histoire de l'Introduction des Moutons à Laine fine d'Espagne dans les divers Etats de l'Europe, et au Cap de Bonne-Espérance; Etat actuel de ces Animaux; différentes Manières dont on les élève, les Avantages qu'en retirent l'Agriculture, les Fabriques, et le Commerce. 2 vols. in 8vo. 1803.

3. Mémoires sur différens Points d'Economie Rurale. Paris, an viii.

4. Du Cotonnier et de sa Culture, ou Traité sur les diverses Espèces de Cotonniers, sur la Possibilité et les Moyens d'acclimater cet Arbruste en France, sur sa Culture dans différens Pays, principalement dans le Midi de l'Europe, et sur les Propriétés et les Avantages Economiques, Industriels, et Commerciaux du Coton. Paris, in 8vo, avec Planch. 1808.

5. Collection de Machines, d'Instrumens, &c. employés dans l'Economie, Rurale, Domestique, et Industriale, d'après les Dessins faits dans diverses Parties de l'Europe. 2 vols. in 4to. 200 Planches avec Texte. Paris, 1820.

1800. *Ducouedic*, a great bee master.

Notice sur les Tourbières, et sur le Manière de les exploiter; avec l'Art d'en créer dans toutes les Propriétés Rurales, pour augmenter la Quantité des Engrais et des Combustibles. Isle of Vilaine. 8vo.

1800. *Fabre*.

Essai sur la Théorie des Torrens et des Rivières, contenant les Moyens les plus simples d'en empêcher les Ravages, d'en rétrécir le Lit, et d'en faciliter la Navigation. Paris, in 4to.

1801. *Dralet*, of Toulouse, Director of forests, member of several societies. In 1810, his *Molecatcher* had gone through nine editions. (*Bibliog Agronomique*, 315.)

L'Art du Taupier. 8vo.

1801. *Lacoste*, of Plaisance, professor of Natural History at Clermont-Ferrard, and afterwards of morals at Toulouse.

Quelques Observations concernant l'Agriculture dans les Montagnes du Département du Puy-de-Dôme. 8vo.

1802. *Daubenton, Jean Louis Marie*, born 1716, died 1799, co-operator with Buffon in the composition of his *Natural History*. "Buffon," says Cuvier, "only listened to his imagination, while Daubenton always dreaded the influence of that faculty of his mind."

Instruction pour les Propriétaires de Troupeaux, avec d'autres Ouvrages sur les Moutons et sur les Laines. A posthumous work. 8vo.

1802. *Fromage de Feugre, C. Michel F.*, veterinary professor of Alfort, and author of many works on his profession.

Des Chenilles, des Avoines, et des Moyens d'empêcher leur Ravages. Paris, 8vo.

1802. *Pietet, Charles*, of Geneva, one of the conductors of the *Bibliothèque Britannique*.

1. Faits et Observations concernant la Race des Mérinos d'Espagne à Laine superfine, et les Croisemens. 8vo.

2. Quelques faits concernant la Race des Mérinos d'Espagne, à Laine superfine. Genève, in 8vo, fig. an viii.

3. Comparaison de trois Charrues. 8vo, pp. 128. avec planche. Genève, 1825.

1802. *Rauch, F. A.*, engineer of roads and bridges.

Harmonie hydro-végétale et Météorologique, ou Recherches

sur les Moyens de recréer, avec nos Forêts, la Force des Températures et la Régularité des Saisons par des Plantations raisonnées. 2 vols. in 8vo.

1803. *Depradt, D.*, archbishop of Malines, almoner to Nap. Bonaparte at Warsaw, and since the restoration of the Bourbons, author of various political works, which have excited considerable interest.

1. De l'Etat de la Culture en France, et de ses Améliorations. 2 vols. in 8vo.

2. Voyage Agronomique en Auvergne. Paris, 8vo. 1828.

1803. *Dourches, Charles*, member of several societies.

1. Traité des Prairies et du leurs Irrigations, in 8vo.

2. Aperçu Général des Forêts. 2 vols. in 8vo. an xiii.

1803. *Sinety, André Louis Esprit*, member of several societies.

L'Agriculture du Midi, ou Traité d'Agriculture propre aux Départemens Méridionaux, &c. Marseilles, 2 vols. in 12mo.

1804. *Jacquin, M. E.*

Instructions sur l'Economie Rurale et Domestique aux Habitans des Campagnes: publiées par la Société d'Agriculture du Département des Deux-Sèvres. 8vo.

1805. *Aigoïn*, member of the Agricultural Society of Ivreé.

Mémoire sur l'Amélioration du Troupeau de Mérinos et de Bêtes à Laine indigènes établi à la Mandria de Chivas, Département de la Loire, et sur les Progrès d'Agriculture dans ce Domaine. In 8vo.

1805. *Tollard, Claude*, member of various societies, and who visited most parts of the Continent; afterwards a nurseryman near Paris, and finally a corn-merchant.

Traité des Végétaux qui composent l'Agriculture de l'Empire Française, &c. 12mo.

1806. *Bagot*, member of the Agricultural Society of the Seine.

1. Mémoire sur les Produits du Topinambour, comparés avec ceux de la Luzerne, et de plusieurs Racines légumineuses. Paris.

2. Annales de l'Agriculture Française, contenant des Observations et des Mémoires sur toutes les Parties de l'Agriculture.

1806. *Lullin, Ch. J. M.*

Des Prairies artificielles d'Été et d'Hiver; de la Nourriture des Brébis, et des Améliorations d'une Ferme dans les Environs de Genève. 2e edit. révisée et considérablement augmentée. Genève, 8vo, pp. 532.

1807. *Gaçon Dufour, Marie Armande Jeanne.*

Dictionnaire Rural Raisonné, dans lequel on trouve le Détail des Plantes Préservatives et Curatives des Maladies des Bestiaux.

1807. *Morel de Vindé*, peer of France, a proprietor of a beautifully situated estate near Marly, in the neighbourhood of Paris.

1. Mémoire sur l'Exacte Parité des Laines Mérinos de France et des Laines Mérinos d'Espagne, suivi de quelques Eclaircissemens sur la vraie Valeur que devraient avoir dans le Commerce les Laines Mérinos Françaises. 8vo.

2. Quelques Observations pratiques sur la Théorie des Assolemens. Paris, 8vo. 1822.

3. Essai sur les Constructions Rurales Economiques, contenant leurs Plans, Coupes, Elevations, Détails, et Dévis établis aux plus bas Prix possibles. (Les Détails de Constructions et Dévis par A. L. Lussou, Architecte.) Paris, in folio, pp. 40. avec 36 Planches, 1822.

1807. *Prevost, Bénédicte.*

Mémoire sur la Cause immédiate de la Carie ou Charbon des Blés, et de plusieurs autres Maladies des Plantes, et sur les Préservatives de la Carie. Montauban. 8vo.

1809. *Calvel, Etienne*, member of the Museum of Toulouse, and of other societies, author of various scientific works on rural subjects.

Mémoire sur l'Ajonc, ou Genêt épineux considéré sous le Rapport de Fourrage, de l'Amendement des Terres Stériles, et de Supplément au Bois. Paris, in 8vo.

1812. *Thouin, M. André*, Le Chevalier de, professor of culture in the University of Paris; author of various memoirs on gardening and agriculture, inserted in the French encyclopædias, dictionaries, and periodical works, and in the transactions of their learned bodies; an excellent man, and esteemed one of the first gardeners in Europe. He died in 1824. (See *Encyc. of Gard.* p. 1117.)

Description de l'École d'Agriculture Pratique du Museum d'Histoire Naturelle. 4to.

1815. *Delabergerie, J. B. R.*, membre de plusieurs sociétés savantes nationales et étrangères; ancien préfet.

Histoire de l'Agriculture Française, considérée dans ses Rapports avec les Loix, les Cultes, les Mœurs, et le Commerce; précédée d'une Notice sur l'Empire des Gaules et sur l'Agriculture des Amiens. Paris. 8vo.

1816. *Bonnemain*, a physician, member of several societies.

Observations sur l'Art de faire éclore et à élever la Volaille sans le Secours des Poules, ou Examen des Cases qui ont pu empêcher aux diverses Tentatives qui ont été faites en Europe, pour imiter les Egyptiens. Paris, in 8vo, pp. 56.

1816—1830. *Anon.*

Journal d'Agriculture d'Economie Rurale et des Manufactures du Royaume des Pays-Bas, &c. Brussels, 8vo, in monthly numbers.

1816. *Chatelain, le Chevalier*, a cavalry officer.

Mémoire sur les Chevaux Arabes; Projet tendant à augmenter et à améliorer les Chevaux en France; Notes sur les différentes Races qui doivent être préférées à ce sujet, &c. &c. Paris, 8vo.

1817. *Bornot, M. A.*, a notary at Savoisy.

Pratique Raisonnée de la Culture du Tréfle et de Sainfoin. Paris, 8vo, pp. 100.

1818. *Avrouin, Foulon*, mayor of Semblançay.

Essai sur les Défrichemens des Landes, et le Deséchement des Marais. Tours, 8vo, pp. 40.

1819. *Peyrouse, Baron Picot de La.*

A Sketch of the Agriculture of a District in the South of France. Translation with Notes. 8vo.

1819. *Villeneuve, Comte Louis de.*

Essai d'un Manuel d'Agriculture, ou Exposition du Système de Culture suivi pendant 19 ans dans le Domaine d'Hanterive, Commune de Cartres, Département du Tours. Toulouse, 8vo, pp. 908.

1819. *Yvast, A. Victor*, Member of the Institute, and one of the writers in the *Nouveau Cours d'Agriculture*, &c.

1. Excursion Agronomique en Auvergne, principalement aux Environs des Monts d'Or et de Puy-de-Dome; suivie de Recherches sur l'Etat, et l'Importance des Irrigations en France. Paris, 8vo, pp. 218.

2. Considérations générales particulières sur la Jachère et sur les meilleurs Moyens d'arriver graduellement à sa Suppression avec de grand Avantages. Imprimé par Ordre de la Société Royale et Centrale d'Agriculture. Paris, 8vo, pp. 220. avec Planches, 1822.

1829. *Audouin, Maurice.*

Exposé du Projet d'Etablissement d'une Ferme expérimentale dans chaque Département du Royaume. Paris, 8vo, pp. 8.

1820. *Crud, Le Baron E. V. B.*, the translator of Thær's works from the German.

Economie de l'Agriculture. Genève, 4to, pp. 414.

1820. *Deslandes.*

Elémens de l'Agriculture et des Sciences qui s'y rapportent, &c. Paris, 2 vols. 12mo, pp. 690.

1821. *Guillaume, Ch.*

Instrumens aratoires, inventés, perfectionnés, dessinés, et gravés. Par Ch. G. Paris, oblong folio, pp. 28. avec 12 Planches.

1821. *Lajons, M. de*, mayor of Atigat.

Abrégé élémentaire d'Agriculture Pratique, d'après les Principes de Rozier, Arthur Young, Duhamel, &c.: principes appliqués à la Nature du Solles Pyrenées, a sa Température, &c. Toulouse, 8vo, pp. 532. avec fig.

1822. *Adamson, Madame Aglaë.*

La Maison du Campagne. Paris, 3 vols. 12mo. pp. 1098.

1822. *Francès, Aimé.*

L'Art de la Stercoration, ou les Loisirs d'un Agriculteur Practicien retiré à la Campagne; Méthode pour fabriquer une Quantité immense de Fumiers qui dureront 8 Ans, tandis que les Fumiers ordinaires sont évaporés dans deux années. Toulouse, 8vo, pp. 43.

1822. *Morogues, Baron de.*

Essai sur les Moyens d'améliorer l'Agriculture en France, particulièrement dans les Provinces les moins riches, et notamment en Soulogne. Paris, 2 vols. 8vo, pp. 952.

1822. *Thiery, P. J.* (officier comptable du dépôt royal d'étalons de Strasbourg.)

Mémoire sur l'Amélioration des Chevaux en Alsace, par le Croisement des Races et l'Education, et particulièrement sur les Moyens de les préserver de la Cécité. Mémoire Couronné, &c. Strasbourg, 4to, pp. 160. 1822.

1822. *Polignac, Comte Charles de.*

Rapport au Roi sur les Troupeaux de pure Race, expliquant les Motifs et les Développemens des nouveaux Principes d'Administration pratiqués dans sons Etablissement Rural de Calvados. 8vo. Caen, 1822.

1823. *Chaptal*, Comte, a distinguished chemist and statesman, who cultivates a considerable part of his own estate.

La Chimie appliquée à l'Agriculture. Paris, 2 vo's. 8vo.

1823. *Bosc, Th.*, vice president de la Société d'Agriculture du Dents.

1. Rapport sur l'Emploi du Plâtre en Agriculture fait au Conseil Royal d'Agriculture. Paris, 8vo, pp. 108.

2. Traité élémentaire de Physique végétale appliquée à l'Agriculture. Paris, 1824. 8vo, pp. 110

1824. *Dubois, Louis.*

Cours complet et simplifié d'Agriculture et d'Economie Rurale et Domestique. Paris, 6 vols. 12mo.

1824—1830. *Mathieu de Dombasle, C. J. A.*

Annales Agricoles de Roville, ou Mélanges d'Agriculture, d'Economie rurale, et de Législation Agricole. Paris, 8vo, 5vols.

1824. *Dombasle, C. J. A. Matthieu de.* Directeur de l'Etablissement Agricole exemplaire de Roville, &c. &c.

Calendrier du Bon Cultivateur, ou Manuel de l'Agriculteur Practicien. Paris.

1824. *Mortemart-Boisse*, le Baron de.

Recherches sur les différentes Races des Bêtes à Laine de la Grande Bretagne, et particulièrement sur la nouvelle Race de Leicestershire. Paris, 8vo.

1824. *Polonçeau, M.*

Notice sur les Chèvres Asiatiques à Duvet du Cachemere, et sur un premier Essai tenté pour augmenter leur Duvet, et lui donner des Qualités nouvelles, &c. Paris, 8vo.

1825. *La Société d'Agriculture de Paris.*

Annuaire de la Société Royale et Centrale d'Agriculture, 8vo. (Continued Annually.)

1825. *Douette-Richardot, Nicolas*, et rédigé par Richardot l'aîné, juge de Paix à Verry, Département de la Marne.

De la Pratique de l'Agriculture; ou Recueil, &c. Paris, 1 vol. 8vo.

1825. *Legris*, geometrical engineer.

La Nouvelle Méchanique Agricole, &c. Paris, 8vo, deux planches.

1825. *Dubrunfaut, M.*

L'Art de fabriquer le Sucre de Betteraves. Paris, 8vo.

1825. *Ferussac, Baron de*, conductor.
Bulletin des Sciences Agricoles et Economiques. Paris, 8vo. Monthly Numbers.
1825. *Chabrol De Volvie, Comte de*, councillor of state, and prefect of the Seine.
Statistique des Provinces de Savone, d'Oneille, d'Acqui, et de Partie de la Provence de Mondovi, formant l'ancien Département de Montenotto. Paris, 2 vols. 4to, plates.
1825. *Chabonillé Dupetitmont, M.*, cultivator.
Manuel Pratique du Laboureur. Paris, 2 vols. 12mo.
1825. *Payen et Chevalier*, MM.
Traité de la Pomme de Terre. Paris, 8vo.
1825. *Pinteur*, senior butcher and syndic of the shambles of Paris.
Réflexions sur la Production et la Population des Bestiaux en France. Paris, 8vo.
1826. *Sénac, M.*, and the *Baron de Ferussac*.
Bulletin des Sciences Agricoles et Economiques. Paris, 8vo, in Monthly Numbers.
1826. *Gilbert, H. F.*, a distinguished agriculturist.
Traité des Prairies artificielles; ou Recherches sur les Espèces de Plantes qu'on peut cultiver avec le plus d'Avantage en Prairies artificielles, et sur la Culture qui leur convient le mieux. Paris, 1 vol. 8vo.
1826. *Pontier, P. H.*, senior, inspector of woods and waters.
Mémoire sur la Connoissance des Terres en Agriculture. Paris, 8vo.
1826. *Puvis, M. A.*
Essai sur la Marne. Bourg. 8vo.
1826. *Anon.*
Annuaire de la Société Royale et Centrale d'Agriculture. Paris, 12mo.

1826. *Anon.*
Essai sur les Associations Agricoles. Toulouse, 8vo. 1 leaf.
1826. *Lépineois, M. E. B. de.*
Petit Cours d'Agriculture, ou Manuel du Fermier, &c. &c. Paris, 8vo.
1826. *Paupaille, M.*, author of a Treatise on Chemistry in the *Encyclopédie Portative*.
Discours sur les Applications de la Chimie à l'Agriculture et à la Botanique. Pamph. 8vo.
1826. *Bard, C. P.*
Minéralogie Populaire; ou Avis au Cultivateurs et aux Artisans sur les Terres, les Pierres, les Sables, &c. Paris, 18mo.
1826. *Delpierre, Léocade.*
Nouveau Guide du Fermier. Châteauroux. Pamphlet, 18mo.
1826. *Un Jardinier Agronome.*
Annuaire du Jardinier et de l'Agronome, pour 1826. Paris, 18mo.
1828. *Légarré, J. D.*, Esq., editor.
The Southern Agriculturist, and Register of Rural Affairs; adapted to the Southern Section of the United States. Charleston. In 8vo Numbers, monthly.
1828. *Delpierre, Léocade.*
Manuel du Fermier. Paris, 18mo.
1828. *Anon.*
Mémoires d'Agriculture, d'Economie rurale et domestique: publiés par la Société Royale et Centrale d'Agriculture. Paris, 8vo, 1 vol.
1829. *Anon.*
Journal de la Société d'Agronomie pratique (auquel s'est réuni Le Journal des Jardins). Paris. In 8vo Numbers monthly.
1829. *Moleon, J. G. V. de*, cond.
Recueil Industriel, Agricole, et Commercial. Paris, 8vo monthly Numbers.

SUBSECT. 2. *Bibliography of German Agriculture*

7901. The *German agricultural works* are as numerous as those of the French, but chiefly translations, and these, for the most part, from the English. We have given a very limited selection, the German language being less generally understood than either the French or Italian. In forest management (*Forstwissenschaft*) the German bibliography is very rich; and it is chiefly these books, and descriptions of local practices, which can be of any interest to the British cultivator. The older German works in rural affairs are enumerated in Haller's *Bibliography*; and the modern ones, and new editions in Ersch's *Handbuch der Deutschen Litteratur*, and the *Leipsic Catalogues*, published annually. Thäer of Moeglin is decidedly the highest in repute as an author, and Sickler's *Deutsche Landwirthschaft*, a voluminous work, will give a general idea of every part of German husbandry

1578. *Heresbachius, Conradus*, counsellor to the Duke of Cleve; was born in 1508, died in 1576. He wrote various theological works, besides his *Rei Rusticæ*, libri iv., which was published in 1570, and his *Legum rusticarum et Operarum per singulos Menses digestæ*, in 1595. The former was translated by Barnaby Googe, of Lincolnshire, with the following title:—

Four Bookes of Husbandrie, containing the whole Art and Trade of Husbandrie, Gardening, Graffing, and Planting, with the Antiquitie and Commendation thereof. Newly Englished and increased by Barnebe Googe, Esquire. At London, 4to. 1578. Leaves 194, besides the Dedication, Epistle and Table at the beginning; and Olde English Rules in Verse for purchasing Lande, at the end.

His authorities extend from the Bible and doctors of the church, through the Greek and Roman writers, Homer, Cato, &c., to the moderns as low as Ruellius, Fuchsius, Matthiolus, Cardanus, and Tragus. He subjoins a list of his friends and others who assisted him. S. Nich. Malbee, M. Cap. Byngham, M. John Somer, M. Nicas. Yetzwert, M. Fitzherbert, M. Willi. Lambert, M. Tusser, M. Tho. Whetenhall, M. Ri. Deering, M. Hen. Brookhu 1 M. Franklin, H. King, Richard Andrews, Henry Denys, William Pratte, John Hatche, Philip Partridge, Kenworth Daforth.

The work is in dialogue. The persons are Cono, a gentleman retired into the country; Rego, a courtier; Metella, wife of Cono; and Hermes, a servant.

1591. *Colcrus, J.*
1. *Calendarium œconomicum et perpetuum*. Wittebergæ.
2. *Economix Pars prima; qua tractatur quemadmodum bonus Œconomus famulos suos regere debet et Bona sua augere potest per veras honestas Artes, et utilia Compendia circa Res domesticas, Agriculturam, Piscatum, Aucupia, Venationes et Vinearum Culturam*. Wittebergæ, 4to. 1593.

1592. *Porta, J. B.*
Villæ, lib. xiii. Francofurti, 4to.

1735. *Zeigerus, Antoine.*
Introductio rationalis ad Œconomiam et Artem perficiendæ Agriculturæ, in quâ Methodus exponitur Experien iâ confirmata Omnegenus Agrorum sine consueta Stercoratione fecundandi. 4to.

1754. *Eckhart, J. Gli. von.*
Experimental Oekonomie über das Animalische Vegetabilische, und Mineral Reiche, oder vollständige Haushaltungs- und Landwirthschaftskunst. Jena, 1754. 8vo.

1760. *Der Schwiczer.*
Gesellschaft in Bern Sammlung von Landwirthschaftlichen Dingen; oder Abhandlungen und Beobachtungen durch die ökonomische Gesellschaft in Bern gesammelt. Zurich, 8vo.

1762. *Wigand, J.*
Wohlerfahrner Landwirth; oder Anleitung wie der Landwirthschafts Oekonomie zu verbessern. Wien, 8vo.

1766. *Cramer, John Andrew*, died 1777.
Anleitung zum Forst-wesen. Braunsch. fol.

1766. *Dérieule.*
Mémoires de l'Agriculture en générale, et de l'Agriculture de Pologne en particulier. Berlin, 8vo.

1769. *Lüders, Ph. E.*
Grundriss einer zu errichtenden Ackerschule, in welcher die Landjugend zu einer richtigen Erkenntniss und Uebung im Landbau angeführt und zubereitet werden könne. Flensburg, 8vo.

1773. *Krunitz, J. G.*
Ökonomische technologische Encyclopädie, oder allgemeines System der Staats, Stadt, Haus, und Landwirthschaft in Alphabetischer Ordnung. Berlin, 8vo.

1775. *Albrecht, J. F. E.*
Zootomische und Physikalische Entdeckungen von der innern einrichtung der Bienen, besonders der art ihrer begattung. Gotha, 8vo.

1775. *Suckow, G. Adg.*
Abhandlung vom Nutzen der Chemie zum Behuf des bürgerlichen Lebens und der Oekonomie. Manheim, 8vo.

1779. *Borcke, H. A. Grafen*, Count de.
Account of the Management of his Estate of Stargordt, in Pomerania. Berlin, 4to.

1780. *Christ, J. I.*
Patriotische Nachrichten, &c.; or, Patriotic Accounts and Instructions concerning the profitable Culture of Tobacco, and more especially of that called Asiatic Tobacco. Franck. 8vo.

1781. *Rössig, Karl Glo.*, author of some works on gardening and forest management.

Versuch einer pragmatischen Geschichte der Oekonomie, Polizey und Cameralwissenschaften, seit dem 16 ten Jahrhundert, bis auf unsere Zeiten. Deutschland Leipzig, 8vo.

2. Die Geschichte, der Oekonomie der vorzüglichsten Länder und Völker der ältern mittlern und neuern Zeit in einem kurzen Entwürfe dargestellt. Leipzig, 8vo. 1798.

1784. *Hiltensbrand, Ant.*
Erste Aufangsgründe der zur Landwirthschaft nöthigen Mechanik. Wien, 8vo.

1784. *Hofmann, Gli. Bd. Freyherr von.*
Die Landwirthschaft für Herrn und Diener. Prag. 8vo.

1785. *Fischer, C. F. J.*
Geschichte des Deutschen Handels, der Schiffahrt, Fischerey, Erfindungen, Künste, Gewerbe, der Landwirthschaft. Polizey des Zoll-Münz- und Bergwesens, der Staatswirthschaft und des Luxus. Hanover, 2 vols. 8vo.

1786. *Hartig, Fr. Grafen von.*
Historische Untersuchung über die Aufnahme und den Verfall der Feldwirthschaft bey verschiedenen Völkern. Pr. g. und Wien, 8vo.

1786. *Bizhaub.*
Brevis Rei rusticæ Descriptio. Giessen, 12mo.

1790. *Hartiz, Georges Louis.*
Observations Historiques sur les Progrès et la Décadence de l'Agriculture chez différens Peuples. Vienne, 5 vols. 8vo.

1791. *Anon.*
Kleine Schriften zur Stadt- und Landwirthschaft von der ökonomischen Gesellschaft in Bern herausgegeben. Zurich, 8vo.

1791. *Nan, Bh. Seb.*
Theoretisch praktisches Handbuch für Oekonomie, Bergbaukunde, Technologie und Thierarzneywissenschaft (in Alphabetischer Ordnung) von einer Gesellschaft bearbeitet. Zurich, 8vo.

1792. *Bose, K. Ad. H. von.*
Katechetische Unterricht zum Feldbau oder freundschaftliche Gespräche über die vorzüglichsten Gegenstände der alten und neuen Landwirthschaft; nebst einem Anhang, wie die Wohn- und Wirthschaftsgebäude und kleinen Rittergütern und grossen Bauergütern bequem und wohlthätig anzulegen. Halle, 8vo.
1792. *Riem, J.*
1. Monathlich praktisch ökonomische Encyclopädie für Deutsche, oder zusammenhangender Lehrbegriff der gemeinnützigsten praktischen Wirthschaftskunde, &c. Leipzig, 8vo.
2. Modell Magazin für Oekonomen; oder Abbildungen und Beschreibungen der nützlichsten und bequemsten Geräthschaften, Werkzeuge und Geschirre für Haushaltung Landwirthschaft, Viehzucht, &c. Leipzig, 1802, 4to, mit Kupfern.
1794. *Stumpf, G.*
Biographie und Schicksale des ökonomisch cameralistischen Instituts zu Jena; mit den nöthigsten Documenten. Jena, 8vo.
1796. *Huber, Francis*, member of the Society of Natural Philosophy and Natural History of Geneva.
Nouvelles Observations sur les Abeilles, adressées à M. Charles Bonnet. Par. 12mo.
1796. *Zehmens, Cp. H. Adf. von.*
System der Landwirthschaft, nach physischen und chemischen Grundsätzen behandelt, und durch lange Erfahrungen geprüft. Leipzig, 8vo.
1797. *Fischer, H. L.*
Katechismus der Haushalt und des Ackerbaues zum Gebrauch in Schulen. Braunschweig, 8vo.
1797. *Krantz, Guillaume.*
De l'Agriculture comme Source principale du Bien-être et de la Prospérité d'une Nation. Vienne, 8vo.
1798. *Thaer, Alb.*, of the establishment of Mögeln in Prussia, one of the most enlightened German agriculturists, author of numerous works, all in high repute. (576.) He died at an advanced age, and deeply regretted by all who had the happiness of being his pupils, in 1829.
1. Einleitung zur Kenntniss der Englischen Landwirthschaft. Hanover, 8vo.
2. Vermischte Landwirthschaftliche Schriften aus der drey ersten Jahrgängen der Annalen der niedersächsischen Landwirthschaft, ausgewählt und anszugsweise in Ansehung der eignen Arbeiten verbessert. Hanover, 8vo. 1806.
3. Grundsätze der rationellen Landwirthschaft. Berlin, 4to. 1809.
4. Annalen der niedersächsischen Landwirthschaft herausgegeben von der Braunschweigischen Landwirthschafts Gesellschaft durch Alb. Thaer und J. Kr. Benecke. Zelle. 8vo. 1799.
1799. *Anton, K. Glo.*
Versuch einer Geschichte der deutschen Landwirthschaft von den ältesten Zeiten bis zu Ende des 15 ten Jahrhunderts. Görlitz, 8vo.
1800. *Rückert, G. Ch. Alb.*
Bemerkung über Thaers Einleitung zur Kenntniss der Englischen Landwirthschaft. Wien, 8vo.
1800. *Steindel, A. H. von.*
Bemerkungen über Thaers Schreiben, &c. Leipzig, 8vo.
1801. *Huber, P.*, of Lausanne, in Switzerland, and son of Francis, previously mentioned.
1. Memoirs concerning the Influence of the Air, and several gaseous Substances, on the Germination of various Kinds of Grain. Geneva, 8vo.
2. Recherches sur les Mœurs des Fourmis Indigènes. Par. 1810.
1802. *Costa, Ch.*
Essai sur l'Amélioration de l'Agriculture dans les Pays Montueux, et en particulier dans la Savoie. 8vo.
1802. *Eschenbach, Ch. Ghld.*
Kunstmagazin der Mechanik und technischen Chemie; oder Sammlung von Abbildungen und Beschreibungen erprobter Maschinen, zur Vervollkommnung des Ackerbaues, der Manufacturen und Fabriken. Leipzig, 4to.
1802. *Gotthard, J. Ch.*
Das Ganze der Landwirthschaft; ein Systematisches Lehrbuch für Oekonomen, so wie für jeden, der sich dieser Wissenschaft widmet. Mainz, 8vo.
1803. *Engel, Lud. Hm. Hs. von.*
Anwendung der Englischen Landwirthschaft auf die Deutsche und beide gegen einander gestellt nach Thaer's Einleitung. Leipzig, 8vo.
1803. *Hermbsstädt, Sgm. F.*
Archiv der Agricultur-Chemie, für denkende Landwirthe; oder Sammlungen der wichtigsten Entdeckungen, Erfahrungen und Beobachtungen in der Physik und Chemie, &c Berlin.
1803. *Weber, F. Bd.*
Handbuch der ökonomischen Litteratur; oder Systematische Anleitung zur Kenntniss der Deutschen ökonomischen Schriften, die sowohl die gesammte Land- und Hauswirthschaft, als die mit denselben verbundenen Hülfs- und Nebenwissenschaften angehen; mit Angabe ihres Ladenpreises und Bemerkung ihres Werths. Berlin, 8vo.
1804. *Richter, K. F.*
1. Chemisch Oekonomisches Taschenbuch für Wirthschaftsbeamte, oder Darstellung der chemischen Elementargesetze welche mit der Oekonomie in der engsten Verbindung stehen. Chemnitz und Leipzig, 8vo.
2. Historische, Tabellarische Darstellungen der in jedem Monate vorkommenden Landwirthschaftlichen Arbeiten: auf jedes Jahr anwendbar, für Rittergutsbesitzer, Pächter und Verwalter. Chemnitz und Leipzig, fol. 1804.
1805. *Siekler, F. Ch. L.*, son to the celebrated German pomologist, and author of some interesting gardening works. (See *Encyc. of Gard.* p. 1126.)
Le Spirodiphire, ou Char à planter le Blé, avec deux Planch. Paris, 8vo.
1808. *Fellenberg, Emmanuel*, of the celebrated agricultural establishment of Switzerland, already noticed. (350.)
1. Rapport à S. Ex. le Landamman et à la Diète des 19 Cantons de la Suisse, sur les Etablissements agricoles de M. Fellenberg à Hofwyl, par M. M. Heer, &c. Paris et Genève, 8vo.
2. Vues relatives à l'Agriculture de la Suisse, et aux Moyens de la perfectionner. Genève, 1808.
3. Anstalten der schweitzer Landwirthschaft und des zweckmässigsten Mittels sie zu vervollkommen. Carlsruhe, 8vo. 1809.
1808. *Escher, von Berg.*
Briefe über die Fellenbergische Wirthschaft zu Hofwyl. Zurich, 8vo.
1808. *Theress, Thdr.*
Theoretisch-Praktisches Handwörterbuch der gesammten Landwirthschaft; oder Anweisung zur Kenntniss, Behandlung und Benutzung aller Landwirthschaftlichen Gegenstände; als des Feld- und Gartenbaues, der Viehzucht, &c. Göttingen, 8vo.
1809. *Hoffmann, A.*
Ueber Fellenbergs Wirthschaft in Hofwyl; nebst Anmerkungen und eine Nachschrift von Alb. Thaer (aus den Annalen des Ackerbaues.) Berlin, 8vo.
1809. *Scheffold, L.*
Berichtigung des helvetischen National Rapports über die Landwirthschaftlichen Anstalten des Herrn Em. Fellenbergs zu Hofwyl. Erlangen, 8vo.
1809. *Trantman, Cp.*
Lehrplan der Landwirthschaft. Wien, 8vo.
1810. *Schönlentner, M.*
Nachrichten über die königliche Landwirthschaftsschule in Weihenstephan und über das dort eingeführte Thaersche Acker-system. Munchen, 8vo.
1824. *Voght, Baron von*, a proprietor and cultivator at Flotbec, on the Elbe, near Hamburg.
Meine Ansicht der Statik des Landbaues. Hamburg, 8vo.
1825. *Huber, M.*
Ueber die Urbarmachung des Flugsandes. Berlin, 8vo.
1825. *Anon.*
Württembergischer Correspondenz des Landwirthschaft Vereins. Vol. 8.
1825. *Franque, Dr.*
Die Lehre von dem Körperbau, &c. Wiesbaden, 8vo, 1 theil.
1825. *Schuster, J.*, and *M. Haberle*, professors in the University of Hungary.
De Stipa Noxa. Perth, 12mo.
1825. *Weidenkeller.*
Archiv für Pferdekentniss, &c. 8vo.
1825. *Leuchs, Char.*
Vollständige Anleitung zur Mästung der Thiere, &c. Nuremberg, 8vo.
1825. *Hazzi, M. de*, councillor of state.
Gekroante Preisschrift ueber Gueter-Arrondirung, &c. Munich, 8vo.
1825. *Schwertz, N.*, director of the Experimental Agricultural Institution of the King of Wirtemberg, author of some excellent works on the agriculture of the Netherlands and Alsatia.
Anleitung zum praktischen Ackerbau, &c. Stuttgart, 8vo.
1825. *Graffen, F. G.*
Auf Erfahrung gegründet Unterricht, &c. Leipsig, 8vo.
1825. *Reider, T.*
Das Ganze des Karden distelbaues. Nuremberg, 12mo.
1826. *Hazzi, M. de*, councillor of state of Bavaria, author of an Essay on the *Union of Detached Property*.
Vom Dünger als Lebens princip der Landwirthschaft, &c. Munich, pamph. 4to.
1826. *Wittmann and Denglaez*, superintendants of the domains of the Archduke Charles of Austria.
Landwirthschaftliche Hefte. Vienna. 3 sheets.
1826. *Ribbe, M.*, Professor in the University of Leipsic.
Das Schaaf und die Wolle, &c. Leipsic, 8vo.
1826. *Galb, L.*
Anleitung für der Landmann, &c. Trèves, pamph. 8vo.
1826. *Closen, Baron de.*
Die landwirthschaftliche Erziehungsanstalt in Gern. Munich, 8vo.
1826. *Metzger, J.*, gardener to the University of Heidelberg.
Europäische Cerealien, &c. Heidelberg, fol.
1826. *Anon.*
Loudon's Encyclopädie des Landwirthschaft, &c. Translated from the English. Weimar, 8vo.
1828. *Hazzi, M. von*, knight, councillor of state to the King of Bavaria, member of many societies; editor of the *Bavarian Agricultural Journal*, and author of various works. The father of agriculture and of agricultural schools in Bavaria.
Neuster Katechismus des Feldbaues, &c. Munich, 12mo.
1828. *Kops, M.*, professor of botany and rural economy at the University of Utrecht.
Etat de l'Agriculture dans le Royaume des Pays Bas pendant l'année 1825. The Hague, pamph. 8vo.
1828. *Wagner, J. Ph.*
Ueber Merinos-Schafzucht. Königsberg, Gr. 8vo. 7 plates
1829. *Elsner, J. G.*
Uebersicht der Europ. veredelten Schafzucht. Prague 2 theile, 8vo.

SUBJECT. 3. *Bibliography of Italian Agriculture.*

7902. *A number of Italian agricultural works* have been published; such as they are, perhaps more of them are original than of the books of the French or Germans, because the culture of other parts of Europe is but ill adapted for Italy. The vine, olive, mulberry, orange, and the irrigation of lands, have a good deal occupied the Italian writers. Ré may be reckoned their general and popular author, and his *Nuovi Elementi*, 4 vols. 8vo, 1815, and *Annali dell' Agricoltura*, &c. 22 vols. 8vo to 1814, will give a good idea of Italian husbandry and gardening, the two arts in that country being for the most part combined.

1471. *Crescentius, Crescenzo*, or *De Crescentiis*, was born at Bologna about 1233; died 1320.

1. *Opus Ruralium Commodorum, sive de Agricultura*, libri xii. Augsburg, fol.

2. *De Agricultura, Omnibusque Plantarum et Animalium Generibus*. Basil, 1558.

1496. *Bertochus, Dionysius*, of Bologna, who printed some very early works at Vicenza.

Scriptores de Re Rustica. This contains the Agricultural works of Columella, Varro, Cato, and also of Palladius, &c.

1546. *Alamanni, Luigi*.

La Coltivazione e gli epigrammi, colle Api di Gio. Rucellai, ed annotaz. Rome, 8vo.

1564. *Gallo, Agostino*.

1. *Le dieci giornate della vera Agricoltura, e Piaceri della villa: in Dialogo*. Bresc. ap. G. B. Bozzola. 4to.

2. *La Vinti Giornate dell' Agricoltura, e de' Piaceri della Villa*. Turin, 1579. 4to.

1622. *Soderini, Giovanvettorio, e Bernardo Davanzati*.

Coltivazione Toscana delle viti e d' alcuni alberi. Aggiuntovi Coltivazione degli Olivi, di Pietro Vettori. Firenze, 4to.

1628. *Castelli, Benedict*, an Italian mathematician, and the particular friend of Galileo, was born at Brescia, in the year 1577; died about 1640.

Treatise of the Mensuration of Running Waters; also, Letters and Considerations touching the Draining of Fens, Divisions of Rivers, &c. Translated by Thomas Salisbury. Lond. 1661. fol. Published at Rome in 1628.

1658. *Fanara, Vincenzo*.

L'Economia del Cittadino in villa. Roma, in 4to.

1718. *Borro, Alessandro del*.

Dimostrazioni e prove sopra l'Altivita, ed uso vantaggioso del Gran Coltro. Milano, in 4to, fig.

1736. *Aquino, Charles d'*.

Nomenclator Agriculturae. Romæ, in 4to.

1758. *Gavellus, Nicholas*.

Storia distinta, e curiosa del Tabacco, concernante la sua scoperta, la Introduzione in Europa, e la Maniera di coltivarlo, conservarlo, e prepararlo. Pesaro, 8vo.

1767. *Cattaneo, Giacomo*.

Della Idropisia de' Gelsi. Milano, in 8vo.

1772, or earlier. *Tarello, Camillo*.

1. *Ricordo d'Agricoltura colle note del Padre Scottoni*. Venezia, in 4to.

2. *Ricordo d'Agricoltura corredato d'Annotazioni da Paolo Sangiorgio*. Milano, 1816, in 8vo.

1776. *Canciana*.

Saggi sopra la Legislazione propria alle arti dell' Agricoltura. Udine, in 8vo.

1777. *Salvini, Gio*.

Istruzione al suo fattore di campagna, in cui si da una piena notizia di tutto ciò ch' appartiene alla maggior promozione dell' arte agraria, e suoi metodi, ec. Venezia, in 8vo.

1778. *Cantuni, Carlo Antonio*.

Istruzioni pratiche intorno all' Agricoltura, e tenuta dei Bigatti. Berg. in 8vo.

1778. *Castellet, Constans*.

Istruzioni circa il modo di coltivare i gelsi, di allevare i bachi da seta, e di filar le sete, con nuove applicazioni e riflessioni. Torino, in 8vo.

1778. *Bidet, M*.

Trattato sopra la coltivazione delle viti; del modo di fare i vini, e di governarli. Venezia, in 8vo, fig.

1780. *Bertrand*.

Elementi di Agricoltura, fondati sui fatti e sui raziocinii ad uso delle persone di campagna. Vicenza, in 8vo.

1780. *Carrera, Antonio*.

Dissertazione sull' Economia Rurale. Venezia, in 8vo.

1781. *Brugnone, Gio*.

1. *Trattato delle razze de' cavalli, col disegno della fabbrica della regia mandra di Chivasso, e quello dei pascoli e prati*. Torino, in 8vo, fig.

2. *Boometria, o sia della conformazione esterna del corpo delle bestie bovine, delle loro bellezze e difetti, e delle avvertenze da aversi nella loro compra*. Torino, 1802, in 8vo.

3. *Ippometria, o sia della conformazione esterna del Cavallo, dell' Asino e del Mulo, delle loro bellezze e difetti, e delle attenzioni da aversi nella loro compra*. Torino, 1802, in 8vo.

1785. *Amoretti*.

1. *Istruzioni pubblicate della Società Patriottica di Milano, intorno ad alcuni quesiti della medesima proposti per l' anno 1785*. 4to.

2. *Della coltivazione delle Patate, e loro uso*. Milano, 1801, in 8vo, fig.

3. *Delle Torbiere esistenti nel dipartimento d'Olonza e limitrofi, e del loro vantaggi ed usi*. Milano, 1807, in 4to.

4. *Coltivazione delle Api nel Regno d'Italia*. Milano, 1811, in 8vo, fig.

5. *Della Torba e della lignite nel Regno d'Italia*. Milano, in 8vo, fig.

6. *Domande relative all' Agricoltura*. Mil. in 4to.

1785. *Barbaro, Marco*.

Esperimenti sopra il grano fermentato, ed altre agrarie scoperte. Milano, in 8vo.

1790. *Rocca, Abbé Della*, vicar general of Scyros.

Traité complet sur les Abeilles, &c. i. e. A Complete Treatise on the Management of Bees, as practised at Scyros, together with an account of that Island. Paris. 8vo.

1791. *Caronelli, Pietro*.

1. *Apotegmi Agrarii, o sia istruzioni per via di massime tratte dalle opere de' due insigni agronomi Catone e Varrone*. Venezia, in 8vo.

2. *L'Agricoltura Italiana ridotta in proverbi, ovvero istruzioni per via di massime tratte dalle opere de' due insigni agronomi Catone e Varrone*. Venezia, 1807, in 8vo.

1793. *Lastri, Proposto*.

Calendarj dodici, o sia Corso completo d'Agricoltura pratica. Venezia, vol. iv., in 8vo.

1798. *Comparetti*.

Saggio sulla coltura e governo dei Boschi. Padova, in 8vo.

1798. *Doria, Luigi*.

Istituzioni georgiche per la Coltivazione de' grani ad uso delle campagne Romane. Roma, in 8vo, fig.

1800. *Livy, Cav.*

Three Memoirs on Agriculture; 1. On the Use of the A'iga marina in Agriculture and in the Arts; 2. On the Treatment of Vines; 3. On the Economy of the Flour which flies away in the Mill, and during the separation of the Bran. Palermo.

1801. *Simonde de Sismondi*, a distinguished literary character, who formerly managed an estate in the Vale of the Arno.

Tableau de l'Agriculture Toscane. Genève.

1802. *Fabbroni, Adamo*.

Dissertazione sopra il quesito: indicare le vere Teorie, con le quali devono eseguirsi le stime dei terreni, ec. Firenze, in 8vo.

2. *Della economia agraria dei Chinesi*. Memoria. Venezia, 1802, in 8vo.

1802. *Targioni, Luigi*.

1. *Lezioni di Agricoltura specialmente Toscana*. Firenze, vol. vi., in 8vo.

2. *Memorie su l'Agricoltura, la Pastorizia, e l'Applicazione dei Naturali prodotti agli usi degli abitanti dell' Italia, ed alla loro industria*. Napoli, 1814, vol. ix., in 8vo, fig.

1803. *Carradori, Gioachino*.

Della fertilita della terra. Pisa, in 8vo.

1803. *Vallée, Alexandre*.

Instructions élémentaires d'Agriculture, ou Guide Nécessaire au Cultivateur traduit de l'Italien de Fabbroni.

1804. *Ronconi, Ignazio*.

Dizionario d'Agricoltura, o sia la Coltivazione Italiana, in cui si contiene la coltura e conservazione dei diversi prodotti riguardanti le terre seminatve, i prati, i boschi, le vigne, ed i giardini, ec. Venezia, vol. v., in 8vo.

1805. *Piacenza, Giovanni*.

Nuovo metodo di fare le misure dei fieni, a che si aggiunge qual sia la migliore Agricoltura de' prati. Milano, in 8vo.

1807. *Barelle, Giuseppe*.

1. *Della Malattia della Golpe del grano turco*. Milano, in 8vo, fig.

2. *Saggio intorno la Fabbricazione del Cacio detto Parmigiano*. Milano, 1808, in 8vo.

3. *Monografia Agronomica dei Cereali del Frumento, trattato diviso in tre parti*. Milano, 1809, in 8vo, con rami e tavole.

1807. *Biroli, Giovanni*.

1. *Del riso, trattato economico rustico*. Milano, 8vo.

2. *Trattato di Agricoltura*. Novara, 1812, vol. iv. in 8vo, con tavole.

1807. *Galcotte, Francesco*.

Metodo per migliorare ed accrescere l'Agricoltura nello stato di Parma. Parma, in 8vo.

1807. *Gautieri, Giuseppe*, inspector of woods and forests to the Viceroy of Lombardy, author of a tract on forests. (See *Encyc. of Gard.* p. 1128.)

1. *Della ruggine del Frumento*. Milano, in 8vo, fig.

2. *Dei vantaggi e dei danni derivanti delle capre in confronto delle pecore*. Mil. 1816, in 8vo.

1808. *Abbate, Antonio*.

Coltivazione dei Bigatti o sia Metodo pratico per farli nascere, coltivarli nei varii periodi della loro vita, e fabbricarne la semente. Milano, 8vo.

1808. *Re, Filippo*, librarian to the Patriotic Society at Milan, afterwards in the employ of Government, at Turin, where he died in 1820 or 1821. He wrote a great number of works on rural and economical subjects.

1. *Elementi di economia campestre, ad uso de' Licei*. Milano, in 8vo, carta fina.

2. *Annali dell' Agricoltura del regno d'Italia cominciati in Gennaio 1809, e terminati in Giugno, 1814, fascicoli 66, for manti 22 vol. in 8vo, con circa 50 rami e tavole*.

3. *Del Cotone, e delle avvertenze per ben coltivarlo*. Milano, 1811, in 8vo.

4. *Nuovi Elementi di Agricoltura, volumi 4 in 8. Dedicati a S. A. R. Francesco IV. d'Este, Duca di Modena, ec. ec.*

5. *Dei Letami e delle altre sostanze adoperate in Italia, per migliorare i terreni e del come profittarne; Saggio*. Milano, 1815, in 8vo.

6. *Saggio sopra la Storia e il Coltivamento dell' Erba Medica*. Milano, 1817, in 8vo.

7. Saggio storico sullo stato e sulle vicende dell' Agricoltura Antica dei paesi posti fra l'Adriatico, l'Alpe, e l'Appennino, sino al Frontone. Mil. 1817, 8vo.

1807. *Tupputi, D.*

Réflexions sur l'Etat de l'Agriculture, et de quelques autres parties de l'Administration dans le Royaume de Naples, sous Ferdinand IV.; précédées d'une Introduction ou Coup-d'œil sur l'ancien Etat de ce Pays, et suivies d'un Mémoire, intitulé Recherches sur la Plante vulgairement nommée Storta dans le Royaume de Naples. 8vo.

1809. *Arduinio, Luigi.*

1. Memoria intorno la coltura ed usi economici del Cinosuro Corakan. Mil. 8vo, fig.

2. Nuovo metodo per estrarre lo zucchero dalle canne dell'Olio di Cafreia. Padova, 1811, 8vo, fig.

1809. *Tozzetti, Oct. Targ., M. D.*, professor of agriculture at Florence, and director of different national establishments there.

1. Dizionario dei Nomi di Botanica e di Agricoltura, Latino-Italiano e Italiano-Latino. Firenze, 2 vols. 8vo.

2. Lezioni d'Agricoltura. Firenze, 6 vols. 8vo.

1810. *Benetti, Santo.*

L'accorto Fattor di Villa, o sia Osservazioni utili ad un fattore per il governo della Campagna e per la soprintendenza ai Coloni. Venezia. 8vo.

1810. *Spadoni, Paolo.*

1. Modo di coltivare il Napo Silvestre detto volgarmente Ravizzone, e del metodo di cavarne l'olio alla maniera dei Bolognesi. Venezia. 8vo.

2. Dello stabilimento, piantagione e conservazione delle siepi, con il disegno per ben formarle. Venezia, 1810. 8vo.

1811. *Albertazzi, Jacopo Antonio.*

Il Padre di famiglia in casa ed in campagna. Milano, vol. vi. 12mo.

1811. *Giacinto, P. Carlo*, professor of botany in Malta.

Agricultural Essays, adapted to the Island of Malta. Messina.

1811. *Lampadius, Augusto Guglielmo.*

Esperimenti sopra lo zucchero di Barbabietole. Novara. 8vo.

1811. *Losana, Matteo.*

Delle Malattie del Grano in erba non curate o ben conosciute. Carmagnoli. 8vo.

1811. *Bassi, Agostino.*

1. Il Pastore bene instruito. Milano. 8vo.

2. Dell'utilità ed uso del Pomo di Terra, e dei metodi migliore di coltivarlo. Lodi, 1817. 8vo.

1812. *Dandolo, Vincenzo.*

1. Nuovi cenni sulla coltivazione de' Pomi di Terra, e vantaggi della medesima, rapporto al ben essere dell'uomo e dello stato, Lettera al Cav. Filippo Re. Como. 8vo.

2. Enologia, ovvero l'Arte di fare, conservare, e far viaggiare i vini del Regno d'Italia. Milano, 1812, vol. ii. 8vo, fig.

Gagliardo, G. B.

Catechismo agrario per uso dei curati di campagne, e de' fattori delle ville. Napoli, terza edizione, con aggiunte. 8vo.

1815. *Galliziotti, Filippo.*

Sulla dimora alla campagna dei ricchi possidenti e dell'

utilità dell'istruzione degli ecclesiastici nell'agricoltura. Firenze. 8vo.

1815. *Malenotti, Ignazio.*

Il padrone contadino, osservazioni agrario-critiche. Colle. 8vo, fig.

1816. *Finorchi, Anton. Maria.*

Regole teoriche-pratiche e rustico-legali per fare le stime dei predj rustici. Firenze. 8vo.

1816. *Ricci, Jacopo.*

1. Catechismo Agrario. Firenze. 8vo.

2. Del vino, delle sue malattie, e dei suoi rimedi, e dei mezzi per iscoprirne le falsificazioni; dei vini artificiali, e della fabbricazione dell'aceto. 8vo.

1816. *Onorati, Niccola Columella.*

1. Delle patate, loro coltura, uso economico, e maniera di farne il pane. Milano. 18mo.

2. Saggi di economia campestre e domestica pei dodici mesi dell'anno, ad uso degli agricoltori, dei pastori, e di altra gente industriosa. 18mo.

3. De' Vinaccioli e del modo di estrarne l'olio, e di altri vantaggi che si possono ottenere da' medesimi. Napoli, 1818. 8vo.

1817. *Landeschi, ———*, parish priest of Saint Miniato.

Saggio di Agricoltura, con note di Antonio Becchi. Firenze. 8vo, fig.

1818. *Ferrario, G. A.*

L'Agente in Campagna o sia regola sperimentata per migliorare i prodotti d'ogni genere d'Agricoltura secondo le terre del regno d'Italia; opera accomodata all'intelligenza de contadini per loro maggior profitto. Milano. 8vo.

1818. *Gialdi, Giuseppe.*

Lezione proemiale d'Agricoltura practica ragionata. Parma. 8vo.

1818. *Redolft, Cosimo.*

Memoria sopra un nuovo metodo per ottenere la farina di patate; sull'orzo, sull'acido muriatico, sulle zuppe economiche, e sulla ruggine del grano. Firen. 8vo.

1825. *Giacinto, Carlo.*

Mezzo stabile di prosperità per le Isole di Malta e Gozo. Malta. 8vo.

1825. *Anon.*

Atti del real istituto d'incoraggiamento, &c. Di Napoli. tom. i.

1826. *Le Prévôt de Rivolta.*

Nuovo metodo di Agricoltura. Lodi. 16mo.

1826. *Anon.*

Il fattore di campagna. A monthly agricultural journal. Milano. 8vo.

1826. *Moretti, Dr. G.*, editor, professor of rural economy in the university of Pavia.

Biblioteca agraria. Milan. 16mo, vol. i.

1826. *Sartorelli, G. B.*

Osservazioni sopra i mezzi di conservare i Boschi mediante.

1827. *Bonafous, M. Mathieu*, Director of the Experimental Garden of the Royal Central Agricultural Society of Turin.

Osservazioni ed Esperienze agrarie. Turin. 8vo.

SUBJECT. 4. Bibliography of the Agriculture of the other Countries of Europe.

7903. *Germany and Britain* are the only countries in Europe in which it answers to print agricultural books for the sake of the indigenous readers. In Britain, education is so general among the middling and lower orders, that reading among them is a necessary convenience of life; in Germany, education and reading are equally general and essential: and consequently, in either of these two countries a book will pay by its sale within the country. But this is not the case in any other European country. In France the mass of the people do not read, but books printed there pay, because they are in a language more universal than any other, and perfectly understood by all men of education in Europe. Italian books pay, because they are enquired for by the agriculturists of the south of France, all Spain, and in part of Spanish America.

7904. *Spanish and Portuguese books on agriculture* are in much too limited a demand for production. The earliest Spanish author is Herrera, in 1596; and there are scarcely half a dozen since. After the most particular researches of a book agent at Madrid, he was only able to send a list of translations, and the transactions of the Economical Society of Madrid; who have also published Herrera's work with notes within the present century. In 1815, a professor at Madrid published *Lecciones de Agricultura explicadas en el Jardin Botanico*, 2 tomes 4to. An anonymous author, *Disertaciones sobre varios Piantos Agronomicos*, 1 tom. 4to. Of Portuguese books we could hear of none.

7905. *Of Flemish and Dutch books on agriculture* there are scarcely any. These languages are very limited, and every reader in Holland or Flanders understands French or German. Many works have been published in the Low Countries in Latin and French, but these cannot be considered indigenous. The few Dutch works on culture belong almost all to gardening (*Encyc. of Gar.* 7695.). The result of our correspondence with Amsterdam is a *Nieuwe Naamlijst van Boeken, &c.*, from which we see little worth taking. There are several translations from British works on culture, and French veterinary books, and the following seem the latest on husbandry.

Magazijn van Vaderlandschen Landbouw, door J. Kops, Commissaris tot den Landbouw. 6 deelen compleet met register.

Aanwijzing ter verbetering van de Akkerbouw en Landhuishoukunde, in de Nederlanden, door Professor A. Bruchausen. 2 deelen.

De Boeren Goudmijn, of kunst, om van verschillende soorten van Landerijen, het meeste nut te trekken, meer Vee te kunnen houden, en andere Wetenswaardigheden tot den Landbouw, door J. F. Serurier en J. Kops, met platen.

Lichtervelde, J. F. de, Member of the Royal Society of Agriculture and Botany of the city of Ghent: La Bêche, ou la Mine d'Or de la Flandre Orientale. Brussels. 8vo.

Cale's, M. V. M., M.D. at Liege: Instructions sur le Parcage des Moutons; ou, Moyen d'engraisser les Campagnes en faisant coucher les Moutons dans les Champs. Liège. Pamph. 8vo.

7906. *Of Swedish and Danish books on agriculture*, there are necessarily very few; these languages being of very limited use, and the mass of the people too poor to be able to afford to read about ordinary matters, or what they consider as already well known to them. The time such a people give to reading will be devoted to religious subjects, heroic and romantic poetry, or history. The universities of Stockholm and Upsal, every one knows, have produced some useful naturalists: some of these have

written tracts on agricultural improvements, especially on planting fruit-trees (*Frukt-Träd.*) and cultivating eulinary vegetables (*Köchs-och Krydd.*). A few of such works we have enumerated in our Bibliography of Gardening (7696.), but we can scarcely find any fit to be inserted here as agricultural. *The Natural and Chemical Elements of Agriculture*, by Count Gustavus Adolphus Gyllenborg, a learned Swedish statesman, were translated by John Mills in 1770, and may be considered as the prototype of *Davy's Agricultural Chemistry*. There are several treatises on the culture of the potatoe in the *Swedish Transactions*; also on tobacco, on the management of sandy soils, on the cultivation of the Cerealia; and on the hop and plants for fodder.

1825. *Anon.*: Kongl. Svenska Landtbruks Academiens Annala. Year 9. Part I. 8vo.

1826. *Winstrup, M.*, machinist to the king at Fredericksberg, near Copenhagen: Afbildwinger af de bedste og nyeste Agerdyrkningsredskaber, &c. Copenhagen. 4to.

7907. *Of Polish and Russian books on agriculture*, it may be easily conceived, there are very few. Some translations from French works were made into the Polish language under Fred. Augustus II.; but few or none since that time, the German or French being universally understood by the reading class. Books of agriculture in the Russian language could be of little use. The only things printed in that way there are in the transactions of the Economical Society of St. Petersburg, by foreigners resident there, and in Latin or German. The best informed Russian nobles read French or German like the Poles. There is an agricultural society at Warsaw, which occasionally prints its transactions; and another has lately been established at Moseow, which publishes an agricultural newspaper. (*See Gard. Mag.* vols. i. and ii.)

1825. *Partof, M.*: Zmliédeltcheskaia Chimia. Moseow. 8vo.

1825. *Apraxin, M.*, a nobleman possessing one of the largest houses in Moseow: Zemliédeltchesky Journal, &c. Moscow. 8vo.

1825. *Anon.*: Avantages résultant de l'Introduction de la Culture variée des Terres. Warsaw. 8vo.

SUBJECT. 5. *Agricultural Bibliography of North America.*

7908. *There are a few American books of agriculture*, and republications there of most of our best works on the subject. Dean's *New England Farmer's Dictionary* and Dwight's *Travels* may be considered as giving an idea of the husbandry of that part of the country, and Roughley's *Jamaica Planter* of the agriculture of the West India Islands. A number of interesting papers on the subject will be found in the transactions of the American, New York, Philadelphia, and other societies.

1744. *Bartram, John, M.D.*, Philadelphia.

On the Salt Marsh Musell: On Oyster Banks and the Fresh Water Musell of Pennsylvania. (*Phil. Trans. Abr.* ix. p. 70.)

1754. *Fleming, or Fleming, Malcolm, M.D.*, of Brigg.

A Proposal in order to demonstrate the Progress of the Distemper among Horned Cattle: supported by Facts. York. 8vo.

1755. *Belgrove, William.*

A Treatise upon Husbandry and Planting. Boston, New England. 4to.

1764. *Elliot.*

Essays upon the Husbandry in New England. Lond. 4to.

1779. *Carver, Jonathan, Esq.*, born in America in 1732; died at London, 1780, in great poverty.

A Treatise on the Culture of the Tobacco Plant, with the Manner in which it is usually cured, adapted to Northern Climates, and designed for the Use of Landholders of Great Britain, with two Plates of the Plant and its Flowers. Lond. 8vo.

1785—1826. *Anon.*

Memoirs of the Philadelphia Society for promoting Agriculture; containing Communications on various Subjects in Husbandry and Rural Affairs. Philadelphia. 8vo.

1789. *Antill, Hon. Edward, Esq.*, of New Jersey.

1. An Essay on the Cultivation of the Vine, and the making and preserving of Wine, suited to the different Climates of North America. (*Americ. Trans.* i. 181.)

2. The Method of curing Figs; and Observations on the raising and dressing of Hemp. (*Ib.* i. 266.)

1789. *Bartram, Moses.*

Observations on the Native Silk Worms of North America. (*Americ. Trans.* i. 294.)

1789. *Carter, Landon*, of Sabine Hall, Virginia.

Observations concerning the Fly-weevil that destroys the Wheat; with some useful Discoveries and Conclusions. (*Trans. Americ. Soc.* i. 274.)

1790. *Dean, Dr.*

New England Farmer's Dictionary.

1796. *Higgins, Jesse*, of Delaware.

A Method of draining Ponds in Level Grounds. (*Trans. Amer. Soc.* vol. iii. p. 325.)

179 . *Greenway, Dr. James*, of Dinwiddie county, in Virginia.

Of the Beneficial Effects of the Cassia Chamæcrista in recruiting worn-out Lands, and enriching such as are naturally Poor. (*Trans. Amer. Soc.* iii. p. 226.)

1800. *Destère.*

La Science du Cultivateur American: Ouvrage destiné aux Colons et aux Commerçans. 8vo.

1801. *Bordley, J. B.*

Essays and Notes on Husbandry and Rural Affairs. Philadelphia. 8vo.

1812. *Barton, Benjamin Smith, M.D.*, professor of natural history and botany in the university of Philadelphia.

On the Native Country of the Solanum tuberosum, or Potato. (*Nic. Jour.* xxxi. 290.)

1821—1826. *Anon.*

Memoirs of the Board of Agriculture of the State of New York. Albany. 8vo. 5 vols. to 1826.

1822. *Fessenden, Thomas G.*

The New England Farmer; containing Essays, original and selected, relating to Agriculture and Domestic Economy, with Engravings and the Prices of Country Produces. Boston. 5 vols. 4to to 1827.

1823. *Roughley, Thomas*, nearly twenty years a sugar planter in Jamaica.

The Jamaica Planter's Guide; or, a System for planting and managing a Sugar Estate or other Plantations in that Island, and throughout the British West Indies in general. Illustrated with interesting Anecdotes. 8vo.

1825. *Anon.*

The Ploughboy. Vol. ii. 4to.

1825. *Anon.*

Massachusetts Agricultural Repository and Journal. 7 vols. 4to.

1828. *Anon.*

New York Farmer and Horticultural Repository. New York. 4to.

1829. *Lathrop, E. L., Esq.*

The Farmer's Library; a Series of Essays and Papers for the Promotion of the Study of Agriculture. (Windsor, U. S. 12mo.)

CHAP. V.

Professional Police and Public Laws relative to Agriculturists and Agriculture.

7909. *By professional police* we mean those associations which agriculturists have formed, at different times and in different manners, for mutual benefit or instruction; and also those institutions for the same purpose established by the legislature, or of such a nature as to be considered public or national. By laws we allude to those special legislative enactments which affect more particularly agriculture. These are so numerous that we must refer the reader to his lawyer or law dictionary.

7910. *There are few or no agricultural lodges* of the nature of those of masonry or gardening. In Scotland it would appear something of this kind had existed among ploughmen at one time, as the passwords and initiatory ceremonies are talked of in some of the counties by old men. In Forfar, Kincardine, Banff,

&c. it is not uncommon for ploughmen, as well as various descriptions of operatives, to belong to gardeners' lodges. In the southern districts where sheep farming is followed there are some shepherds' societies, for mutual interchange of experience, and aid in case of losses of such sheep as are the shepherd's perquisite. There are some ploughmen's clubs in different places, and various associations among them of the nature of benefit societies; but these do not come under the description of professional.

7911. *Agricultural societies* for interchange of knowledge are of modern date, but they have increased rapidly since 1794: the number at present or lately existing in the British isles is at least equal to the number of the counties. Societies of this description are either general, as the Board of Agriculture and Society of Arts; national, as the Highland Society and Dublin Institution; particular, as the Bath and West of England Society; provincial, as county societies; or parochial, as being limited to a few individuals within one parish. Of this kind are farmers' clubs, ploughing societies, &c. In regard to the end in view, these societies either embrace the arts in general; the rural arts in general; some branch of the rural art, as agriculture; or some department in that branch, as live stock, sheep, wool, &c.

7912. *All these societies hold meetings* at stated periods. Most of them offer premiums for particular objects, — specimens of vegetable or animal culture or produce, agricultural operations, moral and professional merits as servants, &c.; some of them form a library and museum of models or full-sized implements; a few publish transactions; and one or two, as the Dublin Society, send out itinerant ploughmen and agricultural mechanics to instruct practical farmers. These societies are almost wholly supported, and the funds for premiums raised, by the subscriptions of members, and by voluntary donations, legacies, &c.; but some, as the Board of Agriculture and the Dublin Society, have received assistance from government.

7913. *Of English agricultural societies* the oldest is the Society of Arts, founded in 1754 by Lord Folkestone, Lord Romney, Dr. Hales, and Shepley. They have published many volumes of transactions, awarded immense sums in premiums, and on the whole done much good. (See *Rees's Cyc.* art. *Society*.)

7914. *The Bath and West of England Society* was founded in 1777, for purposes similar to those of the London Society of Arts. They have published some valuable volumes of transactions, and distributed various rewards, &c. (*Rees's Cyc.* &c.)

7915. *The Board of Agriculture* was founded, under the authority of government, in 1793. Much was expected from this Board; but, except the publication of the county reports, and the general attention which it called to agriculture, it may well be asked what advantages arose from it. Their *Communications*, in several quarto volumes, contain fewer valuable papers, in proportion to their total number, than the publications of either the London Society of Arts or the Bath Society. In short it has been ably shown, in *The Farmer's Magazine* and

the article *Agriculture* in the supplement to the *Encyc. Brit.*, that the Board never directed its efforts in a manner suitable to its powers and consequence; and that, instead of discussing modes of culture, its attention ought to have been directed to the removal of the political obstacles to agriculture, and to the eliciting of agricultural talent by honorary rewards, &c. No idea is more erroneous than that of such a Board, or any other, doing much good by a national "experimental farm." The government withdrew its support from this Board about 1816; and there being no longer funds for a handsome salary for a secretary, it soon after fell to pieces, and is now only remembered, at least by us, for its lofty pretensions and its worse than inutility.

7916. *Of Welsh societies* there are only two or three, of inferior note, which have been already noticed in the topography of the country.

7917. *Of Scotch societies* the principal now existing are the Highland Society and the Dalkeith Farming Society.

7918. *The Highland Society* of Scotland was established in 1715, to enquire into the state of the highlands, to consider the means of their improvement and the preservation of their language; it is chiefly supported by the subscriptions of its mem-

bers, at a guinea each a year, and soon after its establishment it had a grant of 3000*l.* from government. It has published 7 vols. of prize essays and papers, and now extends its prizes to all the low counties of Scotland. (*Farm. Mag.* vol. 16. p. 316.)

7919. *Of Irish societies* the principal are the Dublin Society and the Cork Institution.

7920. *The Dublin Society* was established in 1731, and incorporated in 1749. Arthur Young observes, that it was the parent of all the similar societies now existing in Europe; but the Edinburgh Agricultural Society, as we have seen (775. and 801.), was established nearly ten years before. The Dublin Society, in its present advanced state, is one of the most complete establishments of the kind. (*Rees's Cyc.* art. *Dublin*.)

7921. *The Farming Society of Ireland* was established under the patronage of the Dublin Society, in 1800. The object is to improve the agriculture and live stock of the kingdom. (*Archer's Dublin*, 160.)

7922. *The Cork Institution*, for applying science to the com-

mon purposes of life, originated in private subscriptions, about the beginning of the present century. It has since been incorporated, and has received the assistance of government. It possesses a house and a large botanic garden, and under its auspices are delivered lectures on chemistry, botany, agriculture, &c.; it is not, however, in a flourishing state, and has never been of much use.

7923. *The principal county societies* in the three kingdoms have been noticed in the topography of agriculture: many of them were established several years before the Board of Agriculture.

7924. *The only other institutions for the improvement of agriculturists and agriculture* are public professorships. Of these there is one in the university of Edinburgh, established in 1795; one in Dublin, supported by the Dublin Society; one in Cork; and one is destined to be established at some future period in Oxford, agreeably to the will and donation of Dr. Sibthorpe (806. and 7789.), professor of botany there.

BOOK II.

THE FUTURE PROGRESS OF AGRICULTURE IN BRITAIN.

7925. *THE improvement of agriculture*, like that of every art, manufacture, or commodity, necessarily depends on demand and production: a powerful or effectual demand will ensure produce, and excellent produce will, to a certain extent, create demand. A general nicety of taste in coach or saddle horses will call forth a superior description of these animals, and superior animals will tempt purchasers; if the inhabitants of any district who live chiefly on barley or oats indicate a preference for wheat, and a willingness to pay for that grain, wheat will be produced, and so on. Again, as the object of every individual who engages in art or trade is to acquire gain, the advancement of an art will depend mainly on the profits it affords; an art or occupation which affords less than the average profits on capital will only be followed by such as, from habit or other reasons, cannot apply themselves to any thing better, but extra-profits

will command both capital and skill. From these considerations it is obvious, that the improvement of agriculture depends on the profits on capital employed in it, on the taste of those who purchase its products, and on the knowledge of those who are engaged in agriculture as a profession. The first subject would lead us further into political economy than would be of much use in a work of this kind, and therefore we shall limit ourselves to a few remarks on the other topics.

CHAP. I.

Improvement of Agriculture, by refining the Taste of the Purchasers of its Products, and increasing the Knowledge of Agricultural Patrons.

7926. *The desire of being comfortable* is the first step towards improvement ; but before any thing can be desired, we must know what it is. Men, when they know of nothing better, rest satisfied with what they have ; and therefore one of the main sources of improving the taste both of those who purchase agricultural produce from necessity, and of those patrons of agriculture who purchase from the conjoined impulses of necessity and choice, is the increase of knowledge. However paradoxical it may seem, discontent is the parent of all improvement, as certainly as the acorn is the germ of the future oak, or the time present that of all future times. The grand achievement of the present age, an eminent writer observes (*Examiner*, Jan. 9. 1831.), “ is the diffusion of superficial knowledge ;” and on this diffusion, superficial though it may be, the progress of agriculture and of every other art depends far more than on any thing else.

7927. *In Scotland and Ireland* could a taste for wheaten bread and butcher’s meat be introduced generally among the operative classes, the advantages to agriculture would be immense. Could the same persons be taught to desire a greater degree of cleanliness, light, and warmth in their cottages ; a greater variety of potherbs, salads, fruits, and flowers in their gardens ; and handsome dresses for their wives and daughters, how great the general benefit ! Much may be done to bring about this change, by the opulent who are willing to reside on their estates and to take a little trouble. Building good and comfortable cottages ; attaching proper gardens stocked with trees and plants from the demesne garden ; and offering little premiums, or marks of distinction for keeping them in the nicest order, and for decently clothed well-bred children, would soon have a sensible effect. Attending to that kind of education which consists in teaching infants civility and politeness, with mutual respect and restraint as occasion requires ; and instructing grown children how to work at almost every thing likely to come in their way, as done in the improved German and Swiss schools, would, independently of reading and writing, do a great deal to soften and humanise the peasant mind. Encouragement should be given to save money for unforeseen wants, or against old age ; and the certain effects pointed out of early marriages, followed by a numerous offspring. These and a variety of similar means would be productive of some change of taste in the operative part of rural society.

7928. *The introduction of manufacturing establishments*, wherever it could be properly done, would contribute to the same effect : those who work at manufactures, and even common mechanics, generally live better, and are better clothed and lodged, than the common country labourer ; therefore their example would be of use in introducing a salutary degree of luxury. “ The endeavouring to impress on the minds of the lower classes the propriety of being contented with the simplest and cheapest fare, is extremely pernicious to the best interests of mankind. Encomiums ought not to be bestowed on those who are contented with mere necessaries : on the contrary, such indifference ought to be held disgraceful. A taste for the comforts, the enjoyments, and even the luxuries of life, should be as widely diffused as possible, and, if practicable, interwoven with the national character and prejudices. This, as it appears to us, is the best mode of attempting the amelioration of the condition of the lower classes. Luxuries, and if you will have it so, even wasteful habits, are incomparably better than that cold, sluggish apathy, which would content itself with what can barely continue mere animal existence.” Mr. Peel observed in the House of Commons that “ he thought it one of the first duties of the legislature, to do all in its power to excite a taste in the humbler classes of society for those comforts and those enjoyments — those luxuries, he might add — of civilised society, the desire for which, and the habitual possession of which, would form the best guarantee for their good conduct, and the best guarantee that the higher classes could have for the possession of their property and their power, as at present enjoyed.” (*Manual of Cottage Gardening, Husbandry, and Architecture, &c.*) “ In those countries,” Ricardo judiciously observes, “ where the labouring classes have the fewest wants, and are contented with the cheapest food, the people are exposed to the greatest vicissitudes and miseries : they have no place of refuge from calamity ; they cannot seek safety in a lower station ; they are already so low that they can fall no lower. On any deficiency of the chief article of their subsistence, there are few substitutes of which they can avail themselves, and dearth to them is attended with almost all the evils of famine.” (*Sup. Encyc. Brit. art. Corn Laws.*) Such is the case in Ireland, where, amidst the germs of the greatest riches and luxury, the inhabitants are contented to live on less than any other people in the world.

7929. *The taste of the superior patrons* of agriculture is to be improved by visiting the best cultivated districts, reading agricultural works, attending agricultural societies, and, above all, by cultivating a farm, and establishing on it a systematic order and regularity in every detail. Let such observe the hedges, gates, verges of fields, and the beautiful rows of turnips, of Berwickshire or Northumberland ; the correctly drilled beans of East Lothian ; and the live stock of Leicestershire. But few are the proprietors of lands who either employ a proper bailiff or demesne steward ; and of those who do, how few who do not limit and fetter them in their operations, or else neglect them and leave them to sink into that supine state in which the uppermost wish is to enjoy the comforts of the situation with the least possible degree of exertion ! Some proprietors desire to have their home farm managed with a view to profit, as the cheapest way of getting hay, straw, mutton, &c. ; these are sordid patrons. A home farm ought to combine an elegant orderly style of management, high-kept horses, harness, implements, &c., well clothed servants, and every thing in a superior style to what is seen on common farms. Particular attention ought to be paid to the buildings, which should combine architectural design, fitness, strength, and elegance ; the roads ought to be like approaches to a mansion ; the hedges like those of gardens ; the green verges round the fields kept mown like lawns or grass walks, and the ditches, bridges, and gates in corresponding neatness ; the finest trees ought to be encouraged in proper situations, and correctly pruned ; substantial watering places formed and kept supplied ; every operation on plants, or the ground, performed in a garden-like manner ; and no individual of any species of stock kept, of which a drawing might not be taken and preserved as a beauty. Even the dress and deportment of the servants on such a farm ought to harmonise with the rich culture, orderly display, and high keeping of the whole.

CHAP. II.

Improvement of Agriculture, by the better Education of those who are engaged in it as a Profession.

7930. *By education* is generally understood that portion of knowledge which is obtained at schools; but in a more extended sense (as Mills observes), it may be defined the means which are employed to render man competent for pursuing the part which he undertakes to perform in life, with increased satisfaction to himself and others. Education may thus be considered as extending to every thing which operates on the body or mind, from the earliest periods of our existence to the final extinction of life. It is unnecessary here to embrace the subject in its full extent; but we shall offer some remarks on the education of practical men in general, on the professional education of an agriculturist, and on the general conduct and economy of his life.

SECT. I. *Degree of Knowledge which may be attained by Practical Men, and general Powers of the human Mind as to Attainments.*

7931. *The kind and degree of education* that we think ought to be given to every human being in this and in every country, and in every state of civilisation, may be thus defined: — All the knowledge and accomplishments that a child's body or mind, and the state of knowledge and the art of teaching at the time, will admit, previously to the age of puberty; giving preference to those branches of knowledge considered the most useful, and those accomplishments and manners considered the most humanising, by the wise and good of the age. It seems unreasonable to employ any child in aiding to procure the means of its subsistence, or that of its parents, before the age of puberty. Previously to that age, by means of infant schools, and of the adoption of the various improvements that have been recently made in modes of teaching, all that is worth knowing may be taught more effectually than common reading, writing, and arithmetic are, during the same time, by the common methods. Man, so trained and instructed, and living under an enlightened government, will become as different an animal from what he is at present, even in Britain, as the most enlightened modern moralist and philosopher of Europe is from an African savage. "It is not necessary," says Lequinio, writing in 1792, "to render an agricultural labourer a learned man;" but I am well assured, from my own experience, that the knowledge of every thing useful, and of much that is agreeable, both in knowledge and manners, is perfectly consistent with a life of labour in the fields. But hitherto the education of the labouring classes in the country has proved rather an obstacle to the development of reason than otherwise. Eight or ten years are employed in filling the head of a child with chimeras and prejudices, which twenty years of study will scarcely succeed in entirely rooting out. It remains for national philosophical institutions to destroy this national evil; and we shall one day have under the thatched cottage of the country hamlet thinking men endowed with reason, and capable at once of taking a part in the political and moral affairs of their country, and holding the plough or guiding the cart on their own farm. "Il faut," says this admirable writer, "que les premières leçons soient l'apprentissage des droits de l'homme, et qu'ils soient enseignés sans aucun mélange des perfides principes du fanatisme et des fruits barbares des gothiques préjugés, de quelqu'espèce que ce puisse être. Les notions de la raison et du bon sens tombent sous tous les intellects. Les droits de l'homme intéressent tous les individus, et l'esprit et le cœur seront bientôt d'accord pour s'en faire une science impérissable; gravés une fois, je le répète, ils ne s'effaceront jamais; ils se conçoivent avec aisance, et ils se fixeront bien plus solidement que ces antiques assertions données sur la foi d'autrui, et transmises à travers les ténèbres des siècles les plus obscurs; assertions ridicules, et qui, pour la plupart, n'ont seulement pas en leur la simple vraisemblance; ils se fixeront, sur-tout, parcequ'ils seront aisément et avantageusement comparés à toutes ces faussetés miraculeuses et folles dont le néant alors éclatera pour tous, et parcequ'ils seront encore plus avantageusement mis en parallèle avec ces mystères absurdes que l'homme ne pouvait admettre qu'en rejetant l'évidence, et en se dépouillant totalement de son intelligence et de sa raison. C'est par ce simple enseignement que s'élèvera tout d'un coup dans nos campagnes une espèce raisonnante et libre. Sortie, par cette création morale, du cahos ténébreux, et de l'existence léthargique où, depuis le commencement des siècles, elle croupissait sous le joug de tous les impudens habiles qui se permettaient de la dominer, nous la verrons une race nouvelle, intelligente et hardie, laisser un espace incommensurable entr'elle et les générations qui l'ont précédée." (*Les Préjugés détruits, par J. M. Lequinio. Paris, 1792. Parochial Institutions; or, an Outline of a Plan for a National Education Establishment, &c.: and Des Etablissemens pour l'Education Publique en Bavière, dans le Wurtemberg, et dans le Pays de Bade.*)

7932. *A high and equal degree of education* has some powerful advocates in North America, and, it is thought by many, will, at no distant period, be adopted in several of the states. The *New York Daily Sentinel* and the *Working Man's Advocate* are two of several newspapers which support what are called "working men's measures." Among these the first and most important is a "republican education, free for all, equal for all, and at the expense of all; conducted under the guardianship of the state, at the expense of the state; embracing every branch of useful instruction, moral, intellectual, and operative, and extending to the entire protection, maintenance, and guidance of children and youth, male and female, without distinction of class, sect, or party, or reference to any of the arbitrary distinctions of the existing state of society." (*Six Essays on Public Education, New York, 1830; Cooper's Lectures on Political Economy, as quoted in the Spectator, Dec. 4. 1830: and Gard. Mag. vol. vii.*)

7933. *This high and equal degree of education* we consider to be as much the birthright of a child in a community where there is a high degree of civilisation, as food and clothes are its birthright in the rudest state of society; because, without it, a man or woman is ushered into society without a fair chance of being able to procure those means of subsistence and of happiness which belong to human nature under the given degree of civilisation; in short, without a fair chance of making the most of life. To introduce an ignorant youth into a highly civilised country, under the supposition that he could obtain the requisite degree of prosperity and happiness, would be more absurd than to turn an educated child into a country of savages. This is one view of the subject, and it is a view on which all who can afford the expense act with respect to their own children. If we regard the subject in the light of humanity, and the sympathy of one part of society with another, this principle will equally dictate the duty of bestowing, as far as practicable, that good on others which we feel to be a good in ourselves, and which we are convinced would add to the general happiness. Viewed as a matter of public policy, and considering that the grand object of every government ought to be, with reference to its subjects, their happiness and prosperity; and, with reference to other governments, its own stability; reason dictates the use of the most important means for gaining these ends; and that it would be prudent, no less than just, in government so to legislate, as that every individual subject should have the degree of education above defined. Let none,

therefore, exist in society who have not their minds matured by the care and culture of public teachers, as their bodies are by the nourishment and clothing of their parents. The religious and humane owe this to the poor as a part of human nature; the benevolent, as sympathising with the miseries they suffer; the enlightened, in order to raise them to their rank in the scale of creation; the rich, to give them a greater chance of possessing property, in order that they may respect the property of others; the prudent, that they also may become prudent; and government, that they may not be made the tools of faction, foreign or domestic. (*Parochial Institutions, &c.*)

7934. *Knowledge gives power*; and if one part of society has the degree of cultivation desired, and the other has it not, it is evident that there can be very little sympathy between them. The experience of ages shows the continual tendency of the powerful in wealth or in skill to oppress the weak; and the continual tendency of the weak to re-act by personal force, by cunning, or by numbers, on the strong. Materials so discordant can never form the basis of a sound, healthy, and permanent state of society: the poor and ignorant becoming, under such circumstances, little better than slaves to the rich and enlightened, regard them as their enemies, and often finding them to be such, must and will rebel; and the result is, sooner or later, a subversion of society. It would evidently contribute to the stability and harmony of society to moderate this action and re-action, by a more equal distribution of power; and, as knowledge gives power, the most obvious and effectual way of attaining the end proposed is, by diffusing such a high and equal degree of school education as we have defined. It must be evident, we think, that the state of society which this degree of education will sooner or later produce, will include in it every amelioration and happiness of which human nature, under any given circumstances, is susceptible. (*Ibid.*)

7935. *The knowledge of languages, history, geography, arts, sciences, and literature*, which an agriculturist, whether a ploughman, shepherd, bailiff, steward, or rent-paying farmer, daily occupied with his profession, may acquire by his own exertions, provided he begins at the earliest moment, say at fifteen years of age, and continues to employ his leisure hours in reading till he is twenty or twenty-five, is by no means inconsiderable; not that he can or need become learned; but, if desirous, he may become generally intelligent, render himself fit, as far as conversation is concerned, for good society, prove instructive and entertaining to others by his conversation, and provide a reserve fund of enjoyment, by laying up a store of ideas for reflection in misfortune, disease, or old age.

7936. *The utility of knowledge* to that part of mankind who are doomed to a life of mechanical labour, or rather who suffer themselves to be doomed to it, has been questioned; it is said to render them dissatisfied with their condition, to produce various other evils, and at all events in no way to add to their happiness or the good of society. To a man whose business in life is the mere mechanical performance of operations which any other animal might perform if furnished with hands, education is doubtless less necessary than to a man whose business is to direct the operations of others; but it does not follow, that though less necessary, it may not be highly useful: if, for example, it renders him dissatisfied with his condition, it will, at the same time, be more likely than any thing else to lead him to some proper mode of improving it; or if almost unimprovable, education certainly will be more likely than a state of ignorance to teach patience and submission, by enabling him to reflect on the folly of grieving at what is inevitable, and the consequences of committing what is unjust or criminal to relieve himself. "The low Irish," Marshal remarks, "are sufficiently dissatisfied with their condition; those who know how to alleviate it by emigration, go to Britain or America; those who know nothing, stay at home, commit acts of violence, and are hanged."

7937. *To decide as to the utility of knowledge to the operative parts of society* would perhaps require a previous decision of the question, "What constitutes happiness?" The general answer is, the exercise of all our faculties of body and mind: every one who has lived thirty or forty years in the world, knows that there is no such thing as absolute happiness: the Prince de Ligne, a man of great natural parts, with every advantage of person, birth, and wealth, and in favour at all the courts of Europe; fond alike of war, literature, gallantry, and agriculture, and who lived to be upwards of 90 years of age, has left on record that he was only perfectly happy two or three times in his life, and only for a few minutes each time. Forsyth (*Principles of Moral Science*, vol. i. chap. 1.) says perfect happiness is a thing not to be thought of; and that all that men and women can do in order to make the most of their existence, is to occupy themselves and make progress in whatever they engage in: progress in enjoyment, or approximation to happiness, is therefore the object to have in view.

7938. *The utility of knowledge to every human being* is consequently, in our opinion, unquestionable, on the mere principle of adding to enjoyment; nor do we believe that there is more danger from excess of knowledge in any particular class of society, high or low, than there is from excess in their eating or drinking. A number of men possessed of property or power by inheritance, favour, or chance, who are very conscious that they never could have acquired those advantages by the common competition of talent and industry, and who are in fact wrapt up in selfishness, are naturally jealous of the progress of knowledge; their secret maxim is to keep down the lower orders, and to impress on their minds only the duties of loyalty, religion, and, as Vancouver adds, hard work. This monopoly of power and knowledge, however, cannot be maintained for ever, and in every country it is found rapidly yielding to the general progress of society. It is only those who have to dread this progress that fear the diffusion of education and liberal principles.

7939. *Education in all countries*, in as far as it has been carried, has had the effect of rendering the poor content. Compare the poor of Sweden and Germany with those of England. The uneducated are prone to consider wealth and happiness as synonymous, a delusion which knowledge quickly dispels; philosophy teaches its fallacy, and history exemplifies it. For our own part, we can see nothing in education but increased security to the rich, and increased happiness to the poor. One of the great evils which at present afflict society in this country is over-production; not only of manufactured goods, but also of human beings. We are apt to believe that even this calamity might be remedied, if every labourer in the country considered a high and equal degree of education as a necessary of life, and no more to be dispensed with in a child than food or clothing; as in that case he would not think of marrying till he could bestow this degree of education on his children. If any labourer acted otherwise, he would bring himself into disgrace among his own class; he would suffer a loss of reputation for good sense and good taste; and his wife and himself would no longer be able to associate with their neighbours, either from the extraordinary exertions which they must make, in order to educate their children up to the general level, or in consequence of not being able to do so, and having it done for them by the parish as paupers. The dread of the reflections and neglect of the children when they arrived at maturity, and found that they were indebted to the parish more than to their parents for their education, and that they had, in fact, to pay the parish for this education themselves, would also act as a powerful inducement to prudential conduct. Besides, when parents themselves have once enjoyed the degree of education defined, they will consider it cruel and unjust not to bestow the same degree of education on their children. This is, in fact, the feeling of all educated parents; and one great object that we have in view is to communicate the same feeling to the very lowest member of society. We are justified in concluding that universal education would do so, by what actually takes place at present among the educated classes. (*Parochial Institutions, &c.*; and *The Objects to be obtained by Reform in Parliament, &c.*)

7940. *The terms knowledge and ignorance are entirely relative*: the knowledge of a modern chemist's porter would have subjected him to be hanged and burned in the days of the first popes; and any bricklayer's labourer of the present day, who reads the London newspapers, has more correct ideas of the principles of political economy than nine tenths of the nobility in Russia and Spain. It is impossible to set limits to the knowledge which may be obtained by those who are destined even to the most severe and constant labour; the intelligence of the miners in Scotland and Sweden may be referred to as proofs

The miners at Leadhills have a regular library and reading society; and the works they make choice of are not only histories, voyages, travels, &c. but even works of taste, such as the British classics, and best novels and romances. The degree to which knowledge will prevail among any class of labouring men will depend jointly on their own ambition, on the demand for knowledge, or the reputation in which it is held, and on the opportunities of acquiring it. A dull, stupid person, with little native activity, will never desire to know more than what enables him to supply the ordinary wants of life; but where the workmen of any art are required to have technical knowledge of any particular kind, they will be found invariably to possess it. Thus carpenters and masons require some knowledge of the mechanical principles of architecture, and working engineers of the strength of materials; and these kinds of knowledge are acquired by them without an hour's interruption of their daily labour: on the contrary, the habit of evening study renders them more steady, sober, and industrious than other workmen: than bricklayers and paper-hangers, for example, whose employments require much less intellectual skill. If every cook-maid, before she could obtain a first-rate place, were required to be able to read *Apicius* in the original tongue, there would be no want of learned cooks; and if no bailiff could obtain a first-rate situation who had not written a thesis in Greek, or who had not made the tour of Europe, there would soon be found abundance of bailiffs so qualified. A Caledonian, when he comes to the low country, soon acquires the English tongue, and, if he has been taught Latin, thus knows three languages. The servants at the inns on some parts of the Continent, frequented by different nations, often acquire a moderate knowledge of three or four languages: a late custom-house officer on the island of Cronstadt spoke and wrote ten languages; and the bar-maid at the hotel de Londres, at which we lodged in Moscow, in 1814, could make herself intelligible in Swedish, Russian, Polish, German, French, Italian, and English.

7941. *The certain way of obtaining any thing* is to be impressed with the necessity of possessing it, either to avoid the evil of being without it; or to satisfy the desires of others as to ourselves; or our own desires. There is scarcely any thing a rational man can desire that he may not obtain, by maintaining on his mind a powerful impression of the necessity of obtaining it; pursuing the means of attainment with unceasing perseverance, and keeping alive that enthusiasm and ardour which always accompany powerful desires. All may not acquire, by the same degree of labour, the same degree of eminence; but any man, by labour, may attain a knowledge of all that is already known on any subject, and that degree of knowledge is respectable; what many never attain to, and what few go beyond.

7942. *The grand drawback to every kind of improvement* is, the vulgar and degrading idea that certain things are beyond our reach; whereas the truth is, every thing is attainable by the employment of means; and nothing, not even the knowledge of a common labourer, without it: there are many things, which it is not desirable to wish for, and which are only desired by men of extraordinary minds; but let no man fancy any thing is impossible to him, for this is the bane of all improvement. Let no young ploughman, therefore, who reads this, even if he can but barely read, imagine that he may not become eminent in any of the pursuits of life or departments of knowledge, much less in those of his profession: let him never lose sight of this principle—that to desire and apply is to attain, and that the attainment will be in proportion to the application.

SECT. II. *Professional Education of Agriculturists.*

7943. *In order that a professional man should excel as such*, every other acquirement must be kept subservient to that of his profession. No branch of knowledge should be pursued to any extent that, either of itself, or by the habits of thinking to which it gives rise, tends to divert the mind from the main object of pursuit; something, it is true, is due to relaxation in every species of acquirement; but judicious relaxation only serves to whet the appetite for the vigorous pursuit of the main object. By the professional education of agriculturists, we mean that direction of their faculties by which they will best acquire the science and manual operations of agriculture, and we shall suppose agricultural pupils generally to have no other scholastic education than some knowledge of reading, writing, and arithmetic.

7944. *All young men who intend embracing agriculture as a profession*, whether as ploughmen, bailiffs, stewards, land-valuers, or rent-paying farmers, ought to undergo a course of manual labour for one year or more, in order to acquire the mechanism of all agricultural operations. When the pupil is not destined for any particular county, then he should be sent to a farmer in a district of mixed agriculture; as, for example, East Lothian, where he would, if placed in a wheat and bean culture farm, see at no great distance the turnip system and feeding, and a few miles off, the mountain sheep-farming or breeding: when the pupil is intended to be settled in any particular county, he ought to be sent to a county as near as possible of similar soil and climate, where the best practices are in use; as from all the turnip counties, pupils should go to Northumberland or Berwickshire; from the clay counties to East Lothian, or the Carse of Gowrie; from a mountainous district to the Cheviot hills, and Tweeddale, &c.

7945. *The term of apprenticeship* completed, the future time of the pupil ought to be regulated according to the ultimate object in view: if he is intended for a ploughman, shepherd, or hedger, perhaps to introduce new practices in other counties, he may remain for a year or two longer with other masters in the same district, in order not merely to acquire but to habituate himself to all the improved operations and practices. If he is intended for a bailiff, then, after having been two years on one character of farm, let him engage himself for a second two years in a district of an opposite or at least of a different character; and for a third two years, on a third character. There are, as already shown, only three descriptions of farming in Britain: the bean and clover, or clay-land farming, which includes feeding by soiling; the turnip farming, which includes feeding both by soiling and pasturage; and the hill, or mountain, or pasture farming, which includes all the varieties of breeding. A young man therefore of ordinary intellect, who has worked two years in East Lothian on a clay farm, two years in the lower Berwickshire, or in the low part of Northumberland, and two years on the Northumbrian hills, must have a very competent knowledge of that part of agriculture known as farming or husbandry.

7946. *The higher branches of agriculture*, or what may be called the engineering, valuing, and estate-agency departments, can only be completely acquired by first going through the course above described, as suitable for bailiffs and common stewards, and next placing themselves under an eminent steward, land valuator, drainer, road engineer, irrigator, &c. as the case may be; making choice of a steward who has extensive woods and plantations, and also, if possible, some quarries, fisheries, or even mines under his care, and of a land valuer or drainer in full employment. When a solid foundation is laid by a thorough practical knowledge of all the operations of common agriculture, the higher part is attained with ease, and may be practised with confidence; but, on the contrary, when young men who know nothing of common country work are sent direct from school, or from an attorney's office, to a land steward or agent, in order to acquire the art of managing landed estates, the worst consequences may be dreaded, both to the proprietors and the occupiers of the territory which may be subjected to them. The condition of many estates and tenants, managed by attorneys, may be referred to in proof of our assertion.

7947. *Young men intended as rent-paying farmers*, after two years' labour as common servants, should be kept as assistant bailiffs on other farms, till they are at least 25 years of age: no young man, in our opinion, ought to be put in a farm on his own account, or employed as a master bailiff, at an earlier period.

7948. *In all cases when young men are destined for particular purposes*, they should be sent chiefly to particular districts; as, for example, young men intended for road-surveyors, to where roads are best managed, drainers to a draining country, embankers to Lincolnshire, warkers to the Humber, irrigators to South Cerney, hedgers to Berwickshire, woodmen and foresters to Dunkeld, or Blair in Athol, &c. It

would contribute much to the improvement of agriculture in the backward counties, if landed gentlemen would prevail on their tenants to send their sons as apprentices, or even as ploughmen or farm labourers, to the improved counties; or if lads brought up by the parish were sent there with a view to their acquiring the use of the improved implements.

7949. *Whatever is the kind of professional knowledge to be acquired, the means of attainment is the pupil's paying such attention to what he sees and hears as to fix it in his memory.* One of the first things, therefore, that a young man should do is to cultivate the faculty of attention, which he may do every hour of the day, by first looking at an object and then shutting his eyes, and trying whether he recollects its magnitude, form, colour, &c.; whether he would know it when he saw it again, and by what special mark or marks he would know it or describe it. When he goes from one part of the farm to another, or is on a walk or journey, let him pay that degree of attention to every thing he sees and hears, which will enable him to give some account of them when returned from his walk or journey; and let him try next day, or some days afterwards, if he can recollect what he had seen then, or at any particular time and place.

7950. *The attention to be exercised in such a way as to impress the memory, and enable the observer or hearer, not only to recollect objects, but to describe them, must be exercised systematically.* A thing or a discourse must be attended to, not only as a whole, but as a composition of parts; and these parts must be considered not only as to their qualities of dimension, colour, consistency, &c., but as to their relative situation and position. To be able to give an account of a town or village, for example, the first thing is to get a general idea of the outline of its ground-plan, which may be done by looking from a church tower or adjoining hill; next, its relative situation to surrounding objects, as what hills, or woods, or waters join it, and in what quarters; next, the direction of the leading street or streets must be noticed; then the intersecting or secondary streets, the principal public buildings, the principal private ones, where the lowest houses and narrowest streets are situated, and what is the character of the greatest number of houses composing the whole assemblage.

7951. *To treasure up in the mind the characteristic marks of particular varieties and subvarieties of stock is a most important part of an agriculturist's professional education.* To do this effectually, some knowledge of sketching is of great use, and, if possible, ought to be acquired by every person intending to fill the situation of bailiff or steward. The knowledge of soils, plants, and their culture is a very simple business compared with the knowledge of stock, which is not only of difficult and tedious acquirement, but easily forgotten or lost: for one gentleman's bailiff that knows any thing of stock there are at least a score that know nothing.

7952. *In connection with professional studies, the pupil may find it necessary, if his education has been neglected, to go on at his leisure hours with all the usual branches of education, either assisted by books alone, or by books and the best assistance he can procure.* If his school education has extended to arithmetic, mensuration, mathematics, and drawing, he should occupy himself in acquiring a knowledge of botany, zoology, geology, and mineralogy, without a tolerable knowledge of each of which he will ever be in the dark among modern agriculturists, and in reading books on the subject. Next, let him study the various arts and manufactures that have any relation to agriculture, and store his mind with all he can acquire from one of the best general *Encyclopædias*, as that of Rees, or the *Encyclopædia Britannica*, with its excellent supplementary volumes. If he will go farther, and if he wishes to know the extent to which he may go, he may consult what we have advanced on the subject of education in the *Encyclopædia of Gardening*.

SECT. III. *Conduct and Economy of an Agriculturist's Life.*

7953. *A plan for the general conduct of life should be fixed on by every one when he arrives at manhood, and steadily pursued for the time to come: most commonly such a plan is formed by the parents soon after the child's birth, and, at the latest, when the boy is taken from school.* The boy arrived at manhood, however, is entitled to examine this plan, and amend it, or devise another more congenial to his own notions; but the risk of any change of this sort by persons so young and inexperienced is so great, that no youth ought to venture on it without the utmost consideration, and the firmest persuasion in his own mind: where the parent has done his duty, such changes of plan will not often be attempted; for, by the early infusion into the mind of a child of ideas relative to the pursuit that is intended for him, a taste for that pursuit or employment will grow up with him, and become as it were his own natural inclination. This will happen in most cases, but in some children the bias or force of nature for some particular purpose is so strong, that by no parental intreaties or reasoning can it be overcome; even where a sense of duty induced compliance with a parent's wishes for a time, the dormant inclination has at last broke out and taken the lead. In such cases, the parent may generally conclude, that where the pursuit or purpose is not bad, the force of natural inclination will be more likely to command success than the influence of parental authority; and that a pursuit or business, commonly of little profit or repute, will be more profitable and respectable when followed by a genius powerfully impelled to it, than a profitable and reputable business followed by any one against his inclination.

7954. *The plan and conduct of life are in most cases determined by accidental circumstances.* The son of the labouring man grows up without any regular training or education for a particular end, and finds himself at the age of manhood engaged in rural labour, and apparently incapable of any other; his notions and his ambition are so limited that he dare not venture to desire a change for the better; for no man ever desires that which he thinks it impossible to attain, and the mere idea of this impossibility, however erroneous, effectually restrains the attempt at improvement. The life of the ploughman or labourer, much as it differs from that of a man of eminent natural powers and superior education, is capable of much amelioration by being directed to a suitable end or object as the ultimatum, or in other words, by proceeding on a plan; plan indeed, as we have elsewhere observed (*Encyc. of Gard.* 2d edit. 7778.), is predestination, as conduct is fate.

7955. *The greater part of mankind enter on life without any fixed plan or object in view, or, if they have some general notion of acquiring wealth or distinction, they form no plan by which it is to be accomplished; the consequence is, that such persons, after blundering on through their best years, arrive at the end without having gained any thing but experience, now of no use to them.* No man is born in possession of the art of living, any more than of the art of agriculture; the one requires to be studied as well as the other, and a man can no more expect permanent satisfaction from actions performed at random, than he can expect a good crop from seeds sown without due regard to soil and season. When we look round and observe the quantity of misery in the world, the greater proportion is, or seems to be, the result of a want of plan, or of a bad plan of life. How many parents are unsuccessful in their struggles to maintain a large family, the result of too early marriages: how many find themselves arrive at old age with no other resource for support but charity, the consequence of want of foresight in expenditure: how many are suffering under poverty, brought on by their own want of frugality, or positive extravagance; or under disease from excesses and irregularities committed in the heyday of life: and how many among those not born to inherit property, who, at no period of their life, have any other alternative between hard labour and deficient food, than disease and want!

7956. *Want of plan may not in every case be the cause of all this misery, because accident enters into life for something, both on the unfavourable as well as the favourable side of the question; but we have no hesitation in asserting, that want of plan, as a cause of misery, is as ninety-nine to a hundred: any plan at all, even a bad plan, is better than none; because those who set out on any plan will, in all probability, sooner discover its errors if a bad one, and correct them, than those who set out on no plan will*

discover the want of one and form a good plan. The young man who is just setting out in life may well tremble at the consequences of proceeding on the journey without the guide of a judicious plan; this plan he must form himself, because he alone feels what he wants, and what he can do to gratify them; all that we can do is to offer a few hints.

7957. *In order to be able to form a plan* it is previously necessary to determine the object to be attained by it. Happiness is the object of every action of human life, and consists in the gratification of certain wants and desires: some of these desiderata are peculiar to youth, and others to old age; but many, as clothing, food, rest, relaxation, entertainment, &c., begin with the earliest, and continue to the latest period of life. All these gratifications are procured by labour; in savage life, by hunting, fishing, and gathering fruits, till the man, no longer possessing strength enough for these labours, is obliged to lie down and die of want: in civilised society, they are also obtained by labour; but here what is called property exists, and man, in the vigour of his days, when the supplies of his labour are greater than the demands of his wants and desires, or when he chooses not to gratify the latter to the full extent admitted by the former, can, as it were, embody a part of his labour, to be made use of when he is no longer able to perform it with ease: a man in this case is said to arrive at independence, instead of want, as in the case of the savage, or of beggary, as in the case of the improvident.

7958. *Independence is the grand object* which every man destined to live by the exercise of his labour or talents ought to have in view. At certain periods of life, when the imagination is vivid, and health and animal spirits in their utmost vigour, some may prefer present enjoyment, mere animal gratifications, or imaginary distinctions, amatory conquests, titles, rank, military glory, and high literary or professional reputation: it is a noble attribute of our nature to prefer some of these to the mere accumulation of money; but a great warrior, poet, or painter, arrived at old age and want, if the latter be brought on by common improvidence, will not find himself surrounded by many marks of distinction; and though it may possibly be some consolation to him that the three or four letters composing his name will be sometimes pronounced together after he is dead, yet it will not be much.

7959. *The exercise of his profession* is the most rational mode in which an agriculturist, of whatever grade, can pursue independence. Only extraordinary circumstances can justify a change of profession; in common cases it indicates a want of steadiness of character, or a want of success, and the latter is commonly attributed to want of skill; it is better, therefore, to pursue unremittingly the profession to which we have been educated, even though we should not be very successful in it, than to risk an infringement on character by adopting another. The practice of agriculture, as we have already seen, (7710.) is carried on by three different classes, serving, commercial, and artist agriculturists: on each of these classes we submit a few hints to aid them in forming a plan of life, and regulating their expectations.

7960. *The greater number of agriculturists must ever belong to the lower grades of the serving class*; and act as ploughmen, herdsman, shepherds, hedgers, woodmen, and labourers of all-work. These form the greater proportion of mankind in every civilised country, and must ever remain the bulkiest material in the social fabric. Comparing one age and country with another, however, there may be the greatest difference in their intellectual and physical condition. The ploughman of Russia is but a remove from his horse. The ploughmen in different parts of Britain are as intelligent as their employers: in Scotland they have the Bible by heart, are familiar with the history of their country, and not ignorant of its literature; they lead a laborious life, but they enjoy the inestimable blessings of health, sound sleep, and peace of mind, till the latest period; they are almost always independent, either from their labour, their savings, or, in old age or sickness, from the assistance they receive of their children in return for what was laid out on their education. These men are as happy, relatively to their capacity for happiness, as any other class whatever: if their measure is smaller, it is as full as the largest; for the essential materials of comfort and happiness are the same in all classes, and in all classes a man's wants and wishes accommodate themselves to the means of gratifying them. The rich have no wants, and their desires for the most part are no sooner expressed than gratified; the pains and pleasures of life are neutralised into a kind of insipidity, till ennui brings on disease, which to this class becomes a blessing, by procuring for them the occupation of taking medicine, the duty of attending to the doctor's regulations, and the pleasures of convalescence.

7961. *Constant labour*, even that of the humblest description in the country, when it is not oppressive, and where it is accompanied with abundance of food, sufficient clothing, and good health, is by no means inconsistent with happiness. It is a common but most erroneous idea, that happiness is confined either to the rich or the independent. Health and activity are the woods, and a rich man who has nothing to do is unquestionably more miserable than any ploughman in the empire. "Happiness," says one who has thought much on the subject, "is the full and vivid satisfaction of the mind; and it consists in content and uninjurious enjoyment, that is, enjoyment not injurious either to oneself or to any other. Among the very first requisites to this satisfaction, it will readily be perceived, is employment, either bodily or mental; and the more energetic, without exhaustion, is the employment, the more full and vivid will be the satisfaction. The human mind is naturally active; and, except in sleep, if even then, cannot with impunity be motionless or torpid. Occupation is as necessary to its health as circulation of the blood is to the body's. Employed it must be, to know content or feel enjoyment; for, by any want productive of pain, either bodily or mental, especially the latter, content and enjoyment are, according to the degree of the pain, destroyed or diminished; and the want, which the unemployed mind invariably feels, is as invariably productive of uneasiness, of listlessness, and lassitude, and their inseparable attendant, mental pain. Indeed this pain is, not unfrequently, altogether unendurable. 'All the importunities and perplexities of business,' says Dr. Johnson, 'are softness and luxury compared with the incessant cravings of vacancy and the unsatisfactory expedients of idleness.' 'It is this intolerable vacuity of mind,' says Paley, 'which carries the rich and great to the race-course and the gaming-table.' It is this vacuity, says experience, which often arms them against themselves, and hurries them to self-destruction. If, also, employment is necessary to the health of the mind, exercise is to that of the body. Employment to the mind and exercise to the body are in some degree substitutes for each other; but, for the full content and enjoyment which constitute happiness, they both, in due proportion, are necessary." (*Co-operative Magazine*, vol. i. p. 6.)

7962. *The plan of life suitable for the operative agriculturist* may very well be founded on the condition of this class of men in the northern counties of Northumberland, Berwickshire, East Lothian, and others. We have already (7809. and 7834.) described in general terms the manner in which farm servants are hired, lodged, and paid in these counties; and details by an eminent Northumberland farmer will be found in the sixth volume of the *Gardener's Magazine* (p. 589.). The essence of the mode consists in the employer providing the employed with comfortable cottages and gardens, and paying them chiefly in the necessaries of life, in so much meal or flour, so much ground to grow potatoes and flax or hemp, a cow's keep, the run of a pig, if a shepherd so much wool or so many sheep, the loan of a team to bring home coal or other fuel, and a certain proportion of money. By this mode of payment the operative countryman is always sure of a comfortable home and food, sure of milk, butter, meal, bread, and potatoes, the produce of a pig, poultry, and bees, and of the produce of his garden; and this, however high may be the prices of these articles in the public market. These good things can only be rendered nugatory by the evil of a bad wife. All country servants hired by the year might be accommodated and paid more or less in this manner; and to this mode of life and payment they ought to look forward as the ultimatum of their grade in the scale of operative agriculturists. By prudent conduct, in regard to the increase of their family, and by frugality, they may live in decency and comfort, educate one or two children, and save something for old age, or unforeseen occurrences.

7963. *The Northumberland ploughman* is the happiest of labourers, and never feels a bad season. His wages are certain; and with frugality and care, his wife may bring up a large family upon this income. The reverse is sometimes the case; but this is attributed to a bad wife, who wastes the produce of the cow. The small stock of the hind being always his own, and the cow generally so, makes him prudent and careful during single service to save as much of his wages as will set him up for himself. To this, and the fact that the wages of labour are never paid out of the poor's rate, the enviable state of the Northumbrian labourer is to be attributed. It appears to operate as a preventive check upon population, and beautifully illustrates Mr. Malthus's theory; or, in the words of Burns, it teaches them to "know that prudent cautious *self-control* is wisdom's root." They are all anxious to give their children such education as they can command. When they are within the reach of a charity-school they thankfully avail themselves of it, and we find in every hamlet some person who teaches the younger children the rudiments; and several of these, when they get older, work and save the wages of summer to pay for putting themselves to schools in winter. (J. C. in *Gard. Mag.* vol. vi. p. 591. See also *Denson's Peasant's Voice.*)

7964. *The day labourer who has no particular employer*, and probably no fixed residence, is much less comfortable than the yearly servant; in England more especially, under the present system of poor laws and parish management, which is calculated to degrade him, and effectually to prevent any attempt at improving his condition. If, as Slaney observes, "by unremitted industry, he has been enabled to do without parochial relief, and bring up his children decently, it is as much as could be expected; for an attack of illness, or the temporary loss of employment, he is in general totally unprepared; he thinks not much of the morrow, and, as it stands, it is perhaps well for him that he does not anticipate evils which he cannot prevent. Every one knows how beneficial to the community, how advantageous to the individual, the hope of bettering his condition in life is: it cheers him in adversity, encourages his industry, promotes his content, yet from this hope the major part of the agricultural labourers of England are excluded; they toil indeed, but it is to continue, not to better their existence." (*Essay on the beneficial Direction of Rural Expenditure*, p. 170.; see also the succeeding chapters of these judicious and intelligent essays.)

7965. *The condition of the labouring classes* has lately been considered by the editor of the *Scotsman*, in an article in his xivth volume (Nos. 1131, and 1132.), which is also published separately in a tract entitled *The Scotsman's Advice to the Labouring Classes*. The condition of the labouring classes, it is observed in this tract, may be deteriorated in two ways; "by increasing their numbers too rapidly, and by diminishing the capital which provides them with employment. Now capital is either diminished, or its natural growth is impeded, by the enormous sums paid to the government, by the tax on corn imposed for the benefit of the aristocracy, and by the many absurd restrictions on industry, which have arisen from the ignorance or misconceptions of our legislators. To repeal or reduce taxes, and relieve industry from the restrictions which fetter it, benefits the working classes by enlarging the fund which creates a demand for their labour. The sufferings of these classes are therefore, in no small extent, imputable to the exactions and misconduct of the government. Culpable and injurious, however, as the extravagance of the government has been, I am convinced that were all the public burdens annihilated, and all the obstacles to freedom of industry removed, the relief given would be but temporary. The misery of the working classes might be mitigated by such means, but it cannot be eradicated by legislation, nor by any human means except such as shall put some check on the increase of their numbers. Scientific thinkers regard this conclusion as established on the clearest evidence; how then is the principle of increase to be checked? Only in one way: by enlightening the minds of the working classes; by inspiring them with feelings of self-respect; by teaching them the immense importance of habits of prudence, forethought, and self-control to their own happiness; by giving them true notions of their situation as moral agents, responsible for the consequences of their acts, and endowed with powers which, if rightly used, would make them to a great extent masters of their own destiny."

7966. *A radical evil in human conduct*, is that "in the article of marriage men consider life as a *lottery*, and they rush into the most important of all ties, without making any provision for discharging the obligations it lays upon them. This applies to the middle ranks as well as to the lower." Thousands and tens of thousands marry every year whose earnings hardly suffice for their own subsistence; and multitudes throw their offspring on the world "with as little rational consideration about its future well-being, as the crocodile shows when she drops her egg in the sand, and leaves it to the sun and the winds to hatch her young into life." Such persons shelter their thoughtless conduct under the plea of trusting to Providence: but what is trusting to Providence but trusting to chance? Nature has endowed us with reason to regulate our conduct, and in most of the common concerns of life has enabled us to foresee the consequences of our acts. After making all the use of our reason that we can, enough will still be left for chances, which may turn out, as every day shows, as much against us as for us. "To neglect the admonitions of reason, and then trust to Providence to free us from the evils induced by our own thoughtlessness, is to call upon the Deity to work a miracle in our favour; and this, instead of promoting our improvement, is only to harden us in our folly."

7967. *There are two truths of vast importance* to the well-being of the labouring classes; the first is, that as no efforts of legislation can lift them out of their misery, their happiness must always depend on their own habits of prudence, forethought, and self-control. The second is, that no man has a right to bring human beings into the world, who is not able to provide for their support and education. The law punishes severely the act of exposing a child; but the man who marries and becomes the father of children, without having any reasonable prospect of being able to keep them from beggary with all its attendant miseries, is guilty of the same crime in a lower degree.

7968. *To convert the burthens which marriage brings with it into money*, the *Scotsman* suggests the following scheme: he takes the case of an industrious mechanic beginning to earn 16s. per week at the age of eighteen, and he shows what he could accomplish by living economically, and deferring marriage till he was twenty-eight: he supposes him able to live upon 12s. 6d. per week, and to place 3s. 6d. per week in a savings' bank, by which his stock, including interest, will amount in ten years to about 100l. At his marriage he is supposed to spend 50l. of this 100l. in furnishing a house, &c. and to dispose of the remaining 70l. to provide against the following casualties.

7969. *The first casualty after marriage* which he has to provide against is sickness, which may be done by a weekly contribution of 4d. for himself and his wife.

7970. *The second casualty* is the infirmity of old age. This is to be provided against by an annuity from government, or a benefit society; and 17l. 1s. 9d. paid at once, or an annual payment of 9s. 6d. by a man at the age of twenty-eight, will obtain an annuity for him of 20l. per annum for whatever number of years he may live beyond the age of sixty-eight.

7971. *The third casualty* to be provided for is the possible widowhood of his wife: this he may do by paying down 32l. 12s., for which a man of twenty-eight may secure for his wife, supposing her age to be the same, an annuity of 10l. for life, in the event of her being left a widow, at whatever period it may happen. On this subject the benevolent and philosophic author of the scheme observes, "When society is more enlightened, it appears to me that a provision against the chance of widowhood will be considered as indispensable at marriage as a suit of wedding clothes.

7972. *The fourth casualty* is the chance of the death of the father before his child is able to shift for itself; that is, before it is fifteen or sixteen years of age. To ensure each child against this casualty, it is proposed to secure a small annuity to it in the event of his death, of say 3s. per week, up to its fifteenth year. This, the father being aged thirty, he calculates may be purchased for 5l. paid down the first year of the child's life. "A similar deposit of 5l. would be requisite at each addition made to the family; and as a marriage is assumed to produce on an average four children, the whole sum expended under this head would be 20l." Those who have more than four children must make extraordinary exertions.

7973. *A reasonable degree of security against the casualties of life* may be afforded to a working man about to enter into the married state and his family for the sum of 100*l.*, which it is shown he might save by the age of twenty-eight. That sum would be disposed of thus :

Furniture, exclusive of what was provided by the wife	-	-	£30
Annuity for himself in old age of 20 <i>l.</i> per annum	-	-	17
Annuity of 10 <i>l.</i> per annum for his widow	-	-	33
Provision for four children	-	-	20
			£100

Therefore, let no man whatever, not even the most humble country labourer, think of marrying before he has saved 100*l.* ; and let him beware of spending any part of this sum, even that part which is allotted for his furniture, before he has provided for the four casualties of the married state.

7974. *To carry this scheme into effect*, mutual assurance societies by the working classes themselves, or benefit societies, would probably be the best mode, and government and the more wealthy members of society ought to lose no time in assisting in their formation. It is justly observed, however, that it cannot be too often inculcated upon the working classes, that the improvement of their condition must be their own work. Were this scheme carried into practice, "it would diminish their numbers relatively to capital, and as a consequence, *their wages would rise*. Secondly, it would rescue them and their families from extreme poverty, give them independence of character, secure to all of them the advantages of education, and thus break down the barrier which confines them to the sphere they are born in, and precludes them from obtaining any of the higher prizes in the lottery of life. To society the system would be equally beneficial: poor's rates, with all the abuses they engender, would be done away; crimes would be rare when pauperism was eradicated; and by the universal diffusion of education, all the talent in society would be made available. And last, not least, when every grown-up man had either a small stock of savings in hand, or investments in a common fund, we should have the very best guarantee for the public tranquillity. Did the working classes fully understand this scheme," its excellent author continues, "nine tenths of all the poverty, misery, and crime which we see around us would disappear; we should in fact find ourselves in a new world, full of intelligence, peace, and good order, in which life and property would be ten times more secure, happiness more equally distributed, and an admirable foundation laid for the further amelioration of the lot of mankind." (*Scotsman*, Nov. 13. 1830.)

7975. *The plan of life for the directive class of agriculturists* need hardly be pointed out; the rise from a farm bailiff to a steward's bailiff, or to a demesne bailiff or steward, and thence to the general steward or factor of an estate, is an obvious object of ambition. In another direction he may rise through the different gradations of the commercial agriculturist, or, adopting the rank of counsellor or artist, he may become a salesman, appraiser, timber or land-surveyor, land-valuer, agent, or agricultural engineer: rarely, however, can he attempt the veterinary profession, or that of draftsman, author, or professor.

7976. *The remuneration to which a directive agriculturist is naturally entitled*, should be regulated by his professional abilities and experience; that which he will commonly receive will be regulated by the quantity of agricultural talent and experience in the market; it ought always to be such as will render it worth his while to be honest, assiduously attentive to the interest of his employer, and of polite and obliging manners. A handsome salary to such a servant is wise economy.

7977. *The object of the artist or counsellor agriculturist* may be either to ascend to the rank of author or professor, conditions of more honour than profit; or to realise property and become a proprietor cultivator. For a rent-paying farmer, no artist or author is at all adapted.

7978. *The legitimate object of a commercial agriculturist* is to rise in the different grades of his class, and become either a large farmer, a gentleman farmer, or, best of all, a proprietor cultivator.

7979. *The profits to which a commercial agriculturist is entitled*, comparatively with those of other commercial men, are theoretically determinable by the risk attending the employment of his capital, and the skill requisite to prosecute his art; but, practically, this remuneration will depend on the quantity of skill and capital in the market. The risk attending capital employed in the culture of the useful products of the soil, is evidently less than the risk of capital employed in many or perhaps most manufactures; and the skill requisite to enable any one to become a farmer, according to the customary practices of the country surrounding him, is less than that required for almost any branch of manufacture. In consequence of these things, there are men every where ready to become farmers; hence the profits of farming are naturally less than those of most other pursuits; but, to counterbalance this, the farmer has several advantages peculiar to his profession. First, the nature of his residence in the country, which assumes a certain degree of consequence from its connection with a considerable group of out-offices, surrounded by a garden, orchard, fields, woods, and other rural scenery, all in his occupation, and inhabited by servants in cottages, horses, cattle, sheep, and other domestic animals, in subjection to him, gives him a degree of consequence both real and apparent; and assimilates him more nearly to a lord of the soil, and to the possessor of that sort of rural retirement and independence which is the object of almost every commercial man's ambition, than any other mode of life could do. Secondly, many trades and professions preclude (according to general prejudices) their followers from being gentlemen: whereas, though every farmer is not a gentleman, yet any gentleman may become a farmer, without in any degree lowering his rank and character; a farmer may, therefore, if he chooses to adopt the habits and manners of a gentleman, be reckoned as such. Thirdly, the farmer's products are in universal demand, and he is sure of a market at some reasonable rate, a fact otherwise with many manufactures. Fourthly, he is sure of a home, of the necessaries of life, and, in general, of most vigorous health. Fifthly, he is generally a man of more parochial influence than the tradesman or manufacturer.

7980. *Scarcely any farmer makes a fortune by his profession*: the utmost exertions of the most skilful and industrious men, in the most improved districts, seldom do more than enable them to keep pace with the times; and the great majority, in all countries, lead a life of great labour and anxiety, and end as they began. No farmer, in a general way, can raise more than one corn crop in a year, and in this respect the farmer of Russia and Poland has the advantage of the British farmer; for the lands of the former being from five to eight months under snow, all root-weeds are destroyed, and the ground so loosened by the frosts and thaws, as to require very little stirring for the seed: the rapid summer which succeeds ripens all annual plants that will grow there, nearly as well as in England, and better than in many parts of Scotland and Ireland. The British farmers, however, have the great advantage of perpetual pastures, owing to the mildness of our winters; but still no art of man will shorten the period of animal gestation, and originate a lamb or a calf in shorter periods than five months and forty weeks. How often does the tradesman or manufacturer turn his capital in that time! There are three varieties of professional farmers, however, who occasionally realise some property: the grazier who feeds with oil-cake, grains, and other artificial foods; the dealer in corn or cattle, who has the art to buy at a falling and sell at a rising market; and the dealer or jobber in farms, who sublets or sells his lease, or in purchases of land, who subdivides and sells estates. The profits of the first are not great, and those of the last two are attended with great risk: the only farmer whose lot is to be envied, lives under a landlord who does not take the full marketable price for his lands: such as Burdett, Coke, Bedford, Northumberland, and many others in the south; but few in the north, or in the west.

CALENDARIAL INDEX.

THOUGH agricultural operations, in general, require less nicety as to the exact time of performing them than many of those of gardening, yet there are exceptions in respect to some field crops; for example, beans and turnips. It is proper to observe, therefore, that the *almanac time* in this Calendar is calculated for the meridian of London; but as a *Calendar of nature* is given for the metropolitan district, the almanac time may, in every part of the empire, be varied to suit the local climate and vegetation.

In general, other circumstances being alike, four days may be allowed for every degree, or every 70 miles north or south of London; in spring, operations may be commenced earlier in that proportion southwards, and later northwards; but in autumn the reverse, and operations deferred as we advance southwards, and accelerated as we proceed to the north. In every case allowing a due weight to local circumstances.

Our notices under each month extend only to a few of the leading features of country-work; — to attempt to insert every thing, or even most of the things that require attending to, we conceive impossible; and, if it could be done, quite useless. A man will always act better when guided by his own judgment, than when following implicitly that of another. Calendars should only be considered as remembrancers, never as directories.

JANUARY.

Weather at	Average of the Thermometer.	Greatest Variation from the Average.	Average of the Barometer.	Quantity of Rain.	REMARKS.
London -	35 9	6	29 56	1.957 inch.	A cold January is reckoned seasonable; the air being drier during a low state of the thermometer than when it is a little above or below the freezing point; winter-cold is generally less felt by animals than that of March. Winds often prevail during this month. The calendar of animated nature is much more to be depended on than the vegetable calendar; for except the catkins on trees, the state of the other plants during this month depends much on the character of the preceding autumn.
Edinburgh	34 5	- -	29 194	2.994	
Dublin -	39 92	- -	29 721	2.697	

1. Calendar of Animated Nature round London.

In the first week: shellless snails (*Hélix*) and earth-worms (*Lumbricus terrestris*) appear.

Second week: redbreast (*Motacilla Rubicola*) whistles, nut-hatch (*Sitta europæa*) chatters, missel thrush (*Turdus viscivorus*) sings, and wagtails (*Motacilla alba et flava*) appear.

Third week: the common lark (*Alauda arvensis*) congregates.

Fourth week: snails (*Hélix hortensis*) and slugs (*Limax ater et hyalinus*) abound in the sheltered parts of gardens; the hedge sparrow (*Motacilla modularis*) whistles, the large tit-mouse (*Parus major*) sings, and flies appear on windows.

2. Calendar of Vegetable Nature round London.

In the first week: some plants accidentally in flower; and others, as the Laurustinus, continued from December.

Second week: winter aconite (*Eránthis hyemalis*), Christmas rose (*Helleborus fœtidus*) in flower, and hazel (*Corylus Avelana*) catkins beginning to appear: common honeysuckle (*Lonicera Periclymenum*) buds begin to appear.

Third week: primrose (*Prinula vulgaris*) flowers in sheltered places; daisy (*Bellis perennis*) and chickweed (*Alsine media*) begin to flower.

Fourth week: mezereon (*Daphne Mezereum*) begins to flower; and sometimes spurry (*Spergula arvensis*), pansy (*Viola tricolor*), white scented violet (*Viola odorata*), archangel (*Lamium rubrum*), and coltsfoot (*Tussilago purpurea et odorata*) show blossoms.

3. Farm-yard. (2902)

Attend to cattle, whether in the open yard on straw and a few turnips (5411.), in hammels for feeding (6855.), or in stalls (6852.). See that the weak are not driven from their proper share of green food by the strong; notice any in bad condition, and put them in a place by themselves for a few weeks. When the hay or straw is of inferior quality or flavour, sprinkle with salt water, which will make it more palatable.

Threshing (3199.) goes on pretty regularly at this season for the sake of a supply of straw. In some districts it is common to thresh an hour every morning by candle-light during the three winter months, the candles being hung up in lanterns. See that the gudgeons and other places are kept oiled, and the teeth of wheels greased or soaped, or coated with anti-attribution.

Implements not now in use may be repaired, also harness greased, ropes spliced, and various evening jobs executed, where it is customary to work a part of the winter evenings.

Men's lodge. (4160.) In some districts the unmarried farm-servants have a common living-room in the farmery, with a sleeping-room over, or sleeping-rooms over the horses. It is the duty of the farmer or bailiff to see that these young men are properly occupied during the long winter evenings. A portion of every man's time will be taken up in mending his clothes or shoes, and sometimes in oiling and cleansing horse harness; the rest they ought to be encouraged to pass in reading, or otherwise instructing themselves. One may read aloud

to the rest; one may instruct the others on any subject; a master may be got in for an hour or two every evening, who would teach them all. A master suitable for this purpose will often be found among the married servants, or among the village mechanics. To serious studies may be joined recreative ones, such as the flute, violin, story telling, singing, speech-making, dramatic attempts, &c. The bailiff or farmer should occasionally come and examine each lad, and bestow some mark of approbation on the most deserving.

4. Live Stock. (6216.)

Store farms (7191.), whether of sheep or cattle, require considerable attention during the winter and spring months to supply straw and hay, with such green food as can be spared, to stock on scanty pastures; and to shelter during storms, especially of snow.

Lambs are dropped during this month by the Dorset sheep, and near London are generally kept in the house and fed. (7224.) These require regular attention.

Calves fattening at this season (6843.) should be kept very clean, and their supplies of milk liberal. Calves to be reared as stock should never be dropped sooner than April.

Pigs (7285.), *poultry* (7458.), and stock in general, should be kept in good heart at this season, otherwise in the spring months they will be fit for nothing, and half the summer will elapse before they recover the bad effects of winter starvation.

Fish, when the ponds are covered with ice, require attention, to break holes to admit air. (7572.)

Bees if dormant do not require to be fed; but if the weather is so mild, or they are placed in so warm a situation as to occasion their flying about, they should be examined, to ascertain if feeding be requisite. (7602.)

5. Grass Lands. (5643.)

Dry soils and uplands should alone be stocked with cattle or young horses at this season. (5839.) Sheep should not be allowed to graze either on wet marshy meadows or on young clovers. (5543.) Grass lands, under a system of irrigation, may now be kept covered. (4387.) Clayey soils and others not properly drained should now have that operation effectually performed on the surface (4294.) or under it (4282.), according to circumstances.

Worms (7704.) on some soils do considerable injury to grass. Where the labour is not considered too much, and there is a water barrel at any rate, they may be killed by mixing powder of lime with the water, at the rate of one pint to ten gallons. On lawns, and in small paddocks, or in the case of *fermes ornées*, getting rid of worm casts is an object worth attending to; and this month, February, and October, are the best seasons for the operation.

6. Arable Lands. (4925.)

Plough when the soil is not too wet. Lead out dung and form field dunghills, also compost heaps, with peat or other matters. See that drains, ditches, and water-furrows run freely, and answer their respective ends.

Beans (5222.) are in some dry situations planted in the last week of the month; and also peas, and sometimes oats, are sown. On the whole, however, it is better to defer the beans and peas till the first and second weeks of February, and the oats till the two last weeks of that month.

Spring wheat of the common kind (5025.) may be sown where the soil is suitable.

7. Fences (2960.), Roads (3523.), and Drains. (4213.)

Hantheorns may be planted in fence-lines, in any of the different modes. (2972.) Ditches, walls, palings, and all other fences of the common kind may be formed; but none where hollies or other evergreens are to be used. Repair by the different modes. (2987.) Roads and drains may be formed at all times and seasons.

8. Orchards (4079.) and Hop-grounds. (5997.)

Prune trees and free them of moss. Where digging round each tree is practised, this is a good season. Stake and tie newly planted trees. Plant orchards. Trench ground for hop plantations. (6007.)

9. Wood-lands and Plantations. (3906.)

Prepare the soil for planting. Plant deciduous hard-wooded trees in mild weather. Plant and sow the larger tree seeds, whether in places where they are finally to remain, or in nursery-grounds.

Fell timber and coppice not valuable on account of its bark. Stock up roots, stack them, and char them.

Prune deciduous trees; fill up vacancies. Cut hawthorn hedges. (2983.) Gather any tree seeds not before gathered.

Drain wood-lands and cut paths or other openings required through them, the leaves being now off the deciduous sorts.

FEBRUARY.

Weather at	Average of the Thermometer.	Greatest Variation from the Average.	Average of the Barometer.	Quantity of Rain.	REMARKS.
London -	42 3	5	29 94	0.875 inch.	This month (the <i>spring</i> or <i>sprout kale month</i> of the Saxons) is usually subject to much rain or snow; either is accounted seasonable: the old proverb being, "February fill dike with either black or white." Round London, the sap in vegetables shows evident symptoms of motion about the middle of the month, and sometimes a week earlier. The animal calendar, and inflorescence of native trees for this month, will generally be found very correct.
Edinburgh	36 6	- -	29 556	1.269	
Dublin -	43 78	- -	30 091	2.24	

1. Calendar of Animated Nature round London.

In the first week: bees (*Apis mellifica*) come out of their hives, gnats (*Culcx*) play about, insects (*Insécta*) swarm under sunny hedges, and the earth-worm (*Lumbricus terrestris*) lies out; hen-chaffinches (*Fringilla*) flock, and the song-thrush, or throistle (*Turdus musicus*), and common lark (*Alauda arvensis*) sing.

Second week: the buntings (*Emberiza álba*), and linnets (*Fringilla Lindta*), appear in flocks; sheep (*Ovis Aries*) drop their lambs; geese (*Anas Anser*) begin to lay.

Third week: rooks (*Corvus frugilegus*) begin to pair, and resort to their nest-trees; house-sparrows (*Fringilla domestica*) chirp, and begin to build; the chaffinch (*Fringilla cœlebs*) sings.

Fourth week: the partridge (*Tetrao Pêrdix*) begins to pair, the blackbird (*Turdus Mèrula*) whistles, and the wood-lark (*Alauda arvensis et arborea*) sings; the hen (*Phasianus Gallus*) sits.

2. Calendar of Vegetable Nature round London.

In the first week: the snowdrop (*Galánthus nivális*), whin (*Ulex europæa*), white deadnettle (*Lamium álbum*), polyanthus (*Primula veris*) flowers; and the elder (*Sambucus nigra*), and some roses and honeysuckles, begin to expand their leaves.

Second week: common crowfoot (*Ranunculus repens*), dandelion (*Léontodon Taraxacum*), and the female flowers of hazel (*Corylus Avellana*) appear.

Third week: *Verónica agréstis* in flower; many of the poplar and willow tribe show their catkins; and also the yew (*Taxus baccata*), alder (*Alnus communis*), the tulip (*Tulipa*), crown imperial (*Fritillaria imperialis*), and various other bulbs, boldly emerging from the ground.

Fourth week: the Erica cárnea, wood strawberry (*Fragaria vesca*), some speedwells (*Verónica*), the groundsel, and sometimes the stocks and wall-flower (*Cheiránthus*) in flower. Some sorts of gooseberries, apricots, and peaches, beginning to open their buds.

3. Farm-yard. (2902.)

See last month. In taking in stacks to thresh, destroy vermin as much as possible. (6632.) Clear away the bottoming of straw, faggots, or other temporary matter, and leave the site perfectly neat and clean: the poultry will pick up what grains may have dropped. Be vigilant in keeping stock of every description in order; wintering cattle by frequent supplies of fresh straw and turnips, or other roots; horses by sound corn, and good peas-straw, or clover-hay, dispensing as much as possible with wheat and oat straw. The evening food should, occasionally at least, be of carrots or potatoes.

Poultry now lay freely; and if some indicate a desire to incubate, so much the better where an early brood is an object.

Men's lodge. There are still a good many hours for mental improvement.

4. Live Stock. (6216.)

Sheep generally begin to lamb during this month, and re-

quire unremitting attention from the shepherd. (7112.) Attend to feeding lambs as before (7224.), and to milch cows (6863.) and fattening calves. (6843.)

5. Grass Lands. (5643.)

See last month. Manures, where applied to grass lands, may be laid on at this season; and such old mossy lands as are to be broken up may now be pared with a view to burning next month.

The watering of meadows in warm situations may be partially left off towards the middle of the month, to encourage the growth of the grass. (4585.)

6. Arable Lands. (4925.)

Beans should be put in during this month. (5222.) Peas for podding, and for a ripened crop, may be sown at different periods (5121.), and tares for soiling or seed. (5257.) Oats sown from the middle of this month to the middle of March (5120.) unless on very old turf, where they may be sown later. It is a common but erroneous opinion, that old grass lauds intended to be broken up and sown with oats or beans, should be ploughed as early as possible, so as the frost may have some effect on the furrow before seed-time. But this, though most plausible, is a most dangerous doctrine, it being found from experience, that lands so ploughed and sown are always more subject to have the plant of corn destroyed by the grub, wire-worm, or other larvæ. The only safe mode with such lands, is not to plough them till about the middle of March, and then to plough, sow, and roll immediately afterwards. It would appear that by this practice the larvæ of insects are buried so deep, that they have not time to reach the surface before the grain has germinated and grown out of the reach of their attacks, or probably they may be so deeply buried as to be obliged to remain another season under ground; it being known to naturalists, that the eggs, larvæ, and chrysalidæ of many insects, like the seeds of many plants, will, when buried too deep, or otherwise placed in circumstances not favourable for their immediate hatching or germination, remain there, retaining their principle of life, till they can make their way, or are by accident placed in circumstances favourable for their development. The safest plan, however, to break up old grass land is to pare and burn. (5865.)

Spring wheat of the common kind may now be advantageously sown (5004.), and barley is also sown in some warm spots in the last week of the month.

7. Fences (4213.), Roads (3523.), Drains, Ditches (2960.), Ponds. (4467.)

Hedges may be planted (2978.), grown ones pruned (2981.), old ones plashed or cut down (2987.), and imperfect ones repaired. Walls built (5056.), water fences and ponds formed. (4467.)

8. Orchards (4079.) and Hop-grounds. (5997.)

See last month.

9. Wood-lands and Plantations. (3906.)

As in last month. Where there is a nursery store, nut and kernel tree seeds may now be sown.

MARCH.

Weather at	Average of the Thermometer.	Greatest Variation from the Average.	Average of the Barometer.	Quantity of Rain.	REMARKS.
London -	46 4	4	30 20	0.716 inch.	The beginning of March usually concludes the winter; and the end of the month is generally indicative of the succeeding spring; according to the proverb, "March comes in like a lion, and goes out like a lamb." The Saxons called this month the <i>lengthening month</i> , in allusion to the increasing of the days. This is a laborious and trying month, both for men and cattle engaged in field operations.
Edinburgh	41 7	- -	28 886	1.455	
Dublin -	44 09	- -	29 707	2.564	

1. Calendar of Animated Nature round London.

In the first week: the ring-dove (*Columba Palumbus*) coos; the white wagtail (*Motacilla álba*) sings, and the yellow wagtail (*Motacilla flava*) appears. The earthworm (*Lumbricus terrestris*), and the snail (*Hélix*) and slug (*Limax*) engender.

Second week: the jackdaw (*Corvus Monédula*) begins to come

to churches; the tomtit (*Parus cæruleus*) makes its spring note; brown wood-owls (*Strix U'lula*) hoot; and the small tortoise-shell butterfly (*Papilio urticæ L.*) appears.

Third week: the marsh titmouse (*Parus palustris*) begins his notes. Various flies (*Muscæ*) appear. The fox (*Canis Vulpes*) smells rank. The turkey-cock (*Melægris Gallo-Pávo*) struts and gobbles.

Fourth week: the yellowhammer (*Emberiza Citrinella*) and green wood-pecker (*Picus vridis*) sing; rooks, ravens (*Córv*), and house pigeons (*Columbæ*) build; the goldfinch (*Fringilla Carduelis*) sings. Field-crickets (*Scarabæi*) open their holes; and the common flea (*Pulex irritans*) appears.

2. Calendar of Vegetable Nature round London.

In the first week: various species of the pine, larch, and fir tribe in full flower; the rosemary (*Rosmarinus officinalis*), the willow (*Salix*) and bay (*Laurus nobilis*) in blossom; various trees and shrubs beginning to open their buds.

Second week: the common honeysuckle (*Lonicera Periclymenum*), and some roses in leaf; *Crocus vernus*, and other sub-species, and some *Scilla* in flower. Pilewort (*Ficaria*), and creeping crowfoot (*Ranunculus repens*), *Hepatica*, and elder (*Sambucus nigra*), sometimes in leaf.

Third week: *Saxifraga oppositifolia*, *Draba verna*, *Daphne pontica*, and collina; and *Lonicera nigra*, in flower.

Fourth week: the peach, nectarine, apricot, *Cochorus japonicus*, *Pyrus japonica*, crown imperial, *Saxifraga crassifolia*, *Buxus sempervirens*, and other plants, in warm situations, in flower, or just advancing to that state.

3. Farm-yard. (2902.)

Wintering cattle should be liberally supplied with food from this time, till they can be wholly turned to grass: as straw and hay gets drier at this season, more should be given, and the supply of turnips, or other roots, rather increased than diminished. Where oil cake, brewers' grains, and similar articles can be obtained, they are valuable auxiliaries. Fattening cattle (6852.) and milch cows (6865.) require continued attention to food, cleanliness, and moderate exercise. Working horses must be kept in good condition; if they fall off now, they will not recover themselves for several months. Potatoes may now be cut into sets preparatory for next month.

4. Live Stock. (6216.)

Sheep now drop their lambs freely; and none pay better than such as are turnip fed at this time, and finished off in April, on forward pasture. As turnips begin to run to flower about this time, they are apt to prove more than usually laxative, and therefore the stock supplied with them should have an extra supply of hay.

5. Grass Lands. (5643.)

Meadows intended for mowing (5768.) should now be shut up, their surface having been freed from stones or other extraneous matters, the furrows or water gutters made completely effective, and, if the weather will permit, the surface bush-harrowed, and rolled. Meadows which have been flooded during winter will, in favourable situations, show a considerable crop of grass by the beginning of this month. Turn off the water a week or ten days, till the surface gets firm; then feed with ewes and lambs, giving a little hay in the evening. Calves may also be turned on these meadows, but nothing heavier. The best mode is to hurdle off the grass in strips, in the manner of eating turnips or clover in the places of their growth. Moles (7631.) and worms (7704.) are best destroyed at this season.

6. Arable Lands. (4925.)

There are few hardy seeds, whether of agriculture or gardening, that may not be committed to the soil during this month. Spring wheat of the common kind (5004.) may still be sown; but if possible, not later than the middle of the month; oats (5120.), rye (5069.), barley (5080.), canary corn (5169.), buckwheat (6111.), beans (5222.), peas (5121.), tares (5257.), &c.

Clover and rye grass (5521.) may now be sown among young wheats after naked fallows, or among spring corn in lands in good heart and fine tilth.

Field beet (5482.), carrots (5443.), parsneps (5471.), and Swedish turnips should be sown the last fortnight of the month, provided the land is dry enough to be sufficiently cleaned, and pulverised to the depth of at least a foot. It more frequently happens that this cannot be got done till the beginning of April, and hence this class of seeds is seldom got in before the middle of that month. The carrots should be first sown, and the Swedish turnip will bear to be the latest. Lands intended for potatoes, carriages, turnips, transplanted Swedish turnip, and other plants of the *Brassica* kind should be brought forward by such ploughings, cross ploughings, and workings with the grubber, as their nature and state may require. It is one great advantage of the common white turnip, that it admits of two months more time for preparing the soil than other root or *Brassica* crops. Summer or wheat fallows require at least one furrow in course of the month.

7. Fences (2960.) Roads (3523.), and Drains. (4213.)

Thorns and other hedge plants may be put in, but the earlier in the month the business is completed the better. This is an excellent season for making or repairing roads (3727.), drains, ponds, embankments, &c., the ground being still moist, and the days sufficiently long to admit of a man's labouring ten hours, or from six to six. In January, the ground is often too wet, or frozen, or covered with snow, and the days too short for advantageous day labour. In July and August the ground is too dry and hard for spade work, and day labour high on account of the proximity of hay-time and harvest.

8. Orchards (4079.) and Hop Grounds. (5997.)

Finish pruning fruit-trees (4111.), and also digging round their stems, if that is practised. (4119.) Where young orchards are grazed, see that the guards or fences to the single trees are in repair.

Form plantations of hops (5997.), and open up and dress the hills of established plants, returning the mould to their roots. (6025.)

9. Wood-lands and Plantations. (3906.)

In the tree nursery, finish sowing acorns, keys, nuts, mast, berries, stones. Sow also the lighter trees, as poplar seed (where it can be got), willow, birch, alder, elm, &c. Transplant from the seed bed, or from narrow to broader intervals, and attend to other parts of the usual routine culture.

New plantations may still be planted, endeavouring if possible to finish putting in deciduous trees with the month; using the puddle in dry weather (3940.), and fixing by water. (3952.) Where large trees are introduced, the latter generally require to be staked.

Evergreens of the harder kinds, as the Scotch pine, spruce fir, &c. may be transplanted in the last week of the month, but not safely before. They are often put in during any of the winter months, but the result shows the impropriety of the practice.

Fill up blanks (3983.) in young plantations and hedges, and fell timber, cut over coppice woods, and thin out young woods as in last month. When plantations are to be raised from seed where they are to remain for timber (3926.), this is the month for most seed, but April is better for the pine and fir tribe. Sow the others in the second or third week of the month; and if resinous trees are to be mixed, a sprinkling of their seeds can be sown over the others in April.

APRIL.

Weather at	Average of the Thermometer.	Greatest Variation from the Average.	Average of the Barometer.	Quantity of Rain.	REMARKS.
London -	49 9	3	29 77	1.460 inch.	The weather of this month is distinguished by the rapidity of its changes. It is generally stormy, interspersed with gleams of sunshine, hail, snow, some frost, and occasionally violent storms of wind. It is a month of the utmost activity to the cultivator of arable land, who during its course finishes the sowing of spring corns and grasses, and begins that of roots and leaves.
Edinburgh	46 3	- -	29 875	2.414	
Dublin -	51 125	- -	32 909	2.561	

1. Calendar of Animated Nature round London.

In the first week: the viper (*Cócluber bérus*) and woodlouse (*Oniscus Asellus*) appear; the misseltoe thrush (*Turdus viscivorus*) pairs; frogs (*Ranæ*) croak and spawn, and moths (*Phalænæ*) appear.

Second week: the stone curlew (*Charadrius Edicnemus*) clamours; young frogs (*Rana temporaria*) appear. The pheasant (*Phasianus*) crows, the trout (*Salmo Trutta*) rises, and spiders (*Aranéæ*) abound.

Third week: the crested wren (*Motacilla Régulus*) sings; the blackbird (*Turdus Mérula*), raven (*Córvus Corax*), pigeon (*Columba domestica*), hen (*Phasianus Gallus*), and duck (*Anas boscha*) sit; various insects appear; and the feldfare (*Turdus pilaris*) is still here.

Fourth week: the swallow (*Hirundo rustica*) returns; the nightingale (*Motacilla Luscina*) sings; the bittern (*Ardea rotellaria*) makes a noise; the house martin (*Hirundo úrbica*) appears; the blackcap (*Motacilla Atricapilla*) whistles; and the common snake (*Cócluber Natrix*) appears.

2. Calendar of Vegetable Nature round London.

In the first week: the daffodil (*Narcissus Pseudo-narcissus*), the garden hyacinth (*Hyacinthus orientalis*), the wallflower (*Cheiranthus Cheiri*), the cowslip (*Prímula officinalis*), the periwinkle (*Vinca*), sloe (*Prúnus spinosa*), and various other herbs and trees in flower.

Second week: the ground-ivy (*Glechóma hederacea*), gentiánella (*Gentiána acaulis*), *Pulmonaria virgínica*, the auricula, *Iberis sempervirens*, *Omphalodes verna*, and most of the common fruit-trees and fruit-shrubs in flower.

Third week: some *Robíniæ*, *Andrómedæ*, *Kálmia*, and other American shrubs; *Dáphne Lauréola*, *Ulmus campestris*, *Chryso-spléndium oppositifólium*, *Mercurialis perennis*, and other plants in flower.

Fourth week: the beech (*Fágus*) and elm (*Ulmus*) in flower; ivy-berries drop from the racemes; the larch in leaf, and the tulip and some white narcissi and fritillaries in flower.

3. Farm-yard. (2902.)

This month will in most situations terminate the wintering of cattle in the straw-yard. Straw is now very dry, therefore turnips, or other green food or roots, should be added in proportion.

Horses should be kept in high order, on account of the hard work and extra exertion often required of them during this month. If there are carrots or potatoes to steam for them once a day, that will greatly aid hay and corn; if not, steam a part of the hay.

The accidental supplies of food for store pigs and poultry are less abundant during this month, because less time can be spared for threshing. There are fewer wintering cattle, and the yards are generally now cleaned out for the field dung-hills.

4. Live Stock. (6216.)

The end of this month is a good time for mares to foal (6629.), and they should have the horse accordingly. (6631.) Attend at the proper periods, first to moderate working, and then to entire ease before foaling time. (6641.)

Cows must still be well fed with roots or steamed food, within doors, letting them taste the grass occasionally towards the end of the month. (6863.)

Sheep and lambs generally require a good deal of artificial food during the first half of this month. When the turnips are expended, clover hay, grains of barley which have been malted, rape cake, or linseed cake, are the next resources. (6094.) About the end of the month they may be turned on the pastures, and then it is that mutton generally drops in price:—a hint to the farmer to sell all he can in the early part of April.

Where there are water-meadows, the sheep and lambs will have been fattening on these during the whole of the month, — an immense advantage to a farmer.

Poultry of most kinds have now hatched their broods, and require looking after, to see they do not injure one another, nor are attacked by stronger enemies.

5. Grass Lands. (5643.)

See that the fences are kept up, and the gates regularly shut and fastened; as cattle newly let out are very apt to wander, and more ready to break through fences than when the herbage is more abundant.

Water-meadows (4371.) are generally shut up for hay about the end of the month, the ewes and lambs being then turned on young artificial grasses, or common provincial pastures, in a sufficiently for vord state.

Mowing-meadows of the common kind (5768.), and clovers, and mixed grasses for hay, should be hand-picked, bush-harrowed, and rolled, early in the month, and then shut up for the scythe.

6. Arable Lands. (4925.)

Finish sowing all the spring corns (5080.), peas, tares, lucerne (5574.), sainfoin, and all other herbage, plants, and grasses. (5645.)

Summer wheat (5004.) may be sown during the whole of the month, also barley in late situations (5080.), peas for late podding, and under peculiar circumstances, tares for cutting green in October and November.

Manufactorial plants, as woad, madder, flax, hemp, mustard, &c.; oil plants, as rape, poppy, and such plants as are grown for medicinal purposes or peculiar uses in domestic economy, as rhubarb, liquorice, buck or beech wheat, cress, &c. may all be sown or planted from the middle of last to the middle of this month. The first week in April will, in the greater number of seasons, soils, and situations, suit the most of them.

Carrot (5445.), field beet (5482.), parsnep (5417.), and Swedish turnip (5409.), if not sown the last week of March, should be finished during the first ten days of April. A bed of Swedish

turnips should be sown in the garden for transplanting in the field by the end of the month, or the first week in May.

The last fortnight of the month is the best season for planting potatoes (5316.); in the earliest situations this is soon enough for a full crop; in the latest, the middle of May will answer better. For very early crops for the supply of summer markets, dry rich sheltered fields may be planted in March. In the moors of Scotland they often plant in June, and still have a crop; there the potato is alike obnoxious to late spring and early autumnal frost.

7. Fences (2960.), Roads (3523.), and Drains. (4213.)

All these should have been put in order before, so as to leave the hedger of the farm (7714.), and the labourer of all work (7711.), time to assist in getting in planted crops, as potatoes, cabbages, &c. in the fields, cropping the garden, mowing, or otherwise dressing the orchard, shrubbery, lawn, or such ornamental or enjoyment ground as the farmer indulges in round his house.

8. Orchards (4079.) and Hop-grounds. (5997.)

In some cases fruit-trees may be so over-run with insects towards the end of the month as to make it worth while to burn wet straw under them; but this rarely happens before the middle of May, and even then farm orchards may almost always be left to the birds and vigour of the trees. Hops are generally poled in this month, and the ground between the hills afterwards stirred with the cultivator or nidget as it is called in Kent. (6026.)

9. Wood-lands and Plantations. (3906.)

All planting and pruning of deciduous trees should be finished the first week of the month. Afterwards the planting and pruning of evergreens may commence; first the common pine and fir, and afterwards the holly, yew, and other forest evergreens. (5937.) If these can be watered, and staked, so much the better. Barking oaks may in some warm situations be felled the last week of the month, but May is the more general time. (4050.)

MAY.

Weather at	Average of the Thermometer.	Greatest Variation from the Average.	Average of the Barometer.	Quantity of Rain.	REMARKS.
London -	56 61	2 5	30 02	0.794 inch.	Vegetation now goes on with great vigour, though there are often very cold and even frosty nights, which materially injure the blossoms of fruit-trees, and sometimes the young shoots of the hop and potato. Man, in common with other animals, being now full of life and vigour, the consummation of animal desire is frequent; but marriage is better deferred till September, when the offspring will be born in the May or June following, a season of the year when the poor man can better support the expenses of an accouchement than in the cold month respondent to marriages in May.
Edinburgh	50 4	- -	29 585	1.915	
Dublin .	52 193	- -	30 061	1.812	

1. Calendar of Animated Nature round London.

In the first week: the titlark (*Alauda pratensis*) sings, the cuckoo (*Cuculus canorus*) is heard; the gudgeon (*Cyprinus Góbio*) spawns; the redstart (*Motacilla Phœnicurus*), swift (*Hirundo A'pus*), whitethroat (*Motacilla Sylvia*), and sting-fly (*Cônops calcitrans*) appear.

Second week: the turtle-dove (*Colúmba Túrur*) coos; the red ant (*Formica rúbra*), the laughing wren (*Motacilla Currúca*), the common flesh-fly (*Múscu vomitória*), the lady-cow (*Coccinella bipunctata*), grasshopper lark (*Alauda Locústæ vocis*), and willow-wren (*Motacilla Salicaria*) appear.

Third week: the blue flesh-fly (*Múscu vomitória*) appears; black snails (*Hélix nigra*) abound, and the large bat appears.

Fourth week: the great white-cabbage butterfly (*Papilio brassicæ*) and dragon fly (*Libellula 4-maculata*) appear; the glow-worm shines, and the fern-owl, or goat-sucker (*Caprimulgus europæus*), returns.

2. Calendar of Vegetable Nature round London.

In the first week: *Géum urbánum*, *Artemisia campéstris*; lily of the valley (*Convallaria majalis*), water-violet (*Hottonia palustris*), tulip-tree (*Liriodendron tulipifera*), and numerous other plants in flower.

Second week: the oak, ash, sweet chestnut (*Castanea véscu*), hawthorn (*Mésphilus Oxyacantha*), the common maple (*A'cer campéstre*), horse-chestnut (*Æsculus Hippocástanum*), barberry (*Berberis vulgáris*), and the *A'júga réptans* in flower.

Third week: the water scorpion-grass, or forget-me-not (*Myosótis scorpioides*), lime-tree (*Tilia*), milk-wort (*Polýgala vulgáris*), nightshade (*A'tropa Belladónna*), and various American shrubs in flower, and rye (*Secale lybérnum*) in ear.

Fourth week: oaks, ashes, and beeches now generally in leaf, and the mulberry (*Morus nigra*) beginning to open its buds. The cinnamon rose and some other hardy roses in flower; and also the bramble (*Rubus fruticosus*), moneywort (*Lysimachia Nummularia*), columbine (*Aquilégia vulgáris*), and various other trees and shrubs in blossom.

3. Farm-yard. (2902.)

Feeding and wintering on straw and roots generally ends, and soiling (5542.) or pasturage (5562.) commences, in the first fortnight. Where high-flavoured milk and butter are preferred to quantity, then pasturage on dry-bottomed uplands is to be preferred; but where quantity and richness is the object, soiling with clover and tares, and two or three hours' pasturage per day, for the sake of exercise, is the preferable system. Even on farms where there is nothing to mow but old meadow, soiling with that will be found more economical than pasturing it. A field of meadow in good heart, mown and eaten green, will, at a rough estimate, produce treble the quantity of milk it would have done if pastured, and four times as much as it would do in the form of dry hay.

The yards and pits are generally cleared of dung, urine, &c. at this season; and if no soiling goes on, they should be kept

clean during the summer, excepting what room is required for the dung of the few stock which are there constantly, as pigs and poultry, or occasionally, as horses while harnessing, &c.

4. Live Stock. (6216.)

In turning cattle to grass, consider the different systems of pasturing (5816.); adopt what suits your circumstances, and pursue it regularly. See that water is not wanting to each field (4463.); nor shade, rubbing posts, and shelter. (5835.)

Lean stock are generally dear during this month, from the number of persons who buy in and feed off on grass. When cattle or sheep are very numerous, they are found to feed better, and do less injury to the grass, in small herds or flocks, than in large ones.

Mares may have the horse during the first week, but not later considering the season of parturition. (6637.)

5. Grass Lands. (5643.)

As most grasses send up their flower-stalks during this month, it is of importance so to stock pastures, as to eat these down. This is only to be accomplished in recently sown down lands by overstocking, and not then completely if rye grass prevails. When grass lands are to be mown, the best crop of hay will be obtained by not pasturing after the middle of April. Some may think that where cattle and sheep are fed till May or June, the stalks left will come in as hay; but as such fields cannot be mown till the end of July, the stalks have long before shed their seed and become dry, and so shrivelled as to be unfit for food.

Where paring and burning are wanted, this is a favourable season. (3209.)

Water-meadows, having been eaten down in April, are generally watered for the first three or four weeks of this month, to bring forward the crop of hay. (4429.)

6. Arable Lands. (4925.)

Summer wheat (5004.) and grass seeds (5875.) may still be sown, but not profitably after the first week or ten days. Swedish turnip (5409.), marygold, and yellow turnip may be profitably sown, and also early crops of common white turnip where the soil is clean and duly prepared. (5394.)

The preparation of turnip fallows is the great business of this month, and next the stirring of naked fallows (4944.), and the culture, by horse and hand hoes, of corns and pulse in drills. In late situations potatoes may be planted during the whole month (5316.); and hemp and flax sown during the first fortnight. (5880. and 5922.) Tares for successional supply. (5257.)

7. Fences (2960.), Roads (3523.), and Drains. (4213.)

Clean young hedge-rows. (2982.) Drains may now be advantageously designed, as the springs show themselves more conspicuously during winter. The rest in this department is mere routine.

8. *Orchards* (4079.) and *Hop-grounds*. (5997.)

Grafted trees should be looked over occasionally, and any that the clay has dropped from re-covered. Remove suckers and superfluous side shoots.

Stir and clean the *hop-plantations*; place the poles, tie the vines where necessary; and towards the end of the month, when the number of shoots wanted have taken the lead; cover

the stool or centre of the plant with a small hill of soil, to prevent it from sending up more shoots.

9. *Wood-lands and Plantations*. (3906.)

Continue to bark *oak trees*, and also the larch, and such others as are adapted for the farmer (4044.), but finish, if possible, by the middle of the month. Keep newly planted large trees properly staked, and all kinds of cultivated ground clear of weeds.

JUNE.

Weather at	Average of the Thermometer.	Greatest Variation from the Average.	Average of the Barometer.	Quantity of Rain.	REMARKS.
London -	63 22	2	29 93	0.332 inch.	The weather is sometimes cold at the beginning, but is generally agreeable and steady towards the middle of the month. By observing the columns indicating the greatest variation of the thermometer in each month, it will be seen that it varies, in London, only two degrees in June, which is less than in any of the preceding months. In July and August the variation is the same; but in March and October it is twice as much.
Edinburgh	57 2	- -	29 666	1.935	
Dublin -	58 76	- -	30 06	0.860	

1. *Calendar of Animated Nature round London*.

In the first week: the sedge-sparrow (*Passer arundinacea*), the fly-catcher (*Muscicapa atricapilla*), the wasp (*Vespa vulgaris*), and several species of the bee and butterfly appear.

Second week: the burnet moth (*Sphinx filipendulae*), and forest-fly (*Hippoboscæ equina*) appear; bees swarm.

Third week: several flies, butterflies, moths, beetles, and other insects appear.

Fourth week: insects abound; and singing-birds begin to retire to the woods, and leave off singing.

2. *Calendar of Vegetable Nature round London*.

In the first week: water-lilies (*Nymphaea et Nuphar*) flower; also *Iris Pseud-æcorus*, *Anthemis Cótula*, *Polygonum Persicaria*, *Málva rotundifolia*, and numerous other plants.

Second week: the vine, raspberry, and elder in full flower; also various Scotch roses (*Rosa spinosissima*), broom (*Spartium*), nettle (*Urtica*), and wheat in the ear.

Third week: the *O'rechis*, *Epilobium*, *Iris Xiphium* and *xiphoides*, the hardy *Ixia* and *Gladioli*, and a great variety of garden and field plants in flower; also the wheat and many of the pasture grasses.

Fourth week: some black and red currants ripe, strawberries in abundance; young shoots of trees and shrubs have nearly attained their length. Oats and barley in flower; blue-bottle, scabious (*Centauræa Cyanus*), and numerous others in bloom.

3. *Farm-yard*. (2902.)

Soiling is the principal operation now going forward (5542.), and requires the utmost attention to the cleanliness of the animals, whether fattening cattle, feeding milch cows, or horses.

4. *Live Stock*. (6216.)

Wash and shear sheep (7201.); examine flocks individually as to the fly (7175.); see to shade for every description of stock when the weather is hot. Bees swarm during this and next month.

5. *Grass Lands*. (5648.)

Hay-making is now a principal business (5544. and 5792.) Any tussocks or flower-stalks (bents) which appear, notwith-

standing the close feeding of April and May, should now be mown (5772.); thistles and similar weeds cut out close by the root (6202.); pare and burn as in May (3209.); clean out ponds, water-courses, wells, &c. See that clovers, tares, or other soiling crops are mown close to the soil.

6. *Arable Lands*. (4925.)

Great part of the turnip process goes on during the three first weeks of this month and the latter half of May. (5373.) Dung fallows and otherwise bring them forward (4568.), draining (4213.), levelling, altering ridges, &c. as the case may require; weed broad-cast crops, and stir the soil between such as are in rows. Warping, where it can be practised, may now be commenced (4450.); thin out the first sown turnips. (5406.)

7. *Fences* (2960.), *Roads* (3523.), and *Drains*. (4213.)

Weed hedges, but avoid clipping them, which only creates a close surface of feeble shoots, that in the end becomes so thick as to exclude light and air from the central stems, and occasions their languishing and death. (2985.)

Dig and otherwise prepare materials for roads (3635.) and drains. (4284.)

8. *Orchards* (4079.) and *Hop-grounds*. (5997.)

Insects, or other effects of what are called blights, can seldom be destroyed on so large a scale as that of the farm-orchard or hop-garden. Burning weeds or wet straw, litter, &c. will do something; and on a small scale, washing with lime-water, soap-suds, tobacco-water, or a mixture of these, will prove effectual. (6056.) Those who tie the binds or vine of the hop to the poles, instead of leaving them to nature, have generally completed the operation by the middle of the month. In some early spots the superfluous shoots are cut off about the end of the month.

9. *Wood-lands and Plantations*. (3906.)

The woodman is now chiefly employed in trussing up the branches of barked trees, and otherwise disposing of what is unfit for timber purposes. (4049.) Old copses or stools of trees, woods, or hedges, may now be advantageously stocked up, stacked, and when dry, charred for fuel. (4068.)

JULY.

Weather at	Average of the Thermometer.	Greatest Variation from the Average.	Average of the Barometer.	Quantity of Rain.	REMARKS.
London -	66 3	2	29 89	2.194 inch.	This was called <i>hay month</i> by the Saxons; and though hay-making near London is generally finished in June, yet in places where manure is less abundant, it is chiefly made in this month. The farmer's prospects as to crop may now be determined as to almost every article cultivated.
Edinburgh	60 6	- -	29 445	2.546	
Dublin -	61 13	- -	29 929	2.614	

1. *Calendar of Animated Nature round London*.

In the first week: the cuckoo (*Cuculus canorus*) leaves off singing; the stone-curler (*Charadrius Edicnemus*) whistles occasionally late at night, and the golden-crested wren (*Motacilla Regulus*) now and then chirps.

Second week: the quail (*Tetrao ferrugineus*) calls; the cuckoo-spit, or frog-hopper (*Cicada spumaria*), abounds.

Third week: young frogs migrate. Hens moult.

Fourth week: the great horse-fly (*Tabanus bovinus*) appears; and partridges fly.

2. *Calendar of Vegetable Nature round London*.

In the first week: enchanter's nightshade (*Circæa lutetiana*) and lavender (*Lavandula spica*) in flower, and pinks and carnations in full bloom.

Second week: the fallen star (*Tremella Nóstoc*) appears; also puff-balls (*Lycopérdon Brvista*), and sometimes the common mushroom (*Agaricus campestris*).

Third week: raspberries and gooseberries ripe, potatoes in flower, asparagus in berry, the liliuns in perfection.

Fourth week: the truffle (*Tuber cibarium*) now hunted or dug up in commons and forests; nightshade (*Solanum nigrum*), devil's bit (*Scabiosa succisa*), burnet saxifrage (*Pimpinella Saxifraga*), and a great number of plants in flower.

3. *Farm-yard*. (2902.)

As in June; between hay and corn harvest is generally a very good time for the farmer to make a tour to observe more extensively the practices of his own district, and to witness those of other districts.

4, 5. *Live Stock* (6216.) and *Grass Lands*. (5648.)

Lambs are now weaned (7161.) when not fattened off; at first they require the richest keep. As green food will now be abundant, every animal about a farm that can live and thrive or answer its end by the soiling system, should be so treated. The weather being hot, cattle or sheep in fields must be frequently looked to, as to shade, water, and abundant keep. Suffering from thirst, or a want of food, they are very apt to break through fences, which at this season is more than usually injurious, on account of the state of the corn crops.

6. *Arable Lands*. (4925.)

Attend to weeding, hoeing, and otherwise moving the soil between rowed crops, more especially potatoes and turnips. Towards the end of the month, the first-sown white turnips will be in a state to thin out; and a farther thinning may be advantageously given to field beet, carrots, &c., at this season. Where peas are sown for podding, they will now be in abundance for gathering; in warm situations sooner. Buck-wheat may now be sown for autumnal food for game. (6111.)

7. *Fences* (2960.), *Roads* (3523.), and *Drains*. (4213.)

8. *Orchards* (4079.) and *Hop-grounds*. (5997.)

Cherries, raspberries, gooseberries, &c., where grown as field-crops, are now in gathering, and towards the end of the month, fallen apples and plums for tarts. Hop-grounds are looked over, and the superfluous vine pruned off, &c. In Kent

and other places these prunings are often a requisite of the pruner, who lays them aside as fodder for cows.

9. *Wood-lands and Plantations.* (3906.)

As in June; and prune the gean, which at other seasons is apt to bleed. (3995.) This season answers perfectly for pruning

all sorts of trees; and if their leaves and spray were an object for fodder, as in Sweden and Italy, no doubt it would be preferred. (3994. and 3996.) Wounds in trees do not now bleed as they sometimes do in spring and autumn; and they heal, and are in part covered over with bark, before the approach of winter. (3993.)

AUGUST.

Weather at	Average of the Thermometer.	Greatest Variation from the Average.	Average of the Barometer.	Quantity of Rain.	REMARKS.
London -	65 85	2	30 06	0·824 inch.	This is the barn or <i>harvest month</i> of the Saxons; and, as every body knows, the busiest month of the agriculturist. It is, in consequence, the most profitable season for the labourer and his family, who are generally in full employ, and at an increase of wages, or perquisites, for four or six weeks at this season.
Edinburgh	60 6	- -	29 828	1·996	
Dublin -	62 82	- -	30 172	5·858	

1. *Calendar of Animated Nature round London.*

In the first week: flying ants (*Formica*) appear; bees kill their drones; and the swallow-tailed butterfly (*Papilio Machaon*) appears.

Second week: young martins (*Hirundo urbica*) and swallows (*Hirundo rustica*, begin to congregate, and swifts (*Hirundo Apus*) to depart; the whame, or burrel-fly (*Æstrus bœvis*), lays eggs on horses.

Third week: the black-eyed marble butterfly (*Papilio Semele*) appears. Various birds re-assume their spring notes.

Fourth week: the nuthatch (*Sitta europæa*) chatters, the stone-curlew (*Charadrius Edicnemus*) whistles at night, the goat-sucker (*Caprimulgus europæus*) and young owls (*Strix U'lula*) make a noise in the evening; robin-redbreast (*Motacilla Rubicola*) sings; and rooks roost on their nest-trees.

2. *Calendar of Vegetable Nature round London.*

In the first week: melilot (*Trifolium officinale*), rue (*Ruta graveolens*), yellow succory (*Picris hieracioides*), burdock (*Arc-tium Lappa*) in flower; the bread-corns ripe.

Second week: wild clary (*Sálvia Verbenæca*), meadow-rue (*Thalictrum flavum*), ploughman's spikenard (*Conyza squar-rôsa*), and various other natives in flower.

Third week: the mallow (*Málva Lavatêra*), hollyhock (*Alcêa rôsea*), and lobelias, among the garden-flowers; and the poly-gonums and potamogetons among the wild plants now in blossom.

Fourth week: the autumnal crocus (*Cólchicum autumnale*), *Aster Solidago*, *Senecio paludôsus*, teasel (*Dipsacus fullônum*), and various other plants in flower. The earlier varieties of all the hardy kernel fruits ripe.

3. *Farm-yard.* (2902.)

The *rick-yard* should now be attended to (2906.); stack-stands repaired or put in order: bottoming of faggots, and straw or rape haulm got together; thatch in readiness, and ropes made. (3184.)

At any spare period the teams may be employed carting out the summer-made dung to the wheat fallows, or to form field dunghills for spring crops, &c.

4. *Live Stock.* (6216.)

Select the stock of lambs to be kept as breeders. (7170.) Swine commonly bring their second litter of pigs in this month; which, owing to the dropping corn, is generally one of abundant keep, both for them and poultry. Farmers in some places look to the stubbles as a source of good food for their cows, as

others do to the fallows for keep for their sheep. Where either is the case, the culture must be of a very inferior description.

5. *Grass Lands.* (5643.)

Where *meadows* are manured, that operation generally goes on after the hay is removed, or during winter; the surface in the former case being hard with drought, and in the latter by frost. After grass should in general be shut up and reserved for later keep, and in some cases as a winter resource. Keep down weeds, tussocks, ant-hills, &c. Turn the water on meadow-lands as soon as the hay is removed, and let it remain till a third crop is in forwardness. (4387.)

6. *Arable Lands.* (4925.)

Weed and stir among green crops, earth up potatoes (5536.), but by no means turnips, unless the soil is very dry indeed, as that operation only prevents them from attaining a full size. Reaping commences in all the southern districts in the first week of this month, and in some by the middle of July. When the operation is executed by day-work, the most unremitting inspection of the master is necessary; and even when the greatly preferable mode of reaping by the acre is adopted, he should be continually in motion from one party to another, to see that the operation is performed low and clean.

Naked fallows in late situations receive the seed furrow during this month, excepting in cases where the seed is ploughed in, an operation generally deferred to the middle of September. Sow cabbage-seeds (4497.) for plants to put out in April next. Sow turnips after early peas which have been podded (5209.), or early cut wheat, tares, cabbages, &c., or after hemp and flax, which are generally pulled by the middle of this month. (5880. and 5922.) Grass seeds sown alone at this season (5692.) will generally succeed better than at any other; they germinate as well in spring; but the heats of July often burn up the tender plants.

7. *Fences* (2960.), *Roads* (3523.), and *Drains.* (4213.)

As in the two preceding months.

8. *Orchards* (4099.) and *Hop-grounds.* (5997.)

Apples and plums of some sorts are now ripe. Grafts may in general be untied. Budding performed, and pruning, if desirable, as observed last month under woods and plantations.

9. *Wood-lands and Plantations.* (3906.)

See last month.

SEPTEMBER.

Weather at	Average of the Thermometer.	Greatest Variation from the Average.	Average of the Barometer.	Quantity of Rain.	REMARKS.
London -	59 63	3 5	30 09	0·482 inch.	The temperature begins now to decline and to vary; the nights begins to lengthen, and heavy dews and diminished transpiration and evaporation promote the growth of grass, herbage, plants, and especially turnips. This is still a busy month with the agriculturists; in the warmest situations he is finishing harvest-work, and in the latest commencing it. Animals of most sorts are now fat; fruits are ripe; honey abundant; and most products of the earth in perfection and plenty.
Edinburgh	54 3	- -	29 739	3·470	
Dublin -	59 75	- -	30 239	3·021	

1. *Calendar of Animated Nature round London.*

In the first week: young broods of goldfinches (*Fringilla Carduelis*) appear. The linnet (*Fringilla Linôta*) congregates. The bull (*Bôs Taurus*) makes his shrill autumnal noise; and swallows (*Hirundo rustica*) sing.

Second week: common owls (*Strix flâmmea*) hoot. The saffron butterfly (*Papilio Hycle*) and willow red under-wing moth (*Phalœna picta*) appear. Herrings (*Clupea Haréngus*) are now cheap.

Third week: the ring ouzle (*Túrdus torquatus*) appears. The fly-catcher (*Muscicapa Atricapilla*) withdraws.

Fourth week: the stare (*Stúrnus vulgaris*) congregates. The wood-lark (*Alauda arbôrea*) sings. The woodcock (*Scólopax rusticola*) and fieldfare (*Túrdus pilaris*) appear; and the swallow (*Hirundo rustica*) departs.

2. *Calendar of Vegetable Nature round London.*

In the first week: some fungi and *Ballôta álba* appear, traveller's joy (*Clematis álba*) and *Parnássia palústris* in flower.

Second week: catkins of the hazel and birch formed; blossoms, and green, red, and black berries found on the bramble at the same time. Leaves of the sycamore, birch, lime, mountain-ash and elm, begin to change colour.

Third week: the ivy (*Hêdera Hêlix*), laurel (*Prúnus Lauro-côrasus*) and furze (*Ulex europæa*) in flower.

Fourth week: hips, haws, and nuts ripe. Leaves of plane-tree (*Plátanus*) tawny; of the hazel, yellow; of the oak, yellowish-green; of the sycamore, dirty brown; of the maple, pale yellow; of the ash, fine lemon; of the elm, orange; of the hawthorn, tawny yellow; of the cherry, red; of the hornbeam, bright yellow; of the willow, hoary.

3. *Farm-yard.* (2902.)

The *rick-yard* is now the chief scene of operations, in getting earlier crops thatched (3185.) and later ones stacked. (3276.) In all operations in this department attend, as far as circumstances will permit, to neatness. In the case of a proprietor or amateur, neatness, order, and high keeping are essential in every department.

4. *Live Stock.* (6216.)

There is generally abundance of fat cattle and sheep in the market during this and next month. Lean stock, especially crones and widders, are now brought in, and wintered or fed off on turnips. Wintering cattle (6855.) also about the end of the month. Poultry and pigs are now fat, and honey may be taken from bee-hives.

5. *Grass Lands.* (5643.)

As in August. Newly sown grass lands should now be sparingly fed, in order to strengthen the plants for the winter.

5. *Arable Lands.* (4925.)

This is the chief season for sowing winter wheat, whether on naked fallows or after clover, tares, rape, or early crops of peas and beans. Potatoes are generally not taken up till the end of the month, in which case the sowing after that crop is later. (5015.) Sow tares to stand the winter (5257.), and grass seed, for permanent pasture; or a hay crop next season will succeed on good soils, if sown before the middle of the month. (5533.)

7. *Fences* (2960.), *Roads* (3523.), and *Drains.* (4213.)

Routine operations of mending, &c. as before.

8. *Orchards* (4079.) and *Hop-grounds.* (5997.)

Gather *fruits* for immediate sale, the keeping sorts not being yet ripe. (4085.) Walnuts for pickling not later than the first week. (4102.)

Hop-picking and drying, in the districts where this plant is much cultivated, is the great business of the month. (6036.)

9. *Wood-lands and Plantations.* (3906.)

Routine operations as in the two or three preceding months. Plant evergreens during the three last weeks, and deciduous trees the last ten days. (3937.)

OCTOBER.

Weather at	Average of the Thermometer.	Greatest Variation from the Average.	Average of the Barometer.	Quantity of Rain.	REMARKS.
London -	52 81	4	29 69	2.027 inch.	The weather of this month is very uncertain. Before those rains, snows, or frosts which constitute the practical commencement of winter, there is generally two or three weeks of settled weather; sometimes these weeks are in October, sometimes partly in November. These weeks afford a last resource for bringing forward neglected operations.
Edinburgh	49 7	-	29 539	3.334	
Dublin -	51	-	29 76	2.798	

1. *Calendar of Animated Nature round London.*

In the first week: the red-wing (*Turdus iliacus*) arrives. Snakes and vipers bury themselves.

Second week: hooded crows (*Córvus Córnix*) and wood-pigeons (*Colúmba Palúmbus*) arrive; hen-chaffinches (*Fringilla cœlebs*) congregate, and prepare for migration, leaving their males in this country.

Third week: the snipe (*Scólopax Gallinàgo*) appears in the meadows. Wild-geese (*Anas sylvéstris*) leave the fens, and go to the rye-lands.

Fourth week: the tortoise (*Testudo græca*) begins to bury himself in the ground; and rooks visit their nest-trees. Some larks (*Alaudæ*) sing, and the woodcock (*Scólopax rustícola*) returns. Spiders' webs abound.

2. *Calendar of Vegetable Nature round London.*

In the first week: strawberry-tree (*Arbutus U'nedo*), holly (*Ilex Aquifolium*), China hollyhock (*Alcæa chinénsis*), and China aster (*Aster chinénsis*), in bloom.

Second week: catkins of some species of *Salix* formed; leaves of the asp almost all off; of the Spanish chestnut, yellow; of the sugar-maple (*Acer saccharinum*) scarlet; of the common birch, yellow and gold; and of the weeping-birch, gold and bright-red coloured.

Third week: *Clématis calycina* in flower. Some horse-chestnuts and acacias quite denuded of leaves.

Fourth week: various plants, especially annuals, continue in flower. Leaves of marsh-elder (*Sambucus E'bulus*), of a fine pink; of stag's-horn sumach, of a purplish-red; of the American oaks, of fine shades of yellow, orange, red, and purple.

3. *Farm-yard.* (2902.)

This is the season of rural plenty, affording an opportunity, both to men and animals, for laying in a large stock of health, to enable them to support the severity of the coming winter. Operatives should now buy in their winter stores of potatoes, fuel, &c. and ridge up their garden ground, not under crop, for the winter.

Corn crops being generally in the rick-yard by Michaelmas, and the root and herbage crops not taken being at or near maturity, the first of October is the most suitable season for a farmer to take stock and ascertain his annual profit or loss. Michaelmas being also the most general term of entry and removal, especially in the case of arable farms, is another reason why agricultural accounts are conveniently made up to this period. (4883.) Examine your household accounts, and if your expenses have exceeded your income, or even come up to it, look over the particulars with your wife or housekeeper, and see on which you can retrench. This is an essential process for all who would proceed in life with any thing like peace of mind, or the permanent respect of their neighbours. (4921.) Remember that very small indeed is the net income of a rent-paying agriculturist.

Michaelmas is also the general term for hiring farm-servants by the year; but the seldomer agricultural operatives are changed the better, unless in the case of senseless, indolent, or viciously inclined persons, who degenerate unless frequently removed.

4. *Live Stock.* (6216.)

Cattle and sheep not sufficiently fattened on grass or herbage, whether by pasturage or soiling, should now be put on other food, to complete them for the butcher. Oil-cake, grains, turnips, carrots, or, in default of these, bruised corn may be used. The same observations may be applied to hogs, which are generally in good condition at this season. (7315.)

Hog porridge. A mixture of oatmeal and water, or any other meal and water, left till it becomes sour, as practised by the millers in the northern counties, will feed hogs rapidly; but milk and peas meal make the finest pork in the world.

The *teams* which have been soiled during summer, may now be put on hay, straw, and carrots, or other roots, by degrees. (6752.)

5. *Grass Lands.* (5643.)

Where these are manured, this is a good season for the operation (5782.); choose dry weather.

6. *Arable Lands.* (4925.)

Potatoes (5291.), carrots (5443.), field beet (5482.), parsneps (5471.), and Swedish turnips, may now be taken up and housed, and the ground sown with wheat. This grain (5001.), rye (5069.), barley (5080.) in some situations, and tares (5257.) may still be sown in the milder districts. Embrace every opportunity to give the first furrow to fallows (4944.), whether for green crops or otherwise. In general all lands that are to have two or more furrows before they are sown or planted, should be ploughed as soon as possible after harvest; but not so lands that are to be sown on one furrow, which are better ploughed in January and February. It is a great mistake to suppose that ploughing land in autumn destroys the eggs or larvæ of insects (7695.), or the seeds of weeds; on the contrary, it may often, by giving them a deeper covering, preserve them better from the winter's frost, or what is much more destructive, from being devoured by birds. There are few subjects less generally understood than the economy of nature in regard to the eggs of insects and worms. (Turn to 7644. and 7704.) See that water furrows and drains run freely, and that fences and gates are in repair.

7. *Fences* (2960.), *Roads* (3523.), and *Drains.* (4213.)

Hedges may now be advantageously planted (2978.), grown ones pruned (2983.), old ones plashed (2989.), and imperfect ones repaired. (2993.) The Northumberland practice as to hedges (7809.) well deserves the study of the more southern agriculturalist. Roads and drains may be made or repaired at this season, and in spring, with better effect than during the heat and drought of summer. Road materials now bind better, and land-springs show themselves more distinctly.

8. *Orchards* (4079.) and *Hop-grounds.* (5997.)

The *winter fruits* may now be gathered, and either spread in an airy loft or upper floor, there to remain till used, or sweated in heaps, to extract a part of their moisture, and then buried in dry sand, or packed in close boxes or casks, to be kept in a cool and dry cellar. (1834. and *Encyc. of Gardening*, 2d Edit. 2289.)

Fruits trees of every kind may now be planted (4105.) and pruned. (4111.)

Hop-picking is generally completed the first week of the month; and as soon afterwards as convenient, the vine and poles removed, and the latter stacked till next spring. (6047.) Young hop plantations may be formed (6005.), and the soil among established grounds manured and ploughed. (6019.)

9. *Wood-lands and Plantations.* (3906.)

Hedges and plantations of evergreen trees may be made during the first week of the month; and no period of the year is better for transplanting all kinds of hardy shrubs.

Timber and coppice may be felled, and in general every operation preparatory to planting, as well as the operation itself, may go forward.

NOVEMBER.

Weather at	Average of the Thermometer.	Greatest Variation from the Average.	Average of the Barometer.	Quantity of Rain.	REMARKS.
London -	44 44	4	29 68	2.527 inch.	This is the <i>windy month</i> of the Saxons; it is generally also cold and moist, and one of the most disagreeable for the labouring agriculturists; but he may console himself with the shortness of the day, and hail the approach of evening, when he may lay aside his wet dress and fortify his mind by converse with books, or enjoy the comforts of his fire-side, and the solace of his wife and children; reading to or otherwise instructing them, or mending his boots or shoes.
Edinburgh	41 1	-	29 638	4.514	
Dublin -	43	-	29 74	0.394	

1. *Calendar of Animated Nature round London.*
In the first week: the buck (*Cervus Capreolus*) grunts.
Second week: the golden plover (*Charadrius pluvialis*) appears.
Third week: snails (*Limax*) and slugs (*Helix*) bury themselves.
Fourth week: greenfinches (*Fringilla Montifringilla*) flock. The winter moth (*Geometra brumaria* *Sum.*) and the common flat-body moth (*Geometra applana* *Sum.*) appear in gardens about the end of the month.
2. *Calendar of Vegetable Nature round London.*
In the first week: a few plants in flower, by accident, chiefly annuals, according to the season.
Second week: the fungus *Helvella mitra* appears. *Laurus tinus* in flower.
Third week: *Chimonanthus fragrans* in flower.
Fourth week: some primroses show flowers at this season; and some plants, unnaturally in flower, still continue if the weather is temperate.
3. *Farm-yard.* (2902.)
Wintering cattle are now introduced to the straw-yards (2902.) or hammels (2831.), and others to stalls for feeding or fattening. Live stock in general ought to be kept in good condition at this season, otherwise they are apt to fall off towards spring. Threshing goes on at intervals to supply straw. (3198. and 2773.)
4. *Live Stock.* (6216.)
 See *Farm-yard*.

5. *Grass Lands.* (5643.)
 Manure in dry weather (5782.); turn the water on meadows adapted for irrigation (4387.); destroy ant-hills (5775.); drain by surface gutters, or other means, where that operation is requisite; clear out water furrows for the same purpose; admit cattle and horses only on the driest pastures; see that sheep have shelter, and especially Dorset ewes likely to lamb next month.
6. *Arable Lands.* (4925.)
 See that water furrows and drains run unobstructed; plough and cart out manure, as weather and other circumstances permit.
7. *Fences* (2960.), *Roads* (3523.), and *Drains.* (4213.)
 As in last month; and see that they are in effectual repair, and fairly used.
8. *Orchards* (4079.) and *Hop-grounds.* (5997.)
 Complete the operations of last month, where interrupted, deferred, or neglected.
9. *Wood-lands and Plantations.* (3906.)
 As in last month, excepting when the weather is unfavourable. Felling all kinds of timber and coppice not adapted for barking for the tanner, may now go on freely, (4044.) Willows for baskets may be cut over (4042.), and baskets, hampers, crates, and hurdles, made by the woodman and hedger.

DECEMBER.

Weather at	Average of the Thermometer.	Greatest Variation from the Average.	Average of the Barometer.	Quantity of Rain.	REMARKS.
London -	41 4	3	29 64	1.124 inch.	<i>Winter month, Sax.</i> Cold but dry. The agricultural operations are chiefly of the laborious kind; but the days are short and the nights long. In the last week the young operator should examine himself as to his professional and intellectual progress during the bye-past year, and form plans for further improving himself for the year to come. Knowledge is a lever by which a man may raise himself as high as he desires.
Edinburgh	38 9	- -	29 66	2.598	
Dublin -	36 34	- -	29 723	2.916	

1. *Calendar of Animated Nature round London.*
 The mole (*Talpa europæa*) throws up hillocks. The December moth (*Eriogaster populi* *Sum.*) appears about the beginning, and the yellow-line quaker (*Noctua flavilinea* *Sum.*) about the end of the month.
2. *Calendar of Vegetable Nature round London.*
 Some of the last month's plants continue in flower, according to the weather.
- 3, 4. *Farm-Yard* (2902.), and *Live Stock.* (6216.)
 Threshing, and otherwise preparing corn and straw for the market, and the use of the working, fattening, wintering, and store stock are the main operations. Next, the regular supply of live stock with food, and cleaning and littering them. Fattening stock should be particularly attended to, especially house lamb (7227.) and calves. (6855.)
 The supply of turnips for cattle and sheep is liable to be interrupted by severe frosts, if the precaution of housing a quantity (5420.), or setting them (5421.), is not taken in time. Where oil cake, rape cake, or dust (6094.), brewers or distillers' grains (5112.) are used, supplies must be secured; and where hogs or cattle are fed on meal and water mixed and soured, a quantity must always be kept in mixture; as a week or ten days in temperate weather, and a longer period during frost, is requisite to induce the fermentation.
5. *Grass Lands.* (5643.)
 See that they are not poached: that water furrows, gutters, drains, and ditches are in repair; and where manuring is practised, cart it out in frosty weather where there is no danger of injury from the feet of horses or cart-wheels. Unless labour is very cheap, carting earths or earthy composts on grass lands will not pay the expenses; they produce more effect on arable lands.
6. *Arable Lands.* (4925.)
 See that all the modes of drainage are effective. (4278.) Plough and cart out manure according to weather and other circumstances.
7. *Fences* (2960.), *Roads* (3523.), and *Drains.* (4213.)
 Plant hedges (2977.) and build walls only in temperate weather, as frosty air injures the roots of plants, and freezes humid mortar, thereby effectually preventing its setting. Roads and drains may be made and mended in all weathers that admit these operations.
8. *Orchards* (4079.) and *Hop-grounds.* (5997.)
 Clear old trees of moss or misletoe; but prune only in mild weather. Dig and dung at any time.
9. *Wood-lands and Plantations.* (3906.)
 Fell timber or copse of sorts not adapted for barking. (4044.) Stock or grub up tree roots, stacking them for fuel or charcoal. (4068.) Trench, dig, or otherwise prepare ground for planting; but lift plants from the nursery, and re-insert them in plantations only in mild weather, and when the soil does not poach by treading, &c. The rest as in November.

Evergreens, as Mr. M'Nab has ably shown and proved by experience, may be planted at any period during winter, when the weather is mild. He says, "I have planted evergreens at all seasons of the year with nearly equal success, except from the middle of June to the middle of August, and even during this period I have planted some: but unless the weather is very dull and moist, and even with such weather, it is difficult to prevent the plants suffering considerably, and in many cases it is years before they recover. Although, however, I have planted evergreens ten months out of the twelve, with little difference in the success, yet one season has a preference over the others with me; and when there is the power of choice, I would recommend late in autumn, winter, or early in spring; that is, any time from the middle of October to the middle of February, and in general the beginning of this period is the best; that is, from the middle of October to the middle of December, always providing that the weather and the ground are favourable; that is, supposing there is no frost, no drying wind, nor much sunshine, and that the ground is not too much saturated with wet, either from continued rain, or from the nature of the soil. One of the principal things to be attended to in planting evergreens is, to fix on a dull day for winter planting, and a moist day for spring and autumn planting. There can be no secret in the proper treatment of evergreens; if there were, I should say, that it is in preventing their roots becoming dry when out of the earth; to choose moist and cloudy weather for planting; and still better, if we had the power, by foresight or otherwise, to secure a continuance of such weather some time after they have been planted." (*M'Nab's Hints on the Planting and General Treatment of Hardy Evergreens in the Climate of Scotland, &c.* p. 17.)
 Mr. Cruikshank has shown that poor waste ground, which, if trenched or ploughed would not bear a crop of grain, will, after being planted and kept under wood for some years, become fit for every purpose of agriculture. "On a rising ground, not far from the village of Ellon, a piece of ground of a dry gravelly nature, which has lately been cleared of a crop of full-grown Scotch firs, was trenched in a very partial and imperfect manner, the roots of the trees being scarcely eradicated. It was then sown with oats, without receiving lime, dung, or manure of any other description; yet the crop was so luxuriant, that a great part of it lodged. The following spring, the ground was again sown with the same species of grain, without receiving any enrichment; and, when harvest arrived, the crop was unequalled by that of the richest fields, in a neighbourhood which is generally considered fertile. The experiment was tried a third time, still without manure, and the return was again considerably above an average. The soil, as has already been remarked, was dry and gravelly, and far from possessing any natural qualities that could have been the cause of such extraordinary productiveness. When planted, it had been covered with heath, and in that state had not been superior to those waste lands which we occasionally see improved at a vast expense, and which will produce no kind of crop till they receive a great quantity of manure." (*Cruikshank's Practical Planter, &c.*)

GLOSSARIAL INDEX.

*** In this Index both Pages and Paragraphs are referred to ; the letter p. is prefixed to the former, to the latter the letter s.

- A**
ABRADING earth, earth crumbling down from the effects of frost, page 483.
Absorbent soil, soil so constituted as to absorb moisture from the atmosphere, 772.
Absorbent system, explained in s. 6352. p. 968.
Acclimatizing vegetables or animals, inuring them to a climate in which they are not indigenous. The term naturalising is sometimes substituted, but erroneously. See *Naturalising*.
Acescent, entering a state of acid fermentation, s. 6978. p. 1036.
Aëration, exposing the soil to the air, p. 507.
Aërometric beads, hollow beads of glass containing air, for ascertaining the specific gravity of milk, s. 7008. p. 1039.
After-grass, the second crop of grass from lands which have been previously mowed the same year, p. 905.
Aftermath, the second mowing of perennial meadow lands in the same season, p. 515.
Agriculture is used in its most extensive sense in the third line of the title-page, and generally in the historical part of the work (Part I.), as including territorial economy and husbandry. In most parts of this work, for example, in the words of the title-page, "animal and vegetable productions of agriculture," as synonymous with husbandry. In several places as synonymous with aration; that is, the culture of arable lands, as opposed to pasturage, or what may be called agriculture proper. In every case the reader will be able to gather, from the scope of the sentence or paragraph containing this term, in which of these three senses it is meant to be understood.
Agrettes, tufts of feathers, p. 1088.
Aits, small islands, or islets, in streams.
Alburnous parts, soft woody parts, p. 661.
Alburnum, the soft sappy wood just under the inner bark, p. 646. See *Lindley's Outlines of the Principles of Botany*, p. 17.
Alien waters, a brook or stream passing from one area through another, which has been embanked from a river or the sea, p. 715.
Allodially, independently of any superior, p. 552.
Alluvial soil, soil deposited by streams, p. 747.
Aloetic purge, a purge composed of the socotorine aloes, p. 1035.
Alterative, alterative medicines are those which induce a change in the blood and juices for the better, without any manifest operation or evacuation, p. 977.
Alveolar sockets, sockets like the cells in a honeycomb, p. 972.
Ambling, explained, s. 6666. p. 1002.
Amerciament, a pecuniary punishment arbitrarily imposed, p. 769.
Ammoniacal gases, s. 6701.
Amorphous stones, without regular shape, s. 3005. p. 483.
Anbury, an excrescence in some plants of the natural order Cruciferae, and chiefly in the turnip, produced by the puncture and depositing of the eggs of an insect, s. 5437. p. 861.
Animé, a chemical product obtained from plants, s. 1468.
Anomalous, irregular, p. 682.
Aorta, the great artery of the heart, p. 967.
Aorta ascendens, the ascending great artery of the heart, p. 967.
Aorta descendens, the descending great artery of the heart, p. 967.
Appui, a reciprocal action between the mouth of the horse and the hand of the rider; the bit and rein forming the line of communication. Thus a horse with a sensitive mouth has a good appui, and the same may be said of the rider if his hand be good, s. 6663. p. 1002.
Aqueous humour, the watery humour of the eye; the first or outermost, and thinnest of its three humours, p. 970.
Aration, ploughing or tillage, s. 3562. p. 573.
Arenarious grasses, grasses suitable for sandy soils, p. 749.
Averruncator, a pruning instrument, consisting of two blades fixed on the end of a rod, acting like scissors, by means of a line fixed to one of them, and pulled by the operator, s. 3155. p. 512.
Awms, the beards or long bristles which project from the chaffs; they are plentiful on spring wheat, and on barley, p. 812.
Axillaries, explained, s. 6344. p. 967.
Azote, the radical principle of the atmospheric air, p. 814.
- B.**
- Backing a horse**, explained, s. 6657. p. 1000.
Back-raking, an operation in farriery, by which hardened faeces are withdrawn from the rectum, s. 6543. p. 990.
Back-rents, rents paid subsequently to reaping, p. 768.
Bagging, explained, s. 3173. p. 575.
Bails, a substitute for fixed standings or stall divisions, s. 6799. p. 1006.
Band-win ridges, ridges formed of such a width as to be reaped by what in Scotland is called a band of shearers or reapers, s. 3250. p. 526.
Barbs, explained, s. 6382. p. 972.
Bastard-cocks, small preparatory haycocks, s. 5797. p. 904.
Battering, as applied to fences, leaning inward, s. 4594. p. 754.
Baulk, in Scotland, ground left unturned between the furrow-slices in ploughing, p. 711.; in England the same thing, and also strips of ground usually in grass between ploughed ridges, as in common field lands.
Bavins, brush-faggots, s. 3626. p. 584.
Bear, an iron instrument used in the Isle of Ely to eradicate weeds in water-courses, s. 5686. p. 892.
Bents, the dead stems of grass in pasture grounds which have borne seeds.
Bigg, a variety of winter barley, s. 5085. p. 823.
Billet, a term variously employed. A wooden billet is often used in docking a horse, and often forms a separation between carriage horses, s. 6733. p. 1009.
Binding and stooking, binding sheaves of corn, and placing them in shocks or stooks, s. 3175. p. 515.
Binot, a variety of double mould-boarded plough, s. 2620. p. 396.
Blanch holding, a mode of legal tenure in Scotland, s. 3401. p. 552.
Blast, a disease in the stomach of sheep and oxen from wind; also a term for the mildew in wheat, p. 1065.
Blinding, filling up interstices between stones on roads with gravel, &c. s. 3654. p. 589.
Blood spavin in horses, 961.
Blowing lands, lands whose surface-soil is so light as to be liable, when dry, to be blown away by the wind, p. 870.
Blowing sand, p. 749. See *Blowing lands*.
Boles of trees, the trunks of trees, p. 656.
Boll, a measure for corn in Scotland; in wheat and beans, equivalent to four Winchester bushels; in oats, barley, and potatoes, to six bushels, p. 842.
Bone spavin, explained, s. 6507. p. 986.
Boulder stones, large round stones, p. 481.

Bout of the plough, the going and returning with the plough along a land or ridge under ploughing, s. 3266. p. 529.
Box drains, explained, s. 3607. p. 581.
Boyn, a vat or tub, s. 7064. p. 1045.
Brairds, from braird, to spring up, s. 5397. p. 857.
Brake, a large harrow, s. 2664. p. 405. In machinery, a constraining wheel divided into joints, which stops when needed another wheel that revolves within it.
Bramble bonds, bands made of the long shoots of the bramble or blackberry, s. 3191. p. 518.
Braxy, explained, s. 7258. p. 1065.
Break-share, explained, s. 7259, 7260. p. 1065.
Breasting over a hedge, cutting it down, p. 489.
Breechin, that part of the horse's harness attached to the saddle, and hooked on the shafts, which enables him to push back the cart or other machine to which he is harnessed.
Breeding in the line, or in the same line, explained, p. 301.
Breeding in and in, explained, p. 301.
Breeding, cross, explained, p. 301.
Brochen ligger, a quarter-cleft rod, as thick as the finger, and four feet in length, used in thatching, p. 518.
Brose, a Scotch dish made by pouring boiling water on oatmeal, and sometimes on the meal of peas, and immediately mixing them by stirring; leaving the meal in small knots or lumps about the size of marbles. It is afterwards eaten with milk or butter, s. 5217. p. 837.
Burgage-holding, explained, s. 3404. p. 552.
Butts, short angular ridges, short irregularly shaped lands or ridges in the corners of fields, s. 3253. p. 527.
Byrc, cow-shed, s. 6777. p. 1015.

C.

Cadence, as applied to horsemanship, an equal measure or proportion observed by a horse in all his motions when he is thoroughly managed, and works justly at a gallop, *terra a terra*, so that his motions or times have an equal regard to each other, s. 6672. p. 1003. See *Crabb's Technological Dictionary*.
Caissons, temporary chests in which foundations in deep water are built, s. 4357. p. 718.
Calcareous soil, soil abounding with lime, p. 775.
Callipers, or calibers, explained, s. 4075. p. 663.
Calorifère, from *calor*, heat, and *fero*, to bear, explained, s. 7464. p. 1087.
Camping potatoes, explained, s. 5345. p. 851.
Canon of the horse, explained, s. 6232. p. 959.
Cattle, the protuberant part of the saddle behind, s. 6675. p. 1003.
Capillaries, the hair-like extremities of the arteries and veins, s. 6352. p. 968.
Cap of straw, explained, s. 3195. p. 518.
Caprioles, leaps made in one and the same place without advancing forward, s. 6672. p. 1003. See *Crabb's Tech. Dict.*
Capulet, explained, s. 6512. p. 997.
Carotid arteries, two principal arteries which carry the blood to the head, s. 6398. p. 972.
Carotids, 967. See *Carotid arteries*.
Carpus, explained, s. 6317. p. 965.
Carriage in irrigation, explained, s. 4408. p. 726.
Carse, explained, s. 4554. p. 747.
Caruncula lachrymatis, explained, s. 6370. p. 970.
Caseous, of the nature of cheese, s. 6979. p. 1036.
Castrate, to incapacitate male animals from engendering offspring, s. 7306. p. 1069. See *Spay*.
Catch-drain, explained, s. 4419. p. 727.
Catch-work meadows, explained, s. 4428. p. 727.
Cavesson, a sort of nose band, either of iron, leather, or wood, fastened round the nose of a horse to forward the suppling and breaking of the horse, s. 6657. p. 1001. See *Crabb's Tech. Dict.*
Cellular membranc, an important membrane in animals in which the fat is lodged, p. 785.
Cereal grasses, the kinds producing corn, p. 723.
Cerebral hyatids, explained, s. 7267, 7268. p. 1066.
Cervical ligament, an aponeurosis or strong bandage of packwax, which runs along the neck and upholds the head, p. 972.
Chambrière, a kind of long whip used in riding houses, s. 6662. p. 1001.
Char wood, to, to partially burn it to enable it to resist wet, s. 3039. p. 492.
Charlock, the *Sinapis arvensis*, a wild species of the mustard family, p. 880.

Chloride of calcium, quicklime, s. 4988. p. 810.
Chyle, a milky fluid secreted from the aliments in the lacteal vessels.
Chyme, that poultice-like mass to which the food is reduced in the stomach of every animal, s. 6404. p. 975.
Cicatrise, to heal over with a scar, p. 513.
Cilia, eyelashes, p. 970.
Claveau, explained, s. 7248. p. 1065.
Clinches, cramps or holdfasts; to clinch, to turn the points of nails which have been driven, as in the shoeing of horses, s. 6710. p. 1007.
Clough, explained, s. 4455. p. 732.
Cob, a kind of wicker basket, made so as to be carried on the arm; hence a seed-cob, or seed-lip, is a basket for sowing from, p. 378.
Cockle oast, a kind of kiln for drying hops upon, s. 6043. p. 927.
Coff, a Cornish term for offal pilchards, p. 1172.
Coffin bone, a bone in the foot of the horse, s. 6417. p. 976.
Coherent soil, a soil whose parts stick together, p. 772.
Collar-blade or *haims*, short segments of wood or metal, embracing the neck of the horse, to which the traces are attached, s. 3235. p. 524.
Collop, explained, s. 7871. p. 1200.
Commutation of tithes, the substituting a fixed money payment, or a portion of land, instead of a tenth of the produce.
Concha cartilages, the gristles of the ear, s. 6764. p. 1013.
Condition of a horse, the state of health and strength, p. 977.
Consecutive, following, p. 525.
Copyhold, explained, s. 3395. p. 552.
Córdæ vocâles, or *chórdæ vocâles*, tendons called into action by braying in the ass, s. 6765. p. 1013.
Córnea, the first or outer coat of the eye, s. 6371. p. 970.
Cornetti, a mode of riding, s. 6672. p. 1003.
Corollary, a consequent truth gained from some preceding truth or demonstration, s. 4961. p. 804.
Coronal roots, explained, s. 4983. p. 808.
Coronary, explained s. 6417. p. 976.
Cotyledon, the first or seed leaf or seed lobe of a plant.
Couples, chains, collars, or mechanical contrivances, by which dogs, &c. are coupled together.
Courses, explained, s. 3189. p. 518.
Crest, upper part of a hedge-bank, p. 483.
Croppers, a variety of pigeon, p. 1095.
Cross-brceding, explained, s. 2023. p. 301.
Crown and furrow-ploughing, explained, s. 3256. p. 527.
Crown scab, a disease in the horse, p. 1007.
Crystalline humour, explained, s. 6374. p. 970.
Culmi, stems of grasses, p. 1167.
Culmiferous crops, crops of plants whose stems yield straw, as wheat, barley, &c., p. 768.
Curb, explained, s. 6513. p. 987.
Curl, explained, s. 5371. p. 854.
Curvilinear, formed of curved lines.
Cut over, to cut off the top crop, s. 4043. p. 658.
Cutting in horses, explained, s. 6529. p. 988.
Cut-water of a bridge, the projecting part of the pier of a bridge, which is opposed to the current, and divides it, s. 3612. p. 582.

D.

Dandriff, scurf, s. 6738. p. 1006.
Dashing, or dashed. See *Lipped and harled*.
Dead hedges, hedges made with the prunings of trees, or with the tops of old hedges which have been cut down.
Dead timber, any timber not growing, p. 502.
Deciduous, shedding the leaves in autumn.
Decorticated, deprived of the bark, p. 655.
Defecation, explained, s. 4591. p. 867.
Dendrometer, an implement invented to ascertain the quantity of timber in standing trees, p. 663.
Deportation, carrying away, removal, p. 519.
Dew-retting, spreading hemp or flax on grass to expose it to the action of the dews, which expedite the separation of the fibre from the feculent matter, s. 5904. p. 916.
Dewstone, the name of a species of limestone in Nottinghamshire, s. 3639. p. 587.
Diagram, an explanatory sketch, p. 757.
Diarrhœa, explained, s. 6473. p. 983.
Diastole, explained, s. 6351. p. 968.
Digging his toes, in horses, explained, s. 6289. p. 960.
Dike, explained p. 496. In Cambridgeshire a ditch is called a dike.

Dicecious plant, a plant bearing its male blossoms on one plant and its female on another, s. 3181 p. 517.
Disbarked timber, timber deprived of its bark, s. 4053. p. 660.
Dished, applied to a wheel, explained, s. 3732. p. 605.
Dishes, in farming, hollow places in the fields, in which the water lies, p. 802.
Diuretics, food or drink causing a copious discharge of urine, s. 6410. p. 975.
Docking and nicking, cutting off part of a horse's tail, and cutting a notch or nick on the under side of what remains, for the alleged purpose of making him carry it well; now almost obsolete, s. 6669. p. 1002.
Domical, shaped like a dome or an arch, s. 4507. p. 740.
Dorsal vertebræ, joints of the back bone, s. 6764. p. 1013.
Double broaches, broaches or splits are two-foot lengths of split hazel branches, employed in thatching, p. 578.
Double wind-rows, double ranges of new-made hay, s. 5797. p. 904.
Dowel together, to join so closely as to form a smooth surface, s. 3710. p. 600.
Down shares, breast ploughs to pare off the turf on downs, s. 3215. p. 521.
Dragoon, a variety of pigeon, p. 1095.
Drain sluice, explained, s. 4409. p. 726.
Draw cut, explained, s. 3151, 3152. p. 512.
Droschys, the name of a four-wheeled carriage in Russia, s. 6741. p. 1010.
Dry stone walls, walls built without mortar; a common practice in stony countries, s. 3065. p. 497.
Duodenum, the first of the intestines, and connected with the stomach, s. 6405. p. 975.
Duct, a passage through which any thing is conducted.
Dynamometer, or draught machine, explained, s. 2563—2565. p. 385.

E.

Earth, as applied to the surface of the globe, one or more of the earths, as lime, clay, sand, &c., in a friable or divided state, and either alone or mixed; but without the addition of much organic matter.
Emphysematous swellings, swellings filled with a windy humour, s. 6946. p. 1033.
Enteritis, explained, s. 6466. p. 982.
Ergot of rye, spur of rye; a disease in the kernels of that grain, p. 822.
Erica, the larva state of insects, p. 1112.
Estuary, an arm of the sea, the mouth of a lake or river in which the tide ebbs and flows, s. 3425. p. 555.
Etiolated, drawn out into a weak state, p. 808.
Eustachian tube, explained, s. 6385. p. 972.
Evolve, to unfold, disentangle, develop, or separate.
Eye in plants, a bud.
Eyes in cheese, explained, s. 7067. p. 1046.

F.

Fagri, or shagreen, ass's skin, s. 6757. p. 1012.
False ribs, explained, s. 6312. p. 964.
Farcy, explained, s. 6495. p. 985.
Farmer (from *fermier*, Fr.), farming agriculturist, farming cultivator, professional farmer, commercial farmer, rent-paying farmer, &c.; a proprietor cultivating his own estate is not correctly speaking a farmer; to be such he must pay a rent. A proprietor who cultivates his own soil may be a gentleman or yeoman agriculturist or husbandman, a *propriétaire cultivateur*, but not a farmer.
Farmery, the homestall or farm-yard, p. 677.
Farming, renting land and cultivating it, or employing it for the purposes of husbandry.
Feather boarding, sometimes called weather boarding, boarding, in which the edge of one board overlaps a small portion of the board next it.
Feculence of cider, the lees or dregs, p. 673.
Fee farmhold, explained, s. 3394. p. 551.
Feeding pastures, pastures used for feeding stock, p. 905.
Feiring, explained, s. 3251. p. 527.
Felon, a disease in cattle, explained, s. 6942. p. 1032.
Femur, the thigh-bone, p. 965.
Ferruginous waters, water impregnated with iron, p. 724.
Feu-holding, explained, s. 3402. p. 552.
Feu a house, to hold a house on a feu right, s. 3861. p. 624.
Fibula, explained, s. 6327. p. 965.
Fileuse, explained, s. 7599. p. 1105.

Finched, explained, s. 6779. p. 1015.
Fingers and toes, explained, p. 861.
Finikins, a variety of pigeon, p. 1095.
Finos, the second best wool off Merino sheep, s. 7140. p. 1052.
Firlot of tares, a measure used in Scotland, in wheat and beans, equivalent to the English bushel, s. 5268. p. 842.
Flakes, hurdles or portable pales for fencing, s. 3046. p. 493.
Fleaking, explained, s. 3190. p. 518.
Fleeced cattle, explained, s. 6780. p. 1015.
Flight. See *Glume*.
Flooders, explained, s. 4449. p. 731.
Flow bog, or flow moss, a peat bog, the surface of which is liable to rise and fall with every increase or diminution of water, whether from rains or internal springs, s. 3028. p. 585.
Flowing meadows, explained, s. 4427. p. 727.
Fluke, a disease in sheep, p. 1049.
Fluke worms, animals of the genus *Fasciola*, s. 7271. p. 1066.
Fœtus, a young animal in the womb, p. 976.
Fogging pasture lands, explained, s. 5837. p. 908.
Foliage crops, plants cultivated for their leaves to be used green, and which will not make into hay, as the cabbage tribe.
Foot rot, explained, s. 7266. p. 1066.
Forage plants. See *Herbage plants*.
Fore-rents, rents paid previously to the first crop being reaped, p. 767.
Fors and scudda, explained, s. 7137. p. 1052.
Forsing, explained, s. 7137. p. 1052.
Founder of the feet of horses, explained, s. 6517. p. 987.
Free martin, explained, s. 6824. p. 1021.
Freehold, explained, s. 3393. p. 551.
Fret, colic, gripes, or gullion.
Friable soils, crumbling soils, p. 802.
Frondose branched trees, full of branches, which are flat and spread horizontally, like the fronds of ferns, as in the spruce fir, s. 3987. p. 648.
Frontal worms, explained, s. 7270. p. 1066.
Frustum, a piece cut off from a regular figure, s. 3732. p. 605.
Furnished, explained, s. 6247. p. 955.
Fusiform root, shaped like a spindle, as the carrot, parsnep, &c. p. 865.

G.

Gaites, single sheaves tied in a particular manner, p. 516.
Gaiting, explained, s. 3176. p. 516.
Gangs, courses or slips in thatching, p. 518.
Gastric juice, the juice of the stomach of any animal, p. 974.
Gaw furrows, explained, s. 4956. p. 803.
Gelding ant-hills, explained, s. 5778. p. 902.
Gean, wild cherry, s. 3994. p. 650.
Gibbous, protuberant, bearing excrescences, s. 6775. p. 1014.
Gid, explained, p. 1066.
Glair, the mucous evacuation in the scouring of horses, s. 6950.
Glanders, explained, p. 985.
Glenoid, the hollow or socket in one bone at a joint which receives the knob, boss, or head of the approximate bone, p. 965.
Glumes, the husks or chaff of corn. Oat flights are the glumes of the oat, p. 888.
Gluten, a tenacious, ductile, and elastic substance, forming a constituent part in wheat flour and other vegetable bodies, p. 771.
Go-downs, explained, s. 6736. p. 1010.
Goggles, explained, s. 7267. p. 1066.
Grass-cocks, hay-cocks, p. 904.
Grasses, all the natural order of Gramineæ, of Linnæus and Jussieu. Cereal grasses, those grown for bread corn. Pasture grasses, those grown chiefly for pasturage. Fœneous or fœniferous grasses, those grown chiefly for hay.
Grassing flax, bleaching it on the ground, p. 915.
Grease, a disease in horses, explained, s. 6514. 6516. p. 987.
Great rot, explained, s. 7261. p. 1065.
Green acres, land capable of tillage, p. 1206.
Grouting, filling up, s. 3711. p. 600.
Gutta serena, explained, s. 6441. p. 980.
Gutter, a furrow-channel or drain, s. 4418. p. 726.
Gypsum, a genus of calcareous earths, consisting of carbonate of lime, and united with sulphuric acid. The principal species is the *Gypsum Alabastrum*, plaster of Paris, or alabaster. See *Crabb's Tech. Dict.*

H.

- Ha-ha*, a sunk fence, p. 474.
Hacking and picking. See *Picking*.
Hainault mowing, explained, s. 3172. p. 515.
Hammel, a small shed, with a yard for feeding one, or at most two animals, p. 469.
Hands of tobacco, leaves tied up by their footstalks, so that the leaves spread out like the hand, s. 3945. p. 641.
Hangs, slopes, s. 3945. p. 641.
Harled, p. 497. See *Lipped*.
Hash, explained, s. 2716. p. 419.
Hatches, flood-gates, p. 726.
Hatted kitt, explained, s. 7105. p. 1048.
Hattocks, shocks, s. 3173. p. 515.
Haulm, the base of the stalks or stems of all crops, after the seeds are reaped or gathered. The haulm of peas is in some places called pea ryse.
Head and heel of gates, explained, p. 500.
Heading down trees, lopping or cutting off the heads of trees, p. 651.
Heading sheaves, the hood sheaf or sheaves of shocks of corn, p. 515.
Headmain, explained, s. 4411. p. 726.
Hockles, iron combs, p. 923.
Heckling flax, combing, p. 916.
Helmets, a variety of pigeon, p. 1095.
Hepatic affections, affections of the liver, p. 1037.
Herbage plants, forage plants, such as clover and other plants cultivated chiefly for the herb, to be used either green or made into hay.
Hide-bound, a disease in horses and cattle when the skin cleaves to the sides, s. 6425. p. 977.
Hink, explained s. 5171. p. 832.
Hinny, explained, s. 6768. p. 1013.
Hirsel, a Scotch term of the same meaning as the English term "herd," s. 6793. p. 1017.
Hoars, thick mists, p. 772.
Holmes, small islands, but larger than aits.
Hood-sheaf, a sheaf placed on the summit of other sheaves for a covering, p. 516.
Hook bones, bones in the hind quarter of cattle, s. 6799. p. 1018.
Horny frog of the horse, the prominence in the hollow of a horse's foot, p. 976.
Horsemen, a variety of pigeon, p. 1095.
Horses, pieces of wood used in barking trees, p. 659.
Hot fur, explained, s. 5906. p. 824.
Hot yellows, explained, s. 7256. p. 1065.
Hove, explained, s. 7254. p. 1065.
Huckaback, a kind of cloth, s. 5933. p. 917.
Humerus, the arm bone, p. 965.
Hummelling machine, explained, p. 440.
Hunger rot, explained, s. 7264. p. 1066.
Hungry soil, barren soil needing much manure, p. 773.
Husbandman, one who farms generally; that is, who both produces corn and cattle, and attends to the dairy, the poultry, the woodlands, and the orchard. A farmer may confine himself to grazing, or to breeding or haymaking or milking or raising green crops for the market, &c., but in none of these cases can he with propriety be called a husbandman. This term husbandman, therefore, is not exactly synonymous with farmer.
Husbandry, the culture of arable grass and woodlands, the management of live stock, the dairy, poultry, &c., and, in general, what constitutes the business of the head of a family living by agricultural industry in the country.
Hybrid, bastard or spurious, p. 1013.
Hydatid, the *Tænia glóbulus*, an insect occurring in the skull of the sheep, p. 1049.
Hydropic rot, explained, s. 7261. p. 1065.
Hygrometer, an instrument for ascertaining the degree of moisture in the atmosphere, p. 773.

I.

- Imàgo*, the perfect state of insects, p. 1112.
Impinge, to strike against, s. 4361. p. 719.
In and in system of breeding, p. 301.
Incision of objects on roads, the marks, traces, tracks, or ruts made, s. 3571. p. 575.
Increments, proportional rates of increase, s. 3552. p. 572.
Indigenæ, peculiar to, springing out of the nature of, p. 1012.
Induration, hardening, p. 717.
Infield, an obsolete Scottish term for enclosed lands near the farmstead, as opposed to such as are at a distance from it, and uninclosed, s. 802. p. 130.
Ings. See *Sittings*.

- Iris*, the coloured circle in the eyes of animals, s. 6371. p. 970.
Isometrical perspective, explained, p. 472.
Isosceles triangle, a triangle which has only two of its sides equal, p. 503.
Itinerating libraries, libraries, the books of which are carried from one place of deposit to another, and thence issued, p. 756.
Jacobines, a variety of pigeon, p. 1095.
Jumper, a tool used by masons for boring holes in land stones to be refit by gunpowder, p. 743.
Jumping pole, a long stiff pole, by which persons in the fens are enabled to jump across ditches or drains twenty feet wide, by planting the pole towards the middle of the drain, and springing from bank to bank: a small piece of board, called a quant, is fastened to the bottom of the pole to prevent its sinking into the mud. See *Quant*.

K.

- Kelp*, the ashes of any description of *Fùci* or other seaweed, p. 1205.
Knees for ship-building, crooked pieces of timber, having two branches or arms, and generally used to connect the beams of a ship with her sides, s. 3034. p. 491.
Knuckering, explained, s. 6387. p. 972.
Kyloes, the name given to the cattle of the Hebrides, s. 6796. p. 1018.

L.

- Lachrymal gland*, the gland which secretes or supplies the *lachrymæ* or tears, p. 970.
Lacteals, the absorbents of the mesentery, which originate in the small intestines, and convey the chyle from thence to the thoracic duct, p. 968. See *Crabb's Tech. Dict.*
Lactometer, explained, s. 7008. p. 1037.
Lampas, a swelling of the wrinkles or ribs in the roof of the horse's mouth; analogous to the gum-boils in man, p. 980.
Land, a term employed in Cambridgeshire and other counties, to designate what more generally is termed a ridge; that is, one of those compartments which lie between gutter and gutter in arable fields. The ridge, in Cambridgeshire, is the highest part or central line of the lands, just as the ridge of a house is the highest part of its roof. In Scotland, a ridge includes the whole of the surface between gutter and gutter. Land appears the fitter term.
Land, ground, earthy surface in opposition to water or rocks. The term ground is generally applied to a comparatively limited extent of surface, as garden grounds, hop grounds, &c. in opposition to arable lands, wood lands, &c.
Land-fast stones, stones fixed or imbedded in the soil, p. 483.
Land-reeve, explained, s. 4638. p. 760.
Larvæ, the grubs, maggots, or caterpillars of insects, 803.
Laryngeal sonorous sacs, hollows in the windpipe which modulate the voice of animals, s. 6764. p. 1013.
Larynx, the windpipe or trachea, p. 972.
Lateral shoots, shoots emitted on the sides of branches; laterally; quite distinct from latter shoots, with which they are occasionally confounded, p. 478.
Laying in hedge-planting, laying down the sets or plants horizontally on the bed prepared for them, s. 3944. p. 640.
Laying an old hedge, explained, s. 3026. p. 490.
Leaping ill, explained, s. 7253. p. 1065.
Leasehold, property held on lease, p. 552.
Legget, explained, s. 3193. p. 518.
Leguminous crops, crops of the various kinds of pulse, as peas, beans, tares, saintfoin, lucern, clover, &c., p. 800.
Levelling, explained, p. 535.
Leverage, the act of using levers, or the power acquired by the use of them, p. 575.
Light-lyered, the dew-lap of a light colour, s. 6798. p. 1018.
Ligneous plants, woody plants, as trees or shrubs, p. 476.
Lipped and harled, a wall built of stones without mortar, but which has the joints afterwards filled with mortar, and the whole wall plastered over with what is called rough-cast, or harling in Scotland. The mixture used for harling is lime, sand, and small stones about the size of peas. Dashing in England is the forcible casting of small stones

like the above, only washed quite clean, into the soft recent plaster of exterior walls, in order to resist the action of rain.

Loam, any soil in which clay and organic matter exist in considerable proportions, and so as to render it neither very adhesive or hard, nor soft and loose.

Lock spit, explained, s. 3823. p. 620.

Longe, a long leather thong, used in the process of longing or lunging horses, p. 1001.

Lymph, a clear, colourless, rather viscid humour, separated from the blood, and specifically heavier than water, s. 6350. p. 967.

Lymphatics, lymphatic vessels, are the absorbent vessels that convey the lymph into the thoracic duct, and form, with the lacteals, what is called the absorbent system. The use of these vessels is to draw in by a capillary attraction the fluids contained in the circumjacent cavities, p. 968. See *Crab. Tech. Dict.*

Lymphatic absorbents, 968. See *Lymphatics*, and *Lacteals*.

M.

Maceration, the act of steeping or soaking in water, p. 869.

Malic acid, an acid obtained from apples, by saturating the juice with alkali, and pouring in the acetous solution of lead, until it occasions no more precipitate. See *Crabb's Tech. Dict.*

Mallinders, a disease in horses, s. 6719. p. 1007.

Manege riding, explained, s. 6672. p. 1003.

Martingal, a thong of leather, fastened at one end to the girths under the belly, and at the other to the noseband of the bridle, to prevent a horse from rearing, p. 1001.

Maturation, the process of ripening, p. 816.

Maxillary glands, the glands belonging to the jaw bones, p. 972.

Meal of milk, the quantity yielded at one time of milking: thus, the morning meal, the evening meal, s. 7103. p. 1048.

Medulla, marrow, p. 967. In plants it signifies the pith.

Meers or meres, cattle ponds in Derbyshire, p. 735.

Memel timber, fir timber from the port of Memel in Prussia, in the Baltic, p. 504.

Mere, a lake, pool, or pond.

Mesentery, a membrane in the cavity of the abdomen attached to the vertebræ of the loins, and to which the intestines adhere, p. 975.

Meslin, a union of flocks, s. 736. p. 118.

Meslin, mesling, mescelin, maslin, or mescedine, corn that is mixed, as wheat, rye, &c., to make bread. This term occurs in old acts of parliament for the regulation of rivers, as that of the Cam; mescelin being in former days a frequent lading in that neighbourhood.

Mesta, explained, s. 736. p. 118.

Metacarpus, the shank, p. 965.

Metal bed of a road, explained, s. 3630. p. 585.

Metalliferous ores, ores which contain metals, p. 629.

Metals of a road, the material of which a road is formed, as broken quarry stone, boulder stones, and other kinds, p. 612.

Metayer system, the system of farming lands in many parts of the Continent, in which the produce is equally divided between landlord and tenant, p. 184.

Midden, dunghill, p. 807. "The midden is the mither o' the meal kist."

Milsey, a provincial term for a sieve, in which milk is strained, s. 7064. p. 1045.

Mortices, holes, cells, or receptacles made in posts, &c. to receive the tenons of rails, &c., p. 493.

Mould, organic matter in a finely divided and decomposed state, with a little earth mixed, as vegetable mould, leaf mould, peat mould, &c.

Mourat, explained, s. 7137. p. 1052.

Mow, a compartment in a barn, into which corn in the straw is stacked or packed.

Mow-burn, to heat by fermentation in the mow, p. 825.

Murrain, a wasting, contagious, and most fatal disorder among cattle, s. 6943. 7250.

N.

Naked disease, explained, s. 7264. p. 1066.

Naturalising animals and vegetables, introducing them to a new climate, in such a manner that they shall in future perpetuate themselves in that climate without the aid of man. See *Acclimatising*.

Navicular or *nut bone* of the horse, explained, s. 6417. p. 976.

Nicking. See *Docking*.

Nictitating membrane, explained, s. 6370. p. 970.

Nuns, a variety of pigeon, p. 1095.

Nurses for young plants, plants of an inferior and rapidly growing kind, planted round those which are choicer and of slower growth, both to shelter them and expedite their growth, p. 653.

O.

Obstetrics, considerations appertaining to the foaling, calving, yeanning, &c., of animals, s. 6969. p. 1035.

Odometer, from *odos*, a way, and *metro*, to measure, an instrument by which the quantity of space passed over on foot, or in a conveyance, may be ascertained, s. 2506. p. 376.

Œsophagus, the weasand or gullet, p. 972.

Omentum, the caul, p. 973.

One bout stitch, a ridgelet formed by the going and returning of the plough, s. 5235. p. 839.

Ophthalmia, an inflammation in the coats of the eye, proceeding from arterious blood got out of the vessels, and gathered together between the coats, s. 6758. p. 1012.

Optic nerve, a nerve which perforates the bulb of the eye, and communicates with the brain; so that every sensation derived from sight depends on the optic nerve, p. 970.

Outfall, the lower end of a water-course, p. 714.

Outfield, uninclosed farm lands at a distance from the farmstead, s. 802. p. 130.

Owls, a variety of pigeon, 1095.

P.

Pacing, one of the motions taught the horse, s. 6672. p. 1003.

Pancreas, the sweet bread. It is composed of innumerable small glands, the excretory ducts of which unite and form one duct, called the pancreatic duct, that conveys a fluid very similar to saliva into the intestines, called the pancreatic juice, which mixes with the chyle in the duodenum.—*Crabb*.

Panc of ground, a four-sided compartment of grass ground, adapted for irrigation, p. 726.

Panicle, an irregularly divided branch of flowers, as in the oat, p. 826.

Pantile, a gutter tile, p. 708.

Papier maché, mashed paper, which, when mixed up with glutinous substances, may be moulded into various shapes, p. 810.

Paring and burning, taking off the turf or surface of grass or waste lands, and incinerating it by means of fire, in order to prepare the soil for aration, p. 520.

Parotid glands, explained, s. 6388. p. 972.

Passaging, one of the motions taught the horse, s. 6672. p. 1003.

Pastern, explained, s. 6319. p. 965.

Patella, explained, s. 6325. p. 965.

Paucity, fewness, p. 734.

Peelers, the same as barkers. Persons employed to deprive trees of their peel or bark, p. 662.

Pellicle, little skin or coat, p. 822.

Pelt rot, explained, s. 7264. p. 1066.

Pendo, explained, s. 7267. p. 1066.

Penultimate, the last but one, p. 801.

Percolate, to strain, or trickle through, p. 581.

Percolation, the act of straining, purification or separation by straining, p. 522.

Péforans of the horse's foot, explained, s. 6420. p. 976.

Perichondrium, explained, s. 6336. p. 967.

Pericranium, explained, s. 6336. p. 967.

Peridésmium, explained, s. 6336. p. 967.

Periosteum, a general uniting membrane to bones and their appendages, s. 6336. p. 967.

Periphery, the circumference or orbit, p. 429.

Peripneumonia, explained, s. 7251. p. 1065.

Percaltic motion, the vermicular, worm-like, or creeping motion of the intestines; by which they contract their spiral fibres so as to propel their contents, p. 975.

Petits, a variety of pigeon, p. 1095.

Pharynx, explained, p. 972.

Picking and hacking, loosening with a pick-axe or mattock, and by separating with some cutting tool, s. 3322. p. 538.

Picking of hop plantations, explained, s. 6025. p. 926.

Piecework, work done and paid for by the measure of quantity, or by previous estimation and agreement,

in contradistinction to work done and paid for by the measure of time, p. 976.
Pigeon-cat, explained, s. 7540. p. 1096.
Piggery, the compartment in a farm-yard, with sties and other accompaniments allotted to pigs.
Pile, the shag or hair on the skins of animals. Each hair may be called a pile, s. 7140. p. 1052.
Pillow-slip, pillow-case, p. 1049.
Pining, explained, s. 7272. p. 1066.
Pinning, explained, s. 7260. p. 1065.
Pip, explained, s. 7525. p. 1095.
Pipe drain, explained, s. 4296. p. 710.
Pith and Pithing, by butchers, explained, s. 6308. p. 964.
Plane table, a square board with lines drawn on its upper side, used in taking angles and in measuring land, s. 2998. p. 481.
Plashing an old hedge, interweaving the stems in hedges, s. 3025. p. 490.
Plumassier, one who prepares feathers for ornamental purposes, p. 1088.
Pluviometer, rain gauge, s. 4742. p. 773.
Pneumonia, an inflammation of the lungs, p. 981.
Podders, persons employed to collect the green pods of peas off the plants, p. 837.
Polders, salt marshes in Holland and Flanders, p. 774.
Pole evil, or poll evil, a disease of the poll or head, usually at its hind part, or in the nape of the neck, s. 6442. p. 980.
Polled, hornless, devoid of horns, s. 6786. p. 1016.
Pommage, the pulpy mass to which apples are reduced by grinding in the cider counties, preparatory to pressing out the juice, p. 672.
Pommel, the prominence in the front or fore part of a saddle, p. 1003.
Potato pies, explained, s. 5344. p. 851.
Pouters, a variety of pigeon remarkable for its habit of pouting, p. 1095.
Preventive pruning, explained, s. 3990. p. 649.
Probang, a flexible piece of whalebone with a sponge fixed to the end, used occasionally in probing the throat, s. 6953. p. 1033.
Puddling, explained, p. 620.
Pulls, hills or elevated parts of a road, requiring extra pulling in draught animals, s. 3237. p. 525.
Pulmonary artery, explained, s. 6345. p. 967.
Pultaceous, of the consistence of a poultice, p. 1005.
Pumiced foot, explained, s. 6521. p. 987.
Puncta lachrymalia, explained, s. 6370. p. 970.
Pupa, the chrysalis state of insects, p. 1112.
Purchase of the bridle, the command or control of it, s. 6676. p. 1003.
Pursiveness, pursiness, shortness of breath, s. 6693. p. 1005.
Pyrites, firestone, s. 3228. p. 523.
Pyroligneous acid, acid produced by distillation of the spray of trees, p. 493.

Q.

Quadrant, a mathematical instrument; the fourth part of a circle, s. 3350. p. 544.
Quant, a small piece of board at the bottom of a jumping pole to prevent the pole sinking into the mud by the weight of the jumper's body.
Quarter-cleft rod, a measuring staff having four sides, s. 3195. p. 518.
Quartering, the division of planks of wood lengthwise into small four-sided pieces.
Quarters of the horse's hoof, explained, s. 6420. p. 976.
Quick, a live fence or hedge formed of some growing plant, usually hawthorn.
Quick bends, sharp turns, p. 573.
Quicken tree. See *Roan tree*.
Quicksct hedge, a hedge formed of sets or plants that are quick; that is, alive.
Quincunx, trees planted in rows, at the same distance between the rows that the trees are in the rows, and the trees of one row opposite the vacancies in the other, s. 3928. p. 638.
Quit-rent, a small rent or acknowledgement payable by the tenants of most manors, s. 1117. p. 179.
Quittor, explained, p. 988.

R.

Rabbit, a moulding, s. 4334. p. 715.
Rabios, explained, s. 7140. p. 1052.
Rafter, a piece of four-sided timber used in roofs.
Raftering land, ploughing half of the land, and turning the grass side of the ploughed furrow on the land that is left unploughed, p. 1166.; as applied to timber, sawing up planks of trees into pieces of greater depth than width for rafters to roof buildings.

Rake hot, to steam or reek hot, s. 6723. p. 1008
Ramose-headed trees, trees whose heads abound in branches, p. 649.
Ramosc-rooted trees, trees whose roots are much branched, p. 634.
Rath ripe, the property of being early ripe, s. 5082. p. 823.
Rat's tail, a disease in horses, which causes the hair of the tail to fall off, and not be again produced, s. 6710. p. 1007.
Ray, a disease in sheep, explained, s. 7625. p. 1066.
Rectangular fields, fields whose angles are right angles, p. 680.
Rectangular parallelogram, a figure of four sides, whose opposite sides are equal, and all its angles right angles, p. 443.
Red roan, explained, s. 5106. p. 825.
Redwater, explained, s. 5106. p. 1064.
Rête mucosum, p. 963. A mucous membrane deposited in a net-like form, between the epidermis and the cutis: it covers the sensible cutaneous papillæ, connects the epidermis with the cutis, and gives the colour to the body. — *Crabb*.
Rétina, the true organ of vision, formed by a net-like expansion of the pulp of the optic nerve, p. 970.
Rhomboid, a figure whose opposite sides are parallel and equal, but all its sides are not equal, neither are its angles right angles, p. 414.
Ribbing, explained, s. 3255. p. 527.
Ricking, explained, s. 3176. p. 516.
Riddle, a large coarse sieve, s. 3655. p. 589.
Ridging, laying the soil up in ridges, p. 508.
Rifing by gunpowder, riving, splitting, or dividing, s. 4065. p. 661.
Right angles, where a room is exactly square, each of the corners of it is called a right angle: in scientific language it is thus defined, as the fourth of a circle; or thus, when one straight line, standing on another straight line, makes the adjacent angles or corners equal to one another, each of the angles or corners is called a right angle.
Ring-bone in horses, a disease in the feet of the horse, p. 960.
Rippling of flax or hemp, the operation of separating the boles or seed pods, by striking them against a board, or piece of iron, p. 915.
Ristle-plough, explained, p. 1197.
River-meadows, explained, s. 5769. p. 901.
Roan tree, the mountain ash.
Roguish plants, spurious varieties, s. 5220. p. 858.
Rooflet, explained, s. 3195. p. 519.
Root crops, esculent plants cultivated for their tubers, bulbs, or other enlarged parts produced under or immediately on the ground, and chiefly connected with the root, as the potato, turnip, carrot, &c.
Roots, the fibres and other ramifications of a plant under ground, and by which it imbibes nourishment. Tubers, bulbs, and other fleshy protuberances under ground, are employed by nature for the purposes of propagation or continuation, and therefore ought never to be confounded with common roots, which serve to nourish these tubers, bulbs, &c., in common with other parts of the plant.
Rot, explained, s. 7245. p. 1064.
Rouen, the aftermath, the lattermath, or second crop of hay cut off the same ground in one year, s. 3169. p. 515.
Rough pile in cattle, coarse hair or wool, p. 784.
Roup, explained, s. 7526. p. 1095.
Rowels, explained, s. 6538.
Rubbers, a disease in sheep, explained, s. 7265. p. 1066.
Rubble stoncs, loose stones, brick-bats, and the like, which are put together to conduct water; so called because they are rubbed together.
Rumbling drains, drains formed of a stratum of rubble stones, p. 581.
Runner, explained, s. 4140. p. 675.
Runts, a variety of pigeon, p. 1095.
Rural economy, rural affairs, geononics, agromonics, terms considered as synonymous with husbandry.
Rust, a disease to which the cereal and other grasses are subject, and which occasions their herbage to be of a rusty colour, s. 5741. p. 899.
Rut, to cut a line on the soil with a spade, p. 482.; also the copulation of deer in the rutting season; also the track of a cart-wheel.
Rutting. See *Rut*.

S.

- Saccharo-saline*, partaking the properties both of sugar and salt, p. 1039.
- Saddle-grafting*, explained by figures, p. 1143.
- Salin*, explained, s. 5360. p. 853.
- Saliva*, the spittle of animals.
- Salt-cat*, a mixture given to pigeons to promote their digestion, p. 1096.
- Saltings* or *ings*, salt-water marshes, p. 747.
- Sanderacks*, explained, s. 6525. p. 988.
- Sauer kraut*, explained, s. 5507. p. 868.
- Scab*, explained, s. 7265. p. 1066.
- Scalene triangle*, a triangle with three unequal sides, s. 4343.
- Scantling*, all quartered timber under five inches square, s. 4002. p. 652. In masonry, a term expressive of the size of stones.
- Scarcement*, a rebate or set-back in the building of walls, or in raising banks of earth, p. 481.
- Scarification*, cutting through the bark and soft wood of a thick branch with an edge tool, previously to sawing through the hard wood, s. 3164. p. 513.
- Scapula*, the shoulder blade, p. 964.
- Scarifier*, a machine to excoriate and disturb the surface of soil, p. 528.
- Sclerotic coat*, a coat of hard consistence, p. 970.
- Scoop wheel*, a large wheel with numerous scoops fastened in its periphery, s. 4277. p. 706.
- Scoria* of founderies, the refuse or dross of the metals, s. 3643. p. 588.
- Screening*, the act of sifting earth or seeds through a large oblong sieve or riddle, called a screen, p. 509.
- Scudda*. See *Fors and Scudda*.
- Scuffler*, a kind of horse-hoe, p. 528.
- Scutching* flax, breaking the woody part of it preparatory to separating it from the fibrous parts, p. 915.
- S. a-ooze*, the alluvial deposit, the mud or slime left by the sea where its waters have subsided, p. 746.
- Seed-lobes*, the cotyledons, or very first leaves displayed on a seedling plant.
- Sellenders*, in horses, explained, s. 6293. p. 961.
- Seminal roots*, the first roots, those emitted from the seed itself, p. 808.
- Sensible frog* of the horse, explained, s. 6420. p. 976.
- Sensible lúminæ*, explained, s. 6421. p. 976.
- Septic*, causing putridity, producing putrescence, s. 6844. p. 1023.
- Serum*, whey, or the remainder of milk after its better parts have been taken away; also, the yellow and greenish fluid which separates from the blood when cold and at rest, s. 6980. p. 1036.
- Sesamoids*, little bones found at the articulation of the toes (in man); so called from their supposed resemblance to the seeds of the plant called sesamum, s. 6319. p. 965.
- Setons*, explained, s. 6537. p. 990.
- Set-sod*, explained, s. 3014. p. 486.
- Sets and eyes* of potatoes, slices of the tubers of the potato, each slice being furnished with at least one eye or bud, p. 848.
- Shab*, explained, s. 7265. p. 1066.
- Shagreen*, or *fagri*, the prepared skin of the ass, s. 6757. p. 1012.
- Shakes* in the boles of trees, fissures, clefts, or rents, p. 656.
- Shakers*, a variety of pigeon, p. 1095.
- Shaking quags*, shaking bogs; wet spongy soil, p. 694.
- Shaley soil*, explained, s. 4750. p. 774.
- Shearer*, a reaper, s. 3250. p. 526.
- Shearing*, reaping, p. 515.
- Sheath*, land guard of embankments, s. 4362. 4366. p. 719, 720.
- Shearing rivers*, the process of mowing the plants which abound in rivers; the instrument with which this is effected is formed of a line of scythe-blades, rivetted together by their extremities, and which line of scythe-blades is worked or moved along over the surface of the mud by levers attached to the line, operated upon by men in boats, s. 3171. p. 515.
- Shift of crops*, an alternation or variation in the succession of crops, p. 814.
- Shifting beach*, a beach of gravel liable to be shifted or moved by the action of the sea, or the current of rivers, s. 4332. p. 714.
- Shingles*, pieces of thin board used as tiles, a common practice in timber countries on the Continent and in America, s. 3051. p. 495.
- Shocks*, stooks or hattocks, assemblages of sheaves, never of more than ten sheaves in those places where the tithe is paid in kind, as this arrangement facilitates the taking of the tithe; in Scotland, from six to twelve, independently of the two or four hood or roof sheaves, p. 515.
- Shoughed*, earthed in, p. 640.
- Siddow peas*, such as boil freely, s. 7791. p. 1140.
- Siliceous*, of the nature of sand or flint, p. 587.
- Siloes*, repositories, explained, s. 4988. p. 810.
- Single wind-rows*, a single range of new-made hay, before it is packed into cocks, p. 903.
- Skirting* or *peat turning*, explained, s. 3210. p. 520.
- Skreen plantations*, plantations made for the purpose of skreening or sheltering, p. 753.
- Slab*, the outer board sawed from the trunk of a tree.
- Sleepers*, explained, s. 3785. p. 613. In Suffolk the root stocks, when left in the soil, of such trees as are sawed off level with the surface.
- Slip-coat cheese*, explained, s. 7085. p. 1047.
- Slit planting*, explained, s. 3953. p. 642.
- Slob farrow*, explained, s. 3213. p. 521.
- Sludger*, explained, s. 2518. p. 378.
- Snaffle*, a bridle with a single rein, and without a curb, s. 6734. p. 1009.
- Snag pruning*, pruning or cutting off branches so as to leave snags, s. 4027. p. 655.
- Snags*, stumpy bases of branches left in pruning, s. 3993. p. 650.
- Sob*, a convulsive spasm of the air passages to relieve congestion, s. 6723. p. 1008.
- Soil*, earth, either of one or of several sorts, mixed with decomposed organic matters.
- Soiling*, feeding horses or cattle in houses or sheds with clover or other herbage in a green state, p. 874.
- Sough*, a box-drain, s. 4254. p. 700.
- Sowens*, explained, s. 5146. p. 828.
- Spay*, to incapacitate a female animal for producing young, s. 7306. p. 1069. See *Castrate*.
- Sphacelated*, withered, blasted, mortified, gangrened, s. 6945. p. 1032.
- Spinous processes*, projections resembling spines or prickles, s. 6764. p. 1013.
- Spired*, grown, shot out into spires, s. 5108. p. 825.
- Spitful of earth*, a spadeful of earth, p. 507.
- Splint*, in horses, a preternatural excrescence of bone, or a hard tumour, s. 6293. p. 961.
- Spots*, a variety of pigeon, p. 1095.
- Spray drain*, a drain formed by burying the spray of wood in the earth, which keeps open a channel, s. 4284. p. 708.
- Spray of a tree*, the twigs of the branches of a tree, p. 649.
- Spring feed*, herbage produced in the spring, p. 905.
- Squeakers*, pigeons under six months of age, p. 1096.
- Stacking stage*, explained, s. 3289. p. 533. In Cambridge, the object of the stage is effected by a stage hole left in one side of the upper part of the rick.
- Stack guard*, explained, s. 3288. p. 532.
- Staddles*, explained, s. 5796. p. 903.
- Stake and rice*, a fence composed of stakes driven into the ground and interwoven with branches retaining their spray, or with rods without their spray; the latter is frequently called a wattled fence, p. 487.
- Staggers*, a disease of the horse, explained, p. 973.
- Straw mow*, a stack or rick of straw formed in a barn, s. 5045. p. 818.
- Steining a well*, lining it with stone or brick, s. 4479. p. 755.
- Stifle of the horse*, explained, s. 6276. p. 959.
- Stire*, a sort of cyder apple, s. 4082. p. 665.
- Stock*, the animals of agriculture called live stock; also, the implements and other lifeless articles of property on a farm, called dead stock.
- Stocking a pasture*, putting in as many head of cattle as the pasture will maintain, s. 5285. p. 906.
- Stolones*, the creeping rooting shoots of some grasses, and other plants, by which they increase, p. 904.
- Stoloniferous grasses*, grasses producing stolones, p. 887.
- Stone-brash*, a sub-soil composed of shattered rock or stone, s. 4519. p. 742.
- Stooks*, shocks or hattocks, p. 817.
- Stools of a coppice*, the stumpy root-stocks of trees previously cut down, p. 662.
- Stover of rape*, the pods and points broken off in threshing, p. 932.
- Strull*, a bar so placed as to resist weight, p. 498.
- Stubs*, stucky stumpy portions of the stems of trees and shrubs, p. 1009.
- Stud*, a post, a stake, an upright, in a building, p. 500.; a collection of breeding horses and mares.

Stumming, explained, s. 4132. p. 674.
Sturdy, explained, s. 7267. p. 1066.
Subcarbonate of soda, a salt in which soda predominates, p. 837.
Sublingual, under the tongue, s. 6388. p. 972.
Succedaneum, a substitute, p. 846.
Swath, the bands or ridges produced by mowing with the scythe, p. 903.
Swath balk, the line between two swaths where the stubble is cut least closely, presenting a little ridge of stubble, p. 514.
Sways, long bramble rods used in thatching with reeds, p. 518.
Sweating of hay, a slight fermentation, p. 904.
Swing plough, any plough without wheels, p. 390.
Switching bill, an instrument used in pruning hedges, p. 485.
Switching hedges, cutting off the one year's growth which protrudes from the sides of hedges, s. 4005. p. 652.
Synchronous, at one time, at the same time, contemporary, p. 1002.
Synopsis, the seeing all at once, or at one view; a comprehensive volume, p. 881.
Synovia, joint oil, p. 965, 967.
Systole, explained, s. 6351. p. 968.

T.

Tag-belt, a disease in sheep, explained, s. 7260. p. 1065.
Tail drain, explained, s. 4414. p. 726.
Tapetum, explained, s. 6373. p. 970.
Tarsus, explained, s. 6328. p. 966.
Teathing, explained, s. 5824. p. 906.
Tecernos, explained, s. 7141. p. 1052.
Tedding hay, scattering, spreading, turning, and, in short, making hay, p. 903.
Tenon, a projection in a rail, &c., made to fit a mortice.
Tenon joint, a joint formed by a tenon and mortice, p. 598.
Tenure, a holding or occupying, p. 179.
Territorial economy, whatever relates to the valuation, purchase, sale, exchange, arrangement, improvement by roads, canals, drainage, &c., of territorial surface, including interposing waters, as rivers, lakes, and also mines and minerals. Territorial improvements are mostly effected by the proprietors of lands or their agents and stewards, and not to any great extent by renters of land, or farmers.
Tétanus, a spasmodic affection, accompanied by rigidity, one species of which is known by the popular name of a locked jaw, s. 6370. p. 970.; s. 6432. p. 978; s. 6965. p. 1035.
Tethering, restraining grazing animals by a rope or chain, fastened to the animal at one end, and to the earth at the other, s. 5560. p. 876.
The line of draught, the direction in which an animal is pulling or drawing, s. 2592. p. 390.
Theodolite, an instrument used in surveying, and chiefly in taking angles, p. 544.
Thill, the beam or draught tree of a cart or waggon.
Thiller or Thill horse, the horse that is put under the thill, or into the shafts or draughts, p. 1139.
Thoracic duct, the trunk of the absorbent vessels, so called from its being placed in the thorax or chest, p. 968.
Thorough-pin, explained, s. 6293. p. 961.
Threave, twenty-four sheaves of straw or corn, s. 3168. p. 517.
Thrush paste, explained, s. 6554. p. 988.
Tibia, the leg bone, p. 965.
Ticks, a variety of bean, called the tick bean, s. 5225, 5226. p. 838.
Tie, a bar so placed as to resist a drawing or twisting power, p. 498.
Till, coarse obdurate land, p. 746.
Tiller, to send forth numerous stems from the root; applied only to culmiferous plants, s. 4984. p. 808.
Tillering. See *Tiller*, s. 5130. p. 826.
Tith, the degree or depth of soil turned by the plough or spade, that available soil on the earth's surface, into which the roots of crops strike, p. 803.
Tippling, as applied to hay-making, explained, s. 5549. p. 875.
Tithe, the tenth of the produce of the soil, paid to the clergy of England.
Tithing-man, a person employed by the clergyman in a village to set out and collect his tithes.
Torrefied earth, earth subjected to the action of fire, p. 522.
Trachea, the windpipe, p. 972.
Tracking flax, breaking the woody part in the stems of flax, s. 5912. p. 915.

Tramp, an instrument used in making hedges, p. 431.
Tramroad, explained, s. 3795. p. 615.
Translucent, transparent, diaphanous, allowing light to shine through, p. 811.
Tremblings, explained, s. 7253. p. 1065.
Trench, explained, s. 4412. p. 726. To trench, to turn over and mix soil to the depth of two, three, or more spades, or spits.
Trench drain, explained, s. 4413. p. 726.
Trindle, to allow to trickle or run down in small streams, p. 641.
Trochar, an instrument resembling a pipe, used for making incisions, when water or air is received out of the incision through the trochar, p. 1034.
Truncheons, large sets, stakes, or poles, of willow, poplar, &c. planted to form trees speedily, p. 749.
Trumpeters, a variety of pigeon, p. 1095.
Tubers, knobs, fleshy bodies at the roots of plants, as in potato, yam, pignut, &c., p. 511.
Tumblers, a variety of pigeon, p. 1095.
Turbits, a variety of pigeon, p. 1095.
Turners, a variety of pigeon, p. 1095.
Turnsick, explained, s. 7267. p. 1066.
Tussocks of grass, clumps, tumps, tufts, or minute hillocks of growing grass, p. 518.
Twibil and hink, explained, s. 5171. p. 832.

U.

Urinaryum, a receptacle for urine, s. 6998. p. 1038.

V.

Velum palati, explained, s. 6382. p. 972..
Vena cava, explained, s. 6348. p. 967.
Vena cava ascendens, explained, s. 6348. p. 967.
Vena cava descendens, explained, s. 6348. p. 967.
Vena portæ, explained, s. 6349. p. 967.
Vinuish. See *Pining*.
Viscid, thick, glutinous, gummy, p. 1036.
Vivacious, living, sprouting, very lively, very free of growth, p. 803.
Vives, explained, s. 6388. p. 972.

W.

Wads, explained, s. 5208. p. 835.
Walls dashed with lime. See *Harled*.
Walls en pisé, walls built of mud rammed in between a frame of boards, p. 457.
Warbles, explained, s. 6489. p. 984.
Ward-holding, explained, s. 3402. p. 552.
Warping, explained, s. 4452. p. 732.
Watering of hemp, the maceration, steeping, or immersion of the stems of the hemp plant, in water, s. 677. p. 107. 917.
Water-rotted, watered, s. 5929. p. 917.
Water tables across a road, sunk pannels, which conduct the surface water into drains, p. 582.
Water-tabling, explained, s. 3014. p. 486.
Watery head, explained, s. 7267. p. 1066.
Wattle, to weave, to interlace, or plat branches or rods.
Wattled fence. See *Stake and Rice*.
Wattled hurdles, hurdles wattled with rods.
Way pane, explained, s. 4416. p. 726.
Wear, a dam made with stakes and osier twigs interwoven, as a fence against water, p. 722.
Well-bred, explained, s. 2064. p. 305.
Whethering, explained, s. 6971. p. 1035.
Whin, furze, gorz, gorse, or goss, p. 510.
Whinstone, explained, s. 3654. p. 589.
Whipping out grain, striking the ears against a stone or the edge of a board, till the corn is separated from the straw, p. 519.
Whipping in plants, to bruise, abrade, or injure, by rubbing or striking against another, as the competing branches of neighbouring trees, s. 4014. p. 633.
Whirlbone of the horse, the articulation of the thigh bone with the pelvis, 959.
Whitten, the small-leaved lime, p. 1141.
Wilding, trees sprung up from seeds naturally distributed, i. e. by winds, birds, running waters, &c., p. 675.
Winlestraws, the withered flower-stalks of grasses standing in the fields; in English, bents, s. 5058. p. 820.
Wornals or puckeridge, explained, s. 6968. p. 1035.
Woodward, a land-reeve or ground officer, s. 4638. p. 760.

Y.

Yellows, explained, s. 6480. p. 984.
Yerking, one of the motions taught to horses, s. 6672. p. 1003.

GENERAL INDEX.

* * The Numbers refer to the Paragraphs, not to the Pages, except in the case of the List of Authors, where they refer to the page and the year in which the Author published: in such cases the word page and letters A.D. are prefixed.

- ABBATE**, Antonio, his work on agriculture, page 1221. A. D. 1808.
- Abeille**, F., his work on agriculture, page 1217. A. D. 1791.
- Aberdeenshire, statistics of, 7852.
- Abortion in plants, 1683.
- Abyssinia, climate, surface, and soil of, 1067; agricultural products of, 1068; live stock of, 1069; agriculture of, 1070.
- Acclimating of plants, 1764; the more tender animals, 7390.
- Account books, farmers', 4886.
- Accounts, keeping and auditing, 4708; keeping, 4883; necessity of a regular system of, 3381.
- Acid, fluoric, in animals, 1924; muriatic, in animals, 1925; pyroligneous, distillery of, at Milburn in Dunbartonshire, 7843.
- Acids, 1423; oxalic, 1424; acetic, 1425; citric, 1426; malic, 1427; gallic, 1428; tartaric, 1429; benzoic, 1430; prussic, 1431; vegetable, constituents of, 1432; animal, 1953.
- Adam**, James, his work on agriculture, page 1210. A. D. 1789.
- Adam**, of Blair Adam, 7847.
- Adams**, George, his work on agriculture, page 1212. A. D. 1810.
- Adanson**, Madame Aglaë, her work on agriculture, page 1218. A. D. 1822.
- Adansonia digitata*, 1109.
- Africa, general description of, 1066.
- After-grass on meadows, 5810.
- Agricultural Institution of Moegelin, 576.
- Agricultural Society, Australian, 1043.
- Agricultural Societies of Hanover and Celle, 593.
- Agriculture among the Romans, decline of, 178.
- Agriculture, as influenced by climate, 1248; by temperature and light, 1259; by elevation, 1260; by soil, 1263; by moisture, 1264; by the state of society, 1270; by civilisation, 1271; by political circumstances, 1272; by religion, 1273; by the character of a people, 1274.
- Agriculture, bibliography of, 7896.
- Agriculture during the seventeenth century, 234.
- Agriculture, earliest Spanish works on, 713.
- Agriculture, history of, in the ages of antiquity, 5; in Egypt, 8; among the Jews, 17; of the Greeks, 24; of the Persians and Carthaginians, &c. 36; among the Romans, 42; during the middle ages in Italy, 180; in France, 185; in Germany, 192; in Britain, 195; in ultra-European countries, 47.
- Agriculture, improvement of, by refining the taste of the purchasers of its products, and increasing the knowledge of agricultural patrons, 7926; by the better education of those engaged in it, 7930.
- Agriculture in England during the thirteenth and fourteenth centuries, 210; in the fifteenth century, 211; in the sixteenth century, 216; early in the sixteenth century, 221; during the reign of Elizabeth, 222.
- Agriculture in ultra-European countries during the middle ages, 257, 258.
- Agriculture may be practised without any knowledge of its theory, 1286; object of the art of, 1287; study of the science of, 1289.
- Agriculture of Britain, classification of the, 1280; improved by the Norman conquest, 204.
- Agriculture of irrigation, geographical extension of the, 1254; of manures and irrigation, 1255; of draining and manures, 1256; of science, 1276; of habit, 1277; barbarian, 1278; of savages, 1279; of water-fed lands, 1266; of sun-burnt lands, 1267; of mountains, 1268; common, 1269.
- Agriculture, origin of and importance; practice of, in early times; recent discoveries in; arrangement of the subject in this work, pages 1 to 3; the operations, 3111; the physical circumstances affecting, 1258; traditional history of, 1, 2; works on, during the commonwealth, 250.
- Agriculturists, commercial, the different kinds of, 7724; itinerant, 7725; professional education of, 7942.
- Aigoïn**, his work on agriculture, page 1218. A. D. 1805.
- Ainslie**, John, his works on agriculture, page 1212. A. D. 1806.
- Air, fresh, proper for domestic animals, 2076; noxious in wells, 4480.
- Aiton**, William, his works on agriculture, page 1212. A. D. 1805.
- Alamanni**, his work on agriculture, page 1221. A. D. 1764.
- Alamanni**, Luigi, his work on agriculture, page 1221. A. D. 1546.
- Albania, agriculture of, 758.
- Albertazzi**, Jacopo Antonio, his work on agriculture, page 1222. A. D. 1811.
- Albrecht**, J. F. E., his work on agriculture, page 1219. A. D. 1775.
- Albumen, 1344. 1406; in animals, 1939; use of, 1940.
- Alderson**, John, M. D., his work on agriculture, page 1211. A. D. 1802.
- Algæ, utility of the, 1333.
- Algiers, description of the territory of, 1095.
- Alkalies, vegetable, 1500; utility of, 1501.
- Alletz**, Pons Augustin, his works on agriculture, page 1215. A. D. 1760.
- Almond tree, the, at the Cape of Good Hope, 1122.
- Aloe, the, in Spain, 723; of the Cape of Good Hope, 1123.
- Amazonia, agriculture of, 1244.
- Ambergris, 1949.
- Ameithon**, Hubert Pascal, his work on agriculture, page 1216. A. D. 1779.
- America, agricultural operations of, 1170; field labours in, 1171.
- America, North, temperature of the eastern parts of, 2352.
- Amiot**, Le P., his work on agriculture, 1216. A. D. 1770.
- Ammonia in animals, 1929.
- Ammoniac, 1474.
- Amoretti**, his works on agriculture, page 1221. A. D. 1785.
- Amoreux**, his works on agriculture, page 1216. A. D. 1787.
- Amos**, William, his works on agriculture, page 1210. A. D. 1794.
- Amphibia, 7589.
- Analysation of plants, mechanical and chemical processes for the, 1392, 1393.
- Analysis, vegetable, products of, 1394; compound products of, 1395.
- Anderson**, James, LL. D., his works on agriculture, page 1209. A. D. 1775.
- Anderson**, William, his work on agriculture, page 1213. A. D. 1816.
- Angler, the, injurious to young salmon, 3892.
- Anglo-Saxons, origin of the, 200.
- Angus, statistics of, 7850.
- Animals affected by climate, 1249.
- Animals, androgynous, 1984; gemmiparous, 1985; hybridous, 1986; dead, as a manure, 2245; distribution of, on the face of the globe, 1999; local distribution of, 2005; domestic, the rearing of, 2066.
- Animals, external covering of, 1844; importance of, in the arts, 2013. 2019; as articles of food, 2015; in medicine, 2018; influence of soil and climate

- on the general properties of, 2024; killed by accident not unwholesome, 2097; more numerous than plants, 1998; necessity of a partial knowledge of, 1837; of Britain, 1838; noxious to agriculture, 7623; reared by the Romans, 156; the classification of, 1842; the elementary substances composing, 1917; the mode of describing, 1840; viviparous, reproduction of, 1974; vertebrated, distribution of, 2002; marine, distribution of, 2003.
- Animé, from what obtained, 1468.
- Annuaire de la Société Royale et Centrale d'Agriculture, Anon. page 1219. A. D. 1826.
- Annuaire du Jardinier et de l'Agronome, pour 1826. Anon. page 1219. A. D. 1826.
- Annuals, 1569.
- Anomalies in plants, 1589; in the parts of plants, 1320.
- Anstruther, Sir John, Bart., his work on agriculture, page 1211. A. D. 1796.
- Ant and mole hills, removal of, on pastures, 5821.
- Antelope, the, 7378; the common, 7380; the chamois, 7381; the Scythian, 7382; the white-footed, 7383.
- Ant-hills, 5775; to remove, 5776; Norfolk mode of cutting and burning, 5777; gelding, 5778.
- Antill, Hon. Edward, Esq., his works on agriculture, page 1223. A. D. 1789.
- Anton, K. Glo., his work on agriculture, page 1220. A. D. 1799.
- Antrim, statistics of, 7895.
- Aphides, the, or plant lice, 7682; of beans, 5256.
- Apiary, the, 2845. 7603.
- Apples, baking, most suitable for orchards, 4088; cider, the most approved sorts of, 4086; table of, 4089; dessert, fit for orchards, 4090; orchard, Ronalds's select list of, 4098; Pearson's select list of, 4099.
- Apple-mill, the, 4145.
- Appraiser, agricultural, 7749.
- Apprentices, agricultural, 4879. 7712.
- Apravin, M., his work on agriculture, 7907.
- Aquatics, influence of altitude on the habits of, 1737.
- Aquino, Charles d', his work on agriculture, page 1221. A. D. 1736.
- Arabia, extent of, 883; general surface of, 884; agricultural products of, 885; plants and trees of, 886; live stock of, 887; agricultural implements and operations of, 889.
- Architecture of Thibet, 1019.
- Ardrossan, the harbour at, 7841.
- Arduino, Luigi, his works on agriculture, page 1222. A. D. 1809.
- Argyleshire, statistics of, 7858.
- Armagh, statistics of, 7893.
- Armature of plants, 1318.
- Arrangement of plants, the artificial and natural, 1302 and 1303.
- Arrow-root, the, of the West Indies, 1219.
- Artichoke, Jerusalem, 5512.
- Arun esculéntum, 1217.
- Ash tree, large, in Bonhill churchyard in Dunbartonshire, 7843.
- Ashes for lixiviation, 682.
- Ashes of plants, 1498; analysis of, 1499.
- Asia Minor, climate of, 861.
- Asia, the islands of, 1020.
- Asparagus, treatment of, in the Netherlands, 493.
- Aspect in regard to farming lands, 4771.
- Assafœtida, 1482.
- Ass, the, 6756; excellencies and defects of, 6757; the different breeds or races of, 6759; breeding, 6760; breaking the, 6762; to know the age of, 6763; anatomy and physiology of the, 6764; diseases of, 1665; shoeing of the, 6766.
- Asses, the, of Egypt, 1087.
- Astrágalus bæ'ticus, culture of, 6166.
- Atmosphere, substances composing the, 2333; action of, on plants, 2344; changes in the, 2345.
- Atti del real instituto d'incoraggiamento, &c. Anon. page 1222. A. D. 1825.
- Auditor of accounts, the most essential duty of an, 4715.
- Audouin, Maurice, his work on agriculture, page 1218. A. D. 1829.
- Auger, the common draining, 4314; the horizontal, 4317; use of the, in well-digging, 4481.
- Australia, the islands of, 1034.
- Austria, state of agriculture in, 619; landed property of, 620; crown lands in, 622; appearance of the country of, 623; instruments of agriculture in, 624; agricultural produce of, 625; vine, culture of, 627; culture of plums in, 629; culture of silk in, 630; bees in, 631; live stock of, 632; horned cattle of, 633; horses of, 634; swine of, 635; poultry of, 636; the land tortoise of, 637; implements and operations of agriculture in, 638; forests of, 639; improvement of the agriculture of, 640.
- Author, the agricultural, 7757.
- Authors, agricultural, in the time of Elizabeth, 231; Roman, 44.
- Autumn, temperature of, influence of, on plants, 1729.
- Aviary, 7566.
- Avrouin, Foulin, his work on agriculture, page 1218. A. D. 1818.
- Awns of barley, method of rubbing off the, 2798.
- Axe, the, 2490.
- Axles, Burges's improvement in, 2751.
- Axle-trees, the best for preserving roads, 3737.
- Ayrshire, statistics of, 7841.
- Azote, in the atmosphere, 2341.

B.

- Bachapins, description of the, 1138.
- Bacon-grub, the, 7692.
- Badger, the, 7630.
- Bagging corn, 3174.
- Bagot, his works on agriculture, page 1218. A. D. 1805.
- Bailey, John, Esq., his works on agriculture, page 1211. A. D. 1797.
- Bailiff and gardener, 7718.
- Bailiff, choice of a, 4867.
- Bakewell, Robert, Esq., his work on agriculture, page 1212. A. D. 1808; improvements by, in the live stock of Britain, 787.
- Balsam of Peru, 1488; of Tolu, 1487.
- Balsams, 1483.
- Bamboo, the, uses of, 908.
- Banister, John, his work on agriculture, page 1211. A. D. 1799.
- Bank formed with piles, brushwood, and stones, 4350.
- Bar Loch, drainage of, 4276.
- Barbaro, Marco, his work on Agriculture, page 1221. A. D. 1785.
- Barbe-Marbois, his works on agriculture, page 1217. A. D. 1798.
- Barber, William, his works on agriculture, page 1212. A. D. 1805.
- Bard, C. P., his work on agriculture, page 1219. A. D. 1826.
- Barelle, Giuseppe, his works on agriculture, page 1221. A. D. 1807.
- Barilla, cultivation of, 6194.
- Bark of trees, drying, 4051; chopping, 4052.
- Bark, spent, tanner's, as a manure, 2242.
- Barking trees, 4050.
- Barley, frosted, 4998.
- Barley, 5080; species and varieties of, 5081; soil for, 5093; manure for, 5097; climate for, 5098; sowing, 5099; culture of, in a growing state, 5104; harvesting of, 5107; stacking, 5109; threshing and dressing, 5110; produce of, 5111; uses of, 5112; diseases of, 5119; insects injurious to, 7663.
- Barometer, use of the, 2346. 2408; the words engraved on the, 2416.
- Barron, William, F.R.S.E., his work on agriculture, page 1209. A. D. 1774.
- Barrow-drill, the turnip, 2578.
- Barrows for hay and straw 2540.
- Barthez de Marmorieres, his work on agriculture, page 1215. A. D. 1763.
- Bartley, Nehemiah, Esq., his work on agriculture, page 1211. A. D. 1802.
- Barton, Benjamin Smith, M. D., his work on agriculture, page 1223. A. D. 1812.
- Bartram, John, M. D., his work on agriculture, page 1223. A. D. 1744.
- Bartram, Moses, his work on agriculture, page 1223. A. D. 1789.
- Base of a road, preparation of the, 3622.
- Baskets, 2525.
- Bassi, Agostino, his works on agriculture, page 1222. A. D. 1811.
- Bastard saffron, 5987; soil for, 5990; use of, 5991.
- Bath and West of England society, the, 7914.
- Bauers, German, farming of the, 605.
- Bavaria, former state of agriculture in, 614; agricultural improvement of, 615; surface of, 616; crops cultivated in, 617; forests of, 618.
- Bayldon, J. S., his work on agriculture, page 1218. A. D. 1825.

- Beaks of birds, 1862.
 Beans, Carob, 1104.
 Bean drills, 2683; Weir's expanding, 2684.
 Beans, 5222; drilling of, 5223, varieties of, 5224; choice of, 5226; the best soils for, 5227; climate for, 5232; sowing, 5233; dibbling, 5237; after culture of, 5240; reaping, 5244; stacking, 5247; threshing, 5248; produce of, 5249; application of, 5251; diseases of, 5255.
 Beans, insects injurious to, 7666.
 Beasts of labour, 2014.
Beatson's contrivance for preventing ruts in roads, 3746.
Beatson, Major-General Alexander, his work on agriculture, page 1213. A. D. 1820; new theory of roads, 3695.
Bcaunié, Antoine, his work on agriculture, page 1216. A. D. 1770.
 Bed of a river, &c., 4420.
Beddoes, Thomas, M.D., his works on agriculture, page 1212. A. D. 1808.
 Bedford House of Industry, 7784.
 Bedfordshire, statistics of, 7784.
 Bee, the common, 7602; feeding, 7608; swarming, 7610; suffocating, 7614; produce and profit, 7615.
 Bees in Perthshire, 7849; in the 16th century, 248; of Galloway, 7840; rearing of, in Hungary, 631; in Poland, 655.
Belair, A. P. Julienne de, his work on agriculture, page 1217. A. D. 1794.
Belgrove, William, his work on agriculture, page 1223. A. D. 1755.
Bell, Benjamin, F.R.S.E., his work on agriculture, page 1212. A. D. 1802.
 Bell's reaping machine, 2737.
 Bend, a, 4417.
 Bends for ship-timber, mode of pruning, for producing, 4000.
Benetti, Santo, his work on agriculture, page 1222. A. D. 1810.
 Benin, description of, 1106.
 Benzoin, 1484.
 Berkshire, statistics of, 7790.
 Berry of plants, 1355.
Berry, the Rev. Henry, his opinion on the choice of live stock for breeding and feeding, 4851; his work on agriculture, page 1214. A. D. 1830.
Berthelot, his work on agriculture, page 1216. A. D. 1782.
Bertrand, Elie, his works on agriculture, page 1215. A. D. 1764.
Bertrand, his work on agriculture, page 1217. A. D. 1794; his work on agriculture, page 1221. A. D. 1780.
Bertrand, Jean, his work on agriculture, page 1215. A. D. 1764.
Bertochus, Dionysius, his work on agriculture, page 1221. A. D. 1496.
 Berwickshire, statistics of, 7835.
 Besoms used in farming, 2468.
 Betel leaf of Sumatra, 1024.
Bexon, Gabriel Leopold Charles Ame, his works on agriculture, page 1216. A. D. 1773.
 Bibliography, agricultural, of North America, 7908.
 Bibliography of British agriculture, 7898; of French agriculture, 7900; of German agriculture, 7901; of Italian agriculture, 7902.
Bidet, M., his work on agriculture, page 1221. A. D. 1778.
 Billington's opinion on pruning, 3990.
 Binot, the, 2620.
 Birch wine, 7799.
 Birds, foreign aquatic, 7567; gallinaceous, (see cock and hen), 7439; injurious to agriculture, 7639; of luxury which are or may be cultivated by farmers, 7531; singing, 7563; breeding and rearing, 7565.
Birkbeck, Morris, Esq., his works on agriculture, page 1213. A. D. 1815.
 Birnan empire, climate of the, 934; seasons of the, 935; soil of the, 936; cattle of the, 937; plants and trees, 938; animals of the, 939.
Biroli, Giovanni, his works on agriculture, page 1221. A. D. 1807.
 Bitter principle, the, in vegetables, 1421.
Bixa Orellana, 1230.
Bizhaub, his work on agriculture, page 1219. A. D. 1786.
Black, James, his work on agriculture, page 1209. A. D. 1777.
Blackwell, Alexander, M. D., his work on agriculture, page 1208. A. D. 1741.
Blaikie, Francis, his works on agriculture, page 1213. A. D. 1819.
 Blair Drummond, the moss of, 2183; the water wheel at, 2187.
 Blanks in plantations, filling up, 3983.
Blavet, his work on agriculture, page 1215. A. D. 1755.
 Bleaching flax, 5904.
 Blight, the, 1687; from cold and frosty winds, 1688; from sultry and pestilential vapour, 1689; from want of nourishment, 1690; originating in Fungi, 1691.
Blith, Walter, his works on agriculture, page 1207. A. D. 1649.
 Blood, as a manure, 2252.
 Bloom, 1470.
 Blubber, as a manure, 2247.
 Blues, vegetable, the finest of, for dyeing, 1415.
Blythe's Improver improved, 251.
 Board of Agriculture, the, 7915.
 Bogs, drainage of, 4234; improvement of, 4547; meadows, 5787; making the hay of, 5804; of Ireland, examination of the, 820.
 Boilers, 2806.
 Boiling machines, 2806.
 Bolting-machine, a hand, 2552.
Bonafous, M. Mathieu, his work on agriculture, page 1222. A. D. 1827.
 Bone-ashes as a manure, 2303.
 Bone-breaking machine, 2554.
 Bones of animals, 1881; increase in size of the, 1884; reproduction of the, 1886; articulation of the, 1888; as a manure, 2248.
 Bone manure, 4979.
Bonnemain, his work on agriculture, page 1218. A. D. 1816.
 Book farmers, p. 1177.
 Book-keeping, farm, Trotter's method of, 4885.
 Books on agriculture, Spanish and Portuguese, 7904; Flemish and Dutch, 7905; Swedish and Danish, 7906; Polish and Russian, 7907; American, 7908.
 Bootan, climate of, 1014; surface of, 1015.
 Boots worn in irrigation, 4403.
Borcke, H. A. Grafen, his work on agriculture, page 1219. A. D. 1779.
Bordley, J. B., his work on agriculture, page 1223. A. D. 1801.
 Borer, use of the, in well-digging, 4482.
 Boring instruments, Good's improved, 2507.
 Boring the earth for spring water, 4485; operation of, 4486.
 Boring trees, 1674.
 Borneo, agriculture of, 1028.
Bornot, M. A., his work on agriculture, page 1218. A. D. 1817.
Borro, Alessandro del, his work on agriculture, page 1221. A. D. 1718.
Bosc, K. Ad. H. von., his work on agriculture, page 1220. A. D. 1792.
Bosc, Th., his works on agriculture, page 1218. A. D. 1823.
Böstrichus pinipérdus, 537.
Boswell, George, his work on agriculture, page 1209. A. D. 1780.
Boucher d'Argis, Antonine Gaspard, his work on agriculture, page 1215. A. D. 1749.
 Bourbon, Isle of, 1143.
Bouthier, his work on agriculture, page 1216. A. D. 1780.
Boyce's first attempt at a reaping machine, 2732.
Boys, John, his work on agriculture, page 1211. A. D. 1796.
Bradley, Richard, F.R.S., his works on agriculture, page 1207. A. D. 1721.
 Brain, the, 1913; functions of the, 1915.
 Brake, the common, 2700; Wilkie's parallel adjusting, 2656.
 Branches of a plant, 1309; of trees, anomalies in the, 1601.
 Brazil, description of, 1232; vegetable productions of, 1233; live stock of, 1238.
 Bread-corn, the, of temperate climates, 1784.
 Breast-plough, used in irrigation, 4394.
 Breed, when improved, 2040.
 Breed of animals, improvement of a, 2023.
 Breeding, choice of live stock for the purpose of, 4835.
 Bridekirk, plan of the village of, 3850.
 Bridges, 3110; on roads, 3611.
 Bridge, portable, for passing sheep over marsh ditches, 7781.
 Bridgewater, Duke of, the father of canals in England, 3804.
 Britain, agriculture of, benefited by the revolution, 763; progress in the agriculture of, from the revo-

- lation to the middle of the eighteenth century, 773; improvement in the agriculture of, since the American war, 774; severe shock sustained by the agriculture of, 775; improvements in the agriculture of, during the eighteenth century, 799; agriculture of, during the middle ages, 195; classification of the agriculture of, 1280; introduction of agriculture into, 176; the chief mineral substances of, 3854; the climate of, 2437; deterioration of the, 2439.
- Broadcast sowing, 3149.
- Brodigan*, Thomas, Esq., his work on agriculture, page 1214. A. D. 1830.
- Bromelia Pinguin*, 1221.
- Broom, the common, 5633.
- Broom flax, 5994.
- Broom rape of the Flemish farmers, 470.
- Broussonnet*, Pierre Marie Auguste, his works on agriculture, page 1216. A. D. 1787.
- Brown*, Lieutenant, his system of paving roads, 3722.
- Brown*, Robert, Esq., his works on agriculture, page 1211. A. D. 1799.
- Brown's* vegetable for dyeing, 1418.
- Brugnone*, Gio., his works on agriculture, page 1221. A. D. 1781.
- Buchanan*, George, his work on agriculture, page 1213. A. D. 1825.
- Buch'ox*, Pierre Joseph, his works on agriculture, page 1215. A. D. 1760.
- Buckets, Chinese, for raising water, 995.
- Buckinghamshire, statistics of, 7783.
- Buck-wheat, 5188, 6111; species of, in cultivation, 6112; culture of, 6113; sowing, 6114; harvesting, 6115; produce of, 6116; use of, 6117; as a seed crop, 6122.
- Buds of plants, 1360; anomalies in the, 1603; regeneration of, when injured, 1680.
- Buffalo, the, 6973; breeding, rearing, and general management of, 6976; of Egypt, 1085.
- Buildings, agricultural, materials, and construction of, by Waistell, 2943; to delineate, 3364.
- Buildings, good, policy of erecting for the labouring classes, 7852.
- Bulbs of plants, 1313. 1361.
- Bull, see horned cattle, 6773.
- Bulliard*, his work on agriculture page 1216. A. D. 1778.
- Bunias, the oriental, 5641.
- Burges's* improvement in the construction of axles, 2751.
- Burnet, the, 5619
- Burning clay, 3223; an improved method of, 3225; by lime without fuel, 3227; use of pyrites in, 3228.
- Burning out grain, 3203.
- Burning lands, 3209. 4536.
- Burroughs*, Edward, Esq., his work on agriculture, page 1213. A. D. 1820.
- Busby's* borer for quicksand, 2518.
- Buschire and its territory, 864.
- Bustard, the, 7522; species of, 7523.
- Buteshire, statistics of, 7859.
- Butter of cacao, 1448; of cocoa, 1449; of nutmeg, 1450.
- Butter tree, the, 1110.
- C.
- Cabbage, 5497; culture of, 5493; varieties of, 5499; soil for, 5502; planting, 5503; after-culture of, 5505; application of, 5506; saving the seed of, 5509; diseases of, 5510.
- Cabbages and other esculent vegetables, insects injurious to, 7679.
- Cabbage tree, 1056.
- Cadet de Vaur*, Antoine Alexis, his works on agriculture, page 1216. A. D. 1782.
- Caithness, statistics of, 7855.
- Cale's*, M. V. M., M. D. his work on agriculture, 7905.
- Calf, see horned cattle, 6773.
- Calf-pens, 2835; in Gloucestershire, 2836.
- Callipers, Broad's, for measuring standing timber, 4075.
- Calthorpe*, Charles, his work on agriculture, page 1207. A. D. 1635.
- Calvel*, Etienne, his work on agriculture, page 1218. A. D. 1809.
- Cambodia, agriculture of, 953.
- Cambridgeshire, statistics of, 7786.
- Camel and dromedary in Egypt, 1088.
- Camel of Persia, 872.
- Camel, the, 7385; in Hindostan, 917.
- Camelopard, the, 7388.
- Camphire, preparation of, 979.
- Camphor, 1489.
- Campo Morto, account of the farm of, in the Maremmas, 303.
- Canada, climate and surface of, 1192; soil of, 1193; products of, 1194.
- Canal bill, the principal heads of a, 3813.
- Canals, 3798; Dr. Smith's opinion of, 3799; general arguments in favour of, 3800; the great advantages of, 3801; first made in Egypt, 3802; rise of, in Britain, 3804.
- Canal, the first step towards forming a, 3806; estimating the expense of, 3811; powers granted by government in the forming of a, 3812; execution of a, 3817.
- Canary grass, 5169; culture of, 5170; reaping of, 5171; common produce of, 5172; use of the seed of, 5173.
- Canary Islands, the, 1146.
- Canciana*, his work on agriculture, page 1221. A. D. 1776.
- Cantuni*, Carlo Antonio, his work on Agriculture, page 1221. A. D. 1778.
- Caoutchouc, 1490.
- Cape Breton, Island of, 1196.
- Cape of Good Hope, climate of the, 1114; surface of the, 1115; soils of the, 1116; landed property in the, 1117; farms of the, 1118; agricultural products of the, 1119; live stock of the, 1125; agricultural implements and operations of the, 1132; tribes in the interior of the, 1134.
- Capital required by the farmer, 4820.
- Capsule, valves of the, in plants, 1350.
- Caraway, 6068; culture and management of, 6069; produce of, 6070; uses of, 6071; substitutes for, 6073.
- Carbon, as a vegetable aliment, 1536; emitted by the skin of animals, 1878; in animals, 1918.
- Carcass of cattle and sheep, the chief object, 2031.
- Carlow, statistics of, 7871.
- Caronelli*, Pietro, his works on agriculture, page 1221. A. D. 1791.
- Carradori*, Gioachino, his work on agriculture, page 1221. A. D. 1803.
- Carrera*, Antonio, his work on agriculture, page 1221. A. D. 1780.
- Carrots, 5443; varieties of, 5444; soil for, 5445; climate for, 5448; manure for, 5449; sowing, 5452; after culture of, 5458; taking up, 5461; storing, 5463; produce of, 5464; uses of, 5465; saving the seed of, 5469; diseases of, 5470.
- Carrying, 3115.
- Carp, 7573; raising, 7574.
- Carpenter's* work-room on a large farm, 2869.
- Carse lands of Stirlingshire, 7814.
- Carter*, Landon, his work on agriculture, page 1223. A. D. 1789.
- Carthage, agriculture of, 38.
- Carthamus tinctorius*, 1083.
- Cartilage of the bones of animals, 1887.
- Cart, market, of Poland, 652; improved Russian, 683.
- Cart, the, of Hindostan, 920; the Scotch one-horse coup, 2752; the Scotch corn, 2753; the Scotch two-horse, 2754; the corn, 2756; the improved quarry, 2761; the three-wheeled, 2762; of Thesaly, 757.
- Carts, 2744; improved two-horse, 2755.
- Cart-sheds, 2865.
- Carts, three-wheeled, used in irrigation, 4400.
- Carver*, Jonathan, Esq., his work on agriculture, page 1223. A. D. 1779.
- Castelli*, Benedict, his work on agriculture, page 1221. A. D. 1628.
- Castellet*, Constans, his work on agriculture, page 1221. A. D. 1778.
- Casualties of life, security against, 7967.
- Cat, the, 7424; the genet, 7427.
- Catch drain, a, 4419.
- Catch-work watering, an example of, 4411.
- Catechu, extract of, 1409.
- Cattaneo*, Giacomo, his work on agriculture, page 1221. A. D. 1767.
- Cattle-hammels, 2831.
- Cattle, in Elizabeth's reign, 224; of Scotland in 1598, 228; the Hebridean breed of, 7859.
- Cattle-sheds, 2830.
- Cattle-stock account, form of a, 4899.
- Cattle-weighing machine, 2567.
- Caudex of plants, 1364; structure of the, 1365, 1366.
- Causeways, 3696.

- Cavan, statistics of, 7887.
 Cayenne, or French Guiana, agriculture of, 1240.
 Celebesian Islands, agriculture of the, 1031.
 Cels, Jacques Martin, his works on agriculture, page 1217. A. D. 1795.
 Cementation, the mode of adhesion by, in animals, 1897.
 Ceylon, climate of, 927; soil of, 928; cultivation in the interior of, 929; agricultural implements of, 930; a farm-yard in, 931.
 Chabert, Philippe, his works on agriculture, page 1216. A. D. 1785.
 Chabonillé, Dupetitmont, M., his work on agriculture, page 1219. A. D. 1825.
 Chaff-cutter, 2560.
 Chambray, Louis, his work on agriculture, page 1215. A. D. 1765.
 Chamomile, culture of, 6181.
 Changes in the animal economy, 2055.
 Channel for a river, to cut a new, 4873.
 Chanvallon, his work on agriculture, page 1216. A. D. 1769.
 Chaptal, Comte, his work on agriculture, page 1218. A. D. 1823.
 Charcoal, 1493; properties of, 1494.
 Chariot, the, of the Flemish farmer, 514.
 Charm drawn by the Singalese on their threshing-floor, 930.
 Charring wood, 4066.
 Chatelain, le Chevalier, his work on agriculture, page 1218. A. D. 1816.
 Cheesc, Parmesan, 270.
 Cheese-making, in Cheshire, 7814.
 Chelsey farm, 7790.
 Cherry, as an orchard fruit, 4101.
 Cheshire, statistics of, 7814.
 Chestnut, Spanish, 4102.
 Chiceory, 5514; culture of, 5515. 6162; value of, as a coffee plant, 6164; as a salad plant, 6165.
 Chick pea, the, 5286.
 Chilblains in plants, 1703.
 Chile, agriculture of, 1229; plants of, 1230.
 China, its canals, 3803; state of agriculture in, 960; Dr. Abel's opinion respecting cultivation in, 961; Livingstone's observations on agriculture in, 961; climate of, 963; surface of, 964; soil of, 965; landed property in, 966; agricultural products of, 967; tea districts of, 968; culture of the tea plant in, 969; the white cabbage of, 988; edible and useful vegetables, 989; live stock of, 990; wild animals of, 992; birds of, 993; fisheries, implements, and operations of agriculture in, 995, 996; manures of, 999; terrace cultivation in, 1009; forests of, 1011; natural agricultural fête of, 1012.
 Chocolate plant, the, 1231.
 Christ, J. L., his work on agriculture, page 1219. A. D. 1780.
 Cider, when best for bottling, 4133.
 Cider, manufacture of, 4122; produce of, by the acre, 4137.
 Cider casks, the best, 4149.
 Cider cloths, 4147.
 Cider-making in Gloucestershire, 7791; machinery and utensils necessary for, 4138.
 Cider-mill, Devonshire, figured and described, 4140; of the south of France, 4143; for a private family, 4144.
 Cider-press of Herefordshire, 4146.
 Cider-presses made from the small-leaved lime, 7791.
 Cider-vat, 4148.
 Cisterns for urine, used in Flemish farmery, 441.
 Cistus ladaniferus, 731.
 Civilisation, as influencing agriculture, 1271; influence of, in increasing the number of plants in a country, 1770.
 Clackmannanshire, statistics of, 7846.
 Clare, statistics of, 7880.
 Claridge, John, his work on agriculture, page 1208. A. D. 1744.
 Clark, John, F. S. A., his works on agriculture, page 1210. A. D. 1794.
 Clarke, Cuthbert, his work on agriculture, page 1209. A. D. 1777.
 Clarke's opinion on draining roads, 3615.
 Claws of animals, 1864.
 Clay, burnt, action of, on the soil, 3220; application of, as a manure, 3229; drying and burning, for manure, 3219.
 Cleaning cattle, 3233.
 Cleaning roots, &c., 3137.
 Cleanliness, essential to the health of animals, 2080.
 Cleghorn, James, Esq., his work on agriculture, page 1213. A. D. 1822.
 Clergy, the Norman, fond of agriculture, 205.
 Climate, as influencing agriculture, 1248; in respect to farming lands, 4718; of the British Isles, 2437; deterioration of the, 2439.
 Clipping plants, 3155.
 Cliquot, Blervache, his work on agriculture, page 1216. A. D. 1789.
 Clozen, Baron de, his work on agriculture, page 1220. A. D. 1826.
 Cloud-berry, use of the, 701.
 Clouds, 2356; simple modifications of, 2357; intermediate modifications of, 2358; compound modifications of, 2359.
 Clover, insects injurious to, 7675.
 Clover, introduction of, 235.
 Clover, 5521; the red, 5522; the white, 5524; the yellow, 5525; the flesh-coloured, 5527; soil for, 5530; climate for, 5531; sowing, 5533; after culture of, 5540; taking the crop of, 5541; soiling, 5542; nutritive products of, 5565; saving the seed of, 5566; threshing, 5569; produce in seed, 5572; diseases of, 5573.
 Clover-hay, mode of making, 5545; produce of, 5563; value of, 5564.
 Clydesdale, see Lanarkshire, 7842.
 Coal, 3855; indications of, 3856; discovery of, 3857.
 Coal fields of Britain, 3858.
 Cochin-China, agriculture of, 954.
 Cochineal, the Mexican, 1189.
 Cochrane, Archibald, Earl of Dundonald, his works on agriculture, page 1210. A. D. 1795.
 Cock and hen, the Bankiva, 7439; the jungle, 7439; the common dunghill, 7441; the game, 7442; the Dorking, 7443; the Poland, 7444; the every day, 7445; the bantam, 7446; the Chittagong, or Malay, 7447; the shack-bag, or Duke of Leeds's, 7448; the improved Spanish, 7449; breeding, 7450; health, 7451; moulting, 7458; hatching, 7460; hatching by artificial heat, 7463; incubation of chickens by hot water, 7464; products, 7467; eggs, 7468; feathers or down, 7470; feeding and fattening the carcass, 7473; feeding-houses, 7474; fattening younger chickens, 7477; choice of full-sized fowls for feeding, 7478; cramming, 7480; the Oakingham method of feeding, 7482; castration, 7484; pinioning, 7485; diseases of, 7524.
 Cockburn, John, notice of, 792.
 Cockchafer, the, 7676.
 Cock-roach, the, 7690.
 Cocoa-nut tree, description of the, 901.
 Cod-fishery, 3877.
 Coffee-tree, the, 1215; cultivating the, 1216.
 Coitevaux, François, his works on agriculture, page 1217. A. D. 1792.
 Coke oven and lime-kiln, Heathorn's, 628.
 Cold, influence of, on the vital principle of plants, 1664; most hurtful in hollow places, 2319; greatly excluded by a slight covering, 2321.
 Coldingen, near Hanover, farm of, 599.
 Colerus, J., his works on agriculture, page 1219. A. D. 1591.
 Collyns, W., Esq., his work on agriculture, page 1214. A. D. 1826.
 Colmata, the Italian process of flooding lands, 2208.
 Colombia, description of, 1241.
 Colouring matter, the, in vegetables, 1414.
 Comber, Thomas, LL. D., his works on agriculture, page 1209. A. D. 1770.
 Comfort, necessary for domestic animals, 2081.
 Comfrey, the rough, 5516.
 Commercial and Agricultural Magazine, Anon. page 1211. A. D. 1799—1815.
 Commonable lands, 3476; general principles of appropriating, 3490.
 Communications to the Board of Agriculture, Anon. page 1211. A. D. 1797—1819.
 Comparetti, his work on agriculture, page 1221. A. D. 1798.
 Complete farmer, &c. &c. Anon. page 1208. A. D. 1766.
 Composts and other manures, 4976.
 Conduct and economy of an agriculturist's life, 7952.
 Congo, 1108; useful plants of, 1110; live stock of, 1112.
 Consolidating of landed property, 3471.
 Consolidation of soils, 2172.
 Constantia wine, the, 1121.
 Consumption in plants, 1714.
 Continents, temperature of, 2353.
 Contortion in plants, 1712.
 Conveniences of farm-houses and detached offices, as arranged by Waistell, 2923.

- Convexity, degree of, proper for roads, 3675.
 Copaiva, balsam of, 1462.
 Copal, 1467.
Copineau, Abbé, his work on agriculture, page 1216. A. D. 1780.
 Copse-woods, improvement of, 4026; products of, 4043.
 Corals and corallines, as a manure, 2253.
 Coriander, 6065; culture and management of, 6066; produce and use of, 6067; substitutes for, 6073.
 Corium of animals, 1847.
 Cork, 1491.
 Cork Institution, the, 7922.
 Cork, statistics of, 7877.
 Cork tree, the, in Spain, 747.
 Corn, early exportation of, 240.
 Corn, whether it ought to be sown broadcast or in drills, 4989; preservation of, after being threshed, 4989.
 Corn-barn, 2847; the English, 2848.
 Corn-bin, the, 2530.
 Corn-bruising machine, 2558.
 Corn crops cultivated in Britain, 4982.
 Corn drill, Cooke's three-row, 2681.
 Corn farmers, 7738.
 Corn, frosted, 4996.
 Corn-laws, the, 765.
 Corn-measures, 2533.
 Corn-rake, the, 2451; of East Lothian, 2452.
 Corn-sacks, 2534.
 Corn-screen, the, 2524.
 Corn-stacks of the square sort, proper sizes of, 3277.
 Corn-stands, 2908.
 Cornwall, statistics of, 7825.
Costa, Ch., his work on agriculture, page 1220. A. D. 1802.
 Cottage, a double, for two married ploughmen, 4180; a double, of only one floor, 4178; on a smaller scale, 4179; a good mechanic's, 4182; a labourer's, with cow-house and piggery, 4181.
 Cottage cow, the best modes of keeping a, 3846.
 Cottage farmers, 7726.
 Cottage fit for a tradesman, mechanic, or bailiff, 4177.
 Cottages, establishment of, 3845.
 Cottages for labourers, 2876—2900; in Dumfriesshire, 7839; in the Hebrides, 7859; in Staffordshire, 7796; in West Lothian, 7845; of Kincardineshire, 7851; of Moldavia and Wallachia, 760; ornamental, 2897—2900; picturesque, 4183.
Cotte, L., his works on agriculture, page 1217. A. D. 1790.
 Cotton plant, culture of, in Jamaica, 1213; in Sicily, 318.
 Cotton trees in China, 983.
 Cottons of Sumatra, 1026.
 Cotyledon of plants, 1347.
 Court farmer, 7723.
 Covenants of leases, 4688.
Coventry, Andrew, M.D., his works on agriculture, page 1212. A. D. 1808.
Coventry, Dr., 7847.
 Cow, see horned cattle, 6773.
 Cow cabbage, the, 5500.
 Cowhouse, *Harley's*, 2832.
 Cows, breeding of, on the farm at Moegelin, 587.
 Cowshed, Cornish, 7825.
 Cradle-scythe, 2480.
Cramer, John Andrew, his work on agriculture, page 1219. A. D. 1766.
 Craw, the, 7616.
 Crawfish, the, 3904.
 Crayfish, or more properly crawfish, 7616.
 Crescent used in irrigation, 4396.
Crescentius, his works on agriculture, page 1221. A. D. 1471.
 Cress, garden, 6159; soil for, 6160; use of, 6161.
 Cribs for cattle used in Derbyshire, 7799.
 Cromarty, statistics of, 7854.
 Crops, importance of a judicious rotation of, 4912. 4927; rotation of, 2217; rationale of, 2218; *Gri-senthwaite's* theory of, 2220; the principles of, 2221; influence of, in destroying insects, 2223.
 Cross-breed, when advantageous, 2062.
 Cross-cutting machine, *Brown's*, 2715.
 Cross moss-cutting machine, used at Mount Annan, in Dumfriesshire, 7839.
 Crossing, the good effects of, 2053; the bad effects of, 2054. 2056.
 Crossing, vegetable, 1632; anomalous effect of, 1635.
 Crossings of roads should be at right angles, 3558.
 Croton, a species of, in Brazil, used as tea, 1237.
Crud, Le Baron E. V. B., his work on agriculture, page 1218. A. D. 1820.
Cruikshank's opinion on pruning, 3989.
 Crust of our earth, the, 2101.
 Crusts of animals, 1872.
 Cryptogamia, favourite habitations of, 1734.
 Cuba, agriculture of, 1198.
Culley, Messrs. Matthew and George, pupils of *Bakewell*, 789.
Culley, George, his works on agriculture, page 1210. A. D. 1786.
 Cultivator, *Bartlett's*, 2710; *Wilkie's* parallel adjusting, 2556; *Finlayson's* self-cleaning, 2657; *Weir's* improved, 2653; the Scotch, 2659; *Parkinson's* 2660; *Hayward's*, 2662; *Beatson's*, 2663.
 Culture, effect of, on woody plants, 3970; on the ligneous plants in common use in planting and gardening, 3971; in the north and in the south of Europe, characteristics of, 1251; the general effect of, on plants, 1766; influence of, on fruits, 1768; influence of, on plants of ornament, 1769.
 Culture of plants, the greatest refinement in, 1771.
 Cumberland, statistics of, 7810.
Cumming's opinion respecting the form of wheels proper for roads, 3734.
 Curassow, the crested, 7496.
Curculio palmærum, the, of Surinam, eaten as a luxury, 1243.
 Currant, as an orchard fruit, 4104.
Curtis, William, his work on agriculture, page 1210; A. D. 1789.
Curwen, John Christian, M.P., his works on agriculture, page 1212. A. D. 1809.
Cuscuta europæa, 1759.
 Cuticle of animals, 1845.
 Cutting over old hedges, 2988. 3021.
 Cutting plants, 3151.
 Cutting trees, the best mode of, 4046.

D.

- Dairy, the, and its management, 6976; operations of, 6977.
 Milk, 6978; butter, 6979; cheese, 6980; whey, 6981; constituent parts of milk, cow's milk, 6983; ass's milk, 6984; ewe's milk, 6985; goat's milk, 6986; mare's milk, 6987; camel's milk, 6988; sow's milk, 6989; use of these milks, 6990; lactometers, 6991.
 The dairy-house for general purposes, 6992; properties requisite in a good milk-house, 6993; a butter dairy, 6994; cheese dairy, 6995; dairy for private use, 6996; dairies for dairy farmers, 6997; utensils of the dairy, 7007.
 Milking, 7014; management of milk, 7017.
 Making and curing of butter, 7019; the making up, 7025; the salting or curing, 7027.
 Cheese-making, 7039; rennet, and its uses, 7041; colouring matter, 7047; setting the curd, 7050; management in the press, 7054; management in the cheese-room, 7056.
 Catalogue of the different sorts of cheeses, and other preparations made from milk, 1045; British cheeses, 7059; foreign cheeses, 7090; preparations of milk, 7097.
 Dairy farmers, 7733.
 Dairy at Woburn, 7784.
 Dairies of Ireland, 841.
 Daisy-rake, the, 2454.
Dalrymple, William, Esq., his work on agriculture, page 1211. A. D. 1800.
Dandolo, Vincenzo, his works on agriculture, page 1222. A. D. 1812.
 Dartmoor, depôt for prisoners of war at, 7824.
Darwin, Erasmus, M.D. F.R.S., his work on agriculture, page 1211. A. D. 1800.
 Date tree, the, in India, 907; of Persia, 868.
Daubenton, Jean Louis Marie, his work on agriculture, page 1217. A. D. 1802.
Davey, John, Esq., his work on agriculture, page 1214. A. D. 1830.
Davies, Walter, A. M., his work on agriculture, page 1212. A. D. 1810.
Davis, Thomas, Esq., his work on agriculture, page 1210. A. D. 1794.
Davy, Sir Humphry, his work on agriculture, page 1213. A. D. 1813; his opinion as to the application of farm-yard manure, 2239; result of his dis-

- cussion on the effects of saline substances on vegetation, 2311; his table of the nutritive products of, 5000.
- Davy*, Sir H., table of the nutritive products of the principal herbage plants, 5520; table of the nutritive products of grasses, 5668.
- Dawson*, an improver of Scottish agriculture, 796; his opinion of lime as a manure, 4975.
- Day lily, the, 5517.
- Day's work of a farm labourer, 4904.
- Dealings, commercial, of the agriculturist, 3384.
- Dean*, Dr., his work on agriculture, page 1223. A. D. 1790.
- De Chabrol de Volvic*, Comte, his work on agriculture, page 1219. A. D. 1825.
- Decortication of trees, 1682.
- Deer, the, 7369.
- Deer husbandry, 7373.
- Deer in Wimpole Park, 7786.
- Delabergerie*, J. B. R., his work on agriculture, page 1218. A. D. 1815.
- Delpierre*, Léocade, his work on agriculture page 1219. A. D. 1826—1828.
- Dendrometer, Rogers's, for measuring standing timber, 4076; Gorrie's, 4075; Monteith's, 4075.
- Denmark, commencement of agricultural improvement in, 562; farm-houses of, 563; the farmer's family in, 564.
- Deposits, alluvial, 2105.
- Depradt*, D., his works on agriculture, page 1218. A. D. 1803.
- Der Schweizer*, his work on agriculture, page 1219. A. D. 1760.
- Derbyshire, statistics of, 7799.
- Dériéule*, his work on agriculture, page 1219. A. D. 1766.
- Desbois*, Francis Alexander Aubert de la Chesnaie, his work on agriculture, page 1215. A. D. 1751.
- Deslandes*, his work on agriculture, page 1218. A. D. 1820.
- Desplaces*, Laurent Benoist, his works on agriculture, page 1215. A. D. 1762.
- Despomniers*, his work on agriculture, page 1215. A. D. 1762.
- Destère* his work on agriculture, page 1223. A. D. 1800.
- Development of vegetables, process of the, 1565.
- Devonshire, plan of a new village sea-port in, 3852; statistics of, 7824.
- Dew, 2364; phenomena of, 2365; cause of, 2366.
- Deyeux*, and others, their work on agriculture, page 1216. A. D. 1782.
- Dibber, the common, 2471.
- Dibblers, frame of, used in Sweden, 703.
- Dibbling machine, Coggin's, 2473. 2577; the horse, 2686; the bean or potato, 2574.
- Dibbling wheat, 5034.
- Dickson*, Adam, his works on agriculture, page 1208. A. D. 1762.
- Dickson*, R. W., M. D., his works on agriculture, page 1212. A. D. 1804; and page 1211. A. D. 1799—1815.
- Dicotyledonæ, distribution of, 1780.
- Digging, 3123.
- Digging up crops, 3182.
- Dirom*, Gen., commenced the village of Bridckirk, 3850.
- Dirt-eating, among the West Indians, 1224.
- Diseases of animals, 1991.
- Diseases of plants, 1685.
- Distribution, general, of plants, 1722; physical, 1724; effects of temperature on the, 1725.
- Distribution, local, of animals, 2005; effect of temperature on, 2006; effect of situation on, 2009; effect of the rapacity of carnivorous animals on, 2010; effect of man on, 2011.
- Distribution of animals on the face of the globe, 1999.
- Ditch, the simple, 2967; the double, 2960.
- Ditch fences, 2965.
- Ditch and hedge, the double, 2971.
- Division of lands, 3307.
- Dix*, William Spier, his work on agriculture, page 1211. A. D. 1797.
- Dodson*, Col. William, his work on agriculture, page 1207. A. D. 1665.
- Dog, the, 7391; the shepherd's, 7393; English sheep, 7394; Scotch sheep, 7395; the mastiff or guard, 7396; the bull dog, 7397; the terrier, 7398; the pointer, setter, and spaniel, 7399; breeding and rearing, 7402; diseases, 7403.
- Dombasle*, C. J. A., Mathieu de, his works on agriculture, page 1218. A. D. 1824—1830.
- Donaldson*, James, his works on agriculture, page 1207. 1210. A. D. 1697 and 1794.
- Donegal, statistics of, 7891.
- Doria*, Luigi, his work on agriculture, page 1221. A. D. 1798.
- Dormouse, the fat, 7368.
- Dorsetshire, statistics of, 7819.
- Dossie*, Robert, Esq., his work on agriculture, page 1209. A. D. 1768.
- Double-dibber, 2472.
- Douette-Richardot*, Nicolas, his work on agriculture, page 1218. A. D. 1825.
- Douglas*, Robert, D. D., his work on agriculture, page 1211. A. D. 1798.
- Dourchez*, Charles, his works on agriculture, page 1218. A. D. 1803.
- Down, statistics of, 7894.
- Downs, 4563; sandy, on the sea-shore, improvement of, 4564.
- Doxat's* machine for assisting human power, 2580.
- Doyle*, Martin, his work on agriculture, page 1214. A. D. 1829.
- Draftsman, agricultural, 7756.
- Drag for two-wheeled carriages, Kneebone's, 2760.
- Drag-cart, Lord Somerville's, 2757.
- Dragging out dung or earth, 3129.
- Dragon's blood, 1463.
- Drain of conveyance, the, 4283; of collection, 4284; the boxed and rubble, 4285; the brick, 4286; the gravel or cinder, 4288; the wood, 4289; the spray, 4290; the straw, 4291; the turf, 4292; the wedge or triangular sod, 4293; the hollow furrow, 4294; the earth, 4295; the pipe of turf, 4296; the mole, 4299; the wheel, 4300.
- Drainage of the estate of Spottiswoode, in Berwickshire, 4255; of roads, 3602; Paterson's, 3604; of wet or boggy grounds, 4234; of mixed soils, 4250.
- Draining, the implements for, 4307.
- Draining mines, quarries, pits, ponds, and lakes, 4273—4277.
- Draining-spades, 4311.
- Draining, 4213; theory of, 4214.
- Draining retentive soils, 4267.
- Draining-scoop, the, 4308.
- Draining-shovel, the, 4309.
- Draining sod-knife, 4310.
- Drains, formation of, 4278; the different sorts of, 4282; the best season for making, 4303; the duration of, 4304; the expense of, 4305; the enemies of, 4306.
- Drain sluice, a, 4409.
- Dralet*, his work on agriculture, page 1217. A. D. 1801.
- Draught machine, 2563; More's, 2564; Braby's, 2565.
- Drawing, 3116.
- Drift-sands of the outer Hebrides, improvement of, 4565.
- Drill and horse hoe, Cooke's improved, 2679.
- Drill barrow, the common hand, 2575.
- Drill machines, the best, 2695.
- Drill rake, the, 2455.
- Drill roller, the, 2691; the Norfolk, 2713.
- Drills, turnip, 2687.
- Drill-watering machine, 2692; estimate of its operations, 2693; its construction, 2694.
- Drills for stirring the soil between the rows, 7792.
- Drill, the Norfolk, 2680; the block-plough, 2685.
- Drilling, 3266.
- Drilling wheat, 5032.
- Driver*, Abraham and William, their work on agriculture, page 1210. A. D. 1794.
- Driving carts and waggons, 3272.
- Droitwich salt works, 7792.
- Dromedary of Arabia, 887.
- Dropsy in plants, 1697; in succulent plants, 1698.
- Drupe of plants, 1354.
- Drying the bark of trees, 4051.
- Dublin, statistics of, 7864.
- Dublin Society, establishment of the, 813.
- Dublin Society, the, 7920.
- Dubois*, Louis, his work on agriculture, page 1218. A. D. 1824.
- Dubois*, J. B., his work on agriculture, page 1217. A. D. 1790.
- Dubrunfaut*, M., his work on agriculture, page 1218. A. D. 1825.
- Duck, the, 7498; varieties and species of, 7499; breeding, 7504; incubation of, 7505; fattening of, 7507; decoys for wild, 7508.
- Ducks of Buckinghamshire, 7783.
- Ducouédic*, his work on agriculture, page 1217. A. D. 1800.

- Dugdale*, William, his work on agriculture, page 1207. A. D. 1662.
- Dumfriesshire, statistics of, 7839.
- Dumont*, Coursset, his work on agriculture, page 1216. A. D. 1784.
- Dunbartonshire, statistics of, 7843.
- Dung, farm-yard, management of, 4959.
- Dung of birds, as a manure, 2257; of sea-birds, as a manure, 2258; of domestic fowls, as a manure, 2261; of cattle, as a manure, 2263; of sheep and deer, as a manure, 2264; of horses, as a manure, 2265; treatment of, 2266; of the street and road, as a manure, 2267; to preserve, 2278.
- Dung-drag, the, 2456.
- Dung-yard and pit, the, 2903.
- Dunrobin, mansion and park of, in Sutherland, 7856.
- Dupont*, his works on agriculture, page 1215. A. D. 1764.
- Duration of plants, anomalies in the, 1621.
- Durham, statistics of, 7808.
- Dutton*, Hely, Esq. his works on agriculture, page 1212. A. D. 1808.
- Duvergé*, his work on agriculture, page 1215. A. D. 1763.
- Dwelling-house of the farmer, 2870.
- Dyce*'s method of blasting granite rock, 4526.
- E.
- Earth, the, surface of, 2109.
- Earth's surface, nature of the, affecting plants, 1740.
- Earth-hack, the, 2457.
- Earths contained in plants, 1502. 1531; proportions of the, 1532.
- Earths, how produced, 2100; variously composed, 2110.
- East Lothian, statistics of, 7834.
- East Meath, statistics of, 7874.
- Eckhart*, J. Gli von, his work on agriculture, page 1219. A. D. 1754.
- Edge railways, on the middle or sides of public roads, 3797.
- Edgeworth*'s opinion on keeping a road in repair, 3759; on the breadth and strength of roads, 3597; road fences, 3617; on laying out roads, 3550; with respect to the preservation of roads, 3729.
- Edgeworth*, Richard Lovell, Esq., F. R. S. and M. R. I. A., his work on agriculture, page 1212. A. D. 1810.
- Education, improvement of agriculture by means of, 7931; of the poor, remarks on, 7824; professional, of agriculturists, 7942.
- Eel, 7585.
- Eels, fresh water, habits of, 7850.
- Eggs of birds, impregnation of the, 1975.
- Egypt, climate of, 1071; surface of, 1072; fertility of, 1073; limits of cultivated, 1074; landed property in, 1075; the cultivators of, 1076; agricultural products of, 1077; fruit trees of, 1083; live stock of, 1084; agricultural implements of, 1089; operations of agriculture in, 1090; soil of, 14.
- Elder tree, use of the, 4103.
- Electricity, the nature of, 2328; a profitable application of, 2329.
- Elemi, 1458.
- Elephant, the, in Hindostan, 916.
- Elevation, as influencing agriculture, 1260; effects of, on the habitation of plants, 1732; anomalies of, 1736; influence of, on plants in various ways, 1735; influence of, on aquatics, 1737.
- Elevation of lands relatively to farming, 4764.
- Elevations and depressions on paper, to protract, 3348.
- Elk, the, 7375.
- Elliot*, his work on agriculture, page 1223. A. D. 1764.
- Ellis*, William, his works on agriculture, page 1208. A. D. 1732.
- Elsner*, J. G., his work on agriculture, page 1220. A. D. 1829.
- Elstobb*, W., his work on agriculture, page 1210. A. D. 1793.
- Embanking origin of, 4320; theory of, 4323.
- Embankment, the earthen mound, 4340; the mound with puddle wall, 4346; the earthen wall, 4339; the oldest, in England, 4321.
- Embankments, first made, 239; for fixing drifting-sands, shells, or mud, 4353; in Cambridgeshire, 7786; in Lincolnshire, 7801; of Egypt, 12; of cast iron, 4357; of roads, 3611.
- Embryo of the seed of plants, 1346.
- Enclosures, size of, 5832.
- Engel*, Lud. Hen. Hs. von, his work on agriculture, page 1220. A. D. 1803.
- Engineers, agricultural, 7754.
- England, state of agriculture in, from the restoration to the middle of the 18th century, 776; in the beginning of the 18th century, 777.
- Epidéndrum flós àëris*, the, 1761.
- Epidermis of plants, structure of, 1369.
- Epsom water, 7778.
- Equisetaceæ, 1329.
- Ergot of rye, 5079.
- Eschenbach*, Ch. Ghld., his work on agriculture, page 1220. A. D. 1802.
- Escher*, von Berg, his work on agriculture, page 1220. A. D. 1808.
- Essai sur les Associations Agricoles. Anon. page 1219. A. D. 1826.
- Essex, statistics of, 7781.
- Estates have good and bad characters, 4668; immense, in Hungary and Austria, 620; landed, the laying out of, 3467; consolidation of, 3471; management of, 4624.
- Etienne*, Charles, and J. Liébault, their works on agriculture, page 1214. A. D. 1529.
- Etiolation in plants, 1706.
- Euphorbium, 1477.
- Europe, present state of agriculture in, 259.
- Evergreens, season for planting, according to Mr. M'Nab, page 1240.
- Excitability of plants, 1657.
- Exercise, moderate, necessary for domestic animals, 2078.
- Exotics, curious hot-house, of Britain, application of, 1820; native habitation of, 1821.
- Expenses, personal, of farmers, 4921.
- Experience, the foundation of all knowledge, 1825.
- Experiments, the Woburn, on the culture of grasses, 5717.
- Experiments, use of, in agriculture, 165.
- Extract, vegetable, as the food of plants, 1528; Saussure's experiment respecting, 1529.
- Extractive, in animals, 1942.
- Extracts, vegetable, 1408; utility of, 141.
- F.
- Fabbroni*, Adamo, his works on agriculture, page 1221. A. D. 1802.
- Fabre*, his work on agriculture, page 1217. A. D. 1800.
- Faggoting, 3206.
- Fairbairn*, John, his work on agriculture, page 1213. A. D. 1823.
- Falkland Islands, 1246.
- Fall*, Thomas, his work on agriculture, page 1214. A. D. 1829.
- Fallow deer, the, 7372.
- Fallowing lands, 4944; operation of, 4950; expense of, 4957; of soils, 2174; objections to, 2177; origin of, 217.
- Fallows, the working of, 4944.
- Fanaro*, Vincenzo, his work on agriculture, page 1221. A. D. 1658.
- Fanners, when first made in Roxburghshire, 7836.
- Farey*, John, sen., his work on agriculture, page 1212. A. D. 1811.
- Farey*'s opinion of the width of roads, 3596; on the size of wheels for roads, 3730; on the best forms of axles for roads, 3788.
- Farish*, John, his work on agriculture, page 1212. A. D. 1810.
- Farm, an arable, commodious arrangement for, 2955; the subdivisions of, 2962; a grazing in a mountainous country, Waistell's plan for, 2948; for a small arable and grazing, 2949.
- Farm, extent of land suitable for a, 4781; stocking a, 4826.
- Farm under mixed husbandry, Marshal's arrangement of, 2951.
- Farm, subsoil relatively to the choice of a, 4760.
- Farm bailiff, 7717.
- Farm buildings, the arrangement of a set of, 2919; in the colder latitudes of Europe and America, 2920; Waistell's form for, 2921; at Bromfield in Cheshire, 7814.
- Farm house and outbuildings of the largest dimensions, by Waistell, 2959.
- Farm house and offices, Beatson's arrangement of a small, 2952.
- Farm houses, Danish, 565.
- Farm houses, examples of, 2871—2874; in the Hebrides, 7859; on the Marquess of Stafford's estates in Shropshire, 7795.

- Farm labour, arrangement of, 4910; rules for the, 4913.
- Farm labourers, 7711.
- Farm lands, arrangement of, 4186; example of laying out, from a newly inclosed common, 4204; improvements of, 4571; sheltering, 4584; the moral and intellectual means of improving, 4604.
- Farm road, 3594.
- Farm stables in Scotland, 2821.
- Farms, the proper size of, 4151; enlargement or diminution of, 4152.
- Farms, cottage, 7766; of working mechanics, 7767; of village tradesmen and shopkeepers, 7768; occupied with a view to profit by town and city tradesmen, 7769; occupied by city tradesmen for recreative enjoyments, 7770; attached to the villas and country-houses of wealthy citizens, 7771; demesne, 7772; of professional farmers, 7773; Hebridean, 7859.
- Farmstead, the particular requisites of a, 2950.
- Farm-yard dung, management of, 4959.
- Farmer, personal character and expectations of a professional, 4812; capital required by the, 4820.
- Farmer, the jobbing, 7724.
- Farmer's account books, 4886.
- Farmer's apprentices, 4879.
- Farmers, modes of improving, 4606.
- Farmer's Magazine, Anon. page 1211. A. D. 1800—1825.
- Farmer's Register, &c. Anon. page 1214. A. D. 1827.
- Farmers' Society of Dalkeith, 7833.
- Farmeries, Alpine, of Norway, 1260.
- Farmery, a commodious and very complete, 2956; with a threshing machine driven by steam, 2957; a convenient Berwickshire, 2954; a Flemish, 439; corn and stall feeding, anomalous design for a, 4173; examples of different descriptions of, 4158; example of an economical, of 50 or 60 acres, 4166; example of an improved Berwickshire, 4167; example of a Northumberland, of from 400 to 500 acres, 4161; for an arable farm near London of 350 acres, example of a, 4170; for a hay farm, an anomalous design for a, 4172; for a meadow farm of 250 acres near London, 4174; for a turnip soil, example of one of from 600 to 900 acres, 4163; improving the plan of a, 4572; old, improving, 4573; requisites for a, 4156; the first thing to be observed in erecting a, 2812.
- Farming lands, climate in respect to, 4718; soil in respect to, 4743; elevation relatively to, 4764; character of surface in regard to, 4769; aspect in regard to, 4771; situation of, in regard to markets, 4773.
- Farming landlords, 7746.
- Farming, Scotch, in Oxfordshire, 7789.
- Farming Society of Ireland, the, 7921.
- Farriery, as applied to cattle, 2083.
- Fasting, the power of, in some animals, 1995.
- Fat, 1950.
- Fearn farmery, 4162.
- Feathers of animals, 1858; as a manure, 2250.
- Feeding cattle, 3234.
- Feeding, choice of live stock for the purpose of, 4835; for extraordinary purposes, 2084; for promoting the produce of milk or eggs, 2690; to fit animals for hard labour or long journeys, 2091.
- Feeding tub, the, 2527.
- Fee-simple value of lands, 3409.
- Feet of animals, effects of the leverage of, on roads, 3573.
- Fellenberg, Emmanuel, his works on agriculture, page 1220. A. D. 1808.
- Felling timber, proper time and season for, 4056; operation of, 4062.
- Felling trees, 1679.
- Fen plants, 1746.
- Fence, the chain horizontal, 3044; the rope, 3045; the moveable wooden, 3046; the willow or watted, 3049; the upright and horizontal shingle, 3051; the warped paling, 3052; the light open paling, 3053; the primitive paling, 3054; the iron for parks, 3055; the wall, 3056; the Devonshire, 3029; the furze, 3038; the sunk, or ha-ha, 2969; the paling, 3039.
- Fences, along the sides of roads, 3617; emplacement or disposition of, on a farm, 2961; in Ireland, 840.
- Fens of Cambridgeshire, drainage of, 7786.
- Fenugreek, the, 5638.
- Fermanagh, statistics of, 7888.
- Fermentation of cider, 4128; of manures, 2271; checking the, 2273.
- Ferns, extirpation of, 4534.
- Ferrario, G. A., his work on agriculture, page 1222. A. D. 1818.
- Ferret, the, 7428.
- Ferussac, Baron de, his work on agriculture, page 1219. A. D. 1825.
- Fessenden, Thomas G., his work on agriculture, page 1223. A. D. 1822.
- Fête, agricultural, of the Chinese, 1012.
- Fibre, woody, 1492; as a manure, 2240.
- Fibrin, in animals, 1941.
- Fibrine, 1407.
- Field-beet, 5482; best variety of, 5483; soil for, 5484; produce of, 5486; application of, 5488; saving the seed of, 5495; diseases of, 5496.
- Field-gate, Dutch, 53; Menteth's, 3095; Hunter of Thurston's, 3096.
- Field ponds, the situation of, 4475.
- Fields, floating, of the Mexicans, 1179.
- Fields, the form and size of, 4187.
- Fife Farming Society, the, 7848.
- Fifeshire, statistics of, 7848.
- Fig, the Indian, in Spain, 724.
- Figs of the Morea, 753.
- Filbert, as an orchard fruit, 4104.
- Filices, 1329.
- Filtering apparatus for salt water, 4509.
- Filtering, operation of, 4505.
- Findlater, Rev. Charles, his work on agriculture, page 1212. A. D. 1802.
- Finland, state of agriculture in, 689.
- Finlayson, John, his works on agriculture, page 1213. A. D. 1822.
- Finlayson's rid-plough, 4540.
- Finorchi, Anton. Maria, his works on agriculture, page 1222. A. D. 1816.
- Fiorin hay, 5807.
- Fir, the Norway, great value of, 700.
- Fischer, C. F. J., his work on agriculture, page 1219. A. D. 1785.
- Fischer, H. L., his work on agriculture, page 1220. A. D. 1797.
- Fish, as a manure, 2246.
- Fish, cultivation of, in Britain, 7569; kinds of, adapted for ponds, 7572; castration of, 7588.
- Fisheries in Sutherland, 7866; marine, 3875; river, lake, and inland, 3885; of China, 994.
- Fishing and hunting as the only means of subsistence, geographical extension of, 1257.
- Fish-ponds, 7570; sea water, 7571; in Berkshire, 7790.
- Fitzherbert's book of surveying and improvements, 220.
- Fitzherbert, Sir Anthony, his works on agriculture, page 1206. A. D. 1523.
- Flail, the, 2474; threshing by the, 3198.
- Flax, culture of, in Egypt, 1080; in the Netherlands, 479; in Russia, 677; varieties of, 5881; soils for, 5882; preparation of the soil for, 5886; sowing, 5887; after culture of, 5892; taking the crop, 5894; dressing, 5912; produce of, 5916; use of, 5919; diseases of, 5921.
- Fleming, his work on agriculture, page 1214. A. D. 1826.
- Fleming, Malcolm, M. D., his work on agriculture, page 1223. A. D. 1754.
- Floating upwards, 4443.
- Floodgate, 4344.
- Flooding, 2207; an example of the benefit of, 4442.
- Flora, British, purchasable, 1808; application of the, 1813; the purchasable of, 1829, 1822; the artificial, 1804; native countries of the, 1805; dates of the introduction of, 1806; obvious character of, 1807; genera of, 1802; uses or application of the, 1803.
- Flour-mill, a hand, 2551.
- Flour-mill, the potato, 2559.
- Flower of a plant, 1322; anomalies in the, 1611; short lived, 1719.
- Flowering, premature, 1684.
- Flowers, the most showy herbaceous, of the temperate zone, 1792.
- Flower-stalk of a plant, 1323.
- Flower-stalk of plants, 1357.
- Floyd, Edward, his works on agriculture, page 1207. A. D. 1694.
- Fluids, animal, 1956.
- Flux of juices in plants, 1699.
- Flying, the action of, 1907.
- Fogging pasture lands, 5837.
- Fontalard, Jean François de, his works on agriculture, page 1217. A. D. 1794.
- Food, the best way of supplying it to animals, 2071.

- Food of plants, 1521; as supplied by manures and culture, 1533.
 Footpaths, 3537.
Forbes, Francis, his works on agriculture, page 1209. A. D. 1778.
Fordyce, George, M. D., F. R. S., his work on agriculture, page 1208. A. D. 1765.
 Forester, 7719.
 Forests of China, 1011.
 Forests of the Morea, 755.
 Forfarshire, see Angus, 7850.
 Forking, 3128.
 Forking up crops, 3182.
 Forks, the various kinds of, 2448; used in irrigation, 4402.
 Form of cattle, to obtain the most improved, 2050.
 Forms, the best, for cattle, 2043.
Forster, John, his work on agriculture, page 1207. A. D. 1664.
Forsyth, Robert, Esq., his work on agriculture, page 1212. A. D. 1804.
 Foulah country, description of the, 1104.
 Fowls, gallinaceous, their kinds, breeding, rearing, and management, 7438; anserine or aquatic, 7497.
 Fowls, fattening of, for the London market, 2086.
 Fox, the, 7625; to shoot, 7626.
 Fractures in trees, 1676; treatment of, 4029.
 Frame for drying corn on in Russia, 683.
 France, agriculture of, during the middle ages, 185; first agricultural survey of, 380; favourable circumstances of, 381; present state of agriculture in, 382; retrospective view of the agriculture of, 383, 384; agriculture of, in 1819, 385; surface of, 386; soil of, 387; climate of, 388; the central climate of, 389; the vine and maize climate of, 390; the olive climate of, 391; the lands of, 393; value of landed property in, 394; the farming of lands in, 395; corn farming in, 396; meadows of, 397; sheep of, 398; beasts of labour in, 399; dairies of, 400; goats of Thibet in, 401; poultry in, 402; swine of, 403; fish ponds of, 404; implements and operations of the farms of, 405; the large farms of, 406; plants grown in, 407; forest culture of, 408; leaves as food for cattle in, 409; farm-houses and offices in the warm districts of, 411; the old plough of the warm districts of, 411; one handled plough of the south of, 411; rotation of crops in the south of, 412; live stock of the south of, 413; chick pea of the Provençals, 413; vine in the south of, 414; white mulberry in the south of, 415; the olive in the south of, 417; the fig in the south of, 418; the almond in the south of, 419; the caper in the south of, 420; the orange in the south of, 421; the winter melon in the south of, 422.
Francès, Aîné, his work on agriculture, page 1218. A. D. 1822.
François, Nicholas, his works on agriculture, page 1215. A. D. 1763.
Franque, Dr., his work on agriculture, page 1220. A. D. 1825.
Fraser, Robert, Esq., his works on agriculture, page 1210. A. D. 1793.
 Friction, effects of, on roads, 3572.
 Friesland, swing plough of, 604.
 Frog, the esculent, 7590; the tree, 7591.
Fromage de Feugré, C. Michel F., his work on agriculture, page 1217. A. D. 1802.
 Frond of a plant, 1311.
 Frost, origin of, 2373.
 Fruit of plants, 1326; anomalies in the, 1616; maturation and decay of, 1720.
 Fruiting, premature, 1684.
 Fruits, of the northern hemisphere, 1787; of the E. Indies, 1788; of China, 1789; of Africa, 1790; of S. America, 1791.
 Fruit trees, insects injurious to, 7680.
Fry's means of preserving roads, 3739.
Fry's opinion of narrow roads, 3601.
 Fuller's thistle. See Teasel.
 Fungi, 1335; uses of the, 1366.
 Funnel formed in circular stacks, 3284.
 Furrow-roller, the, 2712.
 Furrow-slice, breadth and depth of the, 3241; degree to which it turns over, 3242; the most generally useful breadth of, 3246.
 Furze-bruiser, 2553.
 Furze fence, the, 3038.
- G.
- Gaçon Dufour*, Marie Armande Jeanne, his work on agriculture, page 1218. A. D. 1807.
Gagliardo, G. B., his work on agriculture, page 1222.
 Gaiting of corn, 3176.
Galb, J., his work on agriculture, page 1220. A. D. 1826.
 Galbanum, 1473.
 Galicia, state of agriculture in, 648.
 Gallinaceous fowls, their kinds, breeding, rearing, and management, 7438.
Gallixioti, Filippo, his work on agriculture, page 1222. A. D. 1815.
Gallo, Agostino, his works on agriculture, page 1221. A. D. 1564.
 Galloway, statistics of, 7840.
 Galway, statistics of, 7883.
 Gamboge, 1480.
 Gangrene in plants, 1704.
 Gaps of plants, 1389.
 Garden farmers, 7728.
 Gardens appended to the labourers' cottages, 2918.
 Gardens of mechanics in Lancashire, 7812.
 Gas, azotic, in animals, 1921; carbonic acid, in the atmosphere, 2337; carbonic acid, its effects upon germination, 1524.
 Gases, as the food of plants, 1523.
 Gate, the, 3075; construction of, 3076; the hanging of, 3081; the improved swing, of the northern counties, 3093; Parker's improved swing, 3094; the tressel bar, 3101; the slip bar, 3102; the chained slip bar, 3103; the double or folding, 3105; Clark's window sash, 3106; Parker's compensation hinge for, 3082.
 Gate posts, 3086.
 Gates, fastenings of, 3088; iron, 3085; iron, used in Monmouthshire, 7793; of fields, the proper situation for, 4202.
 Gathering, 3136; orchard fruit, 4120.
Gautieri, Giuseppe, his works on agriculture, page 1221. A. D. 1807.
Gavellus, Nicholas, his work on agriculture, page 1221. A. D. 1758.
 Gelatine, in animals, 1937; use of, 1938.
 Gems of plants, 1359.
 Generation, equivocal, 1640.
 Gentlemen farmers, 7744.
 Georgia, 1246.
 Germany, agriculture of, in the time of the Romans, 175; agriculture of, during the middle ages, 192; present state of agriculture in, 547; soil, surface, and climate of, 548; landed property in, 549; farmers of, 550; consequence of the regulations of landed property in, 551; agricultural produce of, 553; culture of the mulberry and rearing of the silkworm in, 554; the common cultivation of, 555; the best pastures and meadows in, 556; operations and implements of agriculture in, 557; the live stock of, 558; forests in, 559; general state of common agriculture in, 560.
 Germination, 1512; the first condition necessary to, 1513; the second condition, 1514; a third condition, 1515; a fourth condition, 1516; a fifth condition, 1517; period necessary to complete, 1518; physical phenomena of, 1519; chemical phenomena of, 1520; effect of carbonic acid gas in, 1524; effects of oxygen, nitrogen gas, and hydrogen gas on, 1525—1527.
 Ghost moth, the, 7674.
Giacinto, Carlo, his work on agriculture, page 1222. A. D. 1811. and 1825.
Gialdi, Giuseppe, his work on agriculture, page 1222. A. D. 1818.
Gibbs's select list of orchard fruits, 4097.
Gilbert, François Hilaire, his works on agriculture, page 1217. A. D. 1797.
Gilbert, H. F., his work on agriculture, page 1219. A. D. 1826.
 Girdling trees, 1675.
Gladstone's attempt at a reaping machine, 2734; his machine for reaping beans, 2740.
 Glands of plants, 1314.
 Glossology, 1292.
 Gloucestershire, statistics of, 7791.
 Gluten, 1405.
 Glycèria fluitans, 5187.
 Goat, the, 7331; the Angora, 7332; the Syrian, 7333; the chamois, 7334; the Welsh, 7335; produce of the, 7336; hair of the, 7337; suet of the, 7338; choice of, for keeping, 7339; the Cashmere shawl, 7340; the Hindustan, 914.
 Goats on the Cheviot Hills, 7809.
 God speede the Plough. Anon. Page 1207. A. D. 1601.
 Gold fish, 7581.

- Gongylus of plants, 1363.
Good's improved boring instruments, 2507.
 Goose, the, 7511; flesh of, 7512; varieties and species of, 7513; breeding, 7515; rearing, 7516; feathers, 7517.
 Gooseberry, as an orchard fruit, 4104.
Gotthard, J. Ch., his work on agriculture, page 1220. A. D. 1802.
Graffen, F. G. his work on agriculture, page 1220. A. D. 1825.
 Grafting trees, 1678.
 Grain, principal, of Ireland, 837.
 Grain drill-machine, Morton's improved, 2682.
 Granary, agricultural, construction of, 2858; a detached, 2859; commercial corn, 2860; to preserve corn for many years, 2861.
 Granary in barns with threshing machines, 2857.
 Grasping, the action of, in animals, 1895.
 Grass lands, breaking up, 5846; advantages of, 5857; disadvantages of, 5861; that ought not to be broken up, 5850.
 Grass, the cock's foot, 5661; the woolly soft, 5664; the fescue, species of, 5670; the meadow foxtail, 5673; the cat's tail, or Timothy, 5681; the floating fescue, 5683; the water meadow, 5685; the florin, 5687; the sweet-scented vernal, 5698; the downy oat, 5699; the annual meadow, 5700; the fine bent, 5701; the narrow-leaved meadow, 5702; the hard fescue, 5707; the yellow oat, 5709; the forage, 5643; the hay, 5652. 5680; the pasturage, 5693; late pasture, 5705; waste of, on being made into hay, 5803.
 Grass, cutting second crops of, 3169.
 Grass crops, cutting, for being converted into hay, 3168.
 Grass-harrow, 5820.
 Grasses affording the best culms for straw-plait, 5764.
 Grasses, cereal, culture of, 4982.
 Grasses, indigenous, of Ireland, 839.
 Grasses, mixture of, in pastures, 5717; nutritive products of, 5722; pasture, for inferior soils, 5706; for inferior soils and upland situations, 5710; Sir H. Davy's table of the nutritive products of, 5668.
 Grassing flax, 5909.
 Gravel for making roads, 3642.
 Gravity, centre of, in the plough, 2636.
Gray, Andrew, his work on agriculture, page 1212. A. D. 1808.
 Graziers, 7734.
 Grecian agriculture, products of, 34.
 Greeks, agriculture of the, 25; beasts of labour of the, 32.
 Greenland, rural economy of, 566.
Greenway, Dr. James, his work on agriculture, page 1223. A. D. 1828.
 Grilses, 7850.
 Grinding, effect of, on roads, 3577.
 Grinding fruit for cider, 4125.
Grisenthwaite, William, his work on agriculture, page 1213. A. D. 1820.
 Grist mills, 3842.
Grosbede, Bishop of Lincoln, his work on agriculture, page 1206. A. D. 1500.
 Grounds, wet or boggy, drainage of, 4234.
 Grouse, the red, 7559; the black, 7560; the wood, 7561.
 Grub, the, 7685.
 Grubber, Kirkwood's improved, 4955.
 Guaiac, 1464.
 Gudgeon, 7577.
 Guide-posts, improved, 5724.
Guillaume, Ch., his work on agriculture, page 1218. A. D. 1821.
Guillot, Julien Jean Jacques, his work on agriculture, page 1215. A. D. 1761.
 Guinea hen, 7493.
 Guinea pig, the, 7366.
 Gum, excessive exudations of, to remedy, 4036; exudations of, in plants, 1701; uses of, 1397.
 Gum-resins, 1472.
 Gunpowder, rending rocks or stones by, 4524.
 Gutter, a, 4418.
 Gypsum, as a manure, 2296; the nature of, 2297; operation of, 2298.
- H.
- Habit of plants anomalies of the, 1618.
 Habits, old, adherence to, by the illiterate, 7857.
 Hacks used in irrigation, 4402.
 Ha-ha, the, or sunk fence, 2969.
 Hail, 2375.
 Hainault mowing, the, 3172.
 Hair as a manure, 2250.
 Hairs differ in form, 1855, grow by the roots, 1856; of animals, 1851; colour of, 1854; durability of, 1857.
 Hamburg, state of the proprietors of free lands near, 603.
Hamel, Du Monceau, Henry Lewis du, his works on agriculture, page 1215. A. D. 1750.
 Hammers, 2490.
 Hammocks of the Brazilians, 1239.
 Hampshire, statistics of, 7815.
 Handbarrows used in irrigation, 4399.
 Hand-drill, the broad-cast, 2576.
 Hand-drilling machines, 2573.
 Hand-hoe, the, 2458; for turnips, 5406.
 Hand-hoeing, 3130.
 Hand-machines, agricultural, 2537.
 Hand-machines, the essential, 2583.
 Hand-raking, 3132.
 Hanover, agriculture of, 592; agricultural societies of, 593; landed property in, 594; land of religious corporations in, 595; occupiers of land in, 596; free landed property of, 597; the large farmers of, 598; farming of the cultivators of free lands in, 602; farming of the bauers of, 605; way to improve the agriculture of, 606.
 Happiness, the constituents of, 7960.
 Hardiness of constitution, advantage of, in live stock, 2025.
 Hare, the, 7364; hare warren near Banstead Downs, 7365.
Harley's cow-house at Glasgow, 2832.
Harley, William, his work on agriculture, page 1214. A. D. 1829.
 Harnessing cattle, 3235.
Harrison, Gustavus, Esq., his work on agriculture, page 1209. A. D. 1775.
 Harrow, the, 2696; the Berwickshire, 2697; the angular-sided hinged, 2698; the grass seed rhomboidal, 2699; the levelling, 2701; Morton's revolving brake, 2702, 2703; the brush, 2705; the only essential, 2706.
 Harrowing, 3261.
 Harrows, circular, 7787; Finlayson's self-cleaning, 2657.
Hartig, Fr. Grafen von, his work on agriculture, page 1219. A. D. 1786.
Hartiz, Georges Louis, his work on agriculture, page 1219. A. D. 1790.
Hartlib's Legacy, 252.
Hartlib, Samuel, his works on agriculture, page 1207. A. D. 1651.
 Harvest waggon of Cornwall, the, 7825.
 Hash, the Sithney, 2716.
Hastfer, F. W., his work on agriculture, page 1215. A. D. 1756.
 Hatches, 4410.
 Hawks and hunting birds, 7568.
 Hay, mode of drying, in the Hebrides, 7859; salting of, 5808.
 Hay-barn, the, 2856.
 Hay-binding machine, 2561.
 Hay farmers, 7737.
 Hay-knife, the, 2484.
 Haymaking, general rules for, 5799; in Middlesex, 5792.
 Hay-rake, the, 2450.
 Hay-stack, proper size for the, 3278; the building of, 3286; of Middlesex, 3287. 5801.
 Hay-stands, 2910.
 Hay swoop, the, 2729.
 Hay-tedding machine, the, 2728. 5800.
 Hay-tea, to make, 5809.
Hayward, Joseph, his work on agriculture, page 1213. A. D. 1825.
Haxxi, M. de, his works on agriculture, page 1220. A. D. 1825, 1826, 1828.
 Head of a meadow, 4423.
 Head driver of slaves in Jamaica, 1202.
 Head main, 4411.
 Heading down on resinous trees, 5999.
Headrick, James, his works on agriculture, page 1212. A. D. 1807.
 Heads of loose stones for confining rivers, 4379.
 Heads for the confinement of water in artificial lakes, 4378.
 Health of domestic animals, how to preserve, 2082.
 Heat, a certain quantity of, necessary for animals, 2075; influence of, on the vital principle of plants, 1659; the nature of, 2314; radiated by the

- sun to the earth, 2315; reflected back by dense clouds, 2316; arrested by fogs, 2317.
- Heath lands, improvement of, 4535.
- Hebrides, statistics of the, 7859.
- Hedge, after management of the, 2982—2986. 3020.
- Hedge and bank, the, 3027.
- Hedge, breasted over, after management of, 3023.
- Hedge and dead hedge, the, 3031.
- Hedge and ditch, the single, 2996; Stephens's mode of forming and planting, 2997; with belt, of planting, 3036; with row of trees, 3034.
- Hedge fences, 2972.
- Hedge in the face of a bank, 3028; in the middle or in the face of a wall, 3033.
- Hedge and wall fence, 3032.
- Hedge-bills, 2459.
- Hedger, 7714.
- Hedge-row timber, neglected, to improve, 4027; objections to, 4200.
- Hedges, Stephens's opinion on planting trees in, 3035.
- Hedges, cutting, with a knife, 7843.
- Hedges, filling up gaps in, 2993; forming in curved lines, 3007; gates and gate posts in, 3019.
- Hedges, dead, 2973; how made, 2974.
- Hedges, live, 2975; old management of, 2987; to mend the defects of, 2994; cutting over, 2988. 3021; the plashing of, 3025; the laying of, 3026; operation of cleaning, 3012; pruning, 3013; protecting fence for, 3015; protecting by a paling, 3016; protecting by stake and rise, 3017; protecting by a turf wall and single rail, 3018; the proper choice of plants for, 2976; age at which they ought to be used, 2978; size of, 2979; assorting of, 2980; dressing and pruning of, before they are put into the earth, 2981; with posts and rails, 3030; preparation of the soil for, 2977; season of planting, 3008; implements for forming and managing, 2998 and 3010.
- Hedge-shears, 2486.
- Hedging and ditching, 3205.
- Hegemon*, Philibert, his work on agriculture, page 1214. A. D. 1583.
- Hemp, 5982; soils for, 5923; sowing, 5925; taking the crop of, 5926; produce of, 5931; uses of, 5932; culture of, in Russia, 677; use of, in Egypt, 1081.
- Hen, see Cock and hen, 7439.
- Henderson*, Robert, his work on agriculture, page 1212. A. D. 1811.
- Hepaticæ, 1331.
- Herbs, oleraceous, of temperate climates, 1786.
- Herding, 3232.
- Herefordshire, statistics of, 7794.
- Heresbachius*, Conradus, his work on agriculture, page 1219. A. D. 1578.
- Hermstädt*, Sgm. F., his work on agriculture, page 1220. A. D. 1803.
- Heron, the, destructive to young salmon, 3890.
- Herring fishery, 3876.
- Hertfordshire, statistics of, 7782.
- Hesiod*, his writings, 26.
- Hesson*, Jacques, his work on agriculture, page A. D. 1214. A. D. 1569.
- Highland Society of Scotland, the, 7918.
- Higgins*, Jesse, his work on agriculture, page 1223. A. D. 1828.
- Hills, improvement of, 4514.
- Hills and mountains, to measure the elevations and shapes of, 3350.
- Hiltensbrand*, Ant. his work on agriculture, page 1219. A. D. 1784.
- Hinds in East Lothian, 7834; plan of maintaining, in the best cultivated districts in Scotland, 4870.
- Hindustan, climate and seasons of, 890; surface of, 891; soil of, 892; landed property in, 893; agricultural products of, 894; fruits of, 909; natural pastures of, 910; live stock of, 911; implements and operations of agriculture in, 919; artificial watering in, 921; culture in the hilly districts of, 924; harvests in, 925.
- Hinny, the, 6768.
- Hitt*, Thomas, his work on agriculture, page 1208. 1760.
- Hives, best material and form for, 7605; size of, 7606; Polish, 7607; protecting from the cold, 7609; taking the honey from, 7611.
- Hoe and castor wheel, the, 2675.
- Hoe, the Dutch, 2460; the thrust, 2461; the Spanish, 2462; the pronged, 513.
- Hoe-fork, 2463.
- Hoe scythe, the, 2676.
- Hoing between rows of crops, 3131.
- Hoes, improvements in, 2459.
- Hoffman*, A., his work on agriculture, page 1220. A. D. 1809.
- Hofmann*, Gli. Bd. Freyherr von, his work on agriculture, page 1219. A. D. 1784.
- Hogs of Buckinghamshire, 7783.
- Hog sties, 2837.
- Holdich's* classification of weeds, 6205.
- Holditch*, Benjamin, his work on agriculture, page 1213. A. D. 1825.
- Holland, climate of, 425; landed property of, 426; agriculture of, 427; field implements, buildings, and operations of, 428; simple fieldgate of, 428.
- Holland*, Henry, Esq., M. D., his work on agriculture, page 1212. A. D. 1807.
- Hollowness in trees, to remedy, 4032.
- Holt*, John, his works on agriculture, page 1210. A. D. 1795.
- Home*, Francis, M. D., his work on agriculture, page 1208. A. D. 1757.
- Home*, Henry, his work on agriculture, page 1209. A. D. 1776.
- Homer*, Henry, his works on agriculture, page 1208. A. D. 1766.
- Honey, Polish, its three classes, 655.
- Honey-bee, see Bee, 7602.
- Honey-dew in plants, 1695.
- Hood*, Thomas Sutton, Esq., his work on agriculture, page 1212. A. D. 1805.
- Hoofs of animals, 1863.
- Hop, the, 5997; varieties of the, 6000; soils for the, 6002; planting of the, 6008; after culture of the, 6016; dressing the plants of, 6021; taking the crop of the, 6036; produce of the crop of the, 6050; use of the, 6054; diseases of the, 6056; substitute for the, 6072.
- Hop, the insects injurious to the, 7671.
- Hop farmers, 7731.
- Hop flea, the, 7672.
- Hop louse, the, 7673.
- Hop-poles, setting, 6023.
- Hops, culture of, in the reign of Henry VIII., 217; culture of, in the Netherlands, 484; drying, 6041; bagging, 6044; duty on, 6064.
- Horn as a manure, 2249.
- Hornby*, Thomas, Esq., his work on agriculture, page 1213. A. D. 1815.
- Horned cattle, 6773; the ox or bull, 6774; varieties of, 6775; wild varieties, 6775; bonassus and bison, 6775; varieties of the European cow, 6776; uris, or cows of Lithuania, 6776; diversity of milk in cows, 6777; varieties of the cultivated ox, 6778; long-horned or Lancashire breed, 6779; short horn or Dutch breed, 6780; Holderness, Teeswater, Yorkshire, Durham, and Northumberland breeds, 6780; middle-horned breeds — Devon, Sussex, and Herefords, 6782; Devonshire cattle, 6783; Sussex and Herefordshire cattle, 6785; polled or hornless cattle, 6786; Galloway cattle, 6786; Suffolk duns, 6788; Ayrshire cattle, 6789; origin of, 6790; size, 6791; shape, 6792; qualities of an Ayrshire cow, 6794; Highland cattle, 6795; Argyleshire cattle, 6796; Fifeshire cattle, 6798; Aberdeenshire cattle, 6800; Alderney cattle, 6802; Irish cattle, 6803; wild cattle, 6804; habits of, 6805; calving, 6806; castration of the calf, 6807; killing the calf, 6808; criteria of a well made bull, 6809; criteria of excellence in neat cattle in general, 6810; criteria of an ox well adapted to labour, 6811; criteria of a beautiful cow, 6812; Culley's marks of a good cow, 6813; criteria of excellence as derived from colour, 6814; criteria of age, 6815; terms applied to different ages, 6816; natural duration of life with the bull and cow, 6817; breeding, 6818; rearing, 6827; fattening calves by suckling, 6843; fattening cattle, 6852; Booth's establishment for fattening cattle at Brentford, 6861; management of cows kept for the dairy, 6863; Harley's dairy establishment at Glasgow, 6882; the London dairies of most eminence, 6896; defects of the London dairy establishments, 6907; working of oxen, 6908; harness for labouring cattle, 6911; shoeing of oxen, 6913; anatomy and physiology of the bull and cow, 6921; diseases, 6958.
- Horns of animals, 1859; the markings of the, 1860; colour of the, 1861.
- Horns, and similar parts, composition and use of, 1867, 1868.
- Horse, the, 6216; varieties of, 6218; the Arabian, 6219; European varieties of, 6220; the Spanish, 6221; the French, 6222; the Flemish, 6223; the

- Dutch, 6224; the German, 6225; the Polish, 6226; the Russian, 6227; the Swedish, 6228; British varieties of saddle, 6229; the racer, 6230; the hunter, 6232; the improved hackney, 6233; the old English road, 6234; the Irish road or hunter, 6236; the British varieties of saddle, of more inferior description, 6237; British varieties of war or cavalry, 6238; varieties of draught, 6239; the black, 6240; the Cleveland bays, 6241; the Suffolk punch, 6242; the Clydesdale, 6243; the Welsh, 6244; the Galloway, 6245; smaller horses of the Highlands and isles of Scotland, 6246.
- Horse, organology or exterior anatomy of the, 6247; organs of the head, 6249; the ears, 6250; the forehead, 6251; the eyes, 6252; the face, 6255; the muzzle, 6257; the lips, 6258; the teeth, 6260; organs of the neck, 6261; organs of the trunk or carcass, 6265; the shoulders, 6266; the withers, 6268; the breast or counter, 6269; the back, 6270; the loins, 6271; the croup, 6272; the flank, 6273; the belly, 6274; the whirlbone, 6275; the stifle, 6276; the fore extremities or legs, 6277; the arm, 6278; the knee, 6280; the cannon or shank, 6282; the pastern and fetlock, 6284; the feet, 6286; the hinder extremities, 6291; colour, 6294; colour as a criterion of mental and personal qualities, 6298.
- Horse, bony anatomy or osseous structure of, 6299; bones of the head, 6300; bones of the face, 6301; teeth, 6302; the trunk, 6306; the limbs, 6313; general functions of the bony skeleton, 6329.
- Horse, anatomy and physiology of the soft parts of, 6333; appendages to bone, 6334; muscles, 6340; tendons, 6341; blood-vessels, 6343; absorbents, 6352; nerves, 6353; glands, 6356; integuments, 6357; the brain, 6366; ears, 6367; the eye and its appendages, 6370; nose and sense of smelling, 6379; the mouth, 6381; the tongue, 6383; sense of tasting, 6384; the voice, 6387; the neck, 6389; the chest, 6391; the heart, 6394; circulation of the blood, 6395; lungs, 6396; respiration, 6397; the abdomen, 6398; the foetal colt, 6412; the foot, 6416.
- Horse, diseases of, 6422; general remarks on the healthy condition and diseased state of, 6423; inflammatory diseases of, 6426; diseases of the head, 6438; diseases of the neck, 6449; diseases of the chest, 6452; diseases of the skin, 6487; diseases of the extremities, 6497; diseases of the feet, 6517.
- Horse, veterinary operations on, 6530; treatment of wounds, 6531; giving balls, 6532; giving drinks, 6533; fomentations and poultices, 6534; setons, 6537; rowels, 6538; blistering, 6539; firing, 6542; clystering, 6543; physicking, 6544; castration, nicking, docking, &c., 6546; bleeding, 6547.
- Horse. Veterinary pharmacopœia, 6548.
- Horse. Shoeing, 6594; improved shoe for general use, 6595; injurious effects of bad shoeing, 6596; improved shoe on the present plan, 6598; to prepare the foot for the application of the shoe, 6599; shoes for the hind feet, 6600; the bar shoe, 6601; the hunting shoe, 6602; the racing shoe, 6603; grass shoes, 6604; frost shoes, 6605; high calkins, 6606; shoeing of diseased feet, 6607; horse patents, 6608.
- Horse, criteria of the qualities of, for various purposes, 6609; of action, 6611; of hardihood, 6612; of spirit, 6613; of a race-horse, 6614; of a hunter, 6615; of a hackney, 6616; of a cavalry horse, 6617; of road horses for quick draught, 6618; of a dray-horse, 6619; of a waggon horse, 6620; of a horse peculiarly adapted to the labours of agriculture, 6621; of a horse's age, 6625.
- Horse, breeding of, 6629; choosing the parents, 6631; properties required in a breeding mare, 6632; age proper for breeding, 6634; season for the generative process, 6636; to bring a mare in season, 6639; treatment of a pregnant mare, 6640.
- Horse, rearing of, 6644; treatment of the mare till she has weaned her foal, 6645; treatment of weaned foals, 6647; time for gelding colts, 6650.
- Horse, training of, 6653; directive language used to, 6654; of saddle horses, 6656; backing, 6657; teaching the different movements of walking, trotting, galloping, and ambling, 6658; of coach horses, 6668; of cart and plough horses, 6670.
- Horse. Horsemanship, 6671; manege riding, 6672; the art of proper riding, 6673; use of the curb bridle, 6674; best form of saddle, 6675; to mount with ease and safety, 6676; a graceful and proper seat, 6677; to sit a vicious horse, 6678; to manage an unruly horse, 6679; advantage of spurs, 6680; what should be done previously to mounting, 6681; dismounting, 6682; the jockey mode of riding, 6683.
- Horse, feeding of, 6684; food of British horses, 6685; hay, 6686; grain, 6687; pulse, 6688; roots, 6689; mixtures, 6690; cooked food, 6691; quantity of food, 6692; a horse in full work, 6694; watering, 6695.
- Horse, stabling and grooming, 6697; the stable, 6698; form of the rack and manger, 6702; stalls, 6703; litter, 6705; clothing, 6707; grooming or dressing, 6708; the curry-comb, 6709; care of the legs and feet, 6710; care of the furniture and trappings, 6711; exercising, 6712.
- Horse, management and working of, 6714; managing and working race-horses, 6715; treatment of a race-horse in low flesh, 6716; treatment of, in good flesh and spirits, 6717; choice of a rider, 6718; whipping the horse, 6719; running on level smooth ground, 6720; riding up hill, 6721; after management, 6723; treatment when the race is over, 6724; managing and working of the hunter, 6725; physicking of hunters, 6728; working and managing of hackneys or riding horses, 6723; working and managing horses in curricles, 6741; working and managing cart and waggon horses, 6743.
- Horse of Arabia, 886. 2057; of India, 2058.
- Horses, breed of, in the time of Elizabeth, 227; breeding of, in the time of Henry VIII., 218; of the Cape of Good Hope, 1130; draught, of Clydesdale, 7842; description of, required by the farmer, 4833; of Egypt, 1086; of Galloway, 7840; of the Hebrides, 7859; the Hungarian, 634; the Lanarkshire, 7842; of Leicestershire, 7798; of Perthshire, 7849; labour of, in a day, 3238; large, for farmers, Davis's objections to, 4834; laws for turning, to grass in Scotland during the 16th century, 229.
- Horse-hoe and drill-plough, Wilkie's, 2668.
- Horse-hoe and harrow, Amos's expanding, 2674.
- Horse-hoe for turnips, 5404.
- Horse-hoeing, 3264.
- Horse-hoes, 2665; the only essential, 2677; Weir's expanding, 2669; Blaikie's inverted, 2670; the Scotch, 2671; the Northumberland, 2672; and drill-harrow, Wilkie's, 2666; Finlayson's self-cleaning, 2667.
- Horse-rake, the common or Norfolk, 2724.
- Horse-raking, 3271.
- Horse roads, 3536.
- Hortus Britannicus, the, of 1829, 1822.
- Hot water, incubation of chickens by, 7464.
- Hottentots, huts of the unimproved, 1135; cattle of the, 1136.
- Houghton, John, F. R. S., his work on agriculture, page 1207. A. D. 1681.
- Hours of consecutive labour to which animals are subjected, 3237.
- House-cricket, 7691.
- Housekeeping, hints respecting, 4922.
- Housing crops, 3250.
- Huber, Francis, his work on agriculture, page 1220. A. D. 1796.
- Huber, M., his work on agriculture, page 1220. A. D. 1825.
- Huber, P., his works on agriculture, page 1220. A. D. 1801.
- Hummeling barley, cheap method of, 2799.
- Hummeling machine, Mitchell's, 2797.
- Hummeling mashes, hand, 2800.
- Hunger, the cause of, and means of allaying, 1964.
- Hunt, Charles Henry, Esq., his work on agriculture, page 1212. A. D. 1810.
- Hunter, Alexander, M. D., F. R. S., L., and E., his works on agriculture, page 1209. A. D. 1770.
- Hunting and fishing as the only means of subsistence, geographical extension of, 1257.
- Huntingdonshire, statistics of, 7785.
- Hurdles, 3046; ornamental wooden, 3047; iron, 3048.
- Hurdling off clover crops, 5561.
- Huzard, Jean Baptiste, his works on agriculture, page 1217. A. D. 1794.
- Hybrids, 1631.
- Hydrogen in animals, 1919.
- Hygrometer, use of the, 2419; Professor Leslie's, 2425; the steel-yard, 2422; the hair, 2424.

- Il Fattore di Campagna. Anon. page 1222. A. D. 1826.
- Implements, agricultural, choice of, 4852; the fundamental, 2584; invention of, 10; for forming and managing hedges, 2998. 3010; of husbandry among the Anglo-Saxons, 203; after the Norman conquest, 206; of irrigation, 4392; pronged tillage, 2650; the only essential, 2664; tillage, of agriculture, 2585.
- Impregnation, in birds, 1975; in fishes and reptiles, 1976; in insects, 1977.
- Impregnation of the seed, 1625; changes consequent upon, 1636.
- Improvements, execution of, 4600; general cautions respecting the, 4616.
- Incisions in trees, 1673.
- Independence the grand object of labour, 7957.
- Indigo the finest of vegetables blue for dyeing, 1415.
- Indigo plant, the, in Hindustan, 896.
- Indigo of the West Indies, 1214.
- Inflorescence of plants, 1325.
- Insects, injurious to agriculture, 7643; physiology of, 7644; arrangement or classification of, 7650; Mandibulata, 7652; Trichoptera, 7652; Hymenoptera, 7652; Coleoptera, 7652; Orthoptera, 7652; Neuroptera, 7653; Haustellata, 7653; Lepidoptera, 7653; Diptera, 7653; A'ptera, 7653; Hemiptera, 7653; Homoptera, 7653.
- Insects injurious to live stock, 7655; to the horse, 7656; to horned cattle, 7657; to sheep, 7658; to fish, 7659.
- Insects injurious to vegetables, 7660; to wheat, 7661; to rye, 7662; to barley, 7663; to oats, 7664; to peas, 7665; to beans, 7665; to turnips, 7667; to hops, 7671; to clover, 7675; to pastures, 7676; to cabbages and other esculent vegetables, 7679; to fruit trees, 7680; to plantations, 7681.
- Insects injurious to food, clothing, &c., 7689; the cock-roach, 7690; the house-cricket, 7691; the bacon-grub, 7692.
- Insects, operations for subduing, 7695; preventive operations, 7696; palliative operations, 7697; by enticement, 7698; the turnip net, 7699; the lime-duster, 7700; amongst grain, 7701; hand-picking, 7702; catching the perfect insect, 7703.
- Insects injurious to trees, to destroy, 4037.
- Instinct of plants, 1669.
- Instruments, essential, of labour, 2495; the only essential scientific, 2521; scientific, 2496; used in agriculture, the, 2476.
- Integuments of the seed of plants, 1341.
- Interest the grand mover of animals, 2069.
- Introsusception of nourishment by plants, 1538.
- Inverkeithing Club, the, 7848.
- Inverness-shire, statistics of, 7857.
- Iodine in sponge, 1926.
- Ipecacuana plant, the true, 1234.
- Ireland, state of agriculture in, 807; during the 13th, 14th, and 15th centuries, 808; in the reign of James I., 809; after the rebellion of 1641, 812; in the beginning of the present century, 815; climate of, 816; territorial surface of, 817; soil of, 818; the bogs of, 819; landed property in, 821; circumstances in favour of, 822; leases in, 823; farming in, 824; rent of land in, 825; the nine agricultural districts of, 826; agricultural implements and operations of, 836; principal grain of, 837; the potatoes of, 838; indigenous grasses of, 839; dairies of, 841; cause of the depressed state of agriculture in, 842; condition of the labourers of, 844; contradictory circumstances of, 845; system of under-letting lands in, 847; the tithes in, 848; fertility of, 856; progress of agriculture in, 857; general view of, 7862.
- Iron in animals, 1933.
- Irrigating a meadow from both sides of a river, 4438; an irregular surface from one side of a river, 4439.
- Irrigation, 4381; antiquity of, 4382; theory of, 4385; implements made use of in, 4392; of arable lands, 4460; artificial, 4429; in Cambridgeshire, 7786.
- Irrigation, necessity of, 2203; surface, 2204; subterranean, 2206; rationale of, 2212; by sea-water, 4445; expense of, 4446; objections to, 4447; the principal impediments to, 4448; the formation and arrangement of surfaces for, 4449; Parkinson's opinion on, 7802; subterranean, 4461; in Britain, 4462; terms made use of in, 4404; a very complete example of, 4440; in Wiltshire, 7817.
- Irritability of plants, 1667.
- Island, a floating one, 1180.
- Italy, agriculture of, during the middle ages, 180; climate of, 164; surface of, 165; soil of, 166; native productions of, 167; present state of agriculture in, 260; writers on, 261.

J.

- Jackall, the, of Hindustan, 918.
- Jacob's opinion of the farm at Moegelin, 582; of the agriculture of Saxony, 613.
- Jamaica, description of, 1199; landed property in, 1200; agricultural operations of, 1210; agricultural productions of, 1211; the clovers of, 1223; vermin of, 1224.
- Japan, climate and surface of, 956; soil of, 957; agriculture in, 958; live stock of, 959.
- Java, agriculture of, 940; landed property in, 941; crops raised by the farmer for home consumption in, 942; crops raised by the colonists of, 942; live stock of, 944; implements and instruments of, 945; the poison tree of, 946; roads of, 947.
- Jennings, James, Esq., his work on agriculture, page 1214. A. D. 1830.
- Jersey, statistics of, 7827.
- Jews, agriculture of the, 18.
- Johnson, Cuthbert William, F. L. and H. S., his work on agriculture, page 1213. A. D. 1820.
- Johnstone, John, his work on agriculture, page 1211. A. D. 1797.
- Joints, the true, of the bones of animals, 1890.
- Jones's kiln-drying apparatus, 2532.
- Journal d'Agriculture, &c., des Pays-Bas, &c. Anon. page 1218. A. D. 1816—1830.
- Journal de la Société d'Agronomie pratique, &c. Anon. page 1219. A. D. 1829.
- Journeyman agriculturist, 7713.
- Juan Fernandes, the island of, 1246.
- Juice, the proper, of plants, 1496.
- Juice, proper, descent of the, in plants, 1561.
- Juices, flux of, in plants, 1699.
- Juices, vegetable, circulation of, 1579.
- Junctions, motionless, of the bones of animals, 1889.

K.

- Kaimes, Lord, his description of the tenantry of Scotland, 791.
- Keeping orchard fruit, 4121.
- Keith, George Skeene, D. D., his work on agriculture, page 1212. A. D. 1811.
- Kelp in the Hebrides, 7859; manufacture of, 6188.
- Kennedy, Lewis, Esq., his works on agriculture, page 1214. A. D. 1828.
- Kent, Nathaniel, his works on agriculture, page 1209. A. D. 1775.
- Kent, statistics of, 7780.
- Kentish or Herefordshire wheel, 2631.
- Kerr, Robert, F. R. and A. SS., his work on agriculture, page 1212. A. D. 1809.
- Kerry, statistics of, 7881.
- Kidneybean, the, 5287.
- Kildare, statistics of, 7868.
- Kilkenny, statistics of, 7867.
- Killing animals, effect of the mode of, on their flesh, 2092; the Jewish modes of, 2096; preparation before, 2098.
- Kiln-drying oats and other corns in the straw, 5142.
- Kincardineshire, statistics of, 7851.
- King's county, statistics of the, 7869.
- Kinross-shire, statistics of, 7847.
- Kircudbrightshire, statistics of, 7840.
- Kirkpatrick, H., his work on agriculture, page 1211. A. D. 1796.
- Kirwan, Richard, LL. D., &c., his work on agriculture, page 1211. A. D. 1796.
- Kitchen-garden, 2916.
- Kleine Schriften zur stad und Landwirthschaft, &c. &c. Anon. page 1219. A. D. 1791.
- Knapp, J. L., Esq. F. L. and A. SS., his work on agriculture, page 1212. A. D. 1804.
- Knight, George, his system of paving roads, 3720.
- Knight's opinion respecting cider-making, 4129.
- Knollwall farmery, 4164.
- Knowledge, utility of, 7935.
- Kops, M., his work on agriculture, page 1220. A. D. 1828.
- Krantz, Guillaume, his work on agriculture, page 1220. A. D. 1797.
- Krunitz, J. G., his work on agriculture, page 1216. A. D. 1773.
- Kylanderie, the, 511.

L.

- Labdanum, 1460.
 Labour, farm arrangement of, 4910 ; rules for the, 4913.
 Labour, the rate of, 4905.
 Labourers of Ireland, condition of, 844.
 Labourers on a Jamaica sugar estate, 1203.
 Labourers, proposals for the well-being of, 7964.
 Labourers required on a farm, 4877.
 Lac, 1469.
Lacoste, his work on agriculture, page 1217. A. D. 1801.
 Ladder, the common, 2538.
 Ladies' mantle, the common and alpine, 5642.
Lainar, of Kroy, in Yorkshire, his work on agriculture, page 1208. A. D. 1764.
 Ladrone Isles, the, 1057.
Lafaille, Clement, his works on agriculture, page 1215. A. D. 1762.
Laffenas, Barthelemy de, his work on agriculture, page 1214. A. D. 1604.
Lajons, M. de, his work on agriculture, page 1218. A. D. 1821.
 Lakes, method of draining, 4275.
 Lama, 7386.
Lambert, Joseph, Esq., his work on agriculture, page 1214. A. D. 1829.
 Lambing, early, how to promote, 2089.
Lamoignon, Malesherbes, Chrétien Guillaume, his work on agriculture, page 1217. A. D. 1791.
Lampadius, Augusto Guglielmo, his work on agriculture, page 1222. A. D. 1811.
 Lanarkshire, statistics of, 7842.
 Lancashire, statistics of, 7812.
 Land, extent of, suitable for a farm, 4781.
 Land, improvement of, by water, 4880.
 Land, modes of dividing, 3307 ; new-warped, the best mode of cultivating, 4459 ; the practice of inclosing, origin of, 211 ; price of, among the Romans, 169 ; rent of, 4790 ; in Scotland, 4795 ; in England, 4797 ; in a state of culture, improvement of, 4568.
 Land-agent, 7753.
 Landed property in Egypt, 13.
 Land-guard of loose stones, 4366.
 Land-measurer, the, 7747.
 Land-reeve, 4638.
 Land-steward, 4629. 7720 ; his place of business, 4643.
 Land-stewardship, general principles of business relatively to, 4659.
 Land-surveyor, 4642, 7750.
 Land-valuer, 7752.
 Lands, changing the condition of, as to solar influence, 2214 ; sheltering, 2215 ; shading, 2215 ; commonable, 3476 ; general principles of appropriating and dividing, 2490.
 Lands, waste, improvement of, 4512.
Landeschi, his work on agriculture, page 1222. A. D. 1817.
 Lanes, 3532.
Langton, Mr., his process of seasoning timber, 4063.
 Laos, description of the kingdom of, 952.
 Laplanders' cottages, 694.
 Lark, the, 7562.
Lasteyrie, Charles Philibert de, his works on agriculture, page 1217. A. D. 1799.
Lastri, Proposto, his work on agriculture, page 1221. A. D. 1793.
 Latch for ornamental gates, 3090 ; the reversed, for gates, 3091.
Lathrop, E. L., Esq., his work on agriculture, page 1223. A. D. 1829.
Laurenc, Edward, his work on agriculture, page 1207. A. D. 1717.
 Lavender, culture of, 6179.
Lawrence, John, M. A., his work on agriculture, page 1207. A. D. 1726.
Lawrence, John, his works on agriculture, page 1211. A. D. 1796.
 Laws, Anglo-Saxon, respecting cattle, 196.
 Laws of pasturage among the ancient Welsh, 197.
Lawson, John, his work on agriculture, page 1211. A. D. 1797.
 Layers, annual, of perennials, 1573 ; concentric ligneous, of plants, structure of, 1373—1376 ; divergent ligneous, of plants, 1376 ; cortical, of plants, structure of, 1372.
 Laying out of landed estates, 3467.
 Lead mines in Dumfriesshire, 7839.
 Leaf, fall of the, 1718.
 Leaf of a plant, 1310.
 Leaf-collecting machine, Snowden's, 2730.
 Leaf-stalk of plants, 1358.
 Leases in Ireland, 823.
 Leases of farms, 4677 ; rents and covenants of, 4688.
 Leaping, the action of, in animals, 1905.
Leatham, Isaac, his work on agriculture, page 1210. A. D. 1794.
 Leaves of plants, anomalies in the, 1605.
 Leaves, reproduction of, when injured, 1681.
Le Brèze, his work on agriculture, page 1216. A. D. 1769.
Lebrocq, Philip, M. A., his work on agriculture, page 1210. A. D. 1793.
 Leech, the, 5905 ; the medicinal, 7620 ; food of, 7621 ; use of, 7622.
Légarré, J. D., Esq., his work on agriculture, page 1219. A. D. 1828.
 Leghorn manufacture of wheat straw, 5052.
 Leghorn plait, to imitate, with the culms of grass, 5766.
Legris, his work on agriculture, page 1218. A. D. 1825.
 Legumes, the cultivated, 5189.
 Leicestershire, statistics of, 7798.
 Leipsie, land near, 612.
 Leitrim, statistics of, 7885.
 Lentil, the, 5281 ; soil for, 5283 ; produce of, 5284 ; use of, 5285.
Lépinois, M. E. B. de, his work on agriculture, page 1219. A. D. 1826.
Lerouge, his work on agriculture, page 1216. A. D. 1774.
Lesbros-de-la-Versane, Louis, his work on agriculture, page 1215. A. D. 1768.
L'Etang de la-Salle, Simon Philibert de, his work on agriculture, page 1215. A. D. 1762.
Letellier, his work on agriculture, page 1214. A. D. 1602.
 Letters and papers on agriculture, planting, &c. Anon. page 1209. A. D. 1777—1816.
 Letting farms, 4671.
 Lettuce, the common Cos, 5513.
Leuchs, Char., his work on agriculture, page 1220. A. D. 1825.
 Level, the, 2497 ; Parker's, 2498 ; the common, 2499 ; the water, 2500 ; the American or triangular, 2501 ; the square, 2502 ; used in irrigation, 4393.
 Levelling, 3300.
 Levelling harrow, 2721.
 Levelling machine, the Flemish, 2720.
 Levelling staff, the, 2504.
 Lever, the, 2442.
Ley, Charles, his work on agriculture, page 1210. A. D. 1787.
 Library of Useful Knowledge, Farmer's Series. Anon. page 1214. A. D. 1830.
 Licence of rivers, 4359.
 Lichènes, utility of the, 1334.
Lichtervelde, J. F. de, his work on agriculture, page 7905.
 Life of animals, term of the, 1990 ; circumstances regulating the, 1991.
 Lifting, 3114.
 Ligaments of the bones, 1891.
Liger, Louis, his works on agriculture, page 1215. A. D. 1703.
 Light, as influencing agriculture, 1259 ; influence of, on the vital principle of vegetables, 1658—1762 ; regulation of, for plants, 1829 ; the nature of, 2325.
 Lightning, cause of, 2306 ; effects of, on trees, to remedy, 4033.
 Lilleshall estate of Lord Stafford, 7795.
 Lime, as a manure, 2284 ; effect of, on wheat crops, 2289 ; general principles for applying, 2290 ; promotes fermentation, 2291 ; phosphate of, as a manure, 2302.
 Lime in animals, 1930.
 Lime, burning, in heaps, 3862. 3870.
 Lime, and its management as a manure, 4970.
 Lime in plants, 1503.
 Lime, use of, in China, 1004.
 Lime-duster, the, 7700.
 Lime-kiln, Booker's, 3863 ; the Menteth or Closeburn, 3864 ; Heathorn's, 3868, a Yorkshire, 3869.
 Limerick, statistics of, 7879.
 Limestone, as a manure, 2292 ; magnesian, as a manure, 2294 ; test of magnesia in, 2295 ; machine for pounding, 2808. 3871.
 Lincolnshire, 7801.
 Line and plummet hygrometer, 2423.

- Line and reel, the, 2492.
 Line and reel used in irrigation, 4394.
 Lines, to lay out, on lands, 3316.
 Linlithgowshire. See West Lothian, 7845.
 Linseed-cake, as a manure, 2236.
 Liguorice, the, 6174; soil for, 6175.
 Lisle, Edward, Esq., his work on agriculture, page 1208. A. D. 1757.
 Lister, Martin, M.D. his work on agriculture, page 1207. A. D. 1683.
 Literature of English agriculture from the revolution, 801.
 Little, John, his work on agriculture, page 1213. A. D. 1815.
 Live stock, choice of, for the purposes of breeding or feeding, 4835.
 Live stock of Moldavia and Wallachia, 760.
 Live stock required for labour, 4828.
 Live stock of British agriculture, improvement of the, 786.
 Liver, to promote the growth of, in geese, 2087.
 Livy, Cav. his work on agriculture, page 1221. A. D. 1800.
 Loango, 1107.
 Lochleven, 7846.
 Lodges, agricultural, 7910.
 Lombardy, climate of, 262; soil of, 263; lands and landed property, 265, 266; irrigation of, 267; implements and operations of agriculture in, 268; cattle of, 269; dairies of, 270; sheep of, 271; rotations of crops in, 272; herbage crops in, 273; trees grown by the farmer in, 274.
 Londonderry, husbandry of, 811; statistics of, 7892.
 Longford, statistics of, 7874.
 Loochoo Islands, description of the, 1032.
 Losana, Matteo, his work on agriculture, page 1222. A. D. 1811.
 Loudon's Encyclopædie des Landwirthschaft. Anon. page 1220. A. D. 1826.
 Loudon's Hortus Britannicus, plants enumerated in, 1795.
 Loudon, John Claudius, F.L., G., Z., and H.S., his works on agriculture, page 1212. A. D. 1811.
 Louth, statistics of, 7875.
 Low, David, Esq., his work on agriculture, page 1213. A. D. 1823.
 Low's machine for raising large stones, 2810.
 Luccock, John, his works on agriculture, page 1212. A. D. 1805.
 Lucern, 5574; varieties, 5576; soil for, 5579; climate for, 5581; sowing, 5582; transplanting of, 5585; after culture of, 5586; top-dressings for, 5588; taking the crop of, 5589; application of, 5590; produce of, 5591; nutritive product of, 5592; saving the seed of, 5593; diseases of, 5594.
 Lüders, Ph. E., his work on agriculture, page 1219. A. D. 1769.
 Lullin, Ch. J. M., his work on agriculture, page 1218. A. D. 1806.
 Lumbert's mole-plough machinery, 2644.
 Lupine, the white, 5288.
 Lure, the, of the Swedish shepherd, 688.
 Lycopodineæ, 1329.
 Lycopodium complanatum as a dye, 698.
- M.
- M' Adam's opinion respecting the breadth of wheels for roads, 3735; system of repairing roads, 3763; theory and practice of road-making, 3581.
 Machine, Chinese, for pounding seeds, 995.
 Machine for reaping beans, Gladstone's, 2740; for reaping the heads of clover, 2741; for mowing clover hay, 2742.
 Machine for chopping cabbage, Newton's, 5508.
 Machinery, Lumbert's mole-plough, 2644.
 Machines for laying land level, 2719.
 Macirone, Colonel, his system of paving roads, 3721.
 Mackerel fishery, 3879.
 Mackintosh, Borland, his work on agriculture, page 1207. A. D. 1729.
 Macphail, James, his work on agriculture, page 1210. A. D. 1795.
 Macwilliam, Robert, Esq., his work on agriculture, page 1213. A. D. 1818.
 Madagascar, island of, 1141.
 Madder, 5949; soils for, 5950; planting, 5953; after-culture of, 5955; taking the crop of, 5956; drying the roots of, 5957; produce from the root, 5958; use of, 5960; collecting the seed of, 5961; diseases of, 5962; culture of, in the Netherlands, 486.
 Madeira cider, recipe for making, 4135.
 Madeira, island of, 1147; lands of, 1148; live stock of, 1151; fruits of, 1152.
 Magnesia, as a manure, 2304; in animals, 1931; in limestone, test of, 2295; in plants, 1505.
 Maidenhair tree, the, in China, 981.
 Main, J., his works on agriculture, page 1214. A. D. 1826—1831.
 Main, upper side of a, 4424.
 Maize, 5149; as a bread corn, 5150; varieties of, 5151; soil and climate for, 5152; culture of, 5153; sowing, 5155; mode of planting in America, 5156; transplanting, 5157; after-culture of, 5158; topping the plants of, 5159; harvesting, 5160; shelling or threshing, 5161; produce of, 5162; application of, 5163; diseases and enemies of, 5163; the Mexican process of sowing, 1183; of the West Indies, 1222.
 Maize-sheller, the, 2549.
 Malacca, agriculture of, 948.
 Malcolm, James, his work on agriculture, page 1212. A. D. 1805.
 Malcolm, William, James, and Jacob, their works on agriculture, page 1210. A. D. 1794.
 Malenotti, Ignazio, his work on agriculture, page 1222. A. D. 1815.
 Mallet, Robert Xavier, his work on agriculture, page 1216. A. D. 1780.
 Malt-dust, as a manure, 2235.
 Mammalia, noxious, 7624.
 Man, Isle of, statistics of, 7813.
 Management of landed property, 4624.
 Manager of an estate, and his assistants, 4627; duties of, 4658.
 Manganese, in animals, 1934.
 Manillas, the, or Philippine Islands, description of, 1030.
 Manna, the, of Calabria, 322.
 Manufactories, establishment of, 3843.
 Manufactory, evils of a populous, according to Marshal, 3844.
 Manures, 2224; animal and vegetable, 2227; organic, 2226; treatment of organic, 2231; application of, to pastures, 5822; of the Chinese, 1000—1008; collection of, in China, 999; curious source of, in Clackmannanshire, 7846; liquid, 2269; farm-yard, application of, in Scotland, 2276; in a recent state, 2275; organic, the management of, 2270; earthy and saline, 2279; fossil, 2283; season when it is applied, 4968.
 Manuring, origin of, 1826.
 Manurings, frequent, of the Flemish farmer, 494.
 Maps, delineation of, 3358; writing on, 3359.
 Marchand, Jean Henri, his work on agriculture, page 1215. A. D. 1768.
 Maremmes, the, in Italy, extent of the district of, 298; climate of, 299; surface of, 300; estates of, 301; agricultural implements and operations of, 302.
 Marine plants, 1745.
 Mariott's improved maize separator, 2550.
 Marjoram, culture of, 6180.
 Markets, situation of farm lands in regard to, 4773.
 Markham, Gervase, his works on agriculture, page 1207. A. D. 1613.
 Marking with the line, 3125.
 Marl as a manure, 2288.
 Marquesas Isles, the, 1058.
 Marshal's opinion on repairing roads, 3758.
 Marshall, William, Esq., his works on agriculture, page 1209. A. D. 1778.
 Marshes, fresh water, 4558; salt water, 4560; on the Thames, 4561; improvement of, 4557.
 Mascal Leonard, his works on agriculture, page 1206. A. D. 1581.
 Massachusetts Agricultural Repository and Journal. Anon. page 1223. A. D. 1825.
 Mastich, 1456.
 Mastiff, the, 7396.
 Materials for making roads, the best, 3635; preparation of, 3645.
 Materials of roads, depth of, 3664; order and mode of laying out the, 3684.
 Mather, John, his work on agriculture, page 1213. A. D. 1820.
 Matter, organised, of two kinds, 1836.
 Mattock, the, 2443.
 Maturity, early, advantage of, in live stock, 2027.
 Maunsell, William, L.L.D., his work on agriculture, page 1210. A. D. 1794.
 Maupin, his works on agriculture, page 1216. A. D. 1779.
 Mauritius, description of the, 1142.
 Maw seed, the, 6099.

- Maxims, agricultural, of the Romans, 157; of order and neatness, 3373.
- Maxwell*, Robert, his works on agriculture, page 1208. A. D. 1743.
- Mayet*, Etienne, his work on agriculture, page 1217. A. D. 1790.
- Mayo, statistics of, 7884.
- Mead, process of brewing, in Poland, 660.
- Meadow lands, 5768.
- Meadows*, Arthur, Esq., his work on agriculture, page 1214. A. D. 1828.
- Meadows, flowing, 4487; catch-work, 4428.
- Meadows, upland, 5772; culture of, 5774; manuring, 5781.
- Meager*, Leonard, his work on agriculture, page 1207. A. D. 1697.
- Mearns. See Kincardineshire, 7851.
- Measuring chain, the, 2505.
- Measuring of land, 3295; solid bodies, 3296; by the eye, 3297.
- Measuring rod, the, 2505.
- Meers, artificial, of Derbyshire, 4474.
- Meikle's* threshing machines, 2786—2791. 7782.
- Melons in Persia, 875.
- Membrana of plants, 1342.
- Mémoires d'Agriculture, &c. Anon. page 1219. A. D. 1828.
- Memoirs of the Board of Agriculture of the State of New York. Anon. page 1223. A. D. 1821—1826.
- Memoirs of the Philadelphia Society for promoting Agriculture. Anon. page 1223. A. D. 1785—1826.
- Méneser wine, 628.
- Merino sheep, introduction of, 790.
- Merinos of the Cape of Good Hope, 1128.
- Mesta, the, in Spain, 736.
- Metzger*, J., his work on agriculture, page 1220. A. D. 1826.
- Mexico, climate of, 1175; surface of, 1176; soil of, 1177; agriculture of, 1178; breeding of animals in, 1188; fruits of, 1190.
- Middle-men, the, in Ireland, 846.
- Middlesex, statistics of, 7771.
- Middleton*, John, Esq., his works on agriculture, page 1211. A. D. 1798.
- Midlothian, statistics of, 7833.
- Migration of animals, 2007.
- Mildew of plants, the, 1694.
- Mildew in wheat, 5065.
- Milestones, improved, 3723.
- Milk or cow farmers, 7732.
- Milking tasting of turnips, to improve, 7804.
- Mill, olive, in Spain, 727.
- Millet, 5174; the common, 5175; in China, 987; the German, 5176; the Italian, 5178; the Polish, 5179; the great or Indian, 5180; soil for, 5182; harvesting, 5183.
- Mills, establishment of, 3837.
- Mills*, John, F.R.S., his works on agriculture, page 1208. A. D. 1759.
- Mimosa nilótica, 1105.
- Mine-farmers, 7741.
- Mines, cautions respecting, 3873; methods of draining, 4273; prejudice against, as a species of property, 3853.
- Minnow, the, 7582.
- Mints, the culture of, 6182.
- Mistletoe, the, 1758.
- Mixture of fruits in cider-making, 4124.
- Mocaranga, description of, 1140.
- Models of mountainous estates, 3360.
- Moegelin, agricultural institution of, 576; Jacob's opinion of, 582.
- Moisture, influence of, on lands, 1264; regulation of, for plants, 1828; natural to vegetables, 1738.
- Moldavia, agriculture of, 759.
- Mole, the, 7631.
- Moleon*, J. G. V. de, his work on agriculture, page 1219. A. D. 1829.
- Mole-traps, 2581.
- Moluccas, or Spice Islands, description of the, 1033.
- Mommon's invention for guiding the operation of boring, 4498.
- Monaghan, statistics of, 7889.
- Monk*, John, his works on agriculture, page 1210. A. D. 1794.
- Monmouthshire, statistics of, 7793.
- Monocotyledonæ, distribution, 1779.
- Monteath*, Robert, his work on agriculture, page 1213. A. D. 1820.
- Montcith's* directions for making trees crooked, 4001.
- Months, the hottest and coldest, 2436.
- Moon, influence of, on the weather, 2402.
- Moore*, Sir Jonas, Knight, F.R.S., his works on agriculture, page 1207. A. D. 1685.
- Moors, agriculture among the, 114.
- Moors, improvement of, 4538.
- Morasses, improvement of, 4541.
- Moravia, favourable state of, for agriculture, 626.
- Morayshire, statistics of, 7853.
- Mordant*, John, his work on agriculture, page 1208. A. D. 1761.
- Morea, agricultural circumstances of the, 752; plough of the, 752; figs of the, 753; oxen of the, 755; forests of the, 756.
- Morel de Vindé*, his works on agriculture, page 1218. A. D. 1807.
- Moretti*, Dr. G., his work on agriculture, page 1222. A. D. 1826.
- Morice*, Francis, his work on agriculture, page 1213. A. D. 1824.
- Morley*, Christopher, his work on agriculture, page 1211. A. D. 1797.
- Morocco, description of the empire of, 1098; mode of enriching the land of, 1099; the live stock of, 1100.
- Morogues* Baron de, his work on agriculture, page 1218. A. D. 1822.
- Mortemart-Boisse*, his work on agriculture, page 1218. A. D. 1824.
- Mortimer*, John, his work on agriculture, page 1207. A. D. 1707.
- Moss of Kincardine, the, 2183; manner of floating off, 2184.
- Mosses on pastures, to prevent the growth of, 5920.
- Motions, muscular, of animals, 1898.
- Moubray*, Bonnington, Esq., his work on agriculture, page 1213. A. D. 1815.
- Mouldebaert, the, 508.
- Mound, the earthen, 4340; with puddle-wall embankment, the, 4346.
- Mound faced with stones, 4349.
- Mounds with reversed slopes, 4348; protected by a wicker hedge, 4351.
- Mount Annan, in Dumfriesshire, improvement of, 7839.
- Mountains, improvement of, 4513.
- Mouse, the long-tailed field, and the short-tailed field, 7637; in the forest of Dean, 7638.
- Mowing, 3166; the Hainault, 3172.
- Mowing and feed alternately, 5813.
- Mucus in animals, 1944.
- Mud walls for cottages, 2894.
- Mulberry tree in China, 983; in Hindustan, 897; the white, in Spain, 730.
- Mules of Persia, 872.
- Munro*, Col. Innes, his work on agriculture, page 1213. A. D. 1822.
- Músci, 1330.
- Muscles, the, of animals, 1892; functions of, 1894.
- Museum Rusticum et Commerciale, &c. Anon. page 1208. A. D. 1763.
- Mustard, the white and black, 6103; soil for, 6105; reaping of, 6106; use of, 6107; substitutes for, 6110.
- Myrrh, 1481.
- Myrtle, wax of, 1452.

N.

- Nails of animals, 1865.
- Nairnshire, statistics of, 7853, 7854.
- Naismith*, John, his works on agriculture, page 1210. A. D. 1790.
- Names of plants, rules in forming the, 1297.
- Nan*, Bh. Seb., his work on agriculture, page 1219. A. D. 1791.
- Napier*, Hon. William John, F.R.S., his work on agriculture, page 1213. A. D. 1822.
- Narcotic principle, the, in vegetables, 1422.
- Neapolitan territory, the farming on the, 312; me-tayers of, 313; trees of, 314; maize of, 315; plants and fruit of, 318—324; oysters of, 325.
- Neat cattle, see horned cattle, 6773.
- Neatness, 3372.
- Nelumbium, the, of China, 985.
- Nervous system in animals, the, 1912; functions of the, 1915.
- Netherlands, present state of agriculture in the, 429; idea of husbandry in, 431; political secret of husbandry in, 432; present state of agriculture in, 433; climate of, 434; surface of, 435; confusion of the Dutch and Flemish, 436; landed property of, 437; farmeries of the, 438; a farmery of the, 439; arable lands of, 442; fallows in, 443; soil and culture of, 444; the polders or embanked

- lands of, 447; culture of the polder of Snaerskirke in, 448; reclaiming lands in, 449; mills for raising water in, 451; cultivation of some particular crops in, 460; wheat in, 461; rye in, 462; buck-wheat, 463; rape, 464; cultivation of the poppy, 467; the red clover, 470; the turnip, 471; the potato in, 472; the carrot in, 474; the white beet in, 476; manufacturing beet-root sugar in, 478; culture of flax in, 479; culture of spurry in, 482; culture of the hop in, 484; culture of madder in, 486; culture of woad in, 491; culinary vegetables of, 492; treatment of asparagus in, 493; manures in use in, 495; agricultural implements of, 505; plough of, 506; agricultural operations in, 515; trenching in, 516; live stock in, 517; the horse of, 518; dairies of, 523; woodlands of, 526; artificial plantations in, 527; the pine woods of, 529; preservation of trees in, 532; royal forests of, 533; management of the coppices in, 536; sorts of trees cultivated in, 537; domestic circumstances of the farmers of, 538; farm servants of, 540; day labourers of, 541; beggars of, 542; clothing of the peasantry of, 543; farm-houses of, 544; labourer's cottage of, 545; character of the farmers of, 546.
- Neuve-Eglise*, Louis Joseph Bellepière de, his works on agriculture, page 1215. A. D. 1761.
- New Britain, agriculture of, 1052.
- New Brunswick, agriculture of, 1195.
- New Caledonia, agriculture of, 1052.
- New Guinea, agriculture of, 1053.
- New Hebrides, the, agriculture of, 1052.
- New Holland, as a country for emigrants, 1036; general account of, 1037; mineral productions of, 1038; soil of, 1039; the productions of nature in, 1040; state of cultivation in, 1041.
- New Ireland, agriculture of, 1052.
- New South Wales, as a country for agricultural emigrants, 1042.
- New York Farmer and Horticultural Repository. Anon. page 1228. A. D. 1828.
- New Zealand, agriculture of, 1054.
- Newstead farmery, 4165.
- Nicole's mode of distilling palatable water at sea, 4510.
- Night soil, as a manure, 2259.
- Nitre, as a manure, 2307.
- Norfolk, statistics of, 7788.
- Normandy, climate of, 392.
- North America, climate of, 1153; surface of, 1154; agriculture of, 1155.
- Northamptonshire, statistics of, 7803.
- Northumberland, statistics of, 7809.
- Northumberland ploughman the happiest of labourers, 7962.
- Norway, climate of, 687; cottages in, 693; domestic customs of the farmers in, 707.
- Norwegians, Alpine, habits of the, 1260.
- Nottinghamshire, statistics of, 7800.
- Nourishment, abundant, necessary to produce a perfect-formed animal, 2051.
- Nurse*, Timothy, his work on agriculture, page 1207. A. D. 1700.
- Nova Scotia, 1195.
- Nubia, 1091.
- Nucleus of the seed of plants, 1343.
- Nutmeg tree, description of the, 1033.
- Nutshell of plants, 1353.
- O.
- Oak trees, valuing of, 4074.
- Oat, the, in China, 980; varieties of, 5121; soil for, 5134; climate for, 5136; sowing, 5139; after-culture of, 5140; harvesting, 5141; kiln-drying, 5142; produce of, 5144; use of, 5146; diseases of, 5147.
- Oatmeal, remarks on, as a principal food, 7850.
- Oats, frosted, 4997.
- Oats, insects injurious to, 7664.
- Object staff, the, 2503.
- Objects, organised or unorganised, 1290.
- Obstacles in hedge-making, to avert, 3005.
- Odometer, the, 2506.
- Ogle's machine for reaping and sheaving corn, 2739.
- Oil, olive, 1436; of almonds, 1437; rape-seed, 1438; of behen, 1439; linseed, 1441; nut, 1442; poppy, 1443; hempseed, 1444.
- Oil plants, 6074—6098; cultivated in France, 6101.
- Oil of vitriol, as an hygrometer, 2421.
- Oil-cake bruiser, 1554.
- Oils, animal, 1947; the properties of, 1952.
- Oils, vegetable, fixed, 1434; fat, 1435; drying, 1440; volatile, 1445.
- Olibanum, 1478.
- Olive, the, in Spain, 727.
- Olive tree of the Morea, 752.
- Onorati*, Nicola Columella, his works on agriculture, page 1222. A. D. 1816.
- Operations of husbandry after the Norman conquest, 207.
- Operators on farms, gradation of, 3368.
- Opobalsamum, 1461.
- Opoanax, 1476.
- Orchard, the, 2917.
- Orchard farmers, 7730.
- Orchard fruits, Gibbs's select list of, 4097.
- Orchards, choosing trees for, 4105.
- Orchards in Clydesdale, 7842.
- Orchards, formation of, 4079; aspect, soil, and situation for, 4081; sorts of trees for, 4085; manner of planting, 4106; after-management of, 4110; gathering and keeping the fruit of, 4120.
- Orchis, the culture of, 6184.
- Order and neatness, necessity of, 3370; maxims of, 3373.
- Organs, decomposite, of plants, development of, 1580.
- Orkney Islands, statistics of the, 7860.
- Orobánche, the, 1760.
- Osier grounds, produce of, 4042.
- Otaheite Island, 1061; soil of the, 1062; produce of the, 1063; live stock of the, 1064.
- Otter, the, an enemy to fish, 3891.
- Ovary, fecundation of the, 1627.
- Oven, a baking or roasting, 2807.
- Overseer of slaves in Jamaica, 1201; his house, 1205.
- Ox, see horned cattle, 6773.
- Ox, the common, of Hindustan, 912; of Thibet, 882; of the Morea, 755.
- Oxfordshire, statistics of, 7789.
- Oxides, metallic, in vegetable ashes, 1507.
- Oxygen, in animals, 1920.
- Oxygen, in the atmosphere, 2341; use of, to vegetables and animals, 2342.
- Oyster fishery, 3884.
- Oysters of the kingdom of Naples, 325.
- P.
- Pail, the, 2528.
- Paillet*, his work on agriculture, page 1217. A. D. 1791.
- Palm, the areca, of Sumatra, 1025; the fan, in Spain, 725.
- Palm trees in Hindustan, 901.
- Palmyra, the, of Hindustan, 906.
- Palk*, Sir Lawrence, a new village seaport in Devonshire formed by, 3852.
- Paling fences, 3039.
- Paling, the simple nailed, 3040; the jointed horizontal, 3041; the upright lath, 3042; the horizontal, of young firs, &c., 3043.
- Palteau*, Guillaume Louis Formanoir de, his work on agriculture, page 1215. A. D. 1768.
- Pane of ground, 4415.
- Pane, upper, in a meadow, 4425.
- Paraguay, description of, 1231.
- Paring and burning lands, 3209.
- Paring lands, 4536.
- Park, extent of, on an estate, 3517.
- Park-gate, the improved, 3097; Parker's sympathetic, 3107.
- Parks, number of, in the time of Elizabeth, 225.
- Parkinson*, Richard, his works on agriculture, page 1211. A. D. 1799.
- Parlof*, M., his work on agriculture, 7907.
- Parmentier*, Antoine Augustin, his works on agriculture, page 1216. A. D. 1781.
- Parry*, Caleb Hillier, M. D. F. R. S., his works on agriculture, page 1211. A. D. 1800.
- Parsley, 5634.
- Parsnep, 5471; best variety of, 5472; soil, preparation, and manure, 5473; sowing, 5474; after-culture, and taking up, 5477; produce of, 5478; use of, 5480; saving the seed of, 5481.
- Partridge, the, 7556.
- Pastures, the best natural, of England, plants composing, 5703; feeding, 5816; culture and management of, 5817; hilly, 5839; improving, without taking a crop of corn, 5844; insects injurious to, 7676; mountainous, 5842; improvement of, 5845; permanent, 5815; permanent, lands best adapted for, 5851; old, to regenerate, 5843; upland, management of, 5840; weeding of, 5818; stocking, 5825.

- Patagonia, agriculture of, 1245.
Paterson's opinion of broad wheels, 3732; of M'Adam's road-making, 3593; of the breadth of road, 3599, his system of draining roads, 3604; his system of repairing roads, 3760.
 Patrons of agriculture, 7759; improving the taste of, 7929.
Paupaille, M., his work on agriculture, page 1219. A. D. 1826.
 Pavement, defects of the common, and theory of its wear, 3716.
 Pavements, 3696; improvements in laying, 3713.
 Paving roads, 3697.
Payen et Chevalier, MM., their works on agriculture, page 1219. A. D. 1825.
 Pea, the, 5191; varieties of, 5192; choice of sorts, 5196; soil for the, 5198; climate of the, 5199; sowing the, 5200; after-culture of the, 5206; harvesting, 5207; threshing, 5211; produce of the, 5212; use of, 5216; saving the, 5220; diseases of the, 5221.
 Pea-straw, use of, 5219.
 Peacock, the 7495.
 Pears, baking and dessert, fit for orchards, according to Nicol, 4093; to Gorrie, 4094; to Gibbs, 4097.
 Pears, cider, the most approved sorts of, 4091.
Pearson, George, M.D. F.R.S., his work on agriculture, page 1212. A. D. 1805.
Pearson's select list of orchard apples, 4099.
 Peas, insects injurious to, 7665.
 Peat ashes as a manure in Berkshire, 7790.
 Peat-borer, the, 2519.
 Peat-burning, 3210.
 Peat mosses, improvement of, 4541.
 Peaty matter, as a manure, 2241.
 Peebleshire, statistics of, 7838.
 Pellew Isles, agriculture of, 1056.
 People, character of a, as influencing agriculture, 1274.
 Pepper, the intoxicating, of Borneo, 1029.
 Pepper plant of Sumatra, 1022.
 Perch, 7578.
 Perennials, and their annual layers, 1573.
 Pericarp of plants, 1349.
 Periodicals, agricultural, 805.
 Periosteum of the bone, 1882.
 Perry, manufacture of, 436; produce of, by the acre, 4137.
 Perthshire, statistics of, 7849.
 Persia, climate of, 863; surface of, 864; soil of, 865; landed property of, 866; agricultural products of, 867; fruits of, 869; saline deserts of, 870; live stock of, 871; mode of hunting the quail in, 873; implements and operations of agriculture in, 874; artificial watering in, 876; forests of, 877.
 Perspective, isometrical, 3365.
 Peru, agriculture of, 1228.
Peters, Matthew, his works on agriculture, page 1209. A. D. 1770.
 Petsai, the, a species of white cabbage, of China, 988.
Peyrouse, Baron Picot de la, his work on agriculture, page 1218. A. D. 1819.
 Pheasant, the common, 7548; varieties of, 7550; breeding, 7551; feeding, 7554.
Phillips, Robert, his work on agriculture, page 1208. A. D. 1737.
 Phœnicia, agriculture of, 37.
 Phosphate of lime, as a manure, 2302.
 Phosphorus in animals, 1922.
 Phytography, 1925.
Piacenza, Giovanni, his work on agriculture, page 1221. A. D. 1805.
 Picardy, climate of, 392.
 Pick, the, 2443.
 Picking, 3122.
 Pickling wheat for sowing, 5026.
Pictet, Charles, his works on agriculture, page 1217. A. D. 1802.
 Piers, caution requisite in the use of, 4364; construction of, 4365.
 Pigeon, the, 7532; flesh of, 7533; varieties of, 7535; breeding, 7537; terms applied to, 7538; food of, 7539; cleanliness of, 7541; diseases of, 7546; laws respecting, 7547.
 Pigeon's dung, as a manure, 2260; use of the, in Persia, 875.
 Pigeon-houses, 7542; the interior of, 7543; breeding holes in, 7544.
 Pigeonry, the, 2844.
 Pig-house, Harley's, 2839.
 Pigs of the Cape of Good Hope, 1131.
 Pike, 7580.
 Pilchard fishery, 3882.
 Pine plantations, management of, 4017.
Pinteur, his work on agriculture, page 1219. A. D. 1825.
 Pipe-draining, Pearson's method of, 4297.
 Pitch, 1455.
 Pith of plants, structure of the, 1371.
 Pithing cattle, 2092; Du Gard's observations on, 2093.
 Pits, method of draining, 4274.
Pitt, William, his works on agriculture, page 1210. A. D. 1794.
 Pitting system of planting, 3945. 3951.
 Plaiting straw, 5056.
 Plan of life, necessity of forming a, 7954.
 Plans of estates, to make, 3351.
 Plantain, the, culture of, in the West Indies, 1218.
 Plantations, as skreens on farms, 4585; filling up blanks in, 3983; pruning and heading down trees in, 3987; the formation of, 3922; enclosing, 3923; preparation of the soil for, 3924; whether should be sown or planted, 3926; disposing the plants in, 3928; mixture of trees in, 3958; insects injurious to, 7681; near roads, 3621; neglected, improvement of, 4022; for shelter, 4585; of spruce and silver firs, management of, 4018; thinning out, 4009; the proper season for, 4020.
 Planting, 3142; as applied to seeds and tubers, 3143; as applied to plants already originated, 3144.
 Planting trees, a general principle of guidance in, 3910; the fittest situations for, 3911; near buildings, 3913; sort of product desired from, 3921; orchard trees, 4106; seasons for, 3937; with the diamond dibber, 3948; with the planting mattock, 3949; with the forest planter or ground adze, 3950.
 Plants, action of the atmosphere on, 2344; of Brazil, with fibres adapted for economic purposes, 1236; of Britain, distribution of, 1795; social and anti-social habits of, 1772; colouring, 5995; composite organs of, 1368. 1568; elementary organs of, 1378. 1566; conservative appendages of, 1312; conservative organs of, 1306; constituent elements of, 1510; cotyledonous and acotyledonous, of Britain, 1797, 1798; distribution of, 1799, 1800; geographical distribution of, 1801; cultivated for oil in Hindustan, 900; cultivated for their roots or leaves, 5289; nutritive products of, 5290; cultivated for their use in the brewery, 5996; substitutes for, 6072; definition of, 1670; diseases of, 1685; distribution of, with respect to their systematic classifications, 1776; food of, 1521; general distribution of, 1722; green succulent, as a manure, 2233; herbage, 5518; Sir H. Davy's table of the nutritive products of the principal, 5520; imperfect, 1328; to increase the number and improve the nutritive qualities of, 1825; injuries and disorders incident to, 1671; introsusception of nourishment by, 1538; maritime, 1748; fluvial, 1749; champaign, 1750; dumose, 1751; ruderate, 1752; sylvatic, 1753; alpine, 1754; parasitical, 1755; domesticated, 1765; mode of describing, 1299; the most universal, 1782; the native countries of, 1774; natural decline of, 1716; decay of the temporary organs in, 1717; decay of the permanent organs of, 1721; physical virtues of, changed by cultivation, 1620; preparation of, for planting, 3145; insertion of, in the prepared soil, 3146; reproductive organs of, 1321; appendages of the, 1327; the total number of species of, 1794; the true nourishment of, 2147; the two methods of arranging, 1302; useful and edible, of China, 989; virtues of, where resident, 1497; of visible sexes, 1777; of invisible sexes, 1778; which distinguish the various kinds of soils, 2122.
 Plashing an old hedge, 3025.
Plat, Hugh, his work on agriculture, page 1207. A. D. 1601.
Plattes, Gabriel, his works on agriculture, page 1207. A. D. 1639.
 Plough, Arabian. 885; the common, of Castile, 744; the Chinese, 995; draining, 2626; wheel, 2627; of Ezerum, 874; forms of the different parts of, 2591; at Moegelin, 588; of the Morea, 752; of Osterbothnia, 703; the Walloon, 507; Weatherley's movable stilt, 2612; the ribbing, 2612; Duckett's skim coulter, 2613; the double share, 2615; the mining or trenching, 2616; Somerville's double furrow, 2617; the Argyleshire, 2618; the

- double mould-boarded, 2619; the binot, 2620; the marking, 2621; Clymer's, 2622; Stothard's, 2623; Morton's trenching, 2624; Gladstone's water-furrowing, 2625; the improved Scotch, with one or two wheels, 2629; the Beverston, 2630; the Norfolk wheel, 2632; Wilkie's single-horse wheel, 2634; Wilkie's improved friction-wheel, 2637; the paring wheel, 2638; Clarke's draining, 2639; Merton's draining, 2641; the gutter, 2642; the mole, 2643; the Duke of Bridgewater's draining, 2646; the pressing, 2648; Wilkie's wheel, with a shifting muzzle, 7843; wheel and swing, 2587; construction of, 2588; materials of, 2597; turn-wrest swing, 2609; the Scotch swing, 2598; the Scotch, 2600; Small's, 2601; the Northumberland and Berwickshire, 2602; Wilkie's swing, 2603; Finlayson's iron, 2604; the heath, or self-cleaning, 2605; Finlayson's Kentish skeleton self-cleaning, 2606; Finlayson's line, 2607; the Somerville swing, 2608; Gray's turn-wrest swing, 2610.
- Ploughboy, Anon. page 1223. A. D. 1826.
- Ploughing, 3239; shallow, 3247; steep lands, 3254; relative to time, 3257; relative to season, 3258.
- Ploughing in wheat, 5031.
- Ploughman, choice of, 4868; plan of maintaining in the best cultivated districts of Scotland, 4870; slowness of, in some districts, 4881.
- Ploughman, a good one described, 33.
- Ploughman, head, 7716.
- Plucknet's* attempt at a reaping-machine, 2733.
- Plum, the, well deserving of cultivation, 4100.
- Plums, baking, the best sorts of, for an orchard, 4095.
- Plums, culture of, in Austria, 629.
- Plums, dessert, for an orchard, 4096.
- Plumule of plants, 1348.
- Poaching salmon, 3901.
- Pocket-rule, the, 2505.
- Pointer, the, 7399.
- Poison tree of Java, 946.
- Poland, present agriculture of, 641; landed estates in, 642; houses of the noble postmasters in, 642; climate of, 644; surface of, 645; soil of, 646; the southern part of, 647; the landed estates of the vice-regal portion of, 649; the cultivators, 650; arable culture of, 651; implements and operations of agriculture in, 652; the live stock of, 653; the forests of, 654; management of bees in, 655; improvements in the agriculture of, since 1814, 662.
- Pole-cat, the, 7628.
- Police, professional, relative to agriculture, 7909.
- Polignac*, Comte Charles de, his work on agriculture, page 1218. A. D. 1822.
- Political circumstances, as influencing agriculture, 1272.
- Pollard-trees, 4055.
- Potoncau*, M., his work on agriculture, page 1218. A. D. 1824.
- Pond, a, 4421.
- Ponds for collecting rain water, mode of constructing, 4467; the Gloucestershire, 4473; method of draining, 4275.
- Pontey's* methods of planting, 3952; opinion on pruning, 3989.
- Pontier*, P. H., his work on agriculture, page 1219. A. D. 1826.
- Pool-fishing, 3903.
- Poppy, the, in Hindustan, 898; the small or field, as an oil plant, 6099.
- Pores of plants, 1388.
- Porpoise, the, an enemy to fish, 3893.
- Porta*, J. B., his work on agriculture, page 1219. A. D. 1592.
- Portraying of rural objects, 3347.
- Portugal, agricultural circumstances of, 749.
- Pot tree, the, of Brazil, 1235.
- Potash in animals, 1927.
- Potato, the, 5921; as human food, 5295; value of, as a fallow crop, 5298; varieties of the, 5300; soil for, 5307; climate for, 5310; season for planting, 5311; preparing the sets of, 5312; modes of planting, 5316; after-culture of, 5327; taking of the crop of, 5338; storing and preserving, 5342; produce of, 5348; application of, 5349; the extraordinary applications of, 5361; application of, as food for live stock, 5365; machine for washing, 5367; the boiling of, 5368; frosted, 5369; diseases of, 5370.
- Potato cleaner, the, 2547.
- Potato dibber, 2470.
- Potato scoop, Edinburgh, 2494.
- Potatoes, introduction of, 238; of Ireland, 838; in Spain, 726.
- Potato-set scoop, the, 2493.
- Potato-weighing machine, 2569.
- Poultry. See Cock and Hen, 7439.
- Poultry farmers, 7727.
- Poultry-house, interior arrangement of the, 2842.
- Poultry houses, 2840. 7431; furniture or fixtures of, 7434; utensils of, 7437; at Winnington, Lord Penrhyn's, 7814.
- Poultry-yard, 2914.
- Power requisite to estimate, 3320.
- Préau-deau-Chemilly*, Eugene, his work on agriculture, page 1217. A. D. 1794.
- Préfontaine*, his work on agriculture, page 1215. A. D. 1763.
- Pressing plough, the, 2714.
- Prevost*, Bénédicte, his work on agriculture, page 1218. A. D. 1807.
- Prévôt de Rivolta*, his work on agriculture, page 1222. A. D. 1826.
- Prize essays, and Transactions of the Highland Society of Scotland. Anon. page 1211. A. D. 1799—1830.
- Professor of agricultural science, the, 7758.
- Professorships of agriculture, 806; public, 7924.
- Profit of the Roman farmers, 168.
- Profits to which a farmer is entitled, 4799.
- Propagation by seeds, 1641; by gems, 1646; by leaves, 1649; by runners, 1650; by slips, 1651; by layers, 1652; by suckers, 1653; by grafting and budding, 1654.
- Propagation of the species of plants, causes limiting, 1655.
- Propago of plants, 1362.
- Property, landed, in England, the different kinds and tenures of, 3388; in Scotland, 3400; in Ireland, 3406; valuation of, 3408; purchase or transfer of, 3455; consolidation of, 3471.
- Propriety, 3371.
- Pruning, 3158; objects of, 3159; for promoting the growth and bulk of a tree, 3160; for lessening the bulk of a tree, 3161; for modifying the form of the tree, 3162; for adjusting the stem and branches to the roots, 3163; for renewal of the head, 3164; for curing diseases, 3165; coppice woods, 4003; deciduous trees, 3997; effect of, on timber trees, 3972; frondose or resinous trees, 3988; hedges, 4005; hedge-row trees, 4006; orchard trees, 4111; trees, 1677; the manner of, 3993; plantations, 3989; the general seasons of, 3994; implements necessary for, 3996.
- Prussia, improvements in the agriculture of, 567. 575; surface and soil of, 568; soil of the maritime provinces of, 569; landed estates in, 570; general course of cultivation in, 571; live stock of, 572; implements of husbandry of, 573; produce of the soil of, 574; culture of the vine in, 590; good effected by the present king of, 591.
- Pubescence of plants, 1319.
- Puddling canals, 3824.
- Puddling, 3827; history of, 3829.
- Pulling crops, 3181.
- Pulp of plants, structure of the, 1370.
- Pulverisation of soils, 2163.
- Pumps for raising water, 4500.
- Purchase of landed property, 3455.
- Pushing, 3117.
- Putin*, Charles, his work on agriculture, page 1215. A. D. 1663.
- Puwis*, M. A., his work on agriculture, page 1219. A. D. 1826.
- Pyrites, use of, in burning clay, 3228.

Q.

- Quail, the, 7558; Persian mode of hunting, 873.
- Quarries, method of draining, 4274; working of, 3861.
- Quarterly Journal of Agriculture, Anon. page 1214. A. D. 1828—1831.
- Queen's county, statistics of, 7870.
- Quercus Süber, in Spain, 747.
- Quinquina, extract of, 1411.

R.

- Rabbit, the, 7341; warrens of the, 7343; varieties of, for stocking warrens, 7346; breeding and rearing of, 7351. 7356; the Angora, 7354; feeding, 7357; flesh of, 7359; diseases, 7363.
- Rabbitry, the, 2843.
- Rabbit's dung, as a manure, 2262.

- Radcliffe*, Rev. T., his work on agriculture, page 1213. A. D. 1819.
- Rags, woollen, as a manure, 2250.
- Rail-roads, 3543.
- Railways, 3785; advantage of, 3791; forming and constructing, 3792; of stone, Matthews's, 3703.
- Rain, 2367; phenomena of, 2368; cause of, 2369; monthly and annual quantities of, 2372.
- Rain-gauge, use of the, 2426.
- Rain water, collecting, from roads in ponds, 4465.
- Rake, the, 2449; the horse or stubble, 2725; the couch-grass, 2726; Weir's improved hay or corn, 2727.
- Raking machines, 2723.
- Ramenta of plants, 1317.
- Randall*, J., his works on agriculture, page 1208. A. D. 1764.
- Rape, 6075; soils for, 6079; sowing, 6083; transplanting, 6085; after-culture of, 6087; harvesting, 6089; produce of, 6091; uses of, 6092.
- Rape-cake, as a manure, 2234.
- Raspberry as an orchard fruit, 4104.
- Rat, the domestic or Norway, 7632.
- Rattery, Paul of Starston's, 7634.
- Rat-traps, 2581.
- Rauch*, F. A., his work on agriculture, page 1217. A. D. 1802.
- Re*, Filippo, his works on agriculture, page 1221. A. D. 1808.
- Réaumur*, René, Antoine Ferchault, sieur de, his work on agriculture, page 1215. A. D. 1749.
- Reaping, 3173. 3178; by the acre, 3180; wheat, 5043.
- Reaping-hook, the, 2481; the smooth, 2482; Hut-ton's improved, 2483.
- Reaping machines, 2731. & 2737.
- Reaping machines, 2731.
- Rearing domestic animals, 2066.
- Receptacle of plants, 1324.
- Recollection of surfaces and of country of great interest to the agriculturist, 3298.
- Redolfi*, Cosimo, his work on agriculture, page 1222. A. D. 1818.
- Reds, vegetable, for dyeing, 1416.
- Reed, method of thatching with, 3190.
- Reider*, T., his work on agriculture, page 1220. A. D. 1825.
- Rein-deer, the, 7361.
- Religion, as influencing agriculture, 1273.
- Renné*, George, Esq., his work on agriculture, page 1210. A. D. 1794.
- Rent of grazing farms, 4796; of land among the Anglo-Saxons, 202; in Scotland, 4795; in England, 4797.
- Rents of landed estates, receiving of, 4702.
- Rents of leases, 4688.
- Repairs in drains, 4266.
- Reproduction in animals, 1972.
- Resin, Botany Bay, 1467; green, 1466.
- Resins, vegetable, 1453; use of, 1471.
- Rhubarb, 6176; culture of, 6177; Chinese mode of curing, 6178.
- Ribbe*, M., his work on agriculture, page 1220. A. D. 1826.
- Ribbing, 3255.
- Ribbing wheat, 5033.
- Ribworm, plaitain, the, 5625.
- Ricci* Jacopo, his works on agriculture, page 1222. A. D. 1816.
- Rice, 5185; cultivation of, in Egypt, 1078.
- Richards*, John, his work on agriculture, page 1207. A. D. 1730.
- Richardson's* machine for raising large stones, 4523.
- Richter*, K. F., his works on agriculture, page 1220. A. D. 1804.
- Ricinus communis*, 862. 978.
- Ricking of corn, 3176.
- Rick-stand, Waistell's circular, 2909.
- Ridder, the, an addition to the plough, 7848.
- Ridges, 3249; on dry, porous, turnip soils, 3250; mode of forming straight, and of uniform breadth, 3251; the direction and length of, 3253; in Buckinghamshire, 7783.
- Ridging, 3127.
- Rid-plough, Finlayson's, 4540.
- Riem*, his work on agriculture, page 1216, A. D. 1770.
- Riem*, J., his works on agriculture, page 1220. A. D. 1792.
- Rigaud de l'Isle*, his work on agriculture, page 1216. A. D. 1759.
- Rigby*, Edward, M. D., F. L. S., his works on agriculture, page 1213. A. D. 1820.
- Rein-deer moss, 696.
- Rippling, 3204.
- Rippling flax, 5899.
- River farmers, 7742.
- River-meadows, 5769.
- River plants, 1745.
- Rivers, altering the course of, 4371; a common cause of injury to the banks of, 4362; the natural licence of, 4359; operations for improving, 4360; raising to a higher level, 4377; sometimes injurious to lands, 2202.
- Rückert*, G. Ch. Alb., his work on agriculture, page 1220. A. D. 1800.
- Roads, the best materials for making, 3635.
- Roads, breadth of, 3595; ought to be wide and strong, 3597; narrow, 3601; drainage of, 3602.
- Road-bridges, 3611.
- Roads, concave, 3670; convex, 3671; semi-convex, 3674; advantage of good, 3523; M'Adam's plan of making, 3527; paving of, 3697; junction of, 3620; laying out over a hill, 3559; direction of, through an extensive estate, 3562; machine for scraping, 3749; machine for sweeping, 3751; Biddle's machine for repairing, 3757; arrangement of, on farms, 4210; national, 3530; parochial, 3531; of estates, 3533; of farms, 3594; paved, 3538; planked, 3542; the laying out of, 3545; the line of direction in, 3547; on an inclined plane, 7812; preparation of the base of, 3622; preservation of, 3727; repair of, 3744; the proper degree of convexity for, 3676; proper width of, 3566; strength of, 3567; durability of, 3569; smoothness of, 3570; wear or decay of, 3571; washing, 3754; Paterson's system of repairing, 3760; M'Adam's system of repairing, 3763.
- Road embankments, 3611.
- Road fences, 3617.
- Road-harrow, Harriott's, 3745.
- Road-making, M'Adam's theory and practice of, 3581.
- Robertson*, George, his works on agriculture, page 1210. A. D. 1795.
- Robertson*, James, D. D., his works on agriculture, page 1211. A. D. 1799.
- Rocca*, Abbé Della, his work on agriculture, page 1221. A. D. 1790.
- Roccella tinctoria*, as a scarlet dye, 697.
- Rocks, improvement of, 4517; primitive, 2102; of transition, 2103; floetz, 2104; volcanic, 2106; relative situation of, in Britain, 2107; how converted into soils, 2111.
- Rocks or stones, modes of rending, by gunpowder, 4524.
- Roe, the, 7371.
- Roller, the, 2707; the parted cast-iron, 2708; the spiky or compound, 2709; the only essential, 2717.
- Roller and water box, 2711.
- Rolling, 3269.
- Rolling newly laid on road metals, 3694.
- Rolling roads, 3755; Telford's directions for repairing, 3774; the best seasons for repairing, 3780.
- Roman authors, 44; Cato, 45; Varro, 46; Virgil, 47; Columella, 48; Pliny the elder, 49; Palladius, 50.
- Romans, ass, use of, among the, 105; mules, 106; horse, 108; dog, 108; plough of the Romans, 110; wheel ploughs, invention of, 113; brake, 114; hoes, 117—119; spade, 120; instruments, Roman 114—123; reaping hook, 123; ploughing, among the Romans, 127; fallowing, 128; manuring, 129; marl, 130; sowing, among the Romans, 131; reaping, 132; reaping machine, Roman, 133.
- Romans, culture and farm management of the, 71; farm, choice of one, directed, 72; soil, 74; villa, origin of the, 75; position of a, 80; divided into three parts, 81; servants, agricultural, 85; bailiff, 86; ploughman, Roman, requisites of a, 88; wages in agriculture amongst the Romans, 89; beasts of labour used by the Romans, 93; breeding of cattle, 93; training cattle, 98; oxen, how fed and used, 100; direction for purchasing, 104; threshing, 135; winnowing, 137; hay-making, 138; weeding, 139; corn, pasturing, and harrowing, 140; watering lands, 141; draining, 143; fencing, 144; trees, management of, 145; fruits of the, 146; grasses, cereal, 148; legumes, 149; sesamum, 150; plants, herbage, 151; crops used in the arts, 152; crops, ligneous, 153; fruit trees, 154; animals, 156; maxims, 157.
- Romney marsh, 4559.
- Ronalds's select list of orchard apples, 4098.
- Ronconi*, Ignazio, his work on agriculture, page 1221. A. D. 1804.
- Root, anomalies of the, 1590.
- Root-breaker, 2557.

- Root of a plant, 1307.
 Roots, edible, of the old world, 1785.
 Root-house, the, 2862.
 Roots of trees, use of, 4065.
 Rope-twisting machine, 2562.
 Roscommon, statistics of, 7882.
 Roseneath, in Dunbartonshire, 7843.
 Rosin, 1454.
Rössig, Karl Glo., his works on agriculture, page 1219. A. D. 1781.
 Ross-shire, statistics of, 7884.
 Rotation of crops, necessity of a judicious, 4912. 4927.
 Rotations suited to different soils, examples of, 4933.
 Rotting in trees, to prevent, 4030.
Roughly, Thomas, his work on agriculture, page 1223. A. D. 1823.
 Roxburghshire, statistics of, 7836.
Rozier, François, his works on agriculture, page 1216. A. D. 1770.
 Rubbing-post for pigsties, 2838.
 Rules for the arrangement of farm labour, 4913.
 Rush, the esparto, in Spain, 722.
 Russia, portion of, fit for aration, 664; climates of, 665; surface of, 669; soil of, 670; landed property in, 671; the farmeries of, 672; agricultural products of, 673; farming crops of the more southern regions of, 674; the culture of herbage plants in, 675; plants grown for commercial uses in, 676; fruits generally grown in, 678; live stock of the farmer in, 679; forests of, 680; implements and operations of husbandry in, 683; field operations of, 684; improvement of agriculture in, 685.
 Rutlandshire, statistics of, 7802.
 Rye, 5069; varieties of, 5070; soil for, 5071; climate for, 5072; when sown, 5073; after-culture, harvesting, and threshing of, 5074; use of, 5075; as a green crop, 5076; spur, or ergot of, 5079; insects injurious to, 7662.
Rye, George, his work on agriculture, page 1208. A. D. 1730.
 Rye, insects injurious to, 7662.
 Rye-grass, the biennial, 5654; the perennial, 5655; the new varieties of, 5656.
- S.
- Sack-barrow, the, 2541.
 Saddle-grafting, a peculiar mode of, practised in Worcestershire, 7792.
 Saffron, the, or autumn crocus, 6169, uses of, 6173.
 Saffron, extract of, 1412.
 Sagapenum, 1479.
 Saintfoin, 5595; varieties of, 5596; soil for, 5597; sowing, 5599; after-culture and management of, 5603; taking and using the crop of, 5606; duration of, 5609; produce of, 5610; nutritive products of, 5611; saving the seed of, 5612; threshing out the seeds of, 5614; produce in seed of, 5616; diseases of, 5617.
 Salep plant, culture of the, 6184.
 Salesman, agricultural, 7748.
 Saline solutions, as a manure, 2308.
Salisbury, W., his work on agriculture, page 1213. A. D. 1822.
Salmon's attempt at a reaping-machine, 2735.
 Salmon, 7584; enemies of the young, 3889; fishery of, 3885; in rivers, 7850; spawning of, 7850; various modes of taking, 3895; weirs for, Marshal's opinion of, 3900.
 Salmon trout, 7850.
 Salop, 1401.
 Salt, as a manure, 2306; good for most animals, 2074; production of, 3872.
 Salts, as part of the food of plants, 1530.
Salvini, Gio., his work on agriculture, page 1221. A. D. 1777.
 Sandarach, 1457.
 Sandwich Isles, the, 1059.
Sang's opinion on pruning, 3989.
 Sap, 1495; ascent of the 1539—1544; causes of the, 1545—1550; elaboration of the, 1551; perspiration of, 1555; of plants, 1475.
Sarcey-de-Sutieres, his works on agriculture, page 1215. A. D. 1765.
Sartorelli, G. B., his work on agriculture, page 1222. A. D. 1826.
 Sauerkraut, 5507.
Saussure's experiment respecting vegetable extract as the food of plants, 1529.
 Savory, culture of, 6180.
 Savoy, agriculture of, 354; land in, 355; lands of the monasteries in, 356; peasantry of, 357; four modes of occupying land in, 359; land near towns, 560; farming land in, 361; occupying land in, by grangers and by tacheurs, 362, 363; leases granted to the farmers and grangers in, 364; pasturage in, 365; public dairies in, 366; sheep in, 367; vineyards in, 368; walnut trees in, 369; walnut harvest in, 370; tobacco in, 373; artificial grasses in, 374; grass lands and water meadows of, 375; agricultural improvements in, 376; salt-works of Montiers in, 377.
 Saw, the, 2490.
 Sawing, 3150.
 Saxony, state of agriculture in, 607; culture of the vine and silkworm in, 608; the wool of, 609; general rotation of crops in, 610; cows of, 611; Jacob's opinion of the agriculture of, 613.
 Scales of animals, 1869.
 Scammony, 1475.
 Scarcement in hedgemaking, arguments for and against a, 3009.
 Scarifier, Henry's improved, 2673.
 Scarifier or hash, the Sithney, 2716.
Scheffold, L., his work on agriculture, page 1220. A. D. 1809.
Schönlenter, M., his work on agriculture, page 1220. A. D. 1810.
Schuster, J., and M. Haberle, their work on agriculture, page 1220. A. D. 1825.
Schwartz, N., his work on agriculture, page 1220. A. D. 1825.
Scirpus tuberosus, the, of China, 986.
 Scorer, the, 2491.
 Scotland, agriculture of, after the Norman Conquest, 208; during the thirteenth, fourteenth and fifteenth centuries, 213; in the fifteenth and sixteenth centuries, 215; agriculture of, in the sixteenth century, 226. 241; in the seventeenth century, 242; agriculture in, during the Revolution, 770; first improvement in the roads of, 771; benefit to the agriculture of, 772; general remarks on, 7832.
 Scraper, the, 2464.
 Scraping, 3133.
 Scraping roads, 3748.
 Scythe, the Hainault, 509. 2479; the great Brabant, 510; the cradle, 2480; for reaping grain crops, 3179; used in irrigation, 4401.
 Scal, the, 3893.
 Seas, inconsiderable, temperature of, 2351.
 Season for cutting trees whose barks are not made use of, 4044; for sawing, cutting, or clipping living trees, 2156.
 Season, a wet, 2435.
 Seasoning of timber, 4063; by steeping, 4064.
 Sea-trout, 7850.
 Sea wall embankment, 4352.
 Sea-water, as a means of irrigation, 4445.
 Sea-weed, use of, 6187.
 Sea-weeds, as a manure, 2237.
 Sea-wrack grass, 6195.
 Secretions, unctuous, of the skin, 1875; viscous, 1876.
 Seed, dispersion of, 1642.
 Seed-basket, 2526.
 Seed-corn, choice of, 4855.
 Seed farmers, 7729.
 Seed harrow for wet weather, Gray's, 2704.
 Seed sown, returns of, mentioned by the ancients, 167.
 Seeds of trees, use of, 4041.
 Selkirkshire, statistics of, 7837.
Sénac, M., and the Baron de Ferrussac, their work on agriculture, page 1219. A. D. 1826.
 Senna, extract of, 1410.
 Sensation of plants, 1668.
 Serpent's motion, the, 1903. 1906.
 Serradilla, the, 5639.
Serres, Olivier de, his work on agriculture, page 1214. A. D. 1600.
 Servants, choice of, for the farmer, 4866; the mode of hiring at public statutes, 4869; management of, 4900.
 Servants, female, required in a farmery, 4878.
Servières, B. de, his work on agriculture, page 1216. A. D. 1786.
Sésamum orientale, 978. 6097.
 Setters, 7400.
 Settlers in the United States, practice of, 1165.
 Sexes of plants, 1622.
 Shade and shelter for certain plants, necessity of, 1827.

- Shafts, double, advantage of, on roads, 3742.
 Shakes in trees, to remedy, 4031.
 Shapes which indicate a propensity to fatten soonest, 2031.
 Sheath, the, or land-guard of loose stones, 4366.
 Sheaves of corn, an improved method of setting up, 3177; methods of drying, 704.
 Sheaving of corn, 3175.
 Sheds, portable, for pasture lands, 5838.
 Sheep, the, 7112; the common, in a wild state, 7113; value of, to the British farmer, 7114.
 Sheep, varieties of, 7115; the long-woolled British, 7117; the short-woolled, 7118; the hornless breeds, 7119; sheep best suited to arable land, 7120; the long-woolled large breeds, 7121, the shorter-woolled varieties, 7126; sheep that range over the mountainous districts of Britain, 7133, the Spanish or Merino breed, 7138.
 Sheep, criteria of properties in, of an excellent ram, 7142; of a sound healthy sheep, 7143; of age, 7144; names of the different ages and conditions of sheep, 7145.
 Sheep, breeding, 7146; season of putting the rams to the ewes, 7153; period of gestation, 7154; keep of sheep after lambing, 7159; castrating lambs, 7160; weaning of lambs, 7161.
 Sheep, rearing and management of, 7162; on rich grass and arable lands, 7166; treatment of the lambs, 7168; selection of the lamb stock, 7170; selection of the grown stock, 7172; shearing, 7173; washing, 7177; marking, 7185; shortening the tails, 7186; rearing and management on hilly and mountainous districts, 7190; store farming, 7192.
 Sheep, folding, 7208.
 Sheep, fattening, 7219; fattening lambs, 7224.
 Sheep, the Merino breed, 7240; introduction of, 7231; Dr. Parry's experiments with, 7232; shearing of, 7235; produce of the wool of, 7236; Lord Somerville's experiments with, 7237.
 Sheep, anatomy and physiology of, 7239; skeleton of, 7241; the visceral and soft parts, 7242; wool of, 7243.
 Sheep, diseases of, 7244; of lambs, 7273.
 Sheep, the Berkshire polled, 7790; of Berwickshire, 7835; in Buckinghamshire, 7783; of the Cape of Good Hope, 1127; of the farm of Coldingen, near Hanover, 600; of Dorsetshire, management of, 7819; of the Hebrides, 7859; of Hindustan, 913; the Hungarian, 632; improvement of, on the farm at Moegelin, 585; in Leicestershire, 7798; of Perthshire, 7849; of Spain, 735; management of, 737—742; when first fed on the ground with turnips, 237.
 Sheep-shearing in Spain, 741.
 Shell-fish fishery, 3583.
 Shell sand, as a manure, 2288.
 Shell slug, the, 7706.
 Shells of animals, 1870.
 Sheltering farm-lands, 4584.
 Sheltering and shading lands, 2215, 2216.
 Shepherd, the, 4876.
 Shetland Isles, statistics of the, 7861.
 Shirreff, John, his work on agriculture, page 1213. A. D. 1814.
 Shocking of corn, 3175.
 Shoeing of horses in Flanders, 520.
 Shoots, annual, 1569.
 Shorelands, improvement of, 4567.
 Shovel, the, 2446.
 Shovelling, 3124.
 Shropshire, statistics of, 7795.
 Siam, the kingdom of, 949; agriculture of the, 950; soil of the, 951.
 Sickle, for reaping grain crops, 3179.
 Sickler, F. Ch. L., his work on agriculture, page 1220. A. D. 1805.
Sida tiliæfolia, use of, in China, 982.
 Siebe's rotatory pump, 4501.
 Sierra Leone, description of, 1105.
Sicue, works on agriculture, p. 1216. A. D. 1769.
 Sieves, 2523.
 Sifting earth or gravel, 3135.
 Silicia in animals, 1932; in plants, 1504.
 Silk, culture of, in Hungary, 629.
 Silkworm, the, 7595; breeding of, 7596; in the south of France, 415.
Simonde, J. C. L., his work on agriculture, page 1221. A. D. 1801.
Simpson, Pinder, his works on agriculture, page 1213. A. D. 1814, 1815.
Sinclair, George, F.L.S., F.H.S., &c. his work on agriculture, page 1213. A. D. 1824.
Sinclair, Right Hon. Sir John, Bart., LL.D., &c. his works on agriculture, page 1210. A. D. 1790.
Sinety, André Louis Esprit, his work on agriculture, page 1218. A. D. 1803.
 Situation for a landed proprietor's mansion, the most desirable, 3506.
 Skeibo farmery, 4163.
 Skin and leather, refuse of the manufactures of, as a manure, 2251.
 Skin, secretions of the, 1874.
 Skins of animals, use of the, 2017.
 Skirting lands, 3210.
 Skreen plantations, 4585.
 Sleep, the positions assumed by animals during, 1910.
 Sleeping-rooms for single men, 2868.
 Sligo, statistics of, 7886.
 Slit method of planting, 3947.
 Slit-planting, an expeditious mode of, 3953.
 Slugs, 7705.
 Sluice, a, 4406.
Small, James, his work on agriculture, page 1210. A. D. 1784.
Smith, John, his work on agriculture, page 1207. A. D. 1670.
Smith, Rev. John, D. D., his work on agriculture, page 1211. A. D. 1798.
Smith, William, his works on agriculture, page 1212. A. D. 1806.
Smith's attempt at a reaping machine, 2736; his opinion on irrigation, 4387.
Smithy, on a large farm, 2869.
 Smoking tobacco, antiquity of, 6124.
 Smut, the, in corn, 1693. 5064.
 Smut machine, the, 2796.
 Snail, the edible, 7618.
 Snails, 7707.
 Snow, 2376; of great use to the vegetable kingdom, 2377; heat produced from, 2324.
 Societies, agricultural, 7911; lately formed in Britain, 800.
 Society of Arts, the, 7913.
 Society of Improvers in the Knowledge of Agriculture, in Scotland, institution of the, 793.
 Society, state of, as influencing agriculture, 1270.
 Soda in animals, 1928.
Soderini, Giovanvettorio, his work on agriculture, page 1221. A. D. 1622.
 Soil among trees, culture of, 3980.
 Soil, as influencing agriculture, 1263.
 Soils, exhaustion of, 1534; fertility of, restored, 1535; how distinguished from masses of earth, 2114; classification of, 2117; naming the genera of, 2118; naming the species of, 2119; table of, 2120; to discover the value of, 2121; indicated by the plants growing on them, 2122; the qualities of, discovered by chemical analysis, 2133; the qualities of, discovered mechanically and empirically, 2137; the absorbent powers of, 2145; popular distinctions of, 2157; chemical agency of, 2160; improvement of, 2162; pulverisation of, 2163; consolidation of, 2172; aeration or fallowing of, 2174; alteration of the constituent parts of, 2180; the capacity of, for retaining water, to ascertain, 2144; incineration of, 2191; burning of, 2192; water with respect to, 2199.
 Soils, mixed or secondary, 1743; aquatic, for plants, 1744; earthy, of plants, 1747; vegetable, of plants, 1755.
 Soils, the most proper, for irrigation, 4386; *Smith's* opinion respecting, 4387; peaty, 2112; spurious peaty, 2113; power of vegetables to exhaust, 2219; in respect to farming lands, 4743; retentive, mode of draining, 4267; use of the, to vegetables, 2145. 2148; the constituent parts of, which give tenacity, 2149; power of, to absorb water by capillary attraction, 2152; power of, to absorb water from air, 2153.
 Solar rays, influence of, on vegetation, 2326.
 Solids, animal, 1957; the soft, 1961; the hard, 1962.
 Solomon Isles, the, 1052.
 Somersetshire, statistics of, 7820.
Somerville, Right Hon. John, Lord, his works on agriculture, page 1211. A. D. 1799.
Somerville, Robert, his work on agriculture, page 1212. A. D. 1805.
 Soot, as a manure, 2268.
 Soaper's waste, as a manure, 2310.
 South America, climate, surface, and soil of, 1226.
 Sowing, 3148.
 Sowing of pine seed in Flanders, 529.
 Spade of the bushman, 1139; the Flemish, 2445; used in irrigation, 4395; the trenching, 512.

- Spadoni*, Paolo, his works on agriculture, page 1222. A. D. 1810.
- Spain, agriculture of, in the middle of the 18th century, 714; during the 19th century, 115; climate of, 716; surface of, 717; soil of, 718; landed property of, 719; bad feature in the old government of, 720; agricultural products of, 721; rotations of common crops in, 733; live stock of the agriculturist in, 734; sheep of, 735; implements of agriculture in, 744; operations of agriculture in, 745; forests in, 747; improvement of agriculture in, 748; cause of the decline of agriculture in, 712.
- Spaniels, 7401.
- Speed*, Adam, his works on agriculture, page 1207. A. D. 1659.
- Speculators of Midlothian, 7833.
- Spermaceti, 1948.
- Splitting the roots of trees, 31.
- Sponges, as a manure, 2253.
- Sponge, a good hygrometer, 2420.
- Spottiswoode, the estate of, an example of successful drainage, 4255.
- Spray of trees, uses of the, 4039.
- Springs, artificial, 4503.
- Springs on lands, injury done by, 2201.
- Spring-latch for gates, 3089.
- Spring, temperature of, influence of, on plants, 1727.
- Spur of rye, 5079.
- Spurry, 5632; culture of, in the Netherlands, 482.
- Spurs of animals, 1866.
- Stable, the, 2816.
- Stacey*, Rev. Henry Peter, LL.B., F.L.S., his work on agriculture, page 1211. A. D. 1800.
- Stack-borer, the, 2488.
- Stack-cover, the, 2912.
- Stack-funnel, the, 2911.
- Stack-guard, the, 3288.
- Stack-yard, the, 2906; *Mitchell's*, 2907.
- Stacking, 3276.
- Stacking stage, 3289.
- Stacking wood for fuel, &c., 3207, 3208.
- Staffordshire, statistics of, 7796.
- Stag, the, 7370.
- Staircases to cottages, economical mode of forming, 2895.
- Stake and rice, protecting hedges by, 3017.
- Standing, in animals, 1899.
- Stanley*, Robert A., Esq., his work on agriculture, page 1213. A. D. 1824.
- Starch, 1400; plants producing, 1402; uses of, 1403.
- Steam-engines, employment of, in draining, 4277.
- Steaming house, the, 2863.
- Steaming machine, on a simple and economical plan, 2805.
- Steaming and washing machine, economical, 2804.
- Stedman*, Captain, his residence in Surinam, 1243.
- Steele*, Andrew, his work on agriculture, page 1213. A. D. 1826.
- Steelyard, *Ruthven's* farmer's, 2570.
- Steeping flax, 5905.
- Steindel*, A. H. von, his work on agriculture, page 1220. A. D. 1800.
- Steining wells, 4479.
- Stem of herbaceous plants, structure of the, 1377.
- Stem of plants, anomalies in the, 1597.
- Stephens*, George, his work on agriculture, page 1214. A. D. 1829.
- Stephens's* mode of forming and planting the single hedge and ditch, 2997.
- Steuart*, Sir Henry, his system of removing large trees, 3955; his conclusions respecting the influence of culture on timber trees, 3973.
- Stevens* and *Liébault*, their work on agriculture, page 1207. A. D. 1616.
- Stevenson's* opinion on the direction of roads, 3547; opinion on the drainage of roads, 3607; base of roads, 3627.
- Stevenson*, W., Esq., M. A., his work on agriculture, page 1212. A. D. 1809.
- Steward, under, 7721; demesne, 7722.
- St. Helena, 1144.
- Stickleback fishery, 3881.
- Stile of falling bars, 3109.
- Stiles, 3108.
- Stillingfleet*, Benjamin, his works on agriculture, page 1208. A. D. 1759.
- Stimulants, artificial, to the vital principle of plants, 1666.
- Stipulæ of plants, 1316.
- Stirlingshire, statistics of, 7814.
- Stock farmers, 7735.
- Stocking a farm, 4826.
- Stocking pastures, 5825.
- Stone*, Thomas, his works on agriculture, page 1210. A. D. 1785.
- Stone tracks in roads, advantages of, 3540.
- Stones, breaking, 3121.
- Stone-breaking machine impelled by steam, 2556.
- Stones, *Edgeworth's* mode of breaking, for roads, 3656.
- Stone-hewing machine, 2809.
- Stones on lands, to get rid of, 4518.
- Stones, large, *Low's* machine for raising, 2810.
- Stones, machine for breaking, for roads, 3659.
- Stones, proper size of, for roads, 3662.
- Stop-drag for carriages going down hill, *Rapson's*, 2759.
- Storax, 1485.
- Store farmers, 7736.
- Streams, artificial, 4464.
- Strobile of plants, scales of the, 1356.
- Stubble, as a thatch for ricks, 3187.
- Stubble or dew rake, 2453.
- Stubble-rake, the, 2725.
- Stumming cider-casks, 4132.
- Stumpf*, G., his work on agriculture, page 1220. A. D. 1794.
- Straw of barley, use of, 5118.
- Straw of corn, uses of the, 4990.
- Straw of rye, manufacture of, into plaits, 5077.
- Straw of wheat, uses of, 5051.
- Straw, dry, as a manure, 2238.
- Straw-house, the, 2864.
- Straw-rope making, 3184.
- Straw-rope twister, 2469.
- Straw-yard, the, 2913.
- Strickland*, G., Esq., his work on agriculture, page 1214. A. D. 1829.
- Structures, agricultural, of the Mexicans, 1185.
- Styrax, 1486.
- Subsoil, relatively to the choice of a farm, 4760.
- Succession, natural, of trees, 3918.
- Suckow*, G. Adg., his work on agriculture, page 1219. A. D. 1775.
- Suction, mode of adhesion by, in some animals, 1896.
- Suffocation of plants, 1707.
- Suffolk punch, the, 6242.
- Suffolk, statistics of, 7787.
- Sugar, 1398; utility of, 1399; culture of, among the Moors, 711; in animals, 1946; from the beet root, manufacture of, in the Netherlands, 476.
- Sugar-cane, culture of, in Jamaica, 1212; in Malaga, 729; management of, in Egypt, 1082; the, in Hindustan, 895.
- Sugar plantation, buildings required for a, 1204; live stock of a, 1209.
- Sulphate of iron, as a manure, 2300.
- Sulphate of potassa, as a manure, 2307.
- Sulphur in animals, 1923.
- Sumatra, description of, 1021; live stock of, 1027.
- Summer-fallowing in Scotland, when first practised, 794.
- Summer, temperature of; influence of, on plants, 1728.
- Sunflower, the, as an oil plant, 6100.
- Sutherland, statistics of, 7856.
- Surface, character of, in regard to farming lands, 4769.
- Surface, general, of land estates, to portray, 3351.
- Surfaces, grassy, formation of, 5714.
- Surface-gutters made by cart wheels, 4301.
- Surfaces, primitive, affecting plants, 1741.
- Surgeon, veterinary, 7755.
- Surinam, climate, surface, and soil of, 1242; products of, 1243.
- Surrey, statistics of, 7778.
- Sussex, statistics of, 7779.
- Swan, the mute or tame, 7518; other species, 7519; rearing, 7520; feathers and down, 7521.
- Swayne*, G., A. M., his work on agriculture, page 1210. A. D. 1790.
- Sweat of animals, 1877.
- Sweden, state of agriculture in, 686; climate of, 687; surface of, 688; soil of the valleys of, 690; landed property of, 691; cottages of, 692; the fence in general use, 691; agricultural products of, 695; live stock of the farmer in, 702; implements and operations of agriculture in, 703; forests of, 705; the chase in, 706; improvement of the agriculture of, 708.
- Sweeping, 3134.
- Sweeping roads, 3750.
- Sweepings of houses, as a manure, 2267.
- Swimming, the action of, 1908.
- Swinbourne*, R., his work on agriculture, page 1213. A. D. 1819.

- Swine, abhorrence of, in the western counties of Scotland, 7842.
- Swine, 7274; common hog, 7274; wild boar, 7276.
- Swine, varieties of the common hog — the European, 7283; the Chinese, 7284; the Berkshire breed, 7286; the Hampshire breed, 7287; the Shropshire breed, 7288; the Gloucestershire breed, 7289; the Herefordshire breed, 7290; the Rudgwick breed, 7291; the large spotted Woburn, 7292; the Wiltshire breed, 7293; the Yorkshire breed, 7294; the Northamptonshire breed, 7295; the Leicestershire breed, 7296; the Lincolnshire breed, 7297; the Norfolk breed, 7298; the Suffolk breed, 7299; the swing-tailed breed, 7302; the Highland breed, 7304; the old Irish breed, 7305.
- Swine, breeding and rearing of, 7306.
- Swine, fattening of, 7315; curing or pickling of pork; 7322; curing of bacon, 7324.
- Swine, diseases of, 7329.
- Swine of Perthshire, 7849; of Hindustan, 915; of Hungary, 635; wild, of Paraguay, 1231.
- Switzerland, agriculture in, 326; landed property in, 329; valleys of the Alps of, 330; *éboulemens* of, 331; Mont Grenier, in, 333; avalanches of, 334; glaciers of, 335; cottages of, 336; villages of, 337; the vine in, 338; fruit trees of, 339; woods and forests of, 340; timber, 341; the chamois goats of, 342; pastures and mowing grounds of, 343; cows, goats, and sheep of, 344; cheeses of, 346; Schabzieger cheese of, 347; Gruyère cheese of, 348; ewe-milk, cheese of, 349; agricultural establishment at Hofwyl in, 350.
- System, the circulating, in animals, 1970.
- T.
- Table of cider apples of established reputation, 4089.
- Tacambac, 1459.
- Tail drain, 4414.
- Tallow, 1951; of Croton, 1451.
- Tallow-tree of China, 976.
- Tameness, a proper, desirable in live stock, 2028.
- Tamus* elephantipes, 1137.
- Tannin, description of, 1419; utility of, 1420.
- Tar, 1455.
- Tarello*, Camillo, his works on agriculture, page 1221. A. D. 1772.
- Tares, 5257; varieties of, 5258; soil for, 5262; sowing, 5264; after-culture of, 5270; reaping for sowing, 5271; produce of, 5274; application of, 5276; diseases of, 5279.
- Targioni*, Luigi, his works on agriculture, page 1221. A. D. 1802.
- Tartary, independent, extent of, 878; climate of, 879; surface of, 880; soil of, 881; produce of, 882.
- Tartary, Chinese, agriculture of, 1013.
- Tatham*, William, his works on agriculture, page 1211. A. D. 1798.
- Taxes, and other burdens, 4802.
- Taxonomy, 1301.
- Tea districts of China, 968.
- Tea plant, culture of the, in China, 969; gathering of the leaves of the, 970; curing of the leaves of the, 971; the different sorts of, 972; the more select sorts of, 973; substitutes for the, 974; the oil-bearing, 975.
- Teasel, the, 5935; varieties of, 5936; soils for, 5937; sowing, 5938; after-culture of, 5940; taking the crop of, 5242; produce of, 5945; use of, 5946; to save seed of, 5947; injuries to which it is liable, 5948.
- Telford's* directions for repairing roads, 3774; opinion on wheels proper for roads, 3731; opinion of the width of roads, 3596; side-drains for roads, 3608; road fences, 3619; base of roads, 3627.
- Temperature as affecting the distribution of plants, 1725; variations in the, 2350; as influencing agriculture, 1259; of a country, rules for determining, 1730; effects of, on the distribution of animals, 2004; in the three zones, the most remarkable circumstances respecting, 1731.
- Tenancy, different species of, 4672.
- Tenants, management of, 4665; proper treatment of, 4666.
- Tench, 7575; stocking with, 7576.
- Tendrils of plants, 1315.
- Tenure on which lands are held for farming, 4786.
- Terms, technical, of science, use of, 1293.
- Terra del Fuego, 1246.
- Terra Firma, climate, surface, soil, and productions of, 1227.
- Terrace, cultivation of the Chinese, 1009.
- Terrier, 7398.
- Tessier*, Henri Alexandre, his works on agriculture, page 1217. A. D. 1791.
- Testa of plants, 1341.
- Testudinaria* elephantipes, 1137.
- Tethering cattle on clover crops, 5560.
- Teviotdale. See Roxburghshire, 7836.
- Textures, the fibrous, of animals, 1958; the cellular, of animals, 1959; the pulpy, of animals, 1960.
- Thaer*, Alb., his works on agriculture, page 1220. A. D. 1798.
- Thatch, application of, to stacks, 3186.
- Thatting, 3185.
- Thatting hay and corn stacks in England, 3188; the roofs of buildings, 3189; with reed, 3190.
- Thatting-knife, the, 2487.
- Theress*, Thdr., his work on agriculture, page 1220. A. D. 1808.
- Thermometer, use of the, 2431.
- Thermometers, scales of the different, 2432.
- Thessaly, agricultural circumstances of, 757.
- Thessaly, the plain of, 757.
- Thibet, climate of, 1014; surface of, 1015; agriculture of, 1017; animals of, 1018; architecture of, 1019.
- Thierat*, his work on agriculture, page 1215. A. D. 1763.
- Thiery*, P. J., his work on agriculture, page 1218. A. D. 1822.
- Thinning out plantations, 4009; the proper season for, 4020.
- Thinning plants, 3141.
- Thinnings of trees, use of, 4040.
- Thirst, the cause of, 1965.
- Thistle-drawers, 2467.
- Thistle extirpator, Baker's, 2466.
- Thistle-hoe, the, 2676.
- Thouin*, M. André, his work on agriculture, page 1218. A. D. 1812.
- Thomson*, Rev. John, D.D., his work on agriculture, page 1211. A. D. 1800.
- Thread plants, 5993.
- Threshing by the flail, 3198.
- Threshing floor, 2849; in Gloucestershire, 2850; boarded, 2851; earthen, 2852; of brick, 2853; of wood, 2854.
- Threshing machine, first notice of one, 795; the first, 2775; second attempt at a, 2776; third attempt at a, 2777; Meikle's two-horse, 2789; Meikle's water, &c., 2788. 2791; Weir's portable two-horse power, 2793; Lester's portable, 2794; Forrest's portable, 2795; the hand, 2546; a locomotive steam, 2548; of a peculiar construction, erected by Stirling at Howmuir, 7850; portable, 2792.
- Threshing and preparatory machines, 2773; improvements on, 2779; advantages of, 2782.
- Threshing-mill barn, the, 2855.
- Threshing wheat, 5044.
- Thunder, cause of, 2390; season of, 2393.
- Thunder clouds, 2395.
- Thunderbolts, 2394.
- Thyme, culture of, 6180.
- Tibbs*, Thomas, his work on agriculture, page 1212. A. D. 1808.
- Tighe*, William, Esq., his work on agriculture, page 1211. A. D. 1802.
- Tillage, Chinese, object of, 997.
- Tillet*, du, his work on agriculture, page 1215. A. D. 1755.
- Timber, price of, 4077.
- Timber surveyor and valuer, 7751.
- Timber trees, the most useful, of temperate and warm climates, 1793.
- Timber trees, the usual modes of disposing, 4078.
- Timber, valuation of, 4069.
- Time-book, the, 3382.
- Tipperary, statistics of, 7878.
- Tithes, 4798; in Ireland, 848.
- Tobacco, species of, cultivated, 6123; annual species of, 6130; species and varieties of, 6131; soil for, 6132; climate for, 6133; culture of, 6134; summer management of, 6141; curing process of, 6142; suggestions respecting, 6144; produce of, 6146; saving the seed of, 6147; value of, as an agricultural crop, 6148; diseases and enemies of, 6152; manufacture of, 6154; of the Cape of Good Hope, 1124; in Hindustan, 899.
- Tokay, preparation of, 627.
- Tollard*, Claude, his work on agriculture, page 1218. A. D. 1805.
- Toll-gates, improved, 3276.
- Toll-house at Edgeware, 3726.

- Tomato, in Sicily, 319.
 Tonquin, description of, 955.
 Tool-house, the, 2866.
 Tools for boring, Good's, 2507.
 Tools, essential, of agriculture, 2475.
 Tops of trees, stunted, cause of, 403; withered or decayed, cause of, 4034.
 Torpidity of animals, 2008.
 Tortoise, the common, 7592; the mud, 7593; the land, of Hungary, 637.
 Towers for watching in used by the Mexicans, 486.
 Town, forming the plan of a, 3849.
Tozzetti, his works on agriculture, page 1222. A. D. 1809.
 Tradesman's yard, 2915.
 Tranquillity necessary for domestic animals, 2079.
 Transfer of landed property, 3455.
 Transplanting, 3144.
Trantman, C. P., his work on agriculture, page 1220. A. D. 1809.
 Treatise concerning the manner of fallowing ground, &c. Anon. page 1207. A. D. 1724.
 Treatise on Milk. Anon. page 1213. A. D. 1825.
 Treatise on Husbandry, the first English, 219.
 Trees, the beauty of, 3906; the best mode of cutting, 4046; culture of the soil among, 3980; large, the transplantation of, 3954; mixture of, in plantations, 3958; natural succession of, 3918; the ordinary products of, 4038; placed round ponds, effect of, 4476; suitable for different soils, 3919; for different climates, 3920; treatment of wounds and casualties in, 4028.
 Trefoil, the bird's foot, 5637.
 Trench, 4412.
 Trench drain, 4413.
 Trenching, 3126.
 Trentham estates, the, 7796.
Trimmer, Joshua Kirby, his work on agriculture, page, 1214. A. D. 1829.
 Troon, harbour of, 7841.
 Trout, the, 7583.
 Tripoli, description of, 1093.
Trother, his work on agriculture, page 1216. A. D. 1773.
 Truck, the, 2543.
 Trunk, a, 4407.
 Trunk of a plant, 1308.
 Trussing straw or hay, 3196.
 Tube, flexible, for cattle, 2531.
 Tubers, edible, of China, 984.
 Tubes of plants, 1380; large, 1381; simple, 1382; porous, 1383; spiral, 1384; false spiral, 1385; mixed, 1386; small, 1387.
Tull, Jethro, agricultural improvement introduced by, 777; his works on agriculture, page 1208. A. D. 1731.
Tull's system of husbandry, 778—785.
 Tunis, agriculture of, 1094.
 Tunnels across a road, 3614.
Tupputi, D., his work on agriculture, page 1222. A. D. 1807.
Turbilly, Louis François Henri de Menon, his works on agriculture, page 1215. A. D. 1760.
 Turbot fishery, 3878.
 Turf-draining, the Cheshire mode of, 4298.
 Turf-knife, the, used in irrigation, 4397.
 Turf-spade, the, 2447; used in irrigation, 4394.
 Turkey, the, 7486; in a state of nature, 7487; varieties of, 7488; breeding, 7489; fattening, 7491; feathers, 7492.
 Turkey, Asiatic, 860; plants and animals of, 862.
 Turkey, European, climate and seasons of, 751; the poorest agriculture in, 761.
 Turkish empire, the, 750.
 Turn of water, a, 4422.
Turner, Nicholas, his work on agriculture, page 1210. A. D. 1784.
 Turnip, the Swedish, 5409.
 Turnip chopper, 2572.
 Turnip drill, the improved Northumberland, 2687; French's, 2688; the Northumberland one-row, 2689; Weir's manuring one-row, 2690.
 Turnip farm of 500 acres, anomalous design for a, 4175.
 Turnip-hoeing, 3265.
 Turnip net, the, 7699.
 Turnip roller, the hand, 2579.
 Turnips, 5373; drilling, 5376; in Northumberland, 7809; varieties of, 5377; introduction of, 236; soil for, 5385; climate for, 5386; field culture of, 5387; sowing, 5394; hoeing, 5403; insects injurious to, 7667; consumption of, 5410; application of, 5419; storing, 5420; produce of, 5423; raising the seed of, 5425; diseases and injuries of, 5431.
 Turnips, growing wild, in Loughnadurb, 7853; hoeing of, in Northumberland, 7809; in Surrey, 7778.
 Turnip slicer, 2571.
 Turnip tray, the, 2529.
 Tuscany, Sismondi's picture of the agriculture of, 276; climate of, 277; soil of, 278; irrigation, 279; plains of, enclosed, 280; arable lands of the plains of, 281; rotation of crops in the plain of, 282; cattle in the plains of, 283; farm-houses of the plain of, 284; farmers of the plains of, 285; culture of the hills and declivities of, 286; soil of the hills of, 287; culture of the olive in, 289; culture of the vine on the hills of, 290; the potato in, 291; the hill farmers of, 292; culture of the mountains of, 293; management of sheep in the mountains of, 294; forests on the mountains of, 295; the mountain farmers of, 296.
Tusser, Thomas, his works on agriculture, page 1206. A. D. 1557.
Twamley, J., his work on agriculture, page 1210. A. D. 1784.
 Tweeddale. See Peeblesshire, 7838.
 Twisting crook, 2469.
 Tyrone, statistics of, 7890.

U.

- Underletting of lands in Ireland, a great evil, 847.
 Under steward, 4639.
 United States, climate of the, 1156; seasons of the, 1157; surface of the, 1158; soil of the, 1159; landed property of the, 1160; mode of dividing and selling lands in the, 1161; price of land in the, 1162; agriculture of the, 1163; political circumstances of the, 1167; agricultural products of the, 1168; live stock of the, 1169; civil circumstances of the, unfavourable to emigration, 1172; want of servants in the, 1173; as a country for a British emigrant, 1174.
 Urea, in animals, 1945.
 Urinarium, the, 2905.
 Urine, as a manure, 2254.
 Utensils, the essential agricultural, 2536.
 Utensils, the principal agricultural, 2522.
 Utricles of plants, 1379.

V.

- Valerian, the common, culture of, 6183.
Vallée, Alexandre, his work on agriculture, page 1221. A. D. 1803.
 Valuation of landed property, 3408.
 Valuation of timber, 4069.
 Valuation of work done, to estimate, 3324; of labour and materials, 3325; of materials alone, 3326; of live stock, 3327; of buildings, 3328; orchards, hop grounds, &c., 3329; of young plantations, 3330; of saleable trees, 3331; of fields for rent, 3332; of a farm for rent, 3333; of leases, 3335; of freehold landed property, 3340; of estates, 3342; of mines and minerals, 3346.
Vancouver, Charles, his works on agriculture, page 1212. A. D. 1807.
 Van Dieman's Land, general description of, 1044; surface of, 1045; soil of, 1046; animals and vegetables of, 1047; the agricultural faculties of, 1048; great advantages of, 1049; the system of farming in, 1050; as a country for emigrants, 1036. 1051.
 Vapour, 2355.
Varenne, de Fenille, P. C., his works on agriculture, page 1216. A. D. 1789.
 Varieties of vegetables, to form new, 1832.
Varlo, C., Esq., his work on agriculture, page 1209. A. D. 1772.
Vaughan, Rowland, his work on agriculture, page 1207. A. D. 1610.
 Vegetable culture, the whole art of, 1835.
 Vegetables, as distinguished from animals, 1291; the colouring matter in, 1414; physical distribution of, 1724; increase in the magnitude of, how to be obtained, 1830; to increase the number and magnitude of particular parts of, 1831; to form new varieties of, 1832; to propagate and preserve from degeneracy, 1833; preservation of, for future use, 1834.
 Vegetable kingdom, divisions of the, 1298.
 Vegetable soils, 1755.

- Vegetation, influence of the aspect of, on man, 1775; territorial limits to, 1723.
- Vermin injurious to trees, to destroy, 4037.
- Vermuyden*, Sir C., his work on agriculture, page 1207. A. D. 1642.
- Village, establishment of a, 3848; forming the plan of a, 3849.
- Villeneuve*, Baron Picot de la, his work on agriculture, page 1218. A. D. 1819.
- Vine, culture of, in the 16th century, 230; exudation of sap in the, 1700; field culture of, when first introduced to Britain, 209; at the Cape of Good Hope, 1120; culture of, in Hungary, 627; in Madeira, 1149; in Spain, 728.
- Vinet*, Elie, his work on agriculture, page 1214. A. D. 1697.
- Vineyards of the Jews, 21.
- Virtues of plants, changed by cultivation, 1620.
- Vitality of vegetables, 1656.
- Vitellus of plants, 1345.
- Vitriol, as a manure, 2300.
- Voght*, Baron von, his work on agriculture, page 1220. A. D. 1824.
- W.
- Waggons, 2763; of the Cape of Good Hope, 1132; of Germany, 557; the Gloucestershire, 2767; the Berkshire, 2768; the Norfolk cart and, 2769; Rood's patent, 2770; Gordon's one-horse, 2771.
- Wagner*, J. Ph., his work on agriculture, page 1220. A. D. 1828.
- Wain, the, of Cornwall, 7825.
- Waistell*, Charles, Esq., his work on agriculture, page 1213. A. D. 1826.
- Waistell's* arrangement of farm buildings, 2921; materials and construction of, 2943.
- Waistell's* cottages for labourers, 2881.
- Walker*, W., his work on agriculture, page 1213. A. D. 1813.
- Walker's* opinion of the width of roads, 3596; side drains for roads, 3608; road fences 3618.
- Walking, the action of, in animals, 1900.
- Wall, the earthen, embankment, 4339.
- Wallachia, agriculture of, 759.
- Wallflower, the, 5636.
- Walls, 3056; of dry stone, 3057; of round or land-stones, 3058; of quarried stones, 3059; the Galloway, 3060; of stone and lime, 3061; of stone and clay, 3063; of dry stone, lipped with lime, 3064; of dry stone, lipped and harled, 3065; of dry stone, pinned and harled, 3066; of drystone, 3067; of brick, 3068; frame, 3069; of turf, 3070; of stone and turf, 3071; of mud, 3072; of rammed earth, 3073; of stamped earth, 3074; of brick-built cottages, economical mode of constructing, 2893; heat produced by, 2323.
- Walnut trees, where serviceable, 4102.
- Warping lands, 2207. 4450; theory of, 4451; effect of, 4453; method of executing, 4454; season for, 4456; expense of, 4457.
- Warwickshire, statistics of, 7797.
- Washing machine, economical, 2804.
- Washington*, Gen. George, his works on agriculture, page 1211. A. D. 1800.
- Waste lands, improvement of, 4512.
- Wastes, woody, improvement of, 4528.
- Water, artificial means of procuring, 4463; as the food of plants, 1522; cisterns for, the best, 4511; for common purposes, to obtain, 4504; composition of, 2330; necessary to vegetation, 2331; exists in the atmosphere, 2334; the decomposition of, by plants, 1560; effect of, on roads, 3579; influence of the qualities of, on plants, 1739; mode of cooling during harvest, &c. in Spain, 746; proper for domestic animals, 2077; proximity of, necessary for a good situation, 3512; raising from deep wells, 4499; an ingenious mode of, 4502; stagnant, injurious to all useful plants, 2200; on land, 4430.
- Waterford, statistics of, 7876.
- Watering barrel, 3753.
- Watering lands, advantages of, 4389; by machinery, 4444.
- Watering, the mode of, natural to vegetables, 1738.
- Watering plants, 3147.
- Watering roads, 3752.
- Water meadow, expenses of making a, 4432; construction of, 4437.
- Water-mills, the most eligible kinds of, 3841.
- Water-tabling of hedges, 3014.
- Water-wheel, the Spanish, 744; the Persian, 2205.
- Wax of myrtle, 1452.
- Wax, vegetable, 1446; properties of, 1447.
- Wax-tree, the, 977.
- Waypane, 4416.
- Wealds, improvement of, 4528.
- Wear, a, 4405.
- Weasel, the, 7629.
- Weather, study of the, 2399; natural data for the study of the, 2401; influence of the moon on the, 2402; artificial data for the study of the, 2407; study of, from precedent, 2433.
- Web, mucous, of animals, 1846; muscular, 1848; cellular, 1849.
- Weber*, F. Bd., his work on agriculture, page 1220. A. D. 1803.
- Wedges, 2490.
- Weeding, 3140.
- Weeding-pincers, 2467.
- Weeding-tools, 2465.
- Weeds, mowing of, 3170.
- Weeds, relative, 6198; absolute, 6199; destruction of, 6200; Holdich's classification of, 6205.
- Weidenkeller*, his work on agriculture, page 1220. A. D. 1825.
- Weighing-cage, 2566.
- Weighing-machine for sacks, 2568.
- Weight of objects, to ascertain, 3319.
- Weld, 5978; soil for, 5979; taking the crop, 5981; produce of, 5983; use of, 5984; saving seed of, 5985; disease of, 5986.
- Well-digging, 4478.
- Well-digging combined with boring, example of, 4483.
- Wells, 4477; operation of making, in Persia, 876; Artesian, 7778.
- West Lothian, statistics of, 7845.
- Western*, C. C. Esq., M. P., his work on agriculture, page 1213. A. D. 1824.
- Westmeath, statistics of, 7873.
- Westmoreland, statistics of, 7811.
- Weston*, Sir Richard, his work on agriculture, page 1207. A. D. 1645.
- Wetness of land, origin of the, 4225.
- Wexford, statistics of, 7866.
- Wheat fly, the, 5066.
- Wheat, frosted, 4999; history and uses of, 5001. 5050; soil best adapted for, 5014; manures best calculated for, 5021; climate required for, 5024; sowing, 5025; after-culture of, 5035; harvesting, 5041; produce of, 5047; diseases of, 5063; cultivation of, in Egypt, 1079; insects injurious to, 7661; in Madeira, 1150; uses of the straw of, 5051; summer, culture of, 5067; produce of, 5068.
- Wheelbarrow, the, 2539; the Normandy, 2542; used in irrigation, 4398.
- Wheeling, 3118.
- Wheels of carts, 2746; Jones's improved iron, 2750; effects of the leverage of, on roads, 3574; of the plough, on placing, 2635; the size of, most proper for roads, 3730.
- Wheel-tracks of stone, Stevenson's, 3702.
- Whin, the, 5629; culture of, 5630.
- Whim, the, in Peeblesshire, improvement of, 7838.
- Whipping out grain, 3202.
- Wicket-gate, the, 3104.
- Wicklow, statistics of, 7865.
- Wiegand*, J., his work on agriculture, page 1219. A. D. 1762.
- Wight*, Andrew, his work on agriculture, page 1209. A. D. 1778.
- Wigtonshire, statistics of, 7840.
- Wildmoor estate of Lord Stafford, 7795.
- Williams*, T. W., his work on agriculture, page 1213. A. D. 1819.
- Williamson*, Capt. Thomas, his work on agriculture, page 1212. A. D. 1810.
- Wiltshire, statistics of, 7816.
- Wind, 2380; prevailing near Glasgow, 2381; prevailing in Ireland, 2383; causes of, 2384; effect of, on roads, 3580.
- Winnowing machine, the, 2545.
- Winstrup*, M., his work on agriculture, 7906.
- Winter*, George, his work on agriculture, page 1210. A. D. 1787.
- Wireworm, the, 7684.
- Withers*, William, junior, Esq., his work on agriculture, page 1213. A. D. 1826.
- Wittmann* and *Denglaez*, their work on agriculture, page 1220. A. D. 1826.
- Woad, 5963; variety of, 5964; soil for, 5965; sowing, 5968; after-culture of, 5970; gathering the crops of, 5971; produce of, 5973; use of, 5975; saving seed of, 5976; diseases of, 5977; culture of, in Flanders, 490.
- Woburn grasses, experiments on the, 5721.

Wood-ashes, as a manure, 2243. 2305.
 Wood-farmers, 7739.
 Woodlands, 3908.
 Woodman, 7715.
 Woods of the Mexicans, 1187.
 Woody fibre, the, 1492.
 Wool of animals, 1852, 1853.
 Wool, exportation of, from Britain, 764.
 Wool of Saxony, 609.
 Wool-shears, 2485.
 Worcestershire, statistics of, 7792.
 Work, quantity of which ought to be performed in a given time, to estimate, 3321.
 Workmen, advantage of orderly conduct in, 3369.
 Worlidge, John, his work on agriculture, page 1207. A. D. 1669.
 Worlidge's Systèma Agriculturæ, 254.
 Worm-like animals injurious to agriculture, 7704 ; of the slug kind, 7705 ; the shell slug, 7706 ; snails, 7707.
 Wormwood, culture of, 6180.
 Wright, Sir James, Bart., his work on agriculture, page 1211. A. D. 1796.
 Wright, Rev. Thomas, his works on agriculture, page 1210. A. D. 1789.
 Wurttembergischer Correspondenz des Landwirthschaft Vereins. Anon. page 1220. A. D. 1825.

Y.

Yams used instead of bread, 7850.
 Yarrow, the, 5642.
 Yellows, vegetable, for dyeing, 1417.
 Yeoman, condition of one about the reign of Elizabeth, 223.
 Yeomen farmers, 7745.
 Yoking of draught animals, 3236.
 Yorkshire, statistics of, 7804.
 Young, Arthur, F.R.S., his works on agriculture, page 1208. A. D. 1767.
 Young, David, his work on agriculture, page 1210. A. D. 1786.
 Yvast, A. Victor, his works on agriculture, page 1218. A. D. 1819.

Z.

Zehmens, Cp. H. Adf. von, his work on agriculture, page 1220. A. D. 1796.
 Zeigerus, Antoine, his work on agriculture, page 1219. A. D. 1735.
 Zizania aquatica, 5186.
 Zoology, the technical terms in, 1839.

SUPPLEMENT.

2789 *a* and 7790 *a*. *Threshing machines*. One of the most complete in England has been erected at the Duke of Gloucester's farmery at Bagshot Park; for the following description and drawings of which we are indebted to Mr. Anderson, an experienced agricultural engineer. This machine threshes the corn, hummels barley, winnows, sifts, and cleans corn, grinds it into flour, cuts the straw into chaff, and grinds bones for manure; and any one of these operations can be performed without the other. The different parts of this apparatus are chiefly taken from machines already in existence, but some also are original. It may be mentioned as a singular and melancholy sign of the times, that the parties who have the chief merit are afraid of giving their names to the public. The agriculturists of a future and, we trust, no distant day will hardly believe it possible that the destruction of threshing machines should have been popular in England in 1830. It is worthy of notice as an argument in favour of the diffusion of knowledge among the labouring classes, that, so far from threshing machines being destroyed in Scotland, they are so much in repute among the labourers of that country, that a farmer who is without one is obliged to pay higher wages to his servants. This fact is well authenticated by a correspondent in the *Examiner* newspaper of February 13. 1831. See the examination of Joseph Forster in No. 1. of *The Working Man's Companion*, and also in *Mech. Mag.* vol. xiv. p. 323.

The mechanical part of the machinery was executed and erected chiefly by Mr. George Miller, now residing near Bagshot. *Fig.* 1139. is partly a section, and partly a side view; *fig.* 1140. is partly a cross section, and partly an end view; and *fig.* 1141. is partly a vertical section, and partly a vertical profile. The same letters are applied to the same parts in all the figures.

Description of the machinery. (*figs.* 1139. 1140. 1141.) *a* is an overshot water wheel 15 feet diameter, which makes from six to eight revolutions per minute according to the supply of water; on the arms of the water wheel is fixed a bevel wheel *b* of 128 cogs (seven feet four inches diameter), working into the pinion *c* of 26 cogs (twenty inches diameter), on the upright shaft *d*: these wheels are below the ground floor, and entirely hid from the view.

On the shaft *d* are two driving wheels *g* and *f*: *g* is a spur wheel of 119 cogs (six feet two inches diameter), driving the pinion *e* of 22 cogs (14 inches diameter) on the shaft *h*, which leads to the floor above, and turns the upper millstone; *f* is a mitre wheel of 40 cogs (two feet diameter), working into two wheels *i* and *k* of the same dimensions.

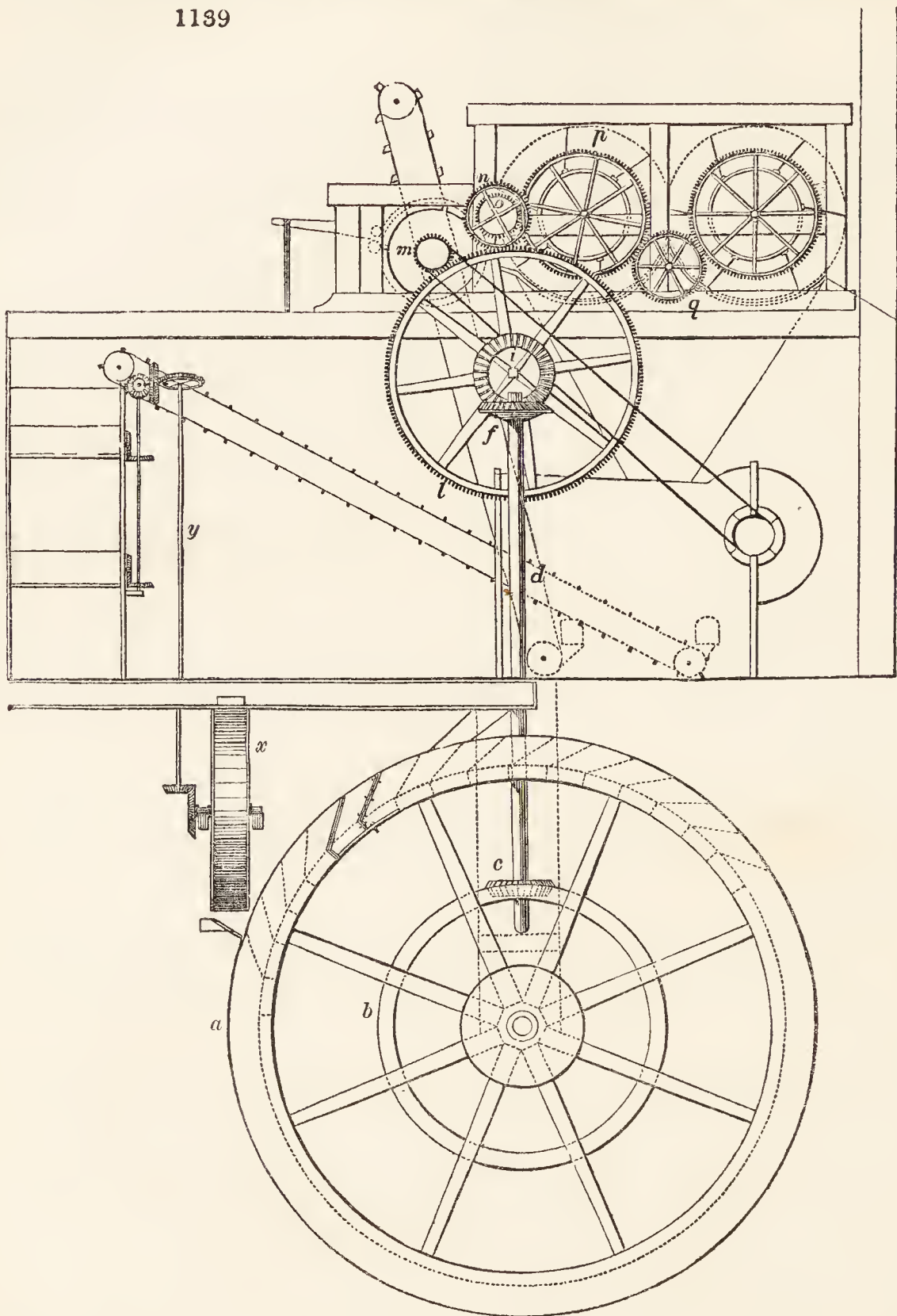
On the same shaft as the mitre wheel *i* is a spur wheel *l* of 200 cogs (six feet eight inches diameter) working into the threshing machine drum pinion *m* of 20 cogs (eleven inches diameter); the spur wheel *l* also drives a wheel *n* of 39 cogs (22 inches diameter), on the same axis of which is a small wheel *o* of 26 cogs (ten inches diameter), working into the wheel *p* of 121 cogs (three feet four inches diameter), on the axis of the first rake or shaker: the wheel *p* gives motion to the intermediate wheel *q* of 72 cogs (two feet diameter), which works into the second shaker wheel of the same dimensions as the first shaker wheel *p*.

On the spindle on which the wheel *n* is mounted is a small shifting pinion *r* of 17 cogs (seven inches diameter), working into the faced wheel *s*, on which are two rows of cogs, one of 20 and the other of 30 cogs each. On the same axis as the faced wheel *s* is a bevel wheel *t* of 20 cogs (eight inches diameter), working into the wheels *u* and *v* of 40 cogs (sixteen inches diameter), on the lower feeding roller spindle; these two wheels are not fixed on the spindle, but revolve freely on turned parts of the shaft, and give motion to it by means of the clutch and handle *w*. When the machine is at work the clutch is in the wheel *v*, giving to the feeding rollers the required motion; should it be necessary to stop the rollers, the handle *w* is moved from the feeding board, and the clutch disengaged from the wheel *v*. Should the handle be moved farther from the feeding board, the clutch is thrown into the wheel *u*, and the rollers turn the reverse way.

The *winnowing machine* under the shakers is driven by a sheave on the drum axis, and a rope leading to a sheave on the fanner spindle; to dress the grain thoroughly, it is conveyed from this machine, and passes through two winnowing machines, one placed above the other: this is effected by means of a canvass cloth on which are strips of wood half an inch in thickness; the cloth revolves on two rollers, and is set in motion by a rope leading from a sheave on the shaft *i* to a sheave on the upper roller spindle.

As it is absolutely necessary to have a steady and uniform motion to produce the best possible sample from a winnowing machine, and as the velocity of the threshing machine is subject to vary, from irregular feeding and other causes, the winnowing or dressing machines are set in motion by a small water-wheel *x*, five feet diameter, on the axis of

1139

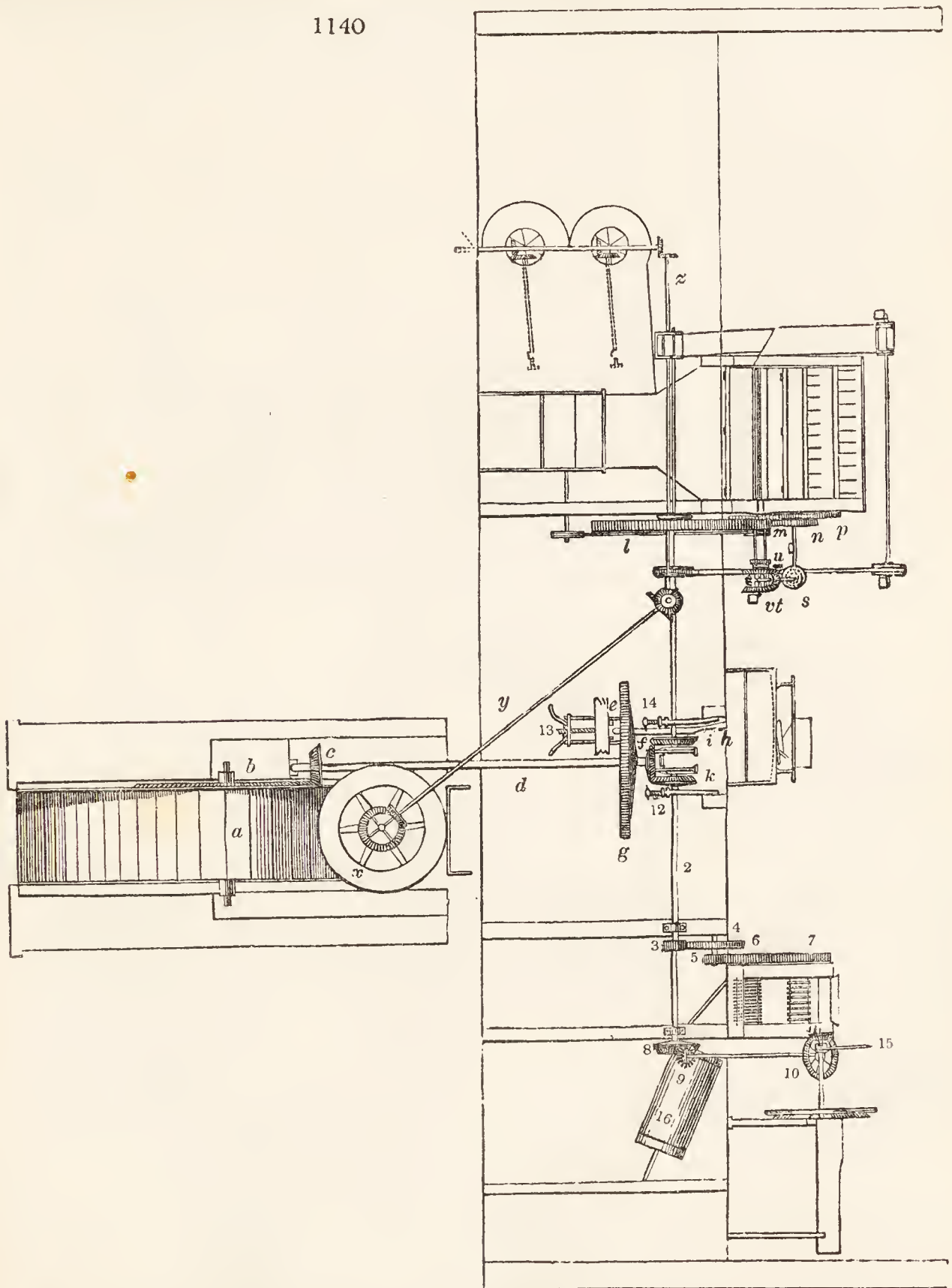


which is a bevel wheel twenty inches in diameter, working into a pinion on an inclined shaft *y*. On the upper end of the shaft *y* is a bevel wheel working into a pinion, on the axis of which is another bevel wheel giving motion to the shaft *z*, which turns the fanners by means of small mitre wheels.

The bone-mill and chaff-cutting machine are driven by the mitre wheels *f* and *k*. On the shaft 2 is a shifting pinion 3 of sixteen cogs (ten inches diameter), working into the wheel 4 of 49 cogs (two feet four inches diameter), on the axis of which is a pinion 5 of 16 cogs (ten inches diameter), driving the wheel 6 of 49 cogs (two feet four inches diameter), in the axis of one of the lower crushers: the upper pair of crushers are driven by the wheel 6 working into a wheel 7 in the upper crush or spindle. The crushing rollers are set to or from each other as the nature of the work may require. When the bones are large, the upper pair of crushers only are used in passing the bones the first time through, an inclined board being placed to prevent them from falling into the lower set; this board is removed at the second time of grinding, and the bones pass

through the two sets and fall into the revolving circular screen 16: any bones that will not pass through the mash of the screen are again put into the mill. The screen is set in motion by the wheel 6 working into a pinion, not shown in the drawing, and by a shaft and universal joint connecting with the axis of the screen.

1140



On the shaft 2 is a bevel wheel 8 of 46 cogs (21 inches diameter), driving the pinion 9 of 19 cogs (nine inches diameter), on an inclined shaft leading to the floor above; on the upper end of this shaft is a bevel wheel 10 of 52 cogs (twenty inches diameter), driving a pinion 11 of 17 cogs (nine inches diameter,) on the spindle of the chaff-cutting machine.

When the threshing machine only is at work, the mitre wheel *k* is thrown out of gear by the lifting screw 12; the pinion on the flour mill spindle is raised above the spur wheel *g* by the screw 13.

When the threshing machine is not at work, the mitre wheel *i* is thrown out of gear by the lifting screw 14.

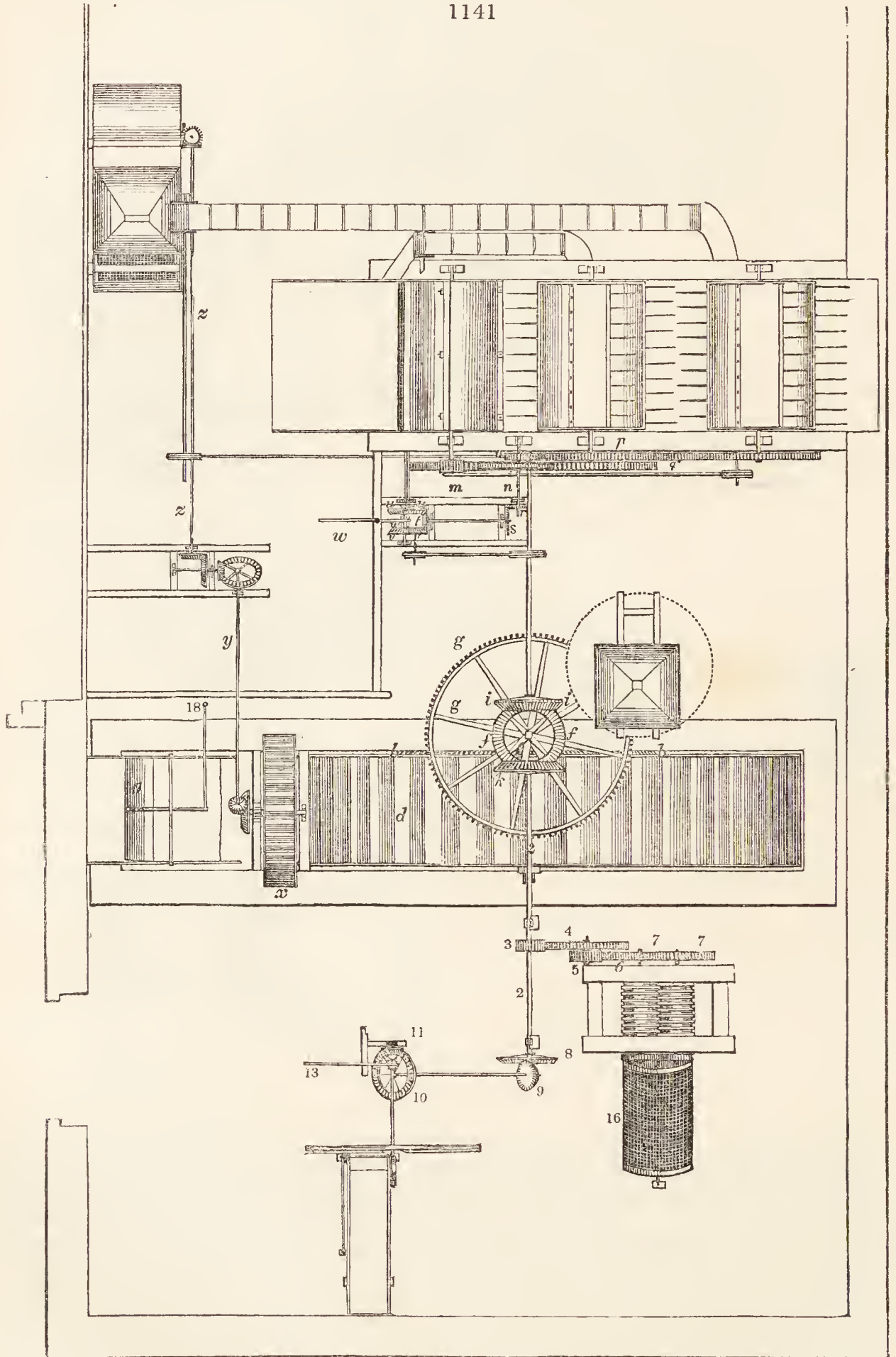
The pinion 3 is kept in its place on the shaft 2 by a key; when the bone-mill is not at work, the pinion is slid along the shaft clear of the wheel 4.

There are three cogs dovetailed into the pinion 9; when the chaff-cutting machine is

not at work these cogs are removed, and the vacant part turned towards the bevel wheel 8; the person attending the chaff-machine can also stop it by the clutch and handle 15.

To stop the water wheel the ring and lever 18 is raised by means of a chain leading over a pulley at the upper part of the building; this raises the sluice board 17; and allows the water to escape clear of the wheel. The water which drives the small wheel *x* is also conveyed by a dash-board under it on to the large water wheel; as this water falls above the centre of the large wheel, the loss of power sustained is not great.

1141



The velocity of the particular parts is found by dividing the product of the number of cogs in the driving wheels by the product of the number of cogs in the driven wheels, and the quotient will be the number of revolutions made by the last moved part, for one of the first moving part. The drum will, therefore, make 49.2 revolutions for one of

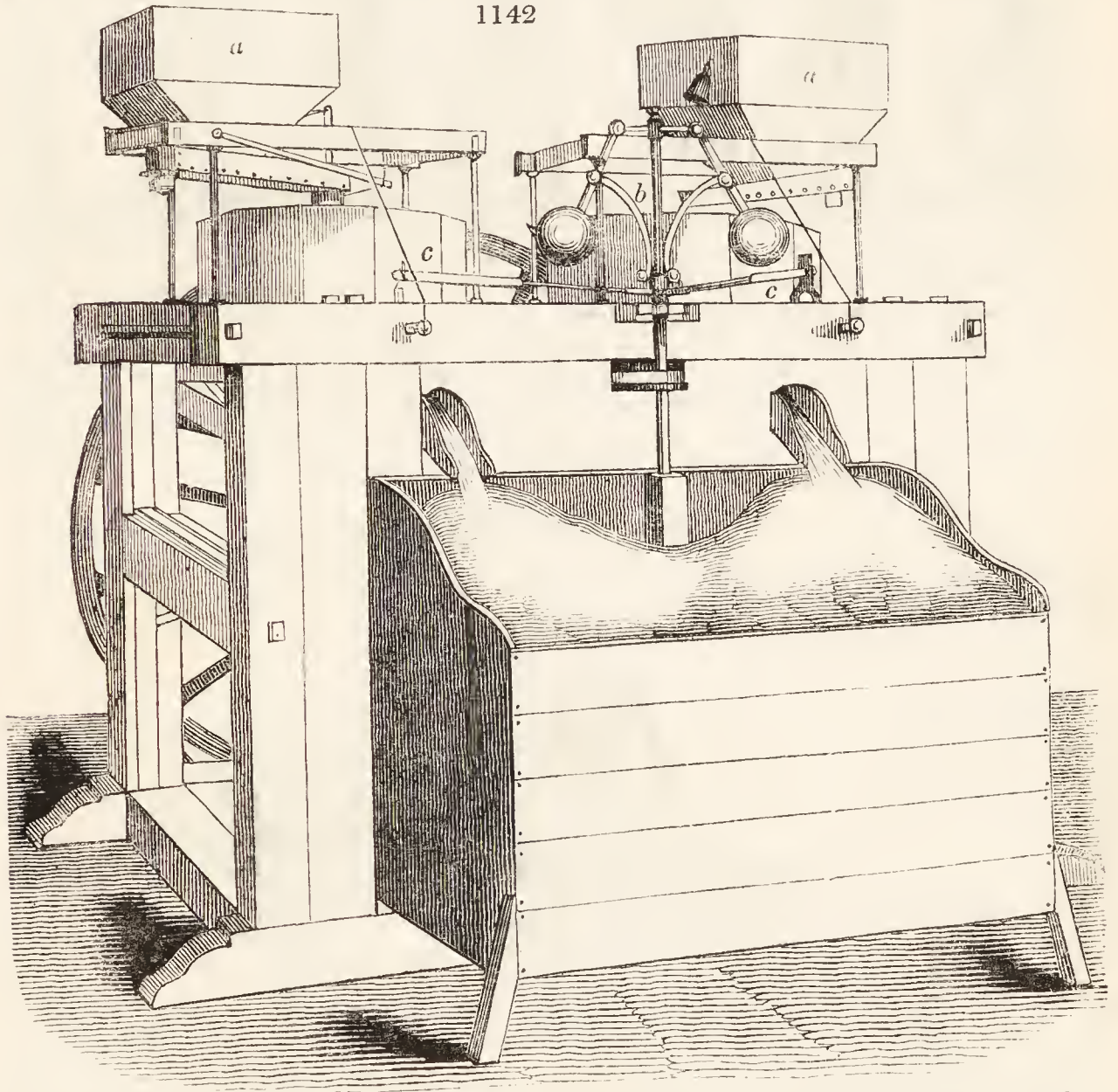
the water wheel; which, multiplied by 7, the medium revolutions of the water wheel per minute, will give 344.4 revolutions of the drum per minute; as the diameter of the drum is three feet, the circumference will be 9.42 feet, which, multiplied by 344.4, will give 3244 feet, the velocity of the beaters or switchers on the drum per minute. By following the same rule

The shakers will be found to make	-	-	-	5.42	} revolutions for one of the water- wheel.
The feeding rollers, quick motion	-	-	-	10.7	
slow motion	-	-	-	7.1	
The upper stone of the flour mill -	-	-	-	26.6	
The chaff-cutting machine -	-	-	-	36.4	
The bone mill	-	-	-	.52	

The operative part of erecting the machine was done by a Mr. George Millar, now residing near Bagshot.

2551 a. A flour mill for a parish workhouse, upon a new and improved principle, (figs. 1142. and 1143.) has lately been erected at the Islington parish workhouse, by

1142

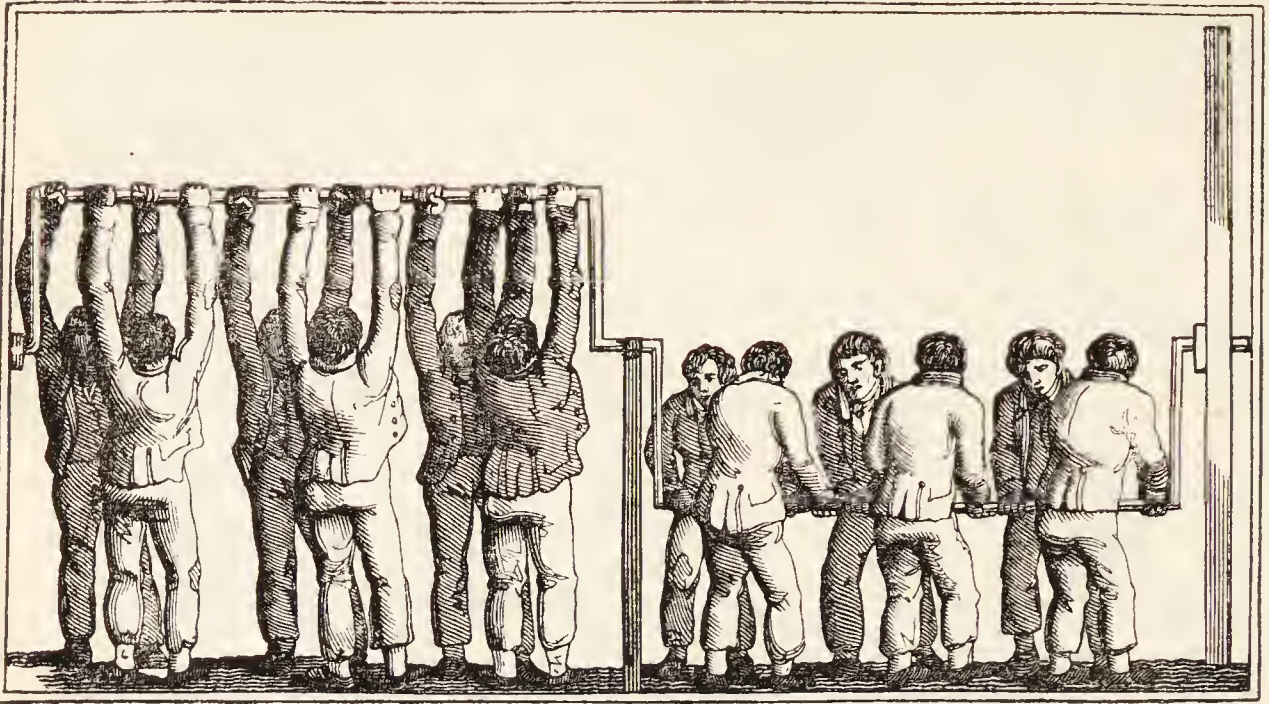


Weir, Oxford street; and as it is admirably calculated for the purpose in view, and may be adopted in many similar cases, we have deemed it well worth a place in this Supplement. It consists of two pairs of stones; one pair of which can be worked separately by six men, or both together by twelve men. The moving power is a crank (fig. 1143.), on the spindle of which is a large fly wheel; and beyond which is a pinion, working into a spur wheel on an upright shaft: this last wheel works into the pinions on the spindles that set the stones in motion. Either of the pinions is of course easily thrown out of gear by a lever.

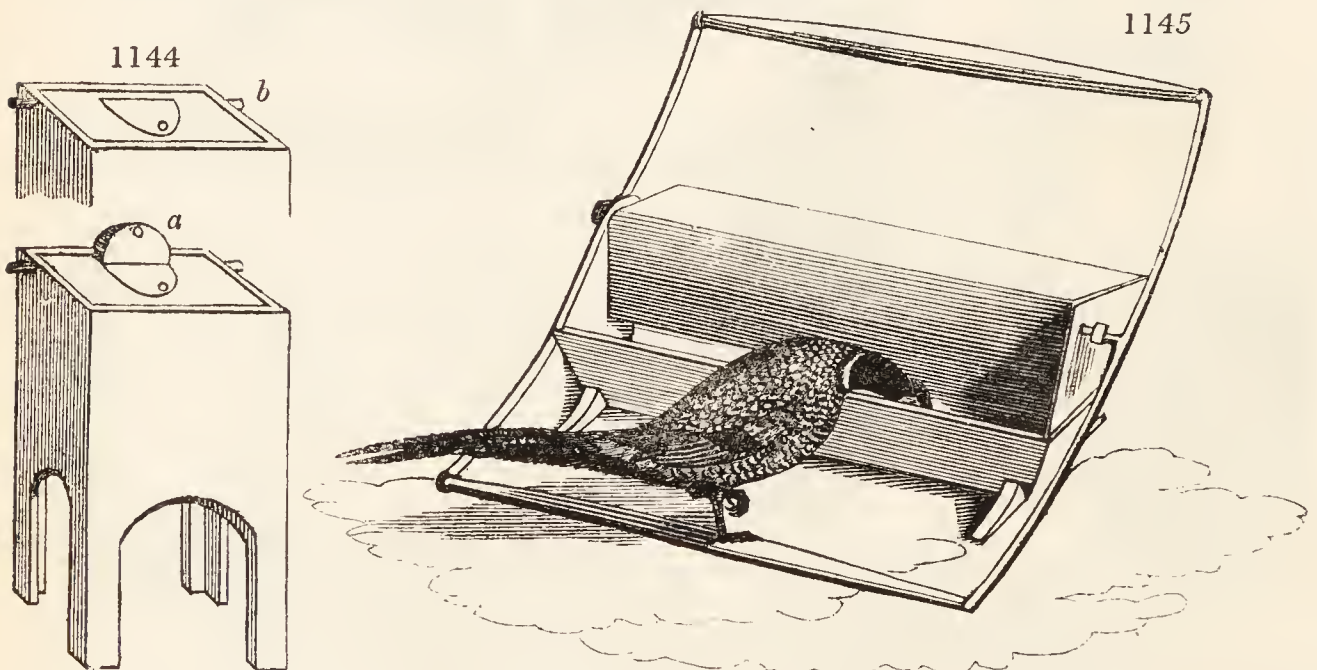
There is a hopper (a, a) to each pair of stones, and one governor (b) which, by means of steel yard bars (c, c) reaching to each pair of stones, regulates their motion. Each pair of stones grinds a bushel and a half of wheat an hour, and the work is performed in as perfect a manner as by any water mill whatever. There is a bolting machine, (see 2552.) worked by a crank and fly wheel, and set in motion by four men. The expense of a flour mill of the above description depends chiefly upon the size of the burr stones; these when large being very expensive. The improvements in this machine are the invention of Mr. Malpas, the foreman at Weir's establishment, a very intelligent

mechanic, and the author of various improvements on the implements and machinery manufactured there, which do him the highest credit.

1143



3088 a. *A fall-down gate-stop* (fig. 1144.) has lately been invented, which deserves adoption wherever double gates are fastened in the middle by a bolt, attached to the lower bar, and entering a hole in a stone or other body fixed in the road. This gate-stopper is formed of cast iron, and is sunk in the ground till its upper surface is level with the road, its lower end being placed on a stone to prevent its sinking too deep. The gate stop has an ear (*a*) which is raised up when the gate is shut, so as to form a stopper and a hole for the bolt; and it is put down (*b*) when the gate is open, so as not to present an obstruction to the feet of horses. Sold by Messrs. Cottam and Hallen.



7548 a. *The pheasant-feeder.* (fig. 1145.) This ingenious invention is manufactured of iron by Messrs. Cottam and Hallen, and seems the best utensil of the kind that we have seen. There is one of tin, lighter and cheaper (see *Gard. Mag.* vol. v. p. 589.), sold by Messrs. Bailey, 272. High Holborn, and by Weir in Oxford street, but it is by no means so durable.

THE END.

LONDON:
Printed by A. SPOTTISWOODE,
New-Street-Square.

FIRST ADDITIONAL
S U P P L E M E N T
TO
LOUDON'S ENCYCLOPÆDIA OF AGRICULTURE;
BEING
NOTICES OF ALL THE PRINCIPAL IMPROVEMENTS
WHICH HAVE TAKEN PLACE IN AGRICULTURE IN BRITAIN,
WITH HISTORICAL NOTICES OF ITS PROGRESS IN OTHER COUNTRIES
SINCE THE PUBLICATION OF THE SECOND EDITION OF THE ENCYCLOPÆDIA OF AGRICULTURE,
IN JANUARY, 1831.

BY J. C. LOUDON, F. L., H., G., AND Z. S., ETC.

THIS Supplement is published in conformity with the intention expressed in the Preface to the second edition of the *Encyclopædia of Agriculture*, p. v. The additions, corrections, or variations, are given in paragraphs, each preceded by two numbers. The first of these numbers is a continuation of the series given in the second edition (which terminates with 7980.), for the sake of reference; and the second number is that of the paragraph, in the second edition of the *Encyclopædia*, to which the correction, addition, or variation refers; to which paragraph, in future impressions, a star will be affixed, in conformity to the plan laid down in p. v., above referred to.

In the compilation of this Supplement we have been guided by the same principles which influenced us in the composition of the original work; namely, that of laying before the reader a great variety of opinions and practices, and leaving him either to generalise on them for himself, or to particularise them, and to adopt such of them as may appear to him most suitable to his individual case. If we had adopted a different mode of proceeding; viz., that of generalising the opinion and practices of others, and giving the result as our own, our work must necessarily have exhibited our own opinion only; whereas, the former mode exhibits all the most valuable opinions and practices, on every subject that it treats of, which have hitherto been published, more particularly in Britain. The young reader is thus induced to think for himself, and to refer his opinions and practices to fundamental principles; while the experienced practitioner may adopt the opinions and practices of those authors in whom he has most faith.

A little reflection will, we think, convince every unprejudiced mind that this method of compilation is calculated to be the most useful in all general works on the practical arts; and, that it is more especially so in the arts of agriculture and gardening will be at once allowed, when it is considered how much the practice of these arts must vary with variations of climate, soil, and other geographical circumstances. How, for example, on any other plan than that which we have adopted, could we have treated on the culture and management of plants and animals, so as to have rendered our Treatise alike suitable for England and Scotland: or how else could we so easily have enabled the reader, who inhabits neither England nor Scotland, to deduce from the practices of those two countries a practice suitable to his own country; say, for example, North America? All knowledge, to be truly useful, must be gained by experience; and the next best thing to gaining experience from personal practice, is to observe and reflect on the practices of others. Our great object throughout, both in the *Encyclopædia* and in this Supplement, has been to instruct—not to lead.

J. C. L.

Bayswater, Sept. 14. 1834.

CONTENTS.

The Numbers refer to the Pages, not to the Paragraphs.

INTRODUCTION, 1233.

History, 1234.

Italy and France, 1234; Holland, 1285; Germany, 1288; Russia and Poland, 1289; Sweden, Persia, India, and Australia, 1291; Egypt, Morocco, and Cape of Good Hope, 1296; North America, 1297.

Agriculture considered as a Science and as an Art, 1298.

Plants and seeds, 1298; mildew, 1299; new varieties of corn, new theory of rotation of crops, 1301; new theory of the operation of manures, noir animalisé, 1302; Dutch ashes, bone dust, application of recent farmyard manure, 1303; humic acid and carbonic acid gas, 1304; implements, instruments, and machines enumerated under this head in the list of engravings, *figs.* 1176 to 1271, in p. iii.; edifices in use in agriculture, labourers' cottages, beau idéal of an English labourer's cottage, 1313; furniture of an English cottage, 1315; external appendages, 1317; the garden, 1318; potato ground, grass land, 1319; plan and elevation of the cottage, 1320; four roadside cottages, 1321; a Gloucestershire agricultural labourer's cottage, 1322; a three-plough farmery on a new and improved construction, 1324; a low-country farm of two ploughs, 1326; a Berwickshire farmery, 1328; ditches and drains, 1329; cutting down old hedges, hurdle-making, paling fences, gates, Russel's gate-stopper, 1330; depth at which seeds ought to be deposited, 1331.

Agriculture as practised in Britain, 1332.

Road-making as practised by Mr. Telford, 1332; Toll-houses and gates, 1337; milestones, 1338; Trees and plantations, 1341; preparing trees for transplanting, 1343; machine for transplanting large trees, sawing-machine for felling timber, 1344; account of the Duke of Athol's larch plantations at Dunkeld, 1345; the fre-

quent-drain system of Mr. Smith of Deanston, 1347; plug or clay draining, embankments, irrigation, Artesian wells, 1350; rending rocks or stones, draining peat bogs, 1351; preparing charcoal from peat-bog, improving moist lands where manure cannot be obtained, the question of corn rents, rotation of crops, 1352; fallows, use of unfermented dung for turnips, 1353; cutting corn crops before they are dead ripe, cutting corn crops with a common scythe, 1354; new varieties of wheat and oats, various experiments on cultivating potatoes, 1355; distillation of spirit from potatoes, Dale's hybrid turnip, fly on turnips, carrot seed, clovers, old pastures compared with new, 1356; sowing the seeds of grasses and herbage plants, 1357; mixtures of grasses for alternate husbandry, 1358; renovating defective meadows, process of drying hops, Reid's improved hopkiln, 1359; buckwheat, Dr. Sully's mode of feeding horses, 1362; feeding horned cattle on raw or cooked food, treatment of cattle in winter, 1363; feeding cattle in hammels and byres, management of milk, 1364; management of cheese, and different cheese-presses, 1365; management of wool in Australia, pigsty at Bagshot Park, 1366; preparation of food for swine, Mallet's improved apparatus for cooking fodder by steam, 1367; treatment of poultry, destroying moles without the use of traps, 1370; catching rats; insects injurious to agriculture, in reply to Mr. Rennie, by Mr. Swainson, 1371.

Statistics of British Agriculture, 1371.

Agriculture of the different countries, application of steam machinery for raising the water from fen and low lands, 1373; Mr. Coke's farmhouses, 1375; Mr. Coke's cottages, Lady Anne Coke's school, description of a machine for making subterraneous drains and bogs, 1376; profits of reclaiming bogs, 1378.

LIST OF ENGRAVINGS.

No.	<i>Landscapes.</i>	Page	No.	<i>Implements, Instruments, and Machines.</i>	Page
1148	View of Wilga, an estate occupied by a British farmer in Poland	- 1289	1176	The underfoot spade	- 1304
1149	View of a Polish village	- 1289	1176	The corn rake	- 1304
1153	Scenery in the neighbourhood of Sydney	1292	1177	Howden's two-edged bill-hook	- 1305
	<i>Trees.</i>		1178	Todd's machine for compressing peat	- 1305
1154	The Stringy Bark, <i>Eucalyptus</i>	- 1293	1179	Slight and Lillie's straw-cutter	- 1306
1155	The Blue Gum, <i>Eucalyptus piperita</i>	- 1293	1180, 1181	Taylor's tub for measuring and weighing corn	- 1306
1156	The Iron Bark, <i>Eucalyptus resinifera</i>	- 1293	1182	Baird's turnip slicer	- 1307
1157	Old Gum, <i>Eucalyptus</i>	- 1293	1183	M'Naughton's machine for sowing carrots	1307
1158	Honeysuckle, <i>Banksia integrifolia</i>	- 1294	1184—1186	Aberdeen mole-trap	- 1308
1159	Apple tree of New Holland, <i>Angóphora lanceolata</i>	- 1294	1187	Smith's subsoil plough	- 1308
1160	Forest Oak, <i>Casuarina torulosa</i>	- 1294	1188—1190	Crosskill's clod crusher	- 1309
1161	The Grass Tree, <i>Xanthorrhæa arbor-escens</i>	- 1294	1191—1193	Threshing machine at Wynn-stay	- 1310—1312
1162	The Broom or Dogwood, <i>Jacksønna scoparia</i>	- 1295	1225—1228	Spade, shovel, and stone-hammers, for roads	- 1339
1163	The Tea tree, <i>Melaleuca linariifolia</i>	- 1295	1229	Instrument for measuring the inclination of roads	- 1341
			1230, 1231	New guard for single trees	- 1341
			1233	Monro's perforator	- 1342

No.	Page	No.	Page
1234	Machine for transporting large trees - 1344	1204—1208	Mackenzie's improved three plough farmery - 1324—1326
1235	Sawing machine for felling timber - 1344	1209—1211	Milne's improved two-plough farmery - 1327
1236	Draining spade - - - 1350	1212, 1213	Blackadder's improved Berwick-shire farmery - 1328, 1329
1238	Scythe for reaping corn - - - 1354	1222	Tollhouse of Mr. Telford - 1337
1248, 1249	Barlas's curd-breaker - 1364, 1365	1239—1247	Read's improved hop-kiln - 1359—1362
1250	Baird's cheese-press - - - 1365	1253—1256	Pigsty at Bagshot Park - 1366, 1367
1251, 1252	Robison's pneumatic cheese-press 1366		
1257—1264	Mallet's apparatus for cooking fodder by steam - - - 1367—1370		
1266—1270	Machine for raising water from fen and low land, driven by steam - 1371—1375		
1271	Machine for making subterranean drains and bogs - - - 1377		
<i>Buildings.</i>			
1146, 1147	Dutch farm-house and farmery, plans and elevations - - - 1286	1152	Stakes used in Sweden for drying newly-cut corn - - - 1291
1150	German cottages, as erected in Poland 1290	1165—1174	Diagrams representing different kinds of mildew - - - 1299—1301
1151	English cottages, as erected in Poland 1290	1232	Diagram for forming a plantation - 1342
1164	Canadian log-house - - - 1297	1237	Section of a narrow-bottomed drain adapted for the plug system - 1350
1194—1196	English labourer's cottage - 1320	1214, 1215	Improved fences, by Mr. Gorrie - 1330
1197, 1198	Four roadside cottages, of the most economical description - - - 1321	1217, 1218	Russel's gate and gate-stopper - 1330
1199, 1200	Mould for forming blocks of earth for pisé cottages - - - 1321, 1322	1219	Germination, &c. of seeds of corn, at different depths - - - 1331
1201—1203	Lawrence's Gloucestershire agricultural labourer's cottage - - 1323	1220	Principles of laying out roads on irregular surfaces - - - 1333
		1221	Inlets to roadside drains - - - 1337
		1223	Turnpike gate at South Mimms - 1337
		1224	Milestones on the Holyhead road - 1338

LIST OF BOOKS REFERRED TO.

The Numbers refer to the Paragraphs, not to the Pages. The Pages mentioned refer to the List of Books in Encyc. of Agr., 2d Edit.

- A Dissertation on Soils and Manures, 8086. Lond. 1816. 8vo.
- An. de Chim. et de Phys., 8059. Annales de Chimie et de Physique. A French periodical, published in Paris, and continued monthly. 8vo.
- Annales des Sciences Naturelles, 8454. Par MM. Audouin, Ad. Brongniart, et Dumas.
- Arch. Mag., 8347. The Architectural Magazine, &c. Conducted by J. C. Loudon, F. L. S. &c. Published monthly. London, 1834. 8vo.
- Architectural Encyclopædia, 8157. See Encyclopædia of Cottage, Farm, and Villa Architecture.
- Beaujour's Sketch of the United States, 8052. Translated from the French, by William Walton, Jun. London, 1814. 8vo.
- Blunt's Italy, 7983. Vestiges of Ancient Manners in Italy. By J. J. Blunt. Lond. 8vo.
- Brooke's Travels in Spain and Morocco, 8049. Sketches in Spain and Morocco, &c. By Sir A. de C. Brooke. Lond. 1831. 2 vols. 8vo.
- Brooke's Travels in Sweden, 8031. A Winter in Lapland and Sweden. By Sir Arthur de Capell Brooke. Lond. 4to.
- Brown's Supp. Prim. Flor. New Holland, 8039. Lond. 1830. 8vo.
- Bulletin de la Société pour l'Instruction Elémentaire, 7988. Published monthly in Paris. 8vo.
- Cadell's Travels, 8024. Cadell's Journey in Carniola and Italy. Lond. 2 vols. 8vo.
- Cape of Good Hope Lit. Gaz., 8047. Published monthly at Cape Town.
- Clairville, 8460. Entomologie Helvétique. 1 vol. Zurich, 1798. 8vo.
- Com. Board Agr., 8028. See Commun. to Board of Agriculture, p. ix.
- Conversations on Vegetable Physiology, 8056. By Mrs. Marcet. Lond. 1830. 2 vols. 8vo.
- Country Times, 8390. See Country Times, p. x.
- Dec., 8064. Prodromus Systematis Naturalis Regni Vegetabilis, Parts 1. and 2. Paris, 1824, 1825. 8vo.
- Dec. Syst., 8058. Regni Vegetabilis Systema Naturale. By Professor Decandolle. Paris, 1818—1821. 2 vols. 8vo.
- Decandolle's Physiologie Végétale, 8056. Physiologie Végétale, ou Exposition des Forces et des Fonctions vitales de Végétaux, &c. By M. Aug. Pr. Decandolle. Paris, 1832. 3 vols. 8vo.
- Dom. Econ. in Lardner's Cyclopædia, 8391. The Cabinet Cyclopædia, &c. Conducted by Dr. Lardner: vol. on Domestic Economy. Lond. 12mo. 1833.
- Dr. Lang's Historical and Statistical Account of New South Wales, 8036. Historical and Statistical Account of New South Wales. By Dr. Lang. Lond. 1834. 2 vols. 12mo.
- Egypt and Mohammed Ali, 8043. By James Augustus St. John. Lond. 1834. 2 vols. royal 8vo.
- Elements of Practical Agriculture, 8104. By Professor Low. Edin. 1834. 8vo.
- Emigration to British America, 8054. By John M'Gregor, Esq. Lond. 1831. 2 vols. 8vo.
- Encyclopædia of Cottage, Farm, and Villa Architecture, 8321. By J. C. Loudon. Lond. 1833. thick 8vo.
- Entom. Jour., 8460. The Entomological Magazine, &c. Published quarterly. Lond. 8vo.
- Farm. Jour., 8599. See Farmer's Journal, p. xi.
- For. Quart. Rev., 7988. Foreign Quarterly Review. Lond., Paris, and Strasburg. In quarterly Nos. 8vo.
- Fraser's Persia, Edin. Cab. Lib., vol. xv. 8034. An Historical and Descriptive Account of Persia from the earliest Ages to the present Time. By James B. Fraser, Esq., forming vol. xv. of the Edinburgh Cabinet Library. Edinb. 1834. 12mo.
- Graham's Mountains near Rome, 7986. Three Months' Residence in the Mountains near Rome. By Maria Graham. Lond. 8vo.
- Granville's Russia, 8326. Travels to St. Petersburg, &c. By Dr. Granville. Lond. 1828. 2 vols. 8vo.
- Grev., 8064. The Scottish Cryptogamic Flora. By Robert Kaye Greville. Edin. 4 vols. 8vo.
- Hayward's Inquiry into the Causes of the Fruitfulness of Plants and Trees, 8194. Inquiry, &c. arranged as a Dialogue. By J. Hayward. Lond. 1834. 12mo.
- Highland Soc. Trans., 8002. See Highland Society's Transactions, p. xii.
- Hist. and Statist. Account, &c., 8039. See Dr. Lang's, &c.
- Hobart Town Courier, 8452. A Newspaper published at Hobart Town, Van Diemen's Land.
- Introduction to Botany, 8156. By Dr. Lindley. Lond. 1832. royal 8vo.

- Jameson's Journ.*, 7985. See *Jameson's Phil. Jour.*
Jameson's Phil. Jour., 8340. The New Philosophical
 Journal, &c. Conducted by Professor Jameson.
 Published quarterly. Edinburgh, 8vo.
Jour. R. Institut., 8056. Journal of Science and
 the Arts. Edited by W. T. Brande, &c. Lond.
 1816. 8vo. Continued annually.
*Journal of a Voyage from Calcutta to Van Diemen's
 Land*, 8046. By Mrs. Prinscapp.
L., 8064. *Systema Naturæ*. By C. Linnæus.
 Gmelin's edition. Leipzig, 1788—1793. 9 vols. 8vo.
L'Agriculteur-Manufacturier, 8443. A French Pe-
 riodical, published monthly. United, in January,
 1834, with three others' under the Title of Re-
 cueil de la Société Polytechnique. Conducted by
 J. G. V. De Moléon. Paris, 8vo.
L'Agronome, 7989. A French Agricultural Peri-
 odical, published monthly. Paris. Begun 1833.
 imp. 8vo.
L'Institut, 8057. A French Periodical published
 in Paris. Begun 1833.
Ladies' Botany, 8056. By Dr. Lindley. Lond.
 1834. royal 8vo.
Lindley's Outlines of Horticulture, 8194. An Out-
 line of the First Principles of Horticulture. By
 Dr. Lindley, Professor of Botany in the Univer-
 sity of London, and Assistant Secretary to the
 Hort. Soc. of London. Lond. 1832. 12mo.
Main's Illustrations of Vegetable Physiology, 8056.
 Illustrations of Vegetable Physiology, &c., prac-
 tically applied to the Garden, the Field, and the
 Forest; consisting of original Observations col-
 lected during an Experience of Fifty Years. By
 J. Main, A.L.S. Lond. 1833. small 8vo.
Manuel du Fontanier-Sondeur, 8340. Par M. Gar-
 nier. Paris, 1829. pamph.
*Mémoires de la Société de Physique et d'Histoire
 Naturelle de Genève*, 8070. Published period-
 ically at Geneva. 8vo.
Moléon's Recueil Industriel, 8393. See *Recueil
 Industriel*, p. xv. United, in January, 1834, with
 three others, under the title of *Recueil de la So-
 ciété Polytechnique*, &c. Paris, 8vo.
Leeds Mercury, 8395. A weekly Newspaper, pub-
 lished at Leeds.
National Education as it exists in Prussia, 7981.
 Report on the State of Public Instruction in
 Prussia, &c. By M. Victor Cousin, Peer of
 France, &c. Translated by Sarah Austin. Lond.
 1834. 12mo.
 On the Importance of the Decomposition of com-
 mon Salt for the Purposes of Manure: whereby
 an Acre of Land is prepared for the Reception of
 any Crop, at a cost of 10s. only, 8085. An Address
 to the Owners and Occupiers of Land in Great
 Britain and Ireland, on the important Discovery,
 &c. By Henry Kemp. Lond. 1834. pamph. 8vo.
Pers., 8064. *Icones pictæ Speciorum rariorum Fun-*
gorum. By C. H. Persoon. Paris and Strasburg,
 1803. 4to.
Phil. Mag., 8460. See *Philos. Mag.*, p. xv.
*Practical Directions for the Cultivation and general
 Management of Cottage Gardens, &c.*, 8156. By
 Charles Lawrence, Cirencester. 1831. 8vo.
*Present State of the Tenancy of Land in the High-
 lands and Grazing Districts of Great Britain*,
 8410. The present State of the Tenancy of Land,
 &c., collected from a Survey made in 1828 and
 1829 by the authors, L. Kennedy and T. B. Grain-
 ger. Lond. 1829. royal 8vo.
Report of Drummond's Agricultural Exhibition,
 8334. See *Report of the Exhibition*, &c.
*Report of the Exhibition of Agricultural Produc-
 tions*, 8322. *Report of the Agricultural Exhibi-
 tion at Stirling, on the Premises of W. Drummond
 and Sons*. Stirling, 1833. pamph. 8vo.
*Report of the Stewartry of Kirkcudbright Agricul-
 tural Society*, 8113. See *The Stewartry, &c.*
Scotsman, 8348. See *Scotsman*, p. xvi.
Sinclair's Hortus Gramineus Woburnensis, 8405.
 See H. G. Wob., p. xii.
Six Months' Tour, 8196. A Six Months' Tour
 through the North of England. Lond. 1770.
 4 vols. 8vo.
Sketches, &c., 8053. Forty Sketches of North
 America. By Captain Basil Hall. Lond. 4to.
Stephens's Practical Irrigator and Drainer, 2d edit.,
 8337. *The Practical Irrigator and Drainer*. By
 Geo. Stephens, Land-drainer, &c. A new Edition.
 Edin. 1834. royal 8vo.
Sturt's Expedition into the Interior of Australia,
 8038. Lond. 1834. 8vo.
The Printing Machine, 8057. A weekly Review,
 published in London. Small fol. Begun 1834.
*The Stewartry of Kirkcudbright Agricultural Re-
 port of 1810*, 8113. The yearly Report of the
 Kirkcudbright Agricultural Society.
The Times, 8461. A London daily Newspaper.
Thomson's Chemistry, 8082. A System of Che-
 mistry. By Dr. Thomas Thomson. Edin. 1830.
 4 vols. 8vo.
Trans. Agr. Soc. of India, 8035. Transactions of
 the Agricultural and Horticultural Society of
 India. Vol. I. Serampore, 1829; Vol. II. Cal-
 cutta, 1832. 8vo.
Treatise on Road-making, 8195. A Treatise on
 Roads; wherein the Principles on which Roads
 should be made are explained and illustrated.
 By Sir Henry Parnell, Bart. Lond. 1833. 8vo.
*Treatise on Roads, wherein the Principles on which
 Roads should be made are explained and illus-
 trated, &c.*, 8196. See *Treatise on Road-making*.
Quart. Journ. of Agr., 7997. See *Quarterly Jour-
 nal of Agric.*, p. xv.
Williams's Travels, &c., 8023. *Williams's Travels
 in Italy and Greece*. Lond. 2 vols. 8vo.

LIST OF CONTRIBUTORS.

Mr. Blackadder, p. 1328; Mr. Burness, p. 1366; Mr. Capper, p. 1371; Mr. Crosskill, p. 1309; Mr. Gladstone, p. 1310; Mr. Gorrie, p. 1330; Mr. Howden, p. 1305; Mr. Lawrence, p. 1323; Mr. L. of Wilga, p. 1282; Mr. Mackenzie, p. 1324; Mr. Mallet, p. 1367; Mr. Milne, p. 1327; Mr. Philips, of Albany, p. 1296; Selim, p. 1320; Mr. Swainson, p. 1371; Mr. Thompson of Sydney, p. 1295; Mr. Wilds, p. 1321; Mr. Wrigg, p. 1377.

To these, and to any other contributors whose names may have been inadvertently omitted, we return our best thanks; and we invite them and all our readers to send us whatever farther corrections and additions may occur to them. These will be used in a Second Additional Supplement.

FIRST

ADDITIONAL SUPPLEMENT.

PART I.

HISTORY OF AGRICULTURE.

7981. — 1. *THE period which has elapsed since the historical part of the Encyclopædia of Agriculture was written, may be described as one of general peace throughout the world. In the past history of the useful arts, it has always been observed that after nations have been for some years engaged in war, when peace arrives, their energies are directed to the useful arts with redoubled force. Accordingly, we find that in Europe those nations who were longest and most ardently engaged in arms, France and England, are now the most earnestly employed in domestic improvement. At present the attention of all ranks in France is directed to the advancement of agriculture and commerce; and this may be said, in a greater or less degree, of all the other nations on the Continent. The result is rendered evident to travellers by the improved appearance of the country, and by the numerous new buildings in the towns and cities; and to those who pay any attention to foreign politics, by legislative enactments, and by the establishment of agricultural, commercial, and statistical societies. Perhaps the most extraordinary improvement which has taken place on the Continent since the peace of 1815, is the establishment of a national system of education in Prussia in 1819; and, next to this, the attempt at the establishment of a similar system in France. (See Mrs. Austin's translation of Cousin's *National Education as it exists in Prussia*.) According to this system, all the inhabitants of both countries, without exception, would be not only taught all the most useful branches of knowledge, moral, intellectual, and physical, but even initiated into the practice of gardening and agriculture, in school gardens and fields; the boys into the practice of carpentry in school workshops, and the girls into the more useful branches of housewifery. Systems of national education, more or less perfect, have for upwards of thirty years been established in Wirtemberg, Baden, Bavaria, and Austria; but that of Prussia seems by far the most comprehensive, and equally likely to improve agriculture with the system of Bavaria, according to which system also agriculture is taught at the schools. In countries like Bavaria and France, where the farms are small, and the great mass of the population labouring cultivators, the education of all must be of greater importance, in an agricultural point of view, than in countries where farms are large; and where, if the farmer himself is enlightened in his arts, the ignorance of his labourers is of less consequence, since they act under his direction. Hence, with reference to national wealth, a national system of education would be of much greater consequence to Ireland, or any other country possessing but little capital, than it could be to England, or any other country abounding in capital. There are, however, other objects than the immediate acquirement of wealth, to be attended to by the legislator; and, taking the most comprehensive view of these objects, there appears to be no measure equal in importance to that of educating all classes, without exception.*

7982. *The historical part of the Encyclopædia of Agriculture was prepared in the beginning of the year 1829, and it cannot, therefore, be expected that we should have much to add in the way of bringing down the history of each particular country from that period to the present time. The details would be of too minute and temporary a nature to be considered as history; and they would occupy far too much space for this department of our Supplement. We have confined ourselves, therefore, to giving corrections or elucidations of former statements, whether these referred to remote periods of the agriculture of a country, or to descriptions of its present state. Among the latter, the most useful will be found the account of the Dutch dairy husbandry, from § 8001. to § 8019.*

ITALY.

7983. — 288. *The olive*, we are informed by Manetti, is most expeditiously propagated by cuttings, by seedlings, and by grafting. By cuttings is the most valuable mode when the soil is good, as the plants come soonest into a bearing state. Where the soil is poor, and especially if it be rocky, seedlings are to be preferred, because they send down their tap-roots into the crevices of rocks, and thus derive nourishment and support, where plants raised from cuttings would not live. In Tuscany, the olive is very generally raised from seed, and in many situations it is grafted. In Lombardy, on the Larian Hills, trees raised from cuttings are always used, and this is the reason Manetti alleges why these trees have their trunks perpendicular to the sides of the hill, instead of perpendicular to the horizon. Some interesting discussion on this very singular appearance will be found in *Gard. Mag.*, vol. viii. p. 68. to 70.

7984. — 290. *The foliage of the vines* supplies green food for cattle. Persons mount into the trees and gather the leaves into bags, exposing, at the same time, the ripening clusters to the sun. (*Blunt's Italy*, p. 212.)

7985. — 299. *The cause of malaria*, in this and other pestilential districts of Italy, has generally been supposed to be the decomposition of vegetable matter on a moist surface. This, however, is to confound the malaria with the marsh fever. The former is now thought to proceed from a very different cause, and to be analogous to what in England is called the hay fever. It is found that, while the corn or hay crop is in a growing state in the pestilential districts, they are as healthy as any part of Italy; but that the moment the crop is cut down, or withers on the ground, the malaria commences, and continues through the autumn and winter, till vegetation becomes vigorous in the following spring. The neighbourhood of Rome, where malaria is so prevalent, "is very hilly, dry, and entirely without vegetation. For days together, one sees nothing but desolate dried-up cornfields without trees, bushes, or wood of any description. In early times, Rome was surrounded by extensive sacred woods, which were not suffered to be destroyed. At that period malaria was unknown, though intermitting fevers were well known in the Pontine marshes. The avarice of the popes, however, converted these sacred woods into gold, and so desolated the region that not a tree or wood is to be met with around Rome. With the commencement of this system of extirpation the malaria appeared, and has at length reached such a height that, yearly, many are carried gradually off by it; and in the summer months strangers and respectable inhabitants quit Rome. When we take into consideration all the phenomena of marshy districts, the conclusion does not lie far distant, that the atmosphere is in different degrees rendered unfit for human organisation, not by the passage of the water to the air, but by the decomposition and solution of vegetable substances; and that thus those various intermitting fevers, and even the plague itself, are produced. In the case of real malaria, in opposition to marsh fevers, the circumstances are different. So long as the earth is covered with living vegetables, as, for example, with corn, the air of the most suspected district is pure and healthy, and no one fears being attacked by the disease; but when the prodigious crops, which in those volcanic, loose-soiled districts are speedily brought to maturity, are removed, does the surface of the earth become dead at the warmest and most energetic period of its functions? or does not rather a portion of those substances, which were consumed by the leaves and roots of plants, now go to the atmosphere, and render it unfavourable for the breathing of man, until all is again restored to an equilibrium in higher or more distant regions? That carbonaceous matter is beneficial to the vegetable kingdom, is as well known as that it is prejudicial to the breathing process in animals. No educated person in Germany doubts the organic function of the earth, to which also the cholera itself has been ascribed; and when a more general regard to nature advances to the south, the sacred woods will again gradually surround Rome, large vine branches entwine themselves round the elms, the hills be thus again covered, and the malaria reduced within limits. The fact is not without interest, that all real malaria districts are of volcanic formation, and that they are often to be found at the boundary of volcanic and non-volcanic rocks." (*Jameson's Journ.*, vol. xvii. p. 167.) In several districts in England, the country people are liable to attacks of fever immediately after the removal of the hay crop, some individuals much more so than others. This may be considered as a species of malaria of a comparatively mild description.

7986. — 301. *Lupines* are here (Vale of Poli) chiefly sown for the sake of manuring the land. When they are full grown, they are ploughed into the earth and left to rot. On some occasions they are boiled, and laid to the roots of orange and lemon trees, and even to those of olives and vines. (*Graham's Mountains near Rome*, p. 46.)

7987. — 302. *The single stave or funis* of the Roman plough is invariably adopted; the *binæ aures*, which are two strips of wood attached to the share (which also is often made of the same material), about eighteen inches long, diverging a little from each other, and inclined to the earth at a convenient angle for laying open the furrow. (*Blunt's Italy*, p. 205.)

FRANCE.

7988. — 380. *The backwardness of agriculture in France* "is mainly attributable to the very partial spread of education in the rural districts, there being out of 40,000 communes, according to M. Dupin, 15,000 destitute of teachers; and out of 25,000,000 inhabitants who have reached a teachable age, 10,000,000 only are able to read. Now as the small independent proprietors of land amount to 4,000,000, and their families to 12,000,000 or 14,000,000 more, it is obvious that this state of ignorance must, under such circumstances, be attended with far more prejudicial effects upon production than if it existed in England, where the labourers are under the orders of about 32,000 large proprietors, and the success of cultivation consequently does not so mainly depend upon the general diffusion of knowledge. It is gratifying to find, however, that the large proprietors in France are universally desirous for the instruction of the rest, and that societies, rural schools, and model farms have been established under very favourable auspices." (*For. Quart. Rev.* 1829.) A national system of public instruction was established in 1832, and the various details will be found in the *Bulletin de la Société pour l'Instruction Élémentaire*, for that year.

7989. — 381. *Present state of French agriculture*. In *L'Agronome*, a monthly agricultural journal published in France, at the low price of five francs a year, it is stated in the first number, published in January, 1833, that in France "the colonies afford no longer the means of making a fortune; the convents do not provide a remedy for the want of foresight of parents; the system of peace, which is every day procuring more advocates among the most highly civilised of the people, no longer offers a brilliant prospect in the profession of arms; commerce and manufacture suit only particular characters; the sciences and the professions only minds privileged by nature; while agriculture alone offers unlimited scope for employment and for improvement." After enlarging on this subject, the writer goes on to state, that the business of a farmer must no longer be that of men who are not fit for any thing else; but it must be adopted by men of education, and pursued assiduously and systematically. It appears, from this and other French publications, that extraordinary exertions are making in France for the territorial improvement of that country. Among other points to which the attention of the cultivator is directed, is the necessity of feeding his men well, no less than his horses. As a proof of the advantages of doing so, it is stated that when Messrs. Manby and Wilson, from England, established their iron works at Charenton, the French workmen were not able to support labour for the same number of hours as the English did, till they adopted, like them, the practice of eating butchers' meat. Exactly the same thing has been proved respecting the Irish labourers, as compared with the English.

7990. — *Agricultural Societies in France.* This, and some of the following paragraphs are taken from a very interesting article, understood to be by Professor Macculloch, which appeared in the *Foreign Quarterly Review*, just after the historical part of our 2d edition of this Encyclopædia was printed. "The Agricultural Society of the Seine and Oise, which comprises many extensive landed proprietors, bestows, annually, medals and prizes on the small cultivators who turn their hereditary estates to the most profit, and upon the hired labourers and servants employed in large farms, who perform their work with the greatest intelligence and fidelity. A model-farm has been lately established at Roville, in the Valley of the Meurthe, about six leagues from Nancy, by M. de Dombasle, a skilful practical agriculturist. It comprises clay, sand, and gravelly soil; and the proper modes of culture are applied to each. By the improvements in ploughs and instruments of husbandry, five horses and nine oxen now accomplish at Roville more work than thirty-five beasts of burthen used to do on the same ground. With the aid of the Scotch threshing-machine, M. de Dombasle beats out, with three horses, three hectolitres and a half (upwards of an imperial quarter) of wheat, and other grain in proportion. Potatoes are cultivated with attention, and a distillery has been established for extracting their spirit. M. de Dombasle has proved what will, we think, excite some surprise, that land of a middling quality, planted with potatoes for fattening beasts, will be more productive than the richest meadow. No stronger encomium can be made on the skill of M. de Dombasle, than the fact that he has more than doubled the produce of the land: the average annual return of Roville being 59 francs per hectare (of $2\frac{1}{2}$ acres), while that of the rest of the department of the Meurthe is but $28\frac{1}{2}$ francs per hectare. At Moneyey, in the department of the Moselle, the model-farm of M. Bouchotte is famous for its breed of horses." (*For. Quart. Rev.*)

7991. "The Agricultural Society of Strasburg in 1828 commenced an experimental plantation of fruit and forest trees in Alsace; a want observable not merely in that department, but throughout the whole country, except, perhaps, Normandy and parts of Britany. In Franche-Comté, and the department of Doubs, the government has taken the breeding of cattle under its peculiar care, and established annual exhibitions and prizes. In these parts, as also in Montbéliard, the useless practice of feeding off the land is beginning to be discontinued, it being ascertained that a hectare of inclosed ground produces one third more if not subjected to this ceremony. The arrondissement of Montbéliard has abandoned the system of fallows in use in the rest of the department, and cultivates with success both flax and the turnip. In Franche-Comté the very beggars are becoming industrious; they go about collecting manure till they have accumulated a certain quantity, when they take it to a proprietor, who allows them in return to plant on his soil, and receive the crop of a proportionate number of potatoes. In Picardy, the increase of the sheep-flocks, and the improved system of manuring, have added to the fertility of the soil. At Nouvion, in the department of the Aisne, the farms have been ornamented by hedges and plantations, in imitation of the adjoining country of Hainault. It is here that the making of sabots, and wooden utensils called bois-jolis, is chiefly carried on; the supply sent to Paris annually is valued at 17,000*l.* At Origny, in the neighbourhood of Vervins, the children of the husbandmen are employed in fan-making, baskets, &c. of willow, to the value of 40,000*l.* per annum. In Champagne, the example of M. Richardot, a small proprietor, has given an impulse to planting, and to a systematic irrigation of the land." (*Ibid.*)

7992. — 390 & 414. "The culture of the vine is a department of their husbandry of which the French have, perhaps, a right to boast more than any other people. The same grape, when tried in countries under the same latitude as the south of France, has never been brought to an equal degree of perfection. The plantations of vines have been and are subject to severe discouragements, but have, nevertheless, increased very considerably over their extent in 1789. In that year their surface was estimated at 1,200,000 hectares of land; in 1808, it amounted to 1,600,000; and in 1824, it covered 1,728,000 hectares. In 1828, the vines occupied about 2,000,000 cultivators, and their annual produce was computed at 40,000,000 hectolitres; the value of which, at fifteen francs per hectolitre, is 600,000,000 francs, or about 24,000,000*l.* sterling English money." (*Ibid.*)

7993. — 391. *The olive climate.* Strabo (lib. iv.) says, that the line of the Cevennes, in Gallia Narbonensis, was the northern limit, beyond which the cold prevented the growth of the olive. The limit is still in the same position. (*Jameson's Jour.*, April, 1834, p. 233.)

7994. — 398 & 399. *The breed of cattle and sheep in France,* "with the exception of parts of French Flanders, Normandy, and Alsace, is yet very degenerate. But their improvement, like that of mankind, depends upon their rearing; and, if the example of the Roville and other studs be followed, there seems no reason to doubt that the French horses may one day equal those of England or Spain. The company lately formed for recovering the 4,000,000 hectares of marsh land now uncultivated, and converting them into pasture, will greatly further the amelioration of the cattle, as well as the augmentation of their numbers. 2,500,000 horses, 7,000,000 horned cattle, and 42,000,000 sheep and goats, are certainly not a large stock for a country covering 53,500,000 hectares of land. The most experienced of the agriculturists have shown that the fleeces may be brought to almost any desired degree of perfection. When the merinos of Spain first appeared in France, the partisans of the coarse mattress-wool were continually alleging that Spanish sheep would never thrive in the French climate; their success has, however, been complete. The celebrated M. Ternaux (deceased in 1832) imported wools of what are called the electoral race, and placed the goats of Thibet in his park of St. Ouen, near Paris. The rugged declivities of the Jura have been adorned with the magnificent naz breed of MM. Girod and Perrault, and their rams are now attesting in New Holland the march of science in the management of flocks in France." (*For. Quar. Rev.*)

7995. — 403. "The French pigs, although they have excited many facetious observations from travellers, and have not unfrequently been compared to greyhounds, may be fattened, we are assured, at a small expense; and the method of doing this is now beginning to be better understood. The Chinese and English breeds are also getting into use for crossing. The fact that 4,000,000 pigs are killed yearly in France, shows of how great importance they are to the small agriculturist." (*Ibid.*)

7996. — 407. *The most extensive of the branches of French agriculture, as connected with the manufactures,* "are the culture of beet-root for sugar; of oleaginous plants, particularly at Lille and Dijon; and of the mulberry for silk-worms, in Languedoc and the southern provinces. It has been the habit in England to consider the former of these as merely a fanciful amusement of national vanity; but it appears by the amount of its consumption (between 7,000,000 and 8,000,000 lbs. a year), that at all events it is become an article of some practical magnitude." (*Ibid.*)

HOLLAND.

7997. — 426. *The greatest part of the land in Holland,* it is observed by Mr. Aiton, of Hamilton, being under the level of the sea, and of the great rivers and canals which intersect that country, and, consequently, being unfit for arable culture, is generally kept in meadow. "Part of the grass produced is cut for hay, to supply the stock in winter and spring; and the rest of it is eaten off by a few sheep and horses, but chiefly by cows. Some of the cows are fattened for the shambles, but most of them are kept as dairy stock. In those parts where the surface of the ground is above the level of the water, it is cropped with wheat, rye, rape, beans, oats, flax, hemp, and potatoes: and even where the soil is a little lower than the level of the sea and rivers, part of it is dug up in some places, and cropped with potatoes, hemp, &c. But the greatest part of North and South Holland is so often overflowed with water, as to render it improper to raise winter wheat crops to a great extent." (*Quart. Jour. of Agr.*, vol. iv. p. 328.)

7998 *The soil* "being generally rich, the herbage is luxuriant; but, owing to the moist condition of

the land, which is frequently inundated in winter, the herbage it produces is rather coarse, and many moist plants arise from the richer natural grasses." (*Ibid.*)

7999. *There are few large estates in Holland*, and "but few large farms. The land being remarkably level, it is generally divided and subdivided by ditches, or narrow canals, that receive the surface water, and serve the purposes of a fence." (*Ibid.*)

8000.—428. *The farm-houses in Holland* "are of dimensions suited to the extent of the land in the farm, and they are more or less elegant or comfortable, as the wealth or taste of the occupant may dictate; but they very much resemble each other. They are generally of only one story in height, but placed on so broad a base, as to afford accommodation not only for the boor, or farmer, and his family, but also their live stock, dairy, cheese-house, threshing-floor, the whole crop, and fodder for cattle. In short, the whole farmstead is frequently comprehended under one roof. Besides a kitchen, in which the family sit and eat, as well as cook their food, and from which they can see their cattle during winter and spring, these houses contain at least one elegant and well-furnished room, with a bed-room or two, into which they seldom enter, except on days of festivity. Their kitchens are much more tastefully fitted up than those of the farm-houses in Scotland. They have a stove of an elegant figure, which is kept wonderfully clean. The wall near to the fire-place is covered with plates of flowered earthenware; and the mantel-piece is richly, though rather heavily, fitted up. There are some concealed beds and closets in this part of the building; while a pump-well, and a horse-gin for washing and churning the butter, are both at hand, near the centre of the building. The floor of the kitchen generally consists of marble; the rest of the building is of brick. The gincourse is laid with sand, and is covered with boards when the horse is not in yoke. The whole building is roofed with tiles, and the roof rises in a somewhat pyramidal form. The walls are generally built of brick, but sometimes of mud or boards; but the roof is supported on frames of wood, round which the walls form only a covering. There is no urine tank as in Belgium. Indeed, little attention seems to be paid to manure in Holland, probably on account of the soil being naturally rich." (*Ibid.*)

8001. *The cow byre* is "paved with hard bricks, or clinkers, as they are termed, set on edge; and the stakes to which the cows are bound are made to be removed in summer, when the cattle are turned out to pasture. A passage before the cow's head is convenient for giving them their meat, and a trough of clean water is placed before the cows, from which they can drink at pleasure. The water is let off once a day by means of a plug, and a new supply from the well pumped into the trough. A passage behind the cows serves to remove the dung." (*Ibid.*, p. 330.)

8002. *Dutch cows*. "The Vriesland and Gröningen cows are the largest and most esteemed races in Holland. They are short-necked, broad and deep-chested, deep-bodied, and broad-backed, with well-made limbs, fine small horns, and stand well upon their feet. The greatest number of these cows are either black or white, or dark brown and white." (*Highland Soc. Trans.*, vol. x. p. 169.)

8003. *The general practice in Holland* is, "that the cow should calve in her second year. The bull is employed when it is two years old, and is fattened and sold to the butcher when four or five years old, and the cow at seven or eight. Some cows are, however, kept for milking till the tenth year." (*Ibid.*)

8004. *The most improved method of treating the calf in Holland*. "It is immediately after its birth taken from the cow, put in a separate place, and laid on dry straw. A little salt is given, and the tongue and mouth are rubbed with it. It is also rubbed clean with straw. After the lapse of six or eight hours, the first beasting of the mother cow, diluted with one third water, is given to the calf to drink, and this treatment is continued for some days, the liquid being given thrice a day. Thereafter, during two or three weeks, they give the calf the milk as it comes from the cow, diluted with one fourth water, in which now and then a small handful of salt is put; then buttermilk is gradually given, and it is supplied with hay; at the age of ten weeks it is brought out into the meadow, where it is also supplied with skimmed milk, buttermilk, or whey. In this way each farmer raises the proper number of heifer calves to fill up vacancies; but calves fattened for sale have milk from the cow three times a day. For some days after calving the cow is milked thrice a day, after which they return to the usual practice of milking twice a day." (*Ibid.*)

8005. *Treatment of milch cows in Holland*. "The cows are turned out to grass generally by the end of March, or the beginning of April. They are, when first sent out, furnished with a very thick cloth of tow, covering the back and sides, from the shoulders to the tail, to prevent diseases from cold. They remain out, night and day, about thirty weeks. In the winter months the general food is hay, and most farmers give their cows nothing else: distillery grains are sometimes given, when they can be obtained. At the great establishment of Baron Van Palink, near Leyden, boiled beans, with rape cake, spread over the hay, were given at night, and ground linseed cake in the morning, which, it was stated, enabled the cow to give more and better milk than hay alone. Raw potatoes and dry linseed cake are also sometimes given, and most farmers give the buttermilk, either diluted with water or not, to the cows, as well as to the calves and pigs. Mangold-wurtzel is also given, but turnips never." (*Ibid.*)

8006. *The byres or cow houses in Holland* "are generally lofty, airy, paved with large square bricks [Aiton says "clinkers," see § 8001.], and kept perfectly clean. The roof is generally about ten feet high. There are no racks or mangers. The cows stand in two rows, generally facing the centre, and sometimes the sides of the byre, along which is a brick pavement slightly elevated in the middle. On the edges next the cows, and on a level with them, is a trough, perfectly clean, into which the meat or drink is put, and the hay laid down. Each cow has about five feet of space, and is tied to a railing of three small posts in front, which separate them from one another. There is little straw used for bedding: on the place where the cows stand, there is a hollow part at the fore feet, into which are now and then put dry horse dung and straw; at the hind feet, generally nothing is laid but a little dry sand. From the narrowness of the space divided into stalls, the back always projects so far as to cause the dung droppings to fall into a gutter about eighteen inches deep, and eighteen inches wide, which is regularly and carefully swept and cleaned, so that there is very little trouble in clearing away and collecting the manure. The cows are always kept quite clean; and, to prevent the tail occasioning filth, the lower end is always tied up by a string attached to the ceiling." (*Ibid.*)

8007. *Process of milking in Holland*. "The cows are always milked by the men, and the butter and cheese made by the women. One man is considered necessary for every ten cows. At Ter Leide, the well-managed dairy establishment of Baron Van Palink, there are ninety milch cows, nine men, and a *Boerinn* (or female farmer), the maker of the butter and cheese, who has a female assistant. At Klinkenburgh, near Sasenheim, there are forty cows; the farmer and three grown sons do all the milking, and his wife and one female servant make all the butter and cheese. At Schoote, near Haarlem, there are twenty cows; the father and son milk, and the wife and a female servant make the butter and cheese." (*Ibid.*)

8008. *Butter*. "There are three distinct kinds of butter manufactured in Holland; the butter made from the cream, when the cow is at grass in the summer, called grass butter; the butter from the whey of the new milk cheese, called whey butter; and the butter made in winter, when the cows are in the cow-houses, called hay butter." (*Ibid.*)

8009. *Grass butter*. "The cows being carefully milked to the last drop, the copper pitchers lined with brass, or pitchers entirely of brass, which contain the milk, are put into an oblong water-tight pit, which they call a *roelbak*, built of brick or stone, about six feet in length, three feet in breadth, and two feet in depth, into which cold water had been previously pumped; there being generally a pump at one end of the pit. In this pit or cooler, the pitchers stand two hours, this milk being frequently stirred. The cooling process is of great advantage in causing the cream to separate rapidly and abundantly from the milk. After this, the milk, being run through horse-hair sieves or drainers, is put into the flat milk-dishes,

which are of earthenware, copper, or wood, as will be afterwards described; it remains in a cool dairy or cellar for twenty-four hours. It is then skimmed, and the cream is collected in a tub or barrel. When soured, if there is a sufficient quantity from the number of cows, they churn every twenty-four hours, the churn being half filled with the soured cream. A little boiled warm water is added in winter, to give the whole the proper degree of heat; and in very warm weather the cream is first cooled in the *roelbak* or cooler. In many small farm-houses, or when the cows give little milk, the milk is not skimmed; but the whole, when soured, is put into the churn. The butter, immediately after being taken out, is put into a shallow tub called a *vloot*, and carefully washed with pure cold water. It is then worked with a slight sprinkling of small salt, whether for immediate use, or for the barrel; there being none made entirely without salt, as in Scotland. When the cows have been only eight or ten days out, the difference between grass and hay butter is slightly perceptible; but the grass butter, after the cows have been three weeks at grass, is delicious. This new butter is highly esteemed in Holland: it is made in fanciful shapes of lambs, pyramids, &c., or stuck with the flowers of the polyanthus, &c., and sells very high. If intended for barrelling, the butter is worked up twice or thrice a day with soft fine salt, for three days, in a flat tub, there being about two pounds of this salt allowed for fourteen pounds of butter; the butter is then hard packed in thin layers into the casks, which casks are previously carefully seasoned and cleaned. These casks are always of oak, well smoothed inside; and, before being used, they are allowed to stand three or four days, filled with sour whey, and are then carefully washed out and dried. Each cow, after being some time at grass, yields about one Dutch lb. (seventeen oz. and a half) of butter per day." (*Ibid.*)

8010. *Hay butter* "undergoes the same process as grass butter; being, of course, the butter made in winter, when the cows stand in the cow-house. But, although inferior in flavour and colour, it has none of the disagreeable taste which the turnip imparts to the winter butter of Britain." (*Ibid.*)

8011. *Whey butter* "is made from the whey of the new milk cheeses. The whey, being collected from the curd and the pressed cheese, is allowed to stand three days or a week, according to the quantity; the cream is either skimmed off and churned, or the whey itself is put into the churn, and the butter is formed in about an hour. In winter the butter obtained by this process is about one lb. per cow per week; and in summer about one lb. and a half per cow per week." (*Ibid.*)

8012. *Cheese*. There are four kinds of staple cheese made in Holland: the round or bullet cheeses, called Edam (from their having been first principally made in that neighbourhood); Stolshe (so called from the village of Stolkwyk), which are called in Britain, Gouda, and are flat, and broader and larger than the Edam, both kinds being made of unskimmed milk; Leidsche or Leyden (being so called from this kind of cheese being principally made near Leyden), which is made of milk once skimmed; and Graawshe, which is made in Vriesland, of milk twice skimmed. Both the latter kinds are called Kanter cheese in Britain, and are larger and flatter than the two first named." (*Ibid.*)

8013. *Edam cheese*. "The process of manufacture of the Edam cheese is as follows:—The rennet is put into the milk as soon as it is taken from the cow; when coagulated, the hand, or a wooden bowl, is passed gently two or three times through the curd, which is then allowed to stand a few minutes; the bowl or finger is again passed through it, and it is permitted to stand some minutes longer. The whey is taken off with the bowl, and the curd is put into a wooden form of the proper size and shape of the cheese to be made. This form is cut out of the solid wood by a turner, and has one hole in the bottom. If the cheese is of the small size (about four lbs.), it remains in this form about fourteen days. It is turned daily, the upper part, during this time, being kept sprinkled with about two ounces of purified salt of the large crystals. It is then removed into a second box or form of the same size, with four holes in the bottom, and put under a press of about fifty lbs. weight, where it remains from two to three hours, if of the small size; and four to six hours, if of the large size. It is then taken out, put on a dry airy shelf in the cheese apartment, and daily turned for about four weeks, when Edam cheeses are generally fit to be taken to market. Alkmaar, in North Holland, is the great market for Edam cheese. It is not uncommon to see 800 farmers at this market, and 470,000 cheeses for sale on one day." (*Ibid.*)

8014. *Gouda cheese*. "This kind of cheese is also made from the milk, immediately on its being taken from the cow. After gradually taking off the principal part of the whey, a little warm water is put upon the curd, which is left standing for a quarter of an hour. By increasing the heat and quantity of the water, the cheese is made harder and more durable. All the whey and water is then taken off; and the curd is gradually packed hard into a form, cut out by the turner, flatter and broader than the form for the Edam cheese. A wooden cover is placed over it, and the press, with a weight of about eight lbs., put upon it. It is here frequently turned, and remains under the press about twenty-four hours altogether. The cheese is then carried to a cool cellar, and put into a tub containing pickle, the liquid covering the lower half of it. The water for the pickle is boiled, and about three or four handfuls of salt are melted in about thirty imperial pints of water. The cheese is not put in until the water is quite cold. After remaining twenty-four hours, or, at most, two days, in the pickle tub, where it is turned every six hours, the cheese, being first rubbed over with salt, is placed upon a board slightly hollowed, having a small channel in the centre to conduct the whey, which runs off into a tub placed at the one end. This board is called the *zouttank*, and several cheeses are generally placed upon it at a time. About two or three ounces of the large crystallised salt is then placed upon the upper side of the cheese, which is frequently turned: the side uppermost being always sprinkled with salt. It remains on the *zouttank* about eight or ten days, according to the warmth of the weather; it is then washed with hot water, rubbed dry, and laid upon planks, and turned daily, until perfectly dry and hard. The cheese-house is generally shut during the day, but must be open in the evening, and early in the morning. Each cow at grass in Holland is calculated to give about three or four lbs. of new milk cheese per day." (*Ibid.*)

8015. *Kanter cheese*. "The skimmed milk is poured out of the stone, copper, or wooden milk dishes, into a tub or tubs, in which it remains to settle half a day. About the fourth part is gently poured over into a copper boiler; which boiler, by the most careful farmers, is oiled with sweet oil, to prevent burning the milk, or giving it a singed taste. This is heated till the hand can hardly bear the heat, and then taken out and mixed with the other three fourths, the whole being stirred about; the rennet is then put in, and when coagulated, the whey is taken out with a wooden bowl, the curd is hard worked and pressed with the hands, and then put into a cloth, the four corners being folded on the top, and the whey pressed out. The curd is next put into a broad tub, called a *porteltobbe*, and hard worked, and trodden upon by the bare feet; for although there has lately been a plan introduced to obviate this disagreeable practice, this is generally the mode used in making common or kanter cheese. The next process is to mix among the curd a shut handful of soft fine salt to every thirty lbs. of cheese. The curd is then put into a strong circular form (of staves, and hooped, about three inches thick, with holes bored in the bottom), with the cloth round it. It stands in this form twenty-four hours, the cloth being taken off and wrung dry three or four times a day during these twenty-four hours: this form is placed upon a hand-barrow, or open standard, over a tub, which receives the whey; a cross plank is laid over the lid of the cheese form, and it is frequently pressed by the weight of the body. The cheese is then taken out and put into a cheese-well, or form, equally strong, having a cover called a *volgirt*, and put under a heavy press, the weight being about 360 lbs., where it remains twenty-four hours more. After this process, or when taken out of the press, the cheese is washed, and in some places it is smoothed by rubbing it frequently with sour skimmed castings preserved for the purpose; it is then rubbed with a reddish-coloured substance, called *kaasverf* or *kaasmeer*, which the apothecaries sell in Holland, for the purpose of giving it a smooth outside, and good colour. The cheese is then put into a cool cheese-house or cellar, and frequently turned, until brought to market. It is into this kind of common or kanter cheese that various spices are put, although few of the spiced cheeses come to this country. This operation takes place when the curd is put into the first form: the curd is put in layers; the first layer has no spices in it, but upon it is sprinkled

some cummin seed, and then follow regular layers, with cloves intermingled, until the upper layer is placed, which has no spices in it." (*Ibid.*)

8016. *Graawshé kaas, or inferior kanter cheese.* "This inferior kanter cheese is made of milk twice skimmed, in Vriesland and Gröningen; and is prepared in a similar way to Leidsche, or the best common or kanter cheese, to which it is much inferior. The Dutch farmers reckon that thirty cows at grass will give from 100 to 200 lbs. of fine butter, and about 300 lbs. of kanter or common cheese, per week." (*Ibid.*)

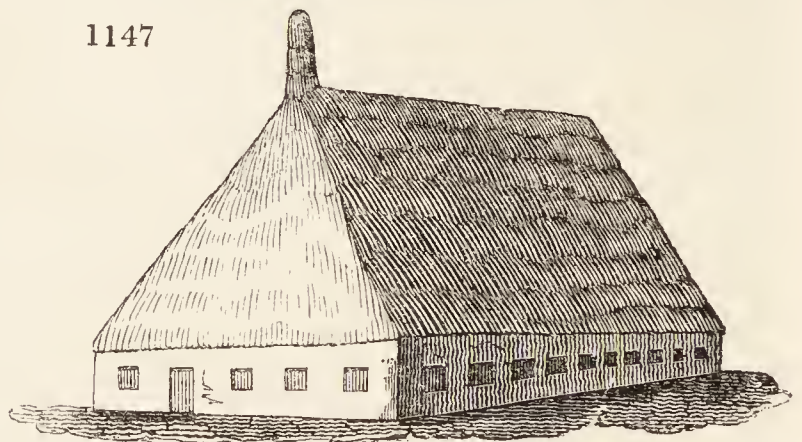
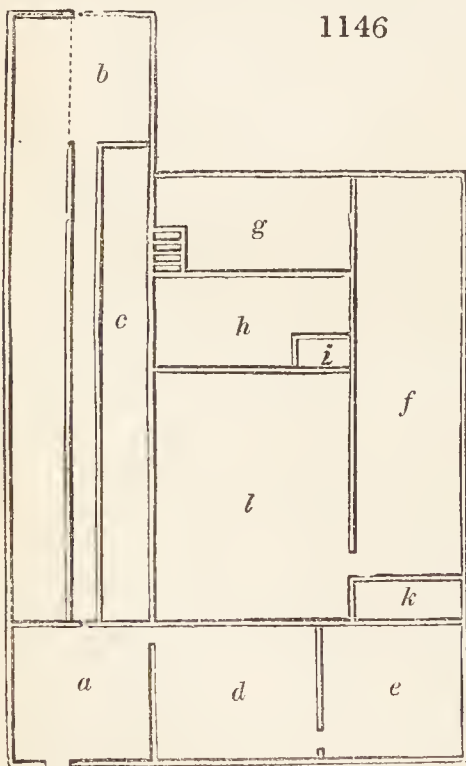
8017. *Dairies, or milk-houses.* "There is great variety in the arrangements of the milk and cheese-houses; but the most frequent form is this:—Between the dwelling apartments and the cow-house, and of the breadth of the house, is a square apartment for churning and other similar operations; at one corner is the cooler, built of brick, as already described, and generally having a pump at one end, for the purpose of introducing the cold water to cool the milk. This apartment is airy, roomy, and paved with square bricks. Descending a few steps from it, is the milk-house, or rather cellar; it is always three or four steps below the level of the house, paved with brick, and having an arched ceiling, almost always of brick or stone, and two or four windows, according to size. The milk dishes, or pans, which are daily first hand scrubbed and washed with boiling hot water, and then with cold, are ranged along the floor (not on shelves), in such a way as each pan may be reached by the dairy-maid. The windows are opened or shut according to the state of the weather, to which particular attention is paid." (*Ibid.*)

8018. *The cheese-houses* are also generally cellars, and adjoining the milk-houses; but in summer the byres are used for the Leidsche or kanter cheese; the floor being kept quite clean. All the windows and doors being open, abundant air is afforded. In winter the windows of the cheese-houses are generally kept shut; and, if any intense frost exists, they put in one of the wooden boxes, containing a pan with burning turf. The cheeses are placed in rows on the wooden shelves." (*Ibid.*)

8019. "The sweet and delicious flavour of the Dutch butter is said to be principally owing to the excellence of the Dutch salt. The butter, though salted, is always well flavoured, and hardly tastes of that acrid quality which the muriate or sulphate of magnesia frequently imparts to butter in this country. This acidity will be found very obvious, when comparing the Dutch salted butter to the best salted butter of Britain. It appears that in the manufacture of salt more time is allowed for evaporation and crystallisation, and that the crystals are nearly an inch square. In Britain the process of evaporation is hurried on by artificial heat, so that the crystallisation is never perfect. This is owing to our excise laws, which it is to be hoped will be removed, or regulated in such a manner as to admit of applying the modern improvements in chemistry in this manufacture." (*Ibid.*, vol. x. p. 184.)

8020. *The great cleanliness everywhere observable in the farmeries of Holland* is "another cause of the general excellence of the dairy produce. This seems to be the result of a well-regulated division of labour. The men attend to milking and feeding the cows, and the women to making the butter and cheese. As to cleanliness, every dwelling-house is a model and a pattern; the inhabitants seem to vie with each other on this point. The cow-house is pure and clean, not a particle of filth being to be seen in it; the cows are as clean as if they were in a dining-room; the milk and cheese-houses, and, in short, every part of the house, are free from dust and dirt of any kind; the manure is placed at a convenient distance from the cow-house, behind the house, and every particle is carefully collected together. The whole apartments, even the byre and hay-house, are generally under one roof; and the cleanly system, and the admirable arrangements, give that comfort and pleasure which are too often wanting in Scotland." (*Ibid.*)

8021. *As an example of a Dutch dairy farmery*, we copy the plan and elevation, *figs.* 1146 and 1147. In *fig.* 1146., "a is the kitchen or living-room of the family, during the greater part of the year; b, a temporary



Holland are generally of one story, and thatched with reeds, as in *fig.* 1147., one immense, lofty roof covering the whole. The highest part of this roof is in the centre, over the hay and straw room. (*Ibid.*) Mr. Aiton of Hamilton, who also visited Holland with a view of studying its dairy husbandry, gives a similar account of the Dutch farm-houses. See § 8000.

GERMANY.

8022.—567. *The Agriculture of Prussia.* The system of national education established in this kingdom in 1819 has been already mentioned, and the reader will find the details, which have reference to the manner in which agriculture is taught in the school gardens or fields, in Cousin's work already (§ 79. 81.) referred to.

8023.—573. "The farmers about Bonn," says Williams, "have neither a good plough, nor a good cart, and their hay-fork is like Neptune's trident." (*Williams's Travels, &c.*)

8024.—624. *Screens or narrow barns* are used in many parts of Carniola for hanging buck-wheat upon. The screen is composed of two upright posts, twenty feet in height. Through holes in the upright posts, horizontal poles are placed, reaching from one upright to the other. On these poles, the buck-wheat and other kinds of fodder are placed. A narrow roof of boards covers the whole, passing from one upright to the other. The sheaves of buck-wheat are also sometimes fixed on an upright post. (*Cadell's Travels, p. 24.*)

8025.—625. *Gourds* are cultivated in considerable quantities in Carniola and Styria: cut in slices, they are given to the hogs and cows. (*Cadell's Travels, vol. i. p. 25.*)

RUSSIA AND POLAND.

8026. — 662. *Roads in Poland.* By far the best specimen of that kind of road usually called macadamised, for want of a more explicative term, is to be found between Warsaw and Kalisz, a distance of thirty-three and a half Polish, or one hundred and fifty-six English miles. Throughout this distance it is uniformly hard, level, and as smooth as a billiard table, quite straight, planted with a double row of trees on each side, and with very tolerable inns at each post station. It is doubtful whether a better road is to be found in England; certainly not on the Continent, except, perhaps, between Milan and Cremona, or even as far as Vicenza. The Warsaw road is perfectly new, and owes its existence to the grand duke Constantine, whose efforts to improve the internal communication of the country in every direction were incessant. One feature of the Polish road in question deserves notice, because it tends to give it the appearance of a carriage-road in a gentleman's park kept in the highest order; namely, the manner in which the sides are dressed all along with green turf, which looks like mossy banks, cut smooth, and perfectly level. This method of flanking a macadamised road that has been cut through hills, or prominent undulations in the ground, offers, besides its neat appearance, a great advantage; for it prevents, in a great measure, the carrying away of the loose earth and denuding of the roots of trees during heavy rains, both which inconveniences, very injurious to the road itself, takes place when the sides are not covered with turf. (*Granville's Russia*, p. 580.)

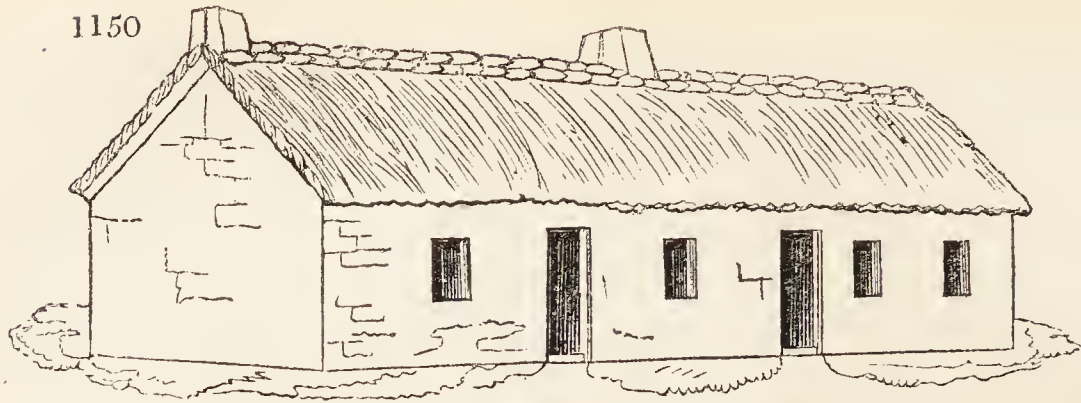
8027. *British farmers in Poland.* Since the peace of 1814, some Scottish farmers have settled in different parts of Poland, and chiefly in the neighbourhood of Warsaw. The soil and the climate are found much more favourable, both for agriculture and gardening, than might naturally be imagined. Though the winters are more severe than they are at Edinburgh, yet the summers are much warmer, and corn and fruits ripen much sooner and better. The cucumber grows freely, and bears abundantly in the open air during the summer months. The estate or farm of Wilga, on the river of that name, a view of which is given in *fig. 1148.*, consists of 1800 acres, and was purchased by a near relative of the author



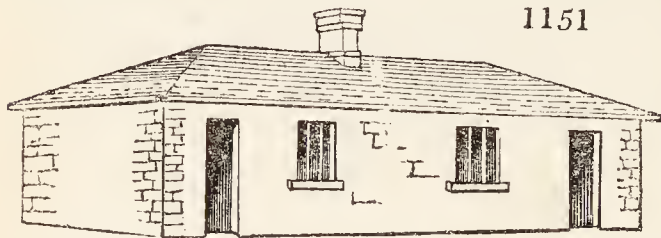
g *b h a c e d f*
 in 1832. The buildings consist of a dwelling-house (*a*), with a detached kitchen (*b*), a brewery (*c*), a distillery (*d*), a machine for raising water to supply both (*e*), a corn-mill (*f*), sheds for feeding cattle (*g*), an ice-house (*h*), in which ice is kept above ground by means of thick double walls and doors; and large barns, a threshing-machine, coach-house, stabling and all other offices, including a carpenter's shop and house, blacksmith's shop and house, bailiff's house, &c. Besides these there is a small colony of cottages for the common labourers. These cottages are generally of the kind called log houses, and, with their draw-wells attached, present the appearance of *fig. 1149.* The Germans who are settled in Poland, as agricul-

1149





turists, generally build thatched cottages in the style of *fig. 1150*; and the English in the neighbourhood of Warsaw adopt the style shown in *fig. 1151*. Behind the house there are a large garden and orchard, with summer-house, green-house, &c., the estate having been the property and residence of a Polish nobleman, considered a man of taste. The situation of this property is about thirty miles from Warsaw, in



a flat country, and there is good communication between it and that city, both by land and water. The soil is light in most places, but in others it is loamy. About half the surface is covered with wood, chiefly birch, poplar, and Scotch pine, which is felled at stated intervals, and is floated down the Wilga and the Vistula to Warsaw, where it is sold as fuel. The culture pursued on the arable land is the convertible system of—
1. turnips; 2. corn, chiefly barley and wheat; 3. clover; and 4. oats. The turnips and clover

are consumed in the feeding-houses by milch cows, or cattle for the butcher. The corn is either ground into flour, or malted and brewed into beer, or distilled into spirit; for both of which there is an ample market at Warsaw. Butter and cheese are made, for which there is also a great demand. Pigs are fattened, but the Polish towns being chiefly occupied by Jews, and trade of every kind being chiefly in their hands, it is found that pigs cannot be driven to market, and sold there alive as in Britain; but the carcasses are salted, or cured as bacon, and sold in that state, to Christian consumers. The fattened cattle are sold by private contract to Jewish dealers, who dispose of them, either to their brethren in Warsaw, Cracow, and other towns in Poland, where they are killed in the manner peculiar to the Jews; or to Christian butchers either in Poland, Prussia, or Russia. Numbers are sent to Dantzic and other sea-port towns. An unlimited supply of manure may be obtained from Warsaw at present, though it cannot be expected that this will long continue to be the case; but bones are abundant not only in Warsaw but all over the country, and the supply of this manure will, probably, for many years, exceed the demand. A crushing-mill has been, or is about to be, added to the corn or flour-mill on the estate. It is also in contemplation to establish a steam-boat between Wilga and Warsaw, which will add greatly to the rapidity of conveyance between the two places. The flour might then be converted into bread, and the cattle, for Christian consumption, slaughtered on the farm; for it is chiefly by manufacturing farm produce, that it can be at all disposed of to advantage in such a country as Poland. The great drawback to farming in Poland, is the want of moral principle in the labourers, who require continual watching both to keep them at work, and from stealing and drinking; but as this has arisen from the harsh treatment to which, as slaves, they have been subject from their masters through many generations (see § 650.); it may be diminished by kindness to the adults, and the education of the children.

8028. — 672. *Food of the peasantry in Russia.* Rye bread is the chief support of the peasants in the north of Russia; but, in order to save the rye flour, and to make it last the longer, the inhabitants, when compelled by necessity, mix with it fine ground oatmeal, the meal of buck-wheat, and the husks of the field mustard seed (*Sinapis arvensis*). Brandy is, in general, distilled in Russia from rye meal, with a more or less additional quantity of barley, oatmeal, and barley malt; but very seldom from wheat, or buck-wheat. The Russians also distil brandy from potatoes, juniper berries, and *Sorbus aucuparia*, at all times with an addition of meal and malt. They distil, in Astrachan, a sort of French brandy from damaged wines, prunes, kernels of cherry-stones, and wild almonds (*Amygdalus nana*). Some of our distillers make use of the skin and stalks of pressed grapes, raisins, and the waste in sugar refineries, with which they make good brandy. To the worst and common sorts of brandy belongs the dram of Kamtschatka, of *Heracleum Sphondylium*, and another used by the Kalmucks, made from sour distilled mare's milk, which is spirituous, but rather of a disagreeable flavour. (*Com. Board Agr.*, vol. i.)

8029. *Agriculture in Livonia.* The country, before reaching Volima, offers a tolerable specimen of the present state of agriculture in this part of Livonia. Forests, both old and new, in considerable numbers, are met with here and there, succeeded by corn fields; barren heaths; farm-houses, consisting of one or two wooden buildings, and a yard, in tolerably good condition; small horses, and diminutive horned cattle; no inclosures, except a kind of palisade, marking the divisions of property or protecting the farm-houses from intrusion; and extensive buildings serving as granaries to hold the crops. These are the most prominent agricultural features of the country. The Livonians have the reputation of being good farmers. (*Granville's Russia*, p. 397.)

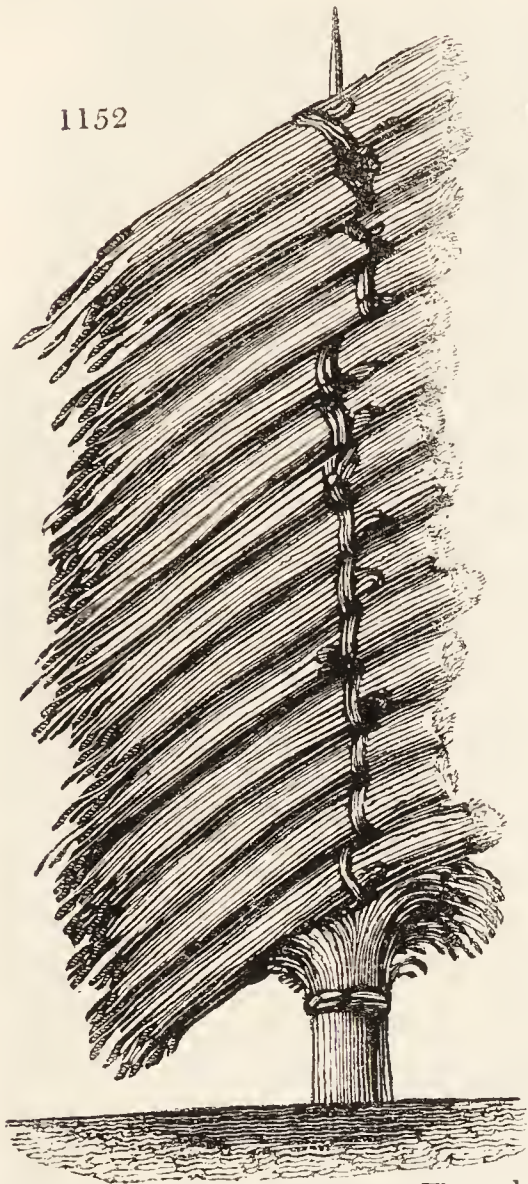
8030. — 673. *Agricultural products of Russia.* The hop is indigenous in the district of Petersburg; a few are also cultivated in gardens, and the crop gathered the end of September. Hemp is sown about the middle of May, and pulled up in the beginning of September. Flax is sown in the beginning of June, and pulled in the middle of August. Both these plants are grown only in small quantities for private use. Red clover is sown along with barley and oats, and cut the following year, about the end of June, and the second in September; the plants are frequently destroyed by the early frosts. The farinaceous plants grown in the district of Petersburg are the following:—Some winter wheat upon good soil, sown in the latter end of August and the beginning of September, is reaped about the middle of August. Spring wheat is sown on newly cleared lands in the beginning of May, and reaped about the middle of August. Rye is sown, more extensively than any other grain, on most descriptions of soils, and in the latter end of July and the whole month of August; it is reaped the latter end of July and the beginning and middle of August. Spring rye is sown upon high and sandy ground in the beginning of May, and reaped the latter end of August. Barley is sown in the beginning and middle of May, and reaped about the middle of August. Oats are sown the latter end of April and beginning of May, and reaped from the middle of August to the beginning of September. Buck-wheat is sown upon high sandy lands in the month of May, and reaped in the beginning and middle of September. No oleaginous plants are cultivated, except the sesamum and the white mustard in a few gardens. The following are the leguminous plants of the same district:—White and gray peas are sown in the beginning of May, gathered green the latter end of July, and ripe the latter end of August. Beans are sown in the beginning of May, and reaped in the middle of August: French beans are sown in gardens, but they seldom do much good. (*Com. Board Agr.*, vol. i.)

SWEDEN.

8031. — 688. *General appearance of the country in Sweden.* A bishop of Bergen is said to have given the name of Northern Italy to some districts of Norway and Sweden. The pine forests are very beautiful, especially when the pale green of the young shoots contrasts with the older foliage. From the appearance of some of these trees on lofty cliffs, it is easy to perceive how in alpine countries the descent of the roots of the pine and the mountain ash, through fissures, contribute to the splitting of the rocks. The Swedish milestones are raised on plinths to keep them above the snow. The roads, winding through extensive pine forests, are picturesque in the extreme. (*Brooke's Travels in Sweden.*)

8032. — 693. *The cottages of the peasants in Norway* have double fronts. This additional protection renders them warm and secure against the blasts of winter. The manner of building these cottages is the same as in Sweden: and on the roof of each, a luxuriant crop of grass is generally growing, though some were loaded with a thick coating of pebbles, and above them were two or three large fragments of rock, to securc the whole from being blown away by the winter storms. (*Brooke's Travels*, p. 105.)

8033. — 704. *Stakes for drying newly-cut corn* are also used in Sweden. They are generally made of young pine trees, eight feet long, about one inch and a half in diameter at the top, and four inches at the bottom. Both ends are pointed, and the thick end is let into the soil by the aid of an iron crow bar. The first sheaf is put on the stake with the root ends of the corn downwards, and the other sheaves, to the number of fifteen or sixteen, are placed in an inclining position, as shown in fig. 1152. (*Quart. Journ. Agr.*, vol. iii. p. 638.)



which surround every hovel. These hovels are clean and comfortable; and wages are high, while food is cheap. (*Fraser's Persia*, *Edin. Cab. Lib.*, vol. xv.)

PERSIA.

8034. — 864. *The general appearance of the country in Persia* is characterised by its chains of rocky mountains, its long arid riverless valleys, and its still more extensive salt or sandy deserts. The northern provinces form an extensive table land, which rises from a lower plain, and is interspersed with numerous clusters of hills, chains of rocky mountains, and barren deserts. The lower ground, under the name of Dushtistan, or the level country, exhibits a succession of sandy wastes, where the eye is occasionally relieved by a dark plantation of date trees, and a few patches of corn, in such places as are blessed with a freshwater rivulet or a copious well. On the banks of the Tigris this tract becomes more fertile. Wherever water abounds, vegetation is most luxuriant; but the country generally suffers from excessive drought. The mountains present masses of grey rock, and the only trees that are found in abundance are the tall poplar and stately chinar (*Platanus orientalis*), and the fruit trees

INDIA.

8035. — 893. *To give some idea of the present state of agriculture in India*, Mr. W. Carey, one of the missionaries, states, in the *Transactions of the Agricultural and Horticultural Society of India*, vol. ii. part 1., 1832, that, in many parts of the country, the same crop is invariably raised on the same ground year after year; hay is never cut till the grass has died or withered on the ground; scientific rotation of crops is a subject to which Indian cultivators are strangers; and the manure produced by animals is generally consumed for fuel. No attempt to improve stock appears ever to have been made in India; though there is every reason to believe that all the animals used in the husbandry of Europe are capable of as high a degree of improvement in India as they are in more temperate regions. The quantity of waste lands in India is said to be so large as almost to exceed belief. Extensive tracts on the banks of numerous rivers are annually overflowed, so that they produce little except long and coarse grass, seldom turned to any useful account. During the rainy season, these tracts are the haunts of wild buffaloes, which in the night come up from them and devour the crops of rice on the high lands. In the cold season, wild hogs, tigers, and other noxious animals, unite with the buffaloes in occupying these extensive tracts of alluvial soil; which, though now so pernicious, might, by embanking and draining, become the richest lands in the country, and contribute greatly to the improvement of the climate. Similar observations might be made respecting immense tracts now wholly covered with wood, and producing nothing whatever to civilise man, but, on the contrary, proving a nuisance to the surrounding districts by affording a shelter to noxious animals. The oppression of landowners, and petty officers, on the cultivator is so great, that in some parts of the country no farmer can reasonably promise himself security for a single night. "Thus," concludes Mr. Carey, "one of the finest countries in the world, comprising almost every variety of climate and situation, diversified by hills and valleys, intersected in every part by streams (most of which are navigable six months in the year, and some of them through the whole year afford every facility for carrying manure to the land, and every part of the produce to market), is, as far as respects its agricultural interests, in a state the most abject and degraded." (p. 10.) This is a most forbidding picture; but it is incident to all countries in a particular stage of their progress in civilisation. Time was when the low districts of England were ravaged by the wolves and bears from the mountain forests, and when the crops on the alluvial vales of her rivers were annually swept away, or at least greatly injured, by floods. As to oppression by superiors, and thieving from others, there will always be abundance of such evils, till mankind are brought to something like equalisation in point of knowledge, and consequently power; till, in short, the mass of society become fit for self-government. (*Trans. Agr. Soc. of India.*)

AUSTRALIA.

8036. — 1037. *The whole territory of New South Wales*, Dr. Lang, writing in 1834, informs us, "is divided, like that of Great Britain, into counties and parishes; but these divisions are scarcely ever referred to in the common intercourse of colonial life. Except in government deeds or legal docu-

ments, the grand natural divisions of the country are the only ones recognised by the colonists." These divisions are the districts of the Hawkesbury, of Hunter's River, of Bathurst, of Illawarra, and of Argyle. The district of the Hawkesbury, which is let out in small farms of from 30 to 100 acres each, has been long considered the granary of the colony, from the extreme fertility of its soil though the system of agriculture practised in it is as slovenly as can be well imagined. The surface of the ground is "for the most part merely scratched; and nothing like a proper rotation of crops is ever dreamt of. Wheat, year after year, for twenty years together, and sometimes wheat and maize in succession off the same ground during the same year, is the Sangrado system of husbandry that prevails on the Hawkesbury." The district of the Hunter's River is let out in farms of from 500 to 2000 acres each. "Dairies are frequent throughout this extensive district; and large quantities of butter and cheese, of superior quality, are forwarded regularly by the steam-boats to Sydney." The vast plains of the Bathurst are chiefly tenanted by black cattle and sheep, and the farms are generally 2000 acres each. This may be considered the wool district. The cultivated land of the Argyle district is almost all in pasture, but there are interspersed extensive tracts of the most barren country imaginable. The district of the Illawarra consists of a narrow strip of arable land of the first quality, let out to "small settlers, who cultivate grain, potatoes, pumpkins, &c., for the Sydney market, their produce being conveyed to the capital by water in small coasting vessels." This is also the timber district, great numbers of the red and white cedar trees growing here, and that wood being generally used for cabinet and joinery work all over the colony. Besides these there are several large tracts of pastoral and alluvial land, which cannot be properly classed in any of the above-named districts; and a very great extent of country remains unexplored. The rich alluvial land on the banks of rivers is called interval land. It is very productive, but is difficult to clear. Norfolk Island, has a soil of the richest vegetable mould, even to the tops of the highest hills, and appears well adapted for the culture of coffee, if not sugar. It is now (1834) occupied as a penal settlement for the colony of New South Wales. (*Dr. Lang's Historical and Statistical Account of New South Wales*, vol. i.)

8037. *General aspect of the country.* The principal town, Sydney, is beautifully situated on Sydney Cove, one of the romantic inlets of Port Jackson, about seven miles from the entrance of that harbour, the headlands at the mouth of which constitute one of the grandest and most interesting features in the natural scenery of the country. Many of the most interesting localities on the shores of Port Jackson, between Sydney and the headlands, are in the hands of private proprietors. On Woolloomooloo Hill (*fig. 1153.*), which is an elevated projection of the land, about a mile from Sydney, most of the officers of the colony have houses. The second town of the colony is at present Paramatta; but Maitland will, probably, soon supersede it, as the latter place is situated at the head of Hunter's River, in the centre of the most extensive agricultural and grazing district in the colony. Between Sydney and Maitland there are two steam-boats, and a company has lately been formed, called "The Hunter River Steam Navigation Company." With the exception of the large open plains in the interior of the country, the territory of New



South Wales is, in its natural state, one vast forest. On the banks of the rivers, and especially on the alluvial land within the reach of their inundations, this forest becomes what the colonists call a thick brush or jungle. Immense trees of the genus *Eucalyptus*, such as the stringy bark (*fig. 1154.*), the Blue gum, *E. piperita* (*fig. 1155.*), and the Iron bark, *E. resinifera* (*fig. 1156.*), tower upwards in every direction, to the height of 150 or 200 feet; while the cedar, and other trees of inferior elevation, with innumerable wild vines and other parasitical plants, fill up the interstices. In the sterile region, the trees are stunted in their growth, and of a most forbidding aspect; their trunks and naked branches being frequently blackened by the action of fire, as in the *Eucalyptus* (*fig. 1157.*). The soil of these regions is a white sand, and nothing can exceed the loneliness and desolation of the scene. (*Ibid.*)



1154

STRINGY BARK, 60 FT.

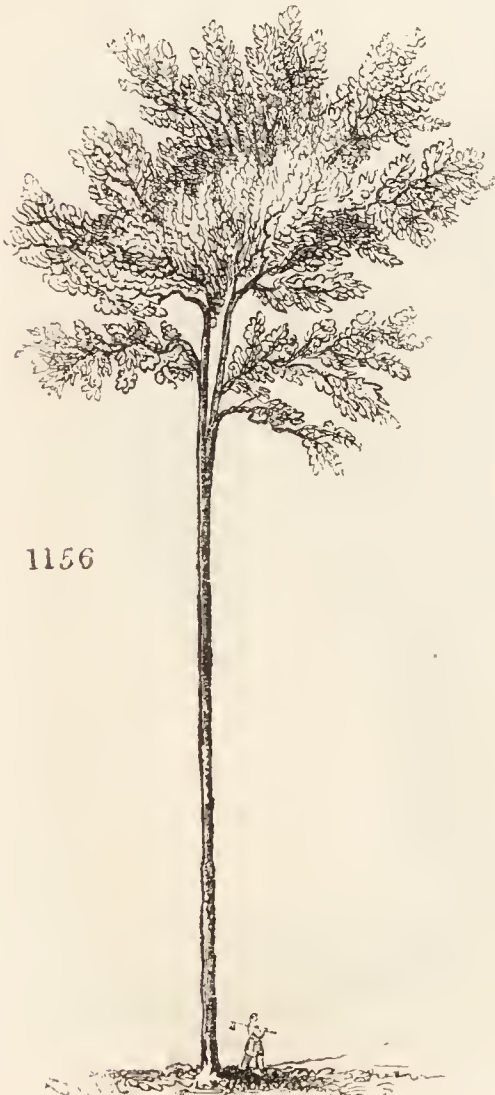


1155

BLUE GUM, 50 FT.

8038. *The settled portion of New South Wales*, in 1833, Sturt tells us, extended from the 36th to the 32d parallel of latitude. The population of the colony is said to consist of 45,000 free settlers, and 25,000 convicts. Its imports, in the year ending January, 1833, amounted to 602,032*l.*, of which 144,793*l.* was the value of commodities imported from foreign states, the rest being the produce of Great Britain and her colonies. The exports amounted to 384,344*l.*, of which 81,969*l.* consisted of British and foreign merchandise re-exported, and the remainder was the produce of the colony, the New Zealand fisheries, and the South Sea Islands. The chief articles of export, which were shipped to the mother country, were:—New Zealand flax, 806 tons, value 15,393*l.*; sperm and black oil, 3186 tons, value 142,921*l.*; and wool, 1,515,159 lbs., value 73,559*l.* In 1831, no less than 150 vessels entered the harbour of Port Jackson from foreign ports, the amount of their tonnage being 31,259 tons. (*Sturt's Expedition into the Interior of Australia.*)

8039.—1038. *The mineral productions.* Marble of a good quality, and which takes a beautiful polish, has been obtained in Argyle. In one part of its course, Hunter's River flows for a considerable distance over



1156

IRON BARK, 200 FT.



1157

OLD GUM, 70 FT.

rocks of jasper; and beautiful agates, opal, and chalcedony, besides innumerable petrifications, are found on its banks. (*Hist. and Statist. Account, &c.*)

8040. — 1040. *Natural productions of New Holland.* A peculiar character is given to the woods of the extratropical parts of New Holland, and to the woods of Van Diemen's Land, by the species of trees of the order *Proteaceæ*. These are numerous, and the leaves of the generality of them have a vertical



HONEYSUCKLE.

position, and a similar aspect on both surfaces. These surfaces, a close inspection teaches, are distributed, by a reticulation of the fine veins of the leaf, into numerous small compartments or areolations, within each of which, on one face of the leaf, and very generally on both faces, is lodged a minute gland. (See *Brown's Supp. prim. Flor. New Holl.*)

8041. *The vegetable productions of New Holland.* Some of the most common trees in the neighbourhood of Sydney are several of the different kinds of *Eucalyptus* (*fig. 1154. to 1157.*); what is there generally called the honey-suckle (*Banksia integrifolia*) (*fig. 1158.*), the apple tree (*Angophora lanceolata*) (*fig. 1159.*), the forest oak (*Casuarina to-*



APPLE TREE, 60 FT.

rudis) (*fig. 1160.*), and the grass tree (*Xanthorrhæa arborescens*) (*fig. 1161.*). The last is particularly beautiful. There are also the broom (*Jacksonia scoparia*) (*fig. 1162.*), which is called the dogwood at Port Jackson, and the wood of which is very difficult to burn, and the tea tree (*Melaleuca*



FOREST OAK, 30 FT.



GRASS TREE.

linariæfolia) (fig. 1163.). The name of tea tree is given almost indiscriminately to several kinds of Melaleuca, and Leptospermum, because it is supposed that the first colonists made tea from the leaves of some of the species of these genera. The terms blue, red, or white gum trees, as applied to different species of the genus Eucalyptus, refer to the colour of the bark. The wood of trees of this genus is very durable; as a proof of which, Dr. Lang informs us that a stump of a species of Eucalyptus (blue gum tree) remained quite sound for thirty-five years in the ground, after having been cut down. When it was

1162



BROOM, OR DOGWOOD, 12 FT.

1163



TEA TREE, 20 TO 30 FT.

necessary to remove it, it took a fortnight to burn out the root. The circumstance of this trunk remaining quite sound for such a great length of time is very remarkable; and reminds us of what Dutrochet states respecting the stump and roots of the silver fir (*Gard. Mag.*, vol. x. p. 408.); viz., that they will continue to live, and even grow, during a great number of years after the tree has been felled. (*Lang's Hist. and Statist. Account.*) All these cuts of Australian trees; and also the view (fig. 1153.) are from drawings kindly sent to us by our friend, John Thompson, Esq. of Sydney, a gentleman whose taste in landscape is not unknown to the readers of the *Gardener's Magazine*.

8042. — 1041. *Agriculture in Australia* appears to be making considerable advances, from the more frequent influx than formerly of emigrants with capital. Some Scotch farmers have settled in the interior of New Holland; a good many have located themselves in Van Diemen's Land, and there are some even on the Swan River. In 1830, the Cashmere goat was imported into the colony by Mr. Riley, and about the same time a German gardener, that Mr. Riley took with him from England, established vineyards in different parts of the country, which, from accounts received in 1834, have already produced wine. (*Sec Gard. Mag.*, vol. x. p. 159.)

8043. *The principal agricultural products of New South Wales* are wheat and maize. The cost of clearing heavily timbered alluvial land is about 5*l.* an acre, but sometimes a single crop of maize clears the expense. The return of wheat varies from 15 to 40 bushels an acre, and in the Argyle district it has reached 45 bushels; but the system of husbandry is, generally speaking, wretched in the extreme. The staple article of Australian produce is wool, of which Dr. Lang says, 1,515,156 lbs., and Sturt, 2,500,000 lbs., were exported in 1833. It is generally supposed that John Macarthur, Esq. was the first to introduce fine-woolled sheep into the territory; and, though the honour is also claimed by another individual, there is no doubt that Mr. Macarthur had the merit of having demonstrated their adaptation to the climate, and the capability of the colony to produce wool to almost any extent. This has been effected in comparatively a very short space of time. About 1792, Mr. Macarthur commenced sheep-farming, and in a year or two, he had an opportunity of crossing his coarse-fleeced sheep with merino blood. So prolific was the mixed breed, that in ten years, a flock, originally consisting of not more than seventy Bengal sheep, had increased to 4000. In 1803, Mr. Macarthur went to England, carrying samples of his wool, which was so much approved of by a committee of manufacturers, that government were induced to encourage him in his attempts to produce fine wool in the colony, by directing that he should receive a grant of land for that purpose, in the low pastures, which is now named the district of Cambden. In 1806, Mr. Macarthur returned to New South Wales with two ewes and three rams, purchased by him from the merino flock of George III.; his flock was removed to the low pastures, and since that period, the wool of New South Wales has been rapidly increasing in value in the home market. (*Dr. Lang's Hist. and Statist. Account*, and *Sturt's Exped. into the Interior of Australia.*)

8044. *Fruits and other vegetable products cultivated in the colony of New South Wales.* Vines, which are the most important of the fruit-bearing plants to a young settlement, have only been cultivated a few years to any extent. "There are now, however, many acres of vineyard throughout the country;" and wine and brandy have been manufactured from grapes grown by Mr. Macarthur's sons at Cambden. The wine is very similar to the light wines of France and Germany. Tobacco has been grown to great extent, particularly on the rich alluvial lands, and is only inferior in point of manufacture. Olives, hops, indigo, and opium, are beginning to be cultivated: the castor-oil tree (*Ricinus communis*) grows luxuriantly, and oranges and all the genus *Citrus*, and figs and peaches, bear abundantly. The hedges to the fields are generally formed of quince or lemon trees. There are several orange orchards, producing annually from 12,000 to 20,000 dozen each. The fruit of the loquat (*Eriolobrya japonica*) is sold in great quantities in the Sydney market. Cotton, coffee, tea, and sugar have been tried, and found to answer, though their cultivation has not yet been attempted on a larger scale. (*Hist. and Statist. Account*, vol. i. p. 375.)

8045.—1042. *As a country for emigrants.* During Sir Thomas Brisbane's administration, any respectable person, who pledged himself to government to maintain and employ ten or twenty convict servants, could obtain 100 acres for each such servant. This occasioned a great demand for convict labourers; and, instead of government being obliged to establish penal settlements in order to employ them, there was, during the government of General Darling, "applications for no fewer than 2000 convicts lying unsatisfied at the office of the principal superintendent of convicts." There is no doubt that New South Wales is an excellent country for the agriculturist; but it is subject to some drawbacks. A season of drought, which continued three years, began in 1827, and it appeared from the statements of old natives, that the country was subject to periodical visitations of that nature. It is also subject to inundations, particularly from the Hawkesbury River. From the imperfect state of husbandry throughout the country and the fertility of the soil, much may, however, be done by an experienced agriculturist. For eight months in the year, from March to November, the climate is delightful; but during the Australian summer, the heat is considerable. The most unpleasant part of the year is during the prevalence of the hot winds. "These winds occur on an average four times every summer, and continue from twenty-four to thirty-six hours at a time;" the atmosphere feeling like a current of heated air from a furnace, and the thermometer generally standing at from 90° to 100°, and sometimes even reaching 112° of Fahrenheit. The extreme dryness of the air, however, prevents this degree of heat from being so intolerable as it would be in a moist climate like England. The hot wind is generally succeeded by a violent gust from the southward, and very often by a shower of hail. (Vol. ii. p. 186.) Very few persons live to attain old age; but they generally enjoy excellent health and spirits while they do live. In short, observes Dr. Lang, "the lamp of life in the salubrious climate of New South Wales is like a taper immersed in a vessel filled with oxygen gas; it burns more brightly than in the common air, but it is sooner extinguished." To persons possessing property to the amount of from 2000*l.* to 5000*l.*, "New South Wales presents a most eligible prospect for effecting a comfortable settlement. They may put out part of their capital at interest for ten per cent. on excellent security, and 1000*l.* will not only purchase 1000 acres of land at 5*s.* an acre (the selling price in 1833), but will be amply sufficient to stock it." (*Lang's Hist. and Statist. Account*, vol. ii. p. 200.)

8046.—1044. *Van Diemen's Land.* This colony may be considered as the most prosperous in Australia, and the suitableness of its climate for Englishmen is every year more and more confirmed. "The colony," Mrs. Prinsep observes (*Journal of a Voyage from Calcutta to Van Diemen's Land*), "contains every source of wealth and health, in short, every thing but money. Interest on mortgages, with the very best securities, is 15 or 20 per cent. Bank shares pay 16 per cent. There is no immediate prospect of any check to that rise in the value of land which is now observable. Money well invested in land here, and allowed to accumulate, will be tenfold its original value in fifteen years. 200*l.* would purchase a noble property here. 1000*l.* will buy a fine, healthy, and beautiful estate of 1200 acres, 200 of them already in cultivation, and the whole becoming more valuable every year. Corn and potatoes are exported to Sydney; and wool to England. Wool averages 6*d.* per pound. The whole colony is on the advance, and its resources remain to be developed. Fresh lands are granted in square miles, in the proportion of the square mile, or 640 acres, for every 500*l.* sterling of capital; which is the largest grant that is made to any settler without purchase, as the smallest is 320 acres. The total territory in acres is 15,000,000, or which about one half is rocky, or thickly wooded; the rest arable and pasture: the proportion of arable being as one to six of pasture. The total number of acres granted to individuals, up to December, 1829, is 1,323,523; consequently, there are 13,676,447 unlocated acres."

8047. *The wool of Van Diemen's Land* is of peculiar softness, and, from the greater attention now paid to cleaning and packing, the price is rising. Wheat is of a very superior quality, weighing generally about sixty, and sometimes as much as sixty-five pounds per bushel. Oats are beginning to be raised; barley has not yet succeeded; peas, and other species of pulse, are plentiful. Skins are also valuable; seal-skins the most so, being worth about 2*s.* each in England. Kangaroo skins are essentially useful in the colony for hats, and also for shoes, which are remarkably durable: when well packed, and of a good size, these skins fetch nearly 6*d.* a pound in London. Shoemakers make 100 per cent. on the raw material. (*Cape of Good Hope Lit. Gaz.*, vol. iii. p. 187.)

EGYPT.

8048.—1077. *Egypt, under the government of the present pasha*, is undergoing extensive political improvements, among which agriculture, Mr. St. John observes, is not altogether forgotten. The culture of cotton has been commenced on a large scale by government; and an extensive tract of country round Cairo, which was long rendered useless by prodigious mounds of rubbish, many of them exceeding seventy feet in height, has been cleared, the mounds having been levelled, and planted with olive trees, which bore fruit the second year. The teak tree has been introduced from India, and is found to thrive near Cairo as well as in its native country. The mango, the pine-apple, and other tropical fruits, have been tried; and there is an English garden of naturalisation, under the direction of Mr. Trail, an English botanist. On the whole, there can be no doubt, that, if the present comparatively liberal policy of the Egyptian government be continued for another generation, the face of the country, and the condition of its inhabitants, will be entirely changed. Nature has supplied an excellent soil, and abundance of water, under a climate sufficiently hot to produce the produce of tropical countries, and yet not so much so as to prevent the grains of temperate regions from being profitably cultivated. (*Egypt and Mohammed Ali*, p. 443.)

MOROCCO.

8049.—1098. *Agriculture in Morocco.* The farmers plough and sow at the same time. The ploughing is performed by one man, who, while he guides the plough, which has a single handle, with his right hand, holds the reins, which are made of the palmetto twisted, and a long, thin, pointed stick to goad the oxen, in his left. When he sows, he leaves the plough, scattering the grain very sparingly with his right hand, and harrows it in by passing the plough again over the surface, the furrows being straight, narrow, and very shallow, without any ridge. The ploughshare has merely a simple tip of iron, which is taken off when the husbandman ceases to work, to prevent its being stolen. (*Brooke's Travels in Spain and Morocco*, vol. i. p. 303.)

CAPE OF GOOD HOPE.

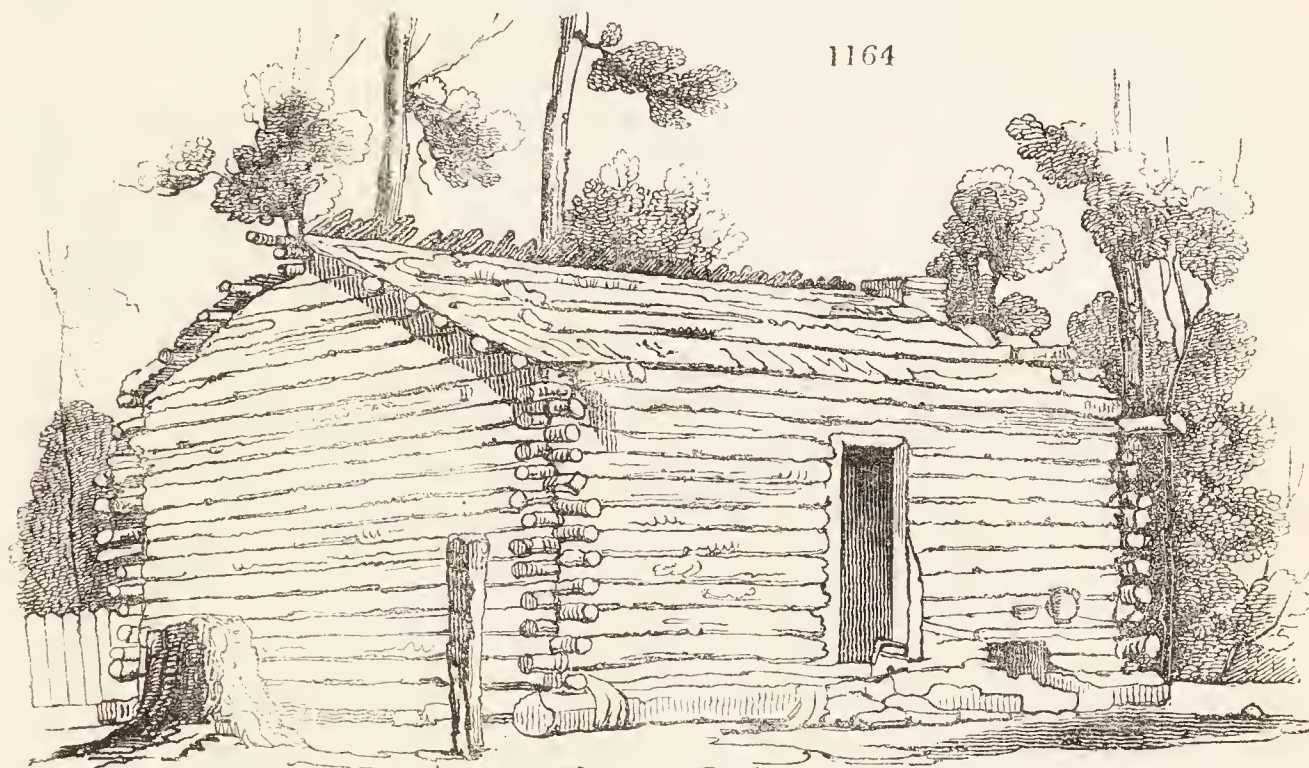
8050.—1133. *Albany.* At the close of 1824, when this new settlement was hastening to dissolution, the commissioners of enquiry removed certain political evils, and the country at once commenced a march of success, which John Centlivre Chase believes "the most unparalleled in the history of colonisation." In August, 1833, the Caffre trade, chiefly in ivory, amounted to about 34,000*l.* annually; and the exports increased from 32,273*l.*, their amount in 1829, to 51,290*l.*, their amount in 1832. Hides, horns, skins, tallow, butter, salted provisions, and ivory, formed the principal items. Cultivation is extended. Oats, barley, and oat-hay are the chief commodities; wheat has also been raised, and Indian corn, fruit, and vegetables grow most luxuriantly. Cattle, sheep, and horses are abundant, and every necessary of life is extremely cheap. There are about 26,000 sheep, the wool of which sells at upwards of 1*s.* per pound. Graham's Town has increased from 22 houses to 600; and eight villages, eleven places of worship, and fifteen schools have been built. Hat, blanket, and tile manufactories, numerous limekilns, three water and six wind mills, two tanneries, and two breweries, have been established. There is an infant school, a savings' bank, a public reading-room, and a commercial hall. A newspaper was commenced in January, 1832, and it is prospering. The population, in 1833, was 9913; and, as a proof that the country is favourable to human life, only 24 out of 248 persons, who landed in 1820, had died in 1830. "Such," says Mr. Chase, "is the result of thirteen years' settlement, nearly five of which were those of

failure and distress. From what has been related, it may be seen, whether success has attended the efforts of the immigrants or not, their only difficulty, in as far as my own knowledge goes, is that of a want of additional labourers to gather in the harvest of growing prosperity; and, as a proof of this want, I refer to the many and frequent appeals to the home government, successively made since 1825, for a new emigration." (*The Cape of Good Hope Lit. Gaz.*, vol. iii. p. 182.)

AMERICA.

8051. — 1153. *Climate of North America.* Over the whole extent of North America, it is universally admitted that the clearing of the country has modified the climate; that this modification becomes every day more manifest; that the winters are now less severe, and the summers less hot; and, in other words, that the extremes of temperature observed in January and July annually approach each other. (*Jones's Jour.* Ap. 1834.)

8052. — 1159. *The soil of the United States* is adapted to almost every species of culture. Wheat grows everywhere; and tobacco, hemp, and flax between the Potomac and Roanoke and Mexican Gulf. All the grains flourish in the valley of the Mississippi; but it is particularly in the delta of that river (which, like that of the Nile, is the work of the waters) that the sugar-cane and indigo succeed best. Almost everywhere, the earth abounds in pasturage, but is not adapted to the growth of fruit trees, or only produces fruit tart and without flavour. The most productive kinds of culture are those of colonial articles and vegetables; a species of cultivation for which the Americans are indebted to the French of St. Domingo, who have taken refuge among them. They are also indebted to them for some seed and kernel fruits. The territories of the United States, with regard to agriculture, may be divided into two parts, perfectly distinct from each other. The lands bordering on the Atlantic are generally bad or middling; but those on the other side of the Alleghanies, in the basins of the St. Lawrence and the Mississippi, are not exceeded by the best lands in Europe; and have, besides, the advantage of being nearly all virgin, and easily cultivated. Vegetation is hardy, but prompt, which is occasioned by the humidity of the soil. (*Beaujour's Sketch of the United States*, p. 81.)



8053. — 1192. *Climate of the Canadas.* John Young asserts, "that, 2000 years since, the climate of Europe was precisely similar to that of British America at the present day; in support of which he quotes many authors of antiquity. He attributes the change, first, to the extirpation of the forests and the draining of the morasses; secondly, to the increase of population, and consequent evolution of animal heat, and the warmth communicated to the atmosphere by the fires within the houses; thirdly, to the extension of tillage, the process of putrefaction alone generating considerable heat." (*Brit. Farm. Mag.*, vol. vi. p. 196.) Fig. 1164. is a specimen of the Canadian log houses, which have been well represented in the *Sketches, &c.*, of Captain Hall, from which our cut is taken.

8054. — 1195. *Emigration to British America.* Mr. Ferguson, who visited Canada in 1831, says, "that Upper Canada certainly is blessed with all the solid appearance of human happiness, independence, and comfort." The notes of this gentleman are given at length in the *Quarterly Journal of Agriculture*, vol. iii., and well deserve to be consulted by all emigrants. In a work on *Emigration to British America*, by John M'Gregor, Esq., published in 1831, the British possessions in North America are stated to be the Island of Newfoundland, Cape Breton, and Prince Edward Island; the province of Nova Scotia, New Brunswick, and the Canadas; the region of Labrador and the territory west of Hudson's Bay. Newfoundland bears a striking resemblance to the Western Highlands of Scotland, and is chiefly adapted for the rearing of cattle and sheep. Prince Edward Island possesses an excellent climate and soil, and is, taken altogether, a most desirable spot for emigrants. "The society in the island is good, and the inhabitants consist of Europeans from all nations, but particularly from Scotland. Cape Breton is a small island, peopled by between twenty-five and thirty thousand souls, chiefly from the Western Highlands of Scotland." The climate, though humid, is salubrious; the general aspect of the country romantic and mountainous, and covered with forests; and the valleys contain extensive tracts of excellent soil. Nova Scotia is an extensive country, fitted to receive "thousands, perhaps millions, of emigrants." The winters are severe, but the air at that season is generally dry. This peninsula abounds with extensive fields of coal, with ironstone, with gypsum, and, it is believed, with rock salt. New Brunswick has a climate particularly suited to the constitution of Britons. The country is covered with immense forests of evergreen and deciduous trees, and it is everywhere intersected by rivers fit for navigation. Coal, iron, gypsum, and sandstone abound. The Canadas include an extensive territory, with a climate which is on the whole salubrious. The thermometer, in summer, rises as high as 80° in the shade, and in winter sinks below zero. The winter in Lower Canada is two months shorter than that of Upper Canada. The geology of Canada is little known; the principal rocks appear to be trap and limestone. There are soils of every description, but the largest tracts are either alluvial, or of a lighter character, approaching to sand. Labrador, and the territory west of Hudson's Bay, Mr. M'Gregor does not consider as suitable to emigrants. We can only refer the reader, who is desirous of emigrating, to Mr. M'Gregor's book; or to a very copious abstract of it which will be found in the *Quarterly Journal of Agriculture*, vol. iii. p. 880. to 924.

PART II.

AGRICULTURE CONSIDERED AS A SCIENCE AND AS AN ART.

8055. — 1285. *In the arrangement* of this division of the Encyclopædia of Agriculture, we endeavoured, in the first three books, viz., those on plants, animals, and the soil, to establish the science of agriculture; and in the succeeding two books, on the mechanical agents of agriculture, to describe the tools, instruments, machines, and other engines, and operations performed by them, which constitute the art. In this Supplement the chief additions to the scientific part will be found to be some paragraphs on mildew; some on the new theory of the rotation of crops (according to which plants are supposed to injure the soil by their excretions, instead of exhausting it of specific kinds of nutriment, as was heretofore conjectured); and some on humin, and on the management of manures. The additions to the mechanical part, or the art of agriculture, include a number of new implements or machines, and buildings; among which are, one of the most complete threshing-machines that has ever been erected; a very superior description of farmery; a hop kiln of a new and superior construction; and some excellent designs for labourers' cottages.

8056. — 1294. *A plant*, Dr. Lindley observes, "is to be understood as a mass of individuals, each having its own peculiar system of life, growing together in a definite manner, and having a common organisation, but nevertheless capable of vegetating independently, and not unfrequently separating spontaneously from each other. These individuals are buds, each of which is perfect in itself, and exactly the same as all the others of the same plant. They are combined by means of a fibro-cellular substance called bark, which is to be understood as being composed of the cellular integuments of as many individuals as the plant may have developed buds. As the act of vegetation consists in the development of a germinating body in two opposite directions; the one upwards, as stem, the other downwards, as root; every bud, when it begins to grow, must be subject to this law, provided it is the independent being which it has been represented to be. And, in fact, if a bud is separated from the system to which it belongs, it does follow this law of development, as is well known to gardeners from their practice of propagating plants by buds and eyes. Now, if buds, when in a state of combination, undergo the same kind of development as when isolated, as it is reasonable to suppose they do, it will be found that the fibrous and vascular tissue of the wood and bark, which always descends from the buds, really constitutes their roots: and that, consequently, the concentric circles of the wood and bark of dicotyledonous trees are congeries of roots formed by the annual development of buds upon the surface of the plant." (*Jour. R. Institut.*, May, 1831, p. 479.) To those who are desirous of keeping up their knowledge of the physiology of plants, with the rapid progress making in that department of science, we would strongly recommend, as scientific works, *De Candolle's Physiologie Végétale* and Lindley's *Introduction to Botany*; and as popular works on the same subject, Mrs. Marcet's *Conversations on Vegetable Physiology*, *Main's Illustrations of Vegetable Physiology*, and Lindley's *Lady's Botany*.

8057. — 1515. *Influence of temperature on the germination of seeds*. Seeds in general will not vegetate in a temperature of 9° or 10° above zero. But, from some experiments lately related to the Royal Academy of Sciences at Paris, it appears that seeds of wheat, barley, rye, and beans, have been submitted for fifteen minutes to the temperature of the congelation of mercury, and yet germinated afterwards. The same seeds which lost their germinating power at 122° in water, preserved it to 143° in vapour, and 173° in dry air. The limit of germination varies with the duration of immersion. Thus, not more than one fifth of the seeds of wheat, barley, and rye would germinate after being kept for three days in water at 95°; the same seeds will germinate in sand slightly moistened at 113°. The germinative principle of cerealia and legumes is destroyed at 173° in fifteen minutes. In most seeds 122° will destroy the vital principle. In hot countries where the temperature of the soil is as high as 118°, and even 122°, the cerealia disappear; first the barley, then the wheat, and finally the rye. (*L'Institut.—The Printing Machine*, vol. i. p. 107.)

8058. — 1526. *Nitrogen gas*. Cruciferous plants exceed all others in the quantity of azote (nitrogen) which they contain; and, on account of this quantity of azote, ammoniacal principles are frequently obvious in their fermentation or putrefaction. To the same cause are, perhaps, to be attributed these two phenomena; first, that the cruciferæ yield more of nutritive matter than most other esculent vegetables; and, secondly, that they require, to produce them in perfection, a soil well imbued with animal matter, or a station contiguous to the residence of man. (*Dec. Syst.*, vol. ii. p. 142.)

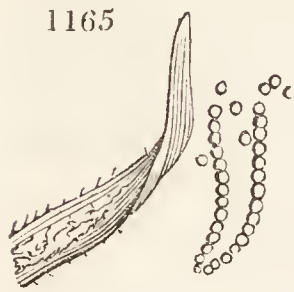
8059. *Presence of azote in seeds*. M. Guy-Lussac remarks, "that some seeds contain azote is a well-known fact, since a substance of an animal nature may be extracted from them, as gluten from wheat flour; but he observes that he has nowhere seen it stated that all seeds contain animalised matter. To be satisfied that this is the case, however, it is requisite only to submit any seed to distillation, either in its natural state, or, what is better, deprived of its ligneous envelope. Nevertheless, ammoniacal products are not always immediately obtained by distillation. Rice, for example, gives a very acid product; but the presence of ammonia is easily proved by the addition of lime. Kidneybeans and many other similar seeds give a very ammoniacal product. In general, any grain, deprived of its envelope, may be considered as composed of two parts; one vegetable, which gives an acid product by distillation; and the other animal, yielding ammonia; so that the acid or alkaline character depends upon the predominance of one or other of these matters. M. Guy-Lussac submitted all grains which came in his way to distillation, and all of them gave ammonia, the greater number immediately, and the others after the addition of lime; and he considers that this circumstance will explain the nutritive quality of grain, and the astonishing fertilising property of seeds as manure, after the oil has been extracted from them." (*An. de Chim. et de Phys.*, May, 1833; and *Phil. Mag.* for May, 1834.)

8060. — 1534, 1535. *Fertility of soils*. The theory promulgated in these two paragraphs is, to a certain extent, at variance with the new doctrine of soils becoming poisonous by the deposition of excrement, which will be found given at length, in the section on the rotation of crops, § 2217. in the *Encyclopædia*, and § 8069. in this Supplement.

8061. — 1694. and 1708. *Blight and mildew*. The term blight is indiscriminately employed by empirical cultivators, and by the unscientific public generally, to plants injured either by fungi, or by insects, and sometimes even to diseased plants. If it is to be used at all, it would be more correct to use it adjectively in connection with the cause of the injury; as, for example, blighted by insects, by fungi, or by disease.

8062. *Mildew*, one of the greatest enemies that the agriculturist has to contend with, is nothing more than several species of parasitical fungi, which attack different kinds of plants, varying in their nature and appearance, according to the plants attacked; or, in technical language, being specifically different on different plants. The fungi, commonly called mildew, are divided into three classes: 1. Those which grow, or rather lie, on the surface of leaves, and which, perhaps, do not derive nutriment from the plant; 2. Those which are formed in the interior of the stem or leaf, and protrude themselves from it when ripe; and, 3. Those which only attack the roots. All are extremely simple in their organisation, and very minute in their forms; they seldom appear in the open air, but in autumn.

8063. *The first class, or mildew composed of those fungi that live on the surface of leaves, injure a plant by preventing its respiration, but do not appear to draw any nourishment from it.* One of the most common of these fungi is that called *Sporótrichum*, from *sporo*, a sporule, and *thrix*, hair, in allusion to the filamentous nature of its sporules. This is a very destructive parasite, and it is found upon a great variety of plants. The leaves and even fruit of peach trees are often attacked by it, and it is frequently mistaken by gardeners for an insect. Another very destructive superficial fungus is called *Acrospórium monilióides* (fig. 1165.), and it consists of a number of globules, attached to each other, which, when magnified, appear like the beads of a necklace, and in many cases are found standing upright. When ripe, these globules fall; and, taking root, form fresh strings, or necklaces, like the first. Sometimes little tufts of these globules appear fixed to stalks; and, from some fancied resemblance to the brushes used for sprinkling holy water, are called *Aspergillus*. (fig. 1165.) The superficial mildew which infects the onion, and is very fatal to that plant, is called *Bótrytis*. Its name signifies a bunch of grapes; and it is thus called from a fancied resemblance between that fruit and its clusters of little globular seeds and seed-vessels. All these and many other superficial mildews are known by gardeners by the popular name of blight, and their devastations are frequently mistaken for those of insects.



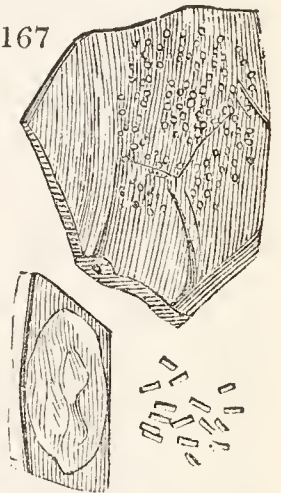
1165

8064. *The second class of fungi, viz., those which spring from the interior of leaves and stems, are by far the most fatal.* These fungi generally appear in a sort of bag or case,

which is supposed to be formed of the cuticle of the affected leaf; and they may be called hypodermous fungi, or internal mildew. One of the most common of these, is that which attacks the common cabbage (fig. 1167.), *Cylindrospórium concéntricum* *Grev.* These very destructive fungi have the appearance of small white patches, or specks, of frosty incrustation, which, when magnified, are found to consist of a number of small cylinders, lying end to end, or across each other. These cylinders are all filled with seed, and burst when it is ripe, scattering it in every direc-



1166



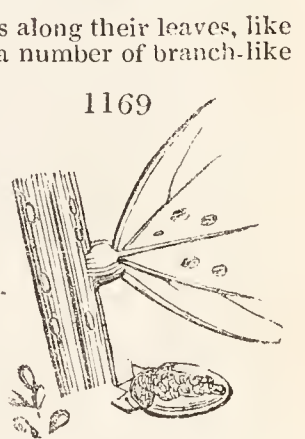
1167

tion: wherever it falls upon the leaf it takes root, and thus the fungus spreads rapidly. The mildew which attacks rose trees and many other flowering shrubs is a kind of *Urèdo*. This name, derived from *uro*, Lat., to burn or scorch, is applied to those occasional discolorations of the surfaces of plants which were formerly attributed to blights, or injuries from the atmosphere, and which have the appearance of a brown powder. *Urèdo effusa* *Grev.* (fig. 1168.) generally shows itself on the under sides of the leaves of the *Rosàcæ*, and spreads rapidly.

Urèdo Ròsæ *Pers.* is another kind, which also attacks rose trees. The bean and pea are affected by a kind of mildew (*Urèdo Fàbæ* *Pers.*, fig. 1169.), which spreads along their leaves, like



1168

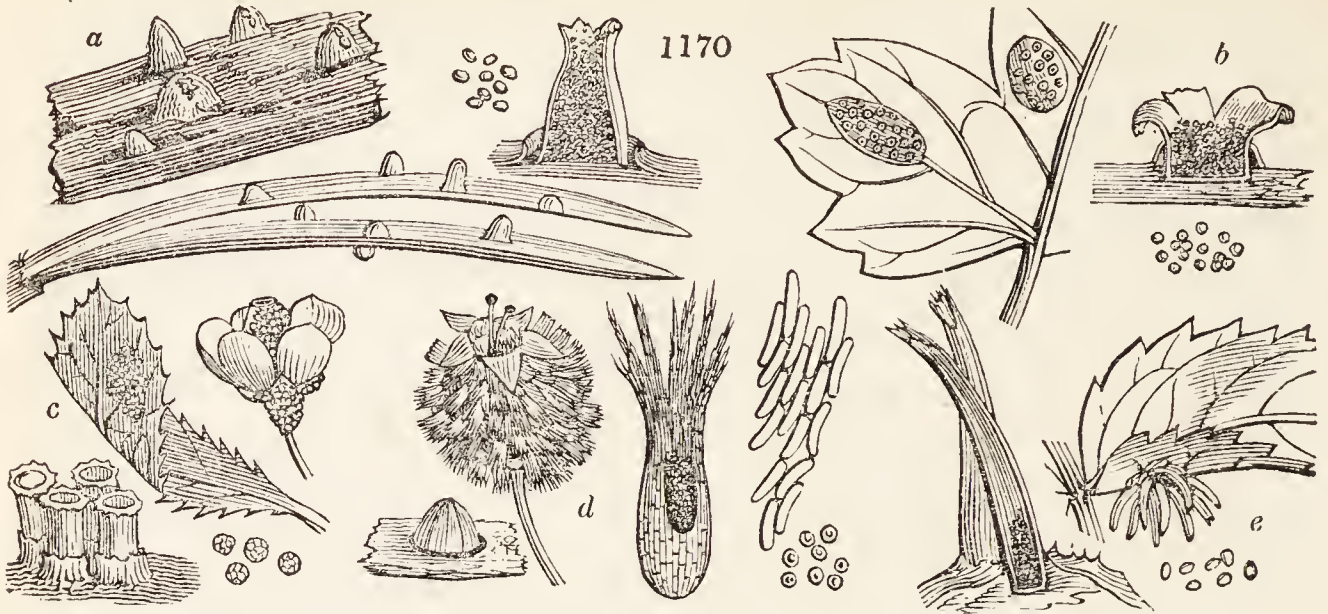


1169

white roots curiously interlaced. From these roots spring a number of branch-like shoots, each bearing a ball-like head or brown berry, which, when ripe, bursts and discharges seed. An internal mildew, which infects corn, is highly injurious to the farmer. It is vulgarly called the pepper brand; and, when corn is attacked by it, it gradually consumes the substance of the grain, leaving in its stead only a dark powder, which has a very offensive smell. This fungus is found only on barley, and in this respect differs from the *Urèdo Ségetum*, or smut, which is destructive not only of barley, but also of wheat and oats. The *Urèdo Ségetum*, or smut, has been the subject of many interesting experiments by Mr. Bauer of Kew, whose discoveries will no doubt throw very considerable light upon the subject. It not only destroys the grain, which it converts into a kind of jelly, but it attacks the leaves and stems, always forming in the interior of the plant, and bursting forth when ripe. Corn is also attacked by a species of *Puccinia*; a very fatal kind of fungus, which always appears divided into cells. *Puccinia Gráminis* (fig. 1172.), which attacks corn, forms in the interior of the stalk; and, when ripe, bursts forth in clusters, like bunches of grapes, of a dark brown colour. *Puccinia Ròsæ* *Grev.* (fig. 1173.) appears on the leaves of rose trees in little brown tufts, which, when opened and magnified, are found divided into extremely minute cells. The ergot on the rye (*Spermœ'dia clavus*

Fries) is a well known and very destructive species of internal mildew. It partakes of the nature of the truffle, and grows out of a spike of corn like a prolonged kernel. It is long, horny, and cartilaginous; and it consists of fibres closely interlaid. This disease evidently originates in the centre of the stem. It affects maize, various species of corn, and grass, and is often found in plants of yellow gentian, &c. Hawthorn trees are attacked by a species of *Æcidium*, which at first appears merely a point made by an insect, but afterwards looks like fungi (*Æcidium laceratum* *Dec.*, fig. 1170. *d*). The sycamore fungus is a black spot consisting of oblong purplish bodies, yellow inside, and containing tubes filled with seeds. *Æcidium Grossulàriæ* *Dec.* (fig. 1170. *b*) attacks gooseberry bushes, and *Æcidium cornutum* (fig. 1170. *e*), the mountain ash: both spread rapidly, and are very difficult to cure. The oak is attacked by a species of *Æcidium*, different varieties of which are found on many kinds of forest trees. The *Æcidium Pini* (fig. 1170. *a*), found on pine trees, has, when magnified, the appearance of a number of nincpins. When ripe, the cuticle which covers the fungus bursts, and emits a powder of a bright orange colour, which is the seed. It is a vulgar error to suppose that a berberry tree (*Berberis vulgàris* *L.*), if planted in a cornfield, will, if infected with mildew, communicate the disease to the corn. This cannot be the case, as the mildew which attacks the berberry (*Æcidium Berberidis* *Pers.*, fig. 1170. *e*) is quite different from any of the fungi which are found on corn. The berberry mildew, when magnified, is found to consist of a number of small orange cups with white films over each. When ripe, these lids burst, and the top of the cup assumes a ragged uneven appearance, like white fungi. Each cup has within it a number of little boxes containing seeds. The mildew on the pear tree is called *Æcidium cancellatum*,

(fig. 1171.) In this figure, *a* is a leaf with the *Æcidium* becoming developed; *b*, a leaf bearing the *Æcidium* fully developed; *c*, portion of a leaf with the *Æcidium* farther developed; *d*, section of a

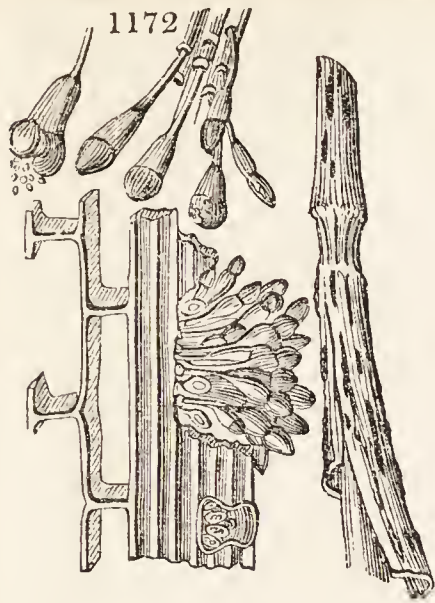


leaf, to show the fleshy thickening that accompanies the development of the *Æcidium*; *e e*, seeds of the *Æcidium*: a seed is called a sporidium; in the plural, sporidia; *f f*, plants of the *Æcidium*: each is

1171

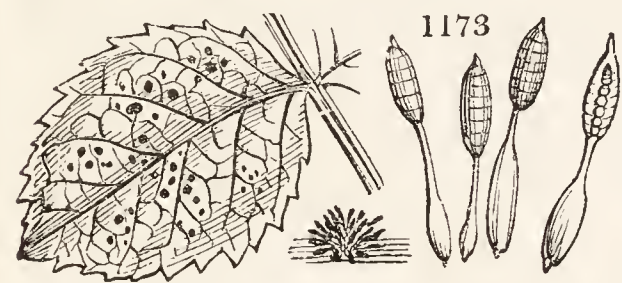


called a peridium; in the plural, peridia. The *Æcidium cancellatum* first appears like mucus, but consists of a number of hairy substances. These hairs, when magnified, appear like a collection of granules of a bulbous shape, each containing a number of balls connected by strings. The balls, though so minute as to be scarcely perceptible by the eye, are yet only receptacles for seed. This is a most destructive fungus: it always seizes on the veins of the leaves, which afterwards turn yellow, and fall off; the branches next wither, and in two or three years a whole orchard is destroyed. Mr. Knight, in 1832, suffered severely from this fungus, and has tried many experiments respecting its cure.

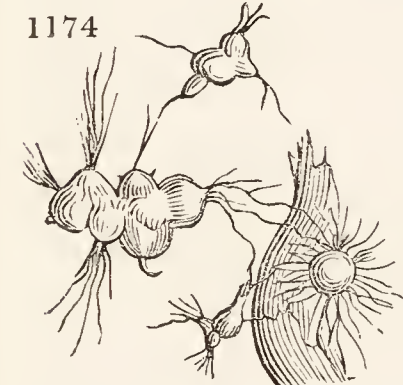


8065. *The principal fungi of the third class, or those which attack the roots of plants, are two; and both closely resemble truffles.* One of these (*Rhizoctonia Crocorum*, fig. 1174.), which is of a brownish yellow, attacks crocuses; and, in those countries where the crocus is cultivated for its saffron as an article of commerce, it makes great ravages. It is called by the French *la mort du safran*, and soon destroys a whole crop. The other fungus (*Periöla tomentösa*) is found on the potato, lucern, &c. It turns the roots, which are naturally white, of a purplish hue. Its ravages are often attributed to grubs. Both these fungi appear to be propagated by spawn, or fibres which spread through the earth, and cling round the roots which they find in their way.

8066. *Remedies for mildew.* All these mildew fungi are very easily propagated, from the rapidity with which they arrive at maturity, and the immense numbers of seeds which they produce. Most of them require only twenty-four hours from the first springing of the plant to the ripening of its seed; and the number produced by each may be guessed from the circumstance of one mushroom being sufficient to propagate 250,000,000. The extreme minuteness of the mildew fungi renders them still more numerous. The first class, or the superficial mildew, appears to be communicated by the air, the seeds when ripe being carried by it from one plant to another, and establishing themselves wherever they touch. They destroy a plant by covering the surface of its leaves, and thus preventing respiration. Plants are generally most affected by superficial fungi after a long drought, when the fibres of their roots are unable to imbibe sufficient moisture from the soil, and the plant thus becomes debilitated, and affords an easy prey to the parasite which attacks it: as a proof, in Scotland, where there are heavy night dews, this fungus is unknown. The



cure for this species of mildew seems evidently to be abundant watering. Some onions attacked in a dry season by *Bötrytis* were nearly cured by abundant watering; and the progress of the disease was effectually checked. The internal mildew requires diametrically opposite treatment. This mildew evidently cannot be communicated by the air, since it always appears to spring from the interior of the plant, and to be at first covered with a thin skin, from which it does not burst till it is ripe. It is impossible, therefore, that this kind of mildew can be communicated externally, and yet the fact that it is contagious is so clear as not to admit a doubt. The only manner in which it appears probable that it can reach the interior is through the roots. The seeds, when ripe, fall upon the earth, which becomes contaminated by them, and they are sucked up by the spongioles of the roots. The correctness of this hypothesis is proved by sowing clean seeds in infected soils; and the young plants from these seeds springing up with the disease upon them. The circumstance of its always attacking the most vigorous plants is thus also explained, as it is evident that, the more rapid the circulation, the greater is the probability of extraneous substances being drawn up with the moisture imbibed by the roots. It is also clear that, in this case, water must



aggravate the disease; as, by exciting the plant to suck it up, it would increase the danger of the seeds of the fungi being drawn in with it. The only cure for this fungus seems to be that adopted by Mr. Knight with his pear trees; viz., taking them up, washing the roots quite clean from every particle of soil, and then replanting them in quite a different part of his grounds. Red plants are said to be more liable to mildew than any other. Red is, indeed, supposed, by some, always to indicate a morbid action, as it shows that the plant is unable to absorb carbonic acid gas from the atmosphere, which is necessary to its perfect health; at all events, it is a proof of disease when leaves, or any other parts of a plant, not naturally red, assume that colour. Other experiments have been made for curing, or at least preventing the spread of, the internal mildew; and Mr. Bauer has found that steeping grains of corn in limewater will produce the desired effect. There appears no cure for mildew in the roots, but by cutting a deep trench round the infected plants, and cutting off all communication between them and the rest of the field. (*Gard. Mag.*, vol. ix. p. 332.)

8067. — 1732. *Elevation*, by occasioning a material difference in atmospheric pressure, has a considerable effect on mountain plants; and, according to Professor Doberainer, is the chief cause of their diminutive size. Experiments have been made to prove this by placing seeds of barley in vessels, containing soil, water, and air, under different degrees of atmospheric pressure; and the result has been, that, where the pressure was greatest, the vigour of the plants was greatest also. (*Ency. of Gard.*, edit. of 1834. § 1746.)

8068. — 1832. *Cross impregnation of the different kinds of corns is an important operation with a view to produce new varieties.* It is thus performed with the gramineous plants: — The first day "that wheat, oats, or barley comes into ear, let the farmer select a few stalks, as breeders; and, with the forefinger of his left hand, pressing gently on the point of the chaffy cover, let him force it open; and, with a pair of small pointed scissors in the right hand, let him cut out the three yellow anthers, not yet opened, and let the chaff spring back to protect the stigma and embryo grain. After four days, let him return to the same stalks with the male flowers, or parts of the flowers, of the variety with which he means to cross, open up the glumes as formerly, and dust the stigma gently with the pollen. One stalk of barley, oats, or wheat, treated in this manner, and the grains carefully sown, may produce several new improved varieties. Peas and beans, too, have their parts of fructification concealed by the papilionaceous corolla, and by similar treatment may produce similar results." (*Quart. Jour. Agr.*, vol. iii. p. 666.)

8069. — 2217. *A new theory of the rotation of crops* has recently been promulgated by M. De Candolle and others. The originator of this theory appears to have been M. Brugmans, who, having placed some living plants in dry sand, saw some small drops of water exude from the extremity of the radicles. It appears that exudations of this kind are, if not always, at least frequently, excretions, or parts of the

juices, which, not having served for nourishment, are rejected by the inferior parts of the vessels of plants. This idea first suggested to M. De Candolle a new theory of the rotation of crops, which has been confirmed to a certain extent by the experiments of M. Macaire. M. De Candolle assumed it as highly probable that the exuded matter from the roots of plants may be considered as their excrement, and that it would be as unreasonable to feed plants on their own excrements, as to feed animals on theirs. The particles which have been deleterious to one genus of a tribe or family of plants, cannot, he thinks, be proved injurious to all the individuals composing that tribe or family; while at the same time he thinks it probable that these excrements might not only be innocuous, but even nourishing, to others. If this opinion be founded on fact, it will easily account for the circumstance of one kind of corn crop being injured by immediately succeeding another.

8070. *M. Macaire*, to subject these theoretic views to the test of experience, has made many experiments to prove that vegetables exude matter from the roots; and these are related by him in a memoir inserted in the *Mémoires de la Société de Physique et d'Histoire Naturelle de Genève*. (See *Edin. New Phil. Jour.*, No. xxviii. p. 215.) After various attempts to raise plants in pure siliceous sand, pounded glass, washed sponge, and on white linen, he decided upon pure rain water. After cleansing and washing the roots thoroughly, he placed them in vials with a certain quantity of pure water. After they had put forth leaves, expanded their flowers, and flourished for some time, he ascertained by the evaporation of the water, and the use of chemical reagents, that the water contained matter which had exuded from the roots. He satisfied himself that this is the fact with respect to nearly all those plants which display their flowers. Several plants of *Chondrilla muralis*, perfectly clean, were placed with their roots in pure water. At the end of a week, the water was yellowish, it emitted an odour like opium, and had a bitter taste. Subacetate and acetate of lead produced a brownish flocculent precipitate, and a solution of gelatine disturbed its transparency. As a proof that this matter was an exudation from the roots, it was found that neither pieces of the root, nor of the stem, when macerated in the water during the same time, occasioned either taste, smell, or precipitate. To prove that plants employ the excretory power of their roots, in order to get rid of hurtful substances which they may have imbibed, the following experiments were made:—Some plants of the *Mercurialis annua* were washed in distilled water, placed so that one portion of their roots dipped into a weak solution of acetate of lead, and another branch of the same root into pure water. Having vegetated in this manner very well for several days, the water was tested by hydrosulphuret of ammonia, which proved, by the black precipitate which it formed, that a notable portion of the lead had been absorbed, and deposited by the branch which dipped into the water. Groundsel, cabbage, and other plants, gave the same results. Some plants grew very well for two days in acetate of lead. They were then withdrawn, their roots well washed with distilled water, which, being afterwards tested, was found to contain no lead, and then placed to vegetate in rain water. In the course of two days this water was found to contain a small quantity of acetate of lead. The same experiments were made with limewater, which, being less injurious to plants, is preferable to lead. The roots being partly placed in limewater and partly in pure water, the plants lived well, and the pure water soon showed the presence of lime by the oxalate of ammonia; and the plants which had grown in lime, and then been transferred with every precaution to pure water, soon disgorged into it a portion of lime. Similar trials were made with a weak solution of marine salt, and with a like result. There can be no doubt, then, that plants have the power of rejecting, by their roots, soluble salts which are injurious to vegetation. Experiments also proved that the roots exuded a greater excess of matter during night than in the day. As it is well known that the light of day causes the roots to absorb their juices, it is natural to suppose that, during the night, absorption ceases, and excretion takes place.

8071. *The inferences which M. Macaire would deduce from his experiments*, are, that the greater number of vegetables exude by their roots substances unfit for their nourishment; that the nature of these substances varies according to the families of plants which produce them; and that some being acid and resinous may be injurious, and others being mild and gummy may assist in the nourishment of other plants. (*Quart. Jour. Agr.*, vol. ii. p. 320.; *Gard. Mag.*, vol. x. p. 12.)

8072. *The reasonableness of this theory of the rotation of crops* seems to be generally allowed by vegetable physiologists; and it is even alleged that it had occurred to the mind of Lord Kaimes, who remarked that plants exhaust or defile the soil chiefly when forming or ripening their seeds. “Culmiferous plants,” this writer observes, “when not allowed to come into flower, draw little nourishment from the soil; but by the time they have begun to ripen their seeds, all their leaves are withered, and they depend entirely upon the soil for a supply of nutriment.” Mr. Towers, an English writer on gardening, seems also to have hit upon something like this theory, when he noticed that two crops of raspberries, in immediate succession, cannot easily be maintained, even with the assistance of abundance of manure. An ingenious writer in the *Quarterly Journal of Agriculture* (vol. iv. p. 880.) is inclined to think that plants exude matter from their roots only when they display their flowers, when they form or ripen their seeds, or when they die. Onions, he says, and all garden vegetables which are not permitted to produce seeds, may be cultivated in the same plot of ground year after year, without the assistance of manure; but not peas, beans, kidneybeans, &c., because they are required to form their seeds. This writer accounts for the raspberry defiling the soil from its wood dying every year after having yielded its fruit. However, there are difficulties in the way of this theory when it comes to be applied to trees and shrubs, and such plants as the saintfoin and lucern, that it will require time to overcome. (See *Gard. Mag.*, vol. x. p. 12.) We are informed, that Professor Daubeny of Oxford is engaged in a series of experiments on this subject; and, from the acknowledged eminence of that philosopher, both as a chemist and as a vegetable physiologist, the result to which he arrives will probably determine the value of the hypothesis, for theory it can hardly with propriety be called, since it has not yet been proved to be generally applicable. Notwithstanding this, however, a writer in the *Quarterly Journal of Agriculture* (vol. v. p. 1.) has endeavoured to explain the advantages derived from fallowing, paring and burning, irrigation, and draining, on the principle of freeing the soil from the excrementitious matters deposited in it by plants; an hypothesis too absurd to need contradiction.

8073. — 2226. *A new theory of the operation of animal and vegetable manures* has lately been promulgated by some German philosophers. According to this doctrine, before putrescent manure can be absorbed by the spongioles of the roots of plants, it must become *humine*, which appears to be carbon in a particular state of decomposition.

8074. *Humine*. Of all the different ingredients of which manures are composed, carbon is supposed to be that which holds the first rank as a food of plants; but it is only in a state for this after it has united with the carbonic acid of the air, and the compound so formed, on being dissolved, is taken up by plants as food. This substance was called *ulmine*, on account of its being first found in the diseased part of an elm; but M. Sprengel gave it the more general term of *humine*, because he found it to exist in soils. Humine is a substance not unlike carbon, for which it has hitherto been mistaken. It is very soluble in spirits of wine, concentrated sulphuric acid, ammonia, and by heat in acetic acid; but it is insoluble in water, and water throws it down in all its solutions. It combines with all the salifiable bases, and forms the *humic acid*: but it has no acid taste; does not redden vegetable blues, &c.; like the gallic acid, it contains only carbon and water, without excess of oxygen. There is a strong analogy between humine and other nutritive substances, such as gum or fecula. It forms a humate with an alkali, which is very soluble in water. All substances which contain carbon are dissolved in the water of vegetation, through the means of humine; and the dissolved mass is taken up by plants as food. Humine in combination with lime, ammonia, or potass, also becomes soluble in soils or dung. (*Quart. Jour. Agr.*, vol. iv. p. 260.)

8075. — 2241. *Noir animalisé*. The charcoal obtained from wood, coal, or peat, by burning in close vessels, after being powdered, is found to act like chloride of lime in absorbing bad smells. In consequence

of this, it has been mixed by the French with those descriptions of manures which give off the most offensive odours, and the manure so formed, which is said to be highly fertilising, is sold under the name of *Noir animalisé*. This discovery was made by M. Salmon in 1831, who has obtained a patent for it, and manufactures it on a large scale. M. Bella, of Grignon, an eminent French agriculturist, tried this manure against the *poudrette* (dried night soil), and found it one fifth part more powerful. (*L'Agronomie*, vol. i. p. 126.) An improvement has been made in this manufacture by M. Damart-Vincent, by which it is sold cheaper than the *poudrette*, or at about five francs for nearly two cwt.. (*Ibid.* p. 251.)

8076. — 2243. *Dutch ashes* are procured by burning bricks made from the mud found at the bottom of ponds, from which peat has been dug. According to an analysis by Professor Brande, they contain, in every 100 parts, siliceous earth, 32 parts; sulphate of lime, 12 parts; sulphate and muriate of soda, 6 parts; carbonate of lime, 40 parts; oxide of iron, 3 parts; and impurities, &c., 7 parts. These ashes are extensively used in Flanders, especially as a top-dressing for clover, at the rate of nineteen bushels per imperial acre. They are also sown on wheat and pastures in March and April; on oats and beans in the beginning of May; on rye in October and November; and in gardens at most seasons. A bushel of these ashes weighs forty pounds; and, as they can be sold in British seaports at 3*l.* per ton, the expense of manuring an acre with them will not exceed 1*l.* (*High. Soc. Trans.*, vol. x. p. 110.)

8077. — 2248. *Bone dust* is usually applied at the rate of two quarters per imperial acre; but by mixing it with finely sifted coal ashes one quarter per acre, it is alleged, may be rendered nearly as effective. When bone dust is used in any quantity above two quarters per acre, it does not produce a corresponding increase in the bulk of crops. The energies of bone dust as a manure is thus explained. The decomposition of the dust in the soil, which is rapid, disengages the phosphoric acid, and the lime and animal carbon is left to be acted on by the air; and these substances being converted into humin readily form a soluble mass, which is taken up by the water of vegetation, and becomes the food of plants.

8078. *Bone manure as compared with stable manure.* By an experiment conducted on a soil somewhat clayey, it appears that, while a Scotch acre manured with sixty bushels of crushed bones produced twenty-four tons of Swedish turnips, an adjoining acre manured with thirty cart-loads of stable manure produced twenty-nine tons. (*Quart. Jour. Agr.*, vol. iv. p. 636.)

8079. — 2270. *Application of recent manure.* The opinion and practices of British farmers have always been at variance with the theory of Sir Humphry Davy on this subject; though it would appear that Sir Humphry believed the farmers to have been converted. "Many," he says, "who have doubted, have been lately convinced; and perhaps there is no subject of investigation, in which there is such a union of theoretical and practical evidence." (*Lect.* VI.) It appears, by two articles lately published in the *Quarterly Journal of Agriculture*, that the Scotch farmers are as much opposed to Sir Humphry's theory as ever. "In theory," it is there stated, "dunghills should be kept dry and cool till they are applied to the land; because, if dung cannot be immediately applied to crops, the destructive fermentation should be prevented very carefully; and, if dung has been fermented till it becomes a mere soft cohesive mass, it has generally lost from one third to one half of its most useful constituent elements. In practice, on the other hand, dunghills are quite exposed to the weather, because all dry litter which has been even decomposed a little, such as that under sheds, in which the cattle are accustomed to lie all night, or an unmixed mass of horse dung, is found to be of itself a worthless application to any crop. These substances should be mixed by turning them over among the wetter cattle dung, so that the whole mass may be fermented to an equable consistency. Practice has also discovered, that the crop of turnips will be risked altogether, if well-fermented dung be not employed. Indeed, many farmers maintain that it cannot be too much fermented for the turnip crop. Two years' fermented dung is kept on purpose, by many who have abundance of straw, to apply to the raising of Swedish turnips; and, certainly, the shorter the dung is, the more quickly will the plants push through the ground, and the more healthy and heavy are the turnips likely to be. Fermented dung is more and more applied every year, even to the potato crop, which was for a long time supposed to do best when immersed among rank dung. In true potato soils, the crop is decidedly better when it is raised with fermented dung. Fermentation is also found useful in killing the vegetative power of the seeds of weeds, or grains of corn, that may have passed away among the straw. 'Thus we see from the evidence' which we have adduced, that there is not only no 'union,' but a decided opposition between the theoretical and practical methods of treating and applying putrescent manures." (Vol. iv. p. 78.)

8080. *There are other objections to the use of recent farmyard manure*, of a less important nature: such as the difficulty of burying it, and, when buried, its liability to be dragged up by the harrows; but principally the tendency which littered dung has to render the land on which it is laid too open, and thus subjecting it to the danger of being burnt up in dry weather. (*Quart. Jour. Agr.*, vol. iv. p. 78.)

8081. *The practical farmer*, in consequence of these reasons, and notwithstanding the experiments made by Sir Humphry Davy, and detailed in § 2238. and § 2239., continues to prefer using manure in a highly fermented state, so as to be what in practice is called short muck. In defence of the practical man, it is contended, that the decomposition of a dunghill does not throw off the most valuable and the most efficient parts of the dung, but chiefly vapour of water. It is allowed by those advocates, that when the texture of the fibrous part of farmyard manure begins to decompose, there will be an evolution of some of the gases which constitute the food of plants: "but what harm," it is asked "occurs to the dung as a manure from the escape of these gases? None whatever. We are told that the gases constitute the food of plants; and that, if they are permitted to be dissipated by decomposition, the quantity of nourishment in the heap of manure will of course be so much diminished; and that, if the bulk of the dunghill be lessened one half, or one third, by excessive fermentation, the quantity of nourishment to the crops will be diminished in a greater ratio." Still it is contended, that, though some of the gases which constitute the food of plants are disengaged from fermenting stable manure, yet that it does not follow that plants will receive them as food directly that they are disengaged. On the contrary, it is considered that they would either reject food in that state; or, if they could not avoid taking it in, that they would be injured by it. "Accordingly, we invariably find that plants suffer from their contact with fermenting dung, and it is this well-known fact, more than any other circumstance, which deters farmers from applying dung in an unprepared state." What has experience determined as the least injurious state in which dung can be applied to any crop? The cultivator answers, in the state of short muck, that is, "a soft cohesive mass," capable of being cut with a spade. What state has the cultivator determined to be the best for putrescent manure to be in when applied to soil not under crop, but which is to be sown or planted some days or weeks afterwards? A determinate answer to this question, founded on experience, has not yet been given. Farmyard manure is sometimes applied to fallows in an unprepared state, but always a considerable time previously to the seed being committed to the soil.

8082. *The propriety of the farmer's practice in applying dung in the state of short muck* is thus given in the work above quoted:—"In 1802, the celebrated Klaproth received from Palermo a substance which exuded spontaneously from the bark of a species of elm, and to which Dr. Thomson gave the temporary name of *ulmin*. It dissolves speedily in a small quantity of water, in which respect it is like a gum: but when the solution is very much concentrated by evaporation, it is not in the least mucilaginous or ropy; nor does it answer as a paste, and in this respect it differs essentially from a gum. When a few drops of nitric or oxymuriatic acid are added to the solution, it becomes a gelatinous mass; which, when slowly evaporated to dryness, and heated with alcohol and again evaporated, leaves a light brown bitter and sharp resinous substance. Thus it appears that ulmin, by the addition of a little oxygen, is converted into a resinous substance. In this new state it is insoluble in water; and that a substance soluble in water should assume the resinous form with such facility, is very remarkable." (*Thomson's Chemistry*, vol. iv. p. 696.) "Berzelius has found this curious substance in all barks; Braconnot, in sawdust, starch, and sugar. But, what is more to our purpose, Sprengel and Polydore Boullay have found it to constitute

a leading principle in all soils and manures. Sprengel appropriately calls it *humic* from its existence in all soils, *ulmin* being given to it by Dr. Thomson as a temporary name." (*Quart. Jour. Agr.*, vol. iv. p. 620.)

8083. *Humic acid and carbonic acid gas*, mixed with water, constitute, according to this discovery, the chief food of plants. Every description of manure is only valuable in proportion as it contains these substances. Humic acid is found in abundance in putrescent manure when it is so far rotted as that it may be cut with a spade. It has been proved that rotted dung contains much more carbonic acid gas and humic gas, weight for weight, than fresh dung. Fresh dung is injurious to vegetation in consequence of its ammonia; which, from its acidity, in practice is said to burn plants. Ammonia becomes concentrated in stale liquid manures, and such manures are, therefore, mixed lightly with water, "in order to dilute the ammonia, and allow the proper action of the humic acid, which exists in large quantity in them." Covering a dunghill with soil in hot weather "is now explained, not as it has hitherto been, viz. by asserting that the earth absorbs and prevents the escape of the carbonic acid gas, which it could no more do than a balloon made of gauze could prevent the escape of hydrogen gas (*Grisenthwaite*); but that a violent fermentation in the dung is checked by the earth partly excluding the atmospheric air and rain water, the oxygen in either of which is indispensable to continue the process of forming carbonic acid gas by uniting with the dung. With regard to composts, it is found that to mix lime with fresh or rotten dung is to waste it; because the lime takes up and renders useless the carbonic acid gas which it contains. In like manner, a compost of fresh dung and weeds, green leaves, grass, turf, and green vegetables, without lime, is valuable; because all these substances supply abundance of *humic*. On the other hand, lime promotes the fermentation of peat earth, dry leaves, and every thing which contains hard woody fibre and supplies *humic* in quantity." (*Quart. Jour. Agr.*, vol. iv. p. 623.)

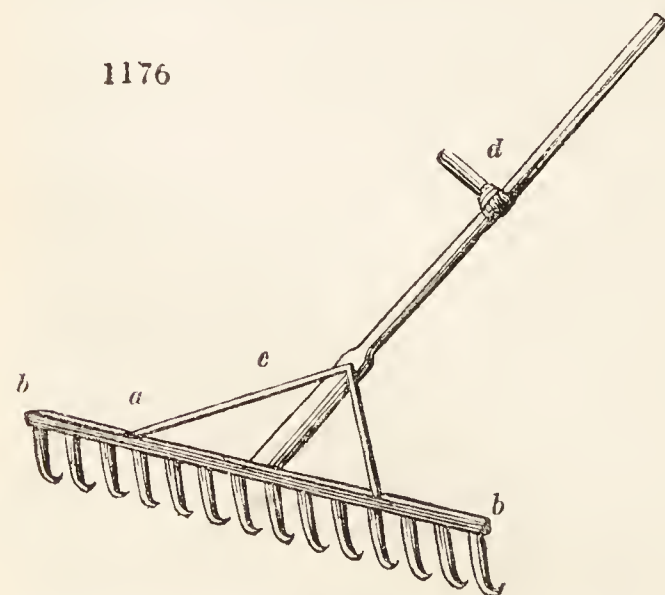
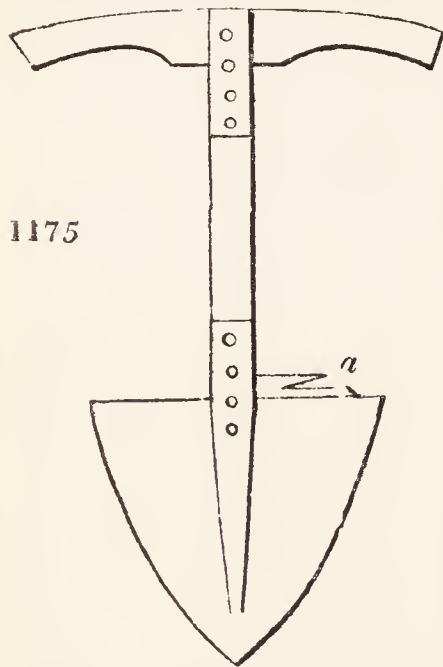
8084. *Such are the two leading theories* of the operation of putrescent manures; in the application of which, the farmer must take especial care not to err on the side of over-fermentation. It is a fact well known to gardeners that the black spit dung of old hotbeds, however moist, is not nearly so powerful a manure as dung in a comparatively recent state from the farmyard. For our own part, we are inclined to place the happy moment of application in a middle point between littery dung, which can only be lifted with a fork, and rotten dung, which can be easily cut with a spade. It will thus appear that we neither agree entirely with the theory of Sir Humphry Davy, which is also that of M. Chaptal in the edition for 1820 of his work entitled *La Chimie appliquée à l'Agriculture*, nor with the theory of *humic* of Klaproth, Sprengel, Thomson, and others.

8085.—2306. *Common salt as a manure*. Much as has been written on this subject, a pamphlet has recently appeared by Mr. Kemp, *On the Important Discovery of the Decomposition of Common Salt, for the Purposes of Manure: whereby an acre of land is prepared for the reception of any crop, at a cost of 10s. only*. The author states that, while farmyard dung produces twenty bushels of wheat per acre, decomposed salt will produce from thirty-five to forty bushels. He anticipates the whole produce of the kingdom increased fully one third by his discovery; but, before he makes it known, he expects to be remunerated by a handsome subscription, or by parliament. (See *Gard. Mag.*, vol. x. p. 233.)

8086.—2307. *Universal compost*. The following ingredients and quantities, it is said, will afford a sufficient dressing for an acre of land:—Fifty pounds of vegetable alkali, viz., English, Russian, or American potash; thirty-six pounds, viz., four gallons of oil of any kind; one hundred and twelve pounds, viz., two bushels of common salt; fifty pounds, or about a bushel, of quicklime. Mix the whole together, the alkali and salt having been previously dissolved in water, and reduce the whole to such a degree of liquidity that it may be poured from the rose of a watering-pot on as much light porous soil as will absorb it. After this compost has lain some time, it may be carted out, and spread over the acre to be manured; but if there is a proper water cart (*fig. 348*), this manure may be sprinkled over the land in its liquid state. (See *A Dissertation on Soils and Manures*.)

8087.—2308. *Saltpetre* has been tried on wheat, grass, and oats at the rate of $1\frac{1}{2}$ cwt. per Scotch acre. It was sown on grass land, on the 28th of March, 1829; and in ten days afterwards the grass was of a deep green, and was fit for pasturage before the rest of the field. It appeared also to improve the quality of wheat and oats by producing the more green vegetation. It ought to be applied when the land is moist. (*Highland Soc. Trans.*, vol. viii. p. 195.)

8088.—2444. *The under-foot spade* (*fig. 1175*.) should be made very strong; the shaft, or handle, should be square, with the angles rounded off, and strongly plated over where it is joined to the cross-angle at top, and to the blade below. The blade is about fourteen inches across, and twelve inches deep; quite perpendicular, with sharp cutting edges, and a hilt or piece of iron (*a*) riveted on for the feet. For the stuffing up of hedges, taking the top sods off drains, and various uses where strength is wanted, this spade will be found a most powerful instrument. (*Gard. Mag.*, vol. vii. p. 86.)



8089.—2452. *The corn rake* (*fig. 1176*), for using after the scythe, differs from the common rake both in form and dimensions. The head (*a*) of the corn rake should be made of fine ash; as light as possible, but strong enough to bear the driving in of a number of iron teeth; and it should be at least five feet in length, and feruled with iron at both ends (*b b*). The teeth should be seven inches in length, and four inches apart, and so curved at their points, that the weight of the rake may rest upon the curve, with the points of the teeth quite free of the ground, when the rake is held in a working position. The points of the teeth should be thin and broad. The handle of the rake may be of light fir, and it should be full six feet in length. An iron (*c*), passing from the handle on each side to the head, will prevent the latter from being twisted out of its position. A short handle, *d*, like the left handle of the scythe, and fastened at a convenient spot on the shank with an iron wedge, will facilitate the passage of the rake over the ground. (*Quart. Jour. Agr.*, vol. iv. p. 363.)

8090.—2462. *The Spanish hoe*. A modification

of this instrument has been made by Lord Vernon, to which he has given his name. (See *Gard. Mag.*, vol. ix. p. 508.) The hoe is manufactured at Sheffield of different sizes, and is an excellent implement for stirring the soil; because, from the pointed form of its blade, it goes much deeper with the same exertion of force than any of the thrust or draw hoes. It is, in fact, a kind of pick, like the hoe picks used in France and Spain in stirring the soil among vines.

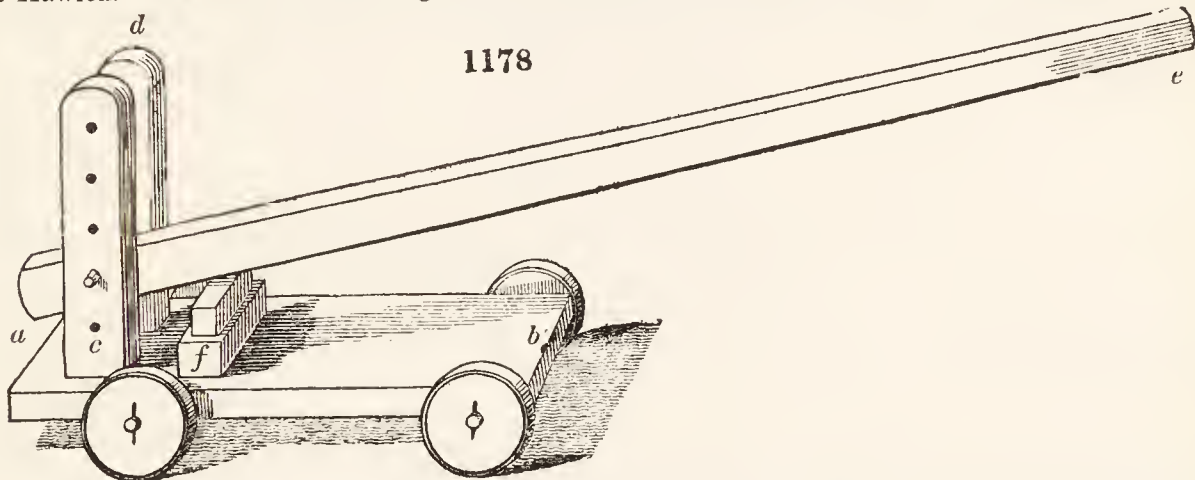
8091. — 2481. *The reaping-hook.* It is observed by the author of an excellent article on reaping with the scythe, published in the *Quart. Jour. of Agr.*, vol. iv. p. 350., as a remarkable circumstance in the history of mechanical science in Britain, that the art of cutting down corn crops should be so inadequately supplied with instruments. The reaping-hook, unlike every other mechanical instrument, depends entirely for its efficacy on the physical powers and dexterity of the labourer. The knife and the spade are as simple in their forms as the reaping-hook; and yet the former has been displaced by many mechanical contrivances, while the reaping-hook remains in all its primitive simplicity. Its continued use in the field is attended with immense loss of time and money; and, therefore, till an efficient reaping-machine is invented, it is proposed to substitute, in many cases, the scythe in its stead. The scythe is used, for this purpose, in France, Switzerland, and in many parts of Aberdeenshire, and it appears to be gaining ground everywhere.



8092. — 2489. *Howden's two-edged bill-hook.* (fig. 1177.) This hook is something like the letter S; it is all round sharp, and combines the powers of the carpenter's axe, the gardener's knife, the hedger's hook, the Highlander's broadsword, and the joiner's chisel. The blade is twelve inches in length, and three inches broad; the socket is eight inches long, and serves instead of a wooden handle when the instrument is used as a knife, bill-hook, or axe; when it is to be used as a chisel, it must be placed on the end of a long handle; and will then, either by pushing or drawing, remove small branches from the stems of tall trees. The long socket is made a little oval in the direction of the two edges, in order to let the operator feel where the edges are. The chief use of this instrument, however, is for dressing hedges, and for that a wooden helve, or handle, of about two feet in length, is best. (*John Howden, April 30. 1830.*)

8093. — 2551. *A press for compressing flour or meal into casks* is employed in North America, and it will be found described in the *Quart. Jour. of Agr.*, vol. iii. p. 559.

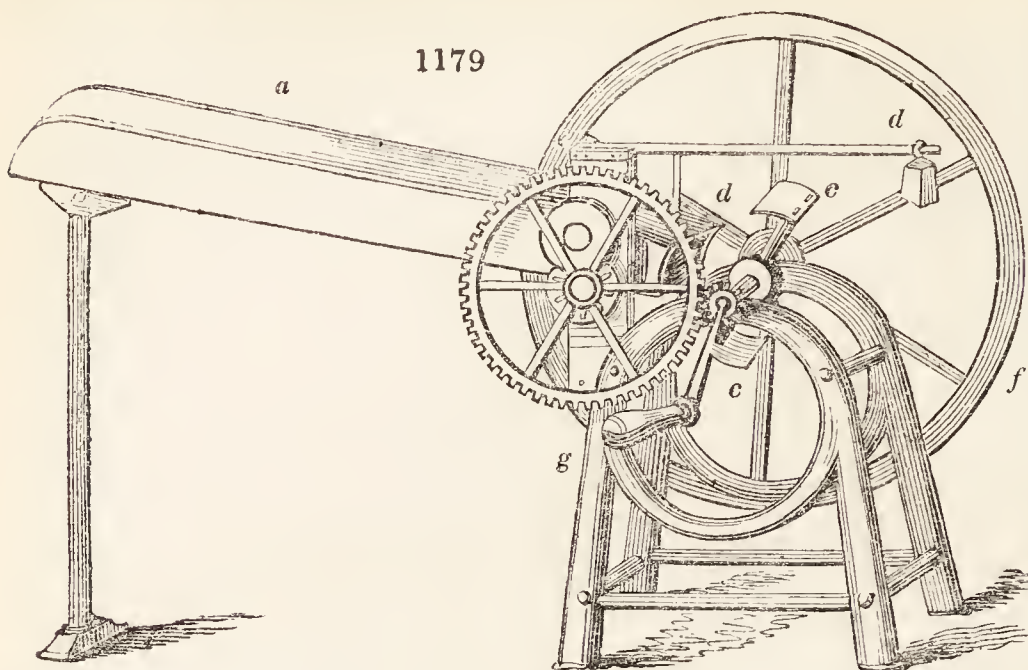
8094. *A machine for compressing peat* (fig. 1178.) has been invented by Mr. Walter Tod, of Longhope, near Hawick. The same machine might also be employed for compressing earth for building walls, and



for other purposes. A more powerful and elaborate machine has been invented by Mr. Slight, the Curator of the *Highland Society's Museum of Models*, and figured and described in the fourth volume of their *Transactions*; but the simple machine of Mr. Tod, we think, will be more useful in countries where the fuel is peat; and in new countries, where the emigrant might think it advisable to build the walls of his house of dry earth. This machine consists of two strong planks of wood fixed together at each end by cross bars, and mounted upon four wheels. Two pieces of wood (*c, d*) at the distance of two inches from one another, are mortised into the plank (*a, b*) at the end *a*, and at right angles to *b*. Between the upright posts (*c, d*) there is inserted a strong beam (*a, e*) twelve feet long, and secured with an iron bolt passing through the pieces (*c, d*), which have numerous holes to admit of raising and depressing the beam (*a, e*) at pleasure. Two boxes are then made, one of wood, and one of sheet iron fourteen inches in length, three and a half in breadth, and three and a half deep. These boxes have lids which just fit them, about three inches in thickness, to allow them to sink in the boxes by the pressure. Each box is to be alternately filled with peat newly dug, the lid adjusted, and the box placed in the machine at the point *f*; a man stands at the end (*e*) of the beam (*a, e*); and, as each box is placed in the machine at the point, *f*, he bends his whole strength and weight upon the end of the beam. By this means, an immense pressure is applied to the box by a single effort, and in an instant of time. Two women may fill and remove the boxes. In this way a man and three women could compress about eight cart-loads of peat in a day. One man digging, and a woman throwing out the peats, could keep the machine in full operation. The peats, when taken from the machine, are built up like small stacks of bricks, but so open as to admit a free circulation of air. The stacks put up in this way become perfectly dry, without being moved till they are taken home. If the machine just described were to be adopted for compressing earth, boxes of cast iron, full of small holes, would answer the purpose best. The pressure is so great, that the wooden boxes frequently give way, though strongly made, and secured with iron at the ends; and even the one of strong sheet iron has been bent. (*Highland Soc. Trans.*, vol. ix. p. 374.)

8095. — 2560. *Slight and Lillie's straw-cutter* (fig. 1179.) is considered to be the most perfect machine of this description that has hitherto been invented. In most of the other machines, the oblique position of the cutters, relatively to the hay or straw which they have to pass through, is found to be attended with difficulties to the workmen when replacing them after they have been taken off for sharpening. Messrs. Slight and Lillie have obtained the advantages of passing the knives in an oblique direction through the body of hay, without occasioning the slightest difficulty when these knives are removed to be ground. This is done by elongating the cutting-box into a nozzle, which is twisted until its orifice assumes an angle of about thirty degrees. By this arrangement, the entire efficiency of the machine is retained, while its construction and keeping in order are simplified, and its price is proportionately reduced. The framing is made entirely of cast iron: *a* is the feeding-trough, the rollers being only partially seen; *b* is the nozzle or cutting-box; *c, c*, the cutting bearers, with the cutters attached by their bolts; *d* is a lever and weight, which, through the medium of the bridge *e*, keeps a constant pressure on the feeding-rollers to counteract any inequality of feeding; *f* is the fly-wheel for equalising the motion; and *g*, the handle to which the power is applied. The small pinion on the fly-wheel shaft gives motion to the spur-wheel, which is mounted on the shaft of the lower feeding-roller, and carries also the lower feeding-pinion. This last pinion works into the pinion of the upper roller; and, both being furnished with very long teeth, they thereby admit of a limited range of distance between the rollers according to the quantity of feed. With one of these machines, a man, assisted by a boy to feed in the hay or straw, can cut

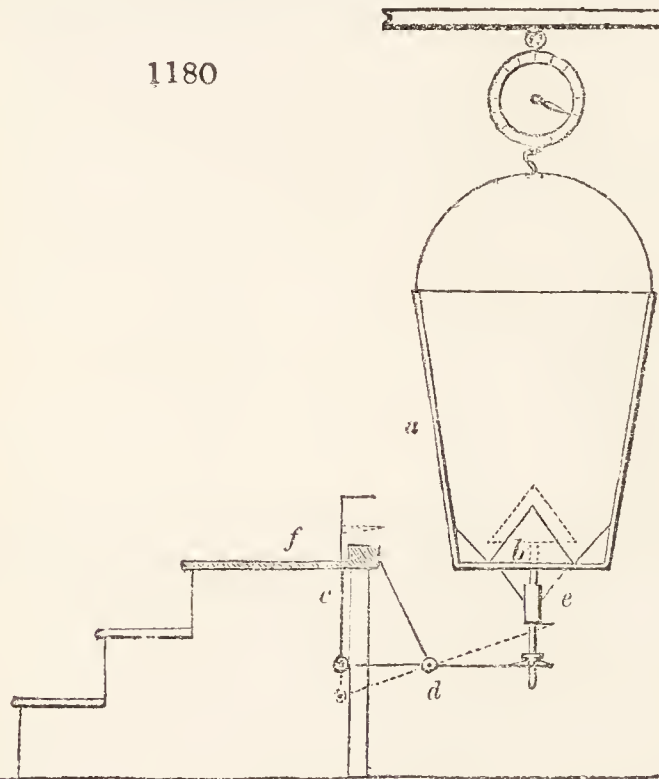
at the rate of eight stones per hour; and that quantity of cut hay is found to be sufficient for sixteen horses for twenty-four hours. (*Quart. Jour. Agr.*, vol. iv. p. 349.)



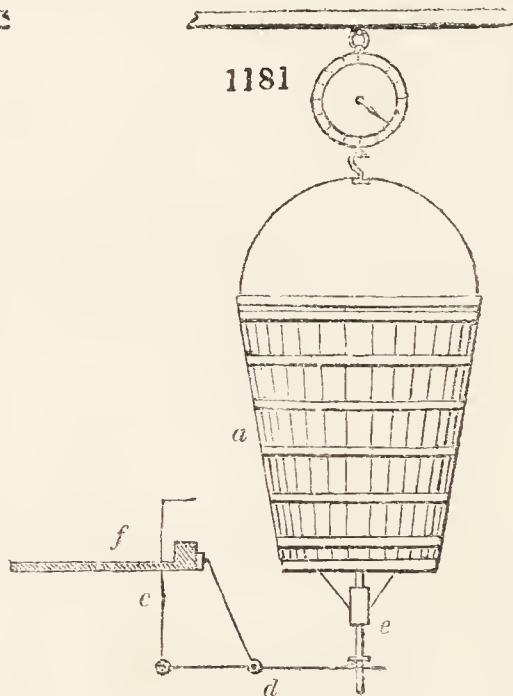
8096. — 2568. *Taylor's tub for measuring and weighing corn* represented in *figs.* 1180. and 1181. The tub (a) has a movable bottom (b), which, when it is desired to let the corn drop out, is raised by putting the foot on the pedal (c), which operates on the lever (d). The valve is worked by a spindle, which passes through the collar (e). The angles at the bottom of the tub are bevelled off to allow of the free egress of the corn into the sack below it. Of course the tub should be suspended high enough above the floor to allow the corn to escape; and

for this purpose a platform (f), ascended by steps, is required, which may be either fixed or movable. Up this platform the man walks who bears the sack of corn; and, the mouth of the sack being previously

1180



1181



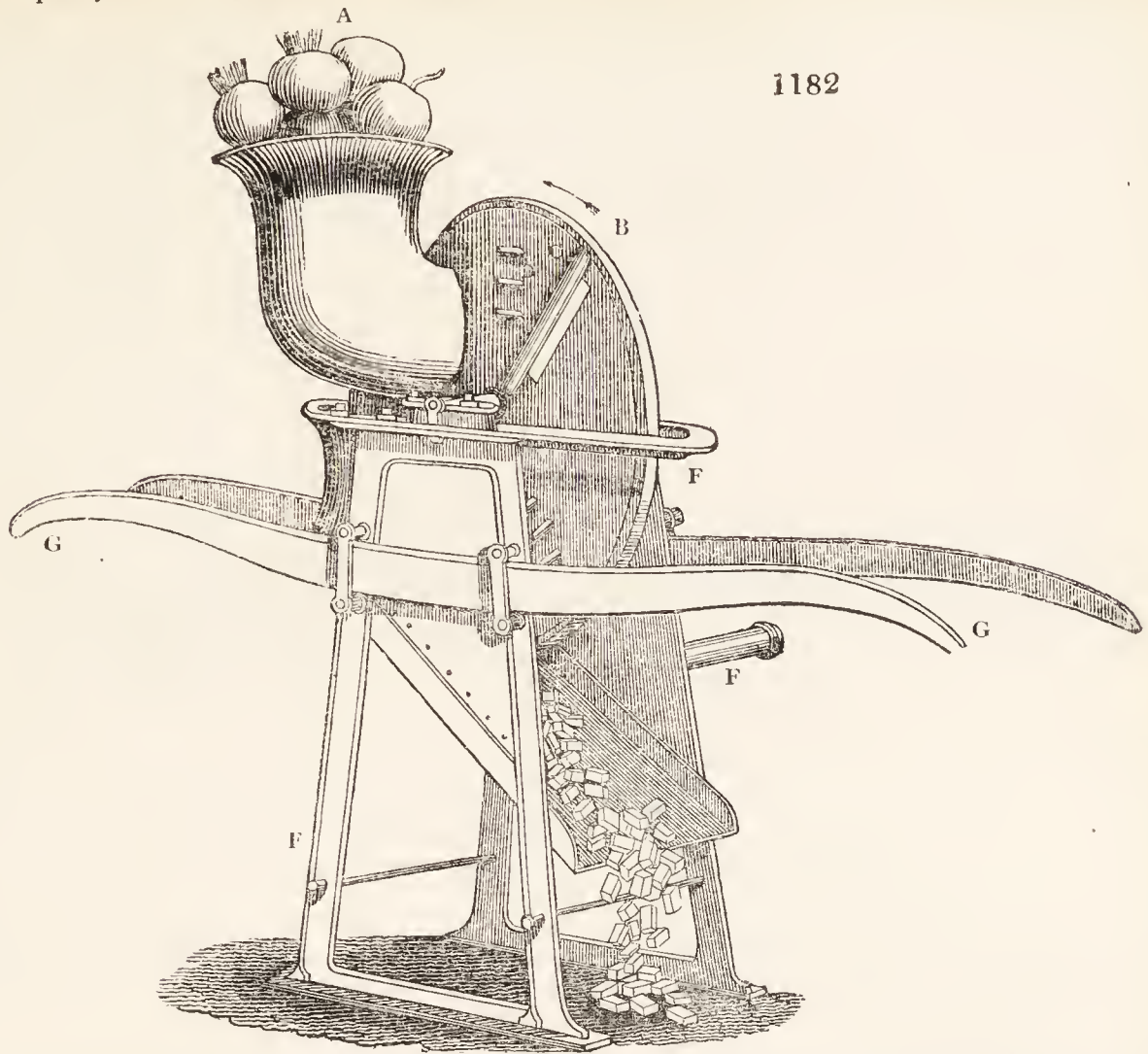
antied, he shoots the contents very gently and gradually into the tub. The precaution of shooting the corn into the tub gently and gradually is essentially necessary, as otherwise there will not appear to be full measure. The mode of weighing may be either by Marriott's dial engine, or by a steelyard beam; the former is the most simple. This tub was invented by Mr. Samuel Taylor, and is used in the extensive malting establishment under his care at Stokeferry, Norfolk. (*Gard. Mag.*, vol. viii. p. 467.)

8097. — 2571. *Baird's turnip-slicer.* *Fig.* 1182. is considered one of the best turnip-slicers in use in Scotland. It is made, when of full size, entirely of cast iron, and consists of a standard or frame to which is attached a hopper; the frame bearing a circular plate of east iron mounted on a horizontal axis, to which the winch-handle is attached. This plate is east with a thickened edge or rim, which gives it, when in motion, the effect of a flywheel. It carries two thin cutters or knives, set parallel to the face of the plate, and radiating from the centre. The thickness of the slices is regulated by the distance of the knives from the face of the plate. Each knife is preceded by three or more lancet-pointed studs, which, by slitting the turnips in passing, prepare the slices for falling in pieces when they are detached from the knives, at each revolution of the plate. This process goes on so long as the hopper is replenished with turnips, their own weight being found sufficient to hold them within the stroke of the knife. When potatoes are to be sliced, the disc above described is to be removed, and another substituted, differing from the first in having the cutting studs set closer together. In the figure, A represents the hopper filled with turnips; B, the disc of east iron that carries the cutters; C, one of the cutting knives, the opposite one being concealed by the framework; D, the lancet-pointed studs; E, the winch-handle, partially seen from behind the machine; F F, the framework of the machine; G G, two bars which slide into staples, and serve as handles by which it can be removed from one place to another. (*Highland Soc. Trans.*, vol. x. p. 51.)

8098. — 2578. *A turnip-sowing machine*, which sows two rows at a time, and deposits along with the seed a regular train of bone dust, is described in the *Quarterly Journal of Agriculture*, vol. iii. p. 718.

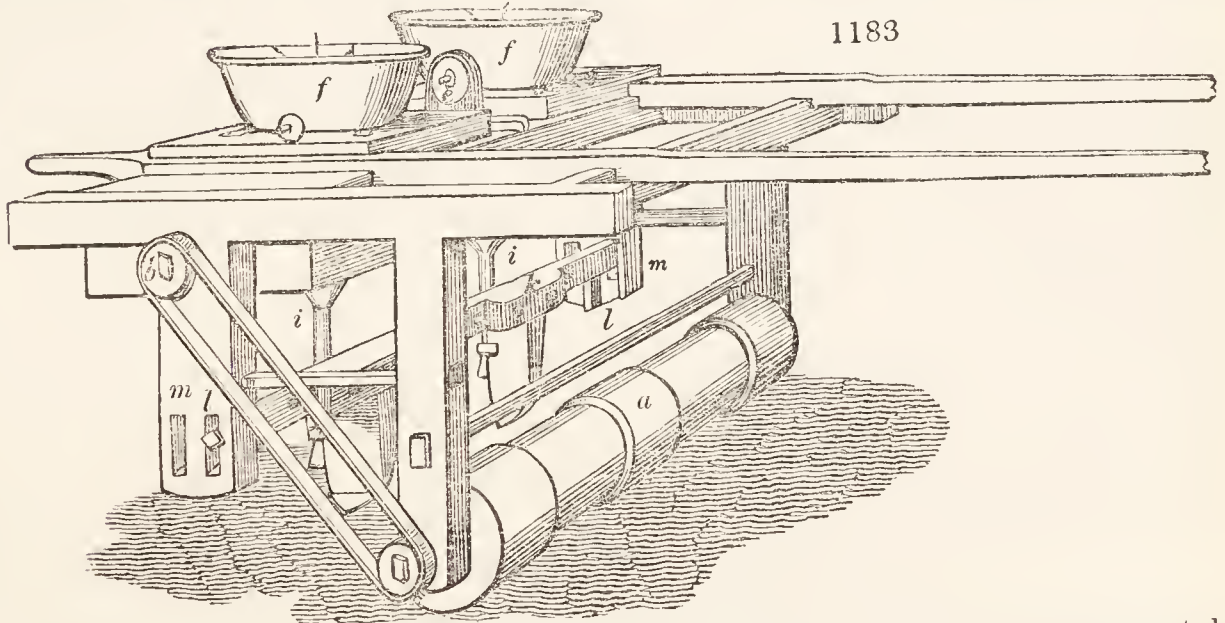
8099. *A machine for sowing carrots* was invented in 1833, by Mr. Daniel M'Naughton, farmer, near Irvine, in Ayrshire. *Fig.* 1183. exhibits the general appearance of the machine, which is similar to those in common use for sowing turnips; the essential difference lying in the apparatus adopted for discharging the carrot seeds from the seed-boxes. To the lower part of the framework is attached, in the usual manner, the great roller (a) serving to compress the prepared ridgelets, and also to communicate motion to

the other parts of the machine. This is effected by means of a leathern belt or a pitch chain, passing over a pulley at the extremity of the roller, and another of the same diameter at the extremity



1182

of the axle (*b*); which last, in the common machines, always carries the seed-boxes, but in this performs a double purpose. The first of these purposes is, that by means of two pulleys, which are

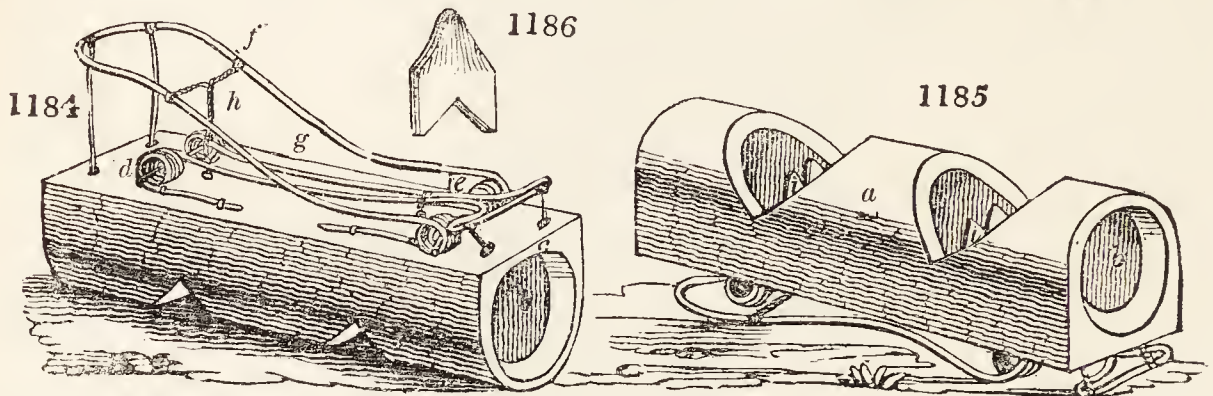


1183

not seen in the figure, it gives motion to two other pulleys (*e*) of the same diameter, mounted on small axles, which pass through the seed-boxes, and are each mounted with three plain wooden pulleys; the middle one is about six inches diameter, one inch thick at the centre, and is diminished to about half an inch thick at the edges; the other two are three inches in diameter, and of proportional thickness. The middle pulleys, unseen, are armed with six stout wire prongs, the extremities of which describe a circle of twelve inches in diameter; while the smaller pulleys (at *e*) are similarly armed with five prongs, extending to seven inches in diameter. The revolution of these armed pulleys keeps the seeds in continual agitation preparatory to their being propelled from the box. The second purpose to which the axle (*b*) is applied is, to carry a small wooden cylinder, placed immediately under each seed-box, of five inches in length, and three inches in diameter, armed with four prongs or claws, extending to a radius of three inches. In the revolution of these claws they penetrate successively into the orifice of the seedbox, and perform an operation of picking or scratching out the seeds in a regular succession. The seeds are received into the funnels (*i i*), and pass from thence down the tubes in the usual manner to the ground, where a rut is prepared for them by the coulter. The seed-boxes are made of sheet iron, or of tin plate of an elliptical form in the mouth; the diameter being about eighteen inches and twelve inches, with a depth of twelve inches; the cross section, taken either longitudinally or transversely, being also elliptical. The bottom of the box terminates in an oblong orifice of about six inches long by half an inch wide in the clear; the latter dimension being capable of extension, or diminution, by means of two pinching screws. Each box is covered with a movable lid, to prevent the seeds from being thrown out by the agitators. The funnels, with their seed tubes, are attached to the hind part of

the coulters, and are provided with an adjustment, by means of the slits and pinching screws in the collar bar (*k*) of the framework, enabling the operator to regulate the distance between the rows, while, by means of the slits and pinching screws (*m m*), he can regulate the depth of the rut for the seed-bed. The machine is convertible into a turnip drill by a very simple alteration. The seed-boxes and the claw cylinders are removed; and, in place of the latter, two barrel-shaped seed-boxes of the common construction are substituted upon the axle (*b*). It is then a complete turnip drill-machine. When, again, it is required for sowing onions, the turnip seed-boxes are removed, as also the collar bar (*k*). The axle (*b*) is then mounted with five barrel-shaped seed-boxes, similar to, but smaller than, those for turnips. A collar bar, with five permanent coulters, is placed in the slits (*ll*) of the frame. The coulters are perforated from top to bottom for the passage of the seed, terminating in the hind part of the lower extremity. Five funnels, corresponding to the seed-boxes, are inserted, one into the upper orifice of each coulters, and thus the machine is prepared for sowing five rows of onion seed. (*Highland Soc. Trans.*, vol. x. p. 203.)

8100. — 2581. *A moletrap in use in the north of Scotland* (fig. 1184.) consists of a block of wood (*a*)

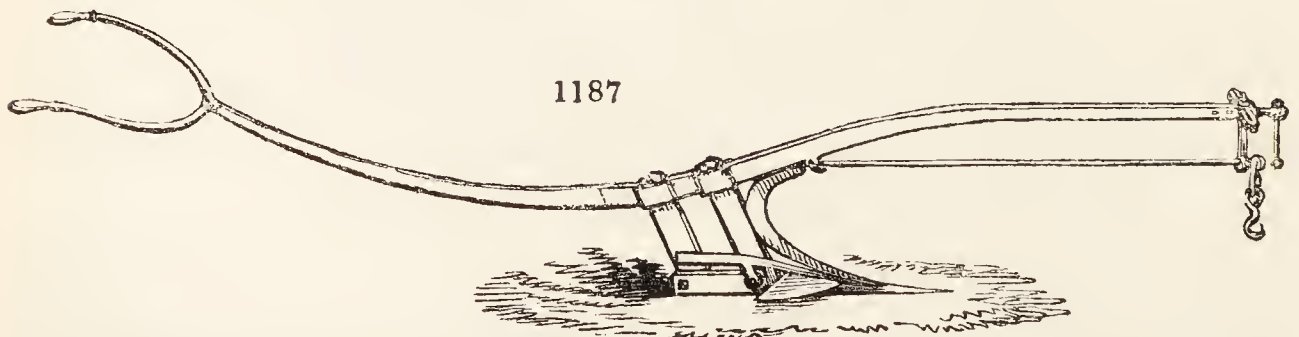


ten inches long, three inches broad, and three inches and a half deep; with a hole (*b*) two inches and a half in diameter, bored lengthwise through both ends. In the inside, half an inch from each extremity, is a groove for a wire loop to fit into, as in the common moletraps, only that the grooves are here cut quite through, having a small nail or pin of wire driven in through the middle, to keep the wires from rising above the wood. In the upper side of the hole, close by the grooves, three blunt-pointed pikes of wire (*c*) are fixed, so as to stand a quarter of an inch out of the wood. The holes for the triggers are bored in the centre of the upper side three inches from each end: in the lower side, opposite each trigger hole, is a small piece cut out, as in the common trap. The springs are made of iron wire, of about one eighth of an inch in diameter (*d* and *e*); and are exactly of the same form as those of the common mousetrap, having a cross wire fixed one inch and a half from the top of each spring (*f* and *g*); from which the catches, which are likewise made of wire, are suspended. These catches are retained by the plug or trigger (*i*) till it is displaced by the mole. *Fig. 1186.* shows the trigger separately. (*Gard. Mag.*, vol. viii. p. 299.)

8101. — 2691. *Mr. Small*, in the county of Berwick, and who removed to the Lothians, improved considerably on the English or Rotherham plough. But *Mr. Wilkie*, in the vicinity of Glasgow, has made far greater improvements on *Small's* plough, than *Small* did on the English one, or than that was an improvement on the old Scotch plough. The ploughs are now all constructed of iron in the western counties of Scotland, and are beginning to be made there by many country smiths, who always form them on *Wilkie's*, and not *Small's* model. (*Brit. Farm. Mag.*, vol. vi. p. 304.) In the *Mechanics' Magazine*, vol. xxi. p. 283, a table is given showing the mechanical analysis of a ploughing match held at Aylesbury in Buckinghamshire, in May, 1834; by which it appears that a furrow nine inches broad, and four inches and a half deep, required a power of draught of six cwt. and three quarters. The plough was the common sowing-plough of Buckinghamshire, called the foot plough, with a wooden mould-board, and drawn by two horses; and the soil was a stiff clay. The horses walked at the rate of two miles an hour. Now, with one of *Wilkie's* iron ploughs, the same furrow would have been turned over with a drawing power of four cwt. or less; and the horses, if of the proper kind for farm labour, would have walked at the rate of two miles and a half an hour.

8102. *The universal adoption of the common two-horse plough throughout England* would, *Laidlaw* asserts, add more than 3,000,000 quarters of wheat to the resources of the country. (*Quart. Jour. of Agr.*, vol. iii. p. 713.)

8103. — 2616. *The subsoil plough* (fig. 1187.), as designed and used by *Mr. Smith* on the farm of *Deanston*,



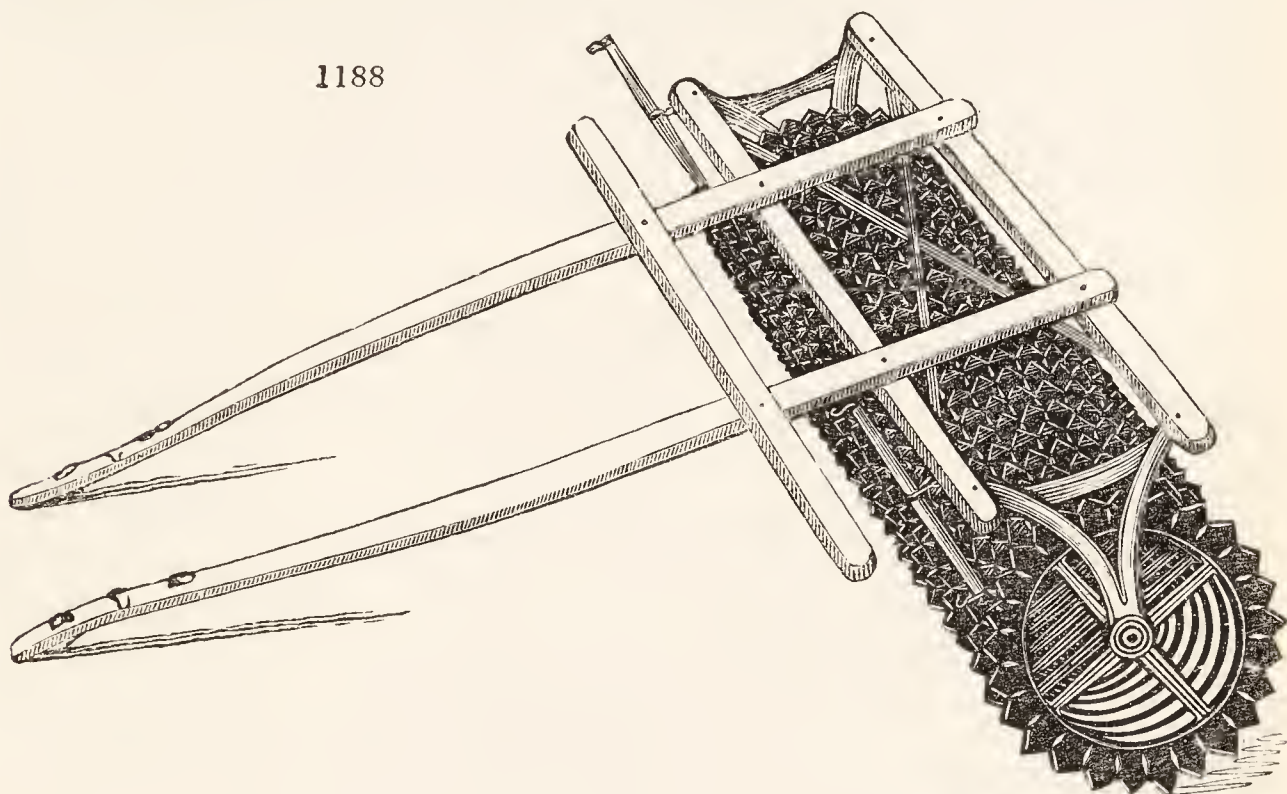
has been found peculiarly efficacious in rendering productive a sterile soil upon a tenacious bottom. It has been constructed so as to be of easy draught, and to penetrate to a depth of from sixteen to eighteen inches from the surface. It has no mould-board, and is intended merely to break and stir up the subsoil, without bringing it to the surface, or mixing it in the first instance with the incumbent soil. It is, in fact, a *horse-pick*, and readily loosens and throws out all stones not exceeding seventy pounds weight. It is drawn by four horses, two and two abreast, and it is held in the usual way by one man. In working, the common plough goes before it, taking a furrow ten inches by six inches, the subsoil plough following in the bottom of that furrow, and going deeper by ten or twelve inches. When this plough is applied on a tenacious bottom, and in conjunction with parallel drains about two feet and a half deep, and distant from twelve to twenty feet from each other, it produces wonderful effects in attaining a deep and dry soil; and, even on gravelly and sandy bottoms, its effects are considerable, and are especially apparent in the succeeding pasture. The cost of such a plough, with a soam, or main chain for the leading horses to draw by, is about 9*l*. The ordinary swingle-trees and harnessing suit, with straps over the quarters of the leading horses to bear up the swingle-trees to their buttocks, and a chain from the collars of the hind horses to bear up the soam-chain. This plough, with four horses, a ploughman, and a lad to drive, will do about an acre imperial per day, at a cost of about 1*l*.; no charge being made for the common plough, as the land would require a furrow at any rate. Such ploughs are made by *Robertson Smith*, at *Drip* (by *Stirling*), on the estate of *Blair-Drummond*. (*Highland Soc. Trans.*, vol. viii. p. 206.)

8104. — 2637. *Wilkie's improved friction wheel plough for two horses.* The invention of the friction wheel plough is claimed by Mr. Morton, an implement manufacturer of Leith Walk, Edinburgh, who "conceived the idea of introducing a wheel into the body or bosom of the common plough, about fifteen inches in diameter, to act as the sole," so far back as 1813. The average draught of the ploughs when the wheel was applied was reduced about one fifth, or to about two cwt. and three quarters. He manufactured a number of these ploughs both for home and foreign use; but in a short time, the farmers in the neighbourhood of Edinburgh left them off, giving as a reason for so doing, that they required more attention from the ploughman to grease the axle of the wheel, than the latter were willing to give. (*Gard. Mag.*, vol. vi. p. 209.) We may notice it, as a remarkable circumstance, that Professor Low, in his *Elements of Practical Agriculture*, published in 1834, describes only Small's plough, without mentioning Morton, Wilkie, or any other improver, and without once introducing the subject of wheel ploughs of any kind. The invention of the friction wheel is also claimed by Mr. E. Elliott, who lately managed a farm near Shepperton, in the county of Middlesex. In the *Farmer's Journal* for August 1. 1831, an account of an experiment is given in which Wilkie's improved plough without a friction wheel, was tried against the same implement with a friction wheel, and both against the common swing plough in use in Middlesex. Wilkie's plough, without the friction wheel, required four cwt. two quarters; with a friction wheel, three cwt.; and the common Middlesex swing-plough, six cwt. Notwithstanding experiments of this kind, it is an undeniable fact, that the old, heavy, clumsy Middlesex plough, which it appears requires twice as much strength to draw it as Wilkie's friction wheel plough, is still that commonly used in the county! We cannot suppose that any class of men would persist in a practice which they knew to be decidedly opposed to their own interest, and therefore we unavoidably conclude that in ignorance, or prejudice, or both, we must seek for the cause of these men so obstinately adhering to the practice of their forefathers. The truth is, as we have elsewhere observed, the farmers are the only class of Englishmen who do not read.

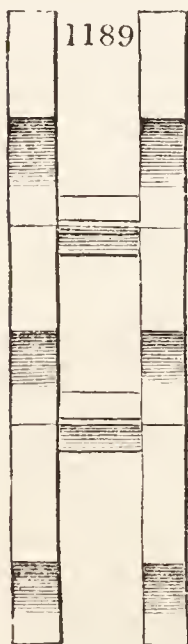
8105. — 2655. *The grubber, as compared with the plough,* Professor Low observes, will go over five or six times more ground in the same time; and to this extent there will be a saving by the use of it, where it can be substituted for the plough. It will go to the depth to which the land has been originally ploughed, or to any lesser depth which may be required. (*Elements, &c.*, p. 99.)

8106. — 2709. *Crosskill's clod-crusher roller (fig. 1188.)* is intended to effect the same objects as the

1188

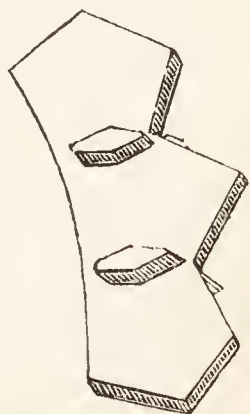


spiky roller. It consists of a number of segments, a perspective view of which may be seen *fig. 1190.*, and a vertical elevation of the same segment *fig. 1189.*, fixed on an iron axle six feet six inches long. Ploughed land once rolled by this machine is said to be reduced to a finer state than by two or three rollings and harrowings with the ordinary machines. It is drawn by three horses, and cleans itself, even when land is in the very roughest state. A number of these machines have been manufactured by the inventor at Beverley, and used by the farmers of the surrounding country. The price of a machine, including two iron road wheels to attach to it when not in use, is from 17*l.* to 19*l.* delivered in Hull.



8107. — 2711. *A cheap and useful watercart* is thus described by Mr. Donaldson in the *Farmer's Magazine*, vol. viii. p. 81. : — A barrel, holding 100 to 200 gallons, is placed on a pair of wheels and shafts in the usual way. A pump, three inches in diameter, is placed close by the side of the barrel; and to the under end of the pump is made fast a leather pipe of indefinite length, with a rose copper end, and in the pipe small copper or tin rings are placed, two inches distant, to prevent the external air from pressing together the sides of the pipe, and thus excluding the water. The cart being placed on the bank of a river, brook, or pond, and the pipe thrown into the water with the rose end immersed, a man will pump 150 gallons in ten minutes, without the trouble of having a road into the bottom of the river, and with the great advantage of the horse standing dry, and not plunged into three feet of cold water on a winter day, in the usual way of filling by ladle and standish. A stop-cock is fixed behind for discharging the water. When the cart is travelling, the leather pipe lies over the barrel, fastened by two iron catches. The barrel being filled, and driven to the place required, the leather pipe is immersed in the barrel by a

1190



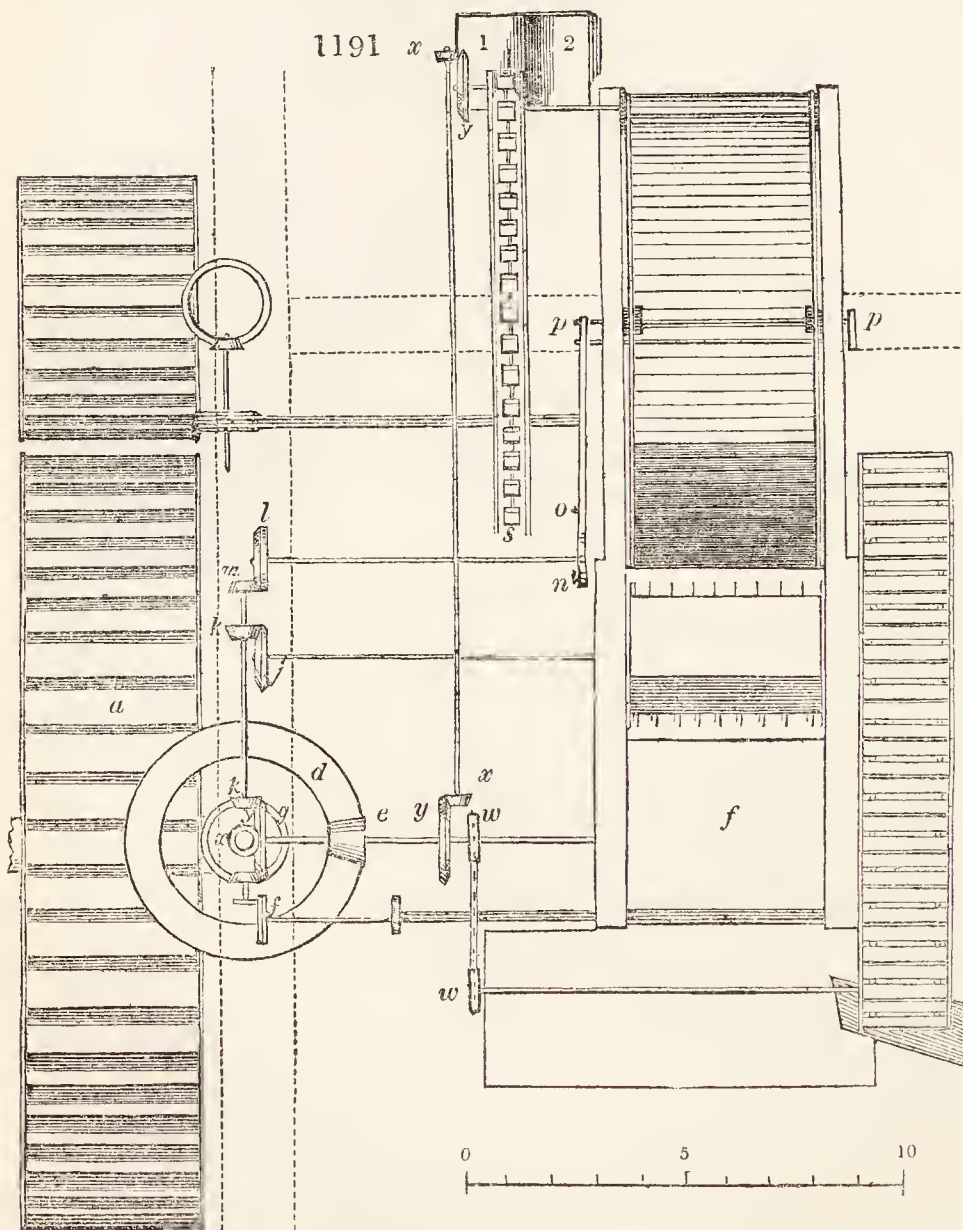
hole in the top, sufficient to admit the rose end. A small iron rod screws down by the side of the piston rod, upon the upper valve, and shuts in fast. A rising main, with a check valve, is opened between the two buckets in the pump, upon which is screwed fast a leather pipe with a copper tube on the end. One man directing this pipe, and another pumping, converts the cart into a sort of fire engine, that may be

very useful in cases of emergency, throwing the water forty feet horizontally, and over any house of two stories, any haystack or corn-rick; it is also very useful for garden walls and fruit trees. By increasing the size of the barrel, and by applying more power, a very sufficient engine may be made, and answering other purposes at the same time.

8108.—2731. *Mann's reaping machine* was invented in 1820, but neglected till 1826, when it was improved; and in 1832 it was exhibited at an agricultural meeting at Kelso. It differs from Bell's reaping machine in being drawn instead of being pushed, and in depositing the corn in a continuous swath nearly at right angles with the line of direction, and on the side opposite to the standing corn. Both these are advantages which we hope will not be lost sight of by the mechanist who may at some future time make such a reaping machine as shall come into general use. An engraving, with descriptive details, of Mann's reaping machine will be found in the *Quart. Jour. Agr.*, vol. iv. p. 250.

8109.—2773. *The construction of threshing machines* is everywhere very imperfect, even in Scotland, where they were first invented, and where machines of the largest power, impelled by water or steam, are erected at great expense. The editor of the *Quarterly Journal of Agriculture* has the following judicious observations on this subject:—"Were threshing machines constructed on correct and unerring principles, like the machinery of a timepiece or of a steam-engine, or even of a flour mill, the advantage to the farmer would not only appear in the shape of cleaner threshed straw, and of economy of time and labour, but the millwright himself would derive great advantage in the certain possession of materials, which would enable him to erect threshing machines that would suit the particular localities in which they were to be placed. There is no way of arriving at this perfection, but by the institution of experiments to ascertain what may be the simplest construction of the threshing machine, and the best mode of applying the least quantity of moving power to execute the desired work satisfactorily. These desiderata would produce the advantage of threshing the corn at the least cost. Threshing machines are of so durable a nature that they are not often renewed; but for that very reason they should be constructed in the best manner at first. A set of patterns could be made from the results of these experiments, and lent out to those makers in the country who could grant security that they would only erect machines which were conformable to these patterns. In the course of time the country would be stored with efficient and easily moved thrashing machines. The ill-judged desire of the farmer to have a machine that will not cost much money often leads the millwright to adopt expedients in its construction which he is conscious are not suited to work well together. This is one reason, among many others, to prove the propriety of landlords erecting threshing machines at their own expense, upon their farm-steadings, and of giving the tenants the use of the mills, as well as the steadings, and of obliging them to keep the machines in repair, as in the case of the buildings." (*Quart. Jour. Agr.*, vol. iii. p. 986.)

8110. *The threshing machine at Wynnstay*, the seat of Sir Watkin Williams Wynn, Bart., is considered one of the most complete in Britain. It was erected by the late Mr. John Gladstone, of Castle Douglas, Kirkcudbrightshire, about the year 1812. This machine separates the corn from the straw, and delivers both straw and corn into their proper places, without the assistance of manual labour, with the exception of feeding. The site of the mill is on a declivity, and the barn has three floors or stories; the upper-

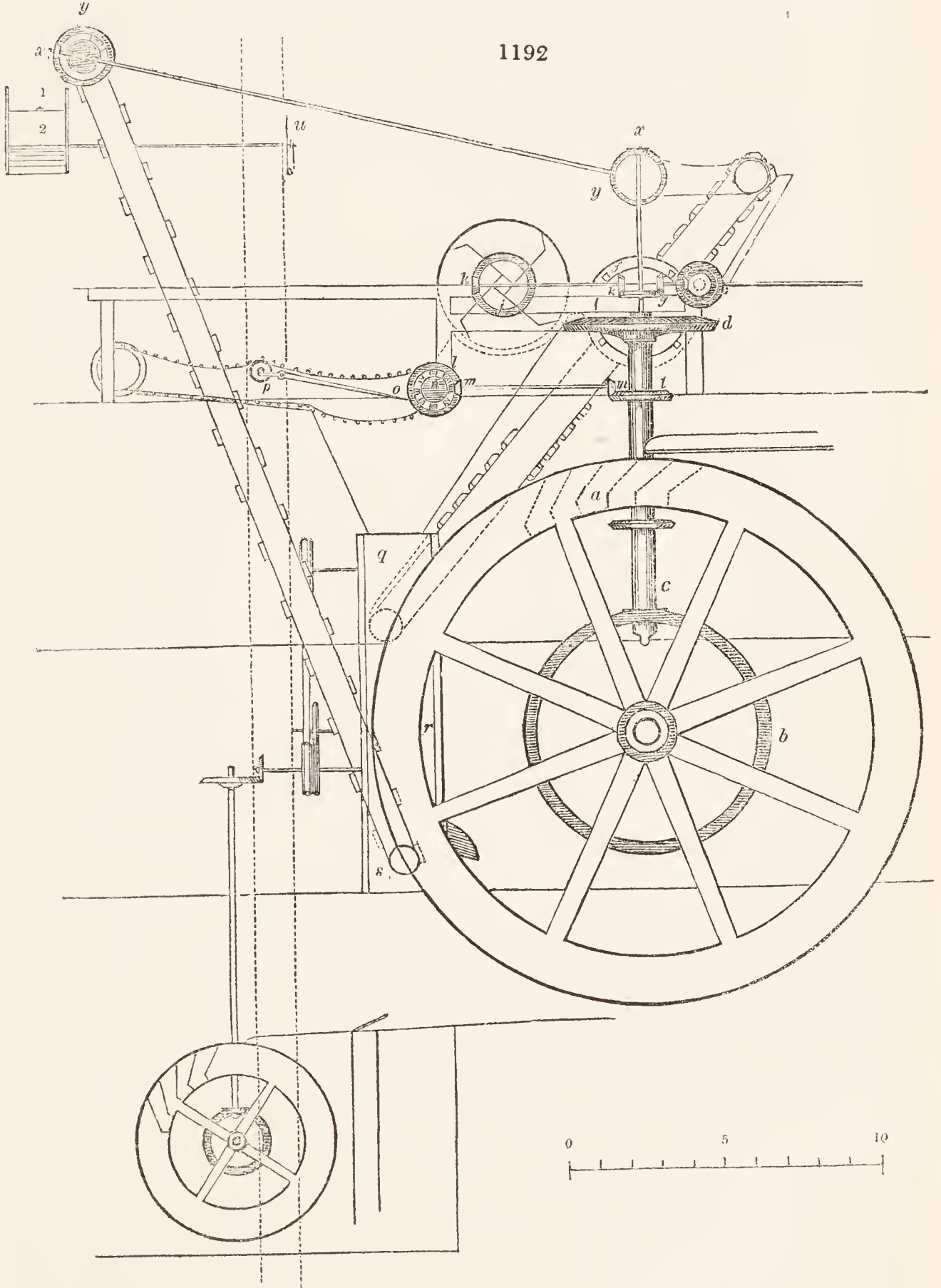


most of which opens into the stack-yard, making it very convenient for carrying in the sheaves: the second one contains the first winnowing machine; with a chaff-house, partitioned off under the stair, and descending to the floor below, with a door into the straw-house, and one into the cattle-yard. When the corn is only to be passed through the first winnowing machine, the corn elevators and second machine are thrown out of gear, and the corn delivered on the second floor, where the bruising machine is fixed. The under floor contains the second winnowing machine with the lower end of the corn elevators. If necessary, the clean corn may be delivered on this floor, instead of into the elevator trough: the ends of both machines are inserted in the chaff chamber. The corn is put between two grooved rollers, when the grain is beaten out of the ear by four beaters fixed on the threshing cylinder, and thrown into the rake or first shaker, when it falls through the sparred bottom into the winnowing machine hopper, while the straw is raked forward and thrown upon the travelling shaker, where it is thoroughly shaken, and conveyed into the

straw-house. The corn passes through the first winnowing machine, when it is cleared of its chaff, short straws, &c.: the latter is thrown into a set of elevators which carries them up to the feeding-table, to be

threshed over again with the unthreshed corn. This is a very useful appendage to a threshing-mill; it takes all the refuse from the fanners, which generally accumulates about a barn floor (or is carried up by hand), whereas the elevators carry all away, and thereby leave a clean barn. The corn passes through another pair of fanners, and from thence into the corn elevator trough, and is carried from thence into the granary and thrown into the weighing machine, which is connected with an index in the barn on the partition walls facing the man at the feeding-table, which shows the quantity threshed very nearly. The machine occupies part of three floors. The water-wheel is in a house beside the barn, and in a room above the wheel is a Scotch barley-mill, and beyond it is a very complete saw mill, both driven from the same wheel, which can be detached when the threshing part is at work, and the threshing part, when the saw or barley mills are wanted. In the middle floor is an oat bruiser driven from the upright shaft: it can be put out of gear if wanted.

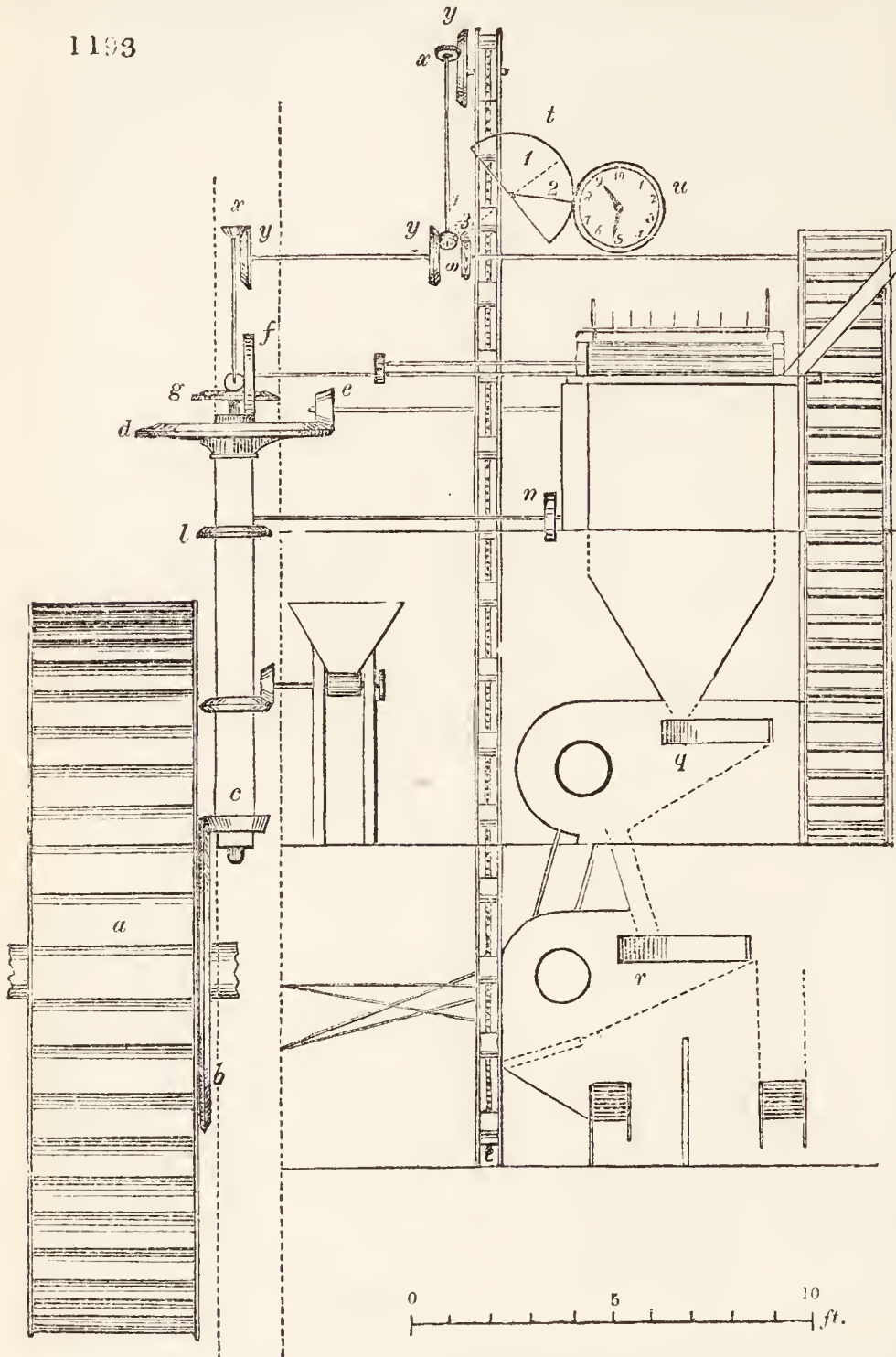
8111. *Description.* In *figs.* 1191, 1192, 1193, *a* is the water-wheel, eighteen feet in diameter by four feet wide; *b*, a pit wheel, eight feet in diameter, which works into a pinion, *c*, of fifteen inches in diameter fixed on the upright shaft; *d*, a bevel wheel, five feet in diameter, which turns the drum pinion, *e*, of nine



inches in diameter; *f*, the drum, or threshing cylinder, three feet four inches in diameter outside of the beaters, and four feet and a half long, with four beaters turning upwards with a velocity of 300 revolutions per minute; *a*, a bevel wheel, twenty-one inches in diameter, turning a pinion of five inches and a quarter diameter, on the axle of which is another pinion five inches in diameter, working in the face wheel, *i*, with two rows of teeth, one of thirty and the other twenty-four teeth; this pinion slides along its axle into either sets of teeth; for instance, into the one of the smallest number if the straw is long, and into the other if it is

short, loose, and irregular. The rollers are about three inches and a half in diameter; the wheels *g* and *j* are each twenty-one inches in diameter, working into the pinions *k k*, five inches and a quarter in diameter, which gives motion to the rake or first shaker at the rate of forty-five turns per minute: it is four feet in diameter to the extremity of the teeth; *ll*, two wheels, each twenty-one inches in diameter, with pinions, *mm*, five inches and a quarter each, which drive the travelling shaker

1193



that receives the straw from the rake, and conveys it into the straw-house. This shaker is composed of two endless pitch chains, worked by two stud wheels ten inches in diameter, with eight studs on each, on the same shaft as the wheels *m* and *n*, revolving at forty-five times per minute. These chains are kept stretched by two smooth wheels at the farther end in the straw-house: between the chains are fixed round wooden rods about two inches apart. *m* is a wheel with large teeth on its circumference, which, as it turns round, depresses the point of the lever *o*, and raises the end *p*. The lever is fixed on an axle which passes through to the other side of the shaker, with a short lever fixed on it to correspond with the lever *p*; on these levers, *p p*, rests a small shaft, on which is fixed on each end, under the chains, a small drum four inches in diameter, which supports the shaker in the middle, as the wheel, *n*, moves round. The point of the lever, *o*, strikes from tooth to tooth, and thereby keeps the small shaft, at *p p*, in motion up and down, which shakes the loose corn out of the straw, which is drawn back by the under returning rod into the winnowing machine hopper; *q* is the first winnowing machine; *r*, the second winnowing machine; both driven by a small water-wheel, six feet in diameter, and four feet wide: the water from the large wheels supplies this one. The

motion of the machine requires to be uniform, which cannot be the case if connected with the threshing part. It answers better to have a separate wheel for the machines. The clean corn passes into the elevators *s*; from thence it is carried up into the granary, and delivered into the weighing machine, *t*, by small elevators made of sheet iron, with wooden backs and bottoms fixed to a pitch chain, revolving round a studded wheel ten inches in diameter, and with eight studs at the upper end, and a small wooden roller at the bottom, at eleven turns per minute. The corn is delivered into the weighing-machine box, *l*, and accumulates until there is the weight of a measure, when the box turns on its axle, and the corn is emptied into the spout which conveys it into whatever binn it may be wanted in. At the same time the part *2* turns up, and is filled as the other, and, when full, descends as the other, and so on, while the threshing is going forward: *3* is a weight which slides up and down a rod fixed at right angles from the bottom of the weighing machine: if the corn is heavy, slide this up until it will balance a bushel of corn similar to what is to be threshed; if light, slide it downwards. From the axle of this box, a small rod proceeds to two small wheels behind the index, *u*, which turns two fingers that revolve round the face of this index; it is figured from 1 to 10. For every movement the weighing bucket makes, the longest finger moves over the space of one, and for every ten, the other finger moves one. At the end of the threshing, this finger will denote pretty accurately the quantity threshed: for instance, were the long finger at 5, and the short one at 9, there would be ninety-five bushels of corn in the binn; *x x x* are pinions five inches and a quarter in diameter, each working in wheels (*y y y*) twenty-one inches in diameter each, which give motion to the corn elevators, and likewise to the tail elevators by a pitch chain revolving round the stud-wheel *w w*, giving motion to the shaft of the elevators at eleven times per minute. The buckets are made of thin boards fixed on two pitch chains turned by two stud wheels ten inches in diameter at the upper end, and a wooden roller at the lower. (*J. Gladstone, Lead-works, Chester, Oct. 29. 1831.*)

8112. *Mr. J. Gladstone, civil engineer, Chester, to whom we are indebted for the foregoing plans and description, with reference to the improved form of the threshing machine, says, "I have always understood that it was to my father we are indebted for it in its improved state. In 1788, Mr. Andrew Meikle produced the first machine of the kind, for which he took out a patent. (See Repository of Arts, vol. x. No. 58.) This was simply a threshing cylinder with the beaters turning downwards, throwing straw and corn*

into a moving screen, which separated them in a very imperfect manner; so much so, that I have heard the machines were given up, or going into disuse, simply on account of the beaters striking downwards; if the ears escaped the beaters immediately on passing through the rollers, they were bent under them, and laid close to the interior of the cylinder case, and thereby evaded the stroke of the beater. In 1793, my father made his first machine, similar to that of Mr. Meikle, with this difference, that the threshing cylinder turned upwards, and as the corn came through the roller, it lay upon the cylinder, and, being exposed to the stroke of each beater, none escaped being threshed." (See *The Stewartry of Kirkcudbright Agricultural Report of 1810.*)

8113. *The late Mr. Gladstone, of Castle Douglas*, added the shaker to the threshing machine in 1794, and what he called a fetterer, for breaking off the awns of barley, soon afterwards. In 1798, he made a threshing machine, to be driven by windmill sails. In 1799, he invented the draught chains used in threshing machines, to equalise the pressure of the draught on the horse's shoulder. In 1805, he added a travelling shaker to the threshing machine, and soon after, a contrivance for conveying the corn from the fanners into the granary, and weighing it at the same time. By another piece of machinery the corn may be accurately measured. "On reviewing the whole," the writer, in the *Report of the Stewartry of Kirkcudbright Agricultural Society for 1810*, observes, "it is impossible not to perceive how vastly superior the machines of Mr. Gladstone are to those first contrived by Mr. Meikle, and what distinguished services he has thus rendered to the interests of agriculture. The machine is now competent to the threshing not only of one, but of every, species of grain. It is adapted of itself to separate the straw from the corn, and convey it perfectly shaken into the straw-house; to clean the corn effectually to weigh and measure it accurately; and to lodge it securely in the granary. If driven by water, the adoption of the chain bucket outer wheel saves an inner one, formerly deemed indispensably necessary, and simplifies the machinery; if by horses, the person feeding it can manage without a driver from within, and assign to each horse an equal share of the draught, or such a proportion of it as may be supposed adequate to his strength. Much diminution in the expense, as well as much improvement in the mode, of farm management has thus taken place. What was the work of several months, can be performed more perfectly, and with more ease, in as many weeks; and the labour of the winter season can now be devoted to more valuable purposes, to the collecting and formation of manures, and the better preparation of the land for the reception of the seed."

8114. — 2811. *Edifices in use in agriculture.* In the *Encyclopædia of Cottage, Farm, and Villa Architecture*, we have gone into this subject in greater detail than could with propriety have been done in a work embracing so extended a view of agriculture as the present volume. In that work we have not only given a great variety of the very best plans for farmeries, or farm-houses, which have been executed in Britain within these few years; but we have given detailed plans, sections, and specifications of all the component buildings of a farmyard, and of their fittings-up, fixtures, and furniture. In the *Architectural Magazine*, which may be considered as a perpetual supplement to the *Encyclopædia of Architecture*, all the improvements which may be made in architectural buildings will be recorded as they occur. We have given in this Supplement, § 8157., a plan of a farmery from the former work, which embodies all the latest improvements.

8115. — 2847. *Barn floors*, to be proof against the ascent of rats from beneath, should be formed of wood. "The sleepers upon which the floor is laid, should rest upon stone and lime building, raised two feet from the ground, close to the barn wall; and the mortar and stones must be packed close to the upper edge of the sleepers, up to the deals of the floor. According to the width of the barn, the sleepers should rest also upon one or two supports of stones, so hewn as to permit no footing to any vermin; and which will support the middle of the floor. By this contrivance, the space from the floor to the ground is made too deep to permit any small animal standing on its hind legs and gnawing the floor, while dogs or cats can easily pass under it." (*Quart. Jour. Agr.*, vol. iii. p. 995.)

8116. — 2876. *Labourers' cottages.* Having entered on this subject at length in our *Encyclopædia of Cottage, Farm, and Villa Architecture*, and there given numerous plans, accompanied by descriptions, specifications, estimates, and critical remarks, we shall not here repeat any thing which has appeared in that work. Nevertheless, as the improvement of the dwellings of country labourers is what we have most at heart, next to the education of their offspring, we cannot let pass this opportunity, without contributing something farther to the subject: we shall, therefore, give one article, entitled the *beau idéal* of an English labourer's cottage, by a most benevolent and enlightened clergyman, who adopts the signature of Selim; and another on building cottages with mud walls, by a professional man, Mr. Wilds, of Hertford, who, having been in North America, is deeply impressed with the importance of this kind of knowledge to emigrants, who, at present, too frequently build their houses of wood, and who, consequently, sooner or later, suffer from accidents from fire, or, what is almost as bad, live in continual fear of doing so. To these we shall add the design of a stone-walled agricultural labourer's cottage, recently built, along with a number of others of the same kind, on the estate of William Lawrence, Esq., in Gloucestershire.

8117. *The beau idéal of an English labourer's cottage.* The leading feature in the exterior of a labourer's cottage, should be a picturesque simplicity, which is a sort of medium between superfluous decoration and unmeaning plainness. This appears to be the only character of which a cottage is susceptible; for, as plainness is uninteresting, so it offends our sense of propriety to see a building of this description bedecked with costly fantastic ornaments, which are evidently unsuited to the simple unrefined habits of humble life. But a picturesque simplicity is seldom the pervading character of modern ornamental cottages. They are often decorated with turrets and battlements in the castellated style of Gothic, or in the monastic style, with elaborate painted windows, crosses, and pinnacles; nay, instances have occurred where the two styles have been united in the ornaments of a cottage dwelling. It cannot be denied, that a picturesque effect is produced by this mode of embellishment; all I contend for is, that such ornaments are altogether unsuited to a dwelling of the lowest order. Should it be objected, that, if we reject this mode of decoration, we must have recourse to ruin and decay to produce a picturesque effect; I answer, that as much of this effect as we may require may be produced, I think, by irregularity of form and outline; and irregularity is, in fact, the only effect aimed at by the use of Gothic ornaments. But as my object would be only a picturesque simplicity, I should discard useless and inconvenient irregularity. In so small a building as a cottage, a slight irregularity would be sufficient to give it a picturesque character, and the simplest embellishments would give it an ornamental effect; and this, I conceive, is all we require to produce what I understand by picturesque simplicity. Though I am an advocate for simplicity, however, in cottage architecture, I would in some measure sacrifice even simplicity to the picturesque; because the beauty of a neighbourhood frequently depends upon the style of the labourers' dwellings. These are the prevailing buildings in all rural scenery. They are occasionally so placed and associated with surrounding objects, that they present the most striking features in the landscape; and the effect of particular scenes is not unfrequently produced by the forms and situations of the cottages. Hence, a picturesque exterior is one of the chief requisites in an ornamental cottage; but it should be a simple pleasing style of picturesque, which does not interfere with internal comfort and convenience; produced by slight irregularity of form, and by unobtrusive and appropriate ornaments. I am not at all disposed to sacrifice internal comfort to outward effect. I think a picturesque exterior may always be united with a comfortable interior; and I now proceed to give the description of a cottage in which I shall endeavour to exemplify the union above alluded to.

8118. *Site of the cottage.* As the comfort of the inmates and the general effect of a building depend materially on its site, the situation of a cottage is the first thing connected with it that requires consideration. A general rule for the situation of a cottage is, that it should be properly supplied with water; be

dry, airy, and sheltered; and admit of a sufficient allotment of garden ground adjoining the house. And I am an advocate for rather a scattered village, because, among other advantages, it affords an opportunity of erecting the cottages in proper situations. A damp situation is the principal thing to be avoided. It is a nuisance in all cases; but especially to a labouring man, who cannot afford to spend any thing in draining, or much in fuel; whose health is his only source of wealth, and to whom it is necessary, both for health and comfort, that he should have a dry home to come to, after long exposure and severe exertion in the open air. Besides being dry, the site of a cottage should be airy and sheltered. Every dwelling should have a proper circulation of air around it, or it cannot be dry; and a cottage should be sheltered, that it may be warmed with less expense of fuel: the shelter should be so placed, however, as not to interfere with a full exposure to the sun. We will, therefore, suppose our cottage placed on a gentle eminence in the neighbourhood of other dwellings; and sheltered, in part, by higher ground at a distance, by a wood, or by groups of trees, and in part by its own orchard and outbuildings; some of these so placed as to appear above the roof, but leaving it fully open to the south. The situation would be more desirable if a stream of water happened to run near, or if it adjoined a common, or a public road; and it would thus possess the advantages of dryness, shelter, and cheerfulness, besides others which are of consequence to the general effect of the building to be erected upon it.

8119. *Style of the cottage.* Having fixed upon the site of the cottage, the next thing to be considered is, in what style is the building to be erected; for even a cottage, I think, should present some appearance of architectural style. I have already contended that the Gothic is inappropriate to a dwelling of this description, and a building in the Grecian or Roman style, upon so small a scale as a cottage, must be plain and formal, and deficient in picturesque effect, unless it be an elegant and costly edifice. There remains, therefore, only what is called the old English style, which is, I think, the proper style of architecture for an ornamental cottage. It admits of great irregularity and variety of form; and is suited to houses of all dimensions. Its ornaments may be adapted to the smallest dwellings; the irregularity it allows in the exterior, may be made conducive to internal convenience; and it has this peculiar advantage, that we have many beautiful models of old English cottages in all parts of the kingdom. It has, also, this additional recommendation, that it is not an expensive style, and may be executed in almost any kind of material. A cottage in this manner may be built of stone, brick, flint and chalk, or even of wood and plaster; and the building may be so formed, and the materials so disposed, as to give a picturesque and decorated effect, without the use of any expensive ornaments. The desired effect will be given by the tall chimneys; by the high pointed gables, with, perhaps, small pinnacles at the angles; by the mullioned windows and the labels over them; by a projecting porch of one or two stories; and by the stringcourses round the building. In this style much of the ornamental work might be of wood. For instance, the whole of the upper story might be formed of a wooden framework, filled in with brick or plaster. This wooden framework would project beyond the wall which supported it, and produce a pleasing effect of light and shade, and a variety of ornament might be given by the form of the frame itself, which shows on the outside, and by the arrangement of the bricks, or by the patterns impressed upon the plaster, with which the interstices of the frame are filled up. In these half timber houses might be introduced a kind of wooden oriel window, which is one of the most striking ornaments in many old cottages. The gables over such a building might have handsome barge boards, with carved pinnacles at the points. These pinnacles, if small and in good proportion, would be in keeping with a mode of building which admits of a great variety of embellishment, and is well suited to a district where stone and other substantial materials are scarce and expensive. As it possesses these recommendations, we will adopt the old English style for our present purpose, and suppose the cottage erected on a dry, airy site, well protected from the prevailing winds, and surrounded by its garden, orchard, and out-buildings. It would, of course, present one regular front. This we will suppose divided into two equal parts by a porch of two stories in the centre: in the ground story of the porch might be an arched entrance; in that above, a neat mullioned window of two lights, with its proper label; and over this a low gable terminating in a simple ornament. On each side of the porch might be a mullioned window of three lights, placed immediately under the stringcourse, which divides the house into two stories; the low wall above these windows would be plain, as the windows of the rooms in the chamber floor would be most conveniently placed in the gables at the ends of the house. In the centre of the roof, behind the porch, would be the stack of chimneys, which should be tall, and rather the handsomest member of the building. It is the most conspicuous part of it, and the general effect of the whole would depend materially upon the form of the stack of chimneys. This front would afford an example of what I understand by picturesque simplicity. There would be a certain symmetry and unity about it; it would present no superfluous ornaments, nor any unmeaning irregularity. But still it might be made a highly ornamental cottage, and might contain many internal conveniences which are not always found in buildings of more pretension; and it would possess enough of the picturesque character to make it harmonise with the surrounding scenery.

8120. *Interior accommodation.* Such, then, would be the exterior of the cottage: what are the accommodations it should contain within? A comfortable labourer's dwelling should, in my opinion, consist of an entrance porch, kitchen, washhouse, pantry, and small cellar, a parlour or spare sitting-room, and at least three bedchambers. These apartments are all necessary for the comfortable accommodation of a family, even in humble life; and, as we are attempting to describe the *beau idéal* of a cottage, we must suppose it to contain all these conveniences, which we proceed to describe in their order. A porch, besides being an important ornamental appendage to a cottage, is necessary for the comfort of the inhabitants, to which it contributes by sheltering the entrance from wind and rain, and thus assisting to warm the interior. A cottage porch should be of small dimensions, the floor on a level with the rooms within, and raised a step or two above the surrounding surface. It should be paved and ceiled; and if it had a seat on each side, it would form a kind of summer-house, where the females would often sit at work in fine weather. Over the seats might be shelves, on which small tools might be put away, and seeds, onions, &c., placed to dry. There should, of course, be a scraper at the steps, and a mat within the entrance.

8121. *Kitchen.* From the porch you should pass through a small lobby to the kitchen, or common sitting-room of the family, which should be a sufficiently spacious, light, and airy apartment. The object of the lobby is, that there may be two doors between the living-room and the outer air, which will assist in keeping the room warm with a less expense of fuel. There are some defects, usually found in the interior of old cottages, which ought to be avoided when new ones are erected. I allude to the lowness of the rooms and doorways, damp floors, and smoky chimneys. If we were to judge of the people by the houses they inhabited, we might suppose the former generations of our "bold peasantry, their country's pride," to have been absolutely a race of dwarfs. For, if you would avoid a broken head, you must actually creep through the doorways of ordinary cottages; and, after escaping the perils of the doorway, a man of good stature can seldom stand upright in the house without being in danger of knocking his head against the bare rafters of the floor above, or against the bacon-rack, the scythe-blade, the reaping-hooks, and twenty other things commonly suspended from the ceiling. Now, these low rooms and doorways must be a continual source of annoyance to the inhabitants; and, therefore, I would lay it down as a general rule, that no cottage kitchen should be lower than eight feet, and every cottage doorway above six feet. Another common defect in cottages is, the dampness of the ground-floor. In the case of old cottages, the ground-floor is usually much below the level of the surrounding surface, and you generally descend into the house; and, even in modern cottages, the floors of the lower apartments are seldom sufficiently elevated. The consequence is, that, in many situations, the cottages are damp and uncomfortable for five or six months in the year; indeed, I know several cottages in which springs of water regu-

early break through the kitchen floors during the winter season. To avoid this inconvenience, I would propose, as another general rule, that the ground-floor of every dwelling of this description should be eighteen inches or more above the surface, and that the earth on the outside should be the same distance below the level of the floor. Under every brick or stone floor there should be a substratum of broken stone or flints, varying in thickness according to the nature of the soil and situation. On a damp site, it may be necessary to have this substratum two or three feet deep, with drains and air passages through it; and the earth should have a good slope from the walls on every side, so that the water from the roof may escape rapidly, and not sink into the foundation. Another prevailing misery in cottages is, a smoky chimney. This is a proverbial nuisance to every one; but it is especially so to a cottager, because, over and above the dirt and discomfort occasioned by the smoke, half the fuel is wasted in a fireplace which has not a proper draught. This nuisance in cottages generally arises from the large size and straightness of the flue, and from the lowness of the chimney on the outside, or from the currents of air occasioned by the bad positions of the doors and windows, which seldom fit close. From whatever cause it arises, a smoky chimney is a prevailing misery in labourers' dwellings, which a judicious builder may generally contrive to avoid; and I refer the reader to some sensible observations upon this subject in the *Encyclopædia of Cottage, Farm, and Villa Architecture*. After this digression, let us return to the cottage kitchen. As this is the common sitting-room of the family, in which most of the household operations are to be performed, it should be a light warm apartment, of a good size. We will suppose it sixteen or seventeen feet square, and eight feet high, having a window in the east and one in the west side. It would thus have the benefit of the morning and midday sun; an important advantage to a cottager, in whose domestic expenditure coals and candles are considerable articles. Stone is, I believe, the best material for the floor, as being most durable and easily kept clean, and in these respects greatly to be preferred to brick. Boards, besides that they are liable to occasion accidents by fire, could scarcely be kept clean in a cottage living-room, and would soon be worn out by the iron-bound shoes of the inhabitants. Of course the walls and ceiling should be neatly plastered and whitewashed, and there should be a proper skirting-board round the room, and attached inside shutters to the windows. The fireplace should be so situated as to be well lighted by one of the windows; and it might be a close or open fireplace, according as wood or coal happened to be the common fuel of the district. I observe that the old-fashioned open fireplaces are generally preferred by cottagers, on account of the snug warm seats they afford in the chimney corner, as it is called, and which is too often the only warm place in the house. I am aware that these fireplaces do not economise fuel, or afford the best means of warming the room; but they present some advantages to the cottager; that is, they are capital places to dry bacon in, and wet clothing. Either wood may be burnt in them on the hearth, or coal in a movable grate; and, as the fire is on or near the ground, it certainly diffuses a considerable heat around it. The mouth of the brick oven also generally opens in the back, or side, of the chimney, so that all the ashes and litter, together with the heat produced, are confined to one place; and, should this place be near the centre of the building, the mass of warm masonry must have the effect of raising the general temperature of all the apartments. In the coal countries these open fireplaces are not usually met with; but, where wood is the principal fuel of the peasantry (as it is in the district from which I write), I would indulge their prejudice in favour of an open chimney, and will suppose one in the cottage kitchen, with the mouth of the oven on one side of the back, and on the other a small copper set in an arch, having a flue through the arch by which the steam might escape up the chimney. It would be tedious to describe minutely the various articles of useful and ornamental furniture found in the kitchen of a thriving cottager; indeed, to those unacquainted with rural life it would be difficult to convey an idea of the multifarious collection often displayed in a room of this kind. A tidy labourer's wife is sometimes as fond of knick-knacks, and as proud of displaying her various stores, as the richest lady in the land. The peasantry have, in fact, many of the prevailing tastes of their superiors in wealth and refinement, and love to ornament their houses with plants and flowers, prints, and plaster casts, and ornamental china. The kitchen is frequently as much crowded with useful and ornamental furniture as a modern drawing-room. The mantel-shelf displays a range of flower vases, images, and painted busts of the favourite heroes of past and present times, mixed with some of the bright cooking utensils. The walls are sometimes thickly hung with coarse engravings, ballads, and printed papers, moral, religious, and political, and with various other things; among which are conspicuous the labourer's club rules, and his staff, or some peculiar implement denoting his occupation, such as the polished head of the shepherd's crook, the market-day carter's whip, or the spare flail of the thresher. The window is seldom without its collection of exotics, thriving surprisingly, some of them in spoutless teapots and other discarded vessels; and on the window seat, or on a shelf near, a little heap of books; the bible, in a neat cover, reverently placed apart from the rest. Even the ceiling is usually furnished with that desirable ornament, a well-stored bacon-rack, shoes, tools, bags of seeds, and a host of other things. But the pride of the cottage housewife is her dresser and shelves. Here she displays her little store of glass and earthenware of the better kinds, with her best plated spoons, her bright pewter plates, and clean wood trenchers, frequently arranged with considerable taste and effect. Some of the conspicuous articles will not, perhaps, bear a close examination; and are, in fact, useless; though "wisely kept for show:" but she contrives to hide defects, and the shelves often exhibit specimens of old glass and china, which a collector of such rarities might covet. There are, indeed, few more picturesque interiors than that of the well-kept kitchen of a thriving labourer who happens to have a tidy wife; and I have often been much pleased at the air of decent comfort, and at the decorated effect produced by the miscellaneous collection seen in a room of this description.

8122. *Furniture of the kitchen.* Among the more prominent articles of furniture in a thriving labourer's kitchen, the clock, I think, takes precedence of the rest in the owner's estimation, and its well-polished case is generally a conspicuous object. Next to this we may rank the best dining-table, often one of those interesting old oak tables with rounded leaves, and as many curiously-turned legs as a spider. The best tea-table, turned up, with its pillar and claw, in a corner; and the dough trough, with its clean white cover, would next attract attention. To these we may add the great arm-chair, with a patchwork cushion in the bottom, for the *man*, as he is emphatically called here, in which he sits in the evening in a sort of rustic dignity, surrounded by his wife and children, forming, in many cases, a happy, interesting group: the wife and elder girls at work, perhaps, while one of the boys is standing by the father, reading, or repeating what he has learnt at school during the day. I hope there are many such evening groups still to be found in our cottages, in spite of politics and the beer-shops. This reminds me of another piece of furniture which I should wish to see in every cottage; I mean, a shelf of useful and instructive books. You seldom enter a cottage without finding some books; indeed, as far as my observation extends, I should say that a taste for reading is becoming more general among the labouring classes; and it ought to be encouraged, as a source of instruction and enjoyment, which has a tendency to improve the morals and better the condition of the peasantry. What a wide field of knowledge and enjoyment is cut off from the labourer who is unable to read, or who has no taste for reading! Half the leisure time of such a person must be spent in drowsy indolence, or in the debasing scenes of the alehouse, to which he is almost driven in self-defence, to relieve the tedium of idleness and the oppressive vacancy of his mind: the want of this resource and comfort is severely felt by the uneducated labourer in times of sickness and old age, when a long active life is necessarily exchanged for a state of total inactivity. There are few of the rising generation entirely without education. The stores of knowledge will therefore soon be opened to all the labouring classes, and they should be encouraged to use them to their own advantage, by having their attention directed to useful and improving books. "A little learning," if not properly directed, "is a dangerous thing."

8123. *Back-kitchen and washhouse.* Besides the kitchen, or common living-room of the family, every

complete cottage should have a small washhouse, in which the brewing and washing, the dirty and all work of the family, may be done. Here I would have shelves for the saucepans, and other unsightly articles, used in cooking; also a set copper; and a proper sink, communicating, by a drain, with the dung pit or a cess-pool. Most cottages are without a washhouse; but a small place of this sort is absolutely necessary to every dwelling; as, without it, the living-room can never be tidy or comfortable, and, I may add, wholesome. For want of a washhouse, the cottager is compelled to hang up his dead pig, and even to salt it, in the living-room; and as there is no other place in which to do the dirty work, and put away the dirty things which must be used in every family, the room is generally in a litter, and has an unwholesome, disagreeable smell, which must be prejudicial to the health of the inhabitants. But what I would chiefly insist upon in the washhouse is a proper sink to receive the slops and dirty water. Very few cottages have any convenience of this kind; and consequently all the slops are thrown out at the door; and, you can scarcely approach a cottage, in many cases, for the abominations that surround it. Besides this, the entrance is commonly surrounded by a sort of impure air, which is extremely offensive and must be injurious to the inmates. No cottage, therefore, should be without a sink, communicating with a drain, which may carry the dirty water to a sufficient distance from the house. Even a pretty cottage will have a squalid, miserable appearance, when the door is surrounded by filth; and I have seen villages, with the houses built on each side of a narrow road, which were absolutely disgusting in consequence of the nuisance referred to.

8124. *A small larder or pantry*, having a window in the outer wall, should communicate with the kitchen or wash-house. This is a necessary convenience not often found in labourers' dwellings, in which the provisions are generally kept in nasty close cupboards, or on shelves in the living-room, where they are liable to get spoilt, and are exposed to dust, smoke, and all sorts of impurities. For want of a better place, even the beer or cider barrel is kept in the warm kitchen, and in such a situation the liquor, of course, soon becomes sour and unfit to drink. No cottage, therefore, should be without a cool airy larder; and a small place of this kind might be easily contrived in every dwelling, with little or no addition to the cost of building. As I am describing the *beau idéal* of a cottage, the owner of which might keep a cow, I will, in the present case, suppose the larder of a sufficient size to contain both the milk and provisions. We can scarcely expect a distinct place for each in a labourer's cottage, and it would be unnecessary. There might be separate shelves for the milk and provisions, &c.; hanging shelves for the small cheeses, which a managing woman would of course make during the summer season, even from her single cow.

8125. *Cellar*. If the floor of the larder were sunk the depth of a yard below the surface, the beer might also be kept in it; but a cottage would not be quite complete without a small cellar, to contain the beer, and the potatoes and other roots. A cottager with land would grow a large supply of potatoes and other roots, for his cow and pigs; and it would save a great deal of time, and prevent waste, to have the roots always at hand in the cellar, instead of burying them out of doors in pits, which, when once opened, are not secure against frost and wet. I would also recommend a cellar in every new cottage; because I look forward to the time when every labouring man will be able to brew his beer at home. A hard-working labourer requires a certain quantity of wholesome beer; and if he has not this at home, he is sure to go to the alehouse, where he gets into the worst company, spends in intemperance what is required for the maintenance of his family, and in many cases becomes a confirmed drunkard. It would be a work of charity, therefore, to encourage brewing among the labourers; and, as a means of promoting it in country villages, I would suggest a plan of having a small set of brewing utensils, for the use of the cottagers, in the care of a fit person, who would lend them, in the parish, under proper regulations. The cost of the tubs &c., would be inconsiderable, and might be easily raised by subscription among the wealthy inhabitants, or even among the cottagers themselves. A penny or two paid for the use of the tubs would be sufficient to keep them in repair. The want of tubs is one of the chief obstacles in the way of cottagers brewing, which this plan would remove. And I am persuaded it would succeed, as I find that even a whitewashing brush, kept to lend out, has been a great promoter of cleanliness.

8126. *The parlour*. Should this paper ever fall into the hands of a labouring man, he would probably smile when he came to this part of it, in which I am to speak of the parlour. Many persons will consider a parlour an unnecessary luxury in a labourer's dwelling: it would be seldom used perhaps as a sitting-room, but as a spare room it would be a great convenience in the case of a large family, and should not be omitted in an attempt to describe a complete cottage. Most thriving labourers are in the habit of receiving their distant friends and relations, at certain seasons, such as the village feast, at "the tides," at christenings, &c. The parlour would be useful on such occasions, both as a sitting-room and additional bedroom, as it would be also in case of sickness, or death. If for no other reason, I should be an advocate for a spare room of this kind in every cottage, as a receptacle for the dead. As cottages are at present, there is seldom any possibility of separating the dead from the living, when one of the inmates dies: when such a calamity occurs, the corpse must be placed either in the sitting-room or bedroom; and I have known instances of a large family sleeping for several nights together in the same room with a corpse, even when death has been occasioned by an infectious fever. To my feelings there is something unspeakably terrible in this dreadful mixture of the living with the dead; and if the idea be so appalling what must the reality be to those who suffer it! A small parlour, therefore, containing an occasional bed, would prevent the necessity for this most disgusting consequence of death in a labourer's family; as, with the possibility of making up an extra-bed for some of the inmates, one of the bedrooms might generally be appropriated for the reception of the body, between the death and the funeral. I would have the parlour a plain comfortable room, ceiled and plastered, with a stone or boarded floor. It should, of course, have a small fireplace, and attached inside window-shutters. Besides the chairs and table, the furniture should comprise a closet bed complete, as the room would probably be more used as a bedroom than as a sitting-room. A corner cupboard to receive the best china and glass, a few groceries, &c., would also be useful; and a chest of drawers for the linen of the family would not be out of place. I should whitewash the walls, because it could be done by the cottagers themselves when requisite, and colour-washing is, of all things in this way, the most difficult to do well to the uninitiated. The cottager's wife would decorate the walls and the room generally with some of her best knick-knacks, books, flowers, &c.

8127. *Staircase*. As we proceed to the upper story, we must say something of the staircase. This, in old cottages, is generally the most awkward thing possible, and placed in the most awkward situation; a narrow, twisting, dark, and, to a stranger, a dangerous ascent, compared with which a common ladder would be luxurious, and usually leading into a bedroom which is a passage room to another, when there happens to be two. Our cottage must have a proper light staircase, ending above in a small landing, to which all the bedroom doors should open.

8128. *Bedrooms*. Every cottage for a family should have at least three bedrooms, so that the parents, and the children of each sex, might sleep in separate apartments. The rooms need not be large, but they should be light, airy, comfortable, each having a window that will open. They ought to be ceiled, plastered, and whitewashed; with boarded or plaster floors; and, if possible, a fireplace in each, in case of sickness, or merely for ventilation. I am rather an advocate for the plaster floors used in the north of England for cottage bedrooms, as they are a security against accidents by fire; and, when properly made, are more comfortable, and have a more cleanly appearance, than the rough ill-joined boards commonly found in cottage chambers. I have seen these floors nearly as hard as stone, and, when washed over with pipeclay, they have a very neat effect. It is unnecessary to describe the furniture, which, of course, should comprise the requisites for comfortable repose and cleanliness in a humble way. You seldom find bed-curtains in a cottager's chambers; I have heard them express a dislike to bed furniture; and, in a

tolerably warm room, it is, I think, a luxury we might all dispense with, as being rather prejudicial to health than otherwise. Cottagers generally use stump bedsteads, with head-boards; and I have observed in cottages ancient specimens of oak bedsteads, with curiously earved head-boards and legs. Old earved oak clothes-chests are also frequently met with, which would be valued by the antiquary. There are few cottages connected with labourers' dwellings which so much need reform as the bedrooms. In this neighbourhood half the cottages have only one chamber, and this sometimes a low miserable apartment in the roof, open to the thatch; with the walls unplastered, and without a window that will open; in fact, a place little better than a hay-loft. And here the whole family sleep; old and young, married and single, without even a curtain to separate the sexes. Can we wonder at the gross immorality which is so lamentably common among the young peasantry, when the sense of delicacy is destroyed even from infancy? I would therefore press this subject on the attention of all benevolent owners of cottages, and especially on our great landed proprietors, who are generally well disposed to contribute to the improvement of the peasantry. The first step towards the improvement of their morals must be to increase the number of bedrooms in cottages. Let me then urge this upon those whom it concerns, in the words of "Nature's sternest painter, yet the best," the poet Crabbe:—

"These thoughtless people part,
Nor let the ear be first to taint the heart."

8129. *General remarks on the interior.* Having described the interior of the cottage, let me pause and enquire, whether there is anything in the description which can be justly considered superfluous, and not absolutely necessary for the comfortable accommodation of a labourer with a large family. I am not aware of any thing to which a reasonable objection can be offered, unless it be the parlour. The idea of a cottage parlour may lead some to exclaim, "The man must be a fool! Who is to do the work, if labourers are to be fine folks, and sit in parlours?" My friend, are you not offended at a name? Let us change the high-sounding title of this room of all works, and perhaps you will not object to it. Call it the spare room, for instance; a place to be used for all sorts of purposes: for such it would be, in fact. Unless when the wife was confined, or any of the family happened to be recovering from illness, I will answer that it would not be used as a parlour above six times in the year. It would frequently be let as a lodging to an occasional labourer in the parish. In rainy weather, it would be degraded into a drying-room, and be filled with wet linen; and the floor would often be found half covered with onions and seeds laid there to dry. Do not the various uses to which such a room may be applied make it a desirable addition to a cottage, even though it may be called a parlour? If such an apartment would have a tendency to give the peasantry fine notions, I should be the last to recommend it. For I hate fine people of all sorts, and fine *poor* people above all others, because they have not even an excuse for finery. But though I would not give them notions unsuited to their station, I should be glad to see their habitations improved, and I know, from painful observation, that our cottages stand in need of improvement. They are, in fact, behind the times; and while the houses of every other class of society have been gradually increasing in comfort and convenience, the dwellings of the labourers are little better than they were a hundred years ago. Many improvements and conveniences in cottages have been suggested by others, which I forbear to notice; for this reason, that, while such conveniences are unattainable by persons of small independent property, it is in vain to expect that they will be provided for cottagers. My object has, therefore, been to describe the accommodation required in what would be called a comfortable labourer's dwelling, and to suggest practicable improvements which are likely to be effected; and I hope that there is nothing in the foregoing description which can be considered impracticable.

8130. *External appendages to a labourer's cottage.* I am next to speak of the external appendages to a complete labourer's dwelling, including the yard and outbuildings, the garden, orchard, and allotment of land. To account for some of the outbuildings which will be mentioned in the following description, I must remind the reader that, as I am speaking of a cottage of the first class, I must, of course, suppose the cottager to keep a cow; and that, besides a quarter or half an acre of land, for spade husbandry, (the quantity should be proportioned to the spare time of the labourer, and the quantity of manure he can collect), he would also be the occupier of about three acres of pasture. I am of opinion that it would have a beneficial effect upon the general conduct of the agricultural labourers, if there were a certain number of cottages, with land attached to them, in every parish, to act as a sort of stimulus to industry and frugality. Formerly the small farms presented this stimulus. The industrious, saving cottager had then a chance of rising a step above his original station in society; and a natural desire to improve his condition would act as a constant inducement to carefulness and activity. But now he has no such inducement. In most parts of England, parishes which were once divided into ten or twelve farms, of various extent, are now thrown into two or three large ones; the waste lands are enclosed or appropriated; and even the bare-worn common is, in many cases, denied to the hard-working frugal labourer, who happens to have saved enough money to set up a cow. How can we wonder, then, at the careless, improvident habits of the peasantry, when they have scarcely an inducement to be otherwise? But, under all their disadvantages, there are still a few labourers who save money; and is it not rather hard that they should be deprived of the opportunity of employing it profitably in the only business with which they are acquainted, that is, agriculture? Let us suppose a working man to be possessed of 50*l.* Almost the only way in which he could invest it safely, would be in a savings' bank, where it would produce him an interest of about 2*l.* a year. Now this is all very well; the principal sum is secure, and a certain 2*l.* a year is a desirable addition to a labourer's income. But it would take nearly his whole life to save up 50*l.*; and half that sum would produce a much greater income, and much improve his condition, if employed in some sort of business. In short, though the savings' banks have been a great benefit to the working classes, the small income produced by a sum of money placed there does not afford a sufficient stimulus to frugality. The interest upon their savings can add little to the comforts of the depositors; and, as to having a sum of money against the time of sickness or misfortune, they know that the parish must then support them; and though they might be induced to save, if by saving they could materially improve their condition, we must not expect them to save for the relief of the parish. But let us suppose a man to have saved only 25*l.*, and to have an opportunity of taking a cottage, with land enough attached to it to support a cow. He would probably invest his little capital in a cow, a couple of pigs, some poultry, perhaps, and a hive or two of bees; and, if he had tolerably good luck, and were a good manager, he would soon be placed in circumstances of comparative affluence, and would be infinitely better off with his 25*l.*, thus invested, than the other would be with his 50*l.* in the savings' bank. The great improvement in his condition would also be apparent to all around him, and would act as a general spur upon the carefulness and industry of his neighbours. Money in the savings' bank would not produce this consequence, because its effects are less apparent; in short, its effects are unimportant when compared with the comforts derived to a labourer's family from keeping a cow. But, besides being prizes to excite the diligence and reward the good conduct of the labourers, a few cottages, with land attached, would be a general convenience to the villagers, as a means of supplying them with milk; a luxury which, in my neighbourhood, is seldom tasted by the poor. Though living in the country, they are worse off than townspeople in this respect, as they cannot get it for money, unless on some particular occasion. The cause of this inconvenience is the large farms, and the want of cottagers' cows. A rich farmer is, of course, above selling milk, and there is no one else to sell it, unless there happens to be a small farmer in the parish, or the rich farmer lets his cows to the farmer or dairyman. It would not answer to sell milk in small quantities, and, as we have no cottage cowkeepers, the peasantry are deprived of a nutritious article of food, which it is almost impossible to do without. Wherever there are no cottagers' cows, the peasantry in general must be ill supplied with that important

necessary, milk. I offer these reasons for the opinion I have ventured to advance, that in every village a few cottages, with land to keep cows, would be desirable on many accounts. I do not say that every cottager should have a cow. Perhaps it would be better if all had them who can manage them; and it would be found, upon trial, that the number of these would not be large. A cow would be thrown away upon dirty, indolent cottagers, and there are many respectable ones so situated, that it would be more an inconvenience than an advantage to them to keep a cow. But I think there should be a few cottages with land in every parish, that the steady and industrious, and those who have an opportunity, may at least have a chance, of improving their condition.

8131. *The yard.* After this long digression, let us proceed to speak of the yard, a very necessary convenience to a labourer who keeps a cow. The wash-house should have a door opening into the yard, which ought to contain the pump, dung-pits, and all the out-buildings. The pump I would place as near the washhouse door as convenient; the dung-pit in the corner of the yard, farthest from the house; and to this pit the surface of the yard should have a gentle fall. It should, of course, be properly drained.

8132. *The fuel-house.* The first out-office to be mentioned is the fuel-house, a place in which the coals and dry wood may be kept, if necessary, under lock. The tools, and hogwash tubs, and many other things, may also be placed in this building, which is a necessary appendage to every cottage. It would be most conveniently placed joining the back part of the house, so that it might be approached under cover from the washhouse door.

8133. *The cowhouse and pigsty* should be near the dung pit, that the drains from both may be laid into it at little expense, and to save the cottager's time in cleaning out the cow stall, &c. The cowhouse need only contain one roomy stall and a calf-pen, with a small loft over both for the hay brought in for use. The pigsty to a cottage where a cow is kept should be divided into two, that the store pig, which a good manager would never be without, might be separated from the fatting pig.

8134. *If a poultry-house* should be required, I would place it either over or adjoining to the cowhouse, for the sake of warmth. But I am not sure that it would answer to a cottager to keep much poultry, unless in situations where there is a ready sale for eggs and chickens, and where poultry can be kept without being a nuisance to the owner and his neighbours. In a widely scattered village this may sometimes be the case, but where the houses are near together, the cottager's fowls are a continual source of dispute and annoyance. They are ill fed at home, and cannot stray anywhere in search of food without trespassing upon a neighbour's ground, where, in the absence of the family at work, they may devour or destroy half the produce of the garden. Where the houses are scattered, and a cottager has land of his own, or is near a common, on which they could have a run without trespassing upon others, perhaps it would answer his purpose to keep a few fowls; that is, if he can keep them out of his garden, but not otherwise. If water is near, ducks would be most profitable to a labourer, and more easily managed than hens.

8135. *Privy.* I do not recollect any other outbuilding actually necessary for the cottager's convenience, unless it be the privy, which might be either in the yard or in the garden, and, if desired, I see no objection to one in each place. But it is useless to talk of a separate convenience of this kind for males and females, till every labourer's dwelling has one. I believe that nearly half our cottages are without any place of the kind; at least it is so in my neighbourhood. For instance, out of sixteen dwellings near me, six only have the convenience alluded to, and three of the six conveniences have been erected within these two years. The want of such places must be a terrible nuisance to the cottagers; and I particularly recommend the subject to the attention of cottage owners.

8136. *General observations on exteriors.* As the fence of the yard and the outbuildings would add something to the cost of the cottage, I choose here to meet objections that I suppose, and recommend only the least expensive outbuildings, such as the cottagers, with trifling assistance, would very frequently erect themselves. The cowhouse would be the chief expense, and that would be little better than a common shed, walled up with any thing on three sides, and open to the south. But I would have a strong fence and gate to the yard, to be fastened well at night, that all the stock may be secure, as it would probably cost the owner at least a day's work when his cow or pig happened to get astray. I do not mention any place for pigeons in the yard, because a cottager could not keep them without constantly trespassing on his neighbours. There is an increasing prejudice against pigeons, which are certainly very troublesome to the farmer at certain times in the year. Dovecots are now much less frequently seen in farmyards than they were formerly, at least in the corn-growing districts: and if the farmers can no longer keep pigeons, of course the labourers must not. Where the cottage stands near a common, or among open green lanes, it would answer the cottager's purpose to breed a few geese, which are a profitable kind of stock, because, after a certain age, they almost take care of themselves. They would require to be secured at night; and, if the cottager keeps geese, he must add a house for them to his outbuildings in the yard.

8137. *The garden,* if well managed, is commonly the most striking feature about a labourer's dwelling, and there are many reasons why it should adjoin the house. In the present case we will suppose the cottage to be surrounded on two sides by the garden, and I would approach the front of the house through a narrow part of the garden which divides the house from the road; and this part of it I would devote chiefly to flowers and shrubs. I would train some ornamental climbing plants against the walls of the house, and a vine or pear trees, if there were proper situations for them, where the fruit would ripen and be out of the reach of the children. I observe, however, that excepting vines, fruit trees seldom thrive much against the walls of cottages; there are few labourers who know any thing of the art of pruning, and, being improperly pruned, the trees bear little, and seem not worth the time and trouble they require. Vines, however, do remarkably well against the cottage walls in this neighbourhood, and bear profusely in many situations, apparently with very little care or pruning. I am not qualified to lay down rules for the management of a cottager's garden, but I would venture to suggest, that it should not be too large; a small garden, well cultivated, being more profitable than a large one half cultivated. In fact, if he have an allotment of potato ground elsewhere, the cottager has no use for a large garden, as he grows and uses none but the commonest vegetables, which take up little room. He does not ever cultivate much small fruit. Strawberries and raspberries are very seldom seen in a cottage garden; and currants and gooseberries are not often abundant; so that a large garden is not requisite. I used to wonder formerly why the cottagers did not cultivate the small fruits in greater abundance, as they require so little trouble, and are so extremely useful. The reason for this neglect, given me by several labourers, is, that the children devour the fruit before it comes to perfection; in fact, they begin upon it as soon as it is formed, and very little is left to ripen. As cottage children are, of course, left a great deal to themselves, I believe it would be useless to attempt growing fruit where there is a large family, or in a closely built village. Where a cottager, therefore, cannot grow fruit, he ought, I think, to keep bees as a substitute for the profit of fruit. Indeed, no cottage garden should be without bees, placed in some warm retired corner, at a short distance from the house, for they are not agreeable neighbours. Bees are, I believe, the most profitable of all stock for a cottager, as the whole of their produce is valuable, and, except at swarming times, they are no trouble.

8138. *Orchard.* Besides the garden, it is desirable that every cottage with land should have a small orchard attached to it, especially in the cider countries; and, in extensive allotments of land, there are generally rough places, which, being of little value for any other purpose, might be converted into small orchards. Where there is no waste place of this description, I would plant the orchard immediately behind the garden, and contiguous to the house, that it may be easily overlooked by the owner; I would also rear a good hedge round it to keep out intruders, for young cottagers are as fond of sour apples as

they are of sour gooseberries; and though they can scarcely clear an orchard of apples as they would a garden of small fruit, they will do a great deal of mischief, if not guarded against. As it is scarcely possible to have too much fruit, and a peasant's orchard is not likely to be large, I would plant some fruit trees in the hedges of the garden and fields. Damsons and cider apples, and other common fruit trees, would do very well in the hedgerows, and would be very ornamental. I think a cottage orchard should produce apples, pears, and plums of various kinds, but chiefly apples. Fruit will sell every where; and it is desirable that a cottager should have as many ways as possible of making a little money. The landlord ought to furnish the cottage grounds with fruit trees, and a gentleman of landed property would do this at a very trifling expense, by having a small cottage nursery, in which his gardener might graft, and rear fruit trees of good kinds, to transplant, when fit, into the cottagers' gardens and orchards. Many labourers are fond of grafting; and, if the ground were planted with fruit trees at first by the landlord, the tenants would generally keep it stocked. I wonder our landowners do not see the advantages of planting their cottage grounds with fruit trees; by which they would increase the value of them, and place in the hands of the tenants the means of paying the rent. They would also give their cottagers an additional comfort, and greatly increase the beauty of our villages, by surrounding the houses with fruit trees, which are the most interesting of all trees. What can be more beautiful than a handsome apple tree covered with rosy blossoms in the spring, or loaded with golden fruit in autumn? It is picturesque even in winter, when its rugged massy stem and irregular branches are exposed to view. Indeed, a village with many small orchards about it is generally a pretty village.

8139. *Potato-ground.* The next thing to be spoken of is the allotment for potatoes, &c., without which no cottage would, in these days, be thought complete. But, of course, this allotment would be much smaller in the case of a cottager keeping a cow, than in that of a labourer with only a garden to attend to. The cowkeeper would have many little odd jobs to do connected with his cow and land, which would leave him not leisure enough to cultivate an extensive potato-ground besides his garden. Nothing pays a labourer so well as working for a master; consequently, a garden cannot answer to a cottager if he is obliged to lose time, as they express it, in order to cultivate it. A cowkeeper's ground for potatoes, &c. should therefore be smaller than that of another labourer, because the man will not have much leisure, and the wife will have less, as she will have the produce of the cow to manage, in addition to the ordinary cares of the family. But if the cowkeeper have not constant employment with a master, the case would be altered, and he would require as large an allotment as other labourers. He would probably cultivate his ground on a different plan from that followed by ordinary cottagers. He would not have space for a plot of corn, and it would answer his purpose better to grow cabbages, Swedish turnips, mangold wurtzel, or something that would be useful for the cow, on that part of his ground not occupied by the potato crop; indeed, a man who has a cow and pigs should consider their wants in his gardening almost as much as he does those of his family, and his pigs should nearly live on vegetables during the summer.

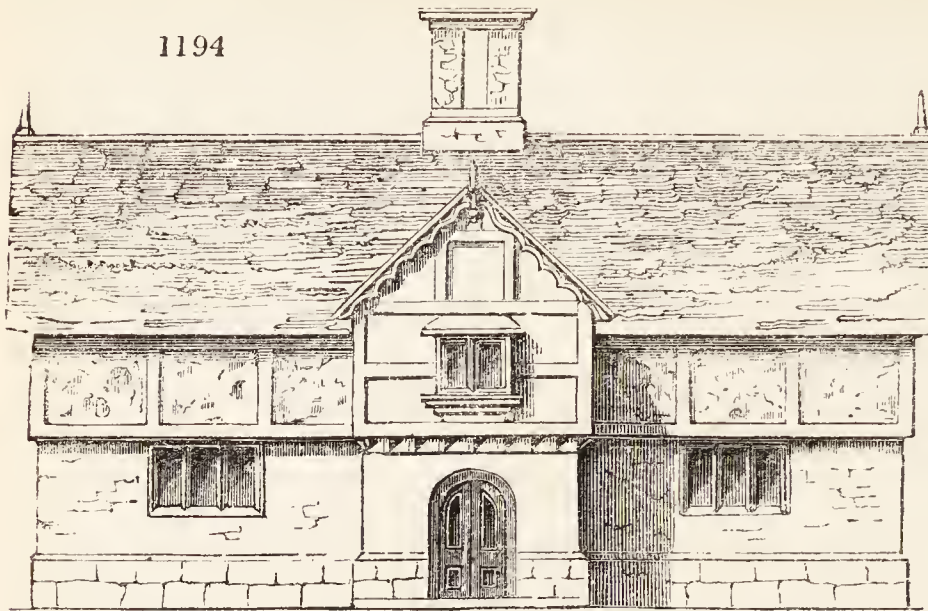
8140. *Grass land.* We conclude with a few observations upon the grass land which the cottager is to occupy for the use of his cow. This should be about three acres, divided into two enclosures. I believe three acres of fair grass land are generally considered the quantity required to summer and winter a cow; but, if a less quantity would be sufficient, of course the cottager would not desire more, as it would cause an unnecessary addition to his rent. He had better have rather too much land than too little, as the profit of a cow depends in a great measure on its being well fed. He would probably mow his fields for hay alternately, as he would not be able to manure very freely. He must, however, manure a portion of his grass land every year, or it would go back; and, if he were a good manager, he would be able to do this; for it is surprising what a heap of compost a managing person will collect who keeps a cow, and two or three pigs, and gathers every thing that can be converted into manure from the garden, the yard, the drains, and the roads about the premises. If he had not too large a potato-ground, a cottager, situated as I have described, would not be a good manager if he could not contrive to dress over an acre of his grass with compost every year; and this would be sufficient to keep it in heart if it were mowed every alternate year. There is one thing connected with allotments of land to labourers, which I would press on the attention of cottage owners, that whatever land is let to a labourer should be adjacent to his house. It should be remembered that the cottager's land is to be cultivated during the leisure time he has after having done an honest day's work for his master. His land, therefore, should be near his abode, that he may make use of all his time, half of which would be wasted in walking backwards and forwards if his land happened to be at a distance. If, also, his land were at home, he would spend many a half hour spudding thistles, or spreading dung in the field, or doing many little odd jobs, which would be left undone if the field were some way off. Moreover, it works a man too hard to have to walk a quarter of a mile, or more, to his extra-labour, after, perhaps, walking a much greater distance from the place where he works for a master. He would do half as much more work, and do it with more pleasure to himself, if he could do it at home, where he could immediately retire into the house when he felt fatigued. In short, if a cottager is to do any good with land, it should be within an easy distance of his home. Imagine the extra-labour occasioned to the cottager when he has to wheel out the manure, and bring home the produce of his land, distant, perhaps, a quarter of a mile from his house. Where the cottages belong chiefly to one proprietor, who is the principal landowner in the parish, it may generally be contrived that the allotment of land may adjoin the cottage, or be at least a convenient distance from it. A cottager can generally afford to pay as good a rent for land as an ordinary farmer; and, if he can afford to pay for it, he may reasonably expect to have it conveniently situated.

8241. *General observations.* I believe I have noticed most of the conveniences, internal and external, which in these times would be thought requisite to form a complete labourer's cottage. I am aware that the description given goes very far beyond the ordinary run of cottages, as they are at present. My aim has been to make it so; but I hope I have suggested nothing but what is absolutely necessary for the decent comfort of a family. My aim has also been to speak of practical improvements; and to show how the domestic accommodations of the peasantry may be increased at a moderate expense. There are many desirable improvements and luxuries suggested by writers on cottage architecture, which I have forborne to mention for this reason; because costly improvements are not likely to be applied to cottages; and it is useless to recommend luxuries for labourers' dwellings, which are not found in the houses of wealthy farmers and tradesmen, and even in those of the smaller gentry. Our peasantry, however, have no desire or taste for luxurious habitations. They wish for comfortable cottages; that is, dry, warm, and, above all, sufficiently roomy dwellings, in which their families may be conveniently accommodated, without violating the common decencies of life. If they had houses of this description, they would have every reason to be satisfied, and would be so, without unnecessary luxuries. And I hope the time is fast advancing, when the improvement which has taken place in the habitations of all classes above them will be extended to labourers' cottages.

8142. *As an example of an English labourer's cottage,* applicable to the above description, our correspondent has sent us the design shown in *figs.* 1194. to 1196. *Fig.* 1194. is the elevation; *fig.* 1195. the ground plan; and *fig.* 1196. the chamber plan. In *fig.* 1196. *a* is the oven; *b*, a small boiler; *c*, a closet for bacon or other things which require to be kept dry; *d*, stairs; *e*, a lobby; *f*, kitchen fireplace; *g*, parlour fireplace; *h*, washhouse; *i*, dairy; and *k*, shed for fuel, hog tubs, &c., opening into a yard, *l*. In *fig.* 1196., *m* is the parents' bedroom; *n*, spare bedroom, or bedroom for young or sick children; *o*, bedroom for girls; *p*, bedroom for boys; and *q*, a closet entered from the landing-place, *r*. The lower story of this cottage is supposed to be built of stone, or of brick with stone mullioned windows. The upper story to be a wooden framework, filled in with brick or plaster ornamented. The framework projects at the ends, and the gables have ornamented barge-boards. The window in the porch gable is an imitation of the old projecting wooden windows, of which there is a great variety, and they

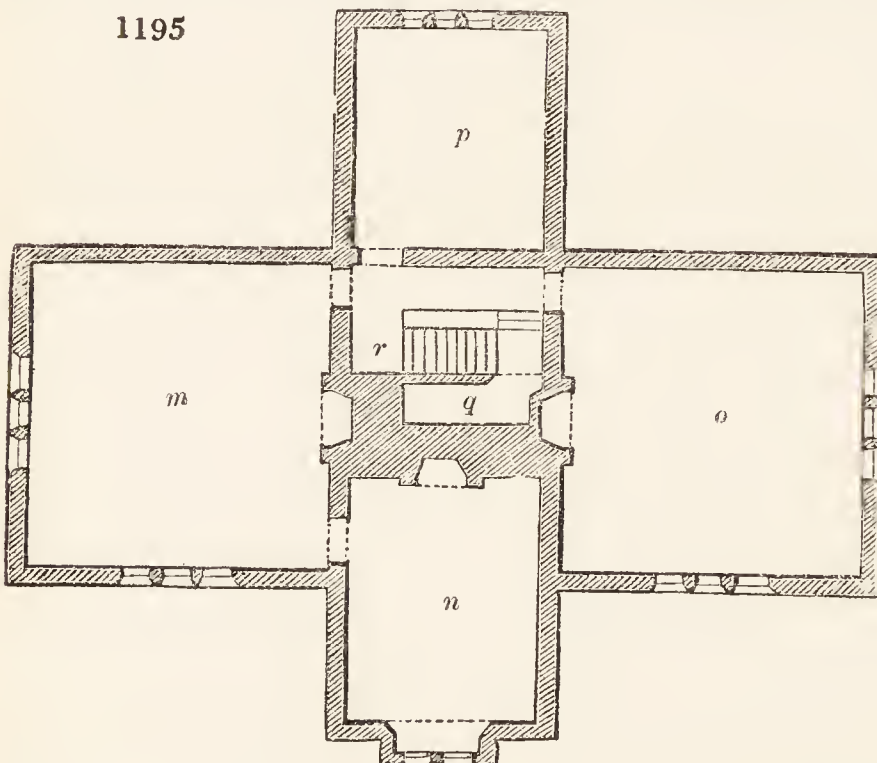
are all ornamental. There is a window in this form (see *fig. 1194.*), supported below by an ornamental bracket, which would have a good effect over a porch. These projecting windows are generally small, but they give more light than a common window of the same size. They are only proper for wooden houses, or in such parts of a house as are built of wood. The upper story in this design is supposed to be of wood and plaster, as being more picturesque, and in some places cheaper, than bricks; but in stone countries the cottage may be altogether of stone; or, both stories may be built of brick, with string-courses and copings to the gables. The chimney-stack consists of four slender separate shafts,

1194



with plain stone or brick cornices. The roof is tile or slate stone. The side walls of the chamber floor are to be five or six feet high, and the flat part of the ceiling is to be raised still higher in the roof.

1195



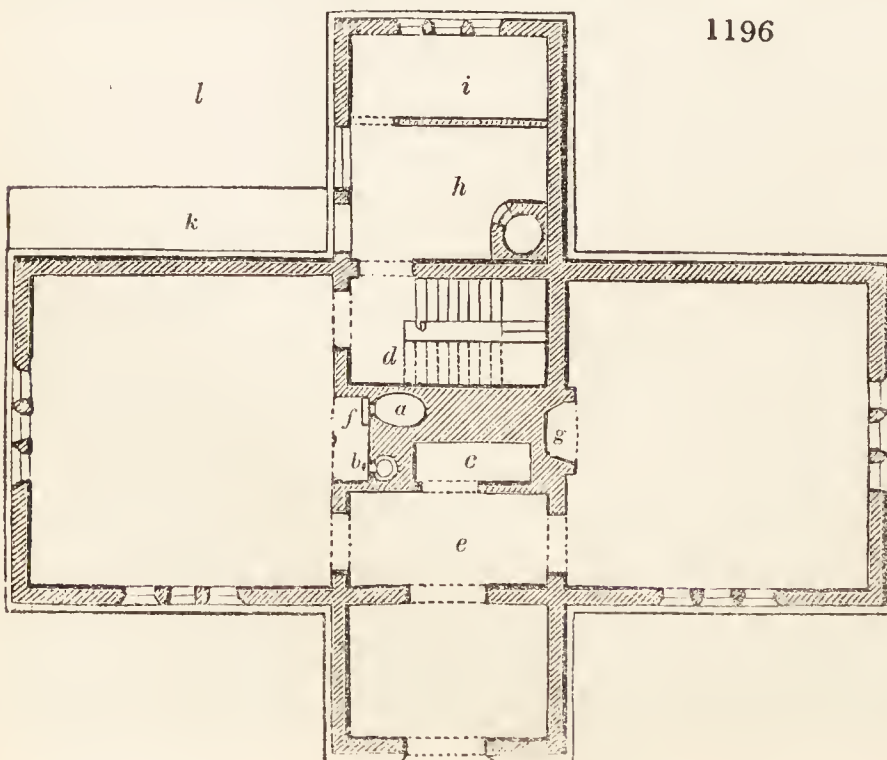
The bedrooms will thus be lofty and airy. (*Selim. Wiltshire, July, 1834.*)

8143. *A group of four cottages (figs. 1197, 1198.), represented as two, suitable for labourers with small families, comprising living-room, bedroom over, and washhouse to each. Privies are attached for the use of the two middle cottages; those of the two end ones are supposed to be detached. They may either be placed on a platform or terrace, according to the manner recommended in the *Encyclopædia of Cottage, Farm, and Villa Architecture*, or not, according to circumstances. In *fig. 1198.*, *a a* are the sitting-rooms, twelve feet by ten feet; *b b* washhouse, one eight feet by six feet, and the other nine feet by six feet; *c*, water-closet; *d d*, entrance lobbies; and *e*, staircase.*

is proposed to erect the walls of these cottages with compressed earth; which method of building is termed *pisé*, and is very suitable for cottages of this description, being a very good

8144. *Earthen walls.* It is proposed to erect the walls of these cottages with compressed earth; which method of building is termed *pisé*, and is very suitable for cottages of this description, being a very good substitute for brick, and reducing the expense of the walls one half. The chimneys must be of brick, with which the *pisé* firmly and readily unites; and, if the soil on which the cottages are to stand is not perfectly dry, the foundation must be carried above the ground-line in rough brick or stone work. I shall, however, proceed to describe the manner of executing the whole of the cottages in *pisé*, the chimneys and arches over apertures always excepted.

1196



8145. *The sort of earth* most likely to be met with is common gravel, containing a small portion of clay; and this will answer the purpose as well as any that can be found. Where clay is not found combined in sufficient quantity with the gravel in its natural state, a small portion of common clay, or of loam, which is too

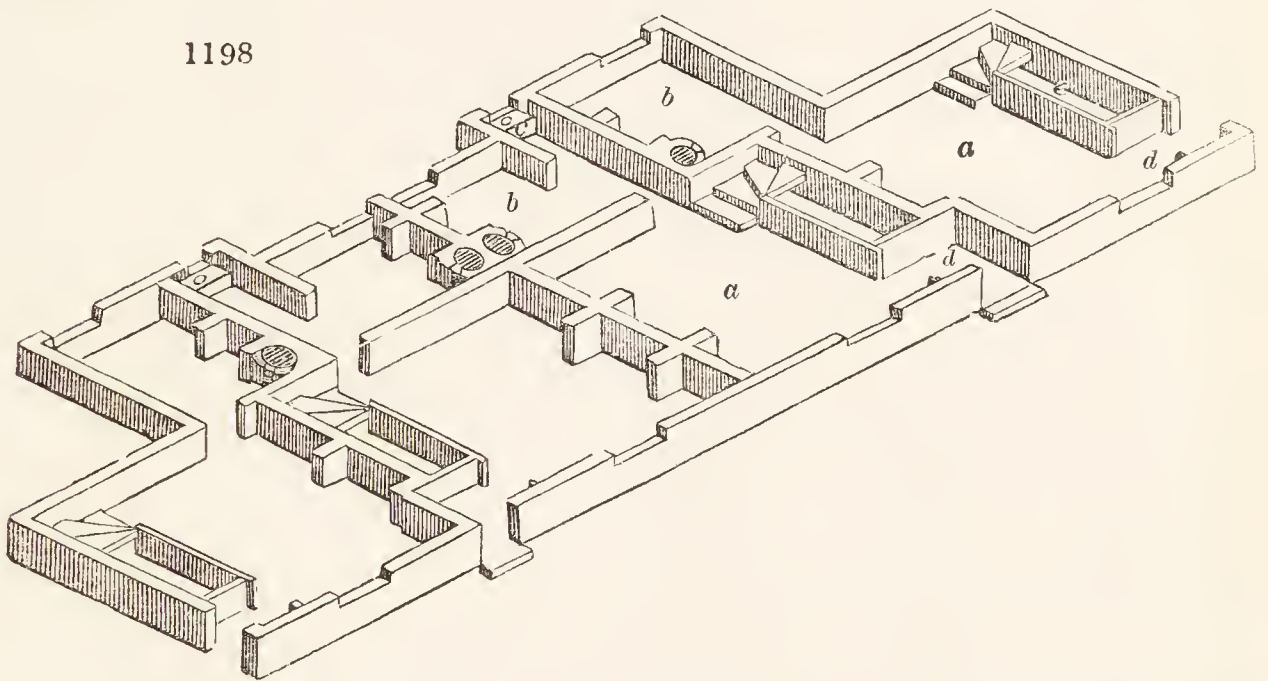
light for making bricks, may be procured, and mixed with the earth previous to its being used. On the other hand, if the clay be too strong, it will not do, but must be reduced to the proper quality by

1197



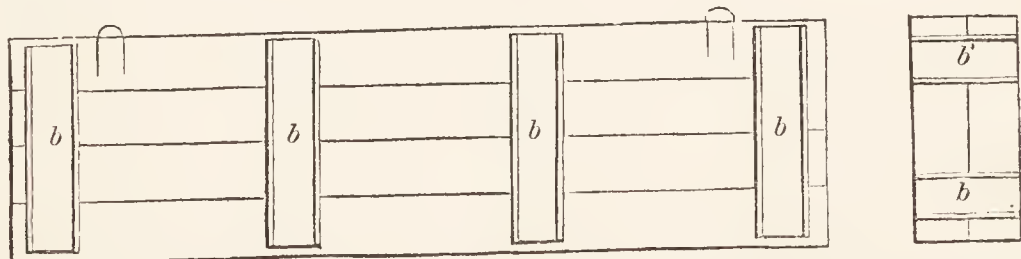
the addition of gravel or other coarse earthy rubbish; always carefully excluding all vegetable and animal substances.

1198



8146. *Mould for forming the blocks in.* For the purpose of erecting walls of this description, a mould (fig. 1199.) is required, which may be made by any country carpenter, being very simple, although consisting of several parts.

1199



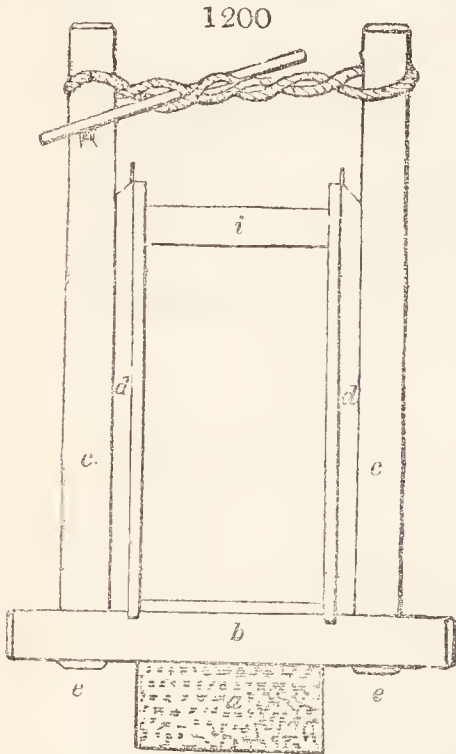
The two sides of this mould must be of one inch and a quarter of well-seasoned deal, smoothed and rabbeted, each about ten feet long and two feet nine inches wide when finished, and each having four ledges, *b*, of the same substance, nailed or screwed on the back, with iron handles to lift them by. Two heads to fit in between the sides must be made in the same way, and must be as wide as the thickness of the wall. Four bearers, mortised through at each end, receive the tenons of the upright posts. Eight upright posts stand upon these bearers, and are kept in their places by tenons at the bottom, and at the top by a line wound round each pair and twisted tight with a stick, one end of which is kept fast by being passed over a nail or peg in the post. Wall gauges, or pieces of timber cut to the width of the wall, will also be necessary to fit in between the sides of the mould, so as to prevent their coming over towards each other at top, which they will have a tendency to do during the operation. Two rammers should also be prepared, of hard heavy wood; and if formed of the root of the tree they will answer the better, being less liable to splinter off.

8147. *Mode of laying the foundation.* These things being in readiness, and the spot fixed on for the supply of earth, which should be as near to the intended building as may be convenient, the first step is to dig out the ground for the foundation in the usual manner. When trenches are opened of equal depth all round, for the outside, as well as for the partition walls, beginning at one end, fill in about six inches in depth with the ground that was taken out, and, after having trodden it well down, ram it with a heavy rough piece of timber (not with the rammers to be used in the mould), till it leaves no impression; fill in for another length; and, when the whole is covered with this first course, begin a second, and proceed in like manner till the foundation is brought up to the ground line. Large stones, or any coarse rubbish that can be conveniently procured, may be thrown into the foundation, but it should be thoroughly mixed with the earth, and, if it be very dry, a slight sprinkling of water may be

given to it, from a watering-pot, before it is put in. The wall mould will not be required at this stage of the proceedings, for the sides of the trench will form a mould; but as the edges will be somewhat broken away, the ground must be well rammed up to the foundation on both sides. Having proved the work with a level, some precaution must here be taken to prevent the damp from ascending the wall, which it would otherwise be sure to do, more or less, according to the nature of the soil. In some cases, a bed of cement, spread all over the work just above the ground line, will be sufficient; in others, a course of slates must be added, and over that another bed of cement. The chimneys should be built first, and with sound bricks and good mortar, which will allow of the earth being well rammed up to the brickwork.

8148. *Mode of fixing the mould.* The bearers are now laid on at proper distances for one length of walling, level in themselves, and with each other; the sides of the mould are then set in their places, as are also the uprights, and the end and the wall gauges are put in. The line is next passed round each pair of posts, and tightly twisted with a stick; one end of which is brought over a nail or peg in one of the posts, and kept there, by which means the whole is braced firmly together.

8149. *A section of the mould as fixed,* is seen at *fig. 1200.*; in which *a* is a portion of the wall underneath; *b*, the bearer; *c c*, posts with their tenons passing through mortises in *b*, at *e e*; *d d* are sides of the mould; and *i* is the wall gauge. The twisted line and stick are also seen at top.



8150. *Mode of forming the wall.* The turf having been pared off all round the spot whence the supply of earth for the walls is to be obtained, and as much immediately under it removed as is unfit for use, proceed to dig the same with a pickaxe, and throw it up in a heap, breaking the large lumps or clods, and drawing away the largest of the stones, which will roll to the bottom, with an iron-toothed rake. This rake, however, must not be too fine, as all stones not larger than a hen's egg may be used in the wall. Care must be taken to pick out every little bit of root, twig, or other vegetable substance that is to be found, and to throw them aside; for, if worked up in the wall, they would in a short time rot, and thereby affect its stability. If the earth be very dry, it should be wetted a little; but this must be done very sparingly and equally, and before it is put into the mould. Being thus prepared, the earth is carried to the wall in baskets, and put into the mould, at which there should be two other workmen with their rammers: one of these men gets carefully into the mould, and, spreading the earth evenly with his feet, treads it well down. A layer of about four inches in thickness being thus spread over the bottom of the mould, the men, one on each side, proceed to work it with their rammers, crossing their strokes in every direction. This layer being sufficiently rammed, others are added, and proceeded with as before, till the mould is filled within three inches of the top. The mould is then taken to pieces and fixed for the next length of walling, and one course is completed all round, including the partition walls up to the chimneys. Small wood-bricks for nailing skirting, linings, &c., to, should be put in vertically. Binders or ties of oak or other hard wood are put in

at the angles, rough from the saw, about five feet long, an inch thick, and of such a width as to allow about four inches of earth on each side of them. One of these is put in at each angle on the top of every course, the alternate ones turning different ways, and the ends consequently crossing each other. Similar ones are put in to tie the partition walls to the front and back walls.

8151. *Laying the second course.* The first course being completed, the second should be worked the reverse way: thus, if the first was from left to right, the next should be from right to left. When the walls are built up high enough for the arches to the apertures, the skew-back of the arch may be formed by chipping away the rammed earth with a pickaxe or chisel, and the arches may be turned with sound bricks in cement or good mortar, the centres being made rather stronger than usual, as well as the supports under them; and these should be left in till the wall is completed. The lintels, joists, &c., are laid in the same way as in brick walls; and these, as well as the timbers of the roof, may be laid on immediately, which is one of the many advantages which this method possesses over "cob" or mud walling.

8152. *The roof.* The roof is intended to be slated, and furnished with eaves, trough, &c.; and the outer walls stuccoed, or a still cheaper coating may be given of roughcast.

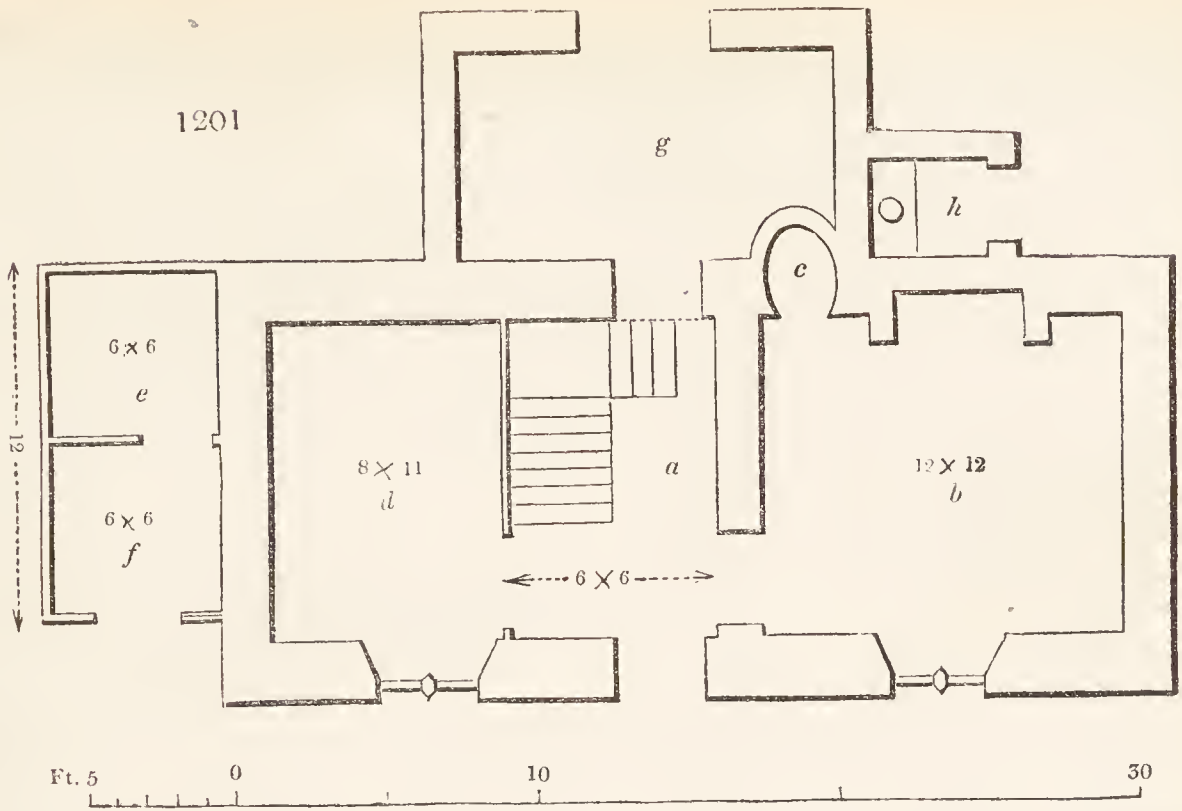
8153. *Finishing.* The holes in the walls left by the bearers of the mould may remain open for a short time, which will occasion the walls to dry the quicker; and the plastering should not be laid on till a few weeks after they are finished, or the sweat of the walls will cast it off again. The roof, however, should be covered in, and eaves-troughs fixed as soon as possible. When the walls are ready for plastering, they should be covered all over with small holes, picked in with the sharp point of a hammer, or some such instrument, which will give a hold to the plastering; the loose dirt being brushed away with a stiff brush, and the walls then slightly sprinkled with water. The plastering is done in the usual way of rendering on brickwork; which, however, requires rather more wetting than *pisé*.

8154. *General remarks.* This will be found an economical, easy, and expeditious manner of erecting cottages, farm or other ordinary buildings, and, if properly executed and protected, will soon become as hard as stone, affording the comforts and convenience of a brick building, at nearly half less expense, and being vastly superior to those miserable hovels, put together with mud and sticks, which still disgrace many parts of the country as human habitations.

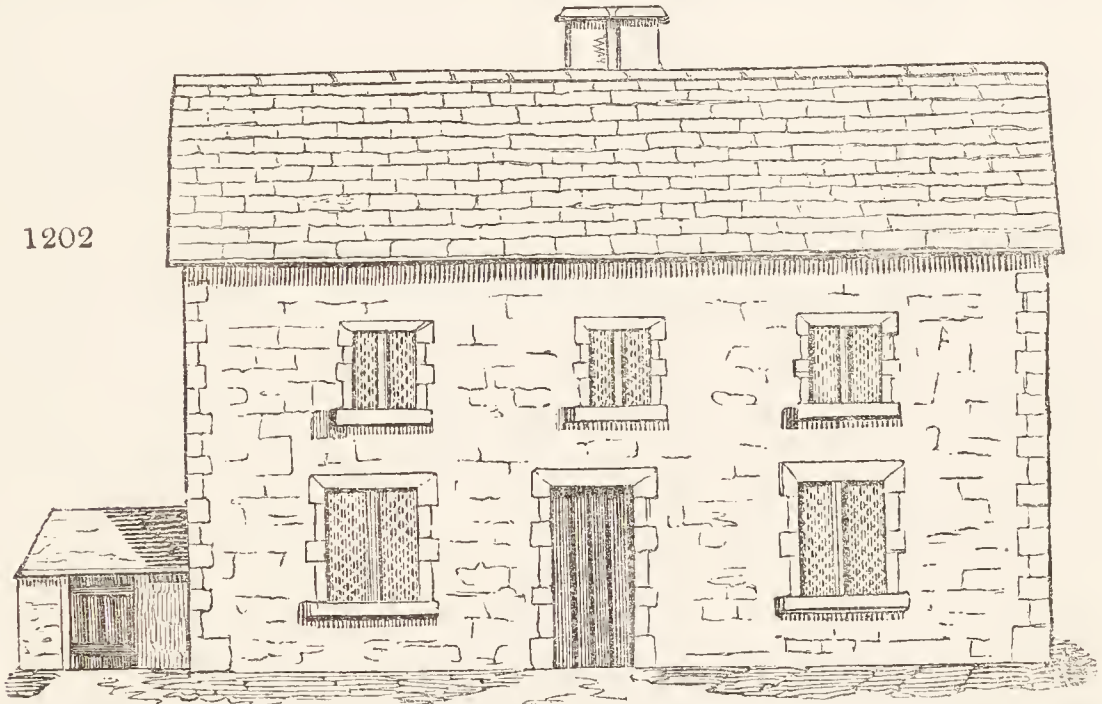
8155. *Estimate.* The expense of erecting the four cottages represented in *figs. 1197.* and *1198.* according to the above plan, and finished according to the usual cottage style, will probably amount to the sum of 250*l.*, supposing the supply of earth to be conveniently placed, and of tolerably good quality.

8156. *The Gloucestershire agricultural labourer's cottage* is represented in *figs. 1201,* *1202,* and *1203.* *Fig. 1201.* shows an entrance, *a*, with a staircase down to the cellars, and up to the bedrooms; a living-room or kitchen, *b*, with an oven, *c*; a back kitchen or room for washing kitchen utensils, *d*; a covered pigsty, *e*; a yard to the pigsty, *f*; a shed for fuel, *g*; and the privy, *h*. There are bedrooms over *b* and *d*; and cellars under them. The lobby, and the space under the ascending stairs, are sufficiently large to admit of being used as a place for the family to sit in, in the summer season, when the heat of the kitchen might render it uncomfortable. *Fig. 1202.* is the front elevation of this cottage, and *fig. 1203.* the back elevation. These cottages, of which a number have been recently built on Mr. Lawrence's estate, by his brother, Charles Lawrence, Esq., who acts as agent for him, have each a quarter of an acre of good land attached as a garden; and, though they are well worth 5*l.* or 6*l.* a year, they are benevolently let by Mr. Lawrence for 52*s.* each. In order to teach labourers how to cultivate their gardens, Mr. Charles Lawrence has composed one of the best tracts on the subject of cottage gardens for country labourers, which has yet appeared, and has distributed it among them. It is entitled *Practical Directions for the Cultivation and General Management of Cottage Gardens,* &c.; and we would strongly recommend it to all who wish to teach country labourers how to make the most of their gardens.

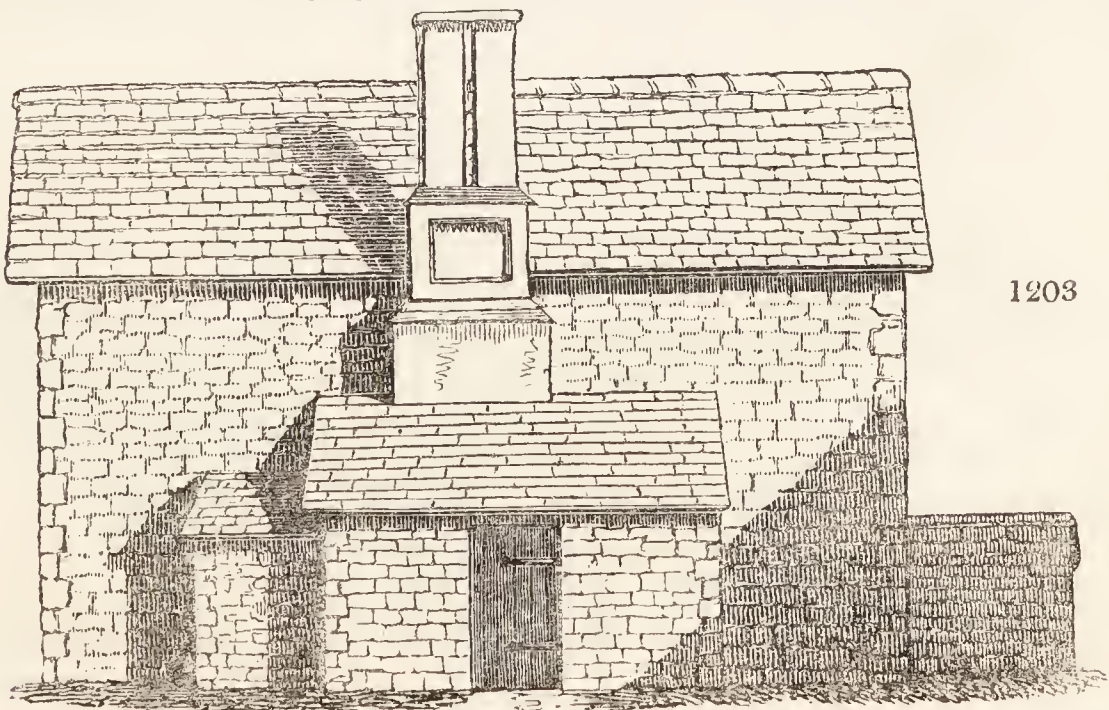
8157.—2919. *Farm buildings.* The greatest improvement which has been made in these, since the



publication of our second edition, is by W. M. Mackenzie, Esq., an architect of Perth. A number of minor improvements, by different Scotch architects, will be found delineated in that part of our *Archit.*



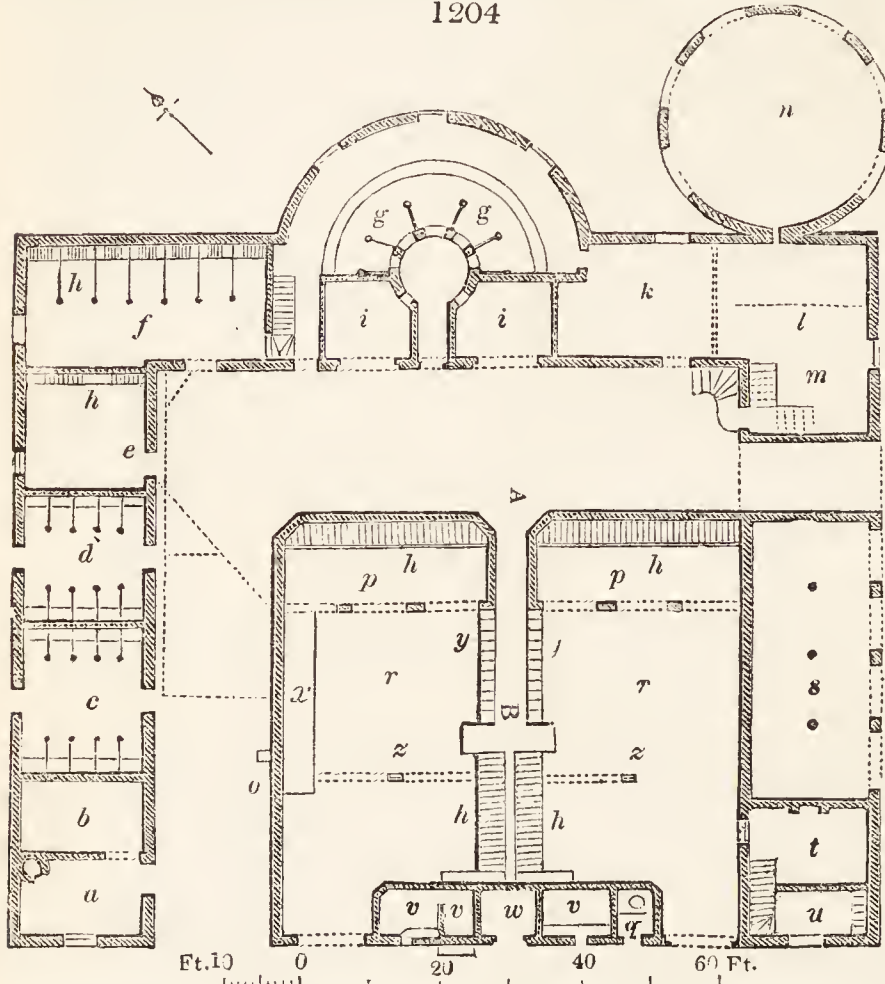
tectural Encyclopædia which treats of farm-houses and farmeries; but those of Mr. Mackenzie far surpass all the others. In the *Encyclopædia of Architecture*, p. 537., will be found a design for a farm of



six ploughs, in which all Mr. Mackenzie's improvements are introduced, and described in detail; and in our *Architectural Magazine* (vol. i.) will be found another design by Mr. Mackenzie for a three-plough farmery; which, embodying all the improvements alluded to, and being of very general application, we shall here quote in the first place, and subsequently give two other designs, one by J. Milne, Esq., an Edinburgh architect, and the other by J. Blackadder, Esq., a land-surveyor of Berwickshire; both eminent professional men.

8158. *Design for a three-plough farmery, by Mr. Mackenzie of Perth.* Fig. 1204. is a ground plan; fig. 1205. an isometrical view; and fig. 1206., a vertical profile. This three-plough farmery is understood to be built upon level ground;

1204



- a, Boiling-house.
- b, Potato-house.
- c, Cow-byre.
- d, Calf-byre.
- e, Saddle-horse stable, and double stall enclosed for a mare and foal.
- f, Common farm stable, with hay and straw-chamber above.
- g, Feeding-byre, with straw-chambers above.
- h, Racks for hay or straw.
- i, Turnip-sheds: straw-chambers over.
- k, Straw-house with upper floor.
- l, Threshing-machinery.
- m, Clean corn-room, unthreshed corn above.
- n, Horse-shed for threshing-machines.
- o, Pump for liquid manure tank.
- p, Cattle-sheds.
- q, Privy.
- r, Straw-yards.
- s, Cart-sheds, with granary above, carried over the carriage entrance to the farmery, and communicating with the clean corn-room.
- t, Boothy for men servants, with beds in the upper-floor extending over the poultry-house.
- u, Poultry-house.
- v, Piggeries.
- w, Water-house.
- x, Tank for liquid manure.
- y, Turnip-boxes.
- z, Gratings over the drains leading to the liquid manure tank, to prevent the straw from the yard from choking up the drains.

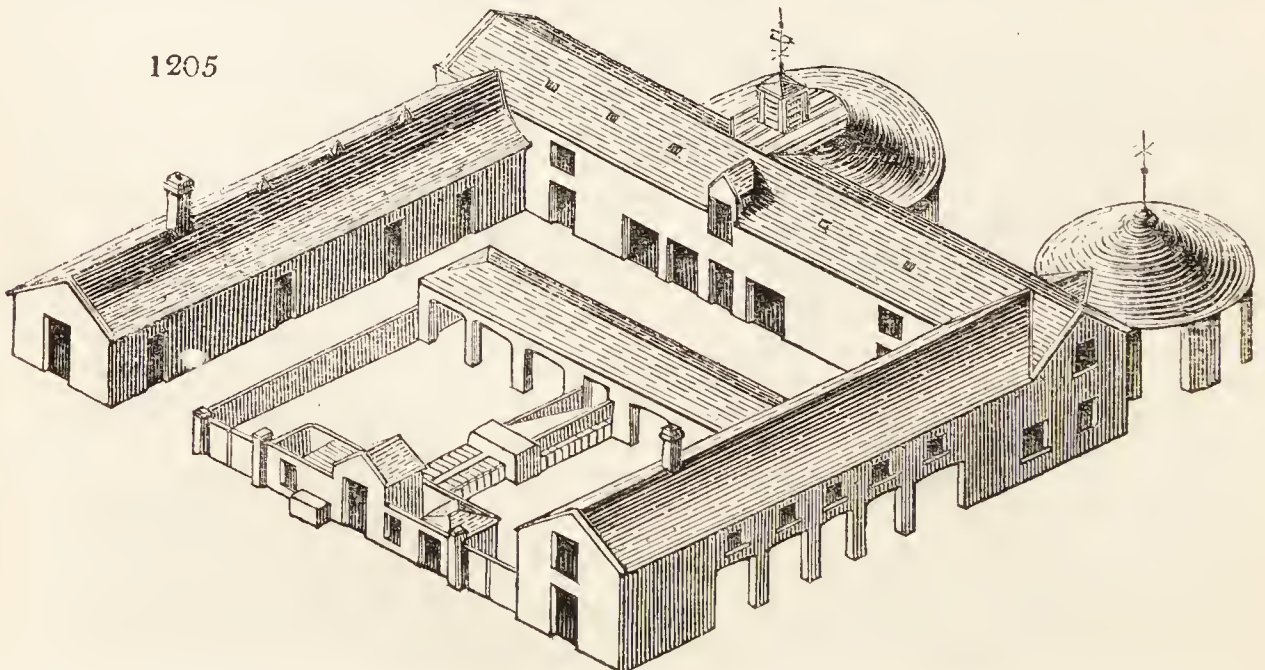
occupy a side of the square apart from the offices allotted for the cattle, and the other apartments connected with them; and, as the corn-room can be locked up the moment the operation of threshing is finished, no opportunity is left for the grain being pilfered or injured. The granary in this situation has not only the advantage of the ventilators in the side walls, but it has also the benefit of the free air from the open cart-shed under it, which acts upon the grain through the joints of the floor. The cart-shed

to be built upon level ground; with the straw-yard cut out hollow in the centre of a basin figure; that being the best form for retaining the moisture among the manure. In fixing the position of the different ranges of the buildings, the highest are put down to front the north and east, as best suiting the purposes to which those parts of the farmery are to be applied; and at the same time adding to the comfort of the cattle in the sheds and straw-yards, by sheltering them in the directions which are generally the coldest.

8159. *The byres (c, d),* which are low buildings on the west, and the pigsties (v), which are on the south, do not shade the straw-yard and cattle-sheds, but admit the rays of the sun to all parts of them. The farmhouse is supposed to be situated on the south-west of the farmery, with the kitchen court adjacent to the cow-byre, calf-yard, &c.; thus keeping the offices which are managed by the house servants in one division, and those under the management of the farm servants in the other division of the establishment.

8160. *The threshing machinery (l),* being placed in a corner of the square, discharges the threshed corn into the clean corn-room (m), in the direction of the granary, which occupies the upper story of that side of the square; and the straw is thrown from it into the straw-house, which is in the direction of the straw-chambers, over the feeding-byre, stables, &c., on the other side of the square. The clean corn-room thus communicates with the granary, which extends from this point over the cart-shed. In this way the clean corn-room and granary

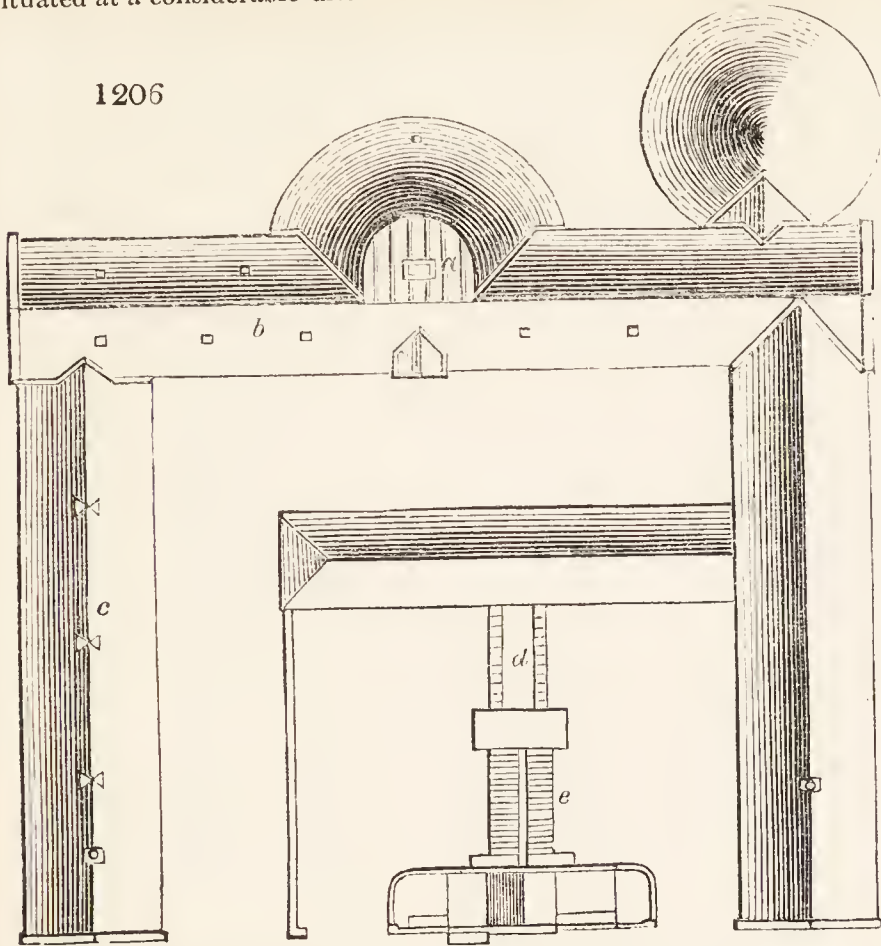
1205



under the granary, besides being beneficial to it for air, is convenient, particularly where a farm is situated at a considerable distance from a market-town : or in the winter

season, when the carts require to be loaded on the evening preceding the market-day ; as it can be done before yoking (putting the horses in), and without moving the carts from under their cover, by means of the trap-door in the centre passage of the granary : which passage must at all times be kept clear from grain. In the straw-house, a trap-door is placed over the straw-rack ; and, when the lower part of the house is packed full, this trap-door can be shut, and the straw carried along the upper floor to the straw-chambers over the stable and feeding-byre. These apartments will contain the straw of two ricks, which will enable the farmer to keep different kinds of straw under cover, and in separate divisions. A door is placed opposite the passage which extends along the centre of the straw-yard for taking out straw for the cattle-sheds, cow-byres, &c., if at any time required ; but in general these are supplied from the low straw-house. The threshing-machine is one of six horse-power, and is impelled by horses ; but where water can be had, it is a great improvement, as the men may be employed threshing, while the horses are resting : this is advantageous in a still greater

1206



a, Platform forming the upper part of the roof of the feeding-shed.
 b, Ventilators to the stables.
 c, Ventilators to the byres.
 d, Inclined plane between turnip boxes.
 e, Racks for hay or corn.

degree at certain times, when the field operations exhaust all the horse power.

8161. *The circular byre (g)*, which will contain ten head of cattle, is by far the most commodious and convenient arrangement ; and, for a farm double this extent, the same form may be introduced, with equal advantage, by carrying the stalls wholly round the circle where the sheds are. The figure of the stalls, being broad behind, gives more space for the cattle when lying down ; and, as a greater quantity of litter is requisite, more manure, of course, will be made : at the same time it admits from behind a more abundant supply of fresh air, and has also the advantage of one large ventilator in the centre of the circle serving the whole. The ten head of cattle are put up in double stalls in pairs ; they are bound up one on each side of the partition, which is made high enough to prevent the horned cattle from touching one another ; at the same time keeping the heads of each pair at such a distance apart, as to prevent them from injuring each other, or eating each other's turnips. The bends, or cow-ties, are fixed to upright iron rods about three quarters of an inch in diameter, which are screwed together through the partition. The lower part of the windows in the back wall of the byre are filled with luffer-boarding, which can be opened to any degree for admitting air, or shut altogether at pleasure. The feeding-ports, or openings which surround the feeding-chambers, have small doors hung with pulleys, lines, and weights, similar to those of a common window, which, by moving upwards, do not interfere with, or occupy, any part of the chamber. The wall at the heads of the cattle surrounding the feeding-chamber is built to the full height of the joists ; which keeps the turnip barrow out of the view of the cattle, and does not disturb the one division of them, while the man is in the act of feeding the other. This is important, as the quieter cattle are kept the better, quietness being, no doubt, essential to quick fattening.

8162. *A commodious straw-chamber* is obtained over the byre, in a connected range with the straw or hay chamber over the stable : the roof, which is of considerable width, serving the double purpose of covering the feeding-byre, and of containing a very large quantity of straw immediately over it. Racks are placed over the several stalls, which are filled from the straw-chamber above. By this arrangement, the cattle have it in their power to eat straw and turnips alternately, if inclined. The access to the straw-chambers over the byre and stables is by a stair, which is common to both ; and upon the plate (first landing-place) of this stair is placed a door, which divides the stable from the feeding-byre ; the upper flight of the stair is understood to be a hanging one, having a useful space under it for holding the byre implements. By the whole arrangement much labour in feeding and attending the cattle will be saved.

8163. *The stabling (e, f)* consists of ten stalls, three of which are separated from the general farm stable, but are so situated as to admit of the racks being supplied from the general straw or hay chamber over the common farm stable. They are understood to have two sets of racks ; the upper are for hay or straw, and the under one for grass. Although the under racks appear the most natural for the horses to eat from, it is found that they do not eat the straw or hay so clean out of them, as they do out of the upper racks ; but these under racks are the most convenient for the grass, as it should always be put in from the stall below, without passing through the hay-chamber ; being, in its damp state, very hurtful to the wood floor above. Part of the three-stall stable is set apart for a mare and foal.

8164. *The turnip-shed (i)*, adjoining the feeding-byre, is also conveniently situated for supplying the cattle in the straw-yard ; and, as it is not required for turnips in summer, it may be used for and serve the double purpose of a turnip-house and a grass-house.

8165. *Ventilators.* The cow-byres have ventilators placed over each line of heads ; these cross the ridge, and are formed of lead of a triangular figure ; the sill piece being overlapped by the sides far enough to prevent the rain from getting in. (See c in fig. 1206.)

8166. *The calf-house and ward*, and the cow-byres (c, d), which fall under the class of offices more immediately connected with the farm-house, have doors facing the kitchen-court, which makes the access to them convenient and clean. The opposite doors are used for driving out the cattle, and for wheeling the manure into the straw-yard. The causewayed court, in front of the byres, besides being convenient for carting in the turnips, affords space for the cows to move about in, or to stand in for a short time ; and, as the cattle always dung when they are driven out, by allowing them to remain for a few minutes in this passage or court, the manure, that might otherwise be wasted on the roads, is preserved, and thrown into the straw-yard.

8167. *The several drains* leading from the byres, stables, and straw-yard, have such declivities as are sufficient to discharge the liquid manure into the tank, which is constructed on one side of the straw-yard in a central situation for the byres, stables, &c. It is thirty feet long, three feet broad, and seven feet deep; and, if the nature of the soil be porous, it should be plastered with Roman cement, to prevent the thin liquid manure from escaping. Being of this long and narrow figure, the tank can easily be covered with flagstones, which are much cheaper than arching, and take up less space. The drains should have holes fitted with cast-iron plugs, placed about fifteen feet apart; so that at these openings a jointed rod fifteen feet long could be put into the drain, with a hoe, or a piece of plate iron the shape of the drain, fixed to the one end of it. By these means the drains may be cleaned without breaking up any part of the causeway; but, if the drains are properly constructed, they will not require cleaning for several years. They should have a fall, towards the tank, of at least four inches to the ten feet, and be nine inches wide, six inches deep at the sides, and nine inches in the centre. By having this kind of triangular bottom, the smallest quantity makes a current, and forces everything along with it. The drains through the straw-yard should have openings with grates (x x) over them, situated in the lowest part of the straw-yard, to draw off the surplus water after heavy falls of rain or snow. When these drains are not required, the grates may be easily covered over with dung; and if, at any time, the manure is found too dry, movable spouts may be attached to the pump which is placed in the tank, by which means the liquid manure can be regularly spread over the whole straw-yard. A waste drain extends from the tank to an open ditch near the buildings; by which means, the liquid manure in the tank, if neglected, is carried off when it rises to that level, and is thus prevented from injuring the drains.

8168. *The cattle-sheds (p)*, from their situation, face the south, which is of great advantage to the cattle, though often overlooked in laying out farm buildings, and they are divided in the centre by a passage adjoining the turnip-shed, and opposite the straw-house. This passage rises like an inclined plane four feet from A to B: the sides or parapets may be of wood, two inches thick (which forms a back to the turnip boxes), and be four feet in height, forming a fence to both yards. All the manure from the feeding-byre and stable is wheeled into the straw-yards by this passage: which, from its central situation, admits of the stable dung being equally distributed through both yards, and this by the rising passage can be done without opening a door, which prevents the one class of cattle from intermingling with the other, or getting out. Straw-racks (h h h h) are placed in the sheds; but, by also having them in the centre of the yard, and connected with this passage, they can be conveniently filled, and the cattle are induced to divide, which mixes the dung more generally through the yards.

8169. *The piggeries (v)*, from their situation, may be conveniently supplied from the kitchen or boiling-house, and are in both yards. Pigs are very beneficial to the manure, from their turning it over, and mixing it; they also eat up any particles of corn among the horses' dung that may not have been digested. One small enclosure is provided with a trough for feeding young pigs, and they are thus protected from the cattle while eating; but they have no house or sty, that they may be induced to go out among the cattle, and to lie down about the sheds. By this arrangement, they have healthy exercise, and are enabled at the same time to provide a part of their food, and to be beneficial to the manure in both yards. Another sty is provided for putting up a pair to feed.

8170. *The gates to the straw-yard* may either be of the common form, or be hung, like sash windows, with stout ropes, pulleys, and weights. This last is perhaps the best plan, as it secures them from the risk of damage when the dung is being carted out of the yard; and also enables them to be raised as the straw in the yard rises.

8171. *The cistern-house (w)* is of such a height that pipes may be taken from it to the dwelling-house, boiling-house, calf-ward, &c. It may be either supplied from a spring, if one is to be found in the neighbourhood; or a well may be dug, and a pump placed within the cistern-house. A water-trough is placed in the division wall between the straw-yards; and a ball-cock is fixed in the centre of the said trough, and shut in by boarding, overlapped by the upper part of the wall, which thus protects it from injury by the cattle. By this self-acting supply, the cattle at all times have the command of water, and none of it is wasted: if supplied from a spring, no attention is necessary, as the supply may be regulated by having a ball-cock in the cistern. Two troughs are placed on the outside, for the horses and the milch cows, and are also supplied with ball-cocks. The roof water, in the inside of the court, is carried round with eave-spouts, and with rainwater pipes at the south extremities, leading it into drains. It is a material object to carry off the roof water, without allowing its admixture with the manure in the courts.

8172. <i>Estimate.</i> — Masonwork, excavations, and paving	-	-	-	-	£	s.	d.
Carpenter's, glazier's, and smith's work	-	-	-	-	470	0	0
Slater's and plumber's work	-	-	-	-	145	0	0
Plaster work	-	-	-	-	5	0	0
					<hr/>		
					£	993	0 0

The above estimate is made out upon the supposition that stone may be got for the working, at a distance not exceeding one mile from the building; and that the land carriage of the timber (which is all foreign) and of the lime should not exceed from five to ten miles, and that of the slates from ten to fifteen miles.

8173. *Design for a set of farming offices, and farm-house, for a low-country farm, employing two ploughs, by Mr. Milne of Edinburgh.* In the ground plan of the farm-house (fig. 1210.), there are an entrance lobby, a; staircase and stairs to attics, b; passage, c; kitchen, d; kitchen and dairy scullery, e; family bedroom, f; dining-room, g; bedroom, h; farmer's room, i; coal-house, k; back entrance, l; parlour, m; laundry and maid-servant's room, n; scalding-room, o; dairy or milk-house, p; entrance to the dairy, &c., q. The ground-plan of the farmery (fig. 1209.) consists of the calf-house, a; yard for airing cows, b; dung pit and liquid manure tank, c; seed potato-house with hay-chamber over, d; stable for five horses, e; tool-house, f; cart-shed, g; straw-barn, h; house for threshing-machine, i; feeding-byre for eight fattening cattle, k; byre for ten milch cows, l; cleaning passages, m m; root and potato house, n; boiling-house, o; feeding-house, p; feeding-place for pigs, q; pigs' sleeping place, r; privy, s; pump from the liquid manure tank, in the centre of the dung-yard, t. The double dotted lines indicate the various drains leading to the liquid manure tank.

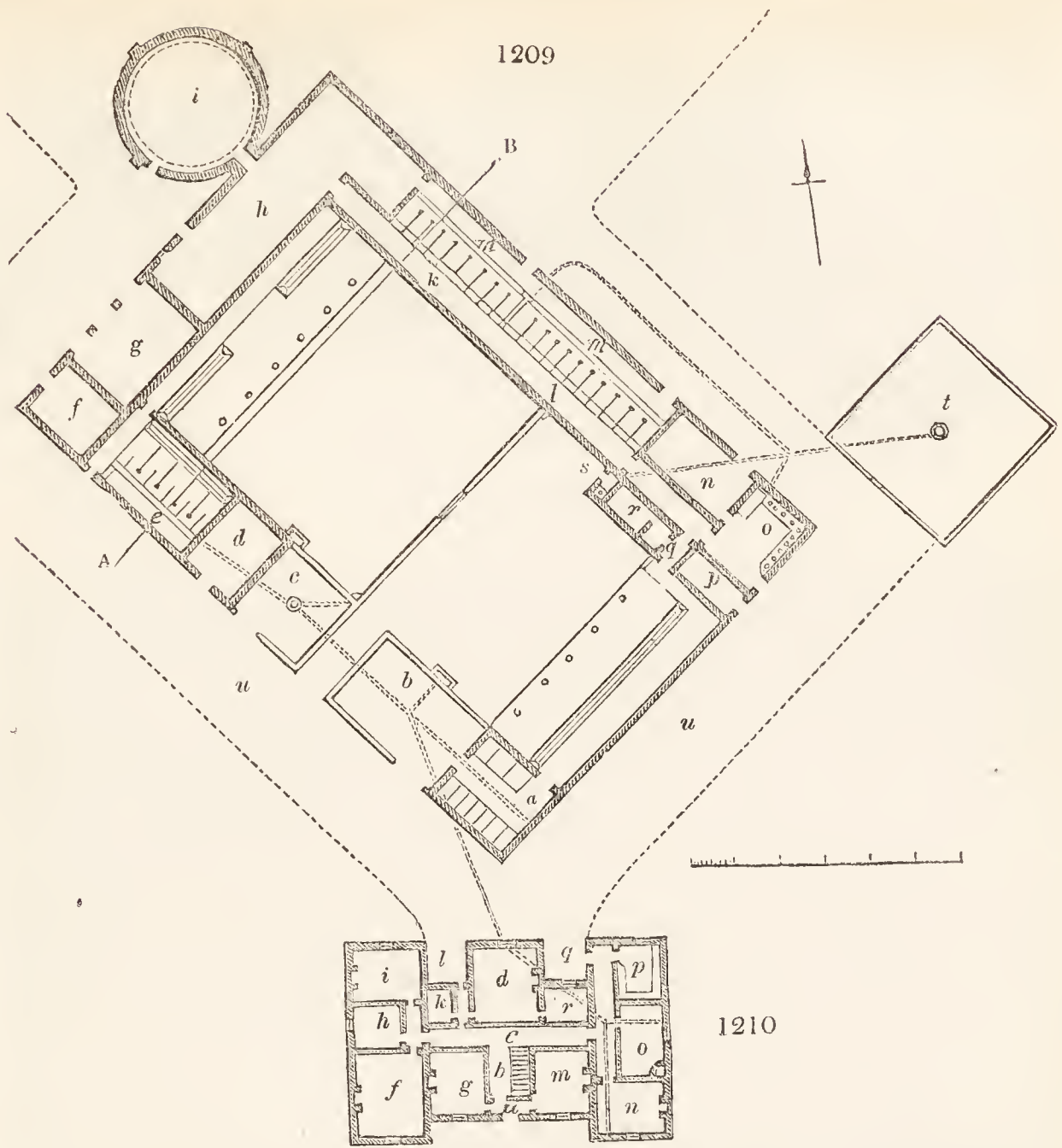
Fig. 1207. represents a section through the farmery offices on the line A B.

Fig. 1208. is a geometrical elevation of the front of the farm-house.

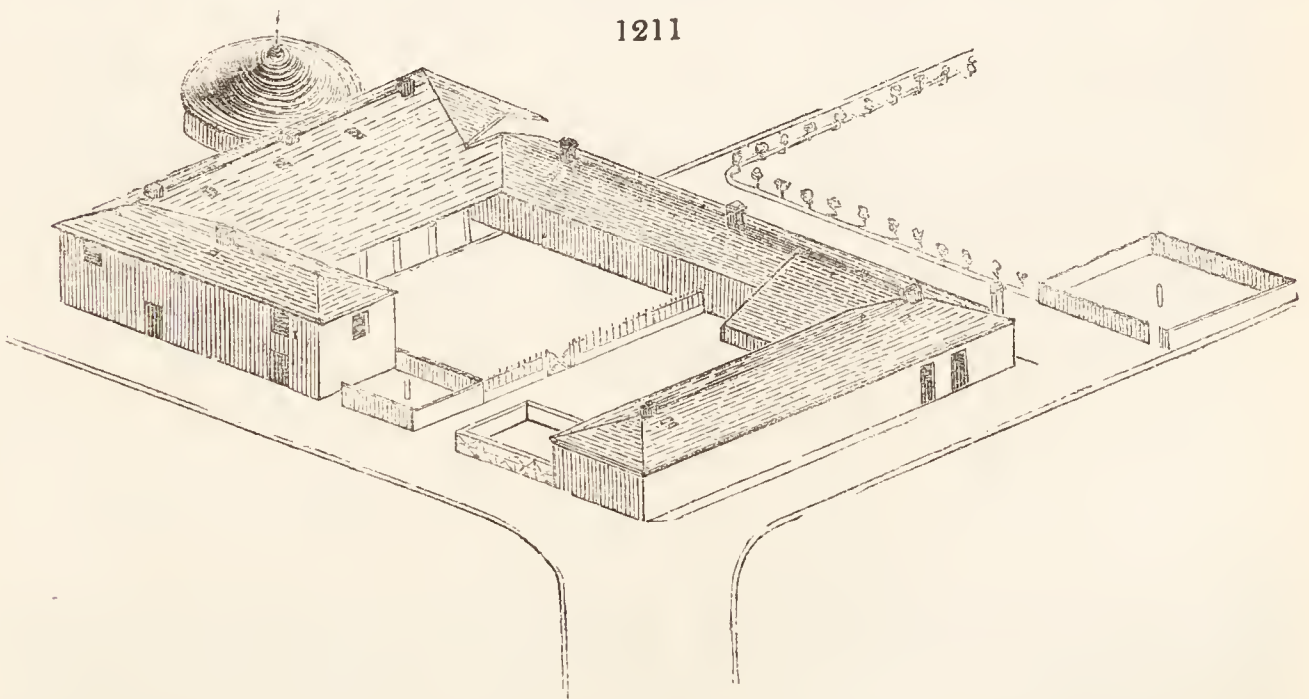


Fig. 1211. is an isometrical view of the farmery.

8174. *Remarks on the arrangement of the farmery.* In designing a farmery, the object in view is to secure that disposition of the buildings which shall be the most convenient, at the least expence; and, in order to attain this object, the arrangement of the various apartments in this plan is very different from that which is usually adopted. Economy in the number or strength of the servants, together with such a plan as shall prevent the provcnder from being blown about by every gust of wind, and also pre-



vent the necessity of dragging it over urinous pools of water and wreaths of snow, and which offers a number of courts for wintering cattle of different ages, is alike profitable for the proprietor and farmer. While making a design, however, without reference to any particular farm, a considerable difficulty presents itself. By assuming only that so many ploughs are to be employed, no adequate idea can be formed of the site of the buildings; which, were it known, might lead to a difference of construction. Even a seemingly untoward piece of ground can, in the hands of a skilful architect, be turned to advantage for



this or for any other purpose. The nature of the soil, too, its local situation, and capability for and extent of pasturage, would determine the number of cattle to be housed, &c., none of which data can be given on this occasion. But, assuming that a two-plough farm is capable of raising every year 67 imperial quarters of wheat, and of oats 280, of barley 67, and of peas 24 quarters; and that, collectively, these would yield about 7000 stones (of 16 lbs. each) of straw: then, for making butter and cheese for the market, there could be kept ten milch cows, five one year old cattle, five two years old, and seven three years old,

to be kept through the winter, and fattened for sale in the spring; and accommodation for this number of cattle is provided in the design, *fig. 121C*.

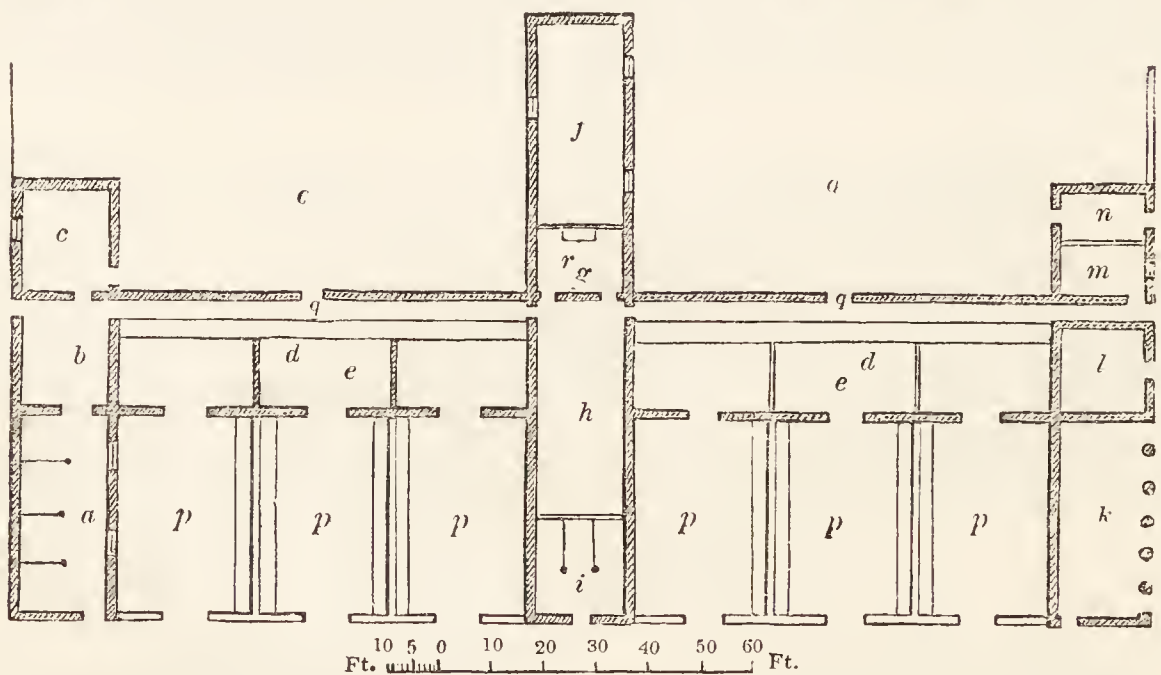
8175. <i>Estimate for the farmery.</i> —	Masonry of the offices	- - - -	£	s.	d.
	Carpentry	- - - -	-	93	19 4
	Covering the roofs, slating, and furnishing lead	- - - -	-	83	4 9
	Amount for the offices	- - - -	£	349	7 3

8176. *Farm-house.* The relative situation of the house to the offices claims particular attention. It is here placed, so that the farmer can see two sides of the farm-yard at once, and that at the greatest distance possible, without requiring an extensive paved court between it and the buildings. Where the operations of a dairy are carried on within the house, it is better to make it one story high than two: the heated vapours which ascend from the process of butter and cheese making, combined with the peculiar gases which are evolved from the apartments where such operations are carried on, render an upper story uncomfortable; and this evil is sufficiently great to counterbalance the extra expense of a little more roofing.

8177. <i>Estimate of farm-house, &c.</i> —	Masonry	- - - -	£	s.	d.
	Carpenters' and joiners' work	- - - -	-	87	18 9
	Covering of roof	- - - -	-	35	15 6
	Amount for the house	- - - -	207	5	10½
	Add amount for the offices	- - - -	349	7	3
	The whole amount	- - - -	£	556	13 1½

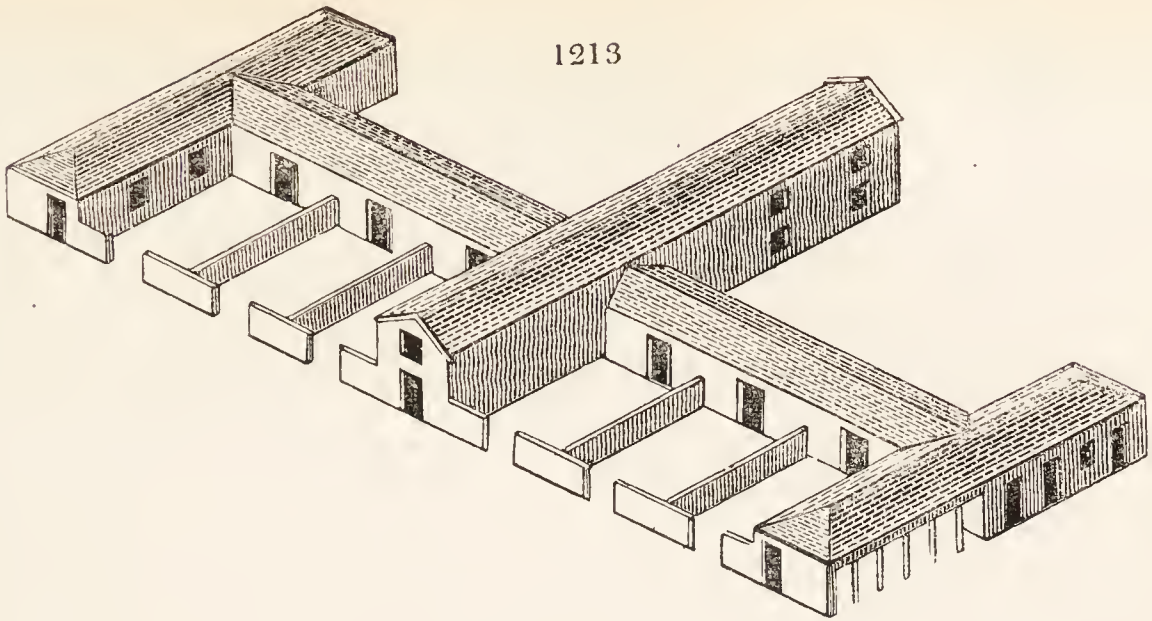
8178. *General remarks.* The practice of tossing the dung out of the byres (cow and cattle houses) through a hole in the wall should be discontinued; as by this practice the house is kept in a most un-healthy state, the groop (gutter) and walls are abominably bespattered, and a current of offensive gas is continually evolved from the putrid mass at the door. It is a mistaken notion that cattle will thrive equally well in a tainted atmosphere as in pure air. The best practice is to drag the fulzie (filth) to a urinal pit at some distance, and occasionally to pump the liquid manure upon it. A horse-course is shown for the threshing machine, which almost requires an apology, as steam power is now very generally used; and the farmers in East Lothian are even said to be improving their high-pressure engines, by condensing the steam, and not using an air-pump. A valve is attached to the bottom of the condenser that opens to the outside; the effect of which is, that, when a blast of steam gets into the condenser, it pushes open the valve, thrusting out by it any air and water which had collected in the condenser during the previous stroke of the machine. As soon as the air and water have been pushed out, the jet valve is opened, the steam condensed, and the stroke effected, when the blast of steam again forces the air and water out of the condenser. The valve at the bottom shuts close by the pressure of the atmosphere, as soon as the condensation of the steam within begins to take place. By this cheap contrivance seven pounds per inch of the working piston is said to be gained. Skylights in stables and byres are preferable to windows, which are liable to be broken by the farm servants; in which cases currents of cold air enter, till they are at length closed with an old hat, or some other opaque material, by which the air and light are both shut out at the same time. When the currents of air are not stopped, they bring diseases upon the horse, which are often difficult, if not impossible, to cure; and, by excluding the light, his vision is weakened when he is taken out, and, if he is predisposed to "moon blindness," the disease is called forth. Many are the evils to which the horse is liable by subjecting him to sudden changes of light and temperature; but, by placing the windows of the stable in the roof, and by thoroughly ventilating the whole building, he has some chance of escaping from them. Indeed ventilation is essential, not only for the health of the cattle, but for the preservation of the building; yet, strange it is, that it is seldom if ever attended to. From the humid air in stables and byres, fungi may be frequently seen upon the rafters and other timbers of buildings, which are also often attacked by dry rot.

8179. *Plan, elevation, description, and estimate of a farmery, by Mr. Blackadder of Berwickshire.* In the ground plan (*fig. 1212*), *a* is the work-horse stable, measuring eighteen feet by forty feet; *b*, stable



incidental, places for keeping stable utensils; *c*, storehouse for turnips, &c.; *d*, straw-racks; *e*, shelter sheds, with open courts in front; *f*, is the dressing-barn (over which is the threshing machine), measuring eighteen feet by forty feet; *g*, chaff-house; *h*, straw-house, with granary above, eighteen feet by forty feet; *i*, riding-stable, with granary over it; *k*, cart-shed, eighteen feet by forty feet; *l*, wheelwright's shop and storehouse; *m*, piggery; *n*, hen-house; *o*, stack-yards; *p*, six open courts in front of the sheds, each measuring twenty-five feet by forty feet; *q*, passage through which to pass to serve the racks with straw; *r*, situation of the fanners. *Fig. 1213* is an isometrical view of the farmery.

1213



8180. *Specifications.* The height of the side walls for the barn and straw-house to be fourteen feet, and the side walls of the other buildings to be nine feet. The dressing-barn to have seven feet, and the straw-house and riding-stable ten feet of head room. The shelter sheds to be joisted and covered with loose boards, and used as an additional straw-house. The back of the racks along the open passage to be close boarded up six feet in height, and the front laid with horizontal spars ten inches apart: the bottom of these racks to be laid with cross spars, sloping from the back down to the front, so as to send forward the straw as the rack is cleared out by the cattle; and this bottom to be laid at such a height as will allow the pigs a free range throughout the whole, and also to have liberty to go into each courtain (stall). The water to be had from the mill-head, or from pumps or wells, put down in one or two different places, according to the local situation.

8181. *The site of the farm-house* to be at any convenient distance in front of the farm-stead, allowing at least a complete cart road all round the latter; and the cottages that may be required, to be placed on the right and left side of the road opposite the cart-shed and work-horse stable. Each of these cottages to lodge two families only, and to have a pig-house and garden behind it: this will add much to the comfort of the cottager, and encourage a desire to cleanliness.

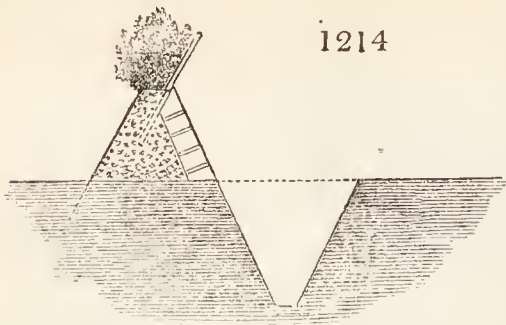
8182. *General estimate.* The walls of these buildings are supposed to be erected of stone, and the following are the estimates for Berwickshire:—

	Yds.	£	s.	d.
8183. <i>Rubblework.</i> — Barn and straw-house	537	at 4s.	107	8 0
Stable	269	at 4s.	53	16 0
Cart-shed	269	at 4s.	53	16 0
Shelter-sheds	355	at 4s.	71	0 0
Courtain walls	320	at 4s.	64	0 0
Total of the rubblework			350	0 0
8184. <i>Hewer's (stonecutter's) work.</i> — 540 feet, at 6d.			13	0 0
8185. <i>Roofing.</i> — Barn and straw-house	440	at 5s.	110	0 0
Stable	291	at 5s.	72	15 0
Cart-shed	291	at 5s.	72	15 0
Shelter-sheds	582	at 5s.	145	10 0
Racks and feeding-troughs in the shelter-sheds			40	0 0
Barn floors	188	at 5s.	45	0 0
Granary floor	109	at 5s.	27	5 0
Stalls in the stables	42	at 3s. 6d.	7	7 0
Racks and mangers	30	at 3s. 6d.	5	5 0
			525	17 0
8186. <i>Slater's work. Pantiles.</i> — Stable	284	at 2s.	28	8 0
Cart-shed	284	at 2s.	28	8 0
Shelter-shed	570	at 2s.	57	0 0
Barn	426	at 2s.	42	12 0
			156	8 0
8187. <i>Estimate of the amount of the whole.</i> — Rubblework			350	0 0
Hewer's work			13	0 0
Roofing			525	17 0
Slater's work			156	8 0
Total.			1045	5 0

East Blanerne, Jan. 1833.

8188. — 2968. *Ditches and drains.* “The bank of earth with upright facing of turfs, with a bank behind.” This sort of ditch or fence, Mr. Gorrie observes, is only effective where the ditch lies between the bestial (cattle), and the faced dike (wall faced with stones), surrounding strips of plantations, orchards, or such enclosures as are not subjected to pasture. In such a case, this ditch, in waste lands, where the turf is well matted with the roots of grasses, and where the breadth occupied is not a considerable object, can be rendered a more effective fence than any other at so cheap a rate. Suppose the ditch to act in the capacity of an open drain, as well as a fence for sheep and cattle, it should be five feet wide at top, nine inches wide at bottom, and three feet deep. The turf should be cut in small squares of about nine inches, and about four inches thick, laid with the earth side uppermost, breaking joint every layer, and continued to the height of two feet nine inches, including the coping, with the

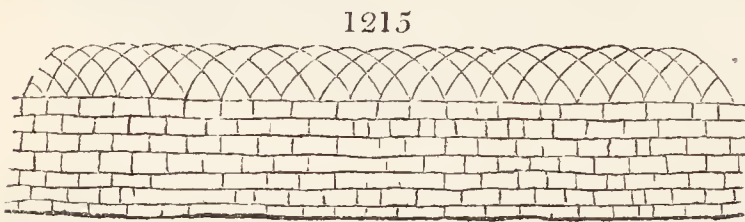
green side uppermost. The faced dike (*fig. 1214.*) will require to have nearly, but not altogether, the



1214

same inclination as the sides of the ditch, and the earth taken out of the bottom must be rammed in firmly at the back of the turf in course of the work: this form of fence prevents rubbing by cattle either with their sides or horns, a practice of which they are mischievously fond, when they can reach mud fences. If sheep are to be warded off, little or no scarsement (set back) should be made, as they would get up and walk the set back, though it might be only five or six inches in breadth, and from thence they would easily effect a passage over the faced dike: in this case, a single paling rail, about nine inches above the coping, will be necessary, to serve till a hedge of plants, suited to the soil and climate, has reached the height of two or three feet above the coping and become permanently effective. A

good and neat, as well as cheap, substitute for a rail, which requires sawing, posts, and nails, will be found where old larch plantations abound, and where branches about one inch and a quarter in diameter at the thick end, and six inches in length, can be got in sufficient quantities. These, having both ends sharpened, and stuck into the ground in the form of basketwork (*fig. 1215.*), will make a neat and effective fence. The larch branches so bent



1215

will last ten years, and will form an open wickerwork-like structure, which will serve as an efficient fence, impervious even to the attacks of black-faced sheep, the most troublesome dike-leapers of the breed. A fence of this nature surrounds a part of a small plantation at the west end of "Loudon's Howe" (in the parish of Kilspindie, Perth-

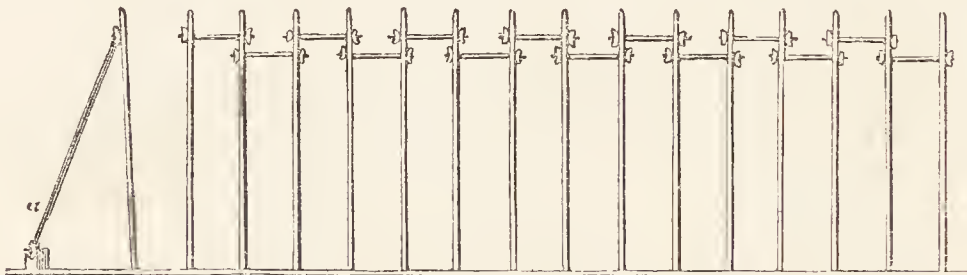
shire); so named to record the locality of some Scotch pine (*Pinus sylvestris*), seeds of which, furnished by Mr. Loudon from the forest of Hagenau, were sown in the spring of 1829, and, having been thinned out, are now in a prosperous state.

8189.—2991. *Cutting down old hedges.* In wastes, where ground is not of much value, and where it is not necessary to keep the ditch clean, a substantial hedge or live fence may be easily formed by cutting the plant halfway through, or rather more, near the root, and laying the shoots horizontally outward, at right angles with the line of fence. The side branches grow upward; and vigorous shoots spring from below the cut, forming in a short time a broad, dense, and impenetrable thicket. This practice is of advantage when hedges around plantations are necessary; and where, in the ordinary practice, they are liable to be overtopped, drawn up weak, and rendered inefficient. Some hedges have been treated in this manner by Mr. Beattie, an eminent horticulturist and forester, of extensive and successful practice, at Scone Palace, Perthshire.

8190.—3047. *Hurdle-making.* A detailed account of this operation, including descriptions of all the requisite tools, is given by Mr. Main in the *Quart. Jour. Agr.*, vol. iii. p. 647. to p. 653.

8191.—3039. *Fences composed of palings.* In the *Architectural Magazine* (vol. i. p. 79. and p. 235.) will be found two descriptions of wooden fences, which may be constructed without the use of nails, bolts, or iron, in any form. The details would occupy too much space to be introduced here; but the execution is simple enough; and the fences are suitable for countries where timber is more abundant than manufactured iron. *Fig. 1216.* is a description of fence recommended by Menteth. It consists of young

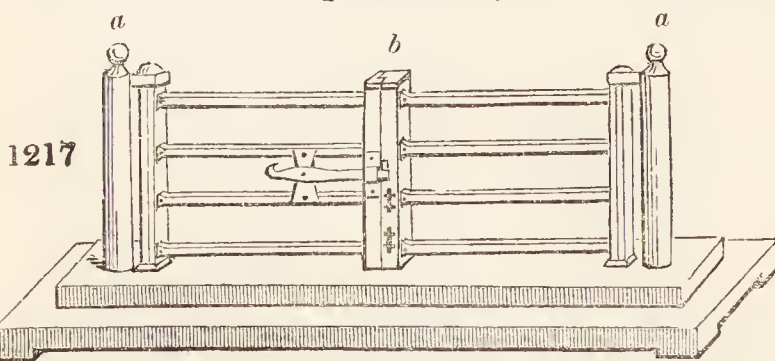
1216



larch poles, or rods, inserted in the ground at regular distances (according to the kind of animals to be excluded or separated), and joined together at top either by wires, short iron rods, or short slips of wood. At every twelve or fifteen feet, there may be a brace on one or both sides, or alternately, as shown at *a*.

8192.—3075. *Gates.* In the *Encyclopædia of Cottage, Farm, and Villa Architecture* will be found figured and described at length, some gates of a very superior description. That called Buchanan's Gate, which is formed entirely of iron, is remarkably strong and cheap; and Cottam's Gate is equally cheap, and nearly as strong. There are several gates for park entrances, with machinery attached for the gate-keeper to open them in the night-time without getting out of bed.

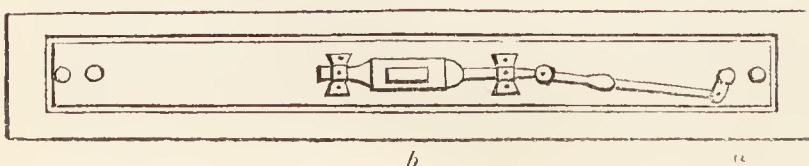
8193.—3088, *b* (3088, *a*, is a gate-stopper given in the first Supplement). *Russell's gate-stopper* is thus described in the *Highland Society's Transactions*, vol. xi. p. 236. *Fig. 1217.* is a view of two



1217

leaves of a gate fixed in the pivots *a a*. The centre, *b*, is formed of two uprights, checked into each other, and fixed together by a latch, and perpendicular bolt, which is drawn up by the hand. On the gate being opened, one of the uprights, *a*, having communication with a cast-iron box (*fig. 1218.*), gives motion to the connecting rod between *a* and *b*. When the leaves of the gate are opened, the connecting rod is shortened by means of the crank at *a*; and, when shutting, it is lengthened by pushing an inclined plane, or wedge, under the stopper, which is thus raised above the surface when the leaves are closed, and depressed when the leaves are opened. The iron box is intended to be sunk a few inches under ground, and covered with gravel. The posts and gate may be wholly of iron, or

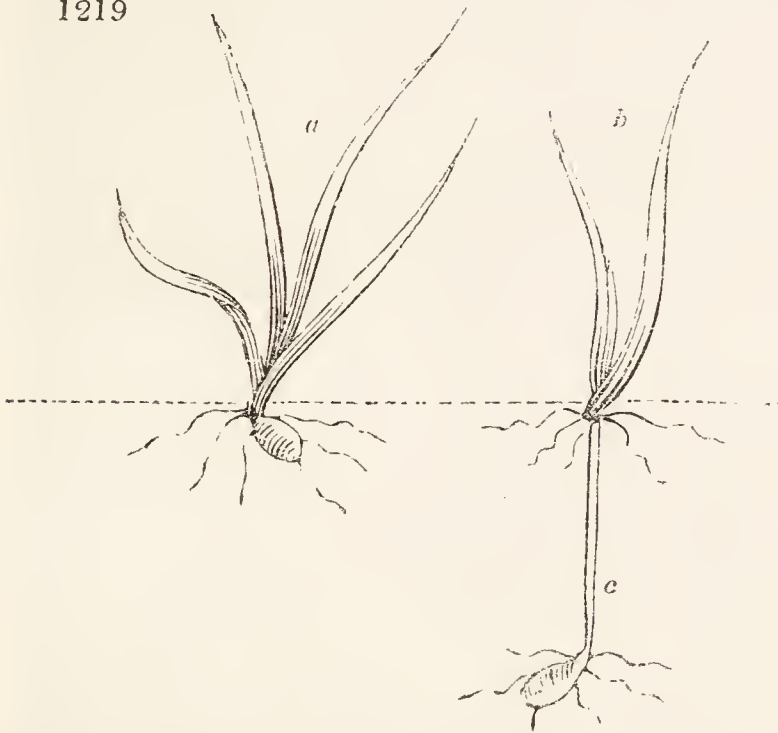
1218



of stone and wood. The advantage of this construction is, that the danger and annoyance resulting from a raised stopper in the middle of a pathway are obviated; for the moment the leaf of the gate is opened, the stopper begins to be lowered, and when the gate is wholly opened, it is level with the ground. (*Highland Soc. Trans.*, vol. xi. p. 236.)

8194. — 3148. *The due depth at which seeds should be deposited in the soil* is a very important subject, which has been discussed by Baron Voght, of Flotbeck, near Hamburg, in the *British Farmer's Magazine*, vol. iv.; and the following comment has been made on his paper by Mr. Main:—"If seeds be placed by accident or design at such a depth in the earth as to be out of the influence of the air, and though they may be surrounded by the requisite degrees of heat and moisture, they will nevertheless remain dormant. We have many instances of the truth of this in every-day practice, and of the imperishable properties of some kinds of seed when excluded from the influence of the air. If seeds are dropped on the bare surface of the ground, they will remain uninjured and unaltered so long as the air is perfectly dry; but in moist air germination commences, and the point of the root will quickly be protruded and find its way into the soil. This is the ordinary process of nature; but experience has taught us, that though nature distributes grain and other seeds generally on the surface of the spot where produced, yet there is a proper depth at which all seeds should be deposited, and which is specially suitable. This depth is obviously that which, while it yields the necessary degrees of heat, moisture, and darkness, is yet within the requisite influence of air. In the ordinary proceedings of farmers in the business of sowing, our implements, more than anything else, regulate the depth at which we lay in the seed. The drilling system is approved, not only from its equal distribution of the seed, but because by it seeds are also laid in at an equal depth; this last circumstance being regarded as one of the principal advantages of the machine. Now our author has endeavoured to show that seeds may be deposited too deep even by the drill; and in all cases when seed is sown before harrowing, much of it will be laid deeper than it should be. Of this there can be no doubt. Every one acquainted with sowing must allow that seed may be buried; and every body acquainted with the structure of culmiferous plants, and their manner of growth, must be convinced, by what the Baron has shown, that, if seeds are but just covered, so as to be sufficiently shaded from the sun's rays, it is enough. As proof of this, our author quotes several eminent authorities, who argue from the physical structure of the plants, as well as from the qualities contained in the seed, and which submit to the chemical action of the elements in the act of germination, that deep sowing is highly detrimental, and opposed to the provisions of nature. Explanatory of these assertions, the Baron has appended to his paper figures of five different kinds of corn in five different states of growth, caused by the different depths at which they had been deposited in the earth. Two of these are given in the annexed cut. (*fig. 1219.*)

1219



The dotted line is the surface of the ground: *a* represents a healthy plant of wheat from a seed laid in at the proper depth, viz. one inch beneath the surface; *b* shows the growth of a plant from a seed which has been laid in too deep. This last, it will be observed, vegetated, although two or three inches under the surface; threw out its seminal or first roots, and sent up its first shoot, bearing two leaves, into the air; but, as the first joint of the culm rises therewith, and remains near the surface, it also throws out roots, and entirely supersedes those that were first produced from the grain. Now, as this is only a provision of nature to accommodate herself to circumstances of accidental position, many cultivators have been of opinion that the placing of the seed at irregular depths makes but little or no difference to the ultimate strength of the plant, or to the crop. To this the Baron is decidedly averse, affirming that this unnecessary waste of vegetable power is both hurtful and unnatural. We think, and indeed we may venture to say we know, that he is right: for, without mentioning the needless waste of vigour, the young plant must be more liable to accidents

from the changes of the weather, slugs and insects, during the ascent of the first shoot, and before the principal roots are formed, than if it started from its natural position at once. To guard against over deep sowing, therefore, the Baron advises to sow nothing before harrowing; and, moreover, that great pains should be taken to pulverise the surface with fine harrows before the seed is sown, lest the corn should rise in rows, which, in broadcast husbandry, he condemns. Very different this from the custom of sowing wheat in this country, where the dexterity of the ploughman is often judged of by the regular exactness in which the ranks of corn appear on first coming up. This idea of the Baron's, though it be condemnatory of the drilling system (unless the machine be made to deliver very thinly), is, notwithstanding, very reasonable. The numbers of inferior ears, and the inequality of our samples of wheat, is mainly owing to the plants being too much crowded together in the dips between the furrows. Admitting that the principle of shallow sowing and equal distribution on a well-harrowed surface is in general right, still, as we have in this country very often a showery seedtime, it would be running a great risk on a clayey soil to harrow it down so finely as Baron Voght advises; and if a naturally loose and dry one, such an operation would probably bring up such a crop of weeds as would greatly injure, if not destroy, the crop. But on early-sowed fallows, all kinds of lent corns and small seeds, we think, from what we know of the nature of seeds generally, as well as from this writer's opinions, that the farmer cannot do wrong in following the Flotbeck manner of sowing broadcast." (*Brit. Farm. Mag.*, vol. iv. p. 290.) On the subject of this paragraph, and generally on all that respects the operations of agriculture considered scientifically, we would recommend to our young readers the careful study of the following cheap works: viz., *Mrs. Marcet's Conversations on Vegetable Physiology*; *Main's Illustrations of Vegetable Physiology*; *Lindley's Outlines of Horticulture*; and *Hayward's Inquiry into the Causes of the Fruitfulness and Barrenness of Plants and Trees*. The advantage which we propose to be attained by the study of such works, is the power of independent thinking, and of proceeding farther in scientific knowledge by observation and reflection. Many excellent practical agricultural works have a tendency altogether to preclude reflection, by describing and recommending only one practice, which has been found successful, without assigning any reasons why it has been so: instead of either assigning the reasons as the foundation for the practice; or giving different practices, and leaving the reasons to be discovered by the reader.

PART III.

AGRICULTURE AS PRACTISED IN BRITAIN.

8195. — 3385. The principal addition which we have made to this part of the work, is an abridgment of Sir Henry Parnell's *Treatise on Road-making*; which it was the more necessary to give, since, in the body of the work, the system of M'Adam may be considered as placed in a more prominent point of view than is warranted by its merits. There is also a valuable article on the frequent-drain system, and the plan and description of a machine for draining fen and other low lands by steam by Mr. Capper, Engineer, of Birmingham; and the engravings and description of a very complete apparatus for steaming food for cattle, by Mr. Mallet, of Dublin.

8196. — 3523. *Formation and management of roads.* The whole subject of road-making, road management, and road repairs, has lately been discussed by Sir Henry Parnell, in a *Treatise on Roads, wherein the Principles on which Roads should be made are explained and illustrated, &c.*, as practised by that distinguished engineer, the late Mr. Telford. In this *Treatise*, a number of received opinions which we had adopted are controverted, and we have therefore thought it advisable to give the essence of the work in a continued series of paragraphs.

8197. *In the introduction*, the author, after setting forth the advantages of good roads, describing the roads of the Romans, and noticing the present state of roads in the principal countries of Europe, speaks of those of England. Little attention was paid to English roads previously to 1629, when a proclamation was issued for preserving roads by limiting the weights to be drawn over them. The first turnpike road was established by law in 1653, through Hertfordshire, Cambridgeshire, and Huntingdonshire. Nothing, however, of importance was done to raise the character of English highways, till after the peace of 1748. In Arthur Young's *Six Months' Tour*, published in 1770, a frightful picture is given of the roads in Lancashire and Cheshire, and travellers are cautioned to avoid them "as they would the devil, for a thousand to one they break their necks or their limbs, by overthrows or breakings down." The ruts on these roads are described as in some places four feet deep, filled with floating mud, with here and there a loose stone, which serves no other purpose than that of jolting a carriage in a most intolerable manner. Between 1760 and 1764, 452 turnpike acts were passed; and in twenty-four years, from 1785 to 1809, upwards of 1000 have been passed, and nearly 20,000 miles of road formed, or improved. But, notwithstanding this progress, the operations have been directed with such negligence or ignorance, "that at this moment there is not a road in England, except those recently made by some eminent civil engineers, which is not extremely defective in the most essential qualities of a perfect road." (p. 26.) The crookedness and steepness of almost every great road, is owing to its being made on the lines of the footpaths of the aboriginal inhabitants, which afterwards became the horse tracks; and, finally, as society advanced, the only legal line left for carriages. This state of things is not only dangerous, but "disgraceful to the national character." (p. 26.)

8198. *The true principles of road-making* have not yet been followed in this country. "The breadth of a road is seldom defined to a regular number of feet by straight and regular boundaries, such as fences, footpaths, mounds of earth, or side channels. The transverse section of the surface, when measured, is rarely to be found of a regular convexity. The surface of all the roads, until within a few years, was everywhere cut into deep ruts, and even now, since more attention has been paid to road works, though the surface is smoother, the bed of materials which forms it is universally so thin, that it is weak, and consequently exceedingly imperfect. Drainage is neglected; high hedges and trees are allowed to intercept the action of the sun and wind in drying the roads; and many roads, by constantly carrying off the mud from them for a number of years, have been sunk below the level of the adjoining fields, so that they are always wet and damp, and extremely expensive to keep in order, owing to the rapid decay of the materials which are laid upon them." (p. 27.)

8199. *Road-makers in England* have hitherto been wholly ignorant of the scientific principles on which the making of good roads depends. Even government is ignorant on the subject, as appears evident from recommending the M'Adam system as the perfection of road-making. Notwithstanding the extent to which science is displayed in our canals, docks, bridges, and other public works, it was not till 1830 that land proprietors began to understand the value of good roads, and to be aware, that large funds, considerable science, and constant attention, are necessary to bring them into, and keep them in, a perfect state. (p. 29.)

8200. *In Scotland and Ireland*, however, a better system has been followed for some time. In 1790, Lord Daer introduced the practice of laying out roads with a spirit level, and having no greater inclination than one in forty, even in the most hilly country; and this practice has been generally followed. In Ireland, the system of statute labour was abolished in 1763, and, the business of making roads being committed to the grand juries, improvements soon became so general, that Arthur Young, about 1777, found everywhere better roads than in England. The British legislature made a great effort for improving the roads of the Highlands of Scotland in 1803; and 875 miles and 1117 bridges, were constructed under the direction of Mr. Telford.

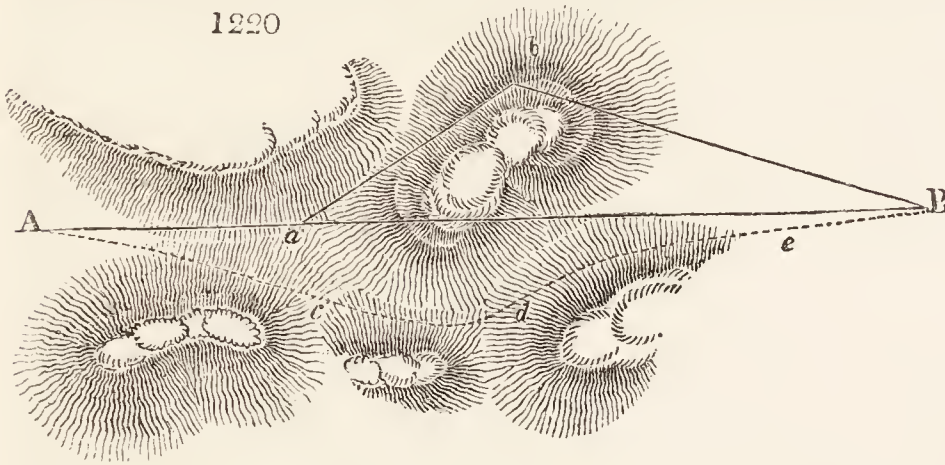
8201. *In England, a great advance in road-making was made, in 1815*, by the employment of Mr. Telford, by parliament, to improve the Holyhead road, which is now "acknowledged, by all persons competent to form a correct judgment on works of this kind, to be a model of the most perfect road-making that has ever been attempted in any country." (p. 35.) The following passage at once points out the use of the treatise, and the grounds on which the practice recommended are founded.

8202. *The obvious utility of a work on road-making*, "explaining the principles on which this business should be carried on, and containing an illustration of those principles by a reference to the plans, specifications, and contracts which have been made use of in constructing this extent of new road, through a country presenting every kind of difficulty, has suggested the present publication. The object of it is to point out, in a clear and concise manner, the best method of tracing out and constructing roads, under every variety of circumstances; and it is confidently expected, that the course which has been pursued of proceeding on experience by referring to the identical plans, specifications, and contracts by which so great an extent of perfect road has been successfully made, will be found to have attained this object."

8203. *Rules for tracing the line of a new road.* Surveys and levels should previously be made, and plans, and vertical sections, transverse and longitudinal, should be laid down on paper. The scale for the plan should be sixty-six yards to an inch, and for the sections, thirty feet to an inch. The depth of rivers to be passed, and the height of their highest floods; the depth of bogs or morasses; the natural drainage;

situation of gravel-pits or quarries, should all be marked on the plan. As a general rule, a straight, level, and cheaply executed line is the best; subject, however, to modifications arising from the comparative cost of annual repairs, and present and future traffic, &c. When a deviation is made from a straight line, proceed in a direct line from a new point, and if another interruption occurs, again change the direction, always keeping in view the imaginary straight line between the extreme points of the road, so as to deviate from it no more than is absolutely necessary. "Thus, for instance, if it be decided to have no greater rate of inclination than one in thirty-five, on a new line of road, from A to B in *fig. 1220.*, and the surveyor, when he arrives at the point *a*, finds a greater inclination than this, he must incline from the direct line to *b*. Having then gained the summit of the hill, he does not endeavour to get back into the original straight line A B, but pursues the direct line *b B*, unless he is again obliged, from a similar cause, to deviate from it. This part of the survey being accomplished, it will then become necessary to examine the practicability of making a direct line of road, between A and *b*, instead

1220



of going to the point *a*. When hills are high and numerous, it sometimes appears, from a perambulation and inspection of the country, to be advisable to leave the straight line altogether from the beginning, in order to cross the ridges, at lower levels, by a circuitous course, in the way represented by the dotted lines *A c d e B*, in the above figure."

8204. *The saving of perpendicular height to be passed over by a road* has not received that attention from engineers which it deserves. When the inclination of a hill is not greater than one in thirty-five, it may be driven down with perfect safety at the rate of twelve miles an hour; but if the road is so steep as not to admit of going faster than six miles an hour, there is a loss of half a mile in distance for every half mile down the hill; besides rendering necessary the use of the drag, which is at all times more or less dangerous. "An inclination of one in thirty-five is found by experience to be just such an inclination as admits of horses being driven in a stage coach with perfect safety, when descending in as fast a trot as they can go." (p. 45) "A perfectly flat road is to be avoided, if it is not to be raised by embanking, at least three or four feet above the general level of the land on each side of it, so as to expose the surface of it fully to the sun and wind; for if there is not a longitudinal inclination of at least 1 in 100 on a road, water will not run off." (p. 47.) The great fault of all roads in hilly countries is their constant ascent and descent before they gain the highest point of the country they have to traverse; by which the number of feet ascended is increased to an extent far greater than would have been the case, if each height when once gained were not lost again by the succeeding descent. Thus a horse must ascend upwards of 1300 feet between London and Barnet, though the latter is only 500 feet higher than the former, while a horse going from Barnet to London must ascend nearly 800 feet, instead of descending 500 feet. (p. 48.) In carrying a road across a deep valley, the descent and ascent, and the quantity of material wanted, will be diminished by inclining the line upwards, where the bottom of the valley rises, rather than downwards where it falls. Where valleys are narrow and steep, the road may be more economically carried across on viaducts; some of the finest of which in Britain have been erected by Mr. Telford, at Mousewater, Birkwood Burn, the Menai Straits, &c. Hills may sometimes be passed through by means of a tunnel instead of deep cutting.

8205. *Rivers have been allowed to direct the line of a road too readily*, from timidity about incurring the expense of bridges, &c.; but if even a quarter of a mile of road be saved, by expending several thousand pounds on a bridge and its embankments, the saving to the country in annual repairs and horse labour will soon pay off the original cost.

8206. *Bogs and marshes* being elastic, the foundation of an intended road over them requires to be drained and loaded with earth to destroy the elasticity of the subsoil; which, by destroying the momentum of a carriage passing over it, greatly increases its draught.

8207. *A proper exposure to the sun and winds* is of great importance to a road. The north side of a valley running east and west, ought always, if possible, to be preferred, and trees, high walls, and every thing on the south margin of a road, which obstructs the united action of the sun and wind, removed. Damp roads, of whatever material they may be composed, wear away rapidly under the weight and pressure of heavy carriages. Open roads afford free respiration to horses, in consequence of which they can perform much more work; a fact which those farmers are well aware of, that have confined horse-tracks for their threshing mills. The expediency of causing a road to deviate from its straightest direction, in order to pass through a town, must depend on the principal object of the road. In general, little attention should be paid to the opposition of inhabitants of towns to new roads, and still less to the proprietors of parks and gardens.

8208. *Principles of road-making.* A beaten track of knowledge is but a bad guide, when, amongst several ways, the best is to be preferred. The most important, and the most obviously correct principle of road-making is, that it should be of such a degree of substance as to bear the weight and number of the carriages that are to pass over it. This principle is almost universally violated, and the crust of roads will be found generally not to exceed more than three or four inches, instead of a coating of six inches, of the hardest kind of stone, broken into small pieces, and laid on a regular foundation of rough pavement. The external forces which counteract the momentum of carriages passing over roads are collision, friction, gravity, and air.

8209. *Collision* is produced by protuberances, and friction by a soft or elastic surface. Smoothness and hardness, therefore, are the chief qualities of a perfect road. That a road may be hard, it is not sufficient to lay upon a prepared bed of earth merely a coating of broken stones, for the carriages passing over them will force those next the earth into it; even if a coating of from sixteen to twenty inches were laid on. Mr. Telford's plan, of making a regular bottoming of rough, close-set pavement, and covering it with six inches of broken stones, secures the greatest degree of hardness that can be given to a road. "By laying the stones in making the bottoming with their broadest face downwards, and filling up the interstices closely with stone chips well driven in, the earthy bed of the road cannot be pressed up so as to be mixed with the coating of broken stones. This coating, therefore, when consolidated, will form a solid uniform mass of stone, and be infinitely harder than one of broken stones when mixed with the earth of the substratum of the road. It is by proceeding in the way here recommended that the friction of wheels on a road will be reduced as much as possible."

8210. *Friction.* "Experiments have proved that, on a well-made pavement, the power required to draw a waggon is 33 pounds; on a road made with six inches of broken stone of great hardness, laid on a foundation of large stones, set in the form of a pavement, the power required is 46 pounds;

on a road made with a thick coating of broken stone, laid on earth, the power required is 65 pounds; and on a road made with a thick coating of gravel, laid on earth, the power required is 147 pounds." These experiments, it is shown, correspond with results deduced from the laws of science, and are in direct opposition to the doctrines laid down by Mr. M'Adam, viz.: "That a foundation or bottoming of large stones is unnecessary and injurious on any kind of subsoil. That the maximum strength or depth of metal requisite for any road, is only ten inches. That the duration only, and not the condition of a road, depends upon the quality and nature of the material used. That freestone will make as good a road as any other kind of stone. That it is no matter whether the substratum be soft or hard."

8211. *As gravity* acts in a direction perpendicular to the plane of the horizon, it neither accelerates nor retards the motion of a body moving on a road which is perfectly horizontal. When, however, a road is not horizontal, the action of gravity becomes a positive impediment.

8212. *The resistance of air* to a body moving along a road is variable, and has no relation to the state of the road. Wind travelling at the rate of fifteen miles an hour has a force of one pound per square foot; at twenty-five miles an hour, or a very brisk gale, three pounds; at thirty-five miles per hour, or a high wind six pounds; at fifty miles an hour, or a storm, twelve pounds. A very little reflection will show, that the resistance offered by wind to any body moving against it will be as the motion of that body, and that driving stage-coaches at a rapid rate against high winds is attended with a ruinous waste of horse labour.

8213. *Forming a road.* The great art, in carrying a road over a high elevation, is to lay it out so as to prevent it having any fall from the point of departure to the highest point. This can only be done by lowering heights and raising hollows, and the engineer will show his skill in effecting this by the least quantity of cutting and embanking. In cutting through hills, the slopes of the banks should in general not be less than two feet horizontal to one foot perpendicular; but on the south side of a road which runs east and west, the inclination may be three to one, in order to secure the action of the sun and wind from the road. No person should be intrusted to form high embankments who has not had considerable experience as a canal or road maker; "for, if the base of an embankment be not formed at first to its full breadth, and if the earth be not laid on in regular layers or courses of not exceeding four feet in thickness, it is almost certain to slip. In forming high embankments, the earth should be laid on in concave courses; for, when laid on convexly, the courses are for ever slipping." (p. 83.) "In forming embankments along the sides of hills, or what is called side forming, the rule that should be followed is that the slope to be covered should be cut into level slips to receive the earth, otherwise it will be very liable to slip down the hill: in such cases, the earth should be well compressed, and great care should be taken to interrupt all the land springs about it by proper drainage. For this purpose, a drain should be cut on the upper side of the road, and open drains should be made on the side of the hill above the road, to catch the surface water of the hill." Rocks of different kinds, and chalk, will stand at a steeper slope than common soils; chalk or chalk marl will stand at one to one; hard sandstone at a quarter to one, or nearly perpendicular; while plastic clay requires a slope of three to one.

8214. *Drainage.* On flat and wet surfaces, there should be a drain at each side of the road, at least three feet deep below the substratum of the latter. Where main drains cannot be formed, as on the side of a hill, near houses, &c., then covered drains, substantially built of stone or brick, must be resorted to. If springs rise in the centre of the road, drains must be made to them so as completely to dry the bed of the road. In cuttings, that is, where a road is cut through or along the side of a hill, it becomes necessary, in almost every case, except that of solid rock or gravel, "to make drains of small dimensions from the centre of the road to the side drains. These drains should form an angle in the centre of the road, in the shape of a V, technically called mitre drains: the angle or splay of these drains should depend upon the inclination of the road; it should not make the inclination of the drains exceed an inch in 100; for if it be greater, the run of the water will undermine the sides, and injure them. These mitre drains should be 9 in. wide at bottom, 12 in. wide at top, and 10 in. deep. These drains should be placed at about sixty yards from each other, or about thirty in the mile; but if the soil be wet, this number should be considerably increased. They are to be filled with rubblestone, or cleansed gravel. If gravel is used, a draining tile should be laid along the bottom before the gravel is put in. The upper part of these mitre drains should communicate with the road materials, so as to draw the water from them. According to the inclination of a road, and the form and wetness of the country through which it passes, cross drains of good masonry should be built under the road, having their extremities carried under the road fences. One of these drains should be made wherever the water would lie on one side of the road, and can only be got rid of by carrying it to the other side. When the road passes along the slope of a hill or mountain, a great number of these drains are necessary to carry off the water that collects in the channel of the road on the side next the high ground. They should be placed at from 50 to 100 yards' distance from each other, according to the declivity of the hill; so that the side channels may not be cut by carrying water too far. In these situations inlets should be built of masonry, to carry the water from the side channel of the road into the cross drains." After every precaution in respect to draining has been taken, injury from water should be farther secured by convexity of surface, and by side channels. "These side channels will be formed by the angle where the slope of the side parts of the surface of the road abuts against the edge of the footpath, or other defining bounds of the roadway. They will be capable of carrying off a great quantity of water, without being made into the form of a square-sided drain." The reduced particles of the materials of a road, when wet, assist the wheels in rapidly grinding down the surface, in the same manner as a lapidary cuts his jewels with the powder of the same kind of stone mixed with water.

8215. *Different kinds of roads, and modes of constructing them.* — *Railways* of wood were first introduced about 1602, and cast iron seems to have been first employed in them in 1667. A railway with a declivity of 1 in 96, or 55 feet in a mile, will admit of one horse drawing from 12 to 15 tons down the declivity, and 4 tons up it. On a level railway, a horse can draw 12 tons. In some situations, where all the traffic is one way, the loaded carriages descend by their own gravity, and pull up the empty ones. In others, the loaded waggons drag with them another wagon or truck, containing the horses which are to pull up the empty waggons. This is the case on the Darlington railway, where the rest which the horses receive while riding from one point to another, is found to renew their vigour. (p. 105.) "The expense of constructing railways depends upon the nature of the ground they are made over, and the purpose for which they are intended. In many situations, where the trade is altogether a descending one, and water scarce, they are preferable to canals, and may be constructed cheaper; but for general traffic, over a wide extent of country, they do not afford as cheap a means of conveyance as canals. The expense of carrying goods by locomotive engines on railways much exceeds that on canals, or on railways with horses."

8216. *The plan of constructing a railway* "should be arranged so as to be adapted to the purposes for which it is intended. If for local or private purposes, the same expense is not necessary as when the railway is for general and public traffic. In the former case, the rails should not be so heavy, so strong, or so expensive, as when employed for the latter, and the blocks may be of much less weight, and the fastenings less perfect. To form a perfect railway for general traffic, on which locomotive engines are to be employed, the surface of the ground over which it is to be made should be reduced, by cutting, filling, or tunnelling, to rates of inclination not exceeding 1 in 300. The rails should be of wrought iron, of not less than fifty pounds to the yard and they should be laid on blocks of hard solid stone, each of not less than five cubic feet. These blocks should be set on a firm, solid foundation of hard broken stones, at least two feet thick, technically called ballasting. The space between the blocks should be filled up with rubble stones, and the whole should be covered with gravel up to the level of the bottom of the rails

What has been said relating to the draining of a turnpike road, should be strictly attended to in constructing railways. Railroads on which locomotive engines are employed should not be carried across a turnpike road on the same level with the road, but by tunnels or viaducts. When horses are employed, it is not so objectionable to cross roads on the same level; it should, however, if possible, be avoided: when it is impossible, great care should be taken to keep the top of the rails on a level with the surface of the road, or rather below it, and the space between the rails should be kept always filled to the same level. Notwithstanding it seems to be universally believed that the practicability of making use of locomotive engines on railroads has been established by what has taken place on the Manchester and Liverpool railway, there are many competent judges who are of opinion that it would not have succeeded had it not been for the peculiar circumstance of its forming a direct communication between two such very populous, opulent, and enterprising trading towns as Manchester and Liverpool." (p. 116.)

8217. *Paved roads*, where there is much traffic, will be found better for conveying goods than turnpike roads, constructed as they usually are. "On a smooth, well-made pavement, quite horizontal, it appears, from the experiments made with Mr. Macneill's machine, that the resistance to draught is not more than the hundredth part of the weight of the carriage and its load, when the carriage is properly constructed, and mounted on straight and cylindrical axles. According to this, a horse of great power would be able to draw on such a road, if horizontal, $6\frac{3}{4}$ tons; and if with no greater inclination than 1 in 50, $2\frac{1}{4}$ tons. A common opinion prevails, that because paved streets have almost everywhere been suffered to be rough and imperfect, all pavements must necessarily be rough and bad; but a slight degree of consideration will show that this opinion is without foundation, and that, in point of fact, the cause of rough and bad pavements is bad management, arising from the ignorance of those employed to make them, or the want of sufficient funds for executing good work." (p. 120.)

8218. "*The first object to be secured is a good foundation.* For this purpose, a bed should be formed with a convexity of two inches to ten feet, so as to admit of twelve inches of broken stones being laid upon it. These should be put on in layers of four inches at a time. After the first layer is put on, the street should be kept open for carriages to pass over it. When this first layer has become firm and consolidated, then another layer of four inches should be put on, and worked in as before, care being taken to rake the ruts and tracks of the wheels of carriages, so that the surface may become smooth and consolidated. The same process should be repeated with the third layer of stones, by which means a solid and firm foundation will be established, of twelve inches in thickness, for the dressed paving-stones to lie upon. The next thing to be attended to, is to provide proper paving-stones. These should be cut into a rectangular shape, and of the hardest quality that can be procured; granite is the best, but whinstones, some descriptions of limestone and freestone, will answer the purpose." (p. 133.)

8219. *With regard to the size of the stones*, that should be regulated by the intercourse. The streets should be divided into three classes, according as the thoroughfare is greater or less. For streets of the first class, or greatest thoroughfare, the stones should be ten inches in depth, from ten to fifteen inches in length, and from six to eight inches in breadth on the face. For streets of the second class, the stones should be eight inches in depth, from eight to twelve inches in length, and from five to seven inches in breadth on the face. For streets of the third class, the stones should be six inches in depth, from six to ten inches in length, and from four to six inches in breadth on the face.

8220. *After having prepared a proper bottoming*, the greatest care must then be bestowed in setting the stones. Fine gravel must be provided, cleansed from all earth, to form a bed over the bottoming of two inches thick, for the stones to be set in. Strong mortar must also be provided; and, besides the common tools, each pavior should have a wooden maul, the head of which should be made of beech or elm, and should weigh about fourteen pounds. The stones should be selected so that they may be laid in even courses, and so as to match, as nearly as possible, in each course, with regard to breadth and depth.

8221. *In paving*, the pavior should first set a stone on the gravel bed, by striking it strongly downwards with the maul, and then on its sides. Then he should lift it out of its berth, and put mortar on the sides of the two adjoining stones; after which he should again place the stone in its berth, and strike it as hard as he can, downwards and sidewise, with the maul, till it is fastened in the position in which it is to remain. Each stone should be set in this manner; and, when the pavement is finished, it will be so firm as not to require ramming.

8222. *The crossings for foot passengers* should be raised above the level of the pavement, by giving a moderate convexity to the bottoming. They should be made with stones of the size for streets of the first class, more accurately dressed.

8223. *The pavement should be formed with a regular, but very moderate, convex surface*, by giving the bed for it the convexity already mentioned. There should be no gutter or other channel but that which will be formed by the angle made by the surface of the pavement abutting on the kerbstone. The kerbstone of the pavement should be made of long blocks of stone, of a quality sufficiently hard to resist the shocks of wheels striking it. These blocks should be bedded in gravel, and joined with cement: they should be sunk four inches at least into the ground, and be six inches above the pavement.

8224. "*The foot pavements* should be made of well-dressed flags; each flag to have its sides rectangular, and to be set in mortar, with a very close joint, upon a strong gravel bed, of six inches in depth. The flagstones should be at least two inches and a half thick; the surface of the foot pavement should have a declivity at the rate of one inch in ten feet, towards the street."

8225. *The paving and repairing of paved streets* should be done by the superficial yard, and by contract; the specifications ought to be drawn up with the greatest care, and accompanied by all necessary plans and sections. Repairs require to be made the moment they are discovered to be necessary. As soon as a single stone gets out of its proper bearing, it should be taken up, and relaid with new bottoming; and a complete bottoming should always be laid down over pipes when the pavement is broken up in order to get at them. The paving-stones should be laid on loose at first, and left till the bottoming is consolidated, and then they should be taken up and carefully set in mortar.

8226. *Paved streets have been objected to*, on account of the noise made by carriages passing over them. The noise chiefly arises from the boxes of the wheels striking the arms of the axle-trees; and, therefore, when a paved street is exceedingly rough, the strokes of the axles are frequent and violent. But when a paved street is properly made, the surface of it will be comparatively smooth, and then both the number and force of the strokes of the axles on the boxes will be greatly reduced, and consequently the noise made by carriages. When a carriage passes from a rough to a well-made pavement, the difference of sound is immediately perceivable. It is supposed by some persons, that, if the streets were paved in the way proposed, their surface would be too smooth for horses to go safely over them; but this supposition is not well founded, except when that kind of stone is used which becomes polished by wear. Scotch granite and some other kinds of stone do not become polished, and, therefore, pavements made with them will never have so smooth a surface as to be unfit for horses. A horse properly shod will seldom slip on a pavement, or fall, unless when thrown down by being turned too short, or other careless management. The enormous expense which has been incurred by adopting the plan of broken-stone streets in London, in place of pavements, is fully established by the returns which were presented to the House of Commons in the year 1827. By this return it appears that the first cost of converting 1 mile 250 yards from a pavement into broken-stone road was 12,842*l.*; and that the annual expense of maintaining this 1 mile 250 yards has been 4003*l.*, being at the rate of 1*s.* 9*d.* per superficial square yard.

8227. *Roads partly paved, and partly made with broken stones.* "Whenever the traffic of a road is so great as to wear down three inches of hard broken stones in a year, the middle part of it should be paved. At this rate of wear half a cubic yard of materials will be requisite for every lineal yard of eighteen feet of the breadth of the road. This will make the expense of new stones alone, for a road thirty-six feet

wide, per mile, per annum (supposing the cubic yard of broken stones to cost 12s.), amount to 1056l. If the middle twenty feet of the broken-stone streets in London, where the traffic is very great, were paved, a great expense would be saved; at the same time that the convenience of broken-stone roadways would not be taken away." (p. 146.)

8228. *"A road with a foundation of pavement, and a surface of broken stones.* The following specification of the manner of constructing a road of this kind, of thirty feet in width, is taken from a contract for making a part of the Holyhead road. Upon the level bed prepared for the road materials, a bottom course or layer of stones is to be set by hand in form of a close firm pavement. The stones set in the middle of the road are to be seven inches in depth; at nine feet from the centre, five inches; at twelve from the centre, four inches; and at fifteen feet, three inches. They are to be set on their broadest edges lengthwise across the road, and the breadth of the upper edge is not to exceed four inches in any case. All the irregularities of the upper part of the said pavement are to be broken off by the hammer, and all the interstices to be filled with stone chips firmly wedged or packed by hand with a light hammer; so that, when the whole pavement is finished, there shall be a convexity of four inches in the breadth of fifteen feet from the centre. The middle eighteen feet of pavement is to be coated with hard stones to the depth of six inches; four of these six inches to be first put on, and worked in by carriages and horses, care being taken to rake in the ruts until the surface becomes firm and consolidated; after which the remaining two inches are to be put on. The whole of this stone is to be broken into pieces as nearly cubical as possible, so that the largest piece, in its longest dimensions, may pass through a ring of two inches and a half inside-diameter. The paved spaces on each side of the eighteen middle feet are to be coated with broken stones, or well-cleansed strong gravel, up to the footpath or other boundary of the road, so as to make the whole convexity of the road six inches, from the centre to the sides of it; and the whole of the materials are to be covered with a binding of an inch and a half in depth of good gravel, free from clay or earth." (p. 150.)

8229. *The work of setting the paving-stones* must be executed with the greatest care, and strictly according to the foregoing directions, or otherwise the stones will become loose, and in time may work up to the surface of the road: when the work is properly executed, no stone can move. If the work be executed by contract, the inspector should see all the operations as they are going on; he should walk over the pavement when it is completed, and try whether the stones be firmly fixed; and he should not allow any broken stones to be laid on over the pavement till it has undergone an examination of this kind.

8230. *In breaking stones*, the workmen would be required to break them as nearly cubical as possible: when this rule is not attended to, a great quantity of materials is wasted by first splitting the stones into thin slices, and then breaking them into pieces that are too small and too thin. If the stones or top metal are not broken very small, the proper degree of smoothness of surface will not be obtained. When stones are very hard, they never make a very smooth surface; limestone will make a much smoother surface than whinstone and other harder stones, but they should not for this reason be preferred to harder stones; for these will wear longest, carriages will run lighter over them, and the expense for scraping and repairing will be less. All the soft kinds of stones make heavy roads in wet weather; and in dry weather there will be more friction upon roads made with them, because there will be more dust on their surface.

8231. *With respect to the convexity of a road*, it should be so arranged that it should be slight in the middle. In giving a convexity of six inches to a road of thirty feet in breadth, the convexity at four feet from the centre should be half an inch; at nine feet, two inches; and at fifteen feet, six inches. This will give the form of a flat ellipsis.

8232. *The binding*, which in the foregoing specification is required to be laid on a new-made road, is by no means of use to the road, but, on the contrary, injurious to it. It is, however, unavoidable, when a long piece of new road is to be opened; for, without it, the wheels, by sinking into the new materials, would make the draught of the carriages much too heavy for the horses. This binding, by sinking between the stones, diminishes the absolute solidity of the surface of the road, lets in water and frost, and contributes to prevent the complete consolidation of the mass of broken stones. In a district of country where any sort of coarse stone can be got for making a pavement, it will be cheaper to make a road with a pavement and six inches of broken stones, than with ten inches of broken stones without a pavement.

8233. *Roads made with foundations of rubblestones, and a surface of broken stones*, will answer for cross roads and others, that do not communicate between large towns, collieries, or quarries. The rubble-stones should be reduced so as none of them exceed four pounds in weight; they should be laid in a regular bed, seven inches deep in the middle of the road, and four inches at the sides, and a coating of small broken stones, not exceeding an inch in diameter, should then be laid over them.

8234. *A road made wholly of broken stone*, of twelve inches in thickness in the middle, and six inches at the sides, may be found suitable for light carriages and little traffic. The stone should be laid on in layers, allowing each layer to be worked in and consolidated, before a fresh one be laid on. "This plan of road-making, however, having of late been recommended, as greatly superior to all other plans, by persons who profess to be experienced and scientific road-makers, a number of turnpike trustees have adopted it; but experience has fully established its unfitness for roads of great traffic, in comparison with roads made with a proper foundation. In point of fact, there is nothing new in this plan; for all the roads of the kingdom have been made in this way, and the universal defect of them, namely, their weakness, is the result. A road made on this plan will require, for two or three years after it is said to be finished, the expending of large sums in new materials, to bring it into anything like even an imperfectly consolidated state; and, after all that can be done, such a road will always run heavy, and break up after severe frosts; for as the natural soil on which such a road is laid is always more or less damp and wet, it will necessarily keep the body of materials, of which the road is made, damp and wet; in consequence of which, the surface of the road will wear down quickly. Hard frosts will penetrate through the materials into the under-soil; and, when the thaws take place, will break up the whole surface. It is in this way that the ruinous state of most roads, after severe frosts, is to be accounted for."

8235. *Roads made with gravel*. The bed being prepared, a coating should be laid on four inches thick and carriages allowed to pass over the road, the ruts being filled in as soon as they appear. When the first coat has become firm, a second coat once screned, that is, freed from the larger stones and the smaller gravel, should be laid on three inches thick, and treated as before. A third coat of well-riddled gravel should afterwards be put on, taking care to break all pebbles exceeding an inch and a half in diameter; and this process of putting on layer after layer, allowing a considerable interval between, should be continued till there is a body of gravel on the road sixteen inches thick, declining convexly towards the sides, where the thickness may be ten inches. The strongest and best part of the gravel should, of course, be put in the middle part of the road. A road made with gravel in the way here recommended will be much stronger than gravel roads usually are; but it will be much inferior to one made with stone materials. The roundness of the gravel stones prevents them from becoming consolidated by pressure, so as to form a perfectly hard road surface; and when the gravel consists of limestone, flint, freestone, sandstone, or other kinds of weak stone, it is so rapidly pulverised that the friction produced by wheels passing over it adds greatly to the labour of horses."

8236. *Fences*. Walls are preferred to hedges, because they require less room; and at once give a neat and finished appearance to a road. Hedges are to be planted on banks, and the ditch is always to be on the field side of the bank. All road-fences should be kept as low as possible, in order that they may not intercept the sun and wind. Hedges should be trimmed every year, in August and September, applying a line and templet (mould) to insure regularity.

8237. *Road masonry.*— *Bridges* ought to be placed in a direct line with the road which is to pass over them, and, if possible, at right angles to a straight reach of the river or stream. The width of bridges on turnpike roads near large towns should not be less than forty feet, and on other roads thirty-six, thirty, twenty-four, or twenty feet. The inclination of the sides of bridges should never exceed one in thirty. The waterway of the bridge should be ample, so as to allow the highest floods to pass away freely.

8238. *Retaining walls*, or those which are built on the hill side of a road in a rugged and precipitous country, require to have a secure foundation, and to be carried up with a curved batter (slope) on the face or side next the road, at the rate of one inch and a half of curve for every foot in height.

8239. *Breast walls*, or those which support a road on its lower side, should be built in the same manner as retaining walls; and, like them, they should increase in thickness downwards, at the rate of two inches and a half for every foot in depth, by a regular slope on the outside.

8240. *Fence-walls* may be built without mortar if the stones are flat-bedded.

8241. *Cross drains* should be built of good masonry, eighteen inches in the clear.

8242. *Inlets* or openings for the water from the side-channels of a road should be in stone masonry, ten inches by sixteen inches, covered with sound flagstones, the top of which would be at least six inches

above the level of the channel, as in *fig. 1221.*, in which *a* is the flagstone, *b* the opening for the water, *c* the channel of the road, *d* the cross drain, and *e* the surface of the footpath. Inlets may likewise be made along the channels, and should be covered with iron gratings.

8243. *Outlets* may be built of brick or stone, about a foot square, for the purpose of carrying the water from the channels under

the footpath or fence into the outside drains, or to the cross drains, as the case may be.

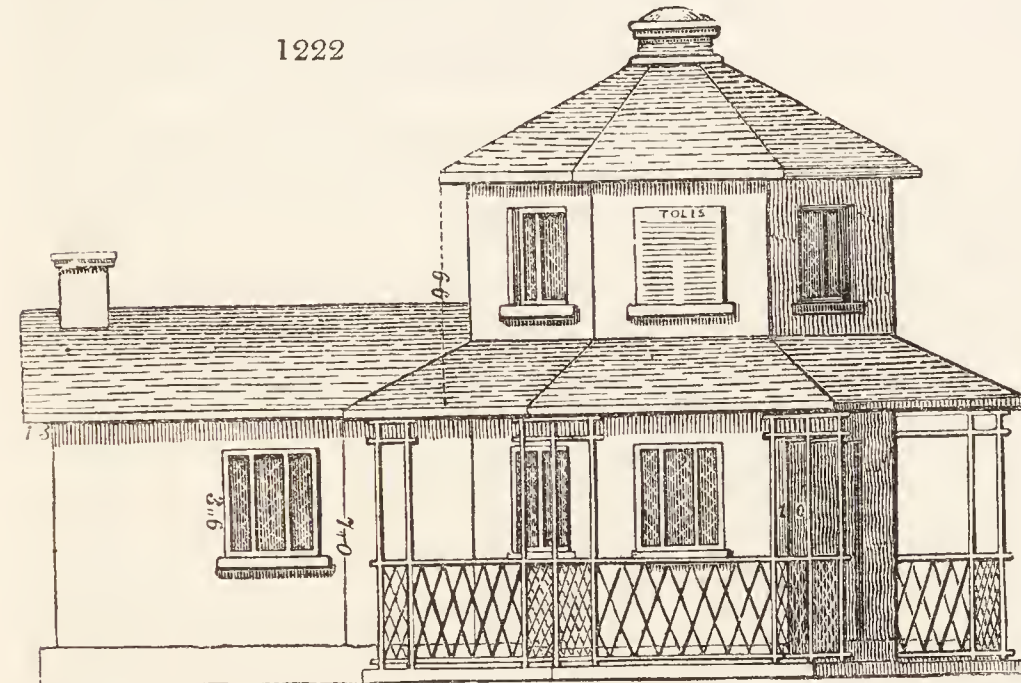
8244. *Depôts* are made along roads for holding materials for repairs; they are rectangular recesses, with back and side walls, the former twelve, and the latter each two yards and a half in length. This space will hold twenty-five cubic yards of materials; and four depôts on a mile, at 428 yards apart, will contain 100 cubic yards. Depôts should never be farther apart than a quarter of a mile, so as to admit of the materials being moved from them in barrows.

8245. *Toll-houses* are recommended to be built in a strong substantial manner, and to be made suitable

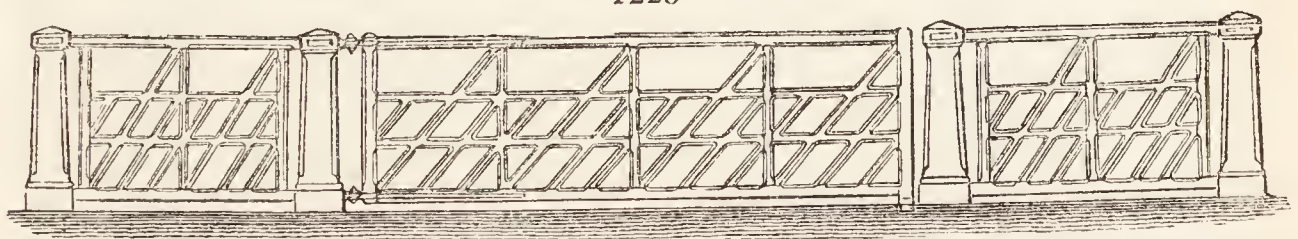
and comfortable for the persons who are to inhabit them.

“ Many instances might be mentioned, in which the tolls on a road have been much increased by building good houses.” (p. 212.) *Fig. 1222.* is the elevation of a toll-house at Llanfair, in Anglesea, built by Mr. Telford.

8246. *Tollgates and bars* should never be placed on the summit of a hill, or at the bottom of one, for obvious reasons. Gates should be painted white, and not made higher than four feet six inches. The width of the carriage-way may be sixteen feet



or more. The toll gates at South Mims, and on the Coventry road (*fig. 1223.*), are hung on “ Collinge’s patent hinges, which are particularly fit for this purpose: they run about five feet along the upper and

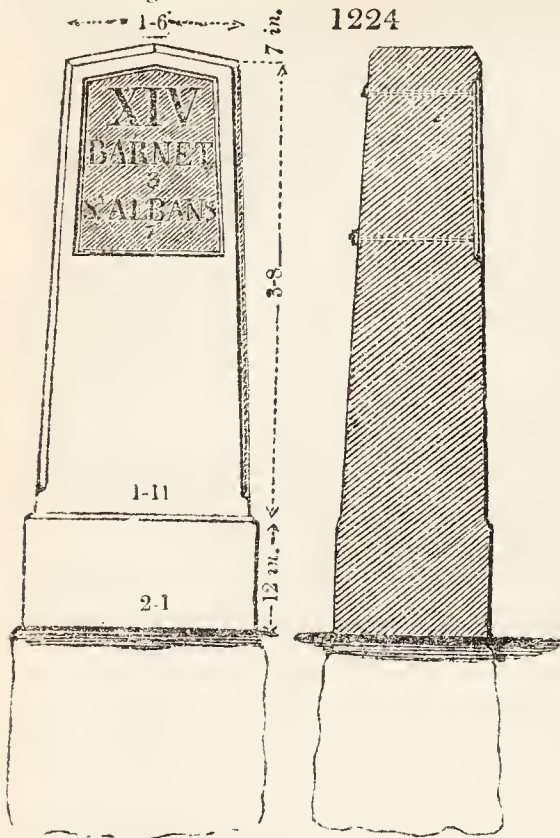


under rail of the gate, and are connected by a diagonal piece of metal, carried from the bed of the lower hinge to the point of the upper one, in order to prevent the gate from sinking. The balls of the hinges are cast, with the caps and plinths of the posts, so that the posts are not weakened by holes or mortises, as in the usual manner of hanging gates. The caps and plinths of metal are also a great security to the posts by preserving them from the effects of the weather, and by preventing the wheels of carriages from chafing their angles.

8247. “ *Flapping-posts* are set in the ground at proper places, to prevent the gates from opening too far, and straining the hinges; these posts are about two feet and a half above the ground, and two feet in it. Catches or clicks are let into these posts, to hold the gates open when thrown back: these catches project about two inches from the side of the posts, and turn on a pin within the post; the inner end of the catch being made heavier than the outer, it always throws that end up, and by that means it takes hold of the bottom of the lower bar of the gate, by a notch cut in it for that purpose: by making the catches in this way, they are out of the reach of injury. In the common way they are put on the top of the posts, from which they project six or seven inches; in consequence of which they are frequently torn off by wheels of carriages and waggons.” (p. 224.)

8248. *Lamps* are required for all tollgates; they should be made similar to the best coach lamps, with powerful reflectors, and large airholes; they may be nine inches high, and six inches wide in the clear

8249. *Milestones* should be made higher than they generally are, and of very hard stone of a light colour. Fig. 1224. is the form used on the Holyhead road.



8250. *Management of roadwork.* As soon as the precise line is determined on, the following circumstances should be attended to: — I. Drawings to show, 1st, the natural surface of the ground; 2d, the longitudinal inclinations of the proposed road; 3d, the slopes of the cuttings and embankments; 4th, the form of the bed of the road, and footpath; and 5th, the courses of materials to be laid on, and the thickness of each course. Drawings should also be made, describing the plans of the bridges, culverts, cross drains, inlets, outlets, depôts, and fences which are required to be made. II. A specification should be prepared, to explain in detail the precise method of executing every part of the work. III. After the specification has been settled, an estimate should be made of the expense to be incurred. IV. Next a contract is to be entered into, which, if the plans, specifications, &c. have been properly made, will be found the most safe and satisfactory mode of execution. Select a contractor of skill, integrity, and capital, and rather overpay than underpay him. V. In preparing a deed of contract, refer to the drawings and specifications, and provide a clause to prevent all deviations from them, except by agreement in writing. VI. Before the work is commenced, an inspector should lay out the work, settle the levels, and see that everything is done agreeably to the specifications. The inspector should be a person of considerable experience as a civil engineer; and it is on the skill of the chief engineer, in engaging men of this kind, that his success in accomplishing great works will very much depend. VII. The mode of paying the contractor should be as the work proceeds: for which purpose it ought to be measured by the inspector every fourth week.

8251. *Improving old roads.* Here nearly the same objects are to be attended to as in making new ones; “such, for instance, as the direction, the longitudinal inclinations, the breadth, form, and hardness of the surface, the drainage, and the fencing. For the purpose of ascertaining in what respect an old road is complete or defective in these points, the following queries have been prepared. The answers that can be given to these will at once show what is the state of a road: —

1st, Is the direction of the road in the shortest line that can be found, without having to pass over steep hills, or other obstacles?

2d, What are the rates of inclination of the hills? Is there no more ascent in the road than is necessary for reaching the heights of the country which must be crossed?

3d, What is the breadth of the road? Is it everywhere the same? Is it defined by side channels, having along them kerbstones, or borders of grass sods?

4th, Are the channels on each side of the road on the same level? Is the convexity of the surface uniformly the same in every part along the whole length of the road?

5th, Is there a footpath? What is the height of it above the side of road? What is its breadth? Of what materials is it composed?

6th, Is there any waste land between the road and the fences of the road? In what state is it?

7th, Is the surface of the road higher than that of the adjacent fields?

8th, Of what materials does the crust of the road consist? What is the depth of them in the centre of the road, and at a distance of five feet on each side of the centre?

9th, Are there sufficient drains for carrying off all rain and other water?

10th, Are the fences low? Are they raised on ground of the same level on both sides of the road? Are they of the same height on both sides, and parallel to each other?

The answers which can be given to these queries will show what the defects are of any road to which they are applied, and what is requisite to be done to improve it.”

8252. *Repairing roads.* This ought always to be managed on a regular plan, more especially with reference to, “1st, The quality of materials. 2d, The quantity to be put on per mile per annum. 3d, The preparation of the materials. 4th, The method of putting them on the road. 5th, The number of labourers to be employed.” (p. 270.)

8253. *The materials used* should always be the hardest; for it has been ascertained by experience, that hard stones brought from a distance are cheaper in the end than soft stones got near the road at a much lower price. It is also a fact, that in proportion to the softness of the stones is the labour of the horses on the road, in working the often-renewed coatings of them into a smooth surface. The best description of stones for roads are, basalt, granite, quartz, syenite, and porphyry. Schistose rocks are rapidly destroyed, more especially when wet; and they occasion great expense in scraping, and constantly laying on new coatings. Limestone is liable to the same objection. Sandstone is very well adapted for the foundation of a road, but much too weak for its surface. Flints vary very much in quality as a road material. The hardest of them are nearly as good as the best limestone; but the softer kinds are quickly crushed by the wheels of carriages, and make heavy and dirty roads. Gravel, when it consists of pebbles of the hard sorts of stones, will make a good road, particularly when the pebbles are so large as to admit of their being broken; but when it consists of limestone, sandstone, flint, and other weak stones, it will not; for it wears so rapidly, that the crust of a road made with it, always consists of a large portion of the earthy matter to which it is reduced. This prevents the gravel from becoming consolidated, and renders a road made with it extremely defective with respect to that perfect hardness which it ought to have.”

8254. *The quantity of materials* to be put on the road in the course of a year will be regulated by their durability, and the traffic on the road. The materials should be quarried, carted, and broken by contract, and, when ready to be put on the road, placed on the depôts till wanted.

8255. *With respect to preparation,* stones should be broken “to a size of a cubical form, not exceeding two inches in their largest dimensions.” Gravel should be sifted at the pits, so that no stone larger than one quarter of an inch in diameter should be carried to the road. The road labourers should again sift it, so as to separate the pebbles that are less in diameter than the rest; and the large pebbles which exceed one inch in diameter should be broken.

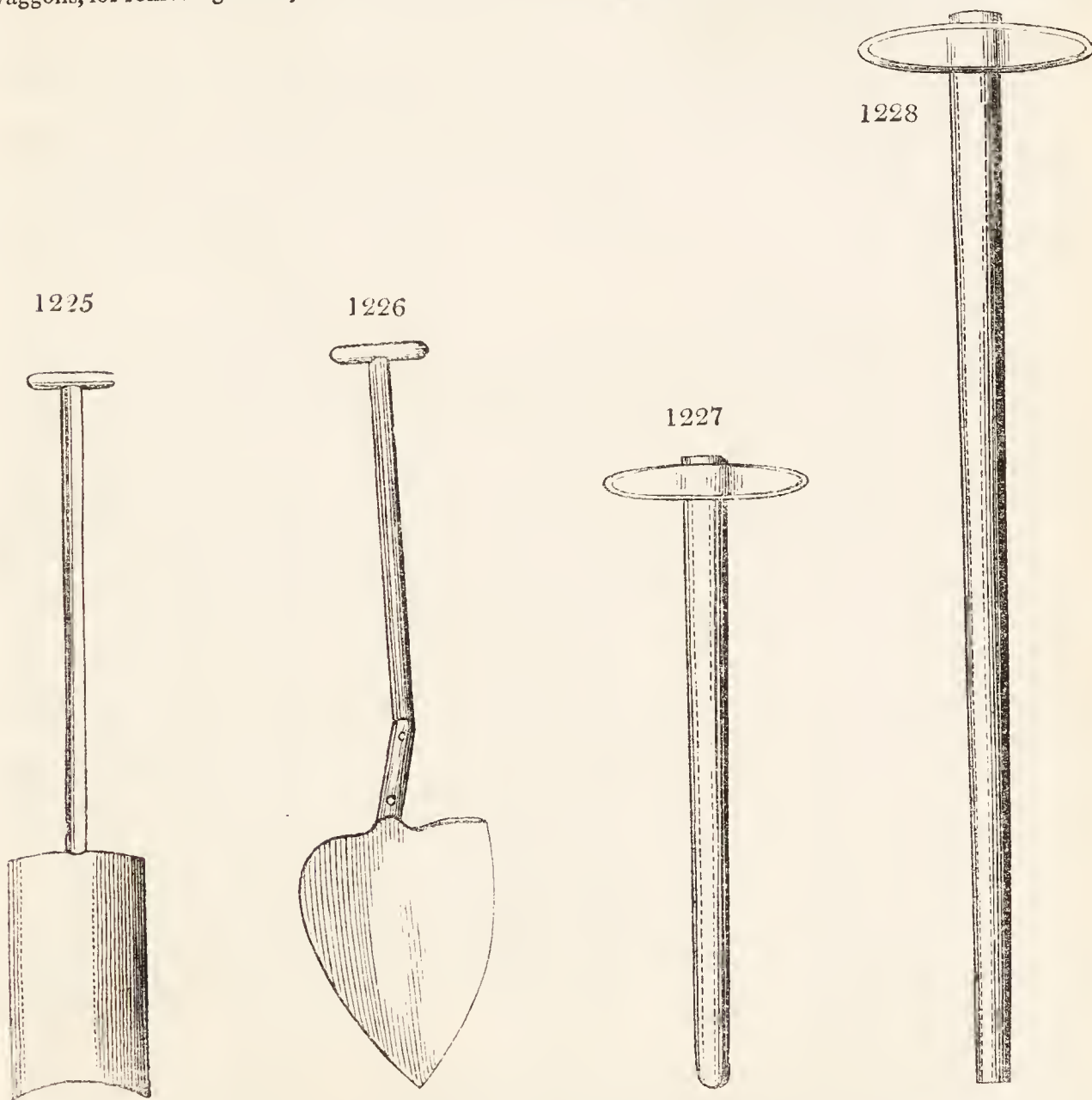
8256. *The materials should be laid on in small quantities at a time,* taking care to fill up ruts or hollows as soon as they appear. “In those places where the surface of the road has become much worn, a coating of one inch and a half of materials should be laid on: that is to say, a coating only a single stone in thickness, when stones are used; and when gravel is used, a coating not exceeding one inch in thickness. If more materials are necessary, they should be laid on after the first coating is worked in. The work of repairing roads, by laying on new coatings of materials, ought to be done between the months of October

and April, and when the surface of the road is wet. By laying on the materials at this season of the year in thin coatings, they are soon worked into the surface, without being crushed into powder, and without producing any great distress to horses drawing carriages over them." (p. 274.)

8257. *In arranging the labourers on a road, it should be divided into "districts of four miles each; and a foreman, with three labourers, should be appointed for each district. The foreman and one or more of the labourers should be daily on the road, taking care that the side channels of the road are kept clean, and making good any injury to the road, as soon as it appears. The foreman should work with the men: he should take care that the orders of the surveyor are attended to, and be able to measure roadwork."* (p. 274.) The water channels and drains should be particularly attended to, and in October in every year they ought to undergo a general repair. At that season, also, the surface of the whole road should be scraped, "all ruts and hollows should be carefully filled with materials, and all weak parts of the surface coated with materials; that is to say, the road should be put, in every respect, into a complete state of repair, so as to preserve it from being broken up during the approaching winter. A road should be scraped, from time to time, so as never to have half an inch of mud upon it. This is particularly necessary to be attended to, when the materials are weak; for, if the surface is not kept clean, so as to admit of its becoming dry in the intervals between showers of rain, it will be rapidly worn away." Hedges should be kept clipped, and branches of trees lopped. The superior condition of roads which cross unenclosed lands, and of those which run south and north, rather than east and west, shows the great benefits of a free exposure to the sun and air.

8258. *The trustees of a turnpike road should require the surveyor to lay before them, at the commencement of every year, an estimate of the work he proposes to perform in that year; and he should make up a monthly account, as well as an annual account.*

8259. *Road instruments and tools.* The principal instruments are theodolites, spirit levels, and sextants, which are used in laying out roads. Road tools are spades, *fig. 1225.*; shovels, *fig. 1226.*; trucks, or small waggons, for removing earth; hammers for breaking stones, *figs. 1227.* and *1228.*, the handles of which should



be flexible, and made of straight-grained ash; the small hammers having a chisel face, and the larger ones a convex one, about five eighths of an inch in diameter. The hammers should be made of cast steel, which wears much longer than wrought iron, and seldom breaks at the eye. Pronged shovels are useful for filling broken stones into carts or barrows: a man will not only lift more stones with them, but he will lift them without taking up earth. Scrapers for scraping off dust or mud should be made of wood shod with iron, or of plate iron, six inches deep, and from fourteen to eighteen inches long. The best scrapers are made of old saw-plates, stiffened on the back by a nib of wrought iron, or a piece of elm board. Hedging-knives are required for trimming hedges, which they do much more expeditiously than shears. Working levels, which resemble a common bricklayer's levels, are absolutely necessary in laying out new works. On the horizontal wooden bar should be placed four gauges, made to move perpendicularly in dovetail grooves, to the lower edge of the bar. Each of these should have a thumb-screw, in order that, when adjusted to its depth below the level line, the gauge may be fixed in the desired position. "Levels for laying out slopes are best made of a bar of wood, three inches deep, one inch thick, and six feet long; on the centre near the middle of the rod, a triangular piece of wood of the same thickness is nailed; the sides of this triangular piece are so formed, that when the rod is placed upon a slope of one to two, or one to three, a small pocket level placed on one side of the triangle will be horizontal, and the bubble will remain in the centre."

8260. *Ring gauges* are required for ascertaining the size of broken stones.

8261. *Road legislation.* The turnpike system is considered as so far good, as, by putting the management of roads into the hands of local proprietors as trustees, a larger road revenue has been raised than the country would have been willing to pay to government for their management. Great errors have, however, been committed in carrying the turnpike system into operation. The government is not to blame for this, because the business has not been in its hands; nor the civil engineers, because they have not been consulted by turnpike trustees. "The country gentlemen of England, in point of fact, are alone responsible for the defective state of the roads, because the business of managing them has been vested, by the legislature, exclusively in their hands." (p. 291.)

8262. *More than double the money necessary is raised,* and the works are performed in the most slovenly manner, or not at all. The trustees on each trust are by far too numerous; they ought to be reduced, and rendered responsible to a board of control, appointed by government. Under such a board, the Holyhead road was improved, and the late Mr. Huskisson, who was chairman of this board, observed, that all the roads in the kingdom ought to be placed under similar control.

8263. *Parish roads* are, in general, much worse than turnpike roads. The private interests of a vestry lead it to be satisfied with very imperfect roads. The surveyor is appointed to act only for one year; a proceeding founded on the vulgar notion that the management of roads is something that requires no education, skill, or science. These roads ought to be managed by county commissioners, as in Scotland. (p. 312.)

8264. *Scotch roads* are superior to the turnpike roads of England. The road management of every county is vested in trustees, which is attended with the following advantages:— "1st, A more efficient governing authority is provided. 2dly, The obstacle to a uniform and efficient management of the roads, which the small divisions of parishes occasion, is obviated by giving the general management of all the roads of a county to the general meetings of the trustees. 3dly, The funds for maintaining the roads are derived from a regular assessment on the lands, instead of statute labour. 4thly, The surveyors are appointed permanently, and with fixed salaries."

8265. *Irish roads* are under the management of grand juries; the defects of which plan is, that the governing authority is insufficient, because it does not represent the interest concerned in road affairs, and because there is a want of "correct moral principle" and "pure habits" among Irish grand juries. (p. 318.) The Scotch, therefore, is recommended to be introduced into Ireland.

8266. *Appendix. No. 1. is a description of Macneill's road indicator,* which Mr. Telford has declared to be, "for practical purposes on a large scale, one of the most valuable that has been lately given to the public." (p. 328.) It may be described as a dynamometer of an improved description, attached to a carriage (a light phaeton), in such a manner that no part of the moving power is communicated to the carriage, except through the agency of the instrument. The indicator may also be attached to the fore part of any carriage, cart, or waggon. Besides pointing out the distance passed over, it marks the power of draught at every ten or twenty yards, and the rates of acclivity or declivity on every part of the road.

8267. *Macneill's road indicator* may be applied to the following important purposes:— 1st, It affords the means of ascertaining the exact power required to draw a carriage over any line of road. 2dly, It can be applied to compare one line of road with another, so as to determine which of them is the best, and the exact amount of the difference, as regards horse power, both for slow and fast coaches. 3dly, The comparative value of different road surfaces may be determined with great exactness. 4thly, It affords the means of keeping a registry, in a most accurate manner, from year to year, of the state of a road, showing its improvement or deterioration, and the exact parts in which such improvement or deterioration has taken place.

8268. *Practical examples explanatory of the foregoing statement.* 1st, Let it be required to determine the expense of working a four-horse coach over the line of road from ——— to ———, at a velocity of ten miles an hour. Suppose the instrument has been run over the road, and that it has been found that the average power required to draw a four-horse coach over the whole line amounts to 350 lbs., and the distance equal to twelve miles. Let the average power which a horse should exert for eight miles a day, with a velocity of ten miles per hour, be assumed equal to 60 lbs.; then $160 \times 8 = 480$ lbs., raised one mile in the day; and taking the daily expense of a horse equal to six shillings, we have 480 lbs. : 6s. : : 1 lb. : .15, the expense of horse power exerting a force of 1 lb. over 1 mile. Thence $350 + .15 + 12$ miles = 630 pence, or 2*l.* 12*s.* 6*d.*, the expense of horse power required to work a four-horse coach per day over such a road.

8269. *The most important and useful application of the instrument* is, perhaps, that of being able to ascertain with accuracy and precision the state of any road, from time to time, as regards its surface; and the state of repair in which it has been kept.

8270. *The public advantages* to be derived from such a system of road inspection would probably be very great. It would show not only where the best plan of repairing roads has been followed, and point out where there are good and bad surveyors, but it would also show if the money of the trust is improperly applied or wasted on any line of road; and it will enable trustees, who let the repairs of their roads by contract, to determine whether or not the contractors have done their duty, and kept the road in the same state of repair as at first, or whether they had improved it, or suffered it to become defective."

8271. *Appendix II. contains a report respecting the street pavements, &c. of St. George's, Hanover Square,* in which the present system of macadamising streets is condemned as in every respect bad.

8272. *Appendix III. is a notice of Mr. Walker's plan of paving roads along the sides,* by which the carmen on footpaths or sides of the roads could be close to their horses without interruption, or being in danger of accidents from light carriages; and the unpaved, being the highest or middle part, would be more easily kept in repair. This plan was adopted in the Commercial Road, Middlesex, in 1820, and has been subject to the heaviest traffic ever since: it has cost very little for repairs, and is now, 1834, in excellent order.

8273. *Appendix IV. Report respecting the expense of the Holyhead and Liverpool roads.* It occupies a number of pages, and will be useful to young engineers, by showing them the forms in which business is transacted, and assisting them in committing their ideas to paper.

8274. *Appendix V. The principal clauses of a Scotch act of parliament respecting roads,* which it is thought might be imitated in English and Irish acts.

8275. *Appendix VI. Tables respecting turnpike road trusts,* extracted from the reports of the Lords' Committee on that subject.

8276. *Note A.* Investigation of the best plan for improving the road through Stowe Hill Valley. By John Macneill. This is a most valuable paper for the young engineer; it contains arguments, comparative views, specifications, and estimates, full of instruction.

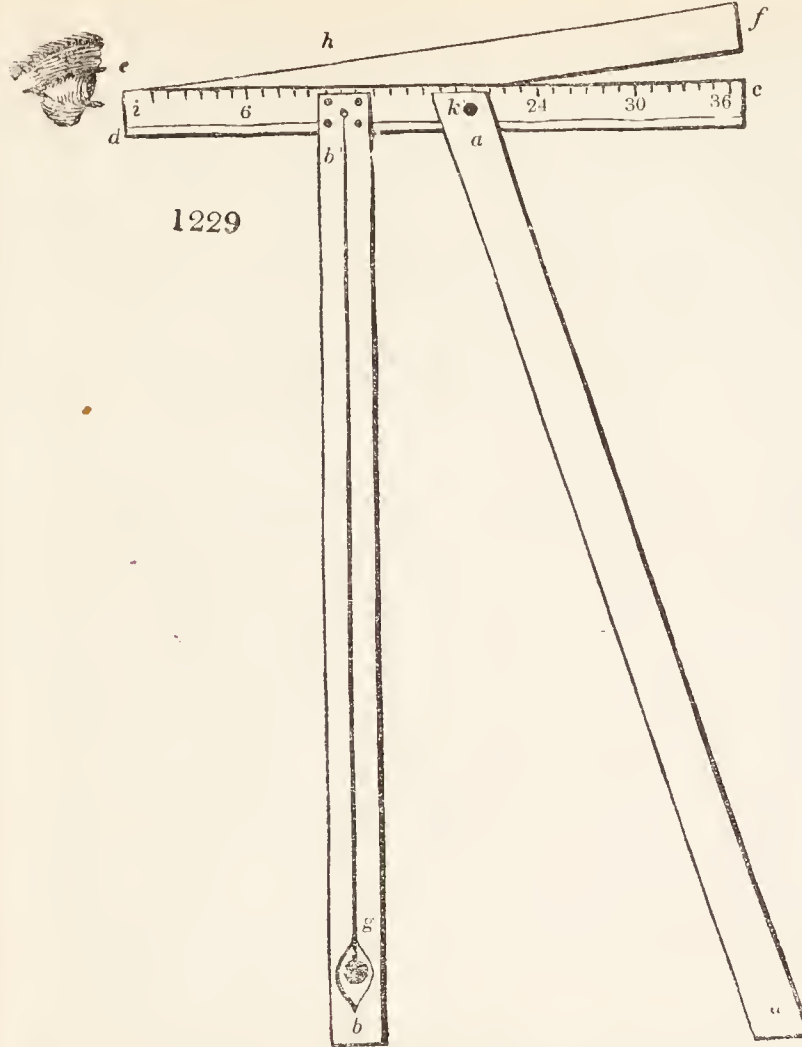
8277. *Note B.* Proofs of the resistance produced by collision.

8278. *Note C.* Proofs of the resistance occasioned by friction.

8279. *Note D.* Proofs of the resistance from the force of gravity, when a road is not horizontal. We have already occupied so much space, that we cannot afford room to give the substance of these notes; but the book itself will soon find its way into the library of every civil engineer, road-maker, and country gentleman. We need hardly say that it is by far the best work on the subject which has appeared in England.

8280. *An instrument for measuring the inclination of roads (fig. 1229.)* is thus described in *Trans. Highland Soc.*, vol. viii. p. 62. :—"A slip of wood must be procured, measuring three inches broad by half an inch thick, and sixteen feet nine inches long, which must be cut into four lengths of five feet three

inches, five feet, three feet three inches, and three feet three inches, marked as follows:—



a a, five feet three inches; *b b*, five feet; *c d*, three feet three inches; *e f*, three feet three inches: six thick screw nails are also required, one inch long. Join *c d* and *e f* by a screw nail, inserted about two inches from the end of each, and exactly one inch from their upper surfaces, as marked *a*. From the point *a*, upon *e f*, draw a line, measuring thirty-six inches, towards *f*, and exactly one inch distant from the upper surface, and divide this line into thirty-six parts or inches. It is self-evident that each of these points, when elevated above *c d*, will show a rise of one in fifteen, twenty, thirty-four, &c., as the case may be, provided *c d*, which should be divided into inches numbered on the upper edge, shall be horizontal; and *e f* shall point to a pole or mark, as high above the ground as *c d* is; this is effected by fixing *b b* firmly upon *c d*, at right angles, and either having a plummet *g* suspended, as in the figure, or a spirit level fixed on the top of *c d*. I prefer the plummet made of bobbin or small cord, with a pierced bullet at the bottom. The instrument is retained in a level or horizontal position by the assistance of *a a*, which is upon a movable pivot, made by one of the screw nails at *b*. The distance of *a a* from *b b* is immaterial. A small stop is fastened at the back of *b b*, for the purpose of preventing *e f* from falling below *c d*. The rise of a road is shown by looking from *e* towards *f*; the fall of a road, of course, by looking from *f* towards *e*, and, if great correctness is required, the observation should be reversed."

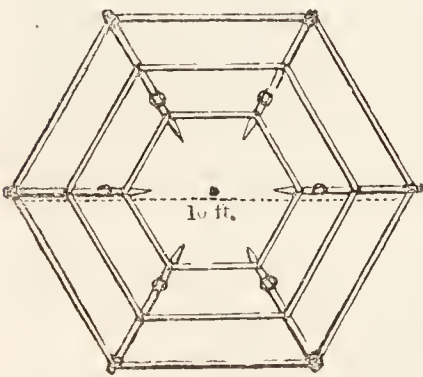
8281.—3862. *Burning of lime, and making of bricks.* A variety of forms of

limekilns, and of kilns for burning bricks, will be found described in the *Encyclopædia of Cottage, Farm, and Villa Architecture*.

8282.—3918. *Succession in the kinds of trees.* "There is reason to fear that a judicious rotation of crops in arboriculture is not, as yet, well understood; doubts are entertained, for instance, that the Scotch pine, as a previous crop, is unfavourable to the growth of larch, having a tendency to produce rot at an early stage of growth. It is well known that the Scotch pine is an excellent preparation for the oak, producing rapid growth where that plant would not previously have prospered, although it may be injurious as a forgoing crop to other resinous plants; and as the Scotch pine and the larch, as a mixture (3958.), are known to prosper tolerably well together without engendering disease from their proximities, it may be inferred that it is not so much from the excrementitious matter exuding from the growing roots of Scotch pine that larch receives injury, as from the poisonous matter, absorbed by the spongioles of the growing larch, proceeding from the decaying roots of Scotch pine in the soil. It therefore becomes a matter of importance for the forester to consider how far it may be advisable to mix larch with Scotch pines in plantations (a practice of frequent occurrence); as, in the process of thinning, a process more or less necessary in every plantation, many roots will be left to rot in the soil, and these, in a state of decomposition, may prove seriously hurtful to living plants on the same spot. It may be safer practice to plant each sort in masses (4012.), observing not to plant larch on an open dry loam, incumbent on a ferruginous subsoil." (A. G.)

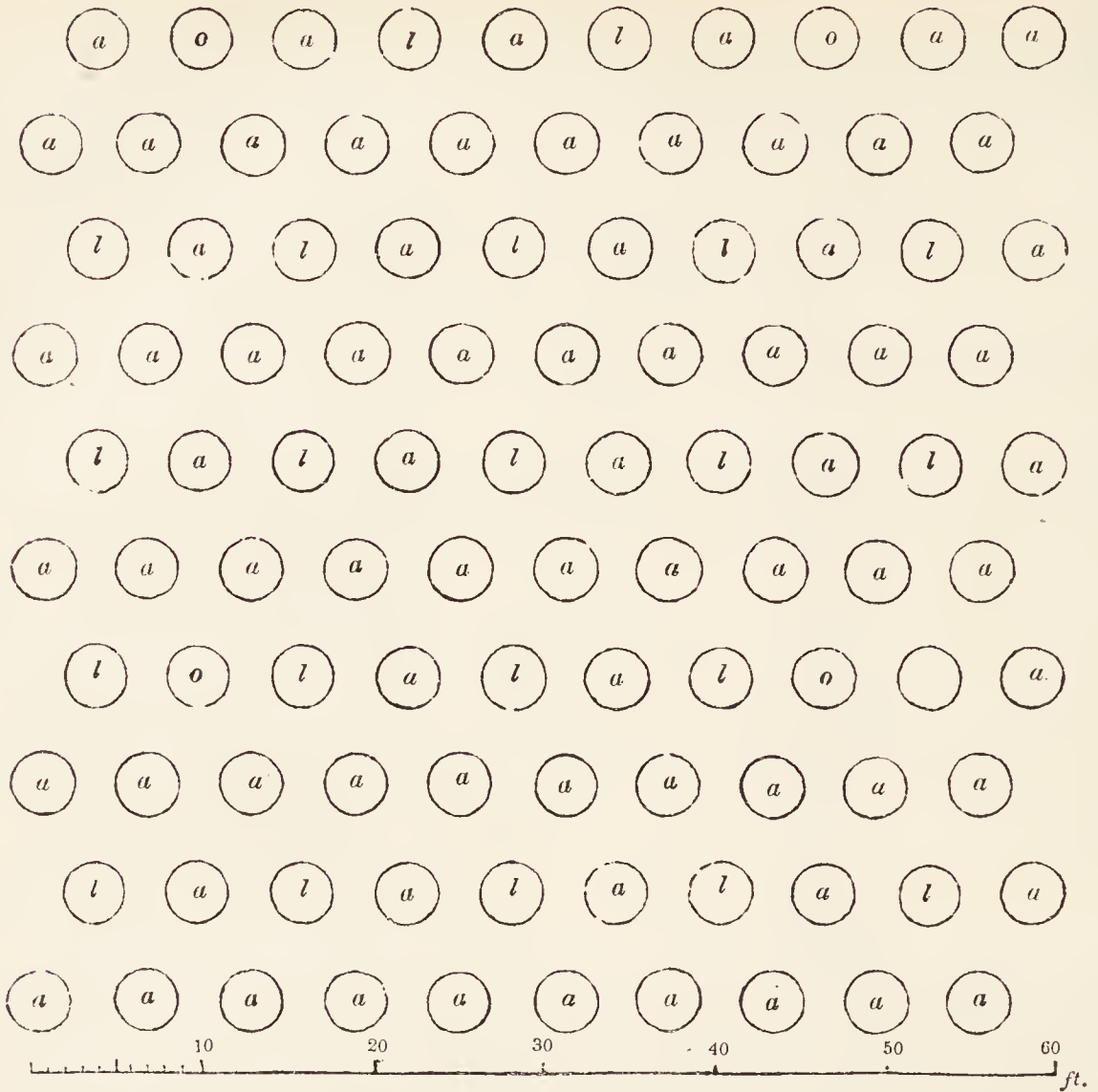
8283.—3923. *A new guard for single trees in parks and in lawns* is described in the *Gard. Mag.*, vol. vi. p. 48. It consists of low stakes with rails nailed to them

1230



in such a manner as to form a hexagonal platform of paling, ten feet in diameter, and about eighteen inches high, round each tree, or group. The advantage is, that it keeps horses and cattle off as effectually as a high paling, and yet is not offensive to the eye. This invention has been termed a dendrophylacton; its vertical profile is seen in *fig. 1230.*, and its elevation, or rather section, in *fig. 1231.*

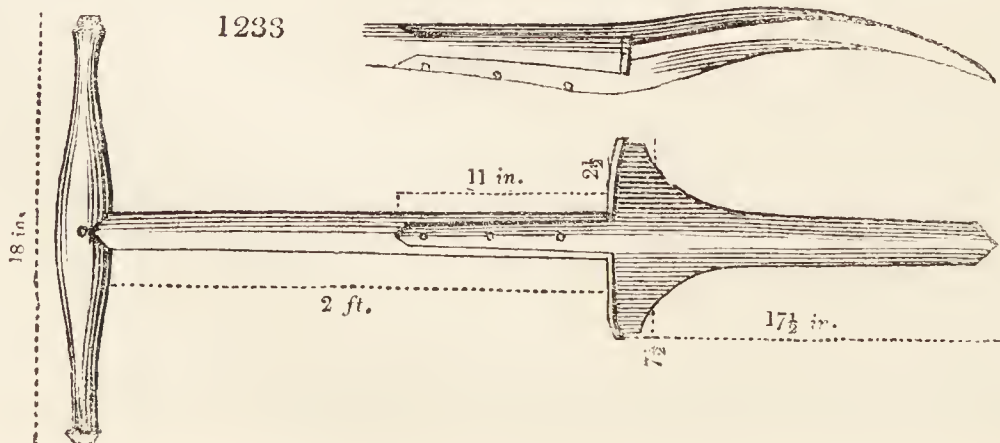
8284.—3928. *Disposing of trees in plantations.* Mr. Lawrence, under ordinary circumstances, prefers a mixture planted at regular distances; and he gives, as an example, a square plantation (*fig. 1232.*), formed of oak, ash, and larch. The great advantage of this regular disposition of the trees, both in regard to distance and kinds, is, that the future management of the plantations can be predetermined, and, as it grows, regulated with perfect ease and accuracy. For example, the trees in this plantation being six feet apart, no thinning will be required until the ash attains a sufficient size for hurdles, hoops, &c., which will be from twelve to fifteen years' growth, according to the quality of the land; or even eighteen years' growth, if the land is very poor. At this period cut off every other ash, in the rows composed exclusively of ash, with a blow in an upward direction, from two to three inches above the ground, in order that the stools should shoot again. The next year cut off all the ash between the larch and the oak in the same manner. The following year cut out the remainder of the ash with a downward blow, under the ground, to prevent them from shooting again. The ash left for stools will produce, in the summer after cutting, several shoots; these should be thinned out, leaving not more than three or four of the best placed for a crop. When these have attained sufficient growth to be crowded by the larch, the



latter will be from twenty to twenty-five years' growth, and should be cut out as soon as the sap is sufficiently in action to admit of their being barked; as, though their bark does not bear a price in proportion to that of the oak, with reference to the tan it yields, it will pay for the stripping. Upon this plan it is obvious that any labourer could effect the necessary thinning without any superintendence: he could not make a mistake. If a variety of timber be desired, a sweet chestnut may be substituted for every other oak, as both thrive well, generally, on the same soil; or any other timber trees may be planted, more suitable to the particular soil, keeping them in the places assigned in the plan to the oak. The underwood may also be varied, by the introduction of the oak, wych elm (*Ulmus montana*), *Sâlix caprea*, hazel, &c., all of which form excellent coppice wood, but they must be introduced in regular order, with reference to future thinning. (*Gard. Mag.*, vol. x. p. 30.)

8285. — 3929. *To grow the best and most valuable timber*, the trees should stand rather closely together, and be regularly pruned, from the time they are five feet high, until a clear stem is obtained of at least twenty feet. Clearness of grain, undeteriorated by knots or flaws, constitutes prime timber; and it is impossible to have it so, unless the trees be carefully trimmed when young. The leading shoot of the stem should always be allowed to have pre-eminence, by cutting off lateral branches which act as rivals; and such branches should be cut off close to the bole, when they are not more than one inch in diameter. If allowed to exceed this size, the wound made by the removal, though it will be shortly afterwards covered with new wood and bark, will always remain a flaw in the timber when cut up for use. Small spray growing on the trunk does no injury to the grain of the timber; and if all branches, as they arrive at the size mentioned, be pruned off, till a bole of sufficient length be obtained, very fine round timber will be the result. It must be remembered, however, that the trunk is not enlarged by pruning, but rather the reverse; but, as length of bole, clearness of grain, and perfect soundness, cannot be had without pruning, and paying attention to the trees in the early stages of their growth, a portion of their girth must be sacrificed for the more valuable properties of length of bole and excellence of timber. (*J. Main, in Brit. Farm. Mag.*, vol. vii. p. 162.)

8286. — 3950. *The perforator* (*fig. 1233.*) is used as a substitute for the spade, in planting young tap-rooted trees in rough ground. It was invented by Mr. Munro of the Bristol Nursery, and, in that



neighbourhood, in 1828, cost about eight shillings. In using it, one man employs the instrument, while another man, or boy, holds a bundle of plants. The man first inserts the instrument in the soil, holding it up for the reception of the plant; round which, when introduced, he inserts the iron three times, in order to loosen the soil about the roots; he then treads down the turf, and the plant becomes as firmly set in the ground as if it had been long planted. Two men may set from five hundred to six hundred plants in a day with this instrument. (*Gard. Mag.*, vol. iii. p. 215.)

8287. — 3954. *The subject of preparing large trees intended to be transplanted by cutting or shortening their roots* has been treated upon, in a very masterly manner, by Mr. M'Nab of the Royal Botanic Garden, Edinburgh, in the *Quarterly Journal of Agriculture*. The following is the essence of the article alluded to: — The practice of cutting the roots of large trees, at a certain distance from the stem, a year or two previous to removal, is excellent, where time is allowed for the operation, or its necessity foreseen; but the opinion, that the chief advantage derived from this operation arises from the formation of young roots, or fibres, is denied. The principal consequence of this mode of mutilation, is the check given to the growth of the tree; by which it is, to a certain extent, stunted. Every large deciduous tree receives a check when transplanted; and, by beginning the operation of checking a year or two before transplanting, it is rendered more gradual.

8288. *The economy of Mr. M'Nab's mode* is thus shown: — “Let three trees of the same kind, and as much alike as possible as to age, size, health, situation, soil, and exposure, be selected, each about three feet in circumference at about a foot from the ground, and from thirty-five to forty feet high. Let a trench, eighteen inches wide, be cut round each, at the distance of eight feet from the stem, and down to the subsoil, so as to divide every horizontal root at the inner side of the trench. Let this trench be left open round the first tree till the period of transplanting, but round the other two let it be filled again with the earth which had just been taken out of it. At the period of transplanting, let the three trees be removed with equal care, and planted in similar situations and soils, the whole operation being conducted in the same manner, with this difference only: in the first, let any new roots which may have formed at the cut extremities, in consequence of earth having accidentally fallen into the trench, be disregarded; in the second, let all the new roots which have formed in this situation be cut off; in the third, let them be preserved with as much care as possible. At the end of two or three years (and we can rarely judge sooner of the ultimate success of our operations), we shall find the whole to have succeeded alike; and it is evident that the first and second will have been removed with a saving of labour, and, therefore, at a cheaper rate, than the last. The length of time which should be allowed to elapse between the cuttings of the roots and the transplantation will vary with the season; after one wet season the trees will be as fit for removal as after two dry years.”

8289. *Two bad methods of transplanting trees* are next described by Mr. M'Nab. By both these methods manure is applied to the roots of the trees previous to their removal. In the one case, the manure or compost is placed in a trench, cut round at three or four feet from the stem of the tree, and by the other it is laid on the surface of the ground all round the stem. Both methods are bad, from their producing an excess of vigour in the tree. By this, the constitution of the tree is brought into an artificial state, and therefore it is much less able to bear the shock of removal, than if it had been left alone. Enriching the soil about trees, after they have been removed, in order to assist them in regaining their previous vigour, is to be recommended; but, if this artificial enrichment is continued many years after transplanting, the tree will be thrown into an unnatural state of growth, which it could not continue without the continuation of the manuring. “There cannot be a doubt that a tree, taken up and transplanted without any previous preparation (even although the roots and branches are deficient), will make a better appearance, at the end of four or five years after removal, than one that has got the top-dressing will do in the same period, supposing all other things alike, both in transplanting and in subsequent treatment. We may be assured that it is a good practice to starve and stunt trees before removal, and to feed and encourage them, for a time, after they have been transplanted.”

8290. *The truth of this doctrine* every gardener has experienced who has been in the habit of taking up plants growing in the open ground and putting them into pots or tubs. If the roots are cut at some distance from the stem some days previous to removal, the plant will receive no great check; but if, on the other hand, a vigorous plant be taken up at once without having its roots previously cut, it will suffer considerably, and, in all probability, lose a number of its leaves, and also its flowers. “Now this difference can only arise from the first plant having been checked in its growth, not from any advantage which it could derive from the formation of young roots between the preparation of the plant and its removal, because the roots are scarcely ever cut so short, at first, as to go into the pot, lest the check should be too sudden, but require either to be shortened a second time, or bent round in the inside of the pot; and, even in this last case, it is hardly possible to preserve any tender rootlets which may have been formed at or near the extremity of the old roots. The principal advantage of following this practice (which I know from experience to be a good one) must, therefore, arise from checking the plant in its growth before it is taken up. Were it necessary, other facts might be adduced to prove that, at least, one great advantage of cutting the roots of large trees previous to removal is derived from the check thus given, and, by consequence, that every measure taken to promote that vigour, previously to removal, must be injurious.” (*Quart. Journ. of Agr.*, vol. ii. p. 828.)

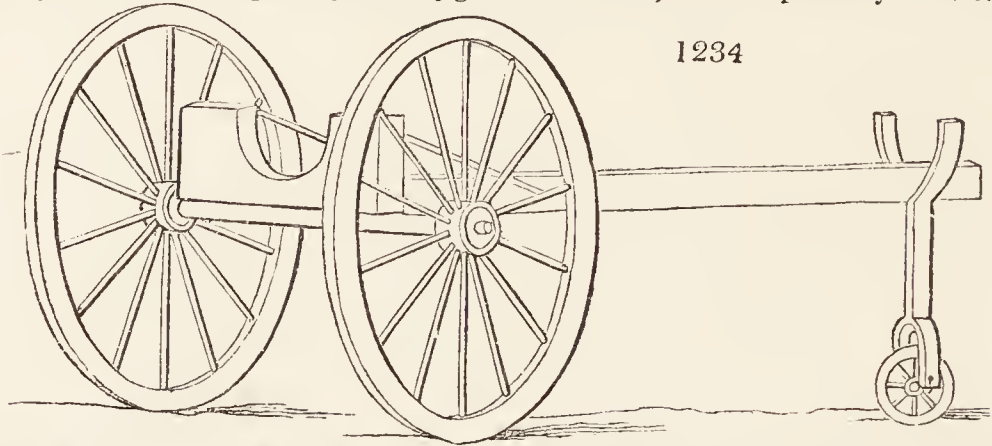
8291. *The practice of Mr. Monro of Brechin* may be adduced as confirmatory of Mr. M'Nab's theory. During the winter of 1824, having occasion to transplant a number of trees, and being dissatisfied with the mode of preparation by opening a trench round the tree and filling it with loose soil, Mr. Monro selected an oak about twenty-five years old, large for its years, and prepared it in the following manner: — He formed a circular trench round the tree, and dug out the earth; but, instead of filling the trench with loose mould, he left it empty, and roofed it over with boards, covering over any opening between them with withered grass, and then putting over the whole one inch deep of earth. The tree remained a year in this state, and was transplanted in the winter of 1825. On reducing the ball of earth to proper dimensions for removing the tree, the old roots were found furnished with fibres, matted sufficiently to retain enough of earth to protect them during removal. The object which Mr. Monro had in view was, instead of encouraging the growth of fibres at the extremities of the amputated roots, as is done when the trench is filled in with loose soil, to have them formed within the ball of earth, and not on the outside of it. This he considered would enable him to remove the tree with a ball, which he never could accomplish by the other method, though he had practised it for five years, on from three to five hundred trees annually. When the trench dug round the tree is filled with loose earth, the young roots form in clusters round the ends of the old roots, and the tree, on removal, generally loses the whole of the earth which forms the ball. (*Gard. Mag.*, vol. ix. p. 218.)

8292. *The opinion of Mr. M'Nab is further confirmed* by the practice which prevails in Belgium and France of planting large trees by the roadside. These trees are always of considerable size, and generally between two and three inches in diameter. When planted out, the head of the tree is cut off, leaving the trunk a bare pole. This bare pole is suffered to grow untouched for one or two years, after which all the branches are cut off below the strongest leading shoot, which is left to form the head of the future tree, and which, in a few years, becomes as straight and handsome as one not headed down, and far more vigorous. (*Gard. Mag.*, vol. ii. p. 226.) The trunks of trees so treated, observes Mr. Joseph Knight, become generally as straight as the mast of a ship, to the height of from thirty to forty feet. (*Ibid.*, vol. x. p. 8.)

8293. *Our opinion on this subject* is, that the mode of previous preparation by digging a trench round the tree, and filling it with rich mould, or by manuring the surface of the soil in which the tree grows, is worse than useless; and that checking the growth of the tree a year before removal, and heading it

down to the height of eight or ten feet, when removed, is the cheapest and best of all modes for general purposes where the trunk of the tree does not exceed from five to eight inches in diameter at the surface of the soil. For larger trees, or for trees which are short-lived, or for any description of tree where immediate effect is an object, we would still do nothing more than check the growth of the tree by cutting its roots a year before removal; and only make this difference after removal, that we would not cut off any, or, at all events, not many of the branches. With regard to trees which may be considered old, in the case of the beech, and in that of all the pine and fir tribe, and of most evergreens, we would cut off no branches whatever. We ground this recommendation as to old trees, the beech, resinous trees, and evergreens, chiefly on experience; it being found that these trees do not bear amputation well, either of their tops or roots.

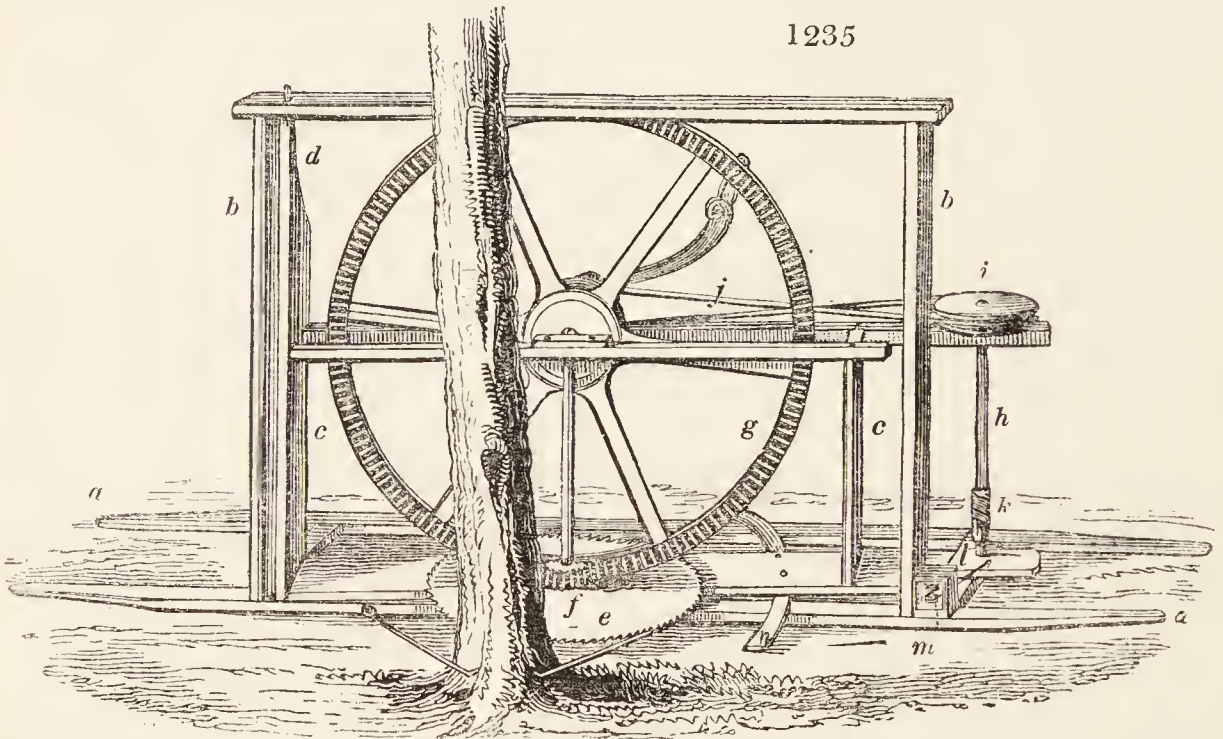
8294.—3957. *The machine for transplanting large trees, in general use in England*, is represented by fig. 1234.; which, after the description given of figs. 592. and 593., will be perfectly understood by inspection.



1234

8295.—3983. *Filling up blanks in plantations.* In Cambridgeshire, where the willow is grown extensively for basket rods, deaths take place occasionally among the stools. The mode of filling up the blanks thus occasioned is not, as might be supposed, by sticking in a cutting, as in the case of new plantations, because the shoots from that cutting would soon be choked by the surrounding shoots from the stools; but by inserting a rod at its full length, and allowing it to grow undisturbed for a year or two; when, having acquired an abundance of roots and a thick stem, it is cut down. Empirical practice is here in beautiful accordance with science. (*J. D.*)

8296.—4062. *Sawing machines for felling timber*, of four different kinds, will be found described in the *Highland Soc. Trans.*, vol. ix. p. 275. The most powerful of these appears to be a circular saw (fig. 1235.)



1235

which consists, first, of a ground frame (*a a*), in form of the common hand-barrow, eight feet and a half in length by two feet and a half in width; on one side of which is erected a vertical frame (*b b*), of three feet and a half in height. The second compartment comprehends a traversing frame or carriage (*c c*) about five feet in length, and two feet in height; the vertical bar (*d*) being prolonged upward, and having its top and bottom ends formed into pivots, on which the carriage, carrying all the working machinery, is made to swing. The saw (*e*), of twenty-four inches diameter, is fixed on the lower end of a vertical spindle, and immediately above it a bevelled pinion (*f*), which is driven by the wheel (*g*); the winch handle, by which the power is applied, is fitted upon the same spindle. The saw pinion and the wheel (*g*) are in the proportion of one to five, so that, when the handle is turned with the ordinary velocity of forty revolutions a minute, the saw will make 200 revolutions in the same time. In order to keep the edge of the saw in contact with the saw-draft, a vertical spindle (*h*), carrying the pulley (*i*), of one foot in diameter, is placed at the outward extremity of the carriage; the pulley (*i*) is put in motion by the band (*j*) passing over a smaller pulley on the winch axle. On the spindle (*h*) there is also fitted a small drum (*k*), capable of being disengaged at pleasure from the motion of the spindle by means of a clutch. The cord (*l*), which passes round the pulley (*m*), in the ground frame, has one end attached to the carriage; while the other end, being attached to the drum, is coiled upon it when revolving along with the spindle, thereby carrying forward the saw with a slow and uniform motion. When the operation is completed, the small drum is disengaged, and the cord is allowed to uncoil, while the carriage is moved backward to prepare for the next cut. For the support and guidance of the carriage, an iron segment (*n*) is fixed upon the lower part, which slides through eyes in the ground frame; and the machine is kept steady while at work, by two iron dogs (grappling irons), the hooks of which are driven into the roots of the tree. The certificates accompanying the model of this machine bear ample testimony to its successful application on the large scale; and show that it can be worked, and carried from tree to tree, by two men. The machine here described is calculated for felling trees from eight to twelve inches in diameter. (*Highland Soc. Trans.*, vol. ix. p. 276.)

8297. *Species and varieties of the larch.* That extensively cultivated by the Duke of Athol is the common white larch, *Làrix europæa Dec.*; but the following other species or varieties were tried:—
 1. The Tyrol larch, with white flowers; those of the common variety being pink flowers. 2. The Tyrol larch, with white flowers; the cones also remarkable for their whiteness, and for being erect, not cernuous. The shoots of the Tyrol larch are generally stronger than those of the common larch; but the foliage of both kinds is similar. 3. The weeping Tyrol larch, a variety of the common, with pendulous branches; but distinct in botanic characters from the *Làrix pëndula*, or black larch of North America. 4. The red larch of North America, or *Làrix microcarpa*. This species is remarkable for the great specific gravity of its wood, which is so ponderous that it will scarcely swim in water. Its cones are shorter or smaller than those of the common larch, its branches weaker, and its leaves narrower. 5. The Russian larch, raised from seed procured by the Duke from Archangel, about the year 1806. The bark is cinereous, not yellowish-brown; the leaves come out so early that they are liable to be injured by spring frosts. The *Làrix pëndula*, or black larch of North America, and *Làrix dàrica* of Dr. Fischer of Petersburg, are distinct species, no examples of which exist at Dunkeld or Blair. (*Hort. Trans.*, vol. iv. p. 416.)

8298. As an *Appendix* to the chapter on Planting, we shall here give some account of the larch plantation of Athol and Dunkeld, from the *Transactions of the Highland Society*, vol. xi. p. 165. to p. 219. It appears that the late Duke of Athol planted 15,573 acres, which contained 27,431,600 plants. Of these 8,604,542 plants were larch. All these were planted in the slit manner, as by far the best. It is stated in that paper that the larch will supply timber fit for ship-building, at a great height above the region of the oak; and that, while a seventy-four-gun ship would require the oak timber of seventy-five acres, it would not require more than the timber of ten acres of larch; the trees in both cases being sixty-eight years old. The larch in the neighbourhood of Dunkeld grows at the height of 1300 feet above the level of the sea; the spruce at 1200; the Scotch pine at 700; and deciduous trees not higher than 500. The larch, in comparison with the Scotch pine, is found to produce three and three quarter times more timber, and that timber of seven times more value. The larch, also, being a deciduous tree, instead of injuring the pasture under it, improves it. It is remarkable that the woolly aphid, which affected the larch plantations in most parts of Scotland for a number of years about the beginning of the present century, never extended higher than about 600 feet above the level of the sea. The late Duke John the Second planted, in the last years of his life, 6500 Scotch acres of mountain ground solely with the larch, which, in the course of seventy-two years from the time of planting, will be a forest of timber fit for the building of the largest class of ships in his majesty's navy. It will have been thinned out to about 400 trees per acre. Each tree will contain at the least fifty cubic feet, or one load of timber, which, at the low price of 1s. per cubic foot, only one half of its present value, will give 1000*l.* per acre, or, in all, a sum of 6,500,000*l.* sterling. Besides this, there will have been a return of 7*l.* per acre from the thinnings, after deducting all expense of thinning, and the original outlay of planting. Further still, the land on which the larch is planted is not worth above 9*d.* to 1*s.* per acre. After the thinnings of the first thirty years, the larch will make it worth at least 10*s.* an acre, by the improvement of the pasturage, upon which cattle can be kept summer and winter. (*Highland Soc. Trans.*, vol. iii. p. 168.)

8299. *Soil for the larch.* It is an error to suppose that the larch will thrive in all soils and in all situations. There are many kinds of soils in which it will not thrive, and ought not to be planted. It has been found that, in soils which have been turned up by the plough, and which have borne white crops, the larch cankers. It cankers in wet situations also. In soils resting on a wet tilly subsoil, it decays at the heart, after arriving at forty years of age. In situations where water stands for a length of time about the roots, it becomes fogged, or covered with lichens. But in all rocky situations, and particularly those which are composed of mica slate, containing crystal of garnets, among the fissures and fragments of which they can push down their roots, larches thrive to admiration. The geognostic character of the country from Dunkeld to Blair is primitive. At Blair is gneiss, at Dunkeld clay slate, and the intermediate space is occupied by mica-slate: they lie conformably to one another.

8300. *Situation.* The advantages resulting from planting mountain ground appear at first sight, in the greater number of trees that may be supported on the acclivity of a mountain than on a surface equal to its base. Trees derive nourishment from the soil immediately around the place in which they are fixed; and, as the superficies of that soil must, of course, be greater on an acclivity than on the base, a greater number of trees will be there supported. Practically speaking, 100 trees, at six feet apart, can be planted on the hypotenuse of a right-angled triangle, whereas the base would only permit eighty at the same distance. Another and a great advantage derived from planting mountain ground is, that, on an acclivity, the trees expose a greater surface to the influence of the sun, and air, and rain, than they can do on a level surface. That trees derive much nourishment from the air, through the instrumentality of their leaves, there is no doubt. The experiment of taking the bark from fifty standing larches, in May, 1814, at Dunkeld, did not prevent their vegetation, and even forming wood for two years after. The outside trees in a forest are always the strongest. On an acclivity, they all possess the advantages of outside trees; and, at the same time, most of the shelter enjoyed by those in the interior." (*Highland Soc. Trans.*, vol. xi. p. 185.)

8301. *Nurses* were not used by the late duke in his larch plantation. The gardener, in the Duke's absence, planted some acres with a mixture of Scotch pine and larch; but so far were the former from nursing the latter, that at the end of seventeen years they had not attained a height exceeding three feet; while the larches which they were intended to nurse were from fifteen to twenty feet high.

8302. *The growth of the larch.* Taking the average height of an average larch, of eight years from the seed, at eleven feet, it will be nearly accurate to allow sixteen inches as the annual growth, till the tree is fifty years old, and after that only ten inches per annum for twenty-two years longer; as the length of the tree lessens in growth as the bulk of the wood increases. These data give a larch tree of seventy-two years of age a height of ninety-three feet four inches; a fair average, agreeing with actual experiment. The shoots of larches beyond thirty-five years of age are heavier, though they are not so long as those of younger trees. The larch, like the oak, puts forth two shoots every year, the one in spring, the other in autumn. The spring shoot has no lateral branches; the autumnal shoot pushes out like the spring one; but, at the time this process is going on, the spring one is throwing out lateral branches which are firm and woody.

8303. *In regard to the growth of the girth*, a larch tree, on an average, will acquire an inch in girth per annum, till it be twenty-four years old; and, from that time, till it has acquired the venerable age of seventy-two years, it will grow one inch and a quarter in girth every year; thus:—

In 24 years, it will be 2 feet in girth, at 1 inch per annum.
 48 years more, 5 feet in girth, at 1½ inch per annum.

—
 In 72 years, it will be 7 feet.

8304. *The larch begins to make wood* at twenty-four years of age.

At 50 years old it will contain 26 cubic feet of wood.
 60 ————— 14 ditto more.
 72 ————— 20 ditto more.

—
 In all, 60 ditto, or one load of 50 cubic feet, and 10 feet more.

8305. *These results* correspond exactly with the quantities which the Duke obtained at these respective ages. Larch appears to be on its greatest increase for timber from fifty-seven to seventy-two years old. A larch containing fifty cubic feet, or one load of timber, is quite fit for naval purposes. At half that size it is suitable for every country purpose.

8306. *Thinning larch plantations.* The great object of the Duke, in planting the larch, seems to have been to raise timber for naval purposes; and, finding that larches grow to a great size at only twelve feet apart, he thinned accordingly. This distance gives 380 trees to the Scotch acre, or about one fifth of the 2000 originally planted. "The first thinning should consist of a light one of about one fifth of the whole, by removing only those trees that are of least value or worthless. After twenty-four years from the time of planting, the spines fall off the lower branches, which are, of course, no longer useful to the soil below. From twenty to thirty years old, then, the thinning is carried on so extensively, as to remove two thirds of that which was left standing by the first thinning. In thinning, it is necessary to observe that all the strongest and healthiest trees should be left, even if two or three of them should be closer together than twelve feet. These small clumps happening to light on a favourable situation, they will thrive well, as the air has access to each tree, around two thirds of its circumference. This thinning being delayed so long, the trees thinned out will be valuable for a variety of purposes. One of these purposes is the profitable use which may be made of the bark. The last thinning should be given when the trees are from thirty to thirty-five years old, which will leave from 380 to 400 trees per acre."

8307. *Pruning the larch.* Little or no pruning was used in the larch plantations at Dunkeld. The 380 trees left in the acre, it is observed, "will require a little pruning and trimming of the lower branches, in order to give head room to the cattle, which are to browse on the grass below. The whole prunings and thinnings will cost about 5*l.*, and their produce will fetch about 12*l.*, leaving a profit on them of about 7*l.* an acre." (*Highland Soc. Trans.*, vol. xi. p. 190.)

8308. *Thin planting the larch* is recommended by the late Duke of Athol, because it allows the lower branches to extend to a greater size; and on these depend the thickness of the base of the trunk of the tree, and the strength of its roots. He therefore seldom planted more than 2000 plants per acre, more especially in elevated regions.

8309. *The process of the thickening of the soil, and the improvement of the pasture, by the larch*, being very important in its results, it deserves to be particularly described. The lower and stronger branches meet together in six or seven years after planting, so as to form a complete matting over the ground. The air and light being excluded by them, all plants that are under them die. At the same time, the annual deposit of leaves from them, by means of decomposition, forms, in the course of time, a soil of considerable depth. At the age of twenty-four, the larches lose the spines on the lower branches altogether, and that is the natural mark of their being ready to be removed by thinning, to a considerable extent. On the air being readmitted by the removal of the trees, the surface of the new-made soil, wherever it has been formed, even among the rocks, becomes immediately covered with natural grasses, of which the *Hólcus móllis* and *H. nátus* seem to predominate. These grasses continue to grow, and to thicken into a sward by the annual top-dressing which they receive from a continued deposition of leaves. The improvement of the natural surface of the ground for pasturage, by means of the larch, appears to be a property peculiar to this tree. This pasturage is quite capable of improving the condition of cattle either in winter or summer.

8310. *With regard to other trees effecting a change of the ground*, the following are the results of many experiments made by the Duke on the subject. In oak copses, the value of the pasture is only 5*s.* or 6*s.* per acre for eight years only in every twenty-four years, when the copse is cut down again. Under a Scotch fir plantation, the grass is not worth 6*d.* more per acre than it was before it was planted. Under beech and spruce it is worth less than it was before; but the spruce affords excellent shelter to cattle, either from the heat of summer or the cold of winter. Under ash the value may be 2*s.* or 3*s.* per acre more than it was in its natural state. But under larch, where the ground was not worth 1*s.* per acre, the pasture is worth from 8*s.* to 10*s.* per acre, after the first thirty years, when all the thinnings have been completed, and the trees left for naval purposes, at the rate of about 400 to the acre, and twelve feet apart. Nay, so impressed was the Duke of the value of larch as an improver of natural pasturage, that he makes a statement to show that the pasture alone, independent of the ship-timber on it, would increase the value of land, by increasing its annual rental, so that it itself would repay the whole outlay of fencing and planting, at five per cent. compound interest, thus:—

3000 acres of land in its natural state, not worth above 1 <i>s.</i> per acre, at 25 years' purchase,	£	s.	d.
will give	-	3,750	0 0
Plants and planting, at 6 <i>s.</i> per acre	-	900	0 0
2400 rods of fencing, at 5 <i>s.</i> per acre	-	600	0 0
Sundry expenses, at 3 <i>d.</i> per acre	-	37	10 0
		<hr/>	
		£5,287	10 0

5287*l.* 10*s.*, at five per cent. compound interest, for twenty-nine years, the period at which the land is fit to be begun to be depastured, gives 21,150*l.*; but 3000 acres, at an improved rent only of 6*s.* per acre per annum, at twenty-five years' purchase, yield 22,500*l.* (*Highland Soc. Trans.* vol. xi. p. 189.)

8311. *The value of larch wood*, exclusive of the value of the pasture under it, may be estimated in this manner:—Suppose the plantations are thinned out by thirty years to what they are to stand for ship-timber; that is, to 400 trees per Scotch acre;—suppose, after that period, the whole were cut down at the following respective ages; the value of the whole, per acre, at the different periods, would be as follows:—

400 trees at 30 years old, at 2½ cubic feet each tree, = 1000 cubic feet, or 20 loads, at	£	
1 <i>s.</i> 6 <i>d.</i> per foot profit, =	-	75 per acre.
400 trees at 43½ years old, at 15 cubic feet each tree, = 6000 cubic feet, or 120 loads,		
at 1 <i>s.</i> 6 <i>d.</i> per foot profit, =	-	450 —
400 trees at 59 years old, at 40 cubic feet each tree, = 16,000 cubic feet, or 320 loads,		
at 2 <i>s.</i> 6 <i>d.</i> per foot profit, =	-	2000 —
400 trees at 72 years old, at 60 cubic feet each tree, = 24,000 cubic feet, or 480 loads,		
at 2 <i>s.</i> 6 <i>d.</i> per foot profit, =	-	3000 —

The average of these prices would be 1381*l.* 5*s.* per acre; so that 1000*l.* per acre is not too high a calculation of the value of the Duke's larch plantations.

8312. *On felling large trees of larch*, care must be taken to use plenty of rope, and to take advantage of the direction of the wind; but a very windy day should be avoided. It was found, in digging the Scotch fir out by the roots from among the larch, that the ground was so much shaken about the roots of the larch, as to endanger their stability: ever after, the fir was cut over by the ground.

8313. *The seasoning of larch timber* is accelerated by stripping off the bark before felling. In May, 1815, the Duke experimented on fifty trees of larch at Dunkeld, that were growing in a situation, among other wood, that was nearly inaccessible for want of a road or path to it. In 1816 they were cut down and used for several purposes, and they appeared to be completely seasoned. They contained twenty-five cubic feet of wood each. Larch trees that had been only ten months cut down were built into a steam-boat in the river Thames, but they had not been seasoned enough, as the planks above water, near the deck, shrunk a little. In this case, however, the scantlings were made the same as of oak, which were of too slight dimensions for larch.

8314. *Uses of the larch.* These are very various. Larches have been grown by the Duke as nurses to spruce firs. The thinnings of larch plantations, "which take place from twenty to thirty years of their age, supply useful materials for various purposes. Posts and rails for fencing may be made either out of the tops or the trunks of young trees. While fir-posts and rails last only about five years, and are worm-eaten after that period, the larch-posts stand for twenty years, and never get worm-eaten.

But the trunks of young trees are preferable for this purpose to the tops, as they have less sap-wood. In 1807 the Duke fenced a nursery-ground with young larch trees cut up the middle, made into a railing seven feet high. In three years after, the sawn side assumed a leaden grey colour, and in 1817 the whole railing was quite sound. Larch tops which had lain cut for four years, and were, of course, well worn, were found useful in filling drains where stones were at a distance, and they continued sound in them for many years. The larch was used for axles to different kinds of mills, from 1793 to 1802, and up to 1817 they continued quite sound, though constantly in water.

8315. "For buildings, too, the larch is found equally desirable. In 1779, the Duke built the shooting-box in Glentill, called Forest Lodge, the floors and joints of which were made of larch. The wood was under forty years old, and, as an experiment, some of the deals were cut up narrow, and others as broad as they could be wrought. In 1817 the narrow boards continued quite close together. After the bridge was thrown over the Tay at Dunkeld, the Duke altered the course of the great northern road to Inverness, which caused him to build a new porter's lodge, stables, and offices to Dunkeld House, near the new line of road. The whole wood-work of these buildings was executed with larch. They were finished in 1812. In 1813, part of Athol House was burnt down, and the repairs of wood, consisting of joists, floors, doors, and windows, were all made of larch. This wood was so red in colour that it looked like cedar. Several houses were also repaired in the town of Dunkeld with larch. At Dunkeld 271, and at Blair 170, larch trees had been used by 1817 for building purposes.

8316. "The first attempt to use the larch for the purposes of navigation was in the construction of fishing-cobles on the Tay in 1777. In 1809, 8491 cubic feet of larch timber were sent to Woolwich dockyard. The greatest quantity which was employed was in the repair of the *Scrapis* store-ship, and the state of its soundness was favourably reported on in 1817. One beam of it was put into the large frigate *Sibylle*, in 1816, after it had lain six years in the dockyard. The next trial of larch in shipbuilding was in the *Sir Simon Clerk*, merchant vessel, of 375 tons register, built by Messrs. Symes and Co. of Leith, in 1810. They got eleven trees, containing 1066 cubic feet, and they were formed into the first four or five planks, of three inches and a half in thickness, on the bottom of the vessel from the keel upwards. This vessel was soon afterwards taken by the Americans, and no account could therefore be got regarding the durability of the timber."

8317. *The elasticity, durability, strength, and resilience of larch timber, relatively to oak and Baltic fir*, has been determined by experiment. The details, in a tabular form, will be found in the article quoted; and the following are the general results:—The Riga timber and American white pine are about one fifth part less strong than the larch. The larch is superior to the oak in stiffness, in strength, and in resilience, or the power of resisting a body in motion; and it is inferior to Memel or Riga timber in stiffness only. The larch tree, while growing, may be uprooted by wind, but it seldom breaks over by the stem, either by wind, or a weight of snow lodging on its upper branches. The durability of the timber, in every stage of its growth, is superior to every other, even to oak itself. When speaking of all the above properties as belonging to the larch, it is always to be understood to be grown in an alpine region on dry soil. In low rich soils the wood is of a very inferior character.

8318. *The large roots of larch trees fit for ship timber* may be used as knees; and this was first done at Leith in 1811. These roots have been used for the same purpose on various occasions since that time.

8319. *The larch has been tried for masts*; but, the vessels which were fitted up with them having left the Tay, it is uncertain how far larch timber will answer for that purpose. It was the Duke's practice "to plant spruce in all the wet parts of the ground, which he planted to the amount of about one tenth, expressly for the purpose of raising masts and spars, for which he conceived the spruce peculiarly well adapted."

8320. *The larch as piles*. Two hundred and twenty-three trees, forty-two years old, were converted into piles, and driven into the river Thames in the front of the works of the Woolwich dockyard in the year 1810. A report on their state was made in 1817, when they were found to be as fresh as when they were driven in. It is impossible to peruse this paper without being strongly impressed with the patriotic views entertained by John, the second Duke of Athol. Living in a period when the country was involved in a war with almost all other countries, he dreaded, in common with other patriots and statesmen, a scarcity of timber fit for naval purposes, and he contemplated the idea of planting so extensively as to provide against this scarcity for centuries to come. In all his plans and operations we see little or nothing of the merely selfish principle at work; his great object was to provide a regular yearly supply of ship timber, the commencement of which supply could not take place till many years after he was dead. The following table shows the Duke's own calculation of the supply which would be afforded by the woods of Athol, from 1832 to 1904.

12 years cutting from	1832 to 1844 will give	1,250 loads annually from	50 acres.
10	1844 - 1854	8,000	300
8	1854 - 1862	18,000	650
8	1862 - 1870	30,000	1050
16	1870 - 1886	52,000	2000
18	1886 - 1904	120,000	3000

8321. *The relative duration of timber* has been thus determined by M. Hartig, an eminent German professor of forestry. Small posts of lime tree, black American birch, alder, and trembling poplar, inserted in the soil, decayed in three years; the common willow, horsechestnut and the platanus in four years; the purple beech and the common birch in five years; the elm, the hornbeam, the ash, and the Lombardy poplar, in seven years; the acacia, the oak, the Scotch pine, the Weymouth pine, and the spruce fir, at the end of seven years were only decayed a little to the depth of a quarter of an inch; the larch, the common juniper, the Virginian juniper, and the arbor vitæ, were, at the end of the same period, untouched by decay. Thin boards of the same woods decayed in the following order: platanus, horsechestnut, lime tree, poplar, birch, purple beech, hornbeam, alder, ash, the maple, the spruce fir, the Scotch pine, the elm, the Weymouth pine, the acacia, the oak, and the larch. (*L'Agronome*, tom. i. p. 315.) It thus appears that the larch, whether as posts with the bark on, or sawn up into boards, is by far the most durable of our timber trees.

8322. — 4138. *Machinery and utensils necessary for cider making*. In the *Encyclopædia of Cottage, Farm, and Villa Architecture* this subject is treated at much greater length; and not only all necessary plans, elevations, and sections are given, but detailed specifications for the execution of the work, and detailed estimates of the cost of every part.

8323. — 4267. *The frequent-drain system*. The great importance of thorough drainage, and deep ploughing, has lately been placed in a striking point of view, by James Smith, Esq. of Deanston, in Stirlingshire, in an article contained in a *Report of the Exhibition of Agricultural Productions, &c.*, published, in 1832, by Messrs. Drummond, seedsmen, of Stirling. Mr. Smith observes, "that the practical drainers of the old school cannot see how a field should be drained, unless by deep cross drains, to cut off the springs. The portion of land, however, wetted by water springing from below, bears but a very small proportion to that which is in a wet state from the retention of the water which falls upon the surface in the state of rain; and a vast extent of the arable land of Scotland and England, generally esteemed dry, is yet so far injured by the tardy and imperfect escape of the water, especially in winter, and during long periods of wet weather in summer, that the working of it is often difficult and precarious; and its fertility is much below what would uniformly exist under a state of thorough dryness. A system of drainage, therefore, generally applicable, and effecting complete and uniform dryness, is of the utmost importance to the agricultural interests, and, through them, to all the other interests of the country. By the system here recom-

mended, this is attained, whilst the expense is moderate, and the permanency greater than on any other system yet known. The drains, as applied in the carse, have been named *wedge drains*, from their form, and being filled with wedges or keys to preserve the opening in their bottoms. They are sometimes called *furrow drains*, from their being placed under the water furrows of the ridges; but these terms give no exposition of the principle upon which the effect of this mode of draining depends. The principle of the system is, *the providing frequent opportunities for the water rising from below, or falling on the surface, to pass freely and completely off*; and, therefore, the most appropriate appellation for it is *the frequent-drain system.*"

8324. *Main drains.* In proceeding to apply this system of drainage to land, the first object is to obtain a sufficient fall, or level, as it is commonly termed, for a main drain to receive the water flowing from the various smaller or ordinary drains. This drain should be directed along the bottom of the chief hollow or valley of the grounds, where the whole or greater portion of the drains can be led into it. If any lesser hollows occur in the extent of surface, they must also have their proportional mains or leaders. The bottom of the main should be at least three feet; and, if possible, three feet and a half or four feet under the surface where it passes along; and it should have throughout as uniform a fall as the nature of the ground will admit. It should be flagged at the bottom; or, where flagstones are expensive, built as an inverted arch, to prevent the possibility of rain, &c. washing away the earth under the side building. The dimensions necessary will depend on the fall or declivity, and the area of land from which the drain has to receive water. With a fall in no place less than 100 yards, a drain ten inches wide, and eighteen inches deep, will receive the rain water from 100 acres. It is of great importance to make the openings of such drains narrow and high; as they will thus require smaller bottoms and covers, and be less liable to give way; the current of water being also more confined, mud and sand will be less apt to settle in the bottom. Let the sides be smoothly and securely built with flat stones, either with or without mortar; and let strong flat covers be placed over the drain; or, where such are not to be found, a rough simple arch, with thin stones and mortar, may be built, packing the haunches of the arch well up to the sides of the cuts with earth beaten in firmly. Where lesser hollows occur, crossing the fields, it is necessary to cut submains along their bottoms, about three feet or three and a half feet deep, and having openings of suitable dimensions formed by stone couples (two flat stones placed together at the top and apart at the bottom, like the two sides of a triangle), or with drain tiles; or, where a very large flow of water has to be provided for, with inverted tiles, and covering tiles placed above the bottom one, or with larger tiles made on purpose.

8325. *Submain drains.* There should be a cross submain at the bottom of every field or stretch of drains, to receive the water from all the parallel drains; and such submain drain should always be cut six inches deeper than the drains running into it, that the water may have a free drop, which will prevent the lodgment of mud or sand at their junctions or mouths. Open cuts or ditches, either as mains or submains, should never, except from necessity, be adopted, being apt to get filled with mud and grass, by which the water is thrown back into the drains, and often chokes them; besides, the loss of land, annoyance in ploughing, constant expense of cleaning, and unsightly appearance of such drains, are serious objections.

8326. *Parallel or frequent drains.* Having thus provided a main drain, with submains flowing into it, matters are prepared for setting off and for executing parallel or frequent drains in the field. These drains can be executed at any season when the weather will permit; but spring and summer are most suitable for the work. It is best to execute the drains when the field is in grass, as they can then be cut in all kinds of weather, and in a more cleanly manner.

8327. *In setting out the drains,* the first object for consideration is, the nature of the subsoil: if it consists of a stiff strong clay, or a dead sandy clay, then the distance from drain to drain should not exceed from ten to fifteen feet; but if there is a lighter and more porous subsoil, a distance of from eighteen to twenty-four feet will be close enough. When the ridges of the field have been formerly much raised, it suits very well to run a drain up every furrow, which saves some depth of cutting. At whatever distances the drains are placed, they should be run parallel to the ridges, which is commonly in the steepest descent. They should always be run quite parallel to each other, and at regular distances, and should be carried throughout the whole field *without reference to the wet or dry appearance of portions of the field*; as uniform and complete dryness is the object, and land, which may be considered dry in its natural state, will show wet when compared with properly drained land. A three-foot drain should be carried along the ends of these drains at the top of the field, and at a distance of about nine feet from the fence, especially if it is a hedge fence. Such a drain is necessary for the growth of the hedge; but if made nearer than nine feet, the roots are apt to get into the drain, and choke it up by degrees. It is of importance to be accurate in setting out the drains as described, as it secures uniformity of dryness, and in all future operations, or at any time, it is easy to ascertain the line of any drain.

8328. *Excavation.* The lines of drains having been marked off in the field, the drainer begins by cutting with a spade on a line; then removing the first layer to the depth of a spitful of about thirteen or fourteen inches wide all along, another follows with a narrower and tapering spade, made for the purpose, taking out another layer; and, when picking becomes necessary, a third man follows with a pick; and a fourth with a large scoop shovel to cast out the earth, and a smaller scoop shovel is used to clean out the bottom, which should be cut as narrow as will allow the last drainer a footing, generally about three or four inches. From two to two feet and a half from the surface are the best depths for such drains; the latter always to be preferred. The bottom should be cut as straight and uniform as possible, so that the water may flow freely along at all places, and it is better to cut a little deeper when there is any sudden rise of the surface than to follow it; and where sudden hollows occur, the cutting may, on the same principle, be less deep: attention to this also admits of after straightening or levelling of the surface, without injury to the drains. The workmen, in cutting, should throw the earth to the right and left from each alternate drain, as that allows the plough to go regularly and fully occupied *boutings* (a Scotch term for a rotation or traverse of the plough) in filling in the earth, whilst each alternate ridge or space is left for getting in the stones free from the earth thrown out.

8329. *Filling.* The stones may either be laid down at intervals, by the sides of the drains, to be there broken; or, being broken in masses at some convenient spot, can be brought by the carts, ready to be filled in. No part of any drain should, if possible, be filled in, till the whole line is cut out and inspected, but the sooner drains are filled, after having been cut, the better. Sometimes, when there is much tendency of the sides to fall in, it becomes necessary to fill in going along. Cutting at the end of summer, when there is little water in the soil, or in a dry season, saves much of this. In soft or sandy bottoms, by cutting the drains to half the depth in the first instance, and allowing them to remain in this state until the water has drained from the upper stratum of the soil, the lower part may be cut out with more safety from falling in. The stones covering the drains should not be filled in nearer to the surface than eighteen inches, leaving sixteen inches free for deep ploughing.

8330. *Covering the stones.* The upper surface of the stones having been made straight and uniform, the whole should be neatly and closely covered with thin turfs, cut from the adjoining surface, or brought from some suitable place. Strict attention to the correct execution of this operation is of the greatest importance, as many drains are ruined at once, from the running in of the loose earth. Thick turfs are objectionable, from the difficulty of getting them to fit close. Straw, rushes, broom, whin, and other like material, are very objectionable, affording no certain or uniform security, and forming a receptacle for vermin. Peat may be used to advantage. Where the deepest ploughing has been executed, there should always remain a firm crust of earth undisturbed over the stones of the drain; and no surface water should ever have access to the free way of a drain by any direct opening, but should find its way, by percolation or filtration, through the subsoil, and should always enter by the sides of the drains. For this

purpose, it may be of advantage to tread or beat down closely the first two inches of soil put over the turf, in order to form the permanent crust.

8331. *The cost of executing such drains varies, of course, according to circumstances: the cutting cost (in 1832) from 1s. 6d. to 2s. 6d. per rood of thirty-six yards, according to the hardness of the subsoil; the stones, if collected on the adjoining fields, will cost from 1s. to 1s. 6d. per rood, the breaking from 9d. to 1s. per rood; about one and a half cubic yard of broken stones will fill a rood of a well-cut drain; the putting in of the stones may be calculated to cost about 3d. per rood, and the turving about 1d.; the filling in of the earth over the stones with the plough will cost about 1d. per rood. The whole cost, per rood, of common drains, may be taken at 4s. 8d., or, including a charge to cover proportion of main drains, 5s.*

8332. *The following table exhibits the cost per Scotch acre of draining in this method, at various distances between the drains; and as this method of draining forms a permanent improvement of the land, it is presumed the proprietor should defray part of the expense. The table is constructed to show how much it will cost the landlord in money to do the cutting, carrying, and (when necessary) breaking of stones, filling in, and turving; and how much the horse-work, &c., which can be performed by the tenant, will cost, charged at the ordinary rates:—*

Subsoils to which the Distances are applicable.	Distance between the Drains in Feet.	Roods per Acre.	Cost per Rood to Landlord.		Cost per Rood to Farmer.		Total Cost per Acre.	
			s. d.	£ s. d.	s. d.	£ s. d.		
For stiff clay subsoil -	10	48	3 4	8 0 0	1 8	4 0 0	12 0 0	
	11	43 ³ / ₄	—	7 5 10	—	3 12 11	10 19 9	
	12	40	—	6 13 4	—	3 6 8	10 0 0	
	13	37	—	6 3 4	—	3 1 8	9 5 0	
	14	34 ¹ / ₂	—	5 14 5	—	2 17 3	8 11 0	
Sandy clay -	15	32	—	5 6 8	—	2 13 4	8 0 0	
	16	30	—	5 0 0	—	2 10 0	7 0 0	
	17	28 ¹ / ₄	—	4 14 2	—	2 7 1	6 3 3	
	18	26 ³ / ₄	—	4 9 2	—	2 4 7	6 13 9	
	19	25 ³ / ₄	—	4 4 5	—	2 2 3	6 6 8	
	20	24	—	4 0 0	—	2 0 0	6 0 0	
	Free strong bottom -	21	23	—	3 16 8	—	1 18 4	5 15 0
		22	21 ⁵ / ₄	—	3 12 6	—	1 16 3	5 8 9
		23	20 ³ / ₄	—	3 9 2	—	1 14 7	5 3 9
24		20	—	3 6 8	—	1 13 4	5 0 0	
25		19 ¹ / ₄	—	3 4 2	—	1 12 1	4 16 3	
26		18 ³ / ₄	—	3 1 8	—	1 10 10	4 12 6	
27		17 ³ / ₄	—	2 19 2	—	1 9 7	4 8 9	
28		17	—	2 16 8	—	1 8 4	4 5 0	
29		16 ¹ / ₂	—	2 15 0	—	1 7 6	4 2 6	
More open bottom -	30	16	—	2 13 4	—	1 6 8	4 0 0	
	31	15 ¹ / ₂	—	2 11 8	—	1 5 10	3 17 6	
	32	15	—	2 10 0	—	1 5 0	3 15 0	
	33	14 ¹ / ₂	—	2 8 4	—	1 4 2	3 12 6	
	34	14	—	2 6 8	—	1 3 4	3 10 0	
Irregular beds of gravel or sand, and irregularly open rocky stratifications -	35	13 ³ / ₄	—	2 5 10	—	1 2 11	3 6 9	
	36	13 ¹ / ₃	—	2 4 5	—	1 2 3	3 6 8	
	37	13	—	2 3 4	—	1 1 8	3 5 0	
	38	12 ³ / ₄	—	2 2 6	—	1 1 3	3 3 9	
	39	12 ¹ / ₂	—	2 1 1	—	1 0 7	3 1 8	
	40	12	—	2 0 0	—	1 0 0	3 0 0	

8333. *Remarks.* In cases where time or capital are wanting to complete the drainage, each alternate drain may be executed in the first instance; and the remainder can be done the next time the field is to be broken up. After the drainage has been completed, a crop of oats may be taken from the field; and immediately after that crop is off the ground, the field should be gone thoroughly over with the subsoil plough, crossing the line of drains at right angles.

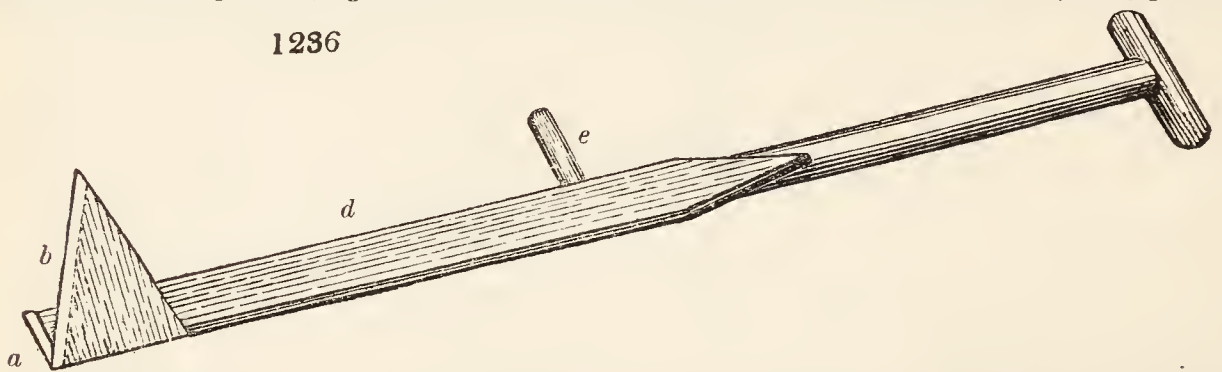
8334. *The subsoil plough* has been constructed on principles appearing the best fitted to break up the subsoil completely to a depth sufficient for most thorough cultivation, say fourteen to sixteen inches, allowing the active soil still to remain on the surface; to be of the easiest possible draught, in reference to the depth of furrow and firmness of the subsoil; and to have strength and massive weight sufficient to penetrate the hardest stratum, to resist the shocks from fast stones, and to throw out all stones under 200 lbs. in weight. All this has been accomplished, and practically proved, over an extent of at least 200 acres of various soils. This plough requires four good horses, an active ploughman, and a lad to drive the horses and manage them at the turnings. Six horses, yoked three and three abreast, may be necessary in some very stiff or stony soils. A common plough drawn by a pair, goes before the subsoil plough, throwing out a large open furrow of the active soil. The subsoil plough following, stirs up thoroughly and breaks the bottom, when the next furrow of the active soil is thrown over it; the stones brought to the surface by the subsoil plough being thrown aside, on the ploughed part of the land, by a boy or lad; and so on, till the whole field is gone over. The boy should carry a bag of wooden pins, that he may mark the site of the large fast stones which the plough cannot throw out, and which must afterwards be dug out with the pick, and, perhaps, blasted. This large plough is a sort of horse-pick, breaking up without raising to the surface the subsoil. Channels are thus regularly formed for the water to flow from all parts towards the drains. The atmospheric air being also by this means freely admitted to the subsoil, the most sterile and obdurate clay becomes gradually ameliorated, and the common plough may ever after be brought to a depth of from fourteen to sixteen inches without obstruction; and with the power of three horses yoked abreast, and managed with ease by the ploughman, without any person to drive. By being thus yoked together, and near the point of resistance, the horses have great power; and, the furrow turned over being broad in proportion, nearly as much ground will be gone over in a day, as with a plough and a half drawn by a pair of horses. The cost of subsoil ploughing an acre may be estimated at 30s., being one sixth of what a similar depth would cost with the spade; and, upon the whole, as effectually done. A subsoil plough with apparatus cost, in 1832, from 7l. to 8l.

8335. *The effect of this mode of draining and deep working on close-bottomed land* is quite wonderful. After one turn of green cropping, with the usual application of lime and dung, the formerly scanty sterile surface soil becomes a deep rich loam, carrying, without fail, crops of wheat and barley, producing from nine to twelve bolls per acre of wheat, and from eight to twelve of barley; the hay and pasture following being also very fine. When fields have been thus dried and worked, it is recommended to plough them at all times without ridges, or water furrows, preserving one uniform sheet of soil over the whole field.

By this means every superficial inch is allowed to be productive. There is no carrying away of the surface by accumulated currents of water; and the water falling as rain, is left to percolate through the soil where it falls, thereby uniformly enriching the whole extent. There is a powerful process of nature much facilitated by complete draining and deep working, viz., the constant circulation of air to and from the bottom of the soil, produced by the constantly varying relative temperatures of the atmosphere and the earth. When heavy rain falls, the air is completely expelled from the interstices of the soil, the water taking its place. Also, when the rain has ceased to fall, the water gradually subsides to the level of the drains, or, at all events, to the level of the bottom of the subsoil that has been moved by the plough, and fresh air takes its place throughout the soil; thereby promoting doubly a chemical action vastly conducive to the decomposition of the soil and the manure it contains; and, of course, to the nourishment of plants. When land is uniformly and completely dry and deep in the soil, it is more easily wrought; it can be wrought at any time when it does not rain; it comes to a state proper for sowing earlier, and more uniformly; a circumstance of great importance in our climate: it affords a wide and uninterrupted range for the roots of plants; it resists the evil effects of long droughts, as well as of long periods of wet; it never honeycombs, as it is called; it seldom throws out plants of any kind in frosts: it never suffers from the treading of cattle in removing the green crop; for, although apparently puddled or poached on the surface, yet, being dry below, a single ploughing restores the soil to a proper tilth; and it gives an earlier harvest, and affords a dry bed for cattle when in pasture. In the conclusion of his article, Mr. Smith observes, that the subject of thorough under-draining, and of deep ploughing, is one of so much importance, and so extensive in its parts, that volumes might be written on it to the advantage of the country. (*Report of Drummond's Agricultural Exhibition, &c.*)

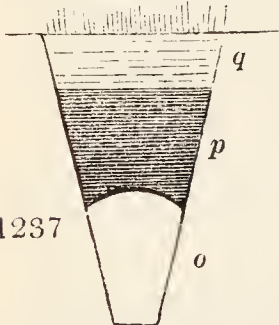
8336. — 4295. *Plug or clay draining* is performed chiefly in pasture land, by first digging out a drain from eighteen inches to two feet deep, two inches wide at the bottom, and about one foot wide at the top. In the bottom of this drain is placed what is called the suter, or plug, which may be two or three feet in length, one inch and three quarters wide at the bottom, and four inches wide at the top. To one end of this plug is attached a chain, about two feet in length, which is connected with a lever for drawing the plug forward. The drain being dug out, and the plug being put in its bottom, the excavated clay is then firmly rammed over it; when this is done, the plug is moved forward by means of the lever, and the same operation of ramming is repeated, till the whole length of drain is filled in. The drain is completed by replacing the surface turf as it was before the drain was dug out. This mode of draining is described in the *Quart. Journ. of Agr.*, vol. iv. p. 501., by W. J. Evans, Esq., who says "that he has executed in this manner, during three years, more than 400 miles of clay drains, to his entire satisfaction." "Pasture land," he says, "which had been before deluged by surface water, has undergone an entire change of character." The implement, *fig. 1236*, is used in clearing out the bottom of these drains; and *fig. 1237* is

1236



a section of a drain made and filled up. *Fig. 1236* is the bit or grafting-iron; *a* is the width of the bottom, one inch and three quarters; *b*, the side bit, length of cut six inches; *c* is the width of the back of the side bit, worked out of the main bit, which must be of the best tempered steel, four inches and a half; *d* is the length of the main bit from the step to the bottom, one foot six inches; *e* is the treading step; and *f*, the handle, which is about the length of a common spade handle. *Fig. 1237* is a section of a main drain, two feet deep, filled up again; *o* is the waterway left open, eight inches and a half high; *p* is the rammed clay above the suter, or plug, nine inches deep; and *q* is the returned turf, with the grassy side uppermost, six inches and a half thick. (*Quart. Jour. Agr.*, vol. iv. p. 503.)

1237



8337. — 4320. *Embankments*. An essay will be found in the *Highland Soc. Trans.* (vol. viii. p. 97.), in which are enumerated all the books, or articles, which have appeared on the subject in the English language up to 1828, the period at which the essay was written. In the same work (vol. viii. p. 91.) will be found a section and description of an embankment formed by rows of piles, filled in between by furze, and employed to direct the course of a river.

8338. — 4380. *Irrigation*. An excellent practical work on this subject, and on draining, *Stephens's Practical Irrigator and Drainer*, has reached a second edition since the publication of this Encyclopædia. Any thing new in such a work was not to be expected; but, being entirely of a practical nature, and by a practical man, it may safely be recommended as one of the best books on the subject.

8339. — 4406. *Sluices, trunks, and valves for embankments* are now made of cast iron, on an improved principle; and, when properly fixed in by a mass of masonry and cement, they are found to retain the water of a pond, and admit it at pleasure, with as much accuracy and ease as a brass cock does the contents of a beer barrel.

8340. — 4485. *Artesian wells*, or those produced by boring, are so named from their having been first used in the neighbourhood of Artes in France. Upon a review of the appearances observed in these wells, it is quite evident that they must always succeed where an inclined stratum of a fissured or porous limestone, or other porous stone, is included between two waterproof beds of clay; one of which sets a limit to the sinking of the water downwards, and the other prevents it from rising above the surface. The existence of such a cover is evinced by all boring works. A waterproof stratum of clay must always be penetrated, before reaching the spring water: and it may easily be conceived that the undermost layer is never wanting. Although, for the most part, some thinner strata of limestone supply its place, yet the strata, which conduct the water, always contain it in crevices, which are much more numerous on the surface than in the centre of the beds. Thus there is a demonstration, as in a boring work at Blengel, that, even in the limestone itself, beds of clay occur. From these circumstances it is easily explained how we can never hope to sink Artesian wells in granite, gneiss, porphyry, serpentine, &c. Even in schistose mountains, it would not be advisable to sink these wells, because, if water were found there, it would be very easily impregnated with sulphuretted hydrogen, from the abundance of pyrites occurring in these strata, and thus be unfitted for many uses. Limestone, on the contrary, which is very insoluble, experience teaches us, yields a very pure water. These observations especially relate to the Pas de Calais.

8341. *Other districts*, where water has been bored for, show a similar geognostic constitution to the Pas de Calais. M. Garnier, in his *Manuel du Fontanier-sondeur, &c.*, notices this, with regard to Boston in America, and Sheerness in England. London (where many sugar-works, distilleries, and breweries

have, for a long time, been principally supplied with water from Artesian wells) lies in the middle of a basin-shaped hollow, the fundamental rock of which is a limestone belonging to the chalk formation; which also forms the heights in the vicinity, and which is covered with clay, though at times not immediately. The wells, which are not sunk to this London clay, give abundance of clear, but mostly very hard, water; while those which penetrate through the London clay, into the subjacent plastic clay, a formation immediately covering the chalk, and consisting of alternating beds of sand, clay, and boulders, yield a very soft and pure water, which, on piercing this clay, often ascends with such violence that the workmen have scarcely time to escape. Here the plastic clay seems to be either the conducting medium, or the reservoir of the water yielded by the chalk. Paris is known to be situated in a district whose geognostic relations are almost identical with those of London, and therefore we cannot wonder that there, as well as in many other parts of the north and east of France, Artesian wells may everywhere be sunk; nor can we doubt of the extension of this very useful discovery. (*Jameson's Phil. Journ. for July, 1830.*)

8342. *We must not, however, expect to be able to sink Artesian wells in every description of country, as has been thoughtlessly asserted.* On the one hand, the nature of the ground sometimes absolutely prevents it, as in granite districts; and, on the other hand, it is possible that a perforation, if made too near a bored well affording water, may not yield any; should the latter, for example, be fed by a subterranean current, in place of being supplied by a sheet of water; or should the perforation be made upon the extremity of a basin with inclined strata, resting upon a formation of a very different nature. M. Garnier's *Manuel du Fontanier-sondeur* contains all that can be desired on the subject of boring these wells. (*Ibid.*)

8343. *General observations on Artesian wells.* Great subterranean sheets of water exist at various depths. These sheets are more commonly met with in the plane of superposition of strata of different formations. They, however, frequently occur at various heights in the great masses of earth; such as those of clay, chalk, and even marine limestone containing cerithia, when these masses are entire, and of great thickness. According to the slope, the undulations, or the declivities which are presented by the plane of superposition of the permeable deposits in which the waters flow between impermeable strata, these great sheets of water are met with at all depths; but it is impossible to lay down any constant rule with respect to them. (*Ibid.*)

8344. *In order that these waters may be capable of ascending,* it is necessary that the formations among which they occur be entire, in the state in which they were originally deposited; and that they be not intersected by large valleys, or deep ravines, through which the waters would find a free and easy exit.

8345. *It would be in vain to search for springs in deposits which, at no great distance from the place of boring, are intersected by deep valleys,* or when the formations are internally crooked, filled with tortuous separations, and greatly disturbed, whether by the contraction attending the desiccation of the mass, or by internal shocks, swellings, or earthquakes; or, lastly, when these Neptunian formations, such as plastic clay, chalk, oolite, and shell-limestone, are raised up, and present precipices at the surface. In such localities, we need not expect success in boring for springs, unless by penetrating deeply into the mass of the chalk, in search of the sheets of water in its lower part; or even by traversing it entirely, in order to come upon those in the clays, oolites, and shell-limestones; or, lastly, unless by penetrating deeply into the latter, when they happen to be raised to the surface, and to present cliffs, or are intersected by valleys of greater or less depth.

8346. *In a country composed of elevated plains,* if, in place of boring to the necessary depths for reaching the different water-sheets which are commonly the most abundant, and, at the same time, those which rise highest, the boring is stopped at higher levels, less distant from the surface, it is more than probable that the ascending waters will stop more or less beneath the surface of the ground, according to the depth of the borings. When this occurs, we ought to be far from considering the operation as having failed; because in this case the water does not rise above the surface, and in most instances, according to the localities and the nature of the ground, steps may be taken to remedy the deficiency. Thus, for example, when the water of a boring only rises to within a certain number of yards from the surface, but in sufficient quantity, it might be conducted from the point to which it reaches, by a small gallery, into some neighbouring well, or into one dug on purpose; and there might thus be produced a kind of artificial fall, which might be employed to make the water ascend to the surface of the ground, and even beyond it, by employing for this purpose either the hydraulic ram (*bélier hydraulique*), which would always give a third of the volume of water, or a wheel, which might be placed at the point of the fall, and which, working a pump suitably placed, might raise the third, or perhaps even the half, of the volume of water; or, in short, any other hydraulic machine of the kind. But these means would be practicable, only in so far as the wells into which the waters should be precipitated, might not allow them to run off into strata of permeable deposits.

8347. *Circumstances which it is necessary to examine and appreciate before resolving upon boring a well.* It is necessary to examine the physical constitution or the nature of the ground, and the disposition of the surface of the country, with reference to the mountains which overlook it, the valleys by which it is intersected, and the springs which rise in those valleys. The latter it is particularly necessary to examine, before deciding upon boring a well, as many of them are natural wells. It is of importance to select a fit person for boring; the art not being merely mechanical, and such as can be practised by any borer. Besides attending to these circumstances, it is necessary to be possessed of perseverance and courage, which will lead us to disregard the delays and difficulties often unavoidably connected with the operations of boring. (*Héricart de Thury, as quoted in Jameson's Journal for July, 1830.*)

8348. *Boring for water in deep sand.* Mr. David Greenley of London has been lately (August, 1834) very successful in obtaining "an abundant supply of pure water," at Diss in Norfolk, at a depth of upwards of 600 feet below the surface. A well had been previously sunk in the same place; but, in consequence of an immense quantity of sand rising whenever the pump was worked, it was almost useless. (See *Arch. Mag.*, vol. i. p. 210.)

8349. — 4524. *Rending rocks or stones.* A newly invented apparatus for this purpose has been brought into notice by Mr. D. Millar, road contractor and builder in Edinburgh. The apparatus appears to be a more efficient boring instrument than any hitherto in use. It is calculated to bore or tap to the depth of 100 feet or upwards, and may be put in operation either by manual labour or steam. (*Scotsman*, Feb. 22. 1834.) An instrument for the same purpose was invented by Mr. Mallet of Dublin in 1832. Mr. Mallet's object was to split all rocks that could be separated into laminæ, by the application of male and female screws; instead of blasting, as heretofore practised, with gunpowder. The process is as follows: — Jumper holes are formed in the direction of the proposed fracture, as at present; but, instead of filling them with gunpowder, a split female screw is inserted in each hole, and the fracture is effected by the insertion of a conical or male screw. (*Arch. Mag.*, vol. i. p. 93.)

8350. — 4541. *Draining and bringing into cultivation moss-lands or peat-bogs.* The Liverpool Agricultural Society having awarded its premium to Mr. Reed, late of Chat Moss, but now a professional drainer, we give the following as the essence of his paper. We may premise that we had the pleasure of inspecting Mr. Reed's farm at Chat Moss, near Liverpool, in August, 1831, and were much gratified and instructed by what, when there, we saw and were told by Mr. Reed.

8351. *Draining.* The water, to a considerable depth from the surface, being held in a great degree by capillary attraction, drains should be frequent, and more or less distant according to their depth. Open drains to divide the fields may be placed at any distance not exceeding 100 yards. The covered drains should run at right angles to the divisional drains. Sixty-six yards, or three chains, Mr. Reed has

found the best width between the open drains; and, consequently, as the covered drains are at right angles to these, their length will be sixty-six yards. The open drains may be four feet wide at the top, from three feet six inches to four feet deep, and fourteen inches wide at the bottom. The covered drains should not be more than five or six yards apart, and three feet deep. No material is wanted to cover them but the moss itself. "The form should combine the principle both of the shoulder and the wedge drain, and the somewhat square clod, which is first taken out, when dried to a certain extent by the weather, becomes the cover."

8352. *Preparing the surface.* "Moss, or peat bog, is not a soil, but an accumulation of dead, dying, and living plants growing in water." To form a soil, therefore, it is necessary to destroy, to a certain depth, the original structure of the moss, both for the purpose of destroying vegetation, and facilitating the passage of the water to the covered drains. Digging is perhaps the best mode of destroying the structure of the moss, and afterwards, a cutting machine formed by fixing circular knives on the cylinder of a common roller, may be applied. In due time, the surface may be harrowed, and afterwards manured, and sown with a crop. Any description of earth is useful, as tending to consolidate the moss, and to facilitate its decomposition; but, to obtain a good crop the first year, putrescent manure in a considerable quantity is absolutely necessary.

8353. *After cultivation.* "Manure of some sort being applied, almost any description of crops may be had; but potatoes are perhaps the best article to begin with; 2d, wheat; 3d, clover, without grass seeds; 4th, oats. The rotation may be varied, so as to include almost every crop."

8354. *The preparation of coke or charcoal from peat or moss* has been effected in different parts of Scotland, and in Ireland, and the charcoal thus produced has been found superior to many kinds of coal for smelting iron, and the use of smiths' forges. This arises from the total absence of all sulphuric matter in the peat, which renders it almost equal to the charcoal of wood, to which it is well known the Swedish iron owes its principal excellence. The charring of peat for use in smelting iron has been strongly recommended as a means of giving employment to the labouring population. (See *Brit. Farm. Mag.*, vol. v. p. 360.)

8355. — 4557. *In improving moist lands where manure cannot be obtained*, covered drains are unnecessary; but open drains are made at distances of from ten to twelve yards. The stuff taken out of the drains is spread on the intervening spaces, on which also clayey earth is laid, in quantity varying from thirty to fifty yards per statute acre. The land is afterwards pared with a breast plough by men; or with a plough constructed for the purpose, drawn by a horse; then partially burned, the ashes distributed pretty equally over the surface, the seed sown, and ploughed in with a slight narrow furrow. Tolerable crops of oats may be obtained in this manner; and, sometimes, inferior crops of clover are made to follow the oats: in others, oats follow oats, year after year; the paring and burning being a necessary preliminary to each crop. This is certainly better than nothing, and is, perhaps, the best practice where manure cannot be made or procured at a moderate price. (*Brit. Farm. Mag.*, vol. viii. p. 42.)

8356. — 4688. *The question of corn rents* has been discussed at considerable length, but nothing has been said as to the *modus operandi* of converting money into a grain rent. In a cultivated district, where the farm proceeds arise chiefly or wholly from the sale of grain, an experienced farmer, in offering for a farm, forms an estimate of the quantity of grain he may expect to raise for the market, and what proportions thereof he can afford to pay as rent, after allowing for interest on capital, profits, and expenses. In this estimate, price forms a most important ingredient; and it is the fluctuation in the price of grain which has occasioned the adoption of grain rents. From the commencement of the present century till the conclusion of the war, the generally high prices of grain produced keen competition in farm-taking, and a rapid rise of rent was the consequence; but those who, chiming in with the spirit of the times, entered into leases at high rents, between 1810 and 1815, found, by 1821, that, in reckoning on a continuance of high prices, they had calculated without their host. About that period the cry for deductions of rent became loud and general; and that cry was in many instances responded to by the landlords giving temporary relief. This relief was, however, only temporary; and, in many cases, did harm, as it tended to keep up competition in farm-taking; and though a proprietor who had acquired a character of liberality felt little alteration in his rent roll on granting new leases, yet, as that liberality formed a very prominent ingredient in the farmer's estimate, it was naturally expected to be put in requisition where other sources failed. This unsettling of all covenants between landlord and tenant soon became disagreeable to all parties. The farmer had to become a humble suppliant, and the landlord to put up with a diminished income, without being altogether certain how far the claims on his generosity were well founded, or to what extent they might proceed. It therefore became a matter of necessity to make such arrangements as would restore the farmer to his original and proper state of independence, and the landlord to a state of certainty as to the extent of his income. Those farmers who had entered on nineteen years' leases during the last years of the war, or soon after its termination, had calculated on receiving, on an average of years, 35s. per boll for wheat, 25s. per boll for barley, and 20s. per boll for oats; but as prices soon fell, and continued below these rates, profits on farming became extinct, and capital began to decrease. Under these circumstances, farmers petitioned for permanent reductions of rent, suitable to the low prices; or craved leave to retire. Renunciations were written out by land agents, in which terms were proffered to the tenant less favourable than if his lease had expired, connected with an offer to convert the money rent into grain rent, payable in money by the county fiars price (the average price for the year) of grain for the current crop. Thus a tenant who had entered on his farm in 1815, and who grumbled at low prices in 1821, paying a money rent of 400*l.*, agreed to pay, under the new arrangement, during the currency of his lease, money to the amount of the highest fiars per 100 bolls of wheat, 100 bolls barley, and 100 bolls oats, these three bolls at 35s., 25s., and 20s., amounting to 4*l.*; the maximum reaching to 85s. or 90s., and the minimum to 60s.; thus giving a preference to the tenant in the fluctuation. When farmers entered into leases subsequently to 1821, on money rents, 75s. for the three bolls became the standard of conversion, because, warned by a succession of low prices, farmers had offered lower money rents; but in either case, wherever the plan has been adopted, it has been found to work well. Where money rents still exist, they are ill paid; the partial payments are entered to account, and the arrears press as an incubus on enterprise or improvement. The situation of the landlord is not enviable, and that of the tenant is deplorable; but, with the example before them, this state of things will soon rectify itself. In pastoral districts, something, too, might be devised to produce a fluctuating rent, regulated by the average price of sheep, wool, and cattle; and thus to place the grazier and his landlord on that same safe sort of footing now enjoyed by the more reflecting portion of the landlords and farmers in the cultivated districts. (A. G.)

8357. — 4820. *On the capital required in farming*, an excellent paper will be found in the *Quart. Jour. of Agr.*, vol. iii. p. 450. To this paper is annexed a list of the implements of husbandry, live stock, seeds, lime, and expence of labour required for stocking a farm in Scotland, in 1831, of 500 acres. The total amount required was 3569*l.* 17s. 11*d.* The list is given in great detail, and well deserves the study of young men intending to become occupiers of farms.

8358. — 4925. *Rotation of crops.* Independently of the benefit which a rotation of crops affords to the cultivator, by the greater variety of articles which it enables him to cultivate, there is less danger of his suffering in years of scarcity; because it seldom or never happens that the seasons are unfavourable for every description of crop. Thus, a very dry season is favourable for the production of corn, while a very wet one is unfavourable for corn, but produces abundance of herbage, roots, and grasses, which directly, or by means of nourishing or fattening animals, furnish a supply of human food.

8359. — 4936. *For clays and loams of an inferior description*, the following rotation is recommended in the body of the work: —

- | | | |
|-----------------------|--------------------------|-----------------------------------|
| 1. Fallow, with dung. | 3. Clover and rye grass. | 5. Beans, drilled and horse-hoed. |
| 2. Wheat. | 4. Oats. | 6. Wheat. |

Here barley forms no part of the rotation, though inferior loams are often well calculated to yield fair crops of that grain: such loams are to be met with in many parts of Scotland at altitudes where wheat could not succeed. Another objection to this rotation is, that wheat forms the last and also the first crop of the course, with an intervening fallow: for inferior loams, such cropping is too severe; and in any case two crops of the same species in succession should, if possible, be avoided, even although a fallow or green crop intervene. The following rotation, which is practised on poor clays in the Carse of Gowrie, appears preferable, either on inferior clays, or loams, where wheat can form part of the rotation:—

- | | | |
|-----------------------|-----------------------|--------------------------|
| 1. Fallow, with dung. | 3. Drilled beans. | 5. Clover and rye grass. |
| 2. Wheat. | 4. Barley, with dung. | 6. Oats. |

On inferior soils, five successive crops, with only one manuring, cannot be expected to reach mediocrity. The general practice is to give rather less to the fallow crop, say fifteen tons per acre, and ten tons per acre, ploughed down in the end of autumn, on the bean stubble, for the barley. The growth of this plant is so rapid, that, on strong lands, where the dung has not been incorporating with the soil throughout the previous winter months, it is found to be of little benefit to the barley crop, and is therefore seldom applied at seedtime. In this rotation, too, five years intervene between each species of crop; the only drawback is, that barley after beans or peas is darker coloured than after a fallow or a green crop; but purchasers will make allowance for this, when they perceive that such colour does not proceed from damp in the stack. (*A. G.*)

8360.—4937. *The rotation for thin clays* in the body of the work is objectionable, from the land being continued too long in grass.

- | | | |
|------------|-----------|----------|
| 1. Fallow. | 3. Grass. | 5. Grass |
| 2. Wheat. | 4. Grass. | 6. Oats. |

On the thin clays in the Carse of Gowrie, of which there is a considerable breadth, the rotation generally followed is the same as that recommended above. Pasturing poor retentive clays will not pay. Such land is sufficiently tenacious without the tread of cattle, and the forage would be extremely scanty. Where the clay soil is so miserably poor as not to carry beans, a four-course shift might be adopted, keeping the grass only one year. On all clay lands it is often difficult to obtain sufficient mould for grass seeds in spring, among autumn-sown wheat; and, except in early situations, spring-sown wheat will not succeed on cold clays; hence a cross crop, that is, oats after wheat, is sometimes resorted to, for insuring a fair braird (sprouting, or plant) of clover and grass seeds. With this exception, the practice is not advisable. (*Idem.*)

8361.—4939. *In the "rotation for light soils,"* we have—

- | | |
|----------------------------|--------------------------|
| 1. Turnips. | 3. Clover and rye grass. |
| 2. Spring wheat or barley. | 4. Oats or wheat. |

What I consider defective in this rotation is the possibility (although not clearly expressed) of following barley with wheat, after only one intervening green crop. It has been found, by dear-bought experience, that wheat succeeding to barley, with only an intervening fallow grass, or other green crop, is diminished in produce, from one third to one half in quantity on light lands; on strong retentive soils, the diminution is less perceptible; but on all soils, the practice should be avoided. (*Idem.*)

8362. *The land under regular rotation of cropping all over the country* has been rendered, by frequent repetition of the same sort of grass seeds, what is termed "clover-sick;" a state of the soil, according to De Candolle and others, produced by excrementitious deposit, hurtful to clover, but favourable to the growth of the cereal crops. On many farms a seven-course shift has of late been adopted, it being found that clover succeeds better after a cross crop, otherwise an objectionable mode of farming: the land requiring, as it would appear, two successive white crops to purify it from clover deposits, and to prepare it for producing that plant in a healthy state. Aware of this, the writer of this article, twelve years since, commenced the following rotation on light dry land, which, by frequent cropping, had become so "clover-sick," as to produce little else than rye grass.

8363. *Rotation of eight years:—*

- | | | |
|--------------------------------|--|---------------------------------|
| 1. Potatoes and turnips. | 3. Grass after barley, peas after wheat. | 5. Turnips and potatoes. |
| 2. Half wheat and half barley. | 4. Oats, on both divisions. | 6. Barley and wheat, as before. |
| | 7. Grass after barley, and peas after wheat. | 8. Oats. |

Here the rotation is after the four-course method; only the potatoes alternate, as do the barley and wheat, and the peas and grass; so that each of these species of crops occurs only once in eight years on the same ground, with the exception of oats, for which each soil is well calculated, and which occurs once in four years. From this mode of cropping, a much heavier crop of clover is obtained from the half of the division than was formerly from the whole. The pea straw also adds to the horse fodder; and by it the dung is considerably augmented. The practice begins to recommend itself in the neighbourhood. The farm on which this course of cropping originated lies on the northern bank of the Carse of Gowrie, and at an elevation of from 400 to 500 feet above the level of the sea, consequently at the full limit where wheat can succeed. (*Idem.*)

8364.—4944. *Fallows.* It is the opinion of some, that the mere exposure of soil to the drying influence of the sun during the summer season will contribute towards its fertility; but, assuming that the land is what farmers call sweet, that is, friable, and free from weeds, it will profit more by being covered with vegetation, or otherwise shaded from the sun and drying air, than by being exposed to it. This is shown by an able article in the *British Farmer's Magazine*, vol. iv. p. 10.

8365.—4955. *Kirkwood's grubber* has, subsequently to its first being made known, been greatly improved by the inventor, an ingenious mechanic, at Tranent, in East Lothian. (See *Quart. Jour. of Agr.*, vol. ii. p. 848.)

8366.—4965. *The use of fresh or unfermented dung* for turnips has, of late, been much recommended by several agriculturists, and has been advocated by Sir H. Davy, on chemical principles. But it appears that practice does not always support it. When Davy's lecture appeared, it was sent, by the then President of the Board of Agriculture, to a friend in Tweedside, who farms to an extent of several hundreds of acres of turnips yearly. This being in the turnip season, he directed an experiment to be made in two parts of a field with fresh dung from the fold-yards against the dunghill. The fresh dung failed by thirty per cent., and similar trials made on another farm led to the same result. It may be observed, however, that, in making experiments of this kind, something may be misunderstood. If the fold-yards were kept in a rough state, the fresh dung might be little better than wet straw, and containing little or no excrementitious matter; and if it were taken from near pigsties, or a chaff house, it might be nearly as much decayed as if it had lain in the dunghill. It is a long-established opinion, that dung fit for raising turnips must be thoroughly rotten and decomposed, so as to cut like a jelly; and though in this case a loss takes place, both of bulk and matter, the quality of the manure is undoubted. Perhaps dung in a state betwixt unfermented and total decomposition is preferable to either; and this opinion the following statement appears to confirm. During two succeeding years, the dung required for turnips on a farm was laid in a moist state on a dunghill about ten weeks before turnip sowing. A short time before sowing, it was turned, carefully shaken out, and laid lightly together. When laid on the land, it appeared to be in a most excellent state; the decomposition was going on, but had not ceased. A steam arose from the heaps of dung, and, the arrangement of the carts and ploughs being very close, ten minutes did not elapse

until the turnip-seed was sown, and pressed close to the dung by a roller. The braird (sprouting) of Swedes was everywhere most excellent; and, through the summer, grew with a rapidity seldom seen, and produced a crop rarely to be met with in the best turnip districts. The field was a sandy loam, of weak quality, but suitable for turnips. It is presumed that the heat which the dung possessed, and the subsequent decomposition that would take place, had infused life and vigour into the young plant, which thoroughly rotten dung does not possess; and, though it may ultimately raise us a good crop of turnips, it is at the expense of a great loss of bulk. The experience of the best cultivators in the northern parts of the kingdom is against the use of fresh dung; and neither Davy's lecture nor the recommendations of some of the greatest names of the day, have been able to alter that opinion. Fresh dung may answer on wheat fallows; but all dung will be the better for being laid together, turned, and fermented, so as to be easily separated and properly covered. (*Brit. Farm. Mag.*, vol. vi. p. 270.)

8367.—4990. *Meal from straw and hay* has been obtained by some French agriculturists, by cutting and afterwards grinding; and the meal, or rather bran, so produced, by facilitating mastication and digestion, is supposed to be better for old horses than straw or hay which is merely cut.

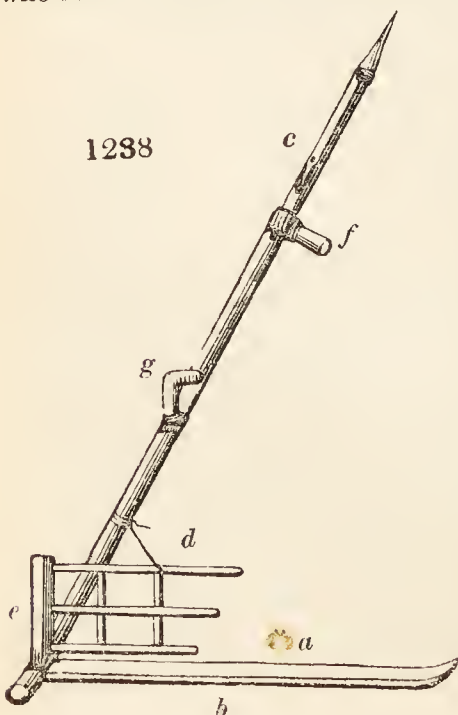
8368.—4992. *The advantages of cutting corn crops before they are dead ripe*; that is, when the straw immediately below the ear is just beginning to turn yellow, are thus summed up by Mr. Sheriff:—An increased quantity of grain, greater security from the weather, improved quality of straw, and an extension of the harvesting season. To these may be added, greater security against the effects of wind and rain, either as affects the shedding, discoloration, or germinating of the grain. The colour of grain which was not cut till it became dead ripe is generally of an opaque whitish hue; while that which was cut before it was dead ripe is transparent, and tinged with brown. The latter description of sample bears the highest price in most British markets. (*Brit. Farm. Mag.*, vol. v. p. 23.)

8369. *The period at which corn crops ought to be reaped* is best determined by examining the upper grains of the spikes. The cereal grasses, like all monocotyledonous plants, ripen the seeds on the upper extremity of their flowers, or even in the upper part of their seed-vessels, in the case of plants with pods containing many seeds; whereas dicotyledonous plants ripen their seeds equally throughout the seed-vessel, and in general rather ripen them first at the lower end than at the upper end. When the uppermost grain of a spike of corn has dropped out, the stalk may be considered as having stood rather too long, and the reaping point to be that when the uppermost grain is firm and plump. On the whole, the most improved practice of British farmers is in favour of reaping their crops at an earlier state of ripeness than they have hitherto been accustomed. (*Quart. Jour. Agr.*, vol. iv. p. 501.)

8370. *Cutting grain crops with a common scythe* has been generally practised in Aberdeenshire since 1818. The crops grown in this country are chiefly oats and barley. No change whatever is made in the common grass and clover scythe, for cutting heavy or lodged grain crops; but for light standing crops, a very simple addition is found of advantage. This consists of a small rod or shoot, nearly an inch in diameter, of green willow, or rowan (mountain ash), or broom, or any other flexible and tough young wood. It has its thick end twisted into the small iron rod, which aids in attaching the blade of the scythe to its handle, named provincially the grass-nail. Its small end passes over the upper side of the blade as far as the back, where it is bent upwards in an easy curve, and is brought backward, and tied with several rounds of strong twine to the handle, about fifteen inches above the blade. In cutting grain with a scythe, the swathe or cut corn is laid away from the standing corn. Every mower is attended by a gatherer; and, as the gathering is the part of the work that women can best perform, the gatherers are generally women. The grain is left by the scythe, having the stems forming an acute angle with the line of the standing corn, the root end of the stems pointing partly backwards and partly inwards towards the uncut part of the field. The gatherer places herself at the root end of the stems, so as to be able to stoop forward nearly in the line in which they are laid; and, by a succession of lifts with her hands, placing the corn on the rear over that which is more forward, stepping at the same time towards the right hand herself, she gathers into one heap what she deems sufficient for a sheaf, and, having carefully separated it with her right hand from the forward part of the swathe, then makes a band, in the ordinary way, of a part of the gathered heap, and lays the heap upon it. A binder is also attached to every mower, who is able to bind up all the sheaves cut by one scythe, and also to set them up in shocks; but there is no novelty in his operations. The gatherer and binder could generally, after a skilful mower, gather up all the corn sufficiently clean; but their labour would be greatly impeded, so as that they could not keep up with the scythe, were the cleanest gathering strictly enforced. That is, therefore, dispensed with; and a raker, generally a woman, follows the other operators, to collect the straggling ears and straws. (*Highland Soc. Trans.*, vol. x. p. 189.) The Rev. James Farquharson, speaking of this mode of reaping, says,—“In no branch of agricultural labour, not even in the substitution of the two-horse plough for the one drawn by ten oxen, or of the threshing-machine for the flail, has a more valuable advance been made, within our memory, from an old and inferior system to a new and better one, than in the adoption of scythe-reaping. It is calculated that double the work is done by the scythe, which could be performed in the same time by the sickle. It is also better performed; because the straw is cut off more closely to the ground, and consequently a better provision is made for cattle fodder during the winter, and for a larger quantity of manure. When the grain is over-ripe, much less is shaken out by the scythe than by the sickle. Another advantage, of which the magnitude can scarcely be believed, except by those who have learnt to estimate it by their own experience, is the quickness with which the mowed shock

wins (drys or withers) thoroughly, and becomes fit for the stack; a matter of the utmost importance in our unsteady climate. The straws are not crushed, as they frequently are with the hand in reaping with the sickle; and the sheaf, although not more liable to break out of the band, is more elastic and open to the action of the atmosphere. It is perhaps not too much to say, that a sheaf of equal weight, cut with the scythe, becomes ready for the stack, under equal circumstances of weather, in half the time needed by one cut with the sickle. The most pleasing advantage is the total change of the character of the labour, as it affects the larger part of the workpeople. The mowers, gatherers, and rakers deem their work delightful in comparison with the labour of the sickle.”

8371. *The scythe for reaping corn* (fig. 1238.) should have its blade (a) of the best steel, four feet long, strengthened by a plate of iron along the back (b). The handle should be straight, because that gives the greatest command over the scythe. A well-seasoned young larch tree, reduced to the proper thickness, with a slight curve at the root end, for receiving the blade in a proper position, makes the best handle to a reaping-scythe. A hone, covered with fine sand, and a fine sandstone, to whet the edge of the scythe, are hooked on to the handle at c, near its upper extremity. There should be a cradle (d, consisting of three long teeth, fastened to an upright stem (e), formed of ash, and as light as the strength of the wood will permit. The upper tooth should be a little more than two feet in length, and the two under ones should be, the first three inches, and the second six inches shorter. The upright stem of the cradle is driven into a socket of iron. The height of the cradle is about thirteen inches; the left-hand handle (f)



is straight, and the right-hand handle (g) is crooked. For the construction of this important instrument, further details will be found in the *Quart. Jour. of Agr.*, from which our figure is taken; but the above outline will suffice for any one who can construct a common scythe.

8372. *Corn of every description may be reaped with the scythe.* Oats make the most perfect work, with the greatest ease to all the labourers. Barley, with new grass, is not difficult to cut; but the clammy juice from the barley straw lubricates the scythe with a viscid coating like varnish, which must be rubbed off frequently with the whetstone. The binders have always hard work among barley. Wheat is beautifully laid in swath when mown. The takers-up and binders have less labour among wheat than the mowers, who must be powerful men to continue a length of time at the work; but there are modes of equalising the labour, and, of course, of diminishing the fatigue. For example: when a field of wheat and a field of oats are nearly ready for reaping, it is an excellent arrangement to reap the oats in the dewy mornings, before breakfast, or as long as there is any dampness on the corn, and then to go to the wheat, or to the barley, if there be little wheat on the farm, during the dry period of the day. By this plan much valuable time can be saved in reaping the whole crop. Oats are not the worse of being reaped in a damp state. It is a remarkable fact, that oats reaped in a damp state, with the scythe, will be nearly as soon ready for the stack as when reaped dry. Not so with barley. Shocks of oats which are reaped dry, but have afterwards been soaked with rain, will be longer before they are ready for the stacks than oats that have been reaped in a damp state. It is a still more remarkable fact, that damp oats reaped with the scythe will be sooner ready for the stack than would the same oats, reaped in a dry state, with the sickle. Oats reaped with the scythe will be quite ready for the stack in eight days, whereas oats reaped with the sickle require at least a fortnight. Shocks that have been reaped with the scythe will keep off much more rain than those reaped with the sickle. (*Quart. Jour.*, vol. iv. p. 366.)

8373.—5003. *Cone wheat*, a variety of *Triticum turgidum*, has been found by Mr. Gorrie to be but little injured by the wheat-fly, as this insect appears in the fly state much sooner than the wheat blossom bursts from the spathe. The grain of this variety is coarse; but every spike generally yields from seventy to ninety grains, which is double the number of the common wheat, *Triticum hybérnum*. It ripens about a week after the red wheat, and, when standing, is from a foot to eighteen inches taller than the common wheat. (*Quart. Jour. Agr.*, vol. iii. p. 641.)

8374. *Dantzig creeping wheat* is a variety cultivated on the borders of Scotland, which possesses the property of tillering, or throwing tap-shoots from the root in the autumn, in a remarkable degree. It originally came from Dantzig. (*Quart. Jour. Agr.*, vol. iv. p. 536.)

8375.—5042. *On the climate requisite to bring wheat to perfection.* Nothing is here said of altitude, latitude, or temperature. The highest altitude on which wheat will succeed on the banks of the Tay, is 450 feet above the level of the sea, where the mean temperature for the year is 46°. Wherever the annual mean temperature is below this, wheat cannot be raised with advantage. (*A. G.*)

8376.—5074. *Rye straw* is preferred to that of any other plant for littering horses; and rye is somewhat extensively cultivated about Newmarket for the sake of obtaining the straw for the livery stables. (*J. D.*)

8377.—5121. *The Hopetoun oat* is an accidental variety brought into notice by Mr. Sheriff in 1824. It is chiefly remarkable for its long reedy straw, which, in a crop of twenty acres in East Lothian, has averaged six feet in length, while the grain is thin in the husk, and nearly as short and plump as the grains of the potato oat. (*Trans. of Highland Soc.*, vol. viii. p. 362.)

8378.—5290. *The value of crops of Swedish turnips, potatoes, and mangold wurtzel, as food for cattle,* is not materially different, provided the crops are alike good of their kind. This is the opinion formed by an East Lothian farmer of great skill and experience, after having made a number of experiments to determine the value of these roots. (*Highland Soc. Trans.*, vol. ix. p. 273.)

8379.—5307. *Soil for the potato.* In the peninsula of Kintyre, the soil is calcareous clay, in which there is found gypsum, an earth said to be congenial to the potato; and there, Mr. Stewart states, that the potato crops far surpass any he had elsewhere seen, either in Scotland or Ireland. (*Brit. Farm. Mag.*, vol. vii. p. 479.)

8380.—5312. *Comparative produce of different modes of preparing the sets, and planting potatoes.* The following interesting experiments were made by the Messrs. Drummond of Stirling, with the Irish blue potato, on the same piece of ground, and under similar circumstances. The space which each experiment occupied was forty square yards, which were drilled and dunged at the rate of thirty tons the imperial acre. They were all planted on 28th May, and raised 12th October, 1832:—

8381. *The first plot* was planted on the plan recommended by Mr. Knight, Pres. Hort. Soc. The tubers were whole, weighing half a pound each, and were planted at the distance of six inches in the row, and the rows four feet apart, and lying north and south; forty square yards required nine pounds of sets, and produced 364 pounds of potatoes; being, per acre, 136 bushels of sets, and 550 bushels of produce: net increase, 414 bushels.

8382. *The second plot* was also planted with similar tubers to the last, at nine inches apart. The seed required weighed sixty pounds, the produce 326 pounds; being, per acre, ninety-one bushels of seed, and 493 bushels of crop; net increase, 402 bushels.

8383. *In both these plots* the plants were highly vigorous, and early in advance of others planted in the ordinary manner. The potatoes were not too large, but the crop contained a great proportion of small ones.

8384. *The third plot was planted* the same as the last, but the sets were cut of the common size. The seed required weighed only six pounds, the produce, 276 pounds; being, per acre, nine bushels of seed, and 417 of produce; nett increase, 408 bushels. The plants in this plot grew fast in the autumn, and produced by much the largest potatoes; but they did not ripen well.

8385. *The fourth plot was planted* with sets cut of the common size. The seed required weighed twelve pounds, and the produce 376 pounds; being, per acre, eighteen bushels of seed, and 568 of produce; net increase, 550 bushels. The potatoes in the produce of this last lot were the most equal sized.

8386. *The result of these experiments* (which were conducted with great care) is entirely contrary to Mr. Knight's theory, and consequent practice. (*Quart. Jour. Agr.*, vol. iv. p. 411.) In the *Transactions of the Horticultural Society*, second series, vol. i. p. 445. to 456. (published in August, 1834), an account is given of a number of experiments made with the greatest care and accuracy, under the direction of Professor Lindley, in the garden of the Horticultural Society, the result of which is conformable to that obtained by Messrs. Drummond. It also appears in the same work that Sir George Mackenzie made experiments of the same kind in Ross-shire, and found the produce decidedly better from sets than from whole potatoes. (See *Gard. Mag.*, vol. x. p. 433. 435. and p. 499.)

8387.—5328. *The uselessness of earthing up potatoes* has been pointed out by Mr. Hayward; and, independently of the effect of earthing up, and other operations between the rows, in destroying weeds and loosening the soil, we should think his practice the best. He says, that a farmer who simply hoed the soil between the rows of potatoes in one of his fields, had a much larger crop than he had in an adjoining field, where the rows were earthed up with the greatest care. A potato placed an inch only under the surface of the soil will produce a greater number of tubers than one planted at the depth of a foot. "I have no doubt," says Mr. Hayward, "if potatoes are planted shallow, and placed wide enough apart to admit of the stems being laid down after the young potatoes are formed; and if the earth between them was then thrown over five or six inches thick, so as to form a flat surface, that it would increase the crop. But this is a very different operation from that which I object to." (*Gard. Mag.*, vol. ix. p. 323.)

8388.—5337. *Benefit resulting from the removal of potato blossoms.* By a well-conducted experiment on a field of two acres, for which the honorary silver medal of the Highland Society was given, it appears that one third part of the field, being those drills from which the blossoms were plucked in the bud, pro-

duced thirty bolls, two bushels. One third part from which the blossoms were plucked when in full flower produced twenty-seven bolls, three bushels; and one third part, being those drills on which the plants were allowed to ripen their seed, produced twenty-six bolls. The difference here, in favour of plucking off the blossoms as soon as they appear, instead of allowing them to remain and ripen their seed, is nearly one sixth part of the produce. (*Highland Soc. Trans.*, vol. x. p. 237.)

8389. — 5354. *Potatoes may be preserved* by being rasped or ground to a pulp, afterwards pressed into dry cakes by Bramah's or any other powerful press, and then dried like cheeses. Potato cakes of this sort have been found to keep for years perfectly sweet; and, as a great deal of nutriment is thus put into very little bulk, it is thought by some that ships bound for long voyages might find it advantageous to lay in their stock of potatoes in this form. (*Quart. Jour. Agr.*, vol. iv. p. 483.)

8390. *Potato flour* was shown at Messrs. Drummonds' exhibition at Stirling in 1832, which was thirty-eight years old. It was made from damaged potatoes, which, it seems, answer as well as sound ones, and was in the finest condition. (*Quart. Jour. Agr.*, vol. iv. p. 414.)

8391. — 5360. *Potato haurm* forms a rich and excellent manure for wheat, at the rate of four acres of haurm to one of wheat, ploughed in green immediately before sowing the wheat. It is found decidedly superior to stable-yard dung. The mode of preparing it is simply to pull up the stems, and to avoid burying potatoes with it, however small they may be. (*A. Gorrie, in Country Times*, October, 1831.)

8392. — 5363. *Good beer can be produced from potatoes* by grating them to a pulp, mixing it well with boiling water, and then adding ground barley malt. The liquid, being drawn off, is to be hopped in the usual way, yeast added, and fermentation induced. The liquor thus produced, after being bottled, was found greatly to resemble the Paris beer. (*Dom. Econ. in Lardner's Cyclopædia.*)

8393. *Beer may be made from parsneps* in a similar manner to that from potatoes.

8394. — 5364. *The distillation of spirit from potatoes is thus practised in France*: — The potatoes are boiled by means of a steaming apparatus; and, where the apparatus is good, will be prepared sufficiently in ten minutes. As soon as they are in a proper state, they must be bruised when at as high a degree of temperature as possible, and then thrown, for the purpose of fermentation, into a tub or other vessel containing, for every 1000 pounds of potatoes, 416 $\frac{2}{3}$ pounds of cold water; the temperature of which, however, should not be below 14° of Reaumur (63 $\frac{1}{2}$ ° of Fahrenheit). The whole must then be covered up, and allowed to remain. There will be 750 pounds of sediment contained in the quantity of potatoes which has been mentioned; and this proportion, with the 416 $\frac{2}{3}$ pounds of water, will be quite sufficient to produce a mass, of which the consistency will be that of pap or curdled milk, and the temperature from 48° to 50° Reaumur. (140° to 144 $\frac{1}{2}$ ° Fahr.) There are then taken 31 $\frac{1}{4}$ pounds of the malt of barley, which is steeped in 250 pounds of water that has been previously heated to the height of 60° Reaumur. (167° of Fahr.), and the whole is allowed to remain until it shall have cooled to the temperature of 22° of Reaumur. (81 $\frac{1}{2}$ ° of Fahr.) There are then added 22 $\frac{1}{2}$ pounds of yeast, which is mixed by being actively stirred, and the whole is then well covered and allowed to remain. When the mass of fermenting potatoes is cooled to the temperature of 38° of Reaumur. (117 $\frac{1}{2}$ ° of Fahr.), the fermentation is stopped by adding 416 $\frac{2}{3}$ pounds of cold water, and the whole is well stirred together. This mass having fallen to the temperature of 25° Reaumur. (88 $\frac{1}{4}$ ° Fahr.), the prepared malt, which has already begun to ferment, is added; the whole is again well stirred together, the vessel very lightly covered, and the fermentation allowed to proceed. This latter operation takes place very regularly, and terminates in from forty-eight to sixty hours. The fermented mass assumes a spirituous odour, and furnishes, on distillation, so abundant a quantity of spirit, that, for every 100 pounds of potatoes, there are obtained eight French pints of spirit, in which, according to the scale of Richter, there are thirty per cent. of alcohol. If, before carrying the fermented mass to the still, it is passed through a sieve of iron wire of close meshes, the pulp of potatoes is kept back, and the spirit is then more pure, and more pleasant to the taste and smell. This will be still more the case, if there be added to this mass half a pound of potash for every 100 pounds of potatoes, before submitting it to distillation. If it is wished to have a spirit analogous to that obtained from wine, it must be rectified accordingly. (*Moléon's Recueil Industriel*, and *Quart. Jour. Agr.*, vol. iii. p. 321.)

8395. — 5377. *Dale's hybrid turnip* was originated, about 1828, by Mr. Robert Dale, of Libberton West, near Edinburgh. It is tankard-shaped, and resembles the Swedish or yellow turnip in colour. It is equal in size to the white globe, superior in size to most other varieties, whether of white, yellow, or Swedish turnips, and is found to produce a greater weight in a given space, and at a given expense of manure, than any other turnip hitherto introduced. It is not so hardy as the Swedish, and it runs to flower rather sooner in the spring; but, with these exceptions, it is the best of all field turnips. (*Quart. Jour. of Agr.*, vol. iii. p. 578.)

8396. — 5432. *Fly on turnips*. The following mode of prevention has been resorted to with success at Green Hammerton, Yorkshire. A board, about eighteen inches in breadth, and sufficiently long to cover four ridges of turnips, was made to run upon wheels, high enough to allow the board to pass over the turnips without touching the tops of them. The lower side of this board was painted with white paint, which the men provided themselves with, and took into the field, and during the night (at which time the fly is more injurious and destructive than during the day) the instrument was wheeled from one end of the field to the other. The insects, on being disturbed, of course immediately fly or jump up, and stick to the paint; and at the end of every set of ridges the board was almost covered with them. (*Leeds Mercury*, and *Report Don. Agr. Association.*)

8397. — 5453. *Carrot seed*. Messrs. Drummond, the eminent seedsmen of Stirling, state that the carrot crop in the field may almost always be insured, other circumstances being favourable, by bringing the seed to the point of vegetating before sowing. This is done by mixing it with sand or earth, kept moist, and turned occasionally for several days. They also recommend some nourishing compost to be placed under the seed in the drills, or sown along with it. They have made an experiment to prove that carrots may be grown to great advantage in peaty soil, and that they may be even grown in old worn-out garden soil, by mixing peat and dung together, and putting the compost thus formed in a gutter made by a wedge-shaped dibble, six inches wide at top, six or eight inches long, and at least a foot deep; the seed being sown immediately above the compost. (*Quart. Jour. of Agr.*, vol. iv. p. 410.)

8398. — 5516. *Symphytum asperrimum*, Mr. Gorrie observes, is assuredly liked by horses and cattle, and will soon recommend itself to the cottager and dairyman as a powerful auxiliary to clover, in summer and autumn. (*Highland Soc. Trans.*, vol. ix. p. 249.)

8399. — 5527. *Trifolium incarnatum* is considered in Italy as the earliest of clovers; as particularly calculated for dry soils, and as preferring the mountain to the plain. It is an annual, and succeeds best when sown in the autumn, after the corn crop has been removed. (*Quart. Jour. of Agr.*, vol. iii. p. 729.)

8400. *Trifolium elegans* is mentioned as worth culture, and seeds of it were shown at the Highland Society's exhibition in 1832. (*Farm. Jour.*, Oct. 4. 1830.)

8401. — 5550. *Clover* is dried in the hilly parts of Germany by resting it, immediately after being mown, against portable tressels, as corn is dried in Sweden and Norway. (*L'Agrologue*, vol. i. p. 136.)

8402. — 5643. *Old pasture compared with new*. John Boswell, Esq. of Kingcausie, Aberdeenshire, has long been of opinion that permanent pasture, instead of being a good thing, is a bad thing. After recapitulating his experience during several years, and strongly recommending thorough under-draining, deep ploughing and manuring, he concludes thus: — "I maintain, that, except a few favoured spots, such as banks of rivers, &c., no ground can, without loss, be left long in pasture; and that it appears to me, four or five years is, generally speaking, the longest period land should be allowed to lie in grass. If pasture be the object, at the end of that time the ground should be broken up as arable land, and then returned to grass again. I maintain, that without grass severely cropped land cannot be restored to full fertility; and without cropping, grass cannot be made to continue at the maximum point of verdure and utility.

Lastly, I maintain, no land, under any circumstances, ought to be cut in hay, if intended to remain some years in pasture; and, if cut as hay, every kind of land ought to be directly ploughed, and again put through the rotation." (*Quart. Jour. Agr.*, vol. iv. p. 790.)

8403. — 5647. *The great object of mixing different grass and herbage seeds together*, is to stock the surface of the soil at once so thickly with useful plants as to prevent weeds from rising up through them. Experience has proved that this cannot be done so effectually when only one or two species of grass or herbage seeds are employed, as when a greater number are made use of: and the reason appears to be found in the diversity of soils and situations. In general, the richer the soil the smaller will be the number of species which it will require. When the selection of grass seeds is judicious, there will be a constant succession of herbage kept up by them the whole year round, as grasses of several sorts grow at all times when the temperature is above the freezing point.

8404. — 5656. *The Italian rye grass*, Mr. Lawson found to be the same variety as Stickney's rye grass. It is considered superior to any other grass in producing winter herbage, and to be more hardy than the common rye grass. (*Highland Soc. Trans.*, vol. x. p. 28.)

8405. — 5717. *Number of kinds of grasses required in laying down permanent pasture*. A judicious writer in the *Quart. Jour. of Agr.* is of opinion that more of these grasses are brought into notice than their good properties will warrant. Independently of perennial rye grass and white clover, which must always occupy a large share of every permanent pasture, perhaps five or six of the others are all that are worth cultivation. It is true, many worthless grasses will grow up among our most carefully laid down pastures, and they, no doubt, assist in thickening the sward. But this is surely no adequate reason to sow them; and if it be necessary to sow a certain quantity of seed to cover the ground, that quantity should be composed of the best kinds. One reason for sowing a number of kinds is, that more plants will thrive closely together of different sorts than of the same sort. Allowing this to be the fact, there is still no necessity for incurring the trouble and expense of sowing worthless kinds, when a variety of them will grow naturally out of the soil to form a thick sward. Should the different kinds arrive successively at the different seasons when pasturage is required. It seems that $4\frac{1}{2}$ bushels will just furnish as many fertile seeds, that is, seven to the square inch, as there are plants in that space in a natural pasture: but if even more are required to render the pasture better, more of the best kinds only should be sown to insure the requisite thickness of sward. (*Quart. Jour. Agr.*, vol. iv. p. 414.)

8406. *Kinds and qualities of grass seeds for laying down land*. The most valuable article which has appeared on this subject since the publication of Sinclair's *Hortus Gramineus Woburnensis*, will be found in the *Quarterly Journal of Agriculture*, vol. iv. p. 714—724. This article is by Mr. Lawson, an eminent seedsman in Edinburgh; who, for a number of years, has directed his attention to the subject, with a degree of success which has been acknowledged by the first agriculturists in Scotland to be pre-eminently great. After giving a short description of thirty species or varieties of proper grasses, and eleven herbage plants, of which he has seeds for sale, he enumerates six other herbage plants, all Leguminosæ, the seeds of which are not yet articles of commerce, but which, he says, may be advantageously introduced into cultivation as soon as their seeds can be obtained. These are, *Lobus major*; *Vicia Cracca*, sèpium, and sylvatica; *Lathyrus pratensis*, and *Trifolium medium*.

8407. *Sowing the seeds of grasses and herbage plants by weight*, instead of the general practice of sowing the grasses by measure, and the clovers by weight, is strongly recommended by Mr. Lawson. "For, although in grass seeds the greater weight of one variety is no criterion of its superiority over another variety of less weight, yet a greater weight in the same variety always denotes a superior quality. Thus, when seed is light, and consequently inferior, the greatest number of seeds is obtained by adhering to a given weight; and hence there is the chance of nearly an equal number of plants springing up as when the seeds are plump and heavy. But a given weight of measure of seeds does not indicate the relative number of plants that will spring up; because there is both a difference in the relative bulk and specific gravity of seeds, and there is also a difference in the number of seeds that grow from a given quantity." (p. 719.)

8408. *The weight of the seeds of grasses*, per imperial bushel, is next given by Mr. Lawson; and the differences between the seeds of different species in this respect is most remarkable. Of thirty species, the heaviest appears to be the common perennial rye grass, a bushel of which weighs from eighteen to thirty pounds; and the next heaviest appears to be the crested dog's-tail grass, which weighs twenty-six pounds. The lightest seed is that of *Avèna* [*Trisetum*] *flavescens*, a bushel of which weighs only five pounds, and the next lightest is the meadow fox-tail grass, which weighs five pounds and a quarter. *Anthoxanthum odoratum*, and *Alopecurus geniculatus* weigh each six pounds; *Aira flexuosa*, six pounds and a quarter; *Poa glauca*, seven pounds and a half; *Elymus arenarius* and *Festuca duriuscula*, each nine pounds and a half; and the remaining species weigh from ten to sixteen pounds. Rye weighs 62 pounds the bushel.

8409. *The weights of clover and other herbage plants* are much less various. Burnet weighs twenty-four pounds and a half; saintfoin weighs twenty-six pounds; *Achillea millefolium*, twenty-eight pounds and a quarter; ribwort, fifty-one pounds and a half; *Medicago lupulina* (the nonsuch of English farmers, and the yellow clover of the Scotch) weighs sixty-three pounds and three quarters; and the different species of clover (*Trifolium*) from sixty-two to sixty-five pounds.

8410. *With reference to the culture of grasses in Britain*, Mr. Lawson observes that, wherever land produces the cereal grains and other cultivated plants, the pasture and herbage grasses will grow with vigour. Plants of this kind, he observes, are improved by different kinds of soils, and more especially with relation to their states of dryness or moisture. As a convenient arrangement for practical purposes, he classes all soils under light, medium, and heavy; and he has composed twelve different tables, each containing the quantity of grass seeds, per Scotch acre, for these three divisions of soils. Whoever, whether in Britain or America, wishes to sow grasses on a large scale, will find it worth their while to correspond with Mr. Lawson, with reference to the subject of these tables; because every year he is adding to his experience, and in all probability improving the selection. We shall, therefore, not copy them into our pages in detail, but merely give their titles, with a few remarks, chiefly with a view of showing how much greater the number of species is which Mr. Lawson recommends than what is commonly sown, and yet how much smaller is the quantity of seed per acre.

8411. *Grass and herbage seeds for alternate husbandry*. For one year's hay, twenty-two pounds of annual rye grass, ten pounds of red and two pounds of white clover. For one year's hay and one year's pasture, eight pounds of annual and eighteen pounds of perennial rye grass; three pounds of *Phlèum pratense*, five pounds of red and five pounds of white clover, and two pounds of nonsuch. For one year's hay and two years' pasture, twenty-eight pounds of perennial rye grass, two pounds of *Phlèum pratense*, two pounds of red, six pounds of white, two pounds of cow clover, and two pounds of nonsuch. These proportions are for soils suited for the turnip husbandry; in heavy soils, from two to four pounds of *Phlèum pratense* may be added for one year's grass.

8412. *Grasses and herbage plants for permanent pasture*. Of proper grasses, seven species are employed; of proper clovers, three species, and also the nonsuch. The proportions are given for laying down without a crop and also with a crop; and it is worthy of remark, that in the latter case the quantity required is not much above half what it is in the former. Without a crop, seventy-five pounds are required for a light soil, and eighty-two for a heavy soil; while with a crop, forty-one pounds and a half in the one case, and forty-five lbs. in the other, only are required.

8413. *Grasses, &c., for permanent pasture in ornamental parks*. Of proper grasses, fourteen species are employed, besides the clovers mentioned in the preceding paragraph. It is added, that *Achillea mille-*

folium may be added in dry soils ; saintfoin in dry calcareous soils ; wild endive in heavy soils ; and from one to two pounds of parsley per acre on lands where sheep are apt to get the rot.

8414. *Grasses and herbage plants for lawns, bowling-greens, &c., kept constantly under the scythe.* Of proper grasses, fifteen species are employed, together with the common white clover. On each soil, Pacey's perennial rye grass, more than one fourth part of the proper grasses, and the quantity of white clover per acre, varies from six to twelve pounds.

8415. *Grasses and herbage plants for grounds much shaded with trees.* Twelve species of proper grasses and white clover.

8416. *Grasses, &c., for heathy and moory lands which have been pared and burned, or scarified, for the purpose of producing herbage.* The following cheap mixture is recommended : — Mixed hay seeds twenty-five pounds, and white clover, six pounds, with a crop ; and forty pounds of mixed hay seeds, forty-five pounds of rye, and nine pounds of white clover, without a crop. When land of this description is situated 500 feet, and upwards, above the level of the sea, sheep's fescue and the two allied species, and *Poa glauca*, may be added, at the rate of two pounds each.

8417. *Grasses for improved deep peaty ground intended to lie in grass.* Perennial rye grass, ten pounds ; *Phlœum pratense*, eight pounds ; *Agrôstis stolonifera*, two pounds ; *Alopecurus pratensis*, two pounds ; and *Trifolium repens*, eight pounds, are recommended, when they are to be sown with a crop ; when without a crop, the proportions are, eighteen, twelve, three, three, and twelve pounds.

8418. *Grasses for land in preparation for irrigation.* We shall take the liberty, in this case, of copying the table verbatim : —

	Light Soil.		Medium Soil.		Heavy Soil.	
	With a Crop.	Without a Crop.	With a Crop.	Without a Crop.	With a Crop.	Without a Crop.
	Lbs.	Lbs.	Lbs.	Lbs.	Lbs.	Lbs.
Perennial rye grass	10	18	7	2	7	12
<i>Agrôstis stolonifera</i>	2	4	2	4	3	6
<i>Alopecurus pratensis</i>	2	4	3	6	4	8
<i>Festuca pratensis</i>	2	4	2	4	2	4
<i>Festuca loliacea</i>	4	7	4	7	4	7
<i>Poa trivialis</i>	2	4	2	4	3	6
<i>Poa fluitans</i>	1	2	2	4	2	4
<i>Phlœum pratense</i>	4	6	6	9	7	10
	27	49	28	50	32	57

8419. *Grasses for lands which are occasionally subject to the overflowing of lakes and rivers, or which are always in a very wet state.* These are, *Poa aquatica*, six pounds ; *Poa fluitans*, six pounds ; *Festuca loliacea*, four pounds ; *Phlœum pratense*, six pounds ; *Alopecurus geniculatus*, six pounds ; *Agrôstis stolonifera*, four pounds.

8420. *Grasses for rabbit warrens, or light sandy soils.* These are, perennial rye-grass, fourteen pounds ; *Anthoxanthum odoratum*, one pound ; *Festuca duriuscula*, one pound ; *Festuca ovina*, one pound ; *Festuca rubra*, one pound ; *Cynosurus cristatus*, two pounds ; *Potèrium Sanguisorba*, four pounds ; *Achillea millefolium*, half a pound ; *Trifolium repens*, six pounds ; *Trifolium minus vel procumbens*, two pounds ; *Medicago lupulina*, two pounds. If this mixture be sown without a crop, a bushel and a half of rye grass may be sown along with it.

8421. *For drifting sands, which are to be consolidated, and have a sward produced upon them by sowing.* These are, *Elymus arenarius*, ten pounds, which should be mixed with clay and straw ropes cut into pieces, and dibbled into the sand. After a sward has been produced, the mixture recommended for rabbit-warrens, or light sandy soils, may be sown.

8422. *For dry gravelly situations, which resist a sward from all ordinary means.* These soils may be sown with *Agrôstis vulgaris*, two pounds ; *Poa annua*, four pounds ; *Briza media*, four pounds ; *Aira flexuosa*, one pound ; *Trifolium minus vel procumbens*. We repeat our strong recommendation of Mr. Lawson, as an agricultural seedsman, to all persons residing near Edinburgh who have lands to lay down in grass. We are not less anxious to recommend Messrs. Drummonds of Stirling ; Messrs. Dickson and Turnbull of Perth ; Messrs. Cormack and Son, and Mr. Gibbs, of London ; and M. Vilmorin, of Paris, to all those similarly circumstanced in their respective localities.

8423. *Mixtures of grasses for the alternate husbandry.* From the result of an experiment made by Mr. Shireff of Mungoswells (*Quart. Jour. Agr.*, vol. ii. p. 242.), it appears decidedly preferable to use a mixture of seeds, even where a single crop of hay, to be succeeded by a year's pasturage, is to be taken. The grasses sown were cock's-foot, hard fescue, cat's-tail, rye grass, and red, white, and yellow clover. "The rye grass was conspicuous for growing early in spring as well as late in autumn, and remaining comparatively unproductive in the summer months. The cock's-foot, throughout the season, put forth new leaves with rapidity, after being cut with the scythe, and produced culms to the hay crop only ; the fescue planted thinly, and also grew rapidly after being cut ; the cat's-tail was later in producing flower-stalks than the other grasses used in the experiment, and, after being cut, did not put forth new leaves so rapidly as the cock's-foot and fescue ; but, in every instance, it produced numerous culms, white blossomed, at the same time as the red clover ; and, where a part of the field was four times mown, yielded a rich crop of culms to the last. The produce, as compared with that of clover and rye grass only, sown in the same field in the same season, was about a ninth part greater, and the extra-expenses of the seed about a fifteenth part. Had the clover failed to grow along with the rye grass, as it frequently does, the difference in the produce would have been much greater. The great advantage of a numerous combination of grasses is, that the failure of a crop is rendered next to impossible. It is also found that a mixture of grasses is less injurious to the succeeding corn crop than rye grass only. The family of grasses, Mr. Shireff observes, forms a useful class of machinery in the manufacture of productions for the dairy, the shambles, and the manufacturer of clothing ; but, in order to take advantage of the raw materials, air and moisture, so bountifully supplied by nature, the most efficient machinery must be employed. The husbandman who clothes his fields only with rye-grass and clover employs a limited machinery, the former being unproductive in summer, the latter moderately so in spring ; but when he, for this purpose, uses a variety of plants, differing in their habits of growth and periods of luxuriance, a numerous and powerful machinery is kept successively in full operation.

8424. *Poa nemoralis* was found by Mr. Taunton to produce a thick sward in plantations where every other grass was killed. He says, "its rich nutritive quality, its beautiful and perpetual verdure, and, above all, its quality of flourishing under a dense cover of trees, appear to me to render it peculiarly valuable for the particular purpose of rendering ornamental, and also of turning to a profit, the site of grown-up plantations and thick groves, which are, usually, in a state of complete nakedness." (*Quart. Jour. of Agr.*, vol. iii. p. 413.)

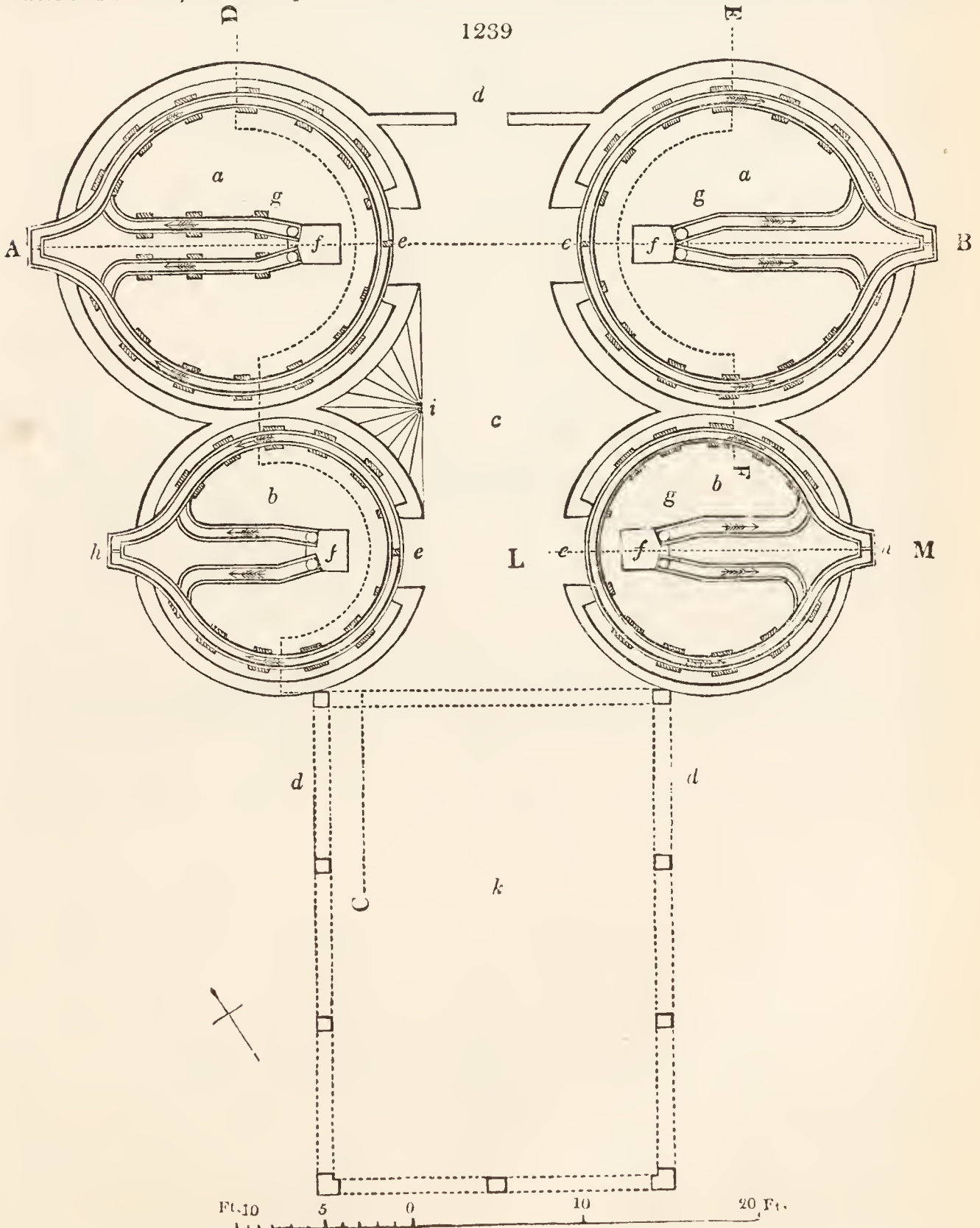
8425. — 5820. *To destroy moss in old turf.* "It is a singular fact, but not generally known to agriculturists, that by merely lifting the turf of an old pasture field that is overrun with moss, and ploughing and loosening the subsoil, and then laying the same turf down again, the whole of the moss will disap-

pear the first season, without applying either water or manure to the surface." (*Stephens on Irrigation and Draining*, p. 59.)

8426. *Renovating defective meadows.* The late Mr. Sinclair, of the New Cross Nursery, had perhaps more experience, as he certainly had more science and skill, in this department than any other man. In his excellent work the *Hortus Gramineus Woburnensis*, he recommends first ascertaining that the meadow is completely under-drained; then stirring the surface, by harrowing it, in all directions; the best harrow for which is unquestionably that of Finlayson. After this, he gives a thorough top-dressing of rich finely divided compost; he again harrows and cross harrows, and then sows from two to six pecks per acre of grass and clover seeds. For a meadow of low rich alluvial soil, he employs meadow fox-tail, meadow cats-tail, meadow fescue, rough-stalk meadow grass, crested dog's-tail grass, sweet-scented vernal grass, and perennial red clover. In two years such a meadow will be thoroughly renovated, and will bear abundant crops of hay.

8427. — 6041. *The process of drying hops* is as follows: — After being gathered from the bine, or stalk, the flowers are immediately carried in bags to the kiln, on which they are spread out to the thickness of from six to ten inches all over the surface of the kiln. The fire is then lighted, and kept burning briskly night and day, so long as there are any hops ready to be dried. It is found that a kiln of Mr. Read's construction may be charged once in every twelve hours. After the hops are dried, they are swept off the kiln into a cool ventilated loft adjoining, and generally attached to it, this loft being formed over a cart-shed, or some other building open on one or all sides. Being cooled here for a day or more, or according to convenience, the hops are bagged or pocketed; the bag weighing $200\frac{1}{2}$ cwt., and the pocket $100\frac{1}{2}$ cwt.; that is, packed in bags, which are suspended by a hoop from a round opening in the floor, and into each of which a man enters, to consolidate the hops by treading them down. When the bag is full, it is released from the hoop, and pulled up, still being retained over the hole, till it is beaten into shape, when it is sewn up, and let down into the shed, whence it is carried to market, or to the store loft, where it may be kept a year or more, if carefully excluded from the air. Hops dried on Mr. Read's kiln have been known to keep four or five years; but those dried by the common methods, and especially those of Farnham, seldom keep even twelve months, from the imperfect manner in which the process

1239

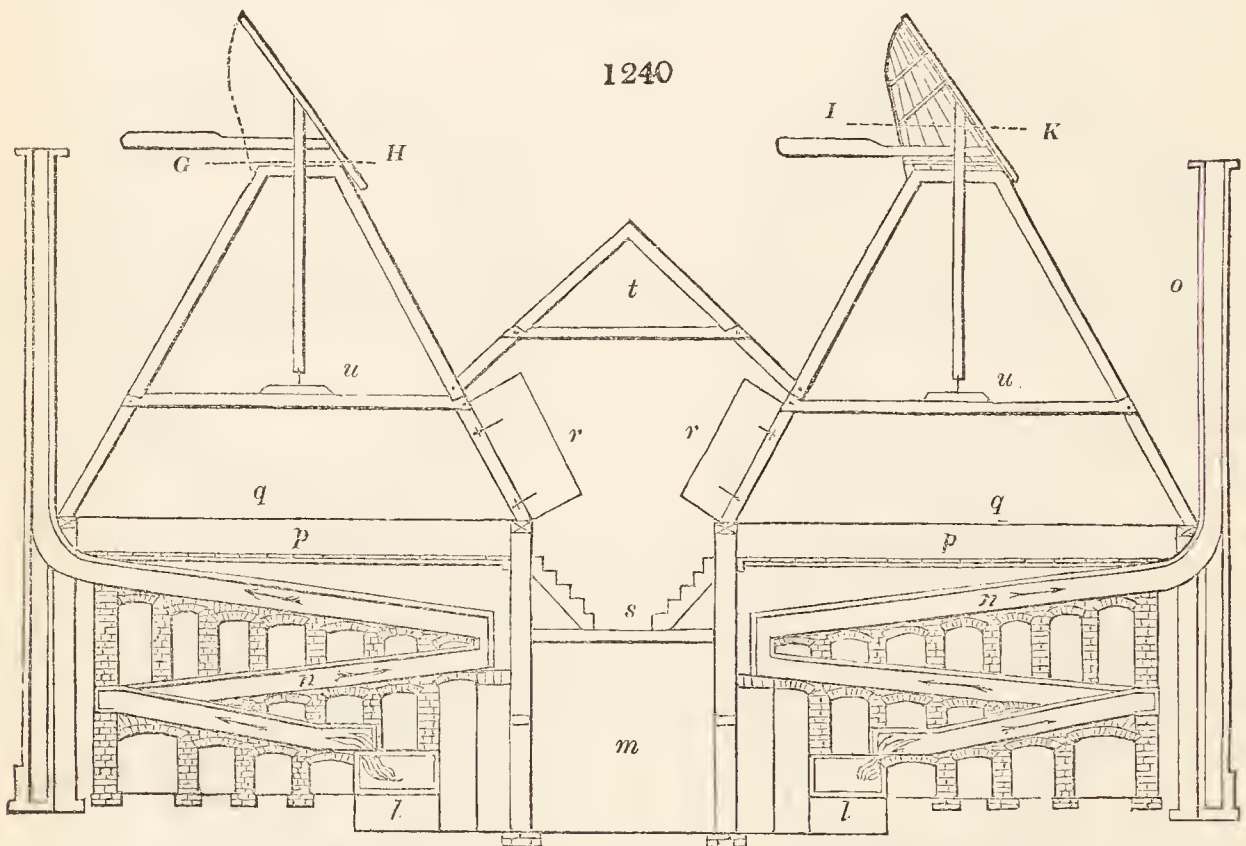


of drying has been performed. There are several excise regulations connected with the drying of hops in Britain, which we think it unnecessary to enter into a work intended for both hemispheres; more especially as we anticipate the entire removal of the excise duties, and the substitution of a graduated per centage or property tax for this and all other government taxes.

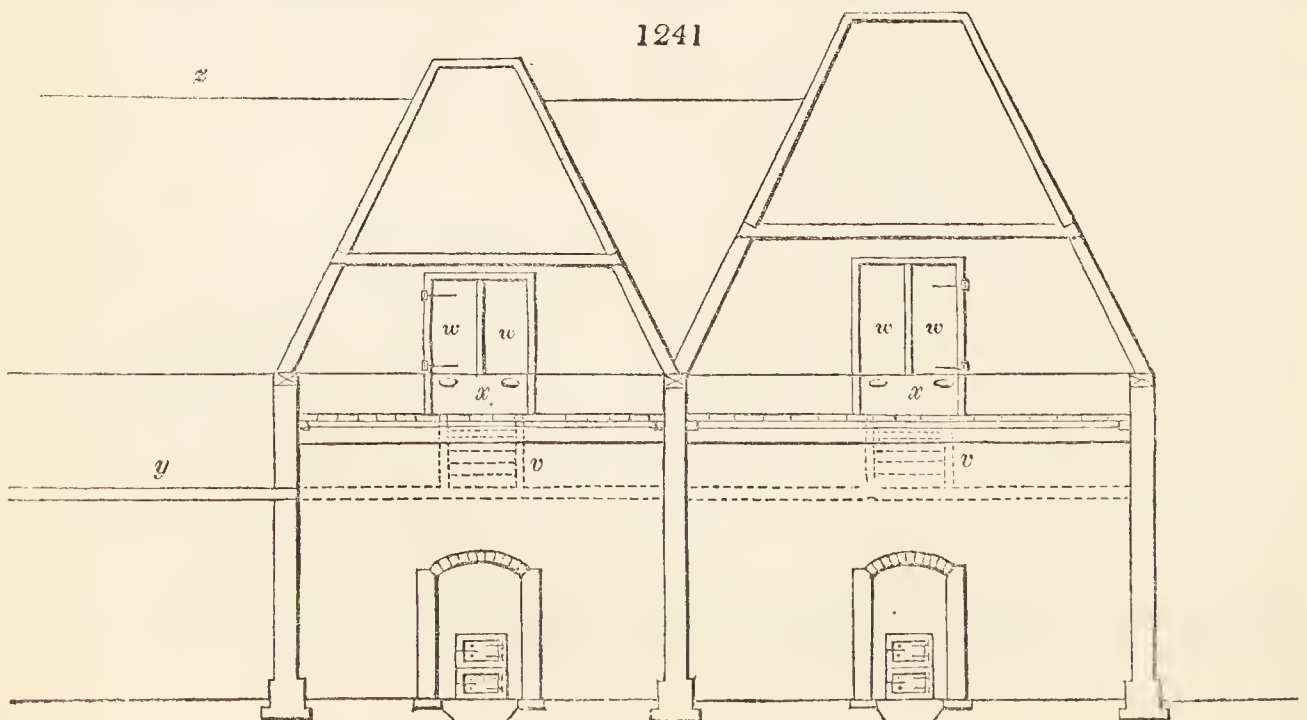
8428. *The situation of a hop-oast* ought to be airy; and the external opening to it, for the admission of the air, ought to face that point of the compass from which the wind blows most frequently at that season of the year when hops are being dried. In England, the hop harvest is in the month of September, and the wind in that month is generally in the direction of the south-west. When several kilns are built together, and not in a straight line, but so as to form two rows or a group, as in *fig. 1239*, this rule cannot be followed; but the next best rule is, to have the openings to the fireplaces facing the north-west and south-east, by which means they will catch a part of the current from the south-west as it passes.

8429. *The circular form* for the kiln has been adopted by Mr. Read, because it contains a greater area than any other figure with the same quantity of exterior walling; and, because both the walls and roof can be made stronger than they can in any rectangular form, with fewer materials. Hence, while the circular kilns possess more strength and durability than the rectangular ones, the expense of construction is less.

8430. *Details of the oasts erected at Teston.* *Fig. 1239.* is the ground-plan; in which *a a* are two kilns, twenty feet in diameter internally; and *b b* two other kilns, sixteen feet in diameter internally; *c* is an open space between the kilns, to which air is freely admitted by the openings to the south-east, south-west, and to the north-east, at *d d d*; *e* shows the openings to the dunge, and cockles or furnaces for the admission of air to the fire, and to be rarified by the flues, previously to its ascending and passing through the drying floor; *f*, the furnaces, made of cast iron, with doors to the fuel-chambers and ash-pits of the same material; *g*, termination of a portion, to the extent of one yard, of the flues next the furnaces, which ought to be built of fire brick, or which may be formed entirely of cast iron, as in this design. The remaining part of the flues to be built of common brick on edge three courses deep, and covered with bricks or tiles, twelve inches long by six inches broad; *h*, the situation of the chimney-shafts; *i*, the staircase for carrying up the hops to the drying-floor; and *k*, a cart-shed, over which is a floor on which the hops are cooled. *Fig. 1240.* is a transverse section on the line *A B*, or nearly so, in which *l* is the fuel-

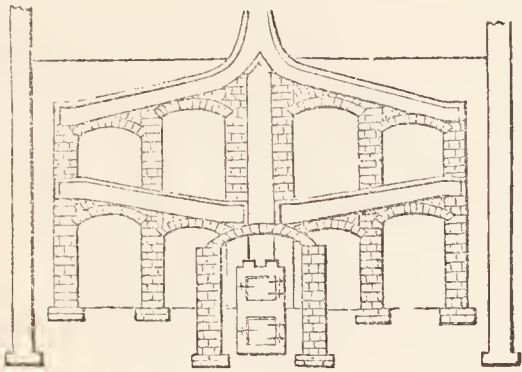


chamber, with the doors open; *m*, the thoroughfare between the two kilns; *n*, the flues; *o*, the chimney-shafts; *p*, the drying-floor; *q*, the situation of the wall-plate; *r*, the doors to the drying-floor open; *s*, the floor of the loft, with the movable stairs to the drying-floor; *t*, the roof of the cooling-loft; and *u*, collar beams for supporting the spindle of the cowl. *Fig. 1241.* is a longitudinal section on the line *c d*, in

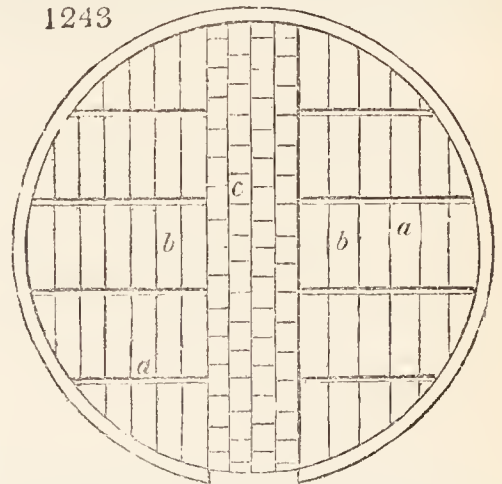


which *v v* show the situation of the movable steps from the common floor of the passage left, and cooling-room, to the double doors, *w*, of the drying-floor; *x*, bottom boards of the doors, eighteen inches deep, which fit into grooves, and have two holes in each for lifting them up every time the drying-floor is to be emptied. While this operation is going on, the step ladders are removed, and the hops are swept through the door, and fall down into the passage loft, where they are swept along to the cooling chamber; *z* is the ridge of the roof from the cooling chamber and passage loft. Fig. 1242. is a cross section of one of the larger kilns on the line *E F*, for the purpose of showing the returns of the flues, from the centre to the sides in the lower part of the dunge, and from the sides to the chimney-shaft in the upper part of the dunge. Fig. 1243. is a dissected plan of the drying-floor, in which *a a* are the iron girders, the strength

1242



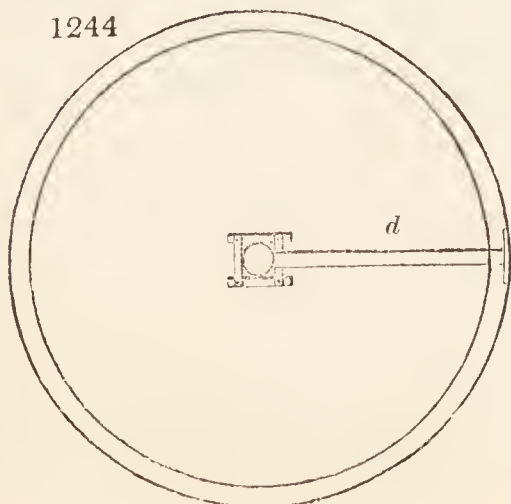
1243



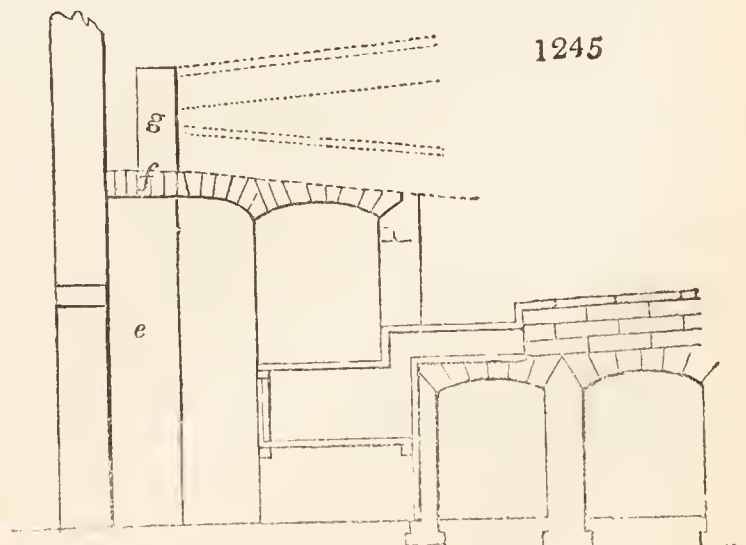
of which may either be such as to require no supports between the ends, or they may be so slight as to require one or more pillars as props between the extremities; when they are of cast iron, they may be in two lengths, four inches deep in the middle, and half an inch thick, each length of sixteen feet, supported by two iron columns: *b b* are the laths, which may be either of cast or wrought iron; when of cast iron, they are four feet long, roach-bellied, that is, forming the segment of a circle on the under side, two inches broad at top, and a quarter of an inch on the under edge; when they are of wrought iron, they are one inch and a half broad (that breadth being necessary to form a bed for the tiles), and half an inch deep; in this case the extended length across the girders is from one of the kilns to the other: *c c* are the tiles pierced with holes, in the same manner as the tiles of malt kilns.

8431. *Construction.* The exterior walls are of brick, with eighteen-inch footings, and are carried up a foot or more of the width of fourteen inches, after which their width is nine inches, up to the eaves of the roof, which are eighteen inches above the drying-floor. The rafters are four inches by two inches at the bottom; and three inches by one inch and a half at the top, where they shut against a circular curb or rim under the cowl. The furnaces or fuel-chambers are entirely of cast iron, and the ash-pits have iron doors. At the farther extremity of the fuel-chamber there is an opening six inches square at top, through which the smoke and heat ascend into the flue. The flue for the first three or four feet is either built of firebrick, or formed entirely of cast iron, six inches in diameter; after which its sides are formed of three bricks on edge, not plastered either outside or inside; and its top is covered with two courses of tiles, breaking joint, six inches by three inches. The reason why narrow tiles are chosen is, that duty is saved; and two courses breaking joint are employed, in order to prevent the risk of smoke getting through the joints into the dunge. The flues are supported by piers formed of open brickwork on edge, and joined by arches four inches in thickness, bevelled on the top, so as to form the base of the flue. Two flues proceed from each fireplace, ascending at an angle of 15°, or more if the height of the dunge will permit, in the direction indicated by the arrows, meeting at *e*, in the plan *fig. 1239.* and each there returning over itself, and again meeting at the chimney-shaft, *h.* These flues may be easily cleaned by the removal, at short distances, of some of the covering tiles; or, what is a simpler mode, by burning in the fuel-chamber a few handfuls of dry brushwood, or dried hop-bine, or any thing that will quickly create such a draught as will carry all the soot in the course of a few minutes out at the chimney top. About London the washerwomen clean the chimneys of their boilers on the same principle, by throwing in, in rapid succession, small quantities of gunpowder. The cowl should project about a foot on every side over the orifice in the summit. This orifice is, to that for the admission of air to the dunge, as one to one and a quarter. In the building of the walls of the kiln, in order to preserve them truly circular, an upright pole is fixed in the centre, and a guide-rod, *fig. 1244. d,* is framed on to it, of the requisite radius. The lower end of the central perpendicular pole is fixed in the ground, and the top kept steady by braces to other poles outside the circumference of the plan, so as not to interrupt the free evolution of the guide-rod. For every course of bricks laid on the wall, a course is also laid in mortar round the upright pole under the guide-rod, so that the latter is always kept level. So rapidly can bricks be laid in this manner, that Mr. Read finds such walling cost less than straight brickwork. The course of bricks immediately under the flooring tiles, twenty inches from the top, ought to project an inch inwards, for the tiles to rest on. The exterior opening to the dunge should be kept low, it being found that when this is the case the draught is always greatest; its height need never exceed four feet six inches, which is sufficiently high to admit a person to enter the dunge. When the manager of the furnace is once within, he immediately finds six feet of head-room; there being a pier, *e,* nine inches by eighteen inches, carried up on each side of the door, along with the outside wall, as in *fig. 1245,* which is a section on the line

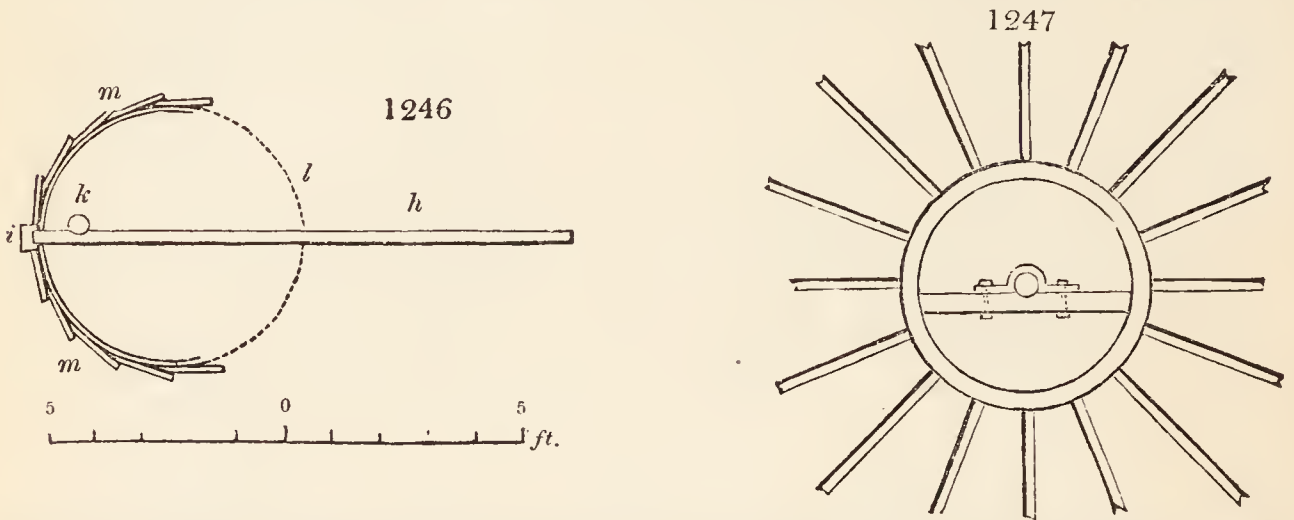
1244



1245



l m, for the purpose of forming abutments for the four-inch arch, *f*, which carries the double flue, the end of which, at the point where one returns on the other, is shown at *g*. The furnace and flues should be blackened exteriorly, in order to increase the radiation of heat, and the inside of the surrounding walls ought to be whitewashed, to prevent them as much as possible from absorbing it. The cowl moves altogether independently of the curb which forms the opening under it: it consists of one strong back piece, into which the upright spindle is framed, as may be seen in the section, *fig. 1240*, at *i*. Attached to the spindle and the back-board is the fly-board, *fig. 1246. h*, which serves, like a rudder, to keep the back of the cowl to the wind. The boards forming the cowl overlap each other from the back piece, or rib, towards the sides; and they are nailed to iron hoops, as indicated in the section *i k*, *fig. 1246.*, and also in the section, *fig. 1240*. In the former section, *h* is the fly-board; *i*, the back rib; *k*, the upright spindle; *l*, the iron hoop; and *m*, the boarding. *Fig. 1247.*, which is a section on the line *G H*, shows the



manner in which the upright spindle works against a collar-piece, which is fixed across the centre of the curb, at the kiln top. This piece being fixed, and the collar containing the spindle bolted on it, the bottom piece, in which the pivot of the spindle works, can, before it is fixed, be moved backwards and forwards on the collar beam, till the spindle is brought to a perfectly upright position and made to work freely.

8432. *Remarks.* The great superiority of the circular kiln to that described in the preceding design is so obvious that we only wonder, considering that it has been extensively used in Kent and Sussex for upwards of thirty years, that it has not found its way everywhere. It must be obvious that not only any description of fuel may be used in Mr. Read's kilns, but that, from the great length of the flues, a much greater quantity of heat will be rendered available for passing through the drying-floor. The circumstance of the flues ascending at a considerable slope is highly favourable for promoting a draught, and consequently for thoroughly consuming the fuel. Mr. Read informs us, that he has superintended the erection of some hundreds of these kilns; and that in one year he erected seventy, all within the counties of Kent and Sussex. This being the case, it strikes us with astonishment that Mr. Read's improvement has not been adopted by the hop-growers of either Farnham or Worcestershire, and the proprietors of malt kilns everywhere.

8433. "*Buckwheat* is ground generally into grits by means of handmills, or lever hammers, and is made either coarse or fine. The coarse sort is used for gruel, and the fine sort for cakes and biscuits. In some places they even make use of the first grinding with the bran, more or less, in addition to the finer flour, for baking household bread. It also serves to fatten hogs or poultry in a short time. The principal method to cleanse and separate the husk is, to pour boiling water on a given quantity of cleaned buckwheat, to stir the mass about with a stick, and draw the water off, then to pour cold water upon it, having first stirred it about well. In a quarter of an hour after, the buckwheat is taken out with the hands, and the water squeezed out. In the summer it is dried in the sunshine, and in winter in a warm room, and spread on the floor. As soon as it is quite dry, it is ground in a hand-mill or a stamping-machine into grits, in which state it is very clean and tasteful. The flour obtained from the sieve is dainty and very fit for cakes," &c. (*Com. Board Agr.*, vol. i.)

8434. — 6594. *A machine for fixing horses while being shod*, of a simple and effective description, has recently been invented by Mr. James Catcleugh, millwright in Haddington, a mechanic of very great genius; which will be found described and figured in the *Quart. Jour. Agr.*, vol. iii. p. 510.

8435. — 6684. *The following plan of feeding horses* has been practised by Dr. Sully of Wiveliscombe, in Somersetshire, for upwards of twenty years. In Dr. Sully's stables there are no racks for holding hay; for in his opinion a horse with a well-filled rack will consume and spoil upwards of thirty pounds of hay in twenty-four hours; whereas, if the hay were cut down, and mixed with a due proportion of cut straw, and bruised or coarsely-ground oats or other grain, ten pounds are sufficient. In the loft, above the horses, Dr. Sully has prepared proportionable quantities of the food with which his horses are daily supplied; and a very simple method has been devised to convey it, when mixed, to the manger of each horse. A wooden pipe is made to pass from the loft into each of the mangers, and close by the mouth of the pipe, in the loft, is placed a tub, of size enough to contain what is sufficient food for a horse for twenty-four hours. To prevent the horse, in searching for grain, from tossing out of the manger the mixed food which is dropped into it, oak crossbars twelve inches distant, are nailed over it; between these bars ample space remains for the horse to feed. As there can be no dependence on the measured quantities of grain or other food given to the horse, from the variation at times in the respective weights of equal quantities, Dr. Sully recommends, and, indeed, regards it as necessary, that grain of all kinds, and also the cut hay and straw, should be carefully weighed. When all the ingredients are so prepared, the proportions for each horse are allotted. From the following table will be seen the different articles of food, and the quantities and weight of each, which the horses should receive:—

	1st class. lbs.	2d class. lbs.	3d class. lbs.	4th class. 1 s.
1. Farinaceous substances, consisting of bruised or ground beans, peas, wheat, barley, or oats	5	5	10	5
2. Bran, fine or coarse	-	-	-	7
3. Boiled or steamed potatoes, mashed in a tub with a wooden bruiser	5	5	-	-
4. Fresh grains (boiled barley)	6	-	-	-
5. Hay cut down into chaff	7	8	10	8
6. Straw cut down into chaff	7	10	10	8
7. Malt dust, or ground oilcake	-	2	-	2
	30	30	30	30

With two ounces of salt for each class. By this table it will be seen that each horse receives thirty pounds of food in the twenty-four hours, a quantity that will in all cases be found to be amply sufficient. The addition of two ounces of salt is necessary to assist the digestion of the food. Of the four classes into which Dr. Sully divides his ingredients for feeding, those two which contain the steamed or boiled potatoes are the most recommended. No food conduces more to the healthy working condition of horses than the steamed or boiled potatoes; and we may observe, with relation to this, as well as to other kinds of food, that, when the horse comes in weary and hungry, after a long day's work, it is necessary to fill his manger more copiously with the ingredients prepared for him. Dr. Sully and all the other persons who have devised improved methods of feeding agree in the practices of bruising or coarsely grinding the grain and beans, of cutting down the hay and straw, of giving no hay in the rack, of allowing salt, and of weighing each article separately before mixture, instead of adopting the fallacious guide of measurement. (*Quart. Jour. of Agr.*, vol. ii. p. 727.)

8436. *Road horses*, in some parts of Scotland, and more especially in the neighbourhood of Edinburgh and Glasgow, are fed on equal parts of oat-straw and hay, cut by a machine in the lengths of from one eighth to one sixteenth of an inch. The cut straw and hay so produced are intimately mixed together, and, when musty, sometimes sprinkled with a little salt and water. The drink given to the horses is water in which oats or barley have been boiled, and the grain so boiled is found to equal double its quantity of raw grain in keeping horses in condition.

8437.—6852. *Feeding horned cattle on raw, or on steamed or boiled, food.* Though boiled corn is found to be doubly nutritious to horses, yet, from a number of experiments made by practical farmers, with a view of obtaining the premium of thirty sovereigns offered by the Highland Society of Scotland, it has been given as an opinion, that, in the case of the ruminating animals, no advantage whatever results from cooking their food. (See *High. Soc. Trans.*, vol. x. p. 253.)

8438.—6856. *On the treatment of cattle in winter.* An excellent paper on this subject will be found in the *Quarterly Journal of Agriculture*, vol. ii. p. 228—241. Some difference of opinion exists among agricultural writers as to whether young growing cattle ought to be fed, or pampered as Dr. Coventry calls it, with rich food, or supplied with abundance of coarser food. The writer of the article referred to inclines to the former opinion, on the principle of its being the farmer's interest to treat his cattle in such a way as shall enable him to bring them soonest to market. Coarse food, he says, ought not to be found on a well-cultivated farm. Straw and water, in an agricultural sense, are not food at all. Straw given to cattle, with a view of being consumed as their only food, is just so much straw wasted, and time lost, in the forwarding of their condition. A limited supply of turnips will keep cattle alive, and may prevent them from falling off in flesh, but it will never bring them to a state of fatness, though they were to eat in that manner for any length of time; whereas a moderate quantity beyond this limited portion would constitute abundance. Scanty food renders cattle uneasy; whereas food in abundance renders them contented and able to endure every inclemency of weather. A farmer ought neither to rear nor purchase more cattle than he has food sufficient to keep in affluence; for though this might lessen the number, both on individual farms and in the country generally, yet the quantity of butchers' meat brought to market would be greater, and its quality better, than it now is. Hence, on the score of profit to the farmer, and ease and comfort to the cattle themselves, abundant nourishment ought to be given to the latter from the earliest period of their existence, until their growth is complete. Cattle may be fed in houses, and tied to stakes, or in what are provincially called "hammels," which are small open courts, with an open shed for shelter on the north side. Twenty calves, or ten yearlings, may be put into one of these hammels. A hammel with a shed seventeen feet in width, and fourteen feet in depth, with a court twenty-one feet by seventeen feet, will contain three large oxen, or four smaller-sized cattle. Every hammel must be supplied with pure water at the command of the cattle. Before the cattle are put into hammels or byres, the floors ought to be well littered, so as to form a sort of drain to carry off the urine to an underground tank, whence it may be pumped up for use. Cattle fed on turnips eat very little straw; and therefore, the first thing that should be given to them, in the morning, is turnips; the troughs for holding them having been previously cleaned out. In the byre, the first thing to be done in the morning is to draw the dung from behind the cattle into the urine canal; and while the cattle are eating their turnips, the dung can be wheeled to the dunghill. Fresh straw, for fodder, may be given about the time that the turnips are eaten up, a small quantity being placed before each beast in the byre, and in the racks under the sheds of the courts. Oat-straw is found to constitute the best fodder for cattle; potato oat-straw is, perhaps, better than that of the common oat, as the former is always cut down before it is quite ripe. Hay is, no doubt, better than any kind of straw; and those who have abundance of that desirable fodder may give it ungrudgingly to cattle, in the certainty of being soon repaid its value. Turnips should be given again about mid-day; and about three o'clock in the afternoon the mangers should be cleared out, and straw or chaff given. In the byre, after this allowance is eaten up, the mangers should be cleaned out before giving another foddering of straw. A trowel will be found a handy instrument for this purpose. At the hammels, the last foddering of straw can be given any time after the last allowance of turnips, which should be ample, as the cattle will come backward and forward to them even in the dark, and in moonlight they will feed as well as during the day. The calves should be served with turnips immediately after the feeding-beasts; and the year-olds can also get a few at this time, to complete their day's allowance. Between the allowances of turnips, litter should be sprinkled in the byres and hammels, to induce the cattle to lie down after repletion, to chew the cud, which they will invariably do. At eight o'clock at night, the byres should be looked at with a light, and the cattle supplied with the fodder necessary, and their beds made comfortable, for the night, by drawing back any dung that may be on them, sprinkling some more litter, and shaking it well up with a fork. At the hammels, if it is moonlight, some more turnips should be thrown, even at this time of night, into the mangers. During the day, the water-troughs should be all kept full of fresh water, and any filth that may have been blown into them by the wind should be removed. When the frost becomes so severe as to harden the turnips, they should no longer be brought from the field, but from the store formed of them in the beginning of winter, for the purpose of supplying the cattle with fresh turnips during the continuance of frosty weather; nor should any more be taken even from the store than what can be consumed in a day. Frozen turnips may be thawed by being placed in a tub of cold water; but this is a very tedious and troublesome mode of obtaining fresh turnips in frosty weather, compared to the excellent practice of storing a considerable quantity in open weather.

8439. *In the feeding of cattle*, it is of the utmost importance that the man who has the charge of them should be very attentive to his duty; and, in particular, that he should be exact, even to a minute, in supplying them with turnips: cattle know perfectly well when the time arrives for a fresh supply, even though the mangers in the hammels may not be empty, which they should never altogether be. When they are supplied with food at irregular times, they will either be always craving it, or become careless about it; and their uneasiness, arising from frequent disappointments, will prevent them from feeding so pleasantly and speedily as when their food is placed before them at exact periods. When the man thus regulates his different works by time, he will find leisure moments during the day to perform many necessary acts; which, though they may appear of little importance in themselves, nevertheless contribute greatly to the appearance of neatness and comfort in the farm-yard and its inmates. Thus, he might spread the stable-litter along the edge of the turnip-troughs of the year-old cattle, to keep any turnips clean that may have been pulled over by the beasts; for, when cattle are first put up to feed, the freshness and tenderness of the leaves induce them to eat these first, and in the anxiety of each to obtain another fresh bite, many turnips are necessarily turned over. The man can also shovel and scrape together any mud about the causeways, and the places on which the turnips have been laid down from

the field. He can frequently examine the skins of the cattle, and give immediate notice of any eruption; for cattle, after being a month or six weeks on turnips, get very itchy in the skin, the violent rubbing of which often causes ulcerated spots to break out, but which can easily enough be cured at first, by an application of a decoction of tobacco, with a little spirit of tar. He should rub those parts of the body which they cannot easily get at to lick with an old currycomb, and scrape off any dung that may adhere to the hair in the hinder and under parts of the body, with a large blunt knife; and this attention is more necessary at the beginning of the season than afterwards, as the freshness of the stems, and the juiciness of the roots of the turnips, and the greediness which all cattle evince for them at first, often cause a looseness in their bowels. He should observe the first indication of lice in their skins in the early part of the spring, when these may be easily destroyed, by applying to the affected parts a solution of mercurial ointment; but, if neglected, they will cause much uneasiness to the cattle, making their hair peel off, and exposing to view an unsightly skin; and he may handle them frequently on every part of their body, as they are very fond of being handled when they are rising in condition; and it is also serviceable to familiarise them with man; as cattle, when they have been accustomed to be handled, will stand better, and show themselves more satisfactorily to the buyer. There is something so winning in a gentle disposition in powerful animals, caused by good treatment, that a buyer will prefer them, when they have to be driven a distance upon the road; and the butchers in the neighbourhood will also prefer them, as they will walk peaceably to the shambles, without the risk of being raised to a frenzy. All these constitute the minutiae of the business of feeding cattle on turnips in winter; and, trifling as they may appear, attention to them will be amply repaid, in the shape of prime beef and docile cattle. The whole may be easily accomplished by any man who regulates his movements by the watch; and the man who has the charge of cattle in winter that will do this, whether he is seen by his master or not, is an inestimable servant.

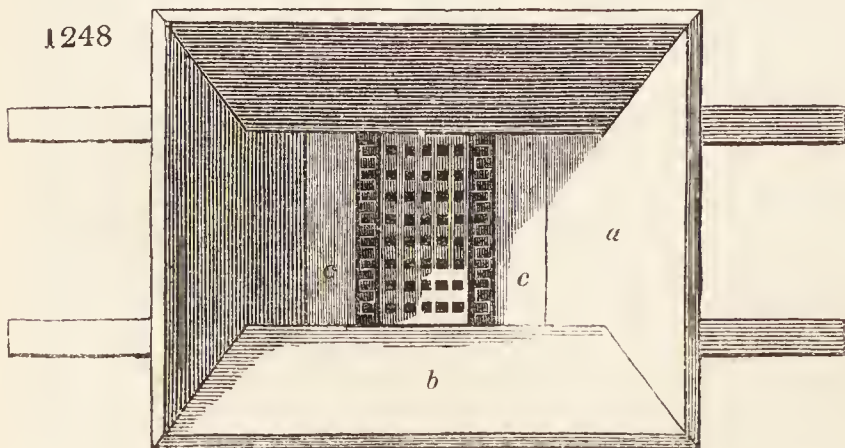
8440. *The quantity of turnips which feeding cattle will consume*, as stated by most writers, is about one ton every week, for an ox of from sixty to seventy stones, or about one acre of a fair crop of turnips in six months. Thirty-three double-horse cart-loads of turnips, each weighing from sixteen cwt. to eighteen cwt., are a good crop on light sharp lands.

8441. *Time of putting up to feed.* If the second growth of grass has continued fresh till the latter part of autumn, cattle may be soon enough put up to feed by the 1st of November; but if the grass fail sooner, which it will in most seasons do, the middle of October is late enough for putting them up to feed. White globe turnips are an excellent juicy food for cattle till the commencement of the new year, after which should follow the yellow or green tops, for two months longer, and then the Swedish turnips will finish the season. If the Swedish turnips have been stored up before the second growth of the stem has made its appearance in spring, they may be taken out quite fresh till the beginning of June. Since the cultivation of the potato has increased so rapidly, many people feed their cattle on it in spring, either wholly or mixed with turnips. When cattle are fed on potatoes, attention ought to be paid to them after feeding, for fear of internal swelling. When observed at first, the swelling may be allayed by pouring down the throat a bottleful or less of common whale oil, which will check the fermentation, and operate as a purgative. Should any of the young cattle or the feeding beasts in the byre be choked with a piece of turnip, for those fed in hammels never or very seldom do so, the best expedient is to use the probang at once, rather than to permit the throat of the poor animal to be squeezed and consequently inflamed in attempting to push the piece of turnip up and down. The probang may be used with great success, by causing the animal to be forcibly held by superior strength, with its neck and mouth stretched forward, and while one is pushing the instrument gently down, another is directing the end of it down the gullet on the outside of the neck. When the piece of turnip is pushed down into the stomach, let the instrument be gently drawn out; and if, during the operation, the animal forcibly twists its head about, the instrument should instantly be let go. Feeding cattle will eat very little straw; but they ought to have abundance of litter at all times.

8442. *Comparative merits of feeding cattle in hammels and byres.* "Our decided predilection is in favour of hammels. In them the cattle are at perfect liberty to roam about, if disposed for exercise: they are exposed to all the sunshine there may be in a winter day; and the very rain which falls on their backs titillates the skin, and causes them to lick and clean themselves; they are comfortably warm in their sheds among an abundance of straw in the coarsest night, and cattle will never suffer from cold, when they have a comfortable shelter to which they can repair at will; they can come and go to their food whenever they please, night and day, and, their meat being constantly in the open air, it will be always fresh and sweet; and their feet and hair, when they come to travel, are quite able to bear the hardness of the road and the coldness of the air. These are all advantages which no byre can confer. Nor are the hammels so expensive in their original erection as many represent them to be. We have seen a range of them consisting of five divisions, capable of feeding twenty large oxen, erected for 20*l.*; but these had no regular roof. The roofing of all buildings is the most expensive part of them. The roof of those to which we refer, consisted of trees laid across as beams, about a foot asunder, the space between them being filled up with the branches of the spruce fir and Scotch pine. Such a place was a choice one for stacking pease or beans upon. To this purpose it was often appropriated; or it was covered with straw, roped down, which was used as bedding for the cattle in the first part of the succeeding season, when fresh straw was put in its stead. In the hammels which faced the south, the cattle were well fed and comfortably lodged; and no byre could have afforded so much accommodation at the same expense." (*Quart. Jour. Agr.*, vol. ii. p. 241.)

8443. — 6978. *Milk is preserved from becoming acid* by the addition of any alkali; because, when milk ferments, it develops an acid, which the alkalies neutralise. Hence alkalies prevent the curdling of milk. Alkalies applied to curd will turn it into milk: they are not unwholesome, but in large quantities give the milk a disagreeable flavour. (*L'Agriculteur-Manufacturier*, Mai, 1831.)

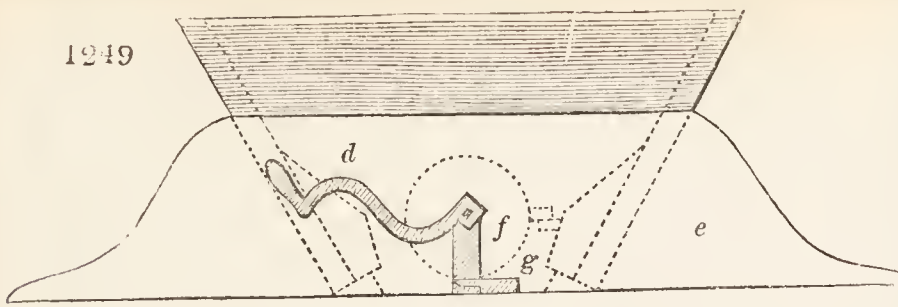
8444. — 7008. *A curd-breaker for skim-milk cheeses* (figs. 1248. and 1249.) has been invented by Mr. Robert Barlas, of Gilmour Place, Edinburgh. It consists of a hopper of wood (fig. 1248. *a*), seventeen inches and a half by fourteen inches on the top, and ten inches in depth; and a cylinder of hard wood six inches



and three quarters (*b*) in length, and three inches and a half in diameter. The cylinder is studded with square pegs made of hard wood, each a quarter of an inch in the side, cut square at the ends, and projecting three eighths of an inch. There are eight teeth in the length, and fifteen in the circumference, of the cylinder, 120 teeth in all. It revolves on a round iron axle twelve inches in length, and is moved by the crank handle (*d* in fig. 1249.); *c c* are two wedge-shaped pieces of hard wood, made to fill up, in some degree, the space between the side of the hopper and the cylinder. These pieces rest on a slip of wood nailed to the lower

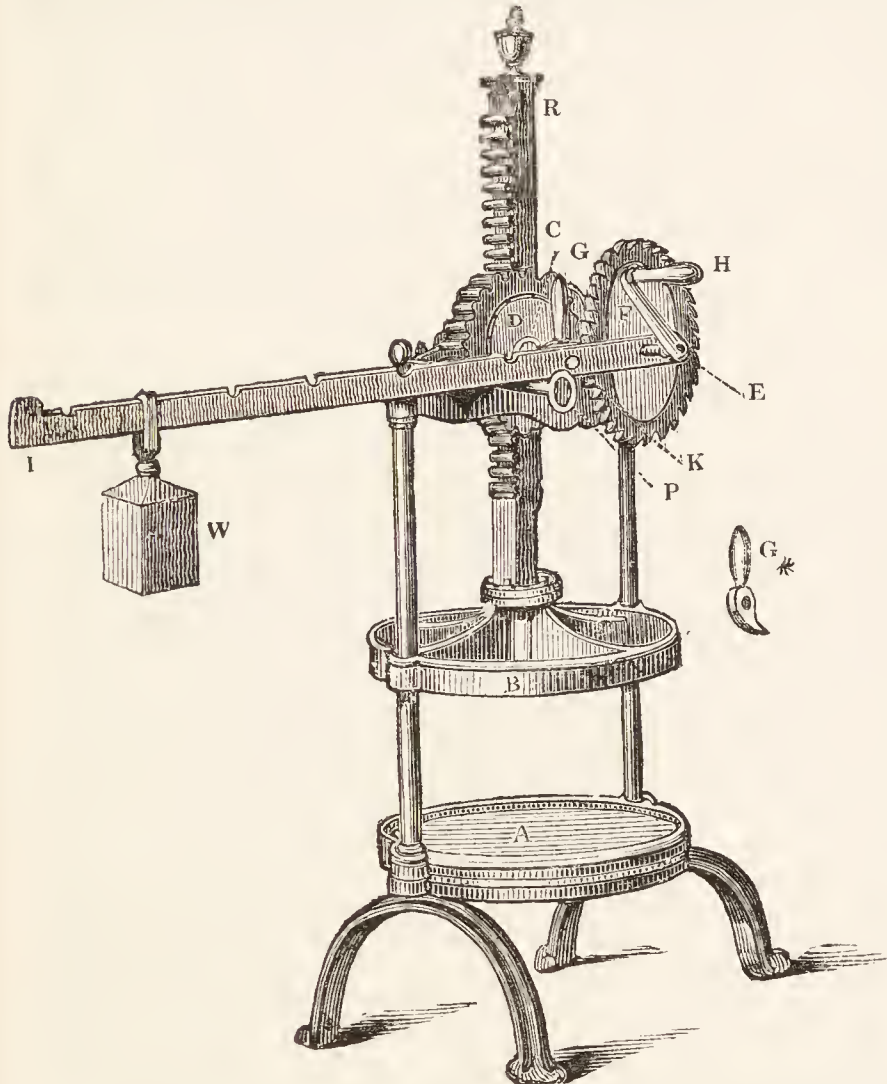
rim of the hopper, to keep them in their place. The face of these is studded with nine teeth of hard wood, similar to those on the cylinder, at opposite sides.

1249



The stand (e) (fig. 1249.) can be made of any length, to suit the breadth of the tub into which the curd is broken. The implement is used in this manner: — Place over it a tub, heap the hopper (a), with curd, and, on turning the winch (d) in either direction, the curd will fall, broken quite small, into the tub. While one hand is moving the machine, the other can press the curd gently down into the hopper. As cleanliness is a matter of the greatest importance in cheese-making, the internal parts of this machine, being loosely put together, can be easily taken to pieces to clean. The cylinder axle rests on two hard wooden blocks (f, fig. 1249.), one on each side, which slip out of their groove. They are held in their working position by the thumb-catch (g), sunk flush with the bottom of the stand (e), one over each block. The wedge-shaped pieces (c c, fig. 1248.) come out. To prevent the curd working out of the sides of the axle, the cylinder is set a little at both ends into the sides of the hopper. The dotted lines in fig. 1249. will give an idea how the internal part of the machine is constructed. Only one tooth is represented on the cylinder by the dotted lines, to show the position of the whole. (*Quart. Jour. Agr.*, vol. iv. p. 385.)

8445. Baird's cheese press (fig. 1250.) is one of the most convenient in use.



The form containing the curd is put on the bottom plate, A, and the top plate, B, is made to descend and press on it. There are two ways of doing this: one quick and easy, until the resistance becomes great; and the other slower, but more powerful, and used for the conclusion of the operation. On the axis, c, of the wheel, d, there is a pinion of eight teeth (not seen in the engraving) which works in the rack, r. On the axis, e, there is another pinion of eight teeth (concealed by the other parts) which acts in the wheel, d, of twenty-four teeth. This axis, e, may be turned by the winch handle, h, three turns of which will make the rack descend through a space corresponding to eight of its teeth. In this way the plate, B, may be lowered to touch the cheese, and to commence the pressure; but when the resistance becomes considerable, the second method of acting on the rack must be resorted to. On the axis, e, besides the pinion before-mentioned, there is a fixed ratchet wheel, f: the lever, i, forked at the end, which embraces f, is also placed on this axis, but turns freely round it. In the forked part of f, there is a pall or click, g (better seen at g*), which, turning on the pin, k, may be made to engage in the notches of the ratchet-wheel, f. By means of this arrangement, when i is raised up, and g

engaged in f, the axis, e, and its pinion, will be turned round with great power on depressing the end, i, of the lever; and by alternately raising and depressing i, any degree of pressure required may be given to the cheese; after which, if it be wished to continue the pressure, and to follow the gradual shrinking of the cheese, the lever is to be raised above the horizontal position, and the weight, w, hung on, which will cause it to descend as the cheese yields. By inserting the pin, k, this effect may be discontinued, and the farther descent of B prevented. (*Highland Soc. Trans.*, vol. x. p. 52.)

8446. The pneumatic cheese press (figs. 1251, 1252.) is the invention of John Robison, Esq., Sec. R.S.E. When of full size, this press may consist of a stand about three feet high, on the top of which may be fixed a tinned copper or zinc vessel, of any required capacity (say eighteen inches diameter, and eighteen inches deep), to contain the prepared curd. This vessel should have a loose bottom of ribbed work, covered with wirecloth, from under which a small tube, nearly twelve inches long, should communicate with a close vessel, capable of containing all the whey which may be drawn from the curd in the upper vessel. At one side of the stand there may be a small pump-barrel of about seven inches deep, from the bottom of which a suction pipe should terminate at its upper end in a valve opening upwards, and a piston, with a similar valve, should be placed in the pump-barrel, and be worked by a jointed lever, as shown in the model. The process is to be conducted as follows: — The curd being prepared, and salted in the usual way, a cloth is to be put over and into the upper vessel, and the curd put lightly into it, except round the edges, where it should be packed quite close to the sides of the vessel, so that no air may pass that way; the pump handle is then to be briskly worked for a few minutes, on which the pressure of the external air will force the whey to run down the tube into the whey-vessel; when it ceases to run, a few strokes of the pump may be repeated. The cloth and its contents are then to be lifted bodily out of the curd-vessel, and to be put into a mould of close wirework, with a weight placed over it until it become firm enough to be handled. The mould should stand on a sparred shelf (a shelf made of laths like a bacon rack) to allow the air free access to it on all sides of the cheeses. In fig. 1251, a is a vessel containing the curd; b, a vessel for containing the whey; c, a tube communicating from a to b; d, an air pump

for exhausting the air in *b*; *e*, tube communicating from *d* to *b*; *f*, a tub for letting off the whey from *b*

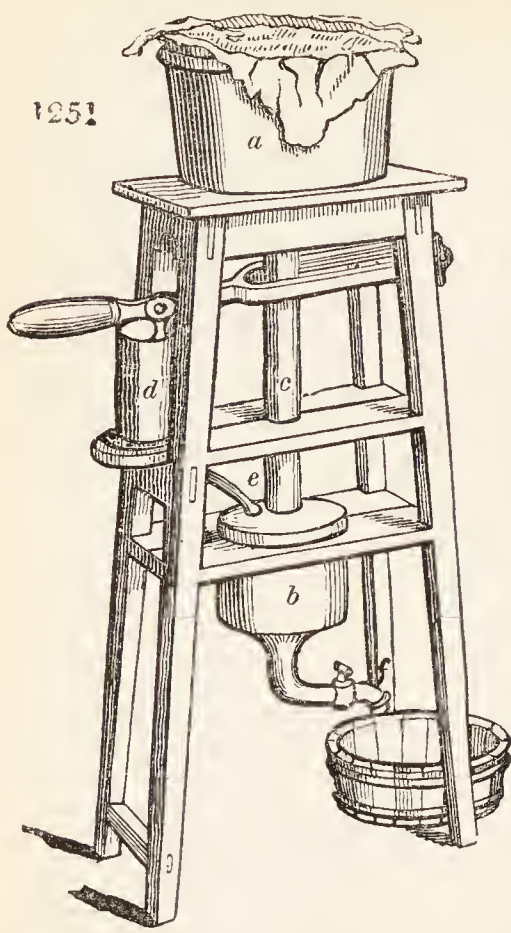


Fig. 1252. is a false bottom for the vessel *a*; *g*, wood frame; *h*, wirecloth. (*Highland Soc. Trans.*, vol. x. p. 200.)

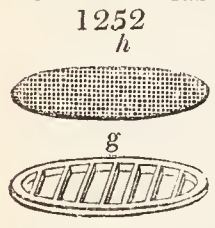
8447.—7086. *New Stilton cheeses* may be made to acquire the flavour and appearance of old ones, by inoculating them with portions of the old, containing blue mould. The little scoop which is used in taking samples of cheese, affords a ready means of performing the operation, by interchanging ten or a dozen of the rolls which it extracts, and placing them so as to disseminate the germ of the blue mould all over the cheese. A new Stilton cheese, treated in this way, and well covered up from the air for a few weeks, becomes thoroughly impregnated with the mould, and generally with a flavour hardly to be distinguished from the old one. (*Highland Soc. Trans.*, vol. xi. p. 233.)

8448.—7184. *Management of the fleece in Australia.* In order to assimilate the Australian wool as much as possible with the German, in preparing it for market, the fleeces should not be broken, but merely divested of the breech and stained locks, and so assorted or arranged that each package may contain fleeces of the same character as to colour, length of staple, fineness of hair, and general quality.

8449. *If the washing* has been performed at the same time and place, and with an equal degree of care, the colour is likely to be uniform, and it will then only be necessary to attend to the separation of the fleeces as to length, fineness, and general quality; but if a large grower has flocks of different breeds, and fed on different soils, care should be taken that the fleeces be separated, first, as to colour, and then, again, as to length, fineness, &c.

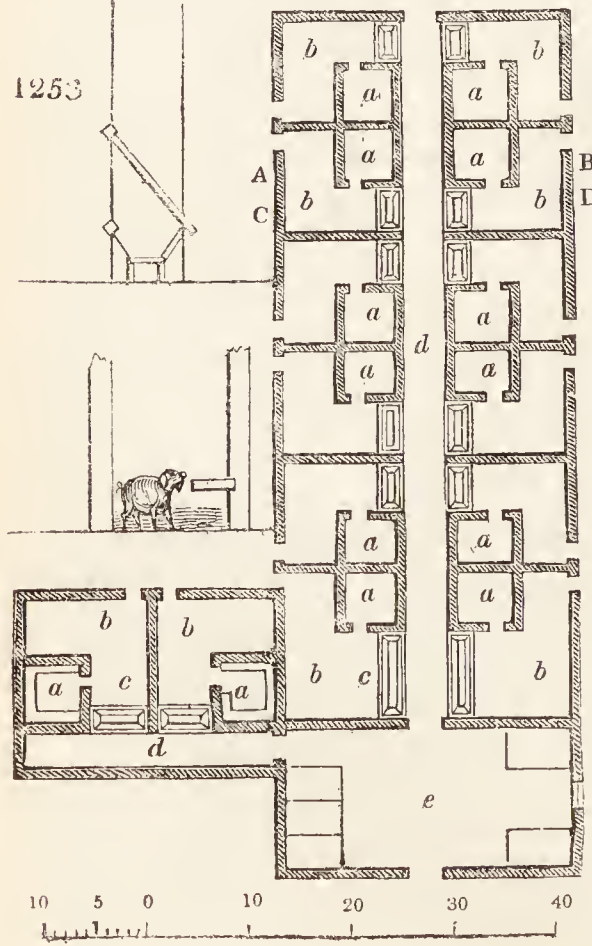
8450. *Packing.* The fleeces, being assorted as already suggested, should be spread one upon another, the neck of the second fleece being laid upon the tail of the first, and so on alternately to the extent of eight to ten fleeces, according to their size and weight. When so spread, the two sides should be folded towards the middle, then rolled together, beginning at each end, and meeting in the centre; and the roll or bundle, so formed, should be held together by a slight pack-thread.

8451. *The bagging* should be of a close, firm, and tough nature. The material hitherto most generally used has been sail canvass, which very ill resists bad weather on a long voyage, and, when received here, even in favourable condition, is so dry and crisp, that it will tear like paper. A thicker, twilled, more flexible, and tough material would be preferable. The size and form of the package may be in length about nine feet, and in width four feet, sewed up on the two long sides, and at one end; the other end being suspended with the open end upwards to receive the bundles made up as before directed, which are to be put in one at a time, one of the flat sides of the roll or bundle being put downwards, and so on in succession; and the whole being well trodden down, until sufficiently filled for the mouth to be closed. This is the German mode of packing, but it is doubtful whether packages of the dimensions that have been hitherto sent from the two colonies may not be more convenient for so long a voyage.



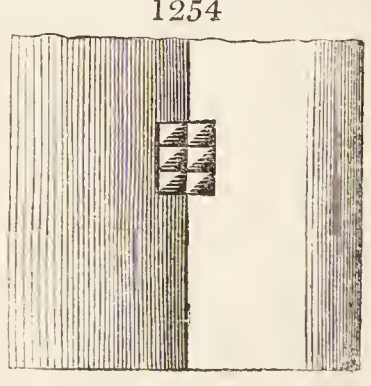
8452. *The operation of screwing* should be discontinued where it has been practised; as the pressure by the screw, and the remaining compressed during the voyage, occasions the wool to be caked and matted together in a manner that is highly prejudicial to its appearance on arrival. The practice, also,

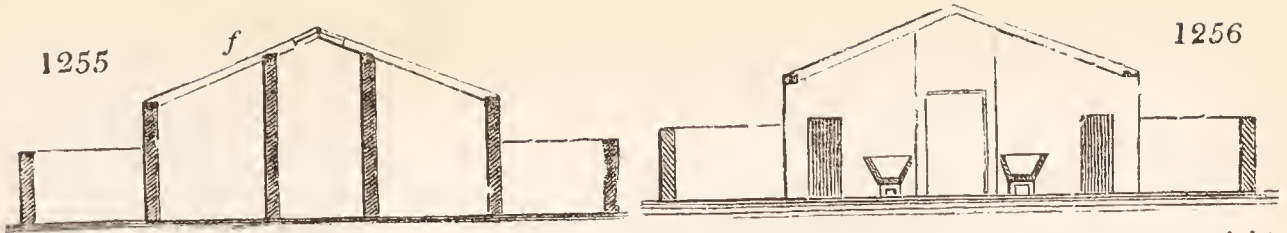
of winding up each fleece separately, and twisting a portion into a band, is productive, in a minor degree, of the same prejudicial effect; and it is to avoid this, that the making German bundles of eight or ten fleeces is suggested. (*Hobart Town Courier*, Jan. 8. 1834.)



8453.—7274. *A pigsty* is a building which a general observer is in the habit of thinking requires no great care either in the plan or in the execution; but the experienced agriculturist is of a very different opinion. Pigs, to thrive, must be kept dry, warm, and clean, and this they cannot be without some contrivance. In general, a pigsty consists of two parts, a small open yard, and a small covered house, or shed; in the former, the animal eats and takes exercise, and, in the latter, he keeps himself warm and sleeps. As an example of a complete range of pigsties erected at Bagshot Park Farm, by Mr. Burness (see *Gard. Mag.*, vol. x. p. 332.), we refer to fig. 1253., which is a ground plan of a very complete building for breeding and fattening pigs. In this figure, *a* represents the lodging-houses; *b*, the exercise courts; *c*, the troughs into which food is put; *d*, passages for supplying food; and *e*, a house containing the food, in which there is a boiling and steaming apparatus, and three large tanks, for fermenting the food before it is used.

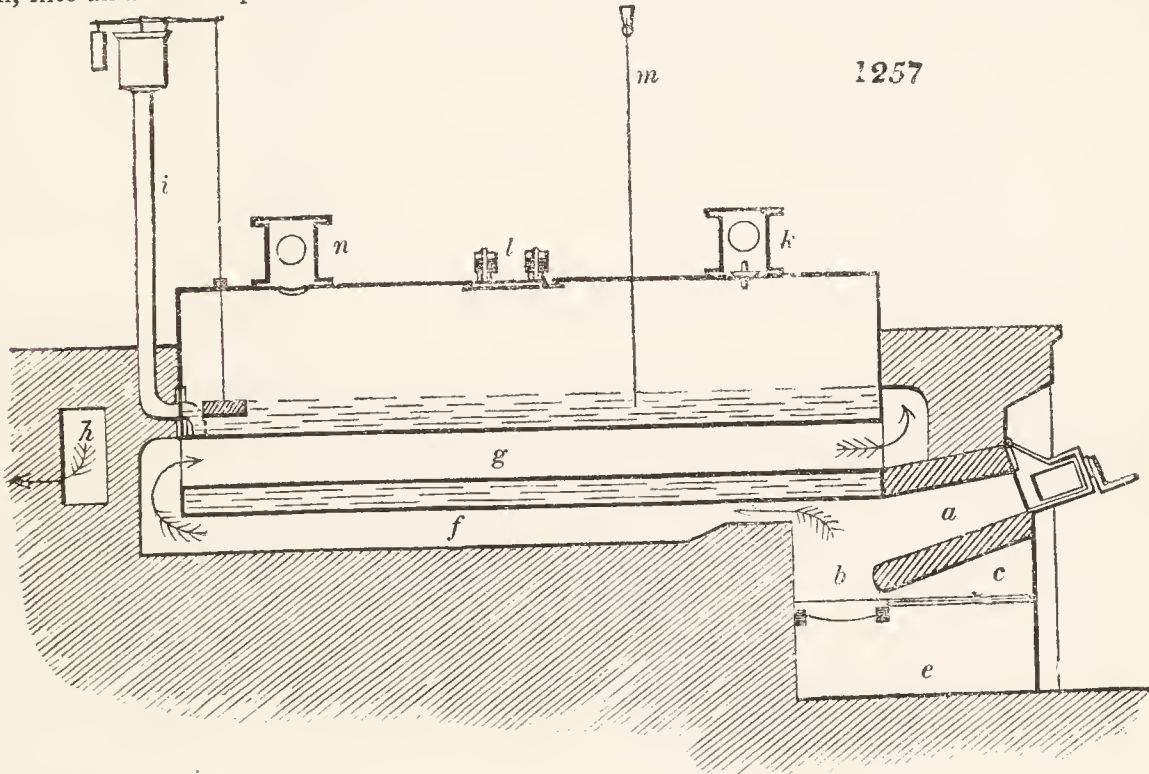
Fig. 1255. is a section, on a larger scale, on the line A B, and fig. 1254. is a vertical profile, on a still larger scale, of part of the roof, showing the cover of one of the ventilators, marked *f*, in fig. 1255. Fig. 1256. is a section, on the line c D, on the same scale as fig. 1255.





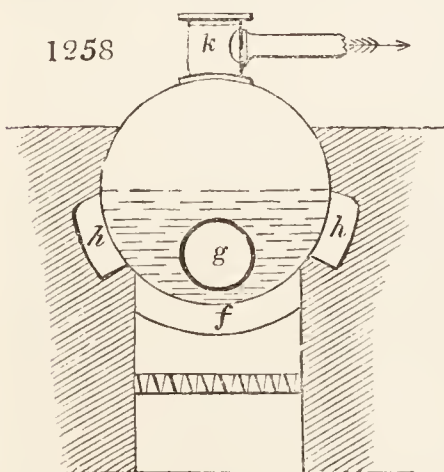
8454.—7315. *Preparation of food for swine.* Mr. Bolton, who has fattened swine to an enormous weight, has the following observations on the subject in the *British Farmer's Magazine*, vol. vii. We consider them worthy of quotation, with a view of impressing on the mind of the reader the importance of fermenting food for this class of animals:—"I always feed my pigs on sour food, which I have invariably found to feed them faster, and to make the flesh firmer and whiter, than food given in any other state. The following is my method of preparing it:—As soon as the potatoes are steamed, I have them, while quite hot, beaten to a pulp, and mixed with bran, in the proportion of twenty-eight pounds of bran to a sack (240 pounds) of potatoes, and this mixture is put into a vat for ten or twelve days, till quite sour; this food makes the pigs fat enough for porkers or small bacons. When I require them more than commonly fat, I begin with fifty pounds of barley flour, instead of the bran, to each sack of potatoes, gradually increasing the quantity of flour till it amounts to half the weight of the potatoes; when the quantity of flour is greater than the moisture of the potatoes will absorb, I add a sufficient quantity of water to make it into a thick paste: I never give it until it has fermented."

8455. *A description of Mallet's improved apparatus for cooking fodder for cattle by steam.* The simplest form of apparatus for this purpose usually met with, consists merely of a common open boiler, over which a tub, with its bottom perforated, is placed, and the junction rendered steam-tight by what is called a water-valve or water-lute joint; that is to say, by the lower edge of the tub projecting below its bottom, into an annular space round the upper edge of the boiler, filled with water. The tub is filled with



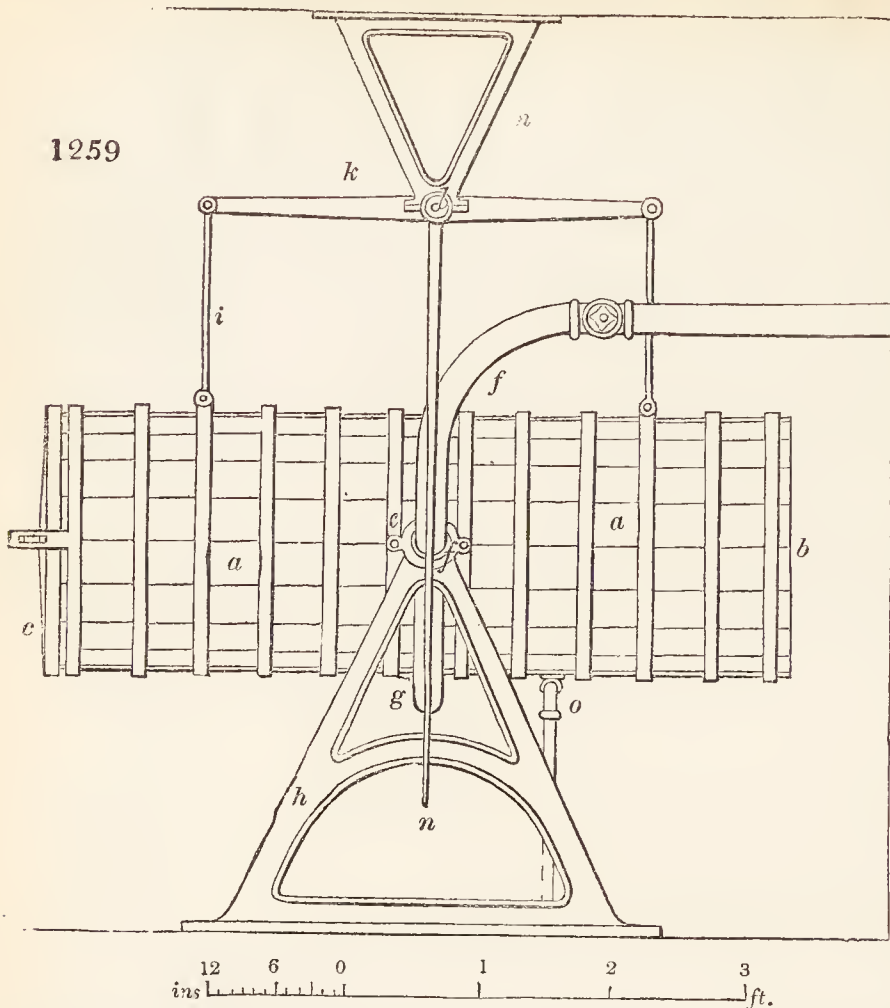
the vegetable matter to be cooked; and the steam rising through the perforations of its bottom, from the water beneath (a fire having been lighted under the boiler), prepares it. This apparatus, excellent as it appears from its simplicity, has many disadvantages. The tub requires to be lifted on and off, by means of a crane, if of large size; a separate boiler is required for each tub; there is no mode of regulating the supply of steam, but by damping the fire, or urging it; and the boiler, to be supplied with the water spent in steam, needs the tub to be previously lifted off. Added to all, the boiler must be circular, and, therefore, of the worst possible form for economy of fuel. The next form is that in which several steaming vessels are supplied from one boiler, which may be of any form. Each of these vessels consists of a tub, as before, with a perforated bottom, and close but movable cover, which is placed on another shallow tub, with a close bottom, into which the steam from the boiler is conducted by a pipe from the boiler; the junction between the two tubs being made good, either by three or four thicknesses of felt, or by a gasket; a cock regulates the admission of steam

the whole range, and lifts them on or off. The arrangement answers tolerably well, but has some inconveniences. But a comparatively small surface of the potatoes or other fodder is exposed to coction. The crane for lifting off the tubs, when each is capable of containing from four to six barrels of potatoes, requires to be a strong and rather costly piece of work; and the consumption of time and labour in lifting on and off, filling and emptying those tubs while hot, is very great, whereby a considerable loss in fuel accrues. All these considerations may be of small importance where the quantity of fodder cooked is small, and therefore the cost of labour and fuel slight; but where a large stock of cattle is to be fed with cooked food, and the apparatus is therefore nearly at constant work, every consideration of facility and economy becomes in the highest degree important. Accordingly, the following train of apparatus was designed for a gentleman, who is not only an extensive rearer of cattle, but one of the most distinguished agricultural improvers in Ireland.* It is conceived that it embodies most, if not all, that can be wished for the purpose. Fig. 1257. is a longitudinal section of the boiler, which is cylindrical, and four times its diameter in length. Witty's patent gas-furnace is applied to it



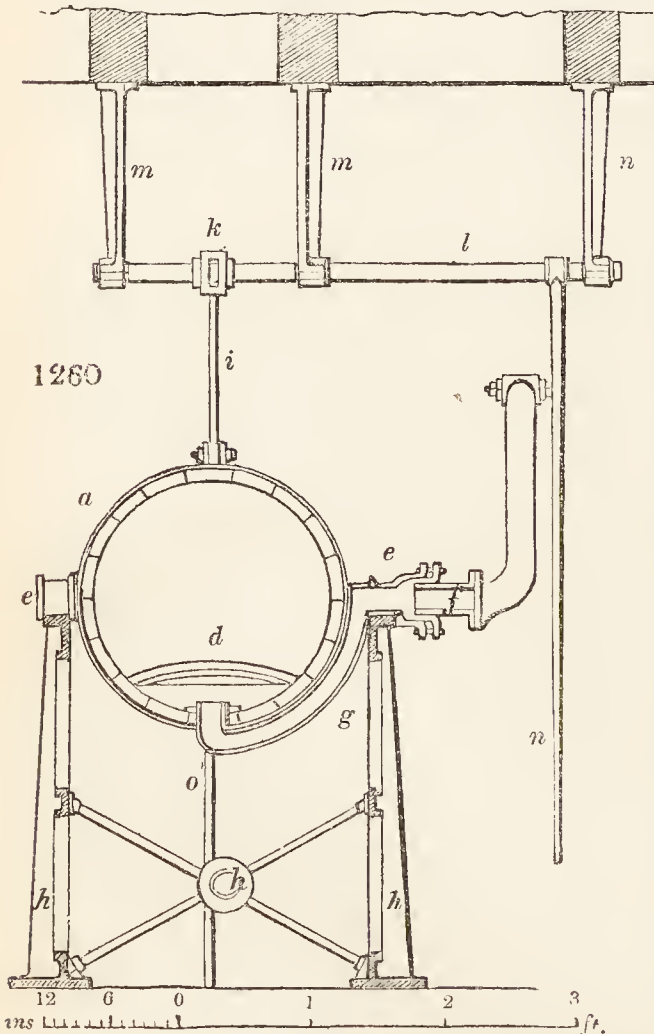
* Robert La Zouche, Esq., of Harriston.

a is the inclined plane; *b*, the fire bars; *c*, the dead plate; *e*, the ash-pit.



The flame and heated air passes under the boiler, through the bottom flue, *f*; thence through the tubular flue, *g*, right through the body of water in the boiler; at the extremity of which it goes off, right and left, through two lateral flues, which join at *h*, and go into the stack or chimney: *i* is the feed head, supplied either from any sufficiently elevated source, or by a pump; it is adjusted, to supply the boiler at a pressure of $1\frac{1}{2}$ lb to the square inch: *k* is the safety valve, loaded to the same pressure; the steam from it blows into the flue; *l* is the man-lid; *m*, a whistle, for the purpose of giving notice when there is a deficiency of water in the boiler, should such ever take place; boilers upon this construction being much more liable to injury in this respect than those which have no internal flues: *n* is the steam-pipe and stop-valve, which is connected with the steaming vessels. *Fig. 1258.* is a cross section of the boiler: the same letters refer to both figures. The top part of the boiler, above the masonry, is covered with a wooden jacket, one inch thick, and supported by segments of angle iron, at an interval of one inch and a quarter from its external surface; and for the same reason the walls of its setting are all

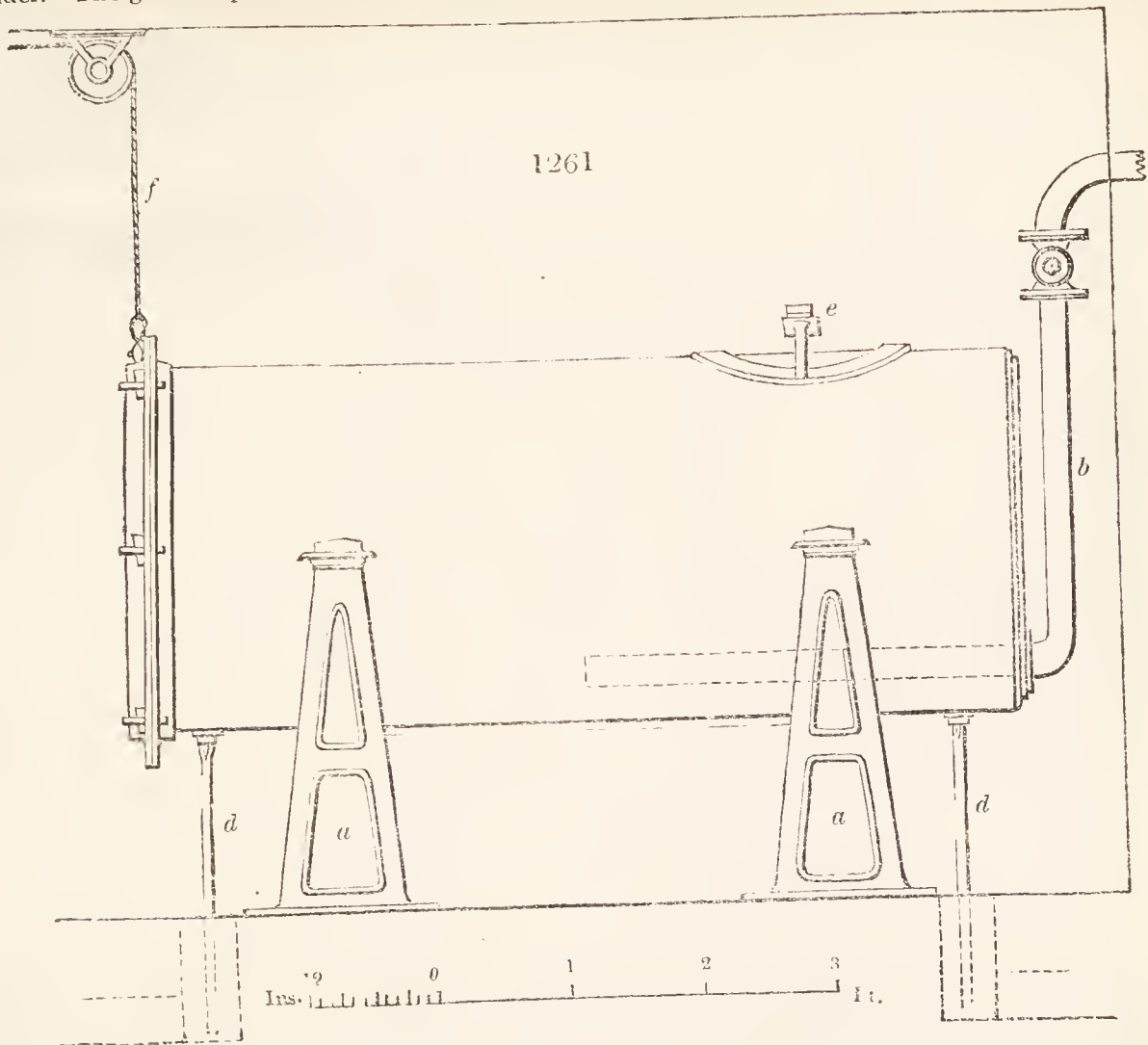
built hollow. *Fig. 1259.* is a side elevation of the steaming vessel for cooking potatoes, carrots, parsneps, turnips, &c., or other such things; of which *fig. 1260.* is a cross section, through the centre of its length; the same letters refer to both. *a* is the external cylinder or outer case of the vessel, formed of oaken staves, one inch and a half thick, hooped together, and having a close end, staved in at the end, *b*. The other end is closed by a movable lid (*c*) of wood, fastened by cotters driven through two links formed in projections from the adjacent hoop, and made steam-tight by a gasket, soaked in bees' wax and tallow;



it is capable of being very readily put on or taken off. In the lower segment of the cylinder, an arched wooden false bottom *d* is placed, stiffened by slight cross-ribs of cast iron, and perforated full of holes, five eighths of an inch in diameter; above, and supported by this, the matters to be cooked are placed until they quite fill the cylinder. The whole thing is hung upon two gudgeons or journals, *e e*, passing through the centre of gravity of the cylinder, when loaded; so that, by the arrangement about to be described, either end of it may be elevated or depressed. One of these journals is hollow, and immediately connected with the steam-pipe from the boiler by a stuffing-box, *f*; so that the steam enters the bottom of the cylinder through this journal and the curved pipe, *g*, the former having still free liberty of motion. Both journals move in brasses, resting on strong diagonal framing, *h h*, bolted down to a mass of masonry. *ii* are two wrought-iron links, connected by joints with the hoops of the cylinder at top, and with the extremities of the equibrachial lever, *k*; the centre of which consists of a Y shaft, *l*, supported by two or three slight frames, *m m m*, and having the long vertical lever, *n*, keyed on it at one end. These frames are bolted to proper timbers in the floor of the loft above. Now it is obvious that, by means of the vertical lever, *n*, either end of the cylinder may be elevated or depressed, and that the natural tendency of the whole system, when at rest, will be to remain horizontal. From the bottom or side of the cylinder at *o* proceeds a small tube, to take away the condensed steam; so made, that it shall permit the water to pass, and yet be steam-tight; and also that it shall remain vertical, whatever be the position of the cylinder. This is shown enlarged in *fig. 1264.* The upper end of the tube works in a steam-tight joint, *a*, like the pin of a common cock; but made so that there is a free passage through in all positions of the tube: the screw tail of this joint is secured into the bottom of the cylinder by a brass nut and felt washer; the joint

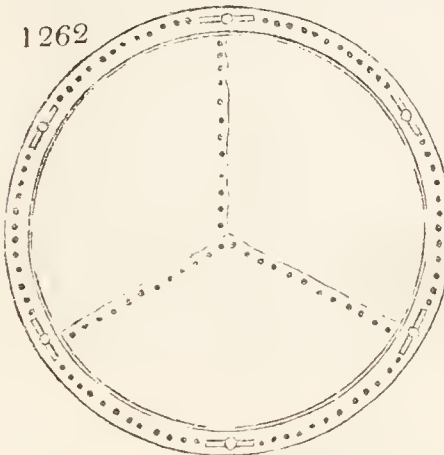
being placed with its axis of motion at right angles to the axis of the cylinder. The lower end of the tube, *b* (shown only in part), consists of an inverted siphon, the returning limb of which is of such a

length that the column of water retained in it is equal in pressure to the density of the steam in the cylinder. The greatest part of this tube hangs freely in a square aperture, below the level of the floors



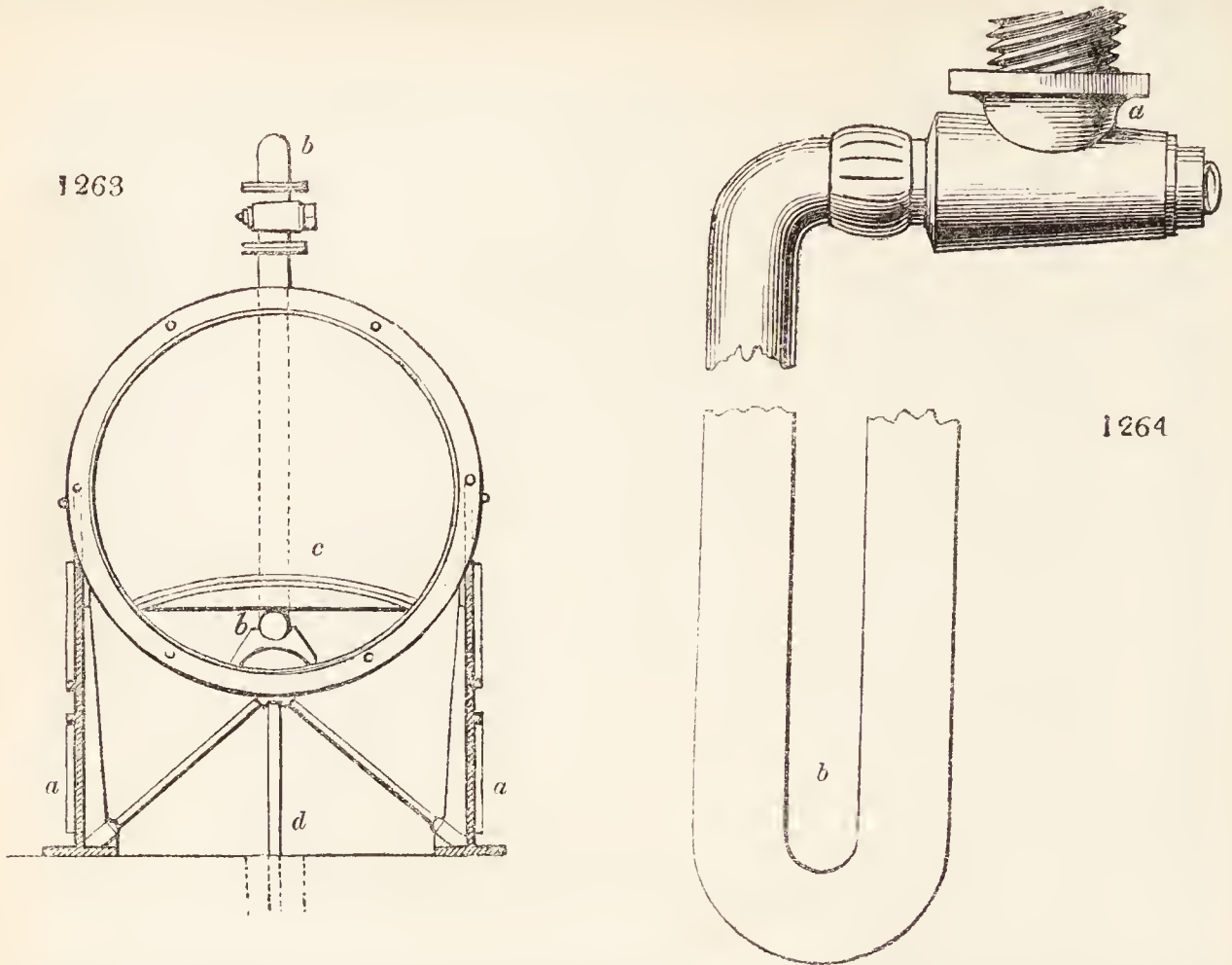
in *figs.* 1258. and 1259., where it is connected with a small sewer to take away the water. It is evident that, when the cylinder is moved, the tube will rise and fall vertically in the hole or upright trunk in the floor. Now for the mode of working this steaming vessel. The steam being up in the boiler, and the lid, *c*, removed, the end, *c*, of the cylinder is elevated to an angle of about 40°, when it comes just under a large wooden shoot or hopper from the loft above, close to which is placed a slicing machine, for dividing mangold wurtzel, turnips, or other large roots requiring to be steamed; from whence they drop direct through the hopper, or from sacks from men's shoulders, into the cylinder. When the situation permit of it) through the hopper, or from sacks from men's shoulders, into the cylinder. When it is full, the lid, *c*, is put on, and cotted tight; the cylinder again placed horizontally, and the steam admitted. When the steaming is complete, a low capacious truck, or a large square basket on wheels, or any other convenient receptacle, is brought under the end, *c*; the lid is removed, and the end, *c*, is now depressed sufficiently to cause the vegetable matter to fall out; the steam

being previously shut off: the operation is then complete. The false bottom is now to be withdrawn; and it, together with the inside of the vessel, scraped and washed: the former is only necessary when potatoes are cooked in it. The objects proposed in this arrangement are, perfect ease in filling and emptying, without the necessity of handling either the heated vessel or food; nearly a maximum capacity with a minimum cooling surface to the vessel; perfect staunchness, durability, and readiness of examination and cleansing of the interior. If there be no other elevated supply of water to the steam kitchen, a pump should be fixed in it, both to supply the boiler and to wash the vessels: potatoes, especially, leave a kind of slime upon the inside of steam tubs, which soon putrefies. It is said the cattle are sometimes choked by small potatoes, which are not sufficiently steamed; this might be prevented by the addition of a pair of rollers, into the hopper of which the cylinder might discharge its contents; and they would bruise all to a given size, and deliver into the truck before mentioned. *Fig.* 1261. is a side elevation of the cylindrical vessel for steaming hay, chaff, bran, oats, clover, &c. It is of a much



larger size than the cylinder for steaming more solid matters; and, therefore, is not made of wooden staves, but of iron plate riveted together like a steam boiler. *Fig.* 1263. is a cross section of the same: the letters of reference apply to both figures alike. The cylinder is supported on four vertical frames of cast iron, *a a*, properly connected by diagonal stays; one end of it is riveted in, and through it the steam-pipe, *b*, enters. The other end is movable, and closed by a circular lid or cover, also of boiler plate, secured by six cotter bolts, as shown in elevation, *fig.* 1261.; it is strengthened round its edge by a ring of two inches and a half angle iron riveted on, and is externally slightly convex: *c* is the convex false bottom, formed of sheet iron one eighth of an inch thick, punched full of round holes three tenths of an inch diameter, and stiffened by ribs of T iron, riveted to its lower side: *d d* are two siphon tubes for emission of condensed water, as before described: *e* is a man-lid for the purpose of filling in chaff, &c., or other such matters. The large end lid has got a counterbalance weight attached to the chain, *f*. The whole of this cylinder, and all the steam-pipes, are lapped over with thick felt or slight haybands, which are lapped over with thick felt or dreadnought; and this, lastly, is sewed tightly over with strong sail canvass painted. This mode of uniting, as a coating, several bad conductors having different conducting powers, is found to resist the passage of heat much more effectually than an equal thickness, of even the worst conductor of the three. This fact, which, I believe, has not been hitherto noticed, will at once suggest to the scientific reader some curious

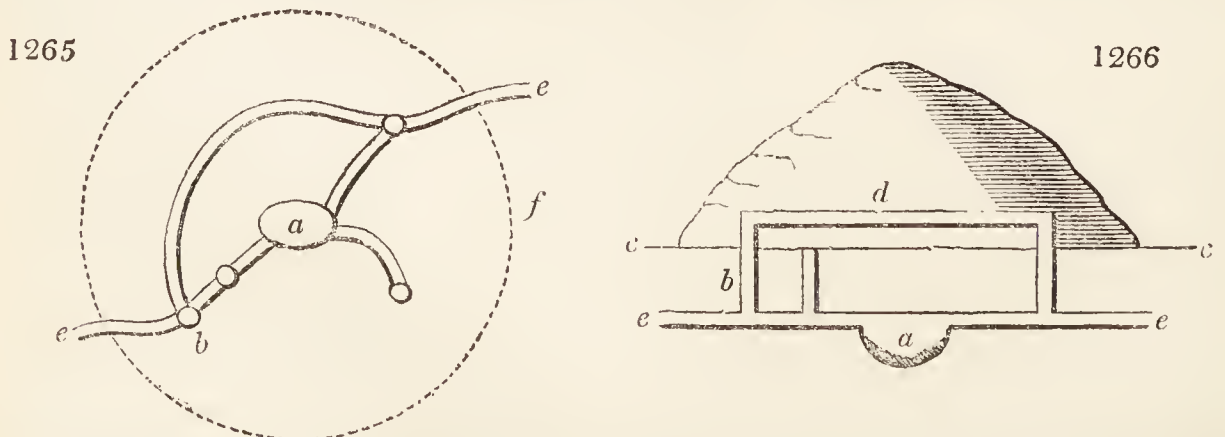
analogies to the passage of sound through media of different density; and which, indeed, caused the arrangement which has been described to be adopted. It will thus be seen that this second cylinder is



very similar in its general construction to that first described, except that it is not movable; which, from its magnitude, would be inconvenient, and is unnecessary for either hay or chaff, &c. Now of the mode of working it. In the loft above, immediately over the man-lid, *e*, is placed a chaff-cutter, and also a bean and oat bruiser, which both discharge by separate hoppers into the cylinder. The end lid having been put on and cotted up steam-tight, the vessel is thus filled with the desired material, which is spread uniformly with a fork through the man-lid. Steam is then turned on; and, when the operation is complete, the end lid is loosed and thrown up by the aid of the counterbalance above the cylinder end, and the contents drawn out by forks, or by a large but light and slender instrument like the worm of the ramrod of a gun. Before being used the first time, the inside of this vessel is given a coat of drying oil, and copal varnish mixed, which prevents subsequent oxidation. The general intent of the whole of the apparatus is to save labour and fuel, which it does effectually; and that portion of it for cooking potatoes is now about being erected in the new gaol of Mayo, the largest in Ireland. In some few cases, where the extent of the apparatus would be very great, and labour dear, it might be advisable to connect a small steam-engine with it, working from the same boiler, to pump water, slice turnips and mangold wurtzel, cut chaff, and bruise oats and beans, &c. Where a high pressure steam-engine pre-exists on a farmery for other purposes, the waste steam from it may be made fully available for steam-cooking apparatus, which thus would cost nothing; it requires, however, a particular adaptation, in order that the power of the engine may not be reduced, by driving the steam through any considerable resistance. Occasionally, but rarely, fluids may require to be boiled by steam, as stirabout for pigs, or wash for calves; for these, another form and construction of vessel altogether is necessary. (*R. Mallet.*)

8456. — 7431. *Warmth* is strongly recommended for promoting the health of poultry. Cold, it is found, either produces inflammation of the lungs, or pulmonary consumption. Heat constantly prevents this, and alleviates the disease when it has taken place. (*Annales des Sciences Naturelles*, as quoted in *Quart. Jour. of Agr.*, vol. ii. p. 568.) Warmth, also, makes fowls lay. Every housewife knows that eggs are most abundant in warm weather; and all country housewives know that the only way to make hens lay in cold weather, when eggs are dear, is to feed them well and keep them warm — the latter being of very nearly as much importance as the former. Some excellent observations on the subject of rearing and feeding poultry will be found in our *Ency. of Cott. Arch.*, § 1325, to § 1329., and § 1356.

8457. — 7631. *The mole* may be extirpated without the use of traps by digging up the mole hills in the course of the month of March, which is the breeding season. In order to give an idea where the mole's nest is to be found, reference may be had to *figs.* 1265. and 1266.; the first of which is an underground plan,

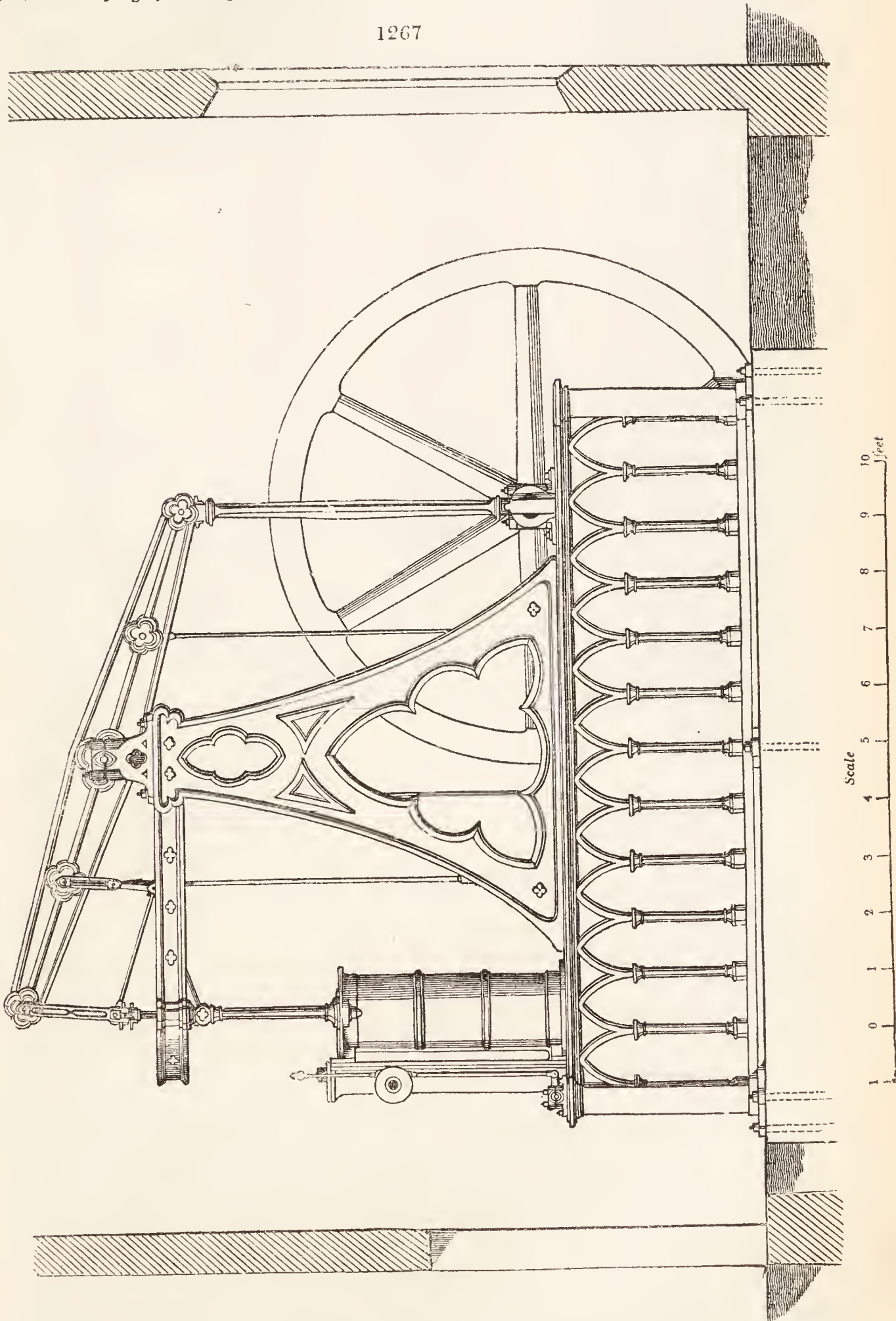


or horizontal section of a mole-hill, and the second a vertical section. In both these figures, *a* is the mole's nest; *b*, vertical tubes or runs, by which the mole ascends with the soil which it has excavated

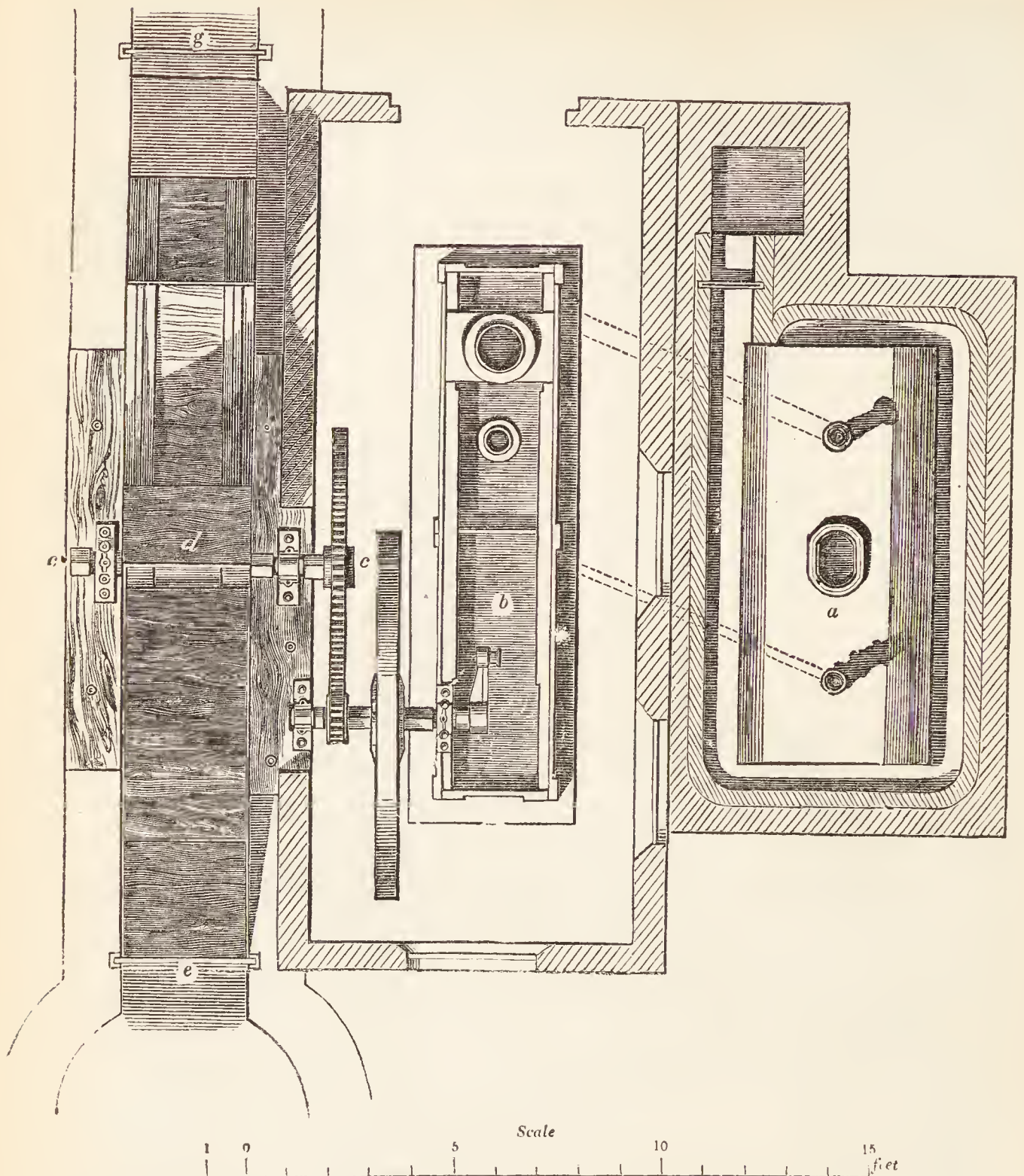
from the place forming the nest, in order to raise a hill over it to protect it from the rain; *c c* show the surface of the ground; *d*, a tunnel above the surface of the ground, in the soil of the artificial hill; *e e*, the common run of the mole extended to an unascertained length on every side; *f*, line indicating the base of the hillock. After removing the hill, and destroying the young moles, by waiting a little without making the least noise, the parent will make her appearance, and may be also destroyed. (*L'Agro-nome*, vol. i. p. 220.)

8458. — 7632. *A mode of catching rats* by baiting the traps with ground pale malt scented with the oil of caraway seeds, and which is said to be very effective, will be found described, at great length, in the *Quart. Jour. of Agr.*, vol. ii. p. 319. to p. 331.

1267



8459. — 7643. *Insects injurious to agriculture.* The following has been received from the writer of this article in the body of the *Encyclopædia*, W. Swainson, Esq. F.R.S. &c. — "Dear Sir, Although little disposed to notice the small critics, who love nothing so much as to be thought worthy of a reply, it is due to yourself that I should say something upon an attack made on the chapter regarding insects, written by myself in your *Encyclopædia of Agriculture*, and which attack I have just seen in an agricultural book,



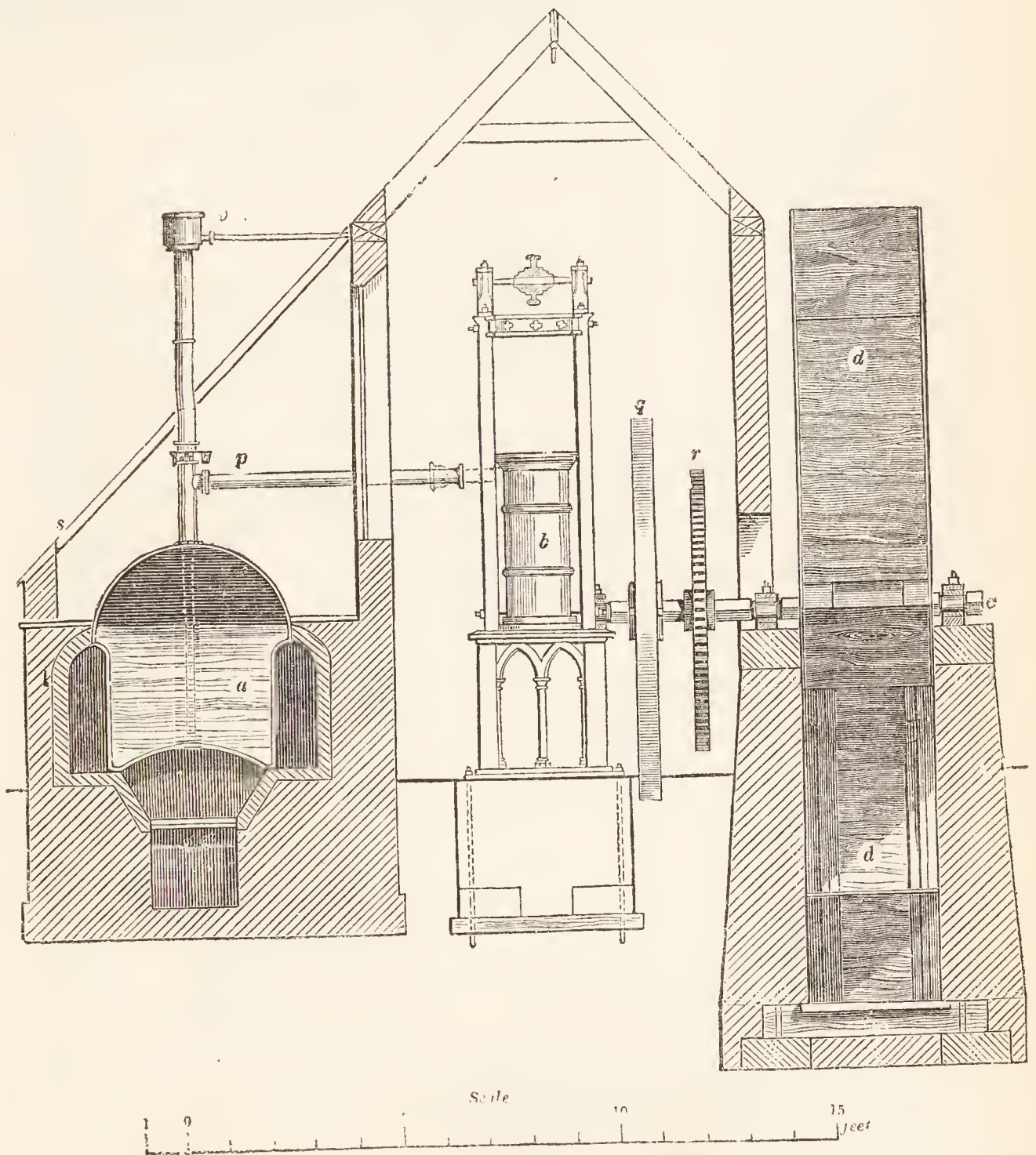
written in imitation of your excellent and useful work. It seems that I have said (p. 1113.), that, as the perfect suctorial insects (the *Haustellata* of *Clairville*) 'are supported by suction alone, it is obvious that in this state they can do no injury to the agriculturist.' Yet, says the critic, 'in absolute forgetfulness of this extraordinary assertion, Mr. Swainson, in the very next pages, tells us of the extensively destructive ravages of these very suctorial insects, which he has just before pronounced to be incapable of doing any injury to the agriculturist.' So far for the charge: now for the inference. 'Such palpable blunders as these require no comment, but I (the critic) cannot help remarking that they are calculated to lead to extensive practical inconvenience, to puzzle the agricultural reader most inextricably, and to destroy very much his confidence in all book instructors.' Literary blunders are of two kinds. They either originate in the ignorance of the author with regard to the subject he is writing upon, or in the haste of composition; in which latter case they are usually, if not always, discovered on perusing the proof sheet. If, however, by any chance, the proof is not seen (and I have no recollection of this circumstance), and the mistake is a 'palpable blunder,' it corrects itself; every one palpably perceives that it is an oversight, originating from the printer's omitting, perhaps, one or two words. It requires, indeed, no comment; for every one capable of reasoning sees at once that, by expatiating on the injury caused by the *Aphides*, I virtually correct the previous omission of those insects being an exception. So much for the 'palpable blunders,' the 'inextricable puzzlement,' the 'extensive practical inconvenience,' and the 'destruction of the confidence' of the agriculturist, the printer's omission has occasioned. 'The figures, indeed,' continues the critic, 'drawn by Mr. Swainson, prove his great accuracy as an artist; but the text equally proves that he knows little of insects beyond the atmosphere of cabinets and books, and that even his book knowledge is sadly deficient.' Now the figures in question were not drawn by me, but by Mr. Sowerby; and, in regard to the rest, who cannot help laughing at one of the oldest entomologists of England, who has, moreover, for years, lived under the temperate and tropical 'atmospheres' of both hemispheres, being gravely told that he knows nothing about insects beyond the precincts of his study! But when the same writer talks to us of the 'gross inaccuracy' of *LINNÆUS*, the 'credulous absurdity,' and the 'wild, mischievous, and absurd analogies' of *CUVIER*, the 'trash' of *MOHS* and *HÄIDINGER*, the 'absurdity' of *SAVIGNY*, and (to crown all) the 'flimsy productions' of *MACLEAY* and *HORSFIELD* (see the *Phil. Magazine*, Nov. 1831. No. lix.)*, need I add, that, to be associated in such a list (comprising, as it does, the

* The reader who wishes to know the entomological proficiencies of Mr. Rennie, will be greatly amused by turning to the *Entom. Journal*, vol. i.; and to the *Philosoph. Magazine*, for Nov. 1831. p. 372.

princes of science) will always be considered the greatest honour that can be conferred upon, dear sir, yours most truly — *W. S. Tittenhanger Green, Feb. 12. 1834.*”

8460. — 7776. *The agriculture of the different counties* in England, Wales, and Scotland, more particularly the grazing districts, will be found treated of in a work entitled, *The present State of the Tenancy of Land in the Highland and Grazing Districts of Great Britain*, by L. Kennedy and T. B. Grainger, published in 1829. This work contains a good deal of information on the subjects of sheep and wool, the great object of which is to show the difficulties under which the landowners and farmers are placed, in consequence of excessive taxation, as compared with the German baron who cultivates his own estate, or the agriculturist of Australia who possesses for nothing the right of pasturage over thousands of acres. The result of the whole is the “necessity of a protecting duty to the wool-growers.” The time for protecting one part of capital and labour against another is, we trust, rapidly passing away.

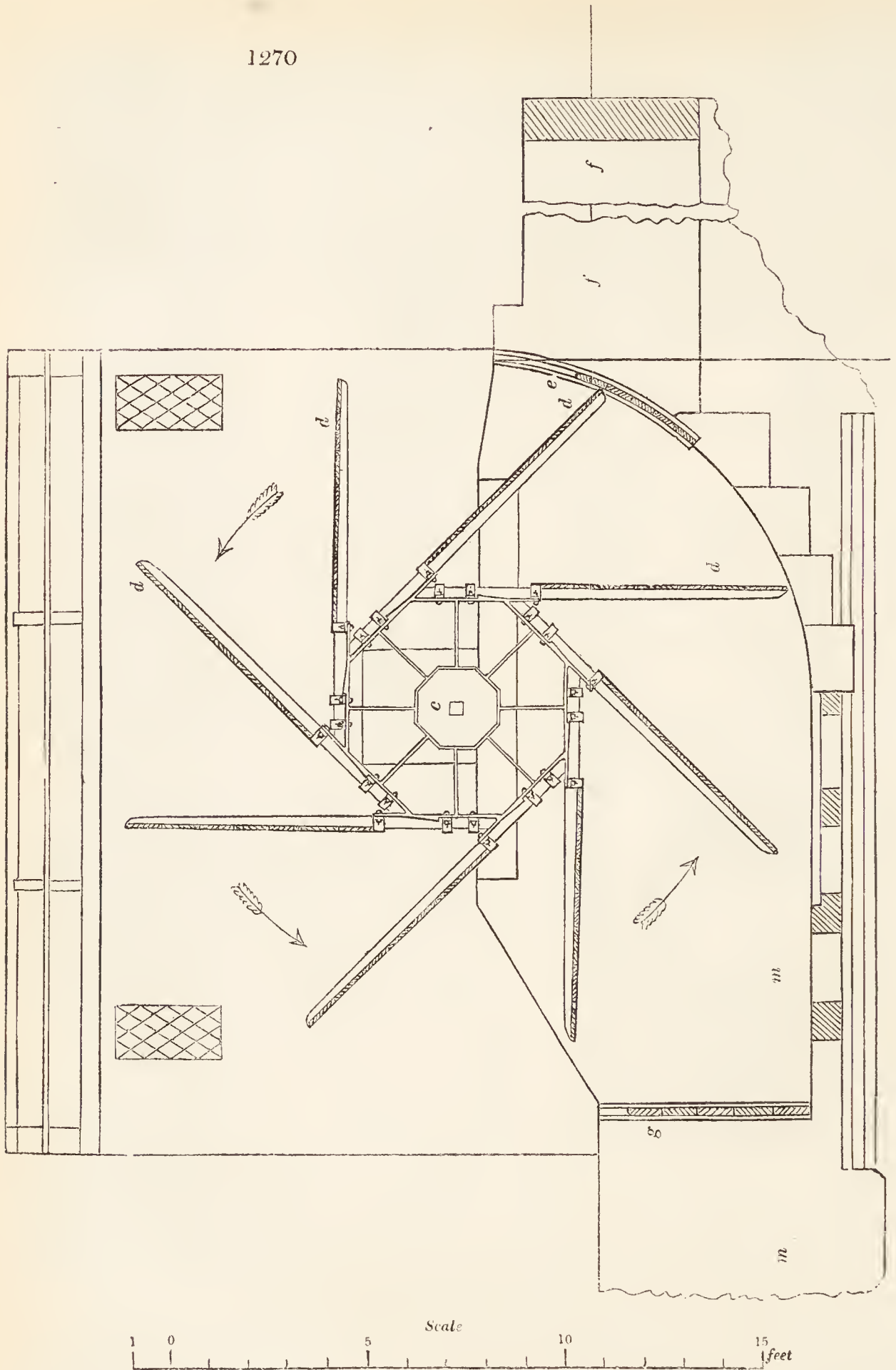
8461. — 7784. 11. *The application of steam to machinery for raising the water from fen and low lands.* We have mentioned (§ 7786.), that steam had been employed for this purpose in Cambridgeshire; and we have since learned from the account of a trial, in the newspapers (see *Times* for July, 1834), that a gas engine has also been so employed in the Cambridge fens. We are now enabled, through the kindness of Mr C. H. Capper, engine-maker, Union Foundry, Birmingham, to figure and describe a steam-engine and



lifting machine of a very superior description, which that gentleman has erected on the estate of — Drake, Esq., at Stainfield in Lincolnshire. “The great advantage,” Mr. Capper observes, “of bringing fen and low lands (formerly rendered useless by floods) into cultivation, by a small outlay of capital, must be my apology for troubling you with so minute a description of the draining machine I have erected for that purpose; and, as the same may be of use to a few, I shall feel obliged if you will give it a place in your work; and at the same time add, that by the great improvements which the use of locomotive carriages has made in high-pressure engines, I am enabled to say that as effective an engine as the one described might now be completed for a much less amount; or, if the landowners whose lands are subject to floods were to subscribe, a movable draining-machine might be made, at a very small expense.”

Fig. 1267. shows the elevation of a six-horse portable condensing steam-engine, working a second shaft, marked c, in figs. 1268, 1269, and 1270. On this shaft, the large water-wheel d d is fixed. This wheel revolves in a brick or stone casing, similar to that formed for the wheel of a common water mill, but so accurately fitted as not to allow of any water passing by either of the sides of the paddles, or by the front; because this wheel acts by its paddles lifting the water from the bottom of the wheel race up against the breastwork, and then throwing it over the sluice e. This sluice is formed of movable boards, to admit of regulating the lift of water at pleasure, from 3 feet to 8 feet in height. The water, being raised and thrown over the sluice e, falls into the pond or receiver f, whence it is carried off at as high a level as it

1270



will run ; in this case, at about 3 feet higher than the surface of the lands to be drained, and about 6 feet higher than the bottom of the drains. At the lower end of the trough there is a sluice, *g*, for regulating the quantity of water introduced into the lifting wheel ; because, if this were too great, the power of the steam-engine might be insufficient to turn the wheel, or the machinery might be injured. The wheel, as it will be seen, consists of eight iron paddles, fixed to an octagon iron casing ; each paddle acts by lifting up a portion of water from the bottom of the wheel-race, and raising it to the top of the sluice *e*. When the whole of the water, or nearly so, is lifted up, of course the boards composing the sluice *e* must be attended to, lest the water force its way back again upon the wheel.

Fig. 1268. is a ground plan of the boiler, engine, and water-wheel ; in which *a* is the boiler ; *b*, the engine ; *c*, the water-wheel shaft ; *d*, the paddles of the water-wheel ; *e*, the upper sluice, over which the water is thrown ; *f*, the pond or reservoir which receives the water ; and *g*, the lower sluice, placed across the drain which conveys the water to the wheel-race.

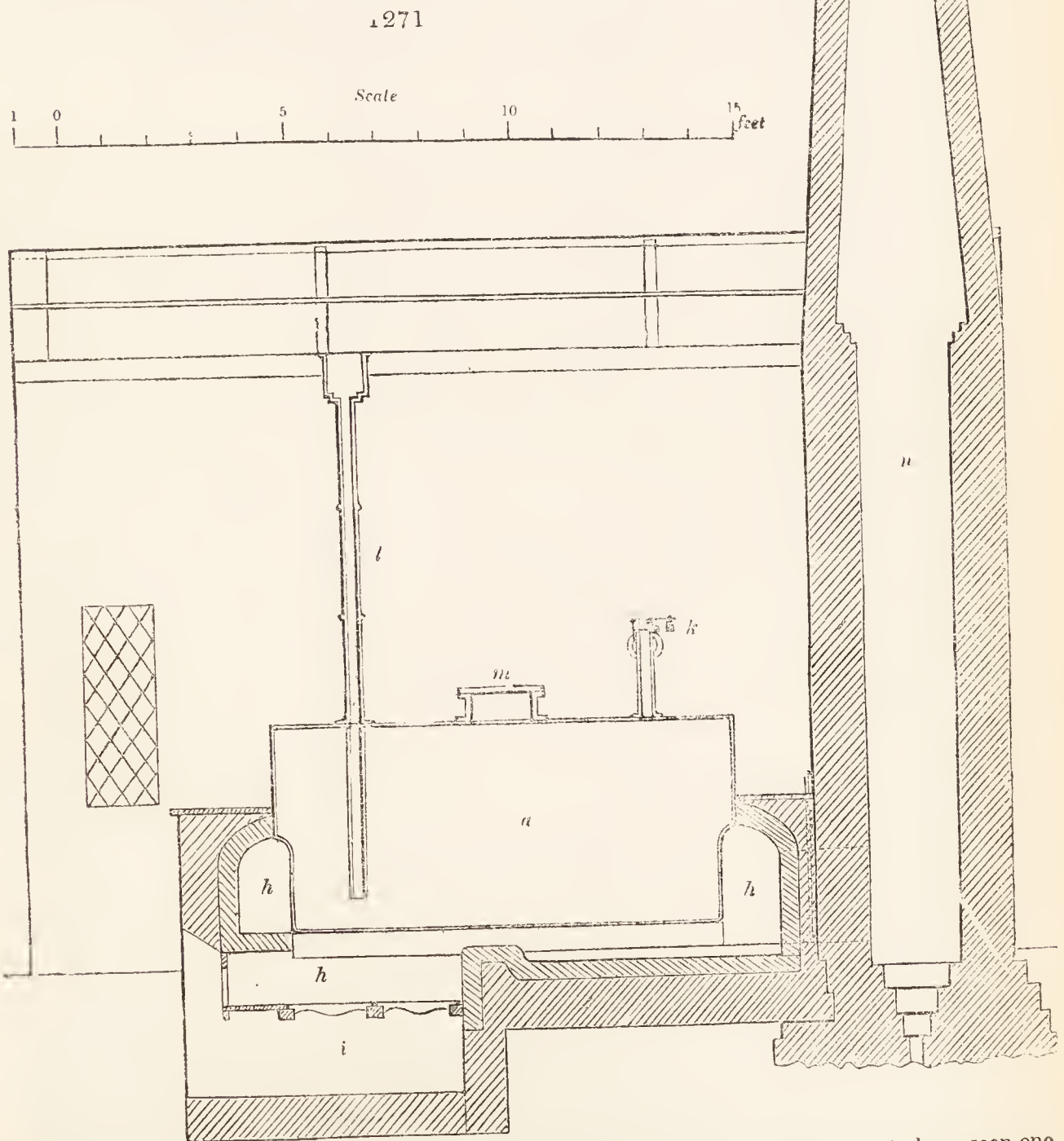
Fig. 1269. is a section through the steam-engine and the water-wheel ; in which *a* is the boiler ; *b*, the engine ; *c*, the shaft or axle of the water-wheel ; *d*, the paddles ; *e*, the tube for supplying water to the boiler ; *p*, the steam pipe ; *q*, the fly-wheel ; *r*, the spur-wheels ; and *s s*, the roof.

Fig. 1270. is a longitudinal section through the water-wheel, the trough, and the two sluices; in which *c* is the axle of the water-wheel; *d*, the paddles; *e*, the upper sluice, over which the water is thrown; *f*, the pond or reservoir to receive the water before it is carried off to the nearest river; and, *g*, the sluice to regulate the admission of the water from the land to be drained.

Fig. 1271. is a section through the boiler lengthwise; in which *a* is the boiler; *b*, the fireplace, and flue round the boiler; *c*, the ash-pit; *d*, the safety valve; *e*, the tube for supplying water to the boiler, *m*, manhole for cleaning out the boiler; and, *n*, the chimney.

8462. *Action of the machine.* After these particulars, little description will be needed; for it must be evident that, when the engine is set in motion, it will, by means of the wheel and pinion *r*, turn the water-wheel, *d d*, about its centre, *e*; and that, when set in motion, each of the arms will lift a quantity of water from the trough, or wheel-race, *m*, over the sluice *e* (see *fig.* 1270.), at a higher level to the pond or reservoir, *f*, whence it may be taken away as circumstances may require.

8463. *The expense of the portable steam-engine, exclusive of carriage, and putting up, was about 280*l.*; that of the fitting wheel, exclusive of the masonry, about 70*l.*; and the total expense of the whole about 450*l.**



8464.—7788. *Buildings. Mr. Coke's farm-houses.* Much as they vary in appearance, to have seen one of Mr. Coke's farm-houses is to have seen all, as respects character. Of these, besides such as have undergone repairs and additions, not directed solely to the acquisition of perfect comfort, but of highly tasteful ornament, the liberal proprietor has erected fifty-two entirely from the ground. Landlords who grudge their tenantry even the repairs requisite to preserve a miserable hovel in safety above their heads, will find everything to censure in this part of the arrangements at *Holkham*; for, not only are these cottages tasteful beyond anything usually erected of the kind, but it is utterly impossible to imagine anything more commodious and replete with convenience. They are, in fact, suitable for the residence of gentlemen of moderate independent fortune. This may be considered superfluous, and certainly less might be made to suffice; but Mr. Coke's farms are all large, and his tenantry must be men of a certain capital. Independently of these considerations, Mr. Coke's is evidently the right system. He does not fail to reflect, when he builds for a tenant, that, in all probability, he has like notions of comfort (though more humble) with himself, and that without certain and ample conveniences he cannot employ the

produce of his farm advantageously to either tenant or landlord. In this spirit Mr. Coke has provided amply for the comfort of his tenantry, not only cultivating and improving their taste while he gratifies his own; but, which is infinitely more important, convincing them at the same time that all the requisites to their comfort and advantage are duly cared for. Though built in a style the most simple, these houses present a whole in accordance with the truest taste, and all has been accomplished by the most simple means. A sea shingle, of which grey is the predominant hue, embedded in plaster, and occasionally divided into compartments, gives a beautiful appearance to the walls; and where coping can be useful or ornamental, it is happily introduced in blocks of what appears beautiful stone, but is, in fact, a naked brick earth, produced on the estate. In this way the neighbourhood has been studded with a number of most tasteful structures, calculated to produce even a moral influence on the conduct of the occupants. Taste, neatness, cleanliness, are thus daily upheld before them, as a pattern set by their landlord; and they are continually silently, but expressively, reminded, that he who has done this for them expects, and has a claim for, a corresponding return. Such is the value of good example, no matter how directed to us; even a well-arranged house, with a cleanly and tasteful exterior, may teach its occupant excellent morality. (*Brit. Farm. Mag.*, vol. viii. p. 12.)

8465. *Mr. Coke's cottages.* "The village of Holkham is occupied, I believe, solely by Mr. Coke's servants and workmen, or by the superannuated members of both classes. The cottages are rendered highly picturesque and neat by the application of shingle, as in the case of the farm-houses; and to each is allotted a garden, sufficient for the occupation of leisure hours, and no more; it being Mr. Coke's opinion, that his labourers would not find their condition ameliorated, nor their capacity to do justice to their employer or themselves extended, were they converted into small farmers or market gardeners." (*Brit. Farm. Mag.*, vol. viii. p. 12.)

8466. *Lady Anne Coke's school* forms a pleasing structure in the village of Holkham, in which the children of the village receive, in the words of the Rev. Henry Berry, "an education suitable to their Christian vocation, and for the rank of life to which God has been pleased to call them." "I am happy," continues the rev. gentleman, "to be able to record the unquestionable utility of this establishment. There is a certain moderate degree of education, which has always been found adequate to raise an industrious and talented man to that consequence in his business, of whatever nature, which such characters are entitled to attain." (p. 14.)

8467.—7862. *Description of a machine for making subterraneous drains in bogs*, the invention of William Kersall Wrigg, C. E., Dublin. This invention may probably be considered impracticable; but we have given it a place on account of its ingenuity, and because it may lead to something better. In fig. 1272., *A A'* are wheels, upon which the frame *B B B* is mounted; the wheels being made of such a breadth upon the sole as to prevent the weight they carry from sinking them in the bog. On the axle of the fore wheels, and revolving with them, is fixed a wheel, *c*, the teeth of which work in those of the bevel-wheel *d*, mounted on the shaft *e*; and upon the same shaft are affixed the bevel-wheels *f* and *g*, and a crank *h*; the shaft *e* revolving in a socket, *a*, fixed to the axle-tree *b*, and a socket, *a'*, fixed to the frame *B*. *I K* are bevel-wheels, working in those marked *r g*; *l* is a knife five or six feet long, according to the depth the drain is made under the surface of the bog, and whose cutting edge, *c*, is made of highly tempered steel, and whose back is an inch thick. *m n* are spindles, say of one inch diameter, revolving with their respective wheels, *i k*, to which they are attached; and at the bottom of these spindles, as at *o* and *p*, are affixed knives, made in the form of oyster-knives, and so placed that the vertical section of their contour shall be a circle, and that each knife be upon a different horizontal plane; so that, in revolving, they shall not move in the same track. This will be understood by referring to the figure: the knife *e*, for instance, is in a different plane to the knife *f*. Other knives may be placed upon the spindles at right angles to the first set, taking care that each blade shall move in a different track from any of the others. The saw *l* is pointed at the bottom to make its entrance into the bog easy; and the spindles *m n* are held in the required position, by the sockets in which they work, as shown in drawing. Let us now suppose the carriage is drawn forward in the direction from *A* to *A'*. As the wheel *A'* turns, the machinery connected with it causes the crank *h* and the wheels *r g* to revolve; the crank giving an alternate motion up and down to the saw, which, being pressed against the fibres of the moss, by being obliged to follow the wheel *A'* at a fixed distance, will cut those fibres, and in its progress divide the bog, so as to leave a passage for the spindles *m n*: but, at the same time the bog is being cut, or sawn through, the spindles *m n* will be revolving at a rapid rate; and as the several knives fixed at their extremities revolve with them, each one presenting its sharp edge to the fibres of the moss, upon a different plane to any other, it is evident that portion of the bog in which the knives revolve, will be divided into a number of minute parts, in proportion to the number of knives used, and the rapidity with which they revolve. We will trace the effect constantly dividing the mossy fibres of the bog will produce. First, for that of the spindle *m*. It will be seen by the drawing, the knives affixed to this spindle are not so close as those at *p*; and for this reason; the fibres of the bog would be cut into minute particles easier by two operations than by one; the action of the knives *p* being much more effective upon the moss previously separated from the large body to which it was attached, than they would before it was so detached; hence the knives at *o* are only designed to cut the fibres so as to separate that portion of the bog where the drain is about to be made, from the large body connected with it.

8468. *The knives at p* are intended to be an inch apart, and as there are four sets, and each knife moves in a different track, the tracks will be but a quarter of an inch asunder, and consequently the matter opposing them will be divided into portions of this length by the action of these knives alone; but the divisions produced by the revolving of the knives at *o*, make the particles still smaller, particularly so, as the spindles *m* and *n* move in opposite directions. This would be the effect if the knives acted upon a body of mere dry twigs; but upon the matter upon which it is intended to operate, the effect would be somewhat different; for the vegetable matter composing bogs is generally found, at a depth of five or six feet, to be in a state of decay, and so easily divided, that, upon being agitated in water, a great portion of it separates into very minute particles, the rest being fine moss, or rotten twigs. It is easy to convert such a substance into a puddle, or semifluid, by mixing it well in water; and as every portion of bog contains a sufficient quantity for this purpose, and the revolution of the knives will divide and mix the bog and water so intimately, as to make a semifluid, having a tendency, like water, to run to

a lower level (but of course by no means so great), the moss, or bog, which has been divided into such minute parts, will be easily carried off to a lower level, if we can get a stream of water to pass over it. It is intended to do so.

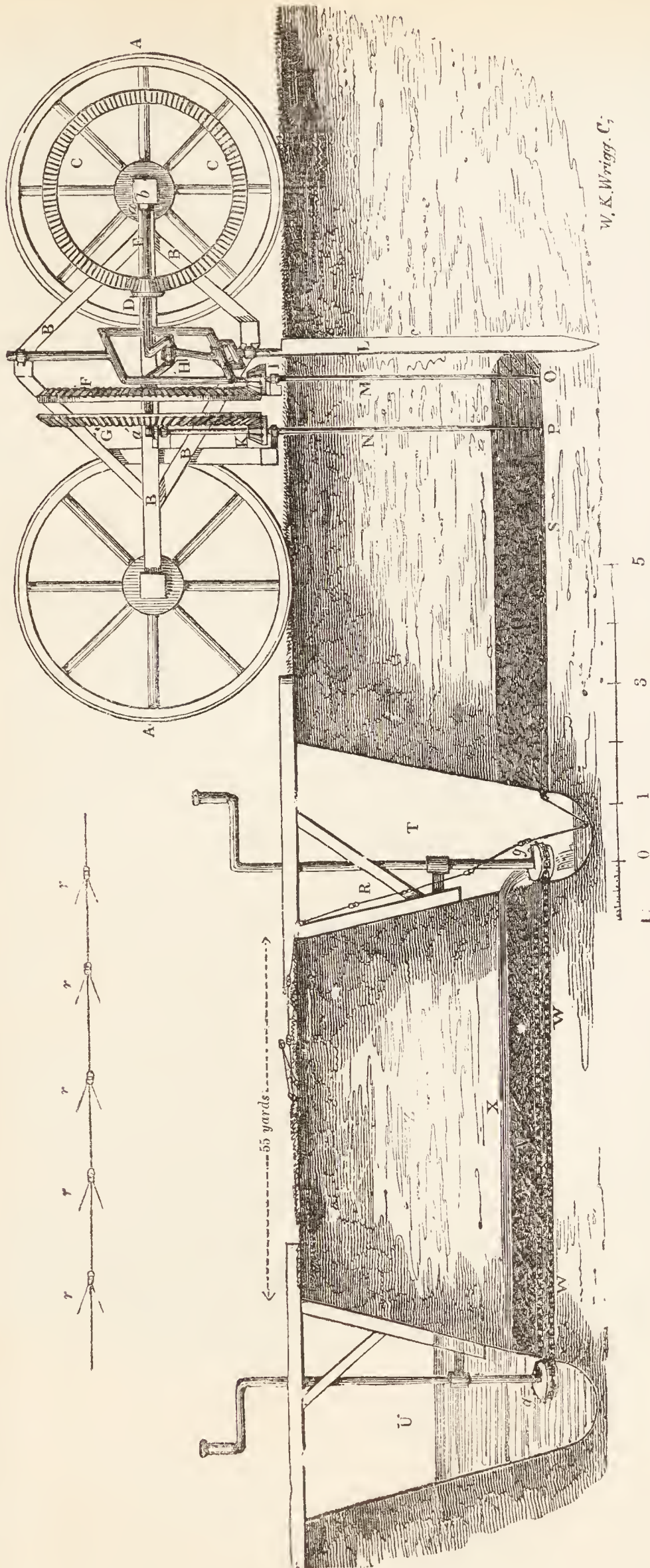
8469. *A chain, r*, made of wire, and in links, in order that it may accommodate itself to the turn out of the main drain *r*, into the minor drain *q*, is attached to the lower part of the spindle *n*, as at *s*, by means of a ring playing upon the spindle, *n*, at perfect ease. Let us suppose the machine has now cut out the minor drain, from one main drain to another, as from *u* to *t*; we shall then have the chain extending through the minor drain *v*, an end being in each of the main drains *u* and *t*. The chain is then detached from the machine, and a fresh chain attached to it, making it ready to proceed with another cross minor drain.

8470. If the puddle made in the minor drain *v* is of a very semifluid nature, it is probable drawing the chain alternately backwards and forwards (which might be done by a labourer at each end) would bring a sufficient quantity of it out into the main drains, to cause an unoccupied space immediately under the undisturbed portion of the bog at *x*; thus making a passage for the water previously dammed up in the drain *v*, to pass over the puddle in the subterraneous drain *v*, and fall into the main drain *t*. As soon as this is effected, the drain may be left to the action of the water, which will very shortly carry away all the puddle out of it into the main drain *t*, from whence it may easily be cleared, without any expense.

8471. But should a *simple wire chain* not bring out the puddle quick enough, then a similar chain, but having fangs attached to it, as shown at *r r r*, fig. 1272., may be used, instead of the one before mentioned. The fangs are to be so arranged, that when they meet resistance moving in one direction, they open a certain distance from the chain, but upon meeting resistance moving in the opposite direction, they lie close to it. It will be unnecessary to describe how this may be accomplished, it will be so easily seen. Its operation in clearing out the puddle will be thus:—Having got it through the drain (and it will offer little more resistance than a plain wire chain, as the fangs will lie close), it is to be moved by men at each end, alternately backwards and forwards: each time it moves backwards, the fangs, from meeting resistance, opening, and bringing before them some portion of the puddle; thus, by a number of such movements, dragging out sufficient puddle to cause an unoccupied space, through which the water will rush.

8472. Or, if the bog is very compact, and the puddle very stiff, such as is likely to be the case in what is known by the name of "black bog," then the following method may be taken, which will give two men sufficient power to drag out the puddle from the subterraneous drain:—Suppose the wire chain *r* (without fangs) to be already dragged through the minor drain. Fastening one end of the chain *w* to the end of the chain *r*, it is drawn through and passed round the rag-wheels *g g*, which rag-wheels are connected with the winches, as shown in the drawing. Now it is evident, if the winches are turned, one portion of the chain will be moving in one direction, while the other portion is moving in the opposite one; and as the chain passes out of the minor drain it brings with it, between the links, and otherwise attached to it, portions of puddle, which fall off in the drain *t*, or are washed off in passing through the water in the drain *u*; the pins, or spikes, on the rag-wheel, as they pass through the several links, forcing off that portion of the stuff held between them. Besides this, that portion of the chain, passing out of the water in the drain *u* into the minor drain *v*, will carry with it a small portion of water, thus assisting the fluidity of the puddle, and consequently decreasing the resistance to the chain passing through. The quantity of stuff brought out of the minor drain by the revolution of the chain, will, after a few turns, cause the puddle in it to sink, and so leave a passage, as by the other methods, immediately under the undisturbed portion of the bog at *x*, for the water to discharge itself; in doing which it will continue to carry along with it portions of the minutely divided matter until the minor drain is cleared out.

8473. Let us now assume that the puddle has been washed out of the minor drain. It will be seen by the distribution of the knives fixed upon the spindles *m n*, the transverse section of the bog divided and puddled by those knives is a perfect circle, and consequently the transverse section of the drain is also a circle, a form best adapted to resist the tendency of the cir-



W. K. Wrigg. C;

cumambient bog to collapse; but although the bog immediately surrounding the drain has not been changed in its consistency by any operation of the machine, yet, containing so much water as it does, it necessarily partakes in some degree of the nature of fluids; hence we find the bottom of drains made in wet spongy "red bogs," have as strong a tendency to rise at the bottom, as the sides have to approach each other. Partaking, then, as the great mass of the bog surrounding the minor drain does, of a fluid nature, it will have a tendency to fill up the space made by extracting the puddle, but, in doing so, it will slowly approach. Now, as the pressure upon the bottom, sides, and top, in fact, upon every part of the circle surrounding the vacant space, is equal, or nearly so, the surrounding matter will approach the centre of the vacant space with equal velocity; and as it approaches, the circle being narrowed, the mossy fibres composing the bog immediately adjoining it will be pressed nearer to each other; and thus, being forced to part with a considerable quantity of the water which kept them apart, will gradually acquire a greater compactness and resistance, as the circle narrows, until, in the end, the fibrous matter will be pressed so close as to resist the pressure of the surrounding bog forcing it into a smaller space. We shall thus have formed a tubular drain, though something less in its dimensions than the diameter of the circle made by the knives o p. I never yet saw sufficient water coming from a minor drain to fill a two-inch bore, and I have seen a great deal of bog draining, and paid much attention to it. Even when any considerable quantity is discharged, it is to be supposed not from the drainage of the bog immediately about it, but from its having crossed the course of some spring. I may remark here (though the remark is unconnected with the effects produced by this draining-machine), that, when this is suspected, means should be taken to discharge the waters of the spring as quickly as possible, if it is a bog spring; but, if a spring supplied from the upland, the water should be impounded for irrigation. In general, both these objects may be obtained with little trouble or expense.

8474. *Minor drains* should not only be sufficiently large to pass off the water from the bog immediately surrounding them, but also to prevent them from being easily choked. I think they ought not to be less than six inches in diameter, and by way of securing them this size, the diameter of the circle made by knives might be ten inches, thus allowing them four inches for collapsing. The bog immediately surrounding the drain would have to be pressed into three fifths of its original bulk, before it enclosed the drain so as to reduce it to six inches in diameter; but, before it was pressed into so much less space than it originally occupied, it would have acquired a compactness enabling it to resist the pressure behind it, and the drains would, in general, be more than six inches in diameter. According to the consistency of the bog, the diameter of the circle made by the knives might be regulated.

8475. *Mode of using the machine.* Having described the operation of the machine, it will be necessary to point out the methods of overcoming any obstructions that may pre-

sent themselves upon putting it in motion. We will, in the first instance, consider horses to be used for this purpose; in which case it will be necessary that the main drains, such as T and U, be made some time before the minor drains are commenced; in order that the bog z, lying between them, may be sufficiently consolidated to admit of horses, with proper pattens, working upon it. This will take place upon the edges of bogs in a short time after the main drains are opened; but in the interior the consolidation will take place slowly, for, from its very spongy quality, it will not part with its water so quickly as the denser bog on the edges. It is the general practice to make the main drains parallel to each other, and at a distance of about ten statute perches asunder; and yet, although so near, so strongly retentive is bog of water, that, in very soft spongy bogs, it would require at least two or three years to drain them sufficiently, by this means, to admit of horses working upon them. Upon the edges they would be sufficiently firm in a few months. The bog may always be rendered sufficiently dry by taking a large quantity in hand at once, so that, before the last of the main draining is finished, the banks between the first drains cut will be well consolidated; or, if a small quantity only is taken in hand, by waiting till it does consolidate.

8476. *The probable expense of working the machine* by horses will be first calculated, and afterwards a method shown by which the minor drains may be made without waiting for the main drains to draw off any considerable quantity of water from the bog; thus expediting its reclamation, without adding to the expense.

8477. *The weight of the carriage and its machinery* is about one ton, and, as the wheels are intended to be nine inches upon the sole, they will sink little under so small a weight. Two horses would move the carriage with ease, and from two to four more (according to the depth and size of the drains, for they must vary with the nature of the bog) would overcome the resistance of the saw and spindles M N, with their knives. If we say five horses on an average, we shall be perfectly safe. I believe a less number would do. To this must be added two men for driving. The draining-machine is to proceed in a straight line, passing over the main drains, from one division of bog to another, until a minor drain is made from one extreme of the bog under reclamation to the other extreme.

8478. *In cutting main drains* it is usual to make them open, but I should propose, that occasionally bog bridges be left, say at a distance of every eleven yards; that is, leaving an open drain for eight yards, and having a bog bridge three yards broad. Many advantages attend this plan, not appertaining to the usual method. In the first instance, the labour and expense is something less; they afford an easy passage for men or cattle to walk over; thus preventing, in a great measure, the injury done in leaping across, and so destroying the sides of the drain, and choking it with the bog stuff thrown into it by these means. Bog bridges, if placed at short distances, prevent the collapse of the drains, and would on this account, enable us to cut them at once sufficiently deep, without waiting, as is necessary now, for two or three years. Viewed in connection with this draining-machine, they would afford a ready passage for the horses, and so save labour and expense, and facilitate the operation.

8479. *The method of passing the horses and machine over the main drains.* As soon as the horses arrive at the edge of a main drain, the chains by which they are drawing the carriage may be lengthened, so as to allow them to turn out of the direction they were proceeding in, and pass over a bog bridge, which will always be within two yards of the line of a minor drain; supposing them to be a statute perch distant from each other, as is usual. There will be little inconvenience, or loss of time, in this. As soon as they are on the other side they may again be hooked to the carriage, giving them chain sufficient to reach over the drain; a pass for the carriage-wheels having been previously formed. The pass is to be made thus:—Suppose the main drain to be four feet six inches wide at the top. Two three-inch planks are to be provided, each one foot broad and eight feet long, and having ribs of iron fastened on each edge of each of the planks, to prevent the wheels of the carriage from slipping off in passing over the drain. The length of these planks will give a bearing of one foot nine inches on each side of the drain, which will be quite enough, as there can only be a pressure of five hundred-weight on a plank at one time. Their extremes are to be worked off to a chisel edge, in order to facilitate the carriage mounting upon them. The planks being placed over the drain before the machine comes up, there will be no delay, except taking the horses to the other side of the drain, and unhooking them from the carriage and hooking them to again. As soon as the machine has passed over the drain, two men are each to take up a plank (they will not be a hundred weight each) and proceed to the next main drain and make a pass. They may easily have this done by the time the carriage comes up, there being little more trouble than throwing down the planks, of course due care being taken to place them in the line of direction in which the carriage is to move. In passing over drains already made, that have no bog bridges, it will be necessary to connect with the carriage pass more planks, so as to allow the horses to walk over without difficulty: this may easily be done.

8480. *The number of men* required to clean out a sufficiency of the puddle from the minor drains, so as to give vent to the water through them, is the next consideration. Except in very compact "black bog," it will not be required to use the winches with the chain and rag-wheel; and as bog of this description bears but a small proportion to the spongy or "red bog," this method will seldom need be resorted to. However, to make sure, the calculation of the expense is made upon the assump-

tion that it will always be necessary. The platforms used for working the chain and rag-wheel, together with their machinery, do not weigh two cwt. each; so that two men would be able to carry one at a time, from drain to drain, as they were required. Let it be observed, it will not be necessary to move both platforms when a fresh drain is to be cleared by them. Thus, if the drain the machine is forming is to be cleared after the one in which the chain is working, the platform over the drain T would not have to be removed; it would merely have to be turned round: but the platform over U would have to be carried double the distance of U T. Calculating the men would be twice the time in carrying it this distance that the draining-machine is in moving from drain to drain, and that two men, having got the chain through the drain, would be about the same time in working out the necessary quantity of puddle from a minor drain as the draining-machine is in puddling one; and that it would take them twice this time to insert the chain, and draw it out again; we have two men occupied five times as long in cleaning a drain as is taken to puddle one; consequently it would, upon this calculation, take ten men to clean out the drains as fast as they were puddled. We will allow twelve men for this portion of the business. It must not be forgotten, we are assuming *all* the drains will have to be thus cleared, although it is by no means probable. We shall be under the mark, if it is only calculated the horses would move the draining-machine at the rate of one mile per hour; however, we will make our calculation on this assumption. If the horses work eight hours a day, they will make eight miles of draining. We shall have the day's expenses then as under, calculating them from the highest rate of labour in Ireland, a country to which this machine is particularly applicable.

	L.	s.	d.
5 horses, at 2s. per day	-	-	0 10 0
2 men, making passes, at 1s.	-	-	0 2 0
2 men, driving, at 1s.	-	-	0 2 0
12 men, cleaning out drains, at 1s.	-	-	0 12 0
Wear and tear of machine, and pattens of horses, say	-	-	0 2 0

Cost of making eight miles of minor drains - 1 8 0

Now there would require 160 perches of minor drains per acre, supposing them to be made a perch asunder, the cost of which would only be 1s. 9d. The present expense is about 14s. per statute acre for the same work.

8481. *The main drains cost now, on an average, about 9s. per statute acre, making the whole expense 23s.* By the use of this machine the expense of main drains and minor drains would be 10s. 9d.; thus at once doubling the profits of bog reclamation, so far as draining is concerned.

8482. *Objections answered.* It may be said, horses could not work upon a very wet bog till a long time after the main drains had been made; perhaps years. To meet this objection, among many other obvious means, a windlass, mounted on a moveable platform, might be used; the windlass to be placed over the main drain, next the front of the draining-machine; and the platform upon which it is mounted to be made so that it shall have a bearing against the side of the drain, sufficient to enable it to resist the reaction from the draught of the machine. Its form will be similar to the platform used for clearing out the puddle; but, perhaps, it will be necessary to offer a greater face of planking to the side of the drain. Its weight need not exceed from three to four cwt., so that it may be easily removed, as occasion requires. By attaching a rope from the windlass to the carriage, it of course can be dragged on; and the expense by this method will probably be about the same as when horses are used. If it is objected, that drains made at one operation, in such wet bogs as we now are speaking of, will soon close; it may be answered, that though the collapse will undoubtedly be great, yet, being something like equal on all parts, the circular form of the drain will most certainly prevent a perfect closure of the aperture. This, though true of arched drains, is not so of the shoulder drains now in use: for, while the former increase their resistance to the pressure surrounding them, the nearer the approach to the centre of the unoccupied space, the latter, whose sides are straight lines, decrease in their power of resistance, under the same circumstances: hence it is found totally impossible to make shoulder drains to stand, except in tolerably firm bog; and, to secure this, they are generally made in three operations. I by no means admit it; but we will suppose every drain was to close after a short time: before doing so, they most certainly would have discharged a great portion of the water from the bog, and have consolidated it considerably, so that there would be no grounds to fear the closure of a second set of minor drains made after the first set had drawn off the great body of water from the bog. Should even this be necessary, the expense of the minor drain would only amount to 3s. 6d. per statute acre. It will readily be admitted, that, where there is the slightest fear of a circular drain closing, a straight-sided drain could not possibly stand.

8483. *The profits of reclaiming bogs.* By the use of such a machine as is here described, the profits of bog reclamation would be much increased; but, as in conjunction with other machines the inventor of this has contrived one for carrying earth on bogs cheaper than by movable railroads now in use, and performing other operations in bog improvements (which he will take another opportunity to describe), there can be little doubt that bogs may be converted into land not inferior to some of the best upland, and that, too, so as to yield a profit of from 10 to 40 per cent, according to the particular circumstances under which the bog lies; thus not only yielding a handsome income to the reclaimers, but also as providing a large field for the employment of the labouring population.

THE END.

LONDON:

Printed by A. SPOTTISWOODE,
New-Street-Square.





